

# Lang

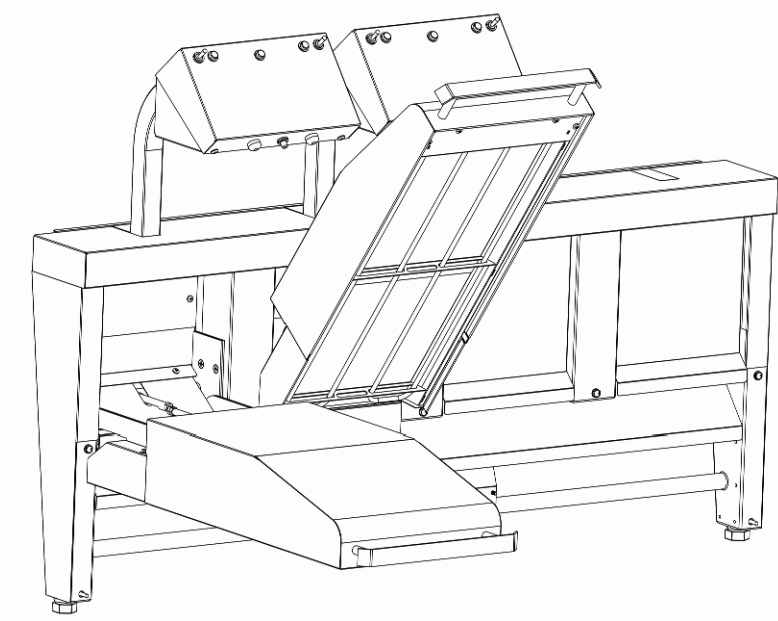

## Installation, Operation, Maintenance, & Troubleshooting Model: XLH12, Electric Clamshell®

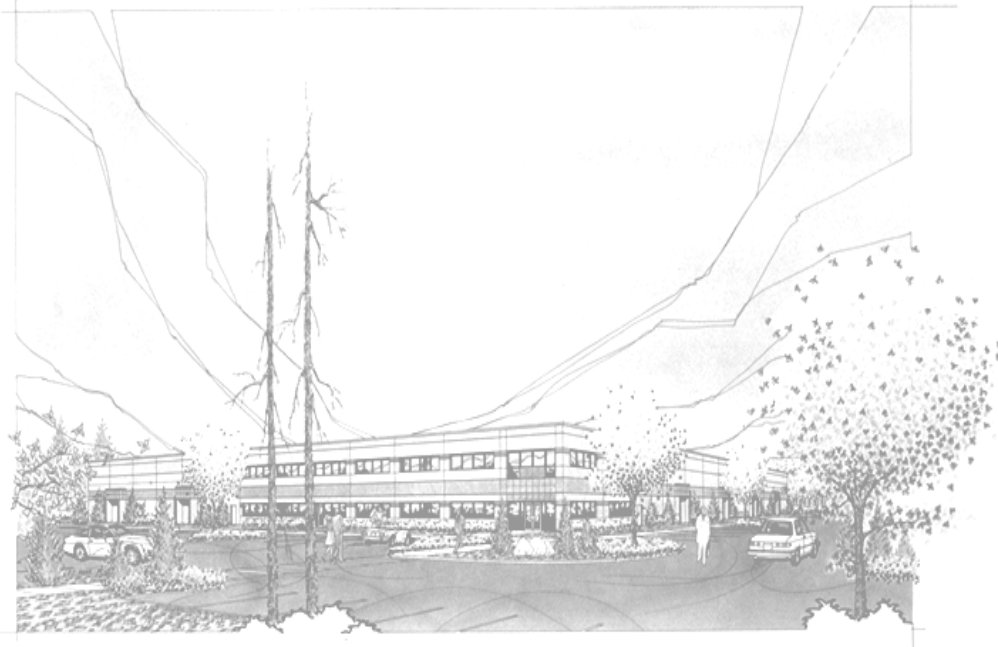

THE INFORMATION IN THIS MANUAL IS CRUCIAL AND MUST BE RETAINED FOR FUTURE REFERENCE. READ, UNDERSTAND AND FOLLOW THE INSTRUCTIONS AND WARNINGS CONTAINED IN THIS MANUAL.

**DANGER** POTENTIALLY HAZARDOUS SITUATION WHICH, IF NOT AVOIDED, COULD RESULT IN DEATH.



**WARNING** POTENTIALLY HAZARDOUS SITUATION WHICH, IF NOT AVOIDED, COULD RESULT IN DEATH OR SERIOUS INJURY.



**CAUTION** POTENTIALLY HAZARDOUS SITUATION WHICH, IF NOT AVOIDED, MAY RESULT IN MINOR OR MODERATE INJURY.



**NOTICE** Helpful operation and installation instructions and tips are present.



**FOR YOUR SAFETY**















**DO NOT STORE OR USE GASOLINE OR OTHER FLAMMABLE VAPORS AND LIQUIDS IN THE VICINITY OF THIS OR ANY OTHER APPLIANCE.**

**WARNING: IMPROPER INSTALLATION, ADJUSTMENT, ALTERATION, SERVICE OR MAINTENANCE CAN CAUSE PROPERTY DAMAGE, INJURY OR DEATH. READ THE INSTALLATION, OPERATING AND MAINTENANCE INSTRUCTIONS THOROUGHLY BEFORE INSTALLING OR SERVICING THIS EQUIPMENT.**

|                          |                           |
|--------------------------|---------------------------|
| <b>Model #:</b>          | <b>Purchased From:</b>    |
| <b>Serial #:</b>         | <b>Location:</b>          |
| <b>Date Purchased:</b>   | <b>Date Installed:</b>    |
| <b>Purchase Order #:</b> | <b>For Service, Call:</b> |

# TABLE OF CONTENTS

| <b>CHAPTER</b>                      | <b>PAGE</b> |
|-------------------------------------|-------------|
| TABLE OF CONTENTS .....             | 3           |
| READ FIRST .....                    | 4-5         |
| SAFETY PROCEDURES .....             | 6           |
| EQUIPMENT DESCRIPTION .....         | 7           |
| UNPACKING.....                      | 8           |
| INSTALLATION .....                  | 9           |
| INITIAL START UP AND OPERATION..... | 10          |
| MAINTENANCE & CLEANING.....         | 11          |
| TROUBLE SHOOTING .....              | 12          |
| ILLUSTRATED PARTS BREAKDOWN .....   | 13          |
| PARTS LIST .....                    | 14          |
| WIRING DIAGRAM .....                | 15          |

|                       |   |   |
|-----------------------|---|---|
| <b><u>CAUTION</u></b> | THE UNIT IS EXTREMELY HEAVY. FOR SAFE HANDLING, INSTALLER SHOULD OBTAIN HELP AS NEEDED, OR EMPLOY APPROPRIATE MATERIALS HANDLING EQUIPMENT (SUCH AS A FORKLIFT, DOLLY, OR PALLET JACK) TO REMOVE THE UNIT FROM THE SKID AND MOVE IT TO THE PLACE OF INSTALLATION.           |    |
| <b><u>CAUTION</u></b> | ANY STAND, COUNTER OR OTHER DEVICE ON WHICH UNIT WILL BE LOCATED MUST BE DESIGNED TO SUPPORT THE WEIGHT OF THE UNIT.  |    |
| <b><u>CAUTION</u></b> | SHIPPING STRAPS ARE UNDER TENSION AND CAN SNAP BACK WHEN CUT.   |    |
| <b><u>DANGER</u></b>  | THIS APPLIANCE MUST BE GROUNDED AT THE TERMINAL PROVIDED. FAILURE TO GROUND THE APPLIANCE COULD RESULT IN ELECTROCUTION AND DEATH.  |    |
| <b><u>WARNING</u></b> | INSTALLATION OF THE UNIT MUST BE DONE BY PERSONNEL QUALIFIED TO WORK WITH ELECTRICITY AND PLUMBING. IMPROPER INSTALLATION CAN CAUSE INJURY TO PERSONNEL AND/OR DAMAGE TO EQUIPMENT. UNIT MUST BE INSTALLED IN ACCORDANCE WITH ALL APPLICABLE CODES.                         |    |
| <b><u>WARNING</u></b> | BROILER ELEMENTS CAN IGNITE GREASE FIRES ON THE GRIDDLE SURFACE WHICH MAY RESULT IN PROPERTY DAMAGE, SERIOUS INJURY OR DEATH. ENSURE GRIDDLE SURFACE IS SLOPPED DOWN FROM BACK TO FRONT BY AT LEAST 1/4" BEFORE COOKING   |    |
| <b><u>NOTICE</u></b>  | The data plate is located behind hood wrap on hood frame. The hood voltage, wattage, serial number, wire size, and clearance specifications are on the data plate. This information should be carefully read and understood before proceeding with the installation.        |  |
| <b><u>NOTICE</u></b>  | The installation of any components such as a vent hood, grease extractors, fire extinguisher systems, must conform to their applicable National, State and locally recognized installation standards.   |  |
| <b><u>NOTICE</u></b>  | During the first few hours of operation you may notice a small amount of smoke coming from the unit, and a faint odor from the smoke. This is normal for a new unit and will disappear after the first few hours of use.  |  |
| <b><u>CAUTION</u></b> | ALWAYS KEEP THE AREA NEAR THE APPLIANCE FREE FROM COMBUSTIBLE MATERIALS.  |  |
| <b><u>CAUTION</u></b> | KEEP FLOOR IN FRONT OF EQUIPMENT CLEAN AND DRY. IF SPILLS OCCUR, CLEAN IMMEDIATELY, TO AVOID THE DANGER OF SLIPS OR FALLS.  |  |
| <b><u>WARNING</u></b> | KEEP WATER AND SOLUTIONS OUT OF CONTROLS. NEVER SPRAY OR HOSE CONTROL CONSOLE, ELECTRICAL CONNECTIONS, ETC.   |  |
| <b><u>CAUTION</u></b> | MOST CLEANERS ARE HARMFUL TO THE SKIN, EYES, MUCOUS MEMBRANES AND CLOTHING. PRECAUTIONS SHOULD BE TAKEN TO WEAR RUBBER GLOVES, GOGGLES OR FACE SHIELD AND PROTECTIVE CLOTHING. CAREFULLY READ THE WARNING AND FOLLOW THE DIRECTIONS ON THE LABEL OF THE CLEANER TO BE USED. |  |
| <b><u>NOTICE</u></b>  | The plunger switch plunger should be compressed approximately 1/8" with the hood in the up position.  |  |

**NOTICE**

Service on this, or any other, LANG appliance must be performed by qualified personnel only. Consult your authorized service station directory or call the factory at 1-800-224-LANG (5264), or [WWW.LANGWORLD.COM](http://WWW.LANGWORLD.COM) For the service station nearest you.



**WARNING**

**HIGH VOLTAGES ARE PRESENT INSIDE THIS APPLIANCE WHEN THE UNIT IS PLUGGED/WIRED INTO A LIVE RECEPTACLE. BEFORE REPLACING ANY PARTS, DISCONNECT THE UNIT FROM THE ELECTRIC POWER SUPPLY.**



**CAUTION**

**USE OF ANY REPLACEMENT PARTS OTHER THAN THOSE SUPPLIED BY LANG OR THEIR AUTHORIZED DISTRIBUTORS CAN CAUSE BODILY INJURY TO THE OPERATOR AND DAMAGE TO THE EQUIPMENT AND WILL VOID ALL WARRANTIES.**



## **Lockout Procedure**

1. Announce lockout to other personnel.
2. Turn power off at main panel.
3. Test lockout by turning power switch on and observing if elements come on. Check heater circuit with voltmeter.
4. Perform necessary repairs or tests.
5. Clear unit of personnel before restarting.
6. Turn power on at main panel.
7. Announce unit is “ON” to other personnel.

## **Safety Precautions**

The Manufacturer, Lang Manufacturing, hereby disclaims any and all responsibility for injury, damage, loss or other claim that may occur to person or property from improper alteration, modification, addition, operation, maintenance or service, whether it be mechanical, electrical, or otherwise, which may occur from such improper alteration, modification, addition, operation, maintenance or service to this piece of equipment.

## **Safety Considerations**

Your Lang 12-inch Clamshell® is manufactured to rigid standards. This equipment is ETL, CETL, or NSF listed meeting safety and sanitation standards.

The presence of safety equipment control and interlocks on an appliance and attendant components of installation cannot in and of themselves, assure absolute safety of operation. Diligent, capable, well trained operators and maintenance personnel, as well as proper programs of operation and maintenance, are essential to the safe and reliable operation of this appliance.

- A. The **responsibility of the manufacturer** is to supply suitable, comprehensive instructions and recommendations for the operation and maintenance of the appliance.
- B. Trained qualified and factory-authorized personnel must perform all operation, maintenance and repair of these appliances. It is the **responsibility of the owner / operator** to ensure that this happens.
- C. A regular periodic program of cleaning, inspection and maintenance must be established and comprehensive maintenance records maintained. It is the **sole responsibility of the user** to establish, schedule and enforce the frequency and scope of these programs in keeping with recommended practice and with due consideration given to actual operating conditions.
- D. The appliance must be operated within the limits it was designed for, which will not exceed the working limits of any component within the appliance as a whole.

## EQUIPMENT DESCRIPTION

### **Lang Model: XLH12** **12-Inch Electric Clamshell®**

#### **Controls**

The XLH12 Broiler has a power switch located on the right of the pylon mounted control panel. A white indicator light adjacent to the power switch indicates power when power is on. A plunger switch mounted at the center of the control panel, actuated by placing the hood in the up “idle” position, switches between full and idle power settings. A green indicator light indicates when full “cooking” power is set. A standby circuit, consisting of a momentary contact switch and an amber indicator light, allows element power to be reduced to idle when the hood is in the down “cooking” position.

#### **Technical**

The broiler, not including the griddle, is standard 208 or 240-volt, single phase. The voltage must be specified when ordering.

## Receiving the Unit



Upon receipt, check for freight damage, both visible and concealed. Visible damage should be noted on the freight bill at the time of delivery and signed by the carrier's agent. Concealed loss or damage means loss or damage, which does not become apparent until the merchandise has been unpacked. If concealed loss or damage is discovered upon unpacking, make a written request for inspection by the carrier's agent within 15 days of delivery. All packing material should be kept for inspection. Do not return damaged merchandise to Lang Manufacturing Company. File your claim with the carrier.

## Location

Prior to un-crating, move the unit as near its intended location as practical. The crating will help protect the unit from the physical damage normally associated with moving it through hallways and doorways.

## Un-crating

The unit will arrive completely assembled inside a wood frame covered by cardboard box and strapped to a skid. **Remove the cardboard cover, cut the straps and remove the wood frame.**

|                       |  |   |
|-----------------------|--|---|
| <b><u>CAUTION</u></b> | <b>THE UNIT IS EXTREMELY HEAVY. FOR SAFE HANDLING, INSTALLER SHOULD OBTAIN HELP AS NEEDED, OR EMPLOY APPROPRIATE MATERIALS HANDLING EQUIPMENT (SUCH AS A FORKLIFT, DOLLY, OR PALLET JACK) TO REMOVE THE UNIT FROM THE SKID AND MOVE IT TO THE PLACE OF INSTALLATION.</b> |    |
| <b><u>CAUTION</u></b> | <b>ANY STAND, COUNTER OR OTHER DEVICE ON WHICH THE UNIT WILL BE LOCATED MUST BE DESIGNED TO SUPPORT THE WEIGHT OF THE UNIT.</b>  |  |
| <b><u>CAUTION</u></b> | <b>SHIPPING STRAPS ARE UNDER TENSION AND CAN SNAP BACK WHEN CUT.</b>   |  |

The unit may now be removed from the skid.



# INSTALLATION

**DANGER** THIS APPLIANCE MUST BE GROUNDED AT THE TERMINAL PROVIDED. FAILURE TO GROUND THE APPLIANCE COULD RESULT IN ELECTROCUTION AND DEATH.

**WARNING** INSTALLATION OF THE UNIT MUST BE DONE BY PERSONNEL QUALIFIED TO WORK WITH ELECTRICITY AND PLUMBING. IMPROPER INSTALLATION CAN CAUSE INJURY TO PERSONNEL AND/OR DAMAGE TO EQUIPMENT. UNIT MUST BE INSTALLED IN ACCORDANCE WITH ALL APPLICABLE CODES.

**WARNING** BROILER ELEMENTS CAN IGNITE GREASE FIRES ON THE GRIDDLE SURFACE WHICH MAY RESULT IN PROPERTY DAMAGE, SERIOUS INJURY OR DEATH. ENSURE GRIDDLE SURFACE IS SLOPPED DOWN FROM BACK TO FRONT BY AT LEAST ¼” BEFORE COOKING

**NOTICE** The data plate is located behind hood wrap on hood frame. The unit voltage, wattage, serial number, wire size, and clearance specifications are on the data plate. This information should be carefully read and understood before proceeding with the installation.

**NOTICE** The installation of any components such as a vent hood, grease extractors, fire extinguisher systems, must conform to their applicable National, State and locally recognized installation standards.



## **ELECTRICAL CONNECTION**

Ensure griddle is installed per griddle installation instructions.

If installation is a retrofit, locate and drill mounting holes in griddle splasher. Mount hood with hardware provided.

Electrical service connection is made in the box mounted at the back of the griddle.

| MODEL:<br>XLH12 | VOLTS | KW PER PHASE |       |       |       | AMPS PER LINE THREE PHASE |     |     | SINGLE PHASE |
|-----------------|-------|--------------|-------|-------|-------|---------------------------|-----|-----|--------------|
|                 |       | L1-L2        | L2-L3 | L1-L3 | TOTAL | L1                        | L2  | L3  |              |
| 1 EA.           | 208V  | 3.8          |       |       | 3.8   | N/A                       | N/A | N/A | 18.3         |
| 1 EA.           | 240V  | 3.8          |       |       | 3.8   | N/A                       | N/A | N/A | 15.8         |
| 2 EA.           | 208V  | 3.8          | 3.8   |       | 7.6   | N/A                       | N/A | N/A | 36.5         |
| 2 EA.           | 240V  | 3.8          | 3.8   |       | 7.6   | N/A                       | N/A | N/A | 31.7         |

## **CLEARANCES**

Maintain clearances of base appliance. For use only in non-combustible locations.

## INITIAL START UP

### **NOTICE**

**During the first few hours of operation you may notice a small amount of smoke coming from the appliance, and a faint odor from the smoke. This is normal for a new oven and will disappear after the first few hours of use.**



Each unit is preheated, tested and calibrated at the factory before shipment. However, due to temperature and climate changes during shipment the unit can absorb moisture and should be dried out before attempting to put it in full operation.

Prior to putting any unit into full time operation at normal cooking temperatures, it must be thoroughly "seasoned" or dried out. Moisture absorption in the closed spaces, in the insulation and even inside the heating elements can cause future trouble if not properly treated.

Before the initial use of the unit, the element must be thoroughly allowed to dry out. This can be done by cycling the unit on and placing the hood into the down position. Allow the unit to saturate until all vapor and condensation has been eliminated. For best operating results allow the unit to thoroughly dry out for 8 to 12 hours.

If the unit is out of use for three or more days, a one-hour preheat schedule should be used, especially when exposed to high humidity and/or cool temperatures.

## OPERATION

### **CAUTION**

**ALWAYS KEEP THE AREA NEAR THE APPLIANCE FREE FROM COMBUSTIBLE MATERIALS.**



### **CAUTION**

**KEEP FLOOR IN FRONT OF EQUIPMENT CLEAN AND DRY. IF SPILLS OCCUR, CLEAN IMMEDIATELY, TO AVOID THE DANGER OF SLIPS OR FALLS.**



### **GENERAL**

Once the griddle has been loaded properly lower the hood over the product.

Elements must not touch product when clamshell is in the closed position.

## MAINTENANCE & CLEANING

### **WARNING**

**KEEP WATER AND SOLUTIONS OUT OF CONTROLS. NEVER SPRAY OR HOSE CONTROL CONSOLE, ELECTRICAL CONNECTIONS, ETC.**



### **CAUTION**

**MOST CLEANERS ARE HARMFUL TO THE SKIN, EYES, MUCOUS MEMBRANES AND CLOTHING. PRECAUTIONS SHOULD BE TAKEN TO WEAR RUBBER GLOVES, GOGGLES OR FACE SHIELD AND PROTECTIVE CLOTHING. CAREFULLY READ THE WARNING AND FOLLOW THE DIRECTIONS ON THE LABEL OF THE CLEANER TO BE USED.**



### **DAILY CLEANING**

The XLH12 hood is a self-cleaning device. When the hood is in the down position it will bake off any debris that may accumulate during normal business operation.

*Do not use any water or cleaning solution on the elements.*

Clean the exterior of the appliance with Lang Mfg. Prima Shine (72804-41) to maintain a gleaming appearance.

Wipe drip shield between hood and griddle to remove any grease.

### **WEEKLY CLEANING**

It may be necessary after high use to allow the hood to burn off any carbon build up.

With a cold griddle, lower the hood and allow the hood to cook for 30 minutes.

Additional time may be necessary for more baked-on grease.

## Symptoms

What follows is a chart of Symptoms, Possible Causes, and Remedy's to aid in diagnosing faults with the oven.

Refer to the Symptoms column to locate the type of failure then to the Possible Cause for the items to be checked. On the following pages is a chart with the possible causes and the test to properly identify the problem.

| SYMPTOM               | POSSIBLE CAUSE  |
|-----------------------|---|
| Unit will not heat    | <ul style="list-style-type: none"> <li>• No power to Unit</li> <li>• Defective power switch</li> <li>• Defective micro switch</li> <li>• Defective element</li> </ul> |
| Unit will not stay up | <ul style="list-style-type: none"> <li>• Spring needs to be adjusted</li> <li>• Spring needs to be replaced</li> </ul>  |

### **NOTICE**

**Service on this, or any other, LANG appliance must be performed by qualified personnel only. Consult your authorized service station directory or call the factory at 1-800-224-LANG (5264), or WWW.LANGWORLD.COM For the service station nearest you.**



### **WARNING**

**BOTH HIGH AND LOW VOLTAGES ARE PRESENT INSIDE THIS APPLIANCE WHEN THE UNIT IS PLUGGED/WIRED INTO A LIVE RECEPTACLE. BEFORE REPLACING ANY PARTS, DISCONNECT THE UNIT FROM THE ELECTRIC POWER SUPPLY.**



### **CAUTION**

**USE OF ANY REPLACEMENT PARTS OTHER THAN THOSE SUPPLIED BY LANG OR THEIR AUTHORIZED DISTRIBUTORS CAN CAUSE BODILY INJURY TO THE OPERATOR AND DAMAGE TO THE EQUIPMENT AND WILL VOID ALL WARRANTIES.**



## TESTS

| Possible Cause           | TEST  |
|--------------------------|---|
| No Power to unit         | <ul style="list-style-type: none"> <li>• Confirm that circuit breakers are on.</li> <li>• Check for voltage at the terminal block. *</li> </ul> |
| Defective power switch   | <ul style="list-style-type: none"> <li>• Check toggle switch for normal operation.</li> </ul>   |
| Defective plunger switch | <ul style="list-style-type: none"> <li>• Check plunger switch for normal operation</li> </ul>   |
| Failed element           | <ul style="list-style-type: none"> <li>• Remove the wires and check for continuity across the element*</li> </ul>                               |

\* A factory authorized service representative should perform this work.

# ILLUSTRATED PARTS BREAKDOWN

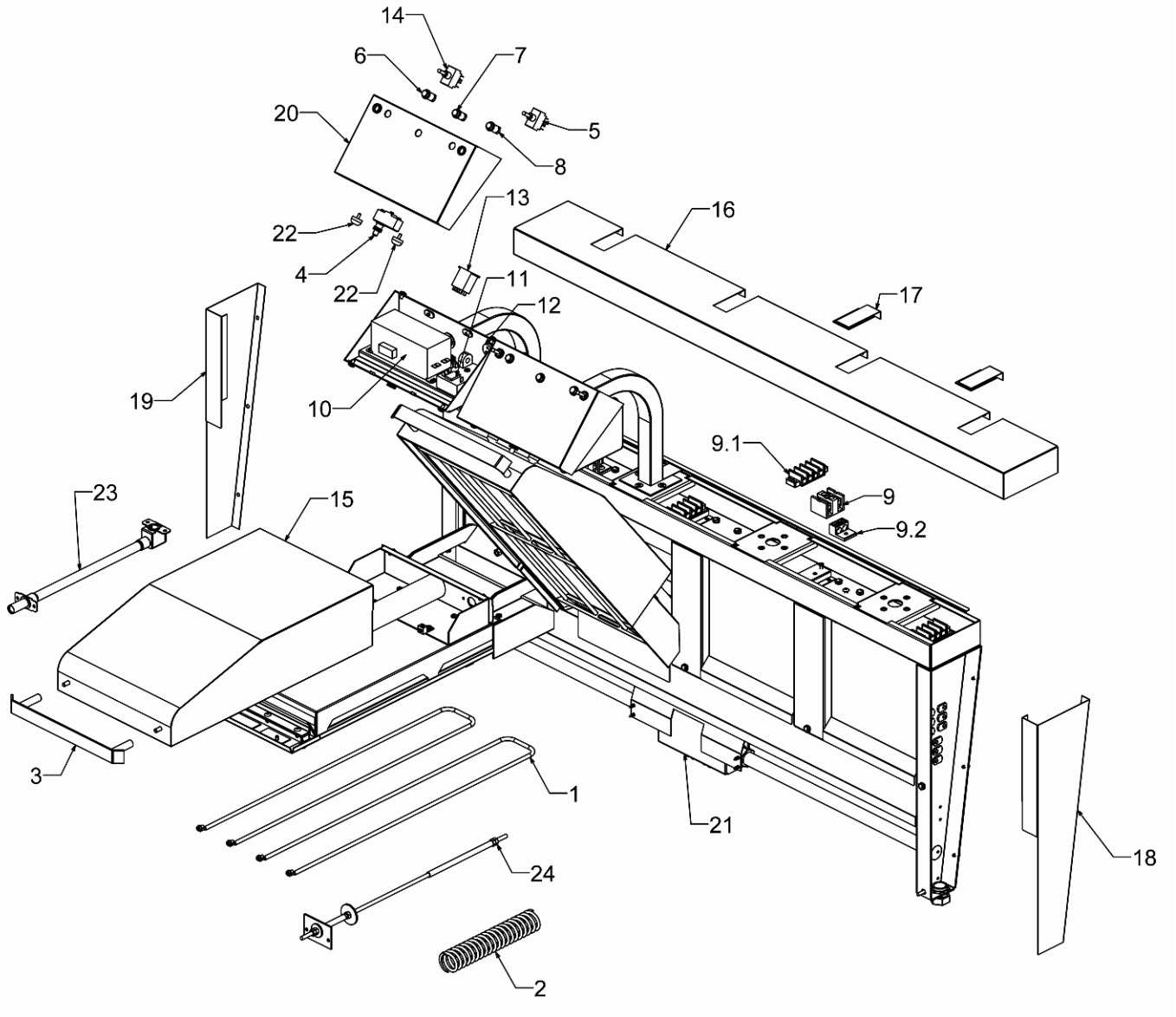

(Shown: 4ft Electric with Two 12-Inch Clamshell's)

**XLH12H**

**ELECTRIC 12-INCH CLAMSHELL**

| <b>ITEM</b> | <b>DESCRIPTION</b>                              | <b>PART NO.</b> |
|-------------|---|-----------------|
| 1           | Element, 208 Volt                               | 11160-32        |
| 1A          | Element, 240 Volt                               | 11160-33        |
| 2           | Spring, Hood                                    | 51002-15        |
| 3           | Handle Assembly                                 | XLH-709         |
| 4           | Micro Switch, Plunger                           | 30301-11        |
| 5           | Toggle Switch, DPDT                             | 30303-06        |
| 6           | Indicator Lamp (Amber)                          | 31601-15        |
| 7           | Indicator Lamp (Green)                          | 31601-16        |
| 8           | Indicator Lamp (White)                          | 31601-17        |
| 9           | Terminal Block, 2 Pole                          | 30500-08        |
| 9.1         | Terminal Strip, 4 Pole                          | 30500-02        |
| 9.2         | Grounding Lug, 2 Hole                           | 31200-08        |
| 10          | Interlocking Contactor                          | 30705-01        |
| 11          | Current Sensor                                  | 41100-31        |
| 12          | Timer Plug                                      | 40302-02        |
| 13          | Relay, 240V, DPDT                               | 30600-10        |
| 14          | Momentary Switch                                | 30303-16        |
| 15          | Hood Wrap                                       | XLH-609         |
| 16          | Bridge Cover-4ft. (Shown)                       | XLH-636-4       |
| 16A         | Bridge Cover-2ft.                               | XLH-636-2       |
| 16B         | Bridge Cover-3ft.                               | XLH-636-3       |
| 16C         | Bridge Cover-5ft.                               | XLH-636-5       |
| 16D         | Bridge Cover-6ft.                               | XLH-636-6       |
| 17          | Bridge Cover Pylon                              | XLH-733-1       |
| 18          | Stanchion Cover-R/H                             | XLH-659-1       |
| 19          | Stanchion Cover-L/H                             | XLG-660-1       |
| 20          | Control Panel Cover                             | XLH-640         |
| 21          | Connection Box Assembly, - 4ft Electric (Shown) | XLH-737-42      |
| 21A         | Connection Box Assembly, - 2ft Electric         | XLH-731-2       |
| 21B         | Connection Box Assembly, - 3ft Electric         | XLH-737-32      |
| 21C         | Connection Box Assembly, - 5ft Electric         | XLH-737-52      |
| 21D         | Connection Box Assembly, - 6ft Electric         | XLH-737-62      |
| 21E         | Connection Box/Flue Assembly, - 2ft Gas         | XLH-735-22      |
| 21F         | Connection Box/Flue Assembly, - 3ft Gas         | XLH-735-32      |
| 21G         | Connection Box/Flue Assembly, - 4ft Gas         | XLH-735-42      |
| 21H         | Connection Box/Flue Assembly, - 5ft Gas         | XLH-735-52      |
| 21 i        | Connection Box/Flue Assembly, - 6ft Gas         | XLH-735-62      |
| 22          | Bumper  | 70805-04        |
| 23          | Bridge to Hood Wire Conduit                     | XLH-734         |
| 24          | Spring Rod                                      | XLH-703-4       |
|             | Hood Mercury Tilt Switch Svc Kit                | SKXLH7401       |
|             | Switch, Mercury Tilt, Hi-Temp (Switch Only)     | 30307-04        |

# WIRING DIAGRAM

## Single-Phase Bridge

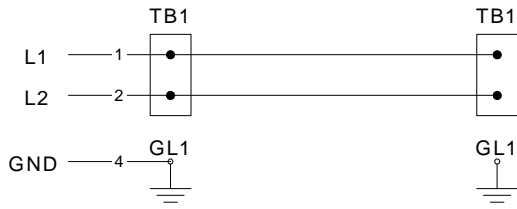

| SYMBOL | DESCRIPTION               | SYMBOL | DESCRIPTION             |
|--------|---------------------------|--------|-------------------------|
| CS1    | Current Sensor            | PL1    | Indicator Light, White  |
| GL1    | Ground Lug, Bridge        | PL2    | Indicator Light, Green  |
| GL2    | Ground Lug, Control Panel | PL3    | Indicator Light, Yellow |
| GL3    | Ground Lug, Hood          | SW1    | Toggle Switch           |
| HE1    | Heating Element           | SW2    | Plunger Switch          |
| HE2    | Heating Element           | TB1    | Terminal Block          |
| ILC    | Interlocking Contactor    | TB2    | Timer Plug              |
| MR1    | Mechanical Relay          |        |                         |

