

Manitowoc

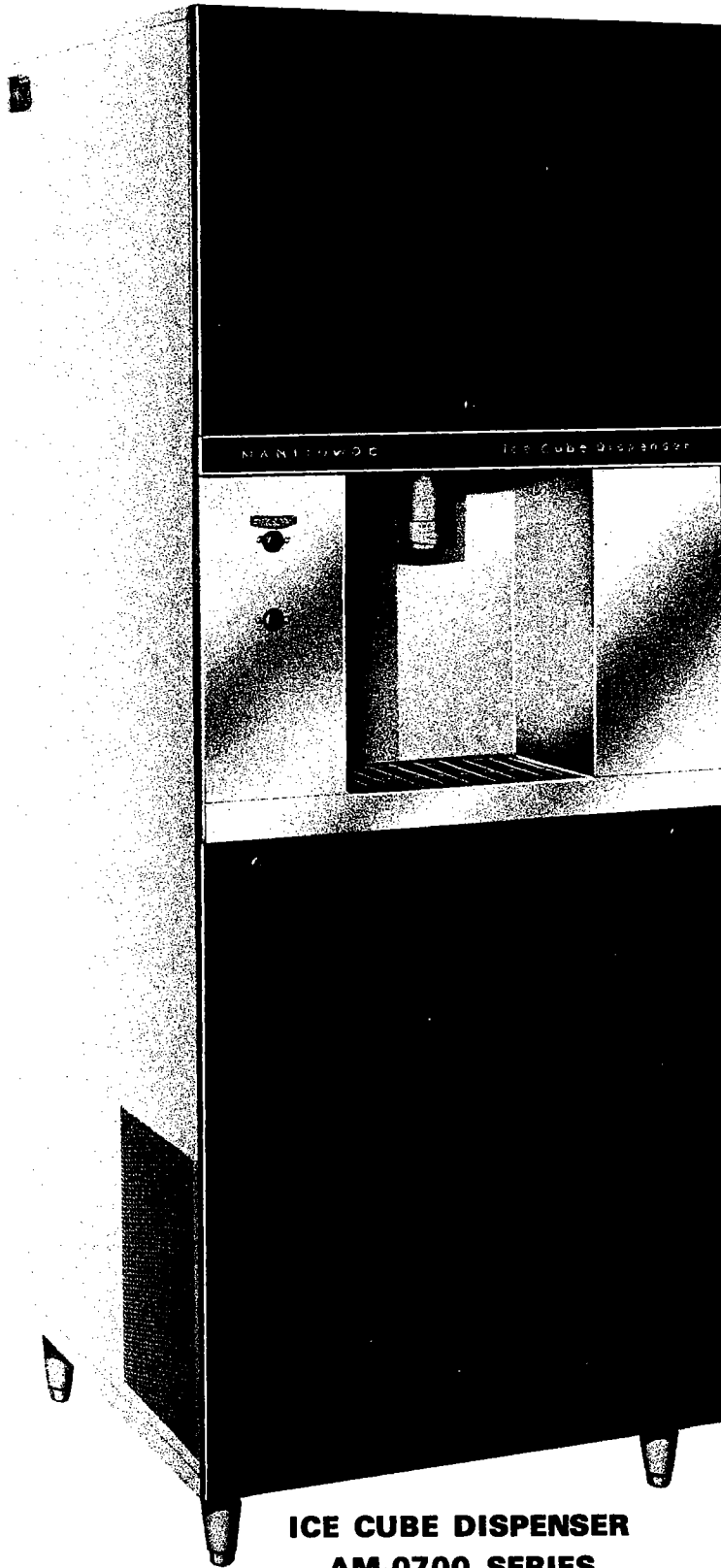

**ICE CUBE DISPENSER
AM-0700 SERIES
606 LEGS**



**MAXIMUM
ICE PRODUCTION!**

**GREATER STORAGE
CAPACITY!**

**SANITARY
APPROVED!**

**SUPERB NEW
STYLING!**



TABLE OF CONTENTS

	Page
Uncrating and Inspection	3
Location and Installation	3
Electrical Supply	3
Connecting Power Supply	3
Connecting Water Supply	3
Drain Connections	3
Serial and Electrical Plate	3
Check List for Starting Machine	3
Manitowoc Freeze and Harvest Control	3
Controls	4
Toggle Switch	4
Setting Timers	4
How Dispenser Works.....	4
Removing Auger Assembly	5
Replacing Auger Assembly	5
Removing Auger Drive Assembly	5
Condensing Unit — Fig. 5	10
Dispenser with Front Panels Removed — Fig. 2.....	7
Specifications	2
Timer — Fig. 5 & 15.....	10 & 20
Auger Drive Assembly — Fig. 6	11
Ice Making Section — Fig. 4 & 6	9 & 11
Dispenser Installed — Fig. 1.....	6
Cleaning Instructions	21
Electrical Specifications.....	22
Service and Parts Procedure.....	23
Service Analysis	24
Wiring Diagrams	25
Water System Sketch — Fig. 12 & 13.....	17 & 18
Warranty and Protection Plan	26

FORWARD

Manitowoc Equipment Works, Division of The Manitowoc Company, Inc., Manitowoc, Wisconsin, presents this Service Manual to assist the service man with information concerning CONSTRUCTION, INSTALLATION, and MAINTENANCE of the MANITOWOC AM-0700 SERIES ICE CUBE DISPENSER.

The problems of the user and the service man have been given special emphasis in the development of the latest MANITOWOC Ice Machines.

If you encounter a problem which is not answered by this manual, please feel free to write or call the Service Department of the Manitowoc Equipment Works, Division of The Manitowoc Company, Inc., Manitowoc, Wisconsin 54220, describing the problem you have encountered. The Service Department will be happy to give you particularized advice and assistance. Whenever calling or writing, please state the complete model and serial number of the ice making equipment.

MANITOWOC EQUIPMENT WORKS
Div. of THE MANITOWOC CO., INC.
Manitowoc, Wisconsin 54220

MODELS

This manual includes the following models.

AM-0711A

Push Button Ice Control — Air Cooled

AM-0712A

Key Ice Control — Air Cooled

AM-0713A

Push Button Ice and Water — Air Cooled

AM-0721W

Push Button Ice Control — Water Cooled

AM-0722W

Key Ice Control — Water Cooled

AM-0723W

Push Button Ice and Water — Water Cooled



AM-0700 SERIES

ICE CUBE DISPENSER

SPECIFICATIONS

ICE PRODUCTION	Up to 680 lbs. per 24 hours
BIN CAPACITY	275 lbs.
ICE SIZE	Dice 7/8" Cube
HEIGHT — with 6" legs	80 inches
WIDTH	30 inches
DEPTH	32 ³ / ₄ inches
APPROXIMATE SHIPPING WEIGHT	461 lbs.
COMPRESSOR	1 H.P.
** ELEC. CHARACTERISTICS	208-230 Volt — 60 cy. single phase (AC)
AUGER	4 inch
FINISH	Fawn Baked Enamel Front Panel Walnut Grained Vinyl

**** Connect to 20 Amp Circuit.**

UNCRATING AND INSPECTION

The "AM-0700" Series Cube Dispenser is shipped in a heavy cardboard carton to help prevent damage in transit.

Inspect carton thoroughly before uncrating, for punctures or damage. To uncrate cabinet, remove the band along the lower edge of carton. Remove the carton by sliding up and off of cabinet. Remove the corner posts and the inner carton.

Inspect cabinet for possible concealed damage. If damage is evident notify carrier at once for inspection.

Remove the four skid bolts from the bottom of cabinet, and remove skid. Unpack the four bin legs, packaged inside of cabinet. Screw these legs into the same holes at bottom of bin where skid bolts were removed.

LOCATION AND INSTALLATION

After legs are securely in place, locate Dispenser Bin in desired location. Once bin is located, allowing a minimum of 4 inches on all sides for air circulation, level bin side to side and front to back.

Remove the front panels, top and bottom with the keys supplied. Remove the packing from beneath water pump, and all tape from splash curtain and damper door assembly. Also remove the compressor blocks and the shipping block at the top of auger.

ELECTRICAL SUPPLY

208-230 Volt — 60 Cycle — 1 Phase 20 amp outlet — AC.

CONNECTING POWER SUPPLY

From right side of machine place No. 12 separately fused, 3 wire cable, through the electrical supply hole (Fig. 3A).

Connect the wires to the lead wires (Fig. 5A) in the compressor compartment.

Replace cover on electrical box.

CONNECTING WATER SUPPLY

Connect the water supply line to the 1/2 inch N.P.T. female fitting located in the bottom of the dispenser (See Fig. 3B). A water strainer is supplied with dispenser.

GENERAL REQUIREMENTS

All electrical and water supply and drain connections must conform to local codes.

DRAIN CONNECTIONS

It is essential that drain connections be made so waste water can't back up into the head unit or bin. On water cooled models, a separate

connection is provided for discharging condenser water. (See Fig. 3C.) All connections are labeled. We recommend covering all incoming water and drain lines with a plumbing insulation material to prevent condensation.

Tee the two (2) bin drains, located at the bottom rear of dispenser together. We recommend 3/4" common drain line be used. (See Fig. 3D and Fig. 14A.)

SERIAL AND ELECTRICAL PLATE

The combined serial and electrical plate is located on upper left side of cabinet. (See Fig. 1A.) Be sure to send complete model and serial number of the dispenser when calling for parts or service.

CHECK LIST FOR STARTING MACHINE

Turn on water, and observe that the float valve (Fig. 6H) shuts off the water when the level is about 2 inches deep. Should float require adjustment merely bend float rod carefully until desired water level is achieved. Turn the toggle switch (Fig. 5B) to "water pump" position.

The water pump will start pumping water into the water distributor tubes located at the top of the evaporators. Return water will flow into the sump and back to the water pump.

CHECK FOR THE FOLLOWING THINGS

A higher than necessary water level wastes water and reduces ice making capacity.

Turn the machine on and off several times to flush clean water through the system and to observe that waste water drains properly.

With the toggle switch in the "ICE" position, reach in and push the damper door open. The entire machine should stop and remain off until the damper is released.

Observe one ice cycle before replacing front panels.

The ice size controls consist of a Ranco or Penn reverse-acting pressure control (opens on pressure rise) and a Paragon time clock. These controls are factory set and should need no adjustment except in altitudes above 5,000 feet.

MANITOWOC'S FREEZE AND HARVEST CONTROL FOR AM-0700 ICE DISPENSER

Freeze and harvest cycles on the above model Manitowoc Cuber is regulated by three very simple controls. The basic control is a low side reverse-acting pressure regulator made by either Ranco or Penn. The second control is a Paragon Timer located in the top of the ice machine. The third is a thermo disc installed on the suction line outlet of the evaporator. On starting a warm machine, the suction pressure may be upwards of

75 PSIG; but as the compressor runs, the suction pressure and temperature within the line is lowered. When the line temperature reaches 35 degrees F., the thermo disc "cuts in" and closes the clutch on the timer and holds it "in" continuously through the freezing cycle. When the suction pressure reaches 14 lbs., the pressure control electrically activates the timer motor. The cam on the timer motor is set at approximately 4½. This is equal to 6½ minutes running time. The clock continues to run until the cam stalls against the harvest micro switch. This places the unit in harvest, and it will stay in harvest until released by the bin damper switch when the sheet of ice falls into the bin. The thermo disc remains closed during the entire harvest cycle. It opens only when the temperature of the suction lines rises to 65 degrees. This is a safety measure to prevent overheating in case the unit would stay in harvest. due to a faulty bin damper switch.

If the dimple in the cubes is too pronounced, you may set the timer dial to 5. This will increase the freezing time. Likewise, if the bridging between cubes is too heavy, you may set the dial back to about 4. This shortens the freezing time.

CONTROLS

High Pressure Cut-Out

This shuts entire machine off, should the head pressure exceed 275 PSIG. (See Fig. 5H.)

Suction Line Thermo Disc

Suction line thermo disc is a safety control located on suction line. This control is a Klixon switch that opens at 75°F + -5° and closes at 40°F + -5°. The thermo disc acts only as a safety device to prevent overheating of the machine. Should the damper door switch fail after harvest, the thermo disc will open. Then the suction line temperature reaches 75°F + -5° this will return the machine to its normal freezing cycle by disengaging the clock clutch located on the clock.

Toggle Switch

The main power "ON and OFF" toggle switch (Fig. 5B) is a double pole, double throw switch with "OFF" in the center position. With the toggle switch in the "water pump" position, only the water pump and the condenser fan operate. This is for checking the water inlet float level, pump operation, and for circulating cleaning solution.

With the toggle switch in the "ICE" position, the water pump, compressor, and condenser fan (air cooled models), run for a normal ice making cycle.

Ranco or Penn Pressure Control

This control (Fig. 5E) is a reverse-acting pressure control that opens on pressure rise. Upon decrease in suction pressure to 11 PSIG, the pressure control closes, actuating the time clock.

Paragon Time Clocks (Primary and Secondary)

After the pressure control energizes the time clock, the time clock motor turns a cam for 6½ minutes (number 4½ on the time clock face). When the 6½ minutes have elapsed, the cam trips a micro switch which in turn cycles the front evaporator into hot gas or harvest cycle. Simultaneously, the water pump and condenser fans shut off. Also the secondary timer starts and operates for 30 seconds. At the end of 30 seconds, the back evaporator cycles into harvest. (See Fig. 14.)

Damper Door Switch (Fig. 6L)

When the harvest is completed, the ice falls through the damper door tripping the damper door switch. This, in turn, opens the holding clutches on the time clocks momentarily to reset the clocks and return the machine to its normal freezing cycle.

When the ice bin is full, the ice holds the bin switch open keeping the machine shut off.

Should the damper switch fail, the suction line thermo disc will open to reset the time clocks.

SETTING TIMERS

Should it be necessary to adjust the timer for an accurate bridge thickness, proceed as follows:

1. Remove the control box cover (Fig. 5).
2. Locate the primary timer (Fig. 5C).
3. Loosen adjustment screw (Fig. 14D).
4. To decrease bridge thickness, set arrow (Fig. 14C) to number 3. Likewise to increase bridge thickness, set arrow to number 5.
5. Retighten set screw.

Fig. 5D indicates the secondary timer. This timer should not be adjusted. The primary timer (Fig. 5C) controls the bridge thickness of both evaporators.

HOW THE DISPENSER WORKS

Manitowoc has designed its AM-0700 Series Combination Ice Dispenser Bin to manufacture, store and deliver up to 680 lbs. of crystal clear ice cubes per 24 hours. The cube is a 7/8" dice cube.

After the dispenser bin is installed, allow the ice cuber to operate 4 to 6 hours before dispensing ice. When this time period has elapsed there will be a sufficient amount of ice in the bin to enable the ice to be dispensed.

To dispense the ice, hold the glass or container under the ice opening at front center of dispenser (Fig. 2A). Push the ice button (Fig. 2B) or turn the key control to begin ice delivery. When the required amount of ice is delivered, merely release the button or key to discontinue ice delivery.

If bin is equipped with optional water controls, push the button (Fig. 2C) or trigger for the desired amount of water required in the container.

The cuber delivers its ice into the Dispenser Bin in its normal manner. The auger, by revolving, conveys the ice to the ice opening. The ice then falls through this opening and into the container. The auger is driven at a slow RPM by a 1/3 HP motor through a speed reducing gear train located in the compartment above the storage bin. (See Fig. 6A.)

The opening in the ice delivery chute is designed to reject ice cubes, frozen together, to avoid jamming of the ice chute opening. These rejected cubes are either sheared by the chute or are dropped off the auger to the bottom of bin to be re-dispensed.

When ice is dispensed from the bin it is replaced by the ice cuber at the rate of approximately 680 lbs. daily (24 hours). This continual falling of ice into the storage bin, keeps the ice loose for maximum dispensing capacity of dispenser.

The water created by some melting of the ice is drained out of the bin through the drain located at the back of the Dispenser. The other drain is for the waste pan and bin condensate. (See Fig. 3D and 13A.)

REMOVING AUGER ASSEMBLY

To remove the auger assembly for cleaning or maintenance proceed as follows:

1. Remove top front panel.
2. Remove the four ice chute extension screws marked "B" in Fig. 6 and remove chute extension.
3. Remove the two bolts marked "D" and the four bolts marked "C" in Fig. 6.
4. Disconnect the drive motor electrical leads and lift entire gear drive assembly up and out of dispenser.
5. Remove the two bolts on each side of the auger chute (Fig. 6).
6. Lift the auger assembly up and out of Dispenser as indicated in Fig. 8.

REPLACING AUGER ASSEMBLY

To replace the auger assembly, insert assembly back into bin. Be sure the two pins at the bottom of the auger assembly slide into the two holes in the bracket at the bottom of bin.

Install the drive assembly and ice chute extension in reverse order as removed.



A. Serial number plate.

FIG. 1

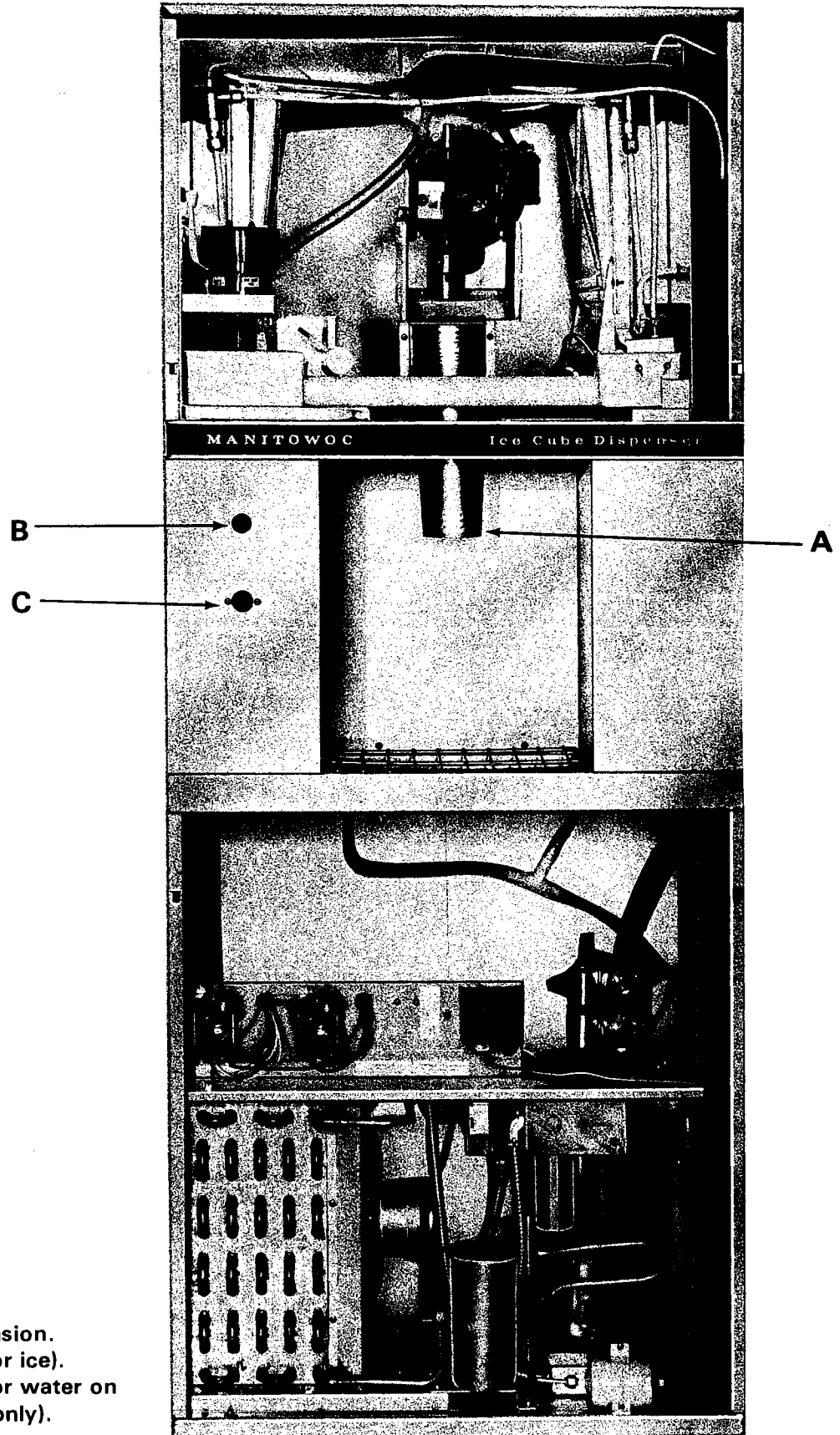

FIG. 2

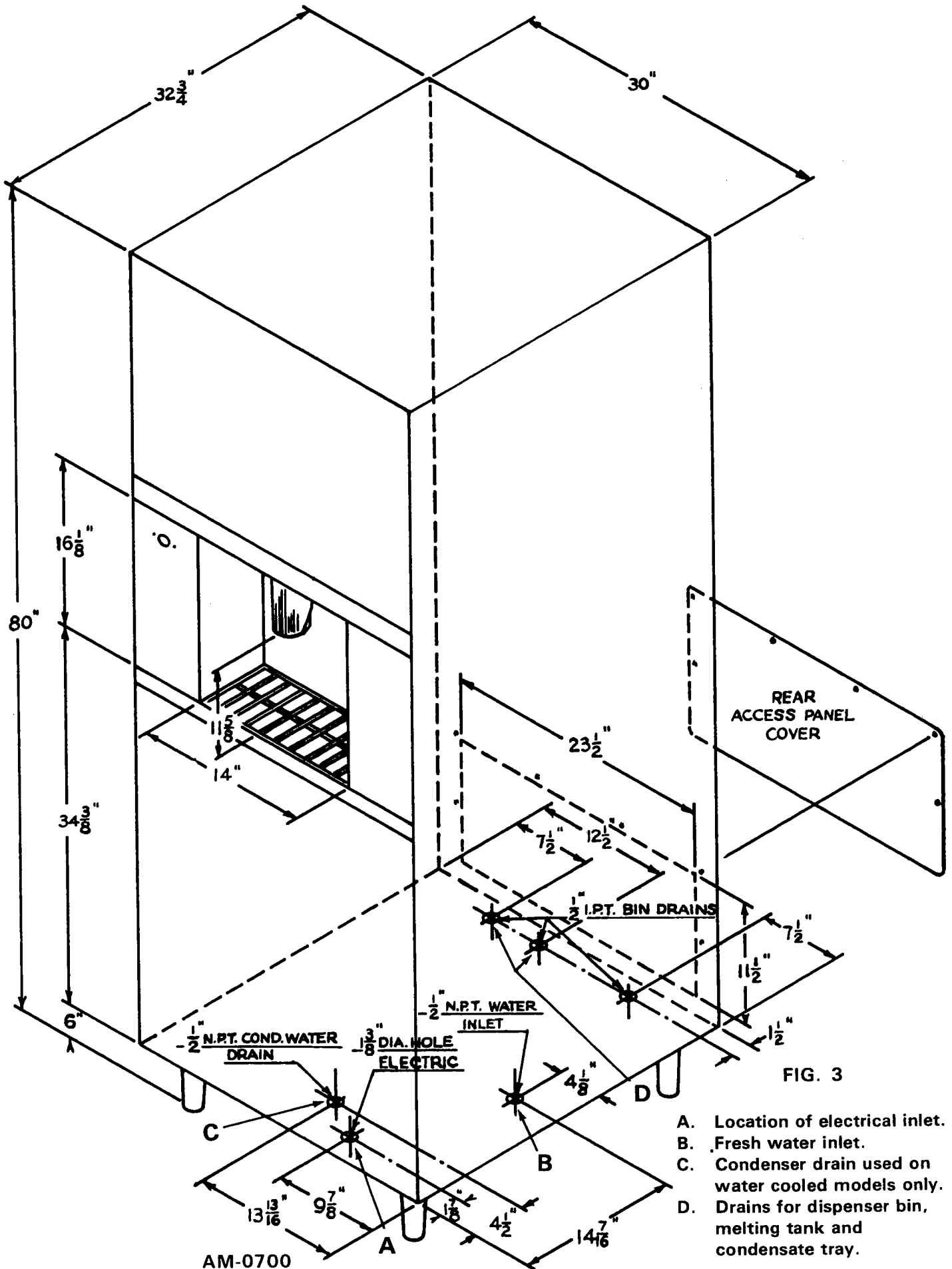

FIG. 3

AM-0700
SELF CONTAINED ICE CUBE DISPENSER

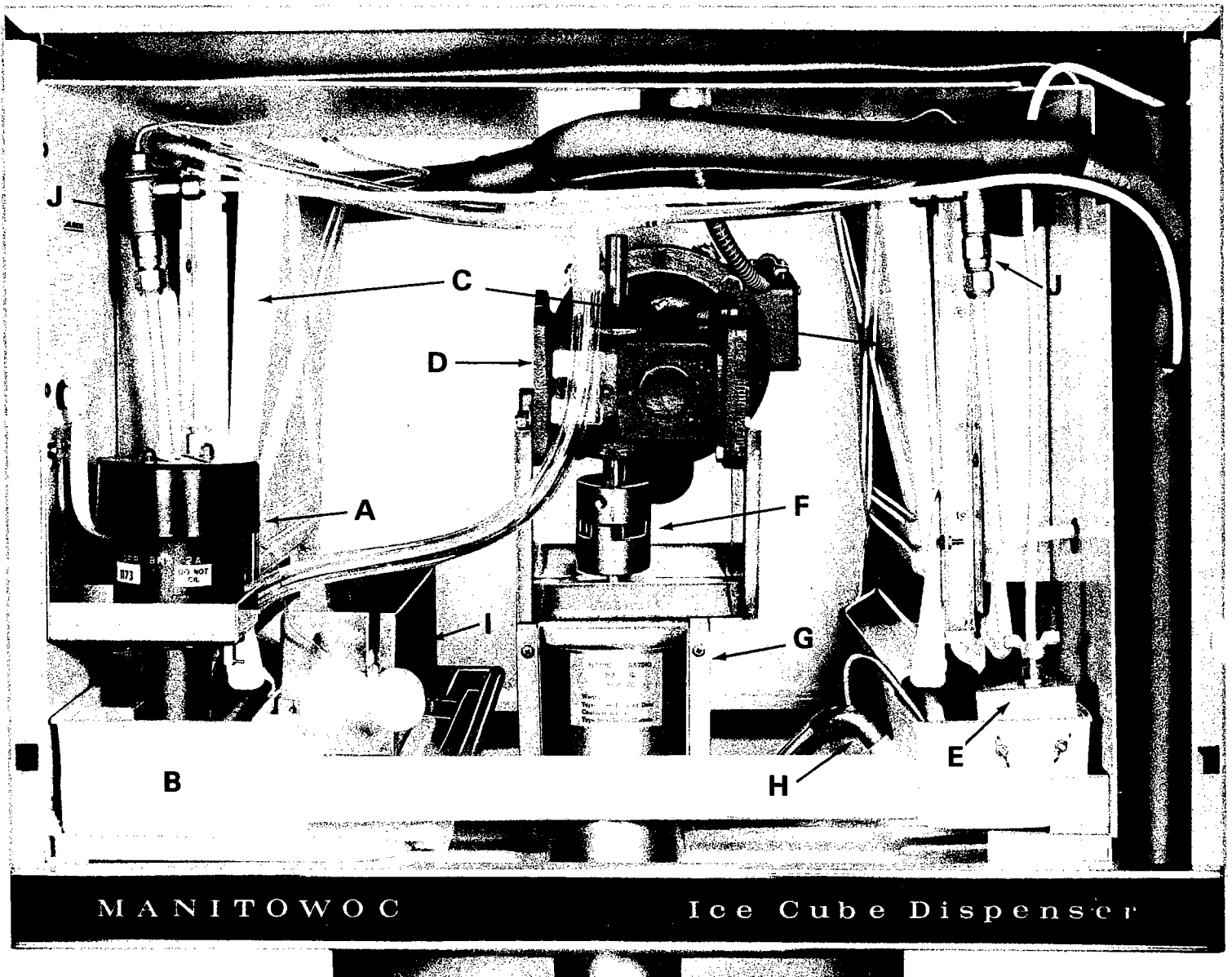

FIG. 4

- A. Water pump.
- B. Sump trough assy.
- C. Water curtain.
- D. Gear drive and motor assy.
- E. Float valve.
- F. Gear drive and auger coupling.
- G. Auger ice chute and ice chute extension.
- H. Water syphon.
- I. LH ice chute and damper door assy.
- J. LH and RH expansion valves.

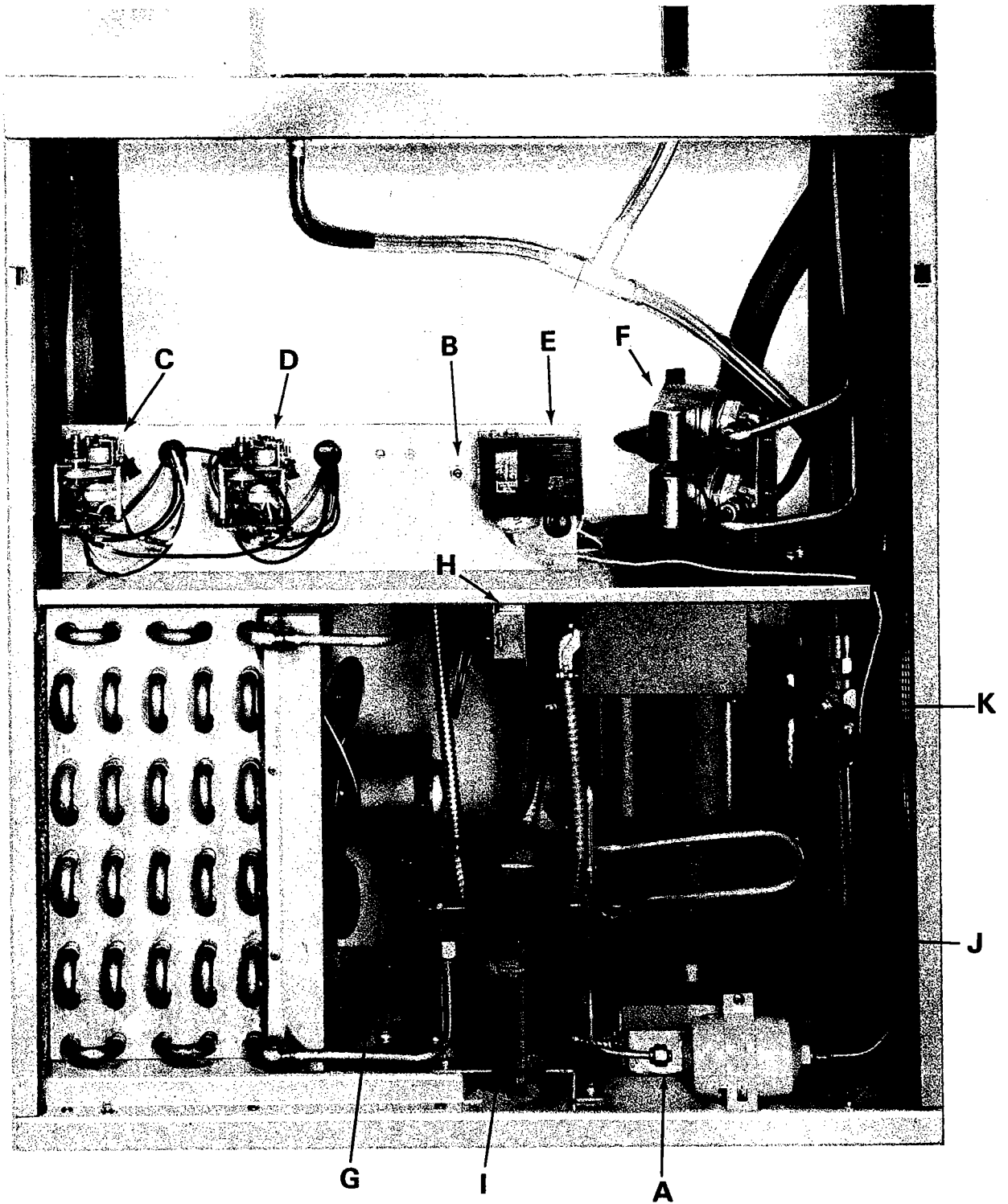

FIG. 5

- A. Electrical supply box.
- B. Main toggle switch.
- C. Primary timer 15 min.
- D. Secondary timer 60 second.
- E. Ranco low pressure cut-in.
- F. Hot gas defrost valves.
- G. Fan motor and blade and bracket.
- H. High pressure cut-out.
- I. Receiver.
- J. Compressor assy.
- K. Low side service valve.

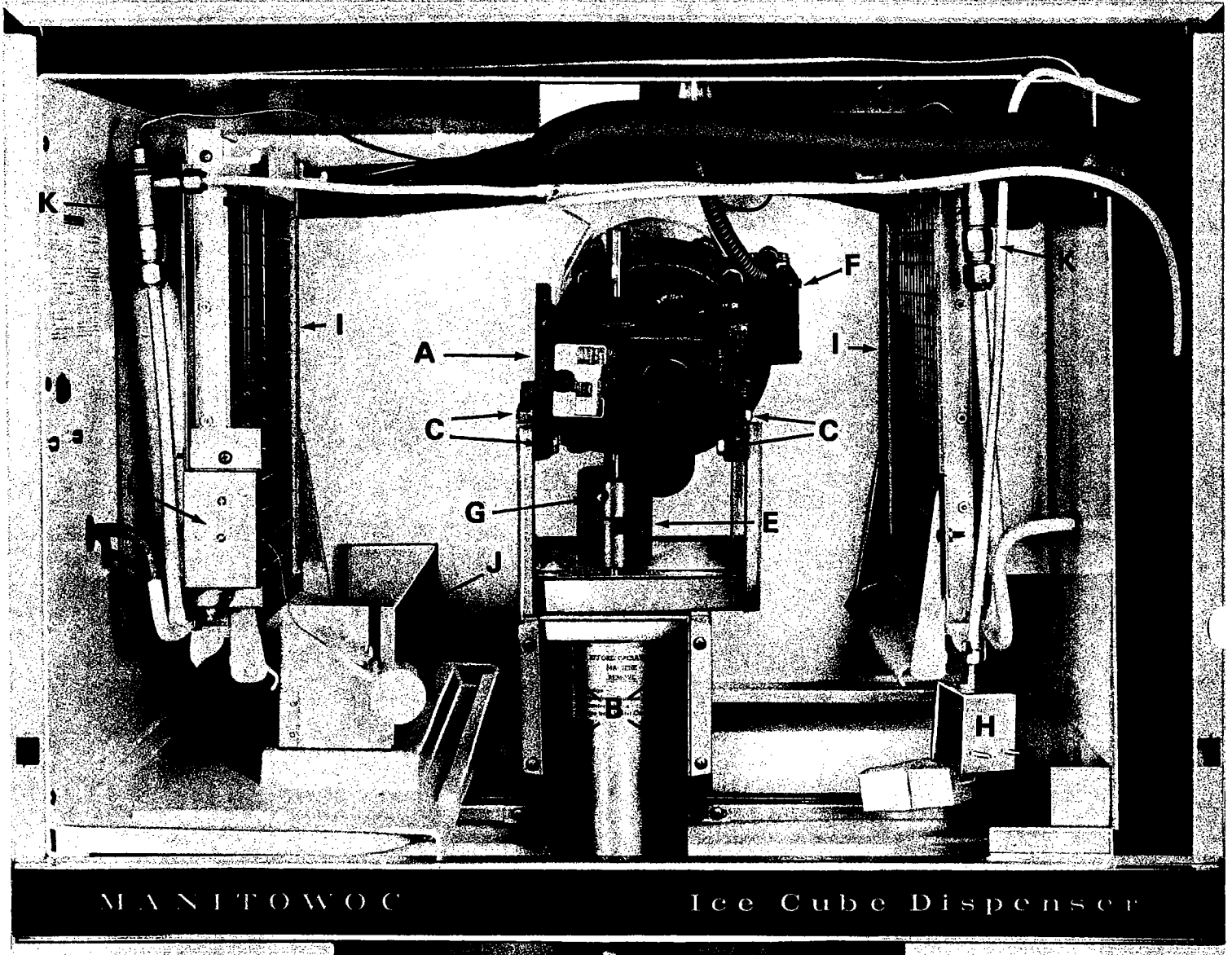
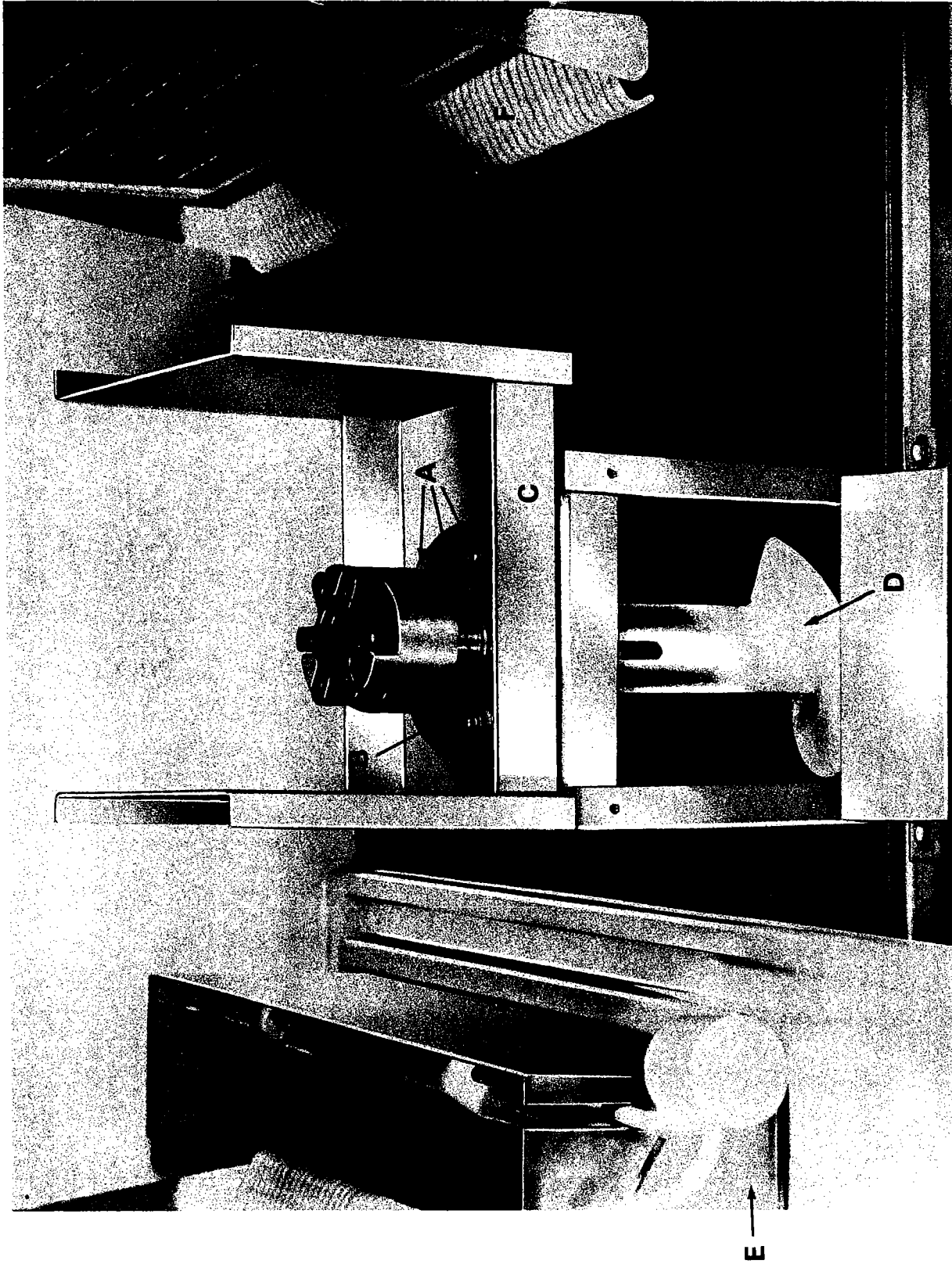

FIG. 6

- A. Gear drive and motor assy.
- B. Ice chute extension mounting screws.
- C. Auger ice chute extension mounting bolts.
- D. Gear drive motor rear mounting screws and plate.
- E. Drive coupling.
- F. Gear drive motor electric junction box.
- G. Drive coupling set screw for gear drive shaft.
- H. Float valve.
- I. LH and RH evaporators.
- J. Ice chute and damper door assy.
- K. Expansion valves (for LH and RH evaporator)
- L. Damper door switch.



- A. Upper bearing assy. and upper auger ice chute extension mounting bolts.
- B. Upper bearing assy.
- C. Upper auger ice chute extension.
- D. 4" auger.
- E. LH ice chute with damper door.
- F. Harvest rack R.H.

FIG. 7

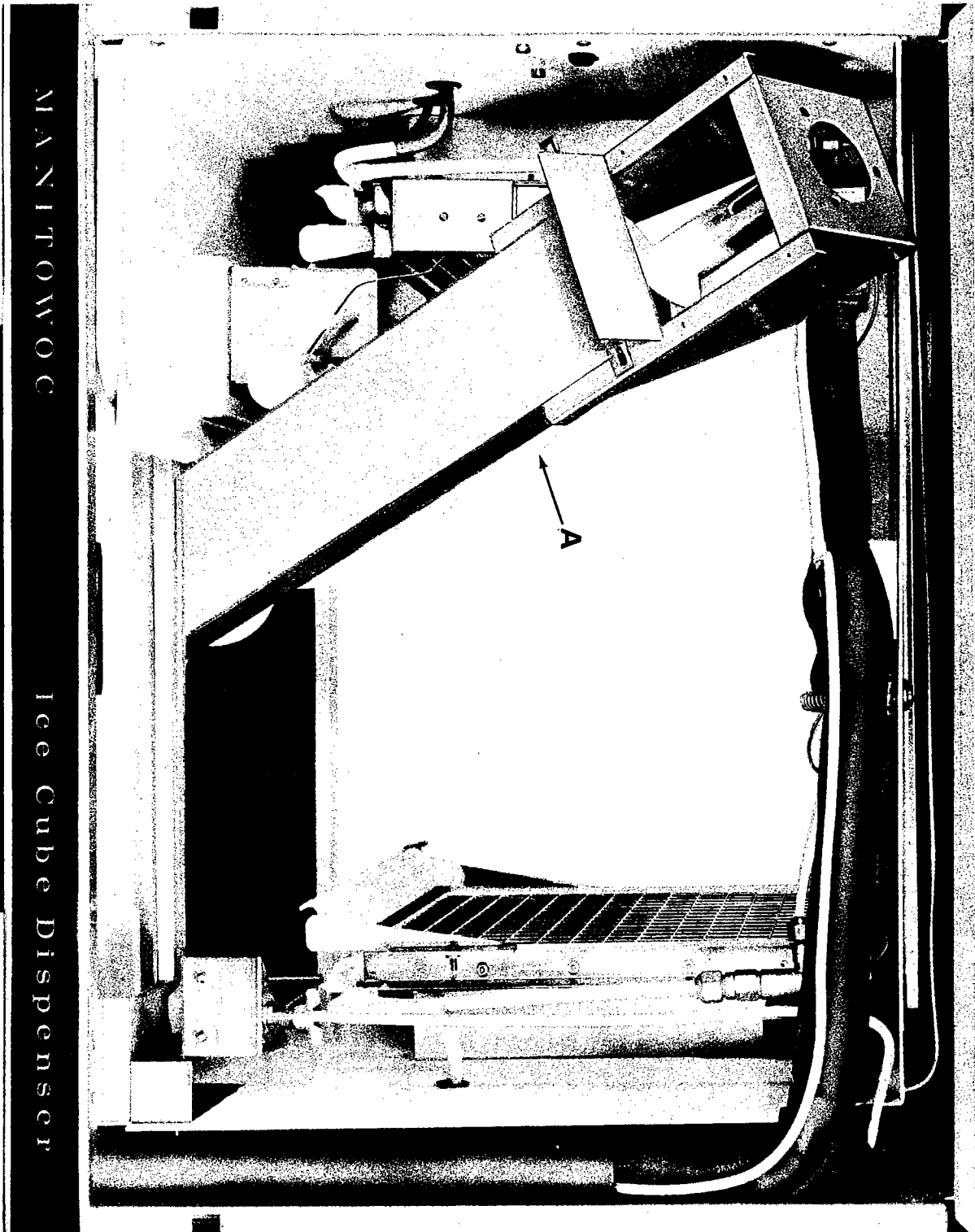
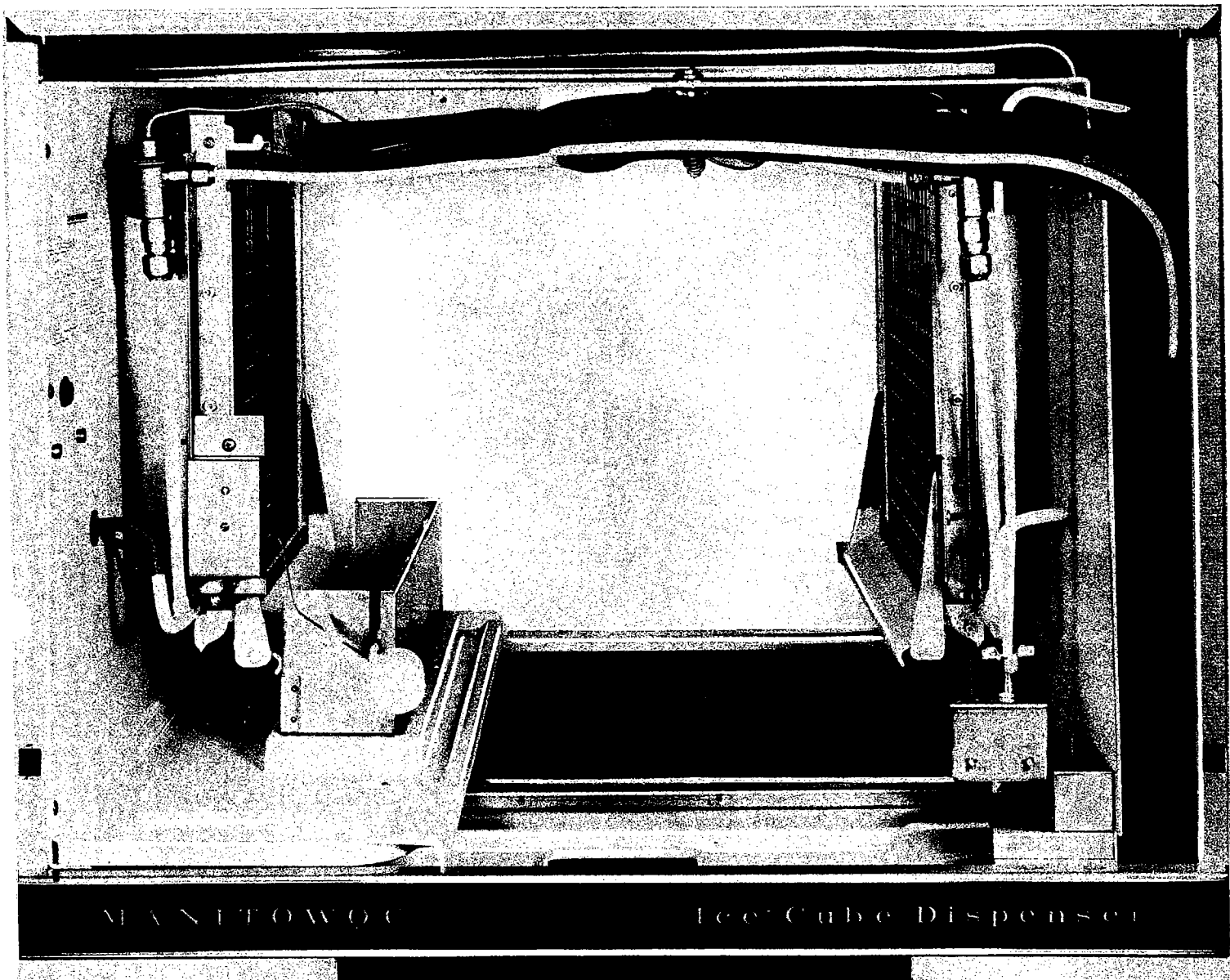
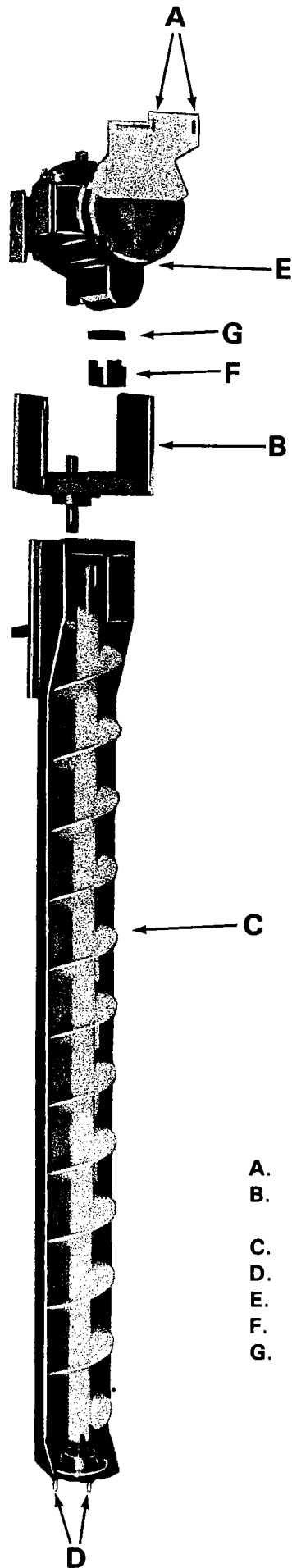

FIG. 8
A. Auger ice chute assy. in removal position from bin.



Upper section with gear drive and motor assy., sump trough, water pump, water curtains and auger ice chute assy. removed.

FIG. 9



- A. Gear drive motor rear mounting bracket.
- B. Auger ice chute upper extensions with upper bearing housing assy.
- C. 4" auger and ice chute.
- D. Lower ice chute mounting studs.
- E. Gear drive and motor assy.
- F. Lower section of drive coupling.
- G. Drive spacer between the two sections of drive coupling.

FIG. 10

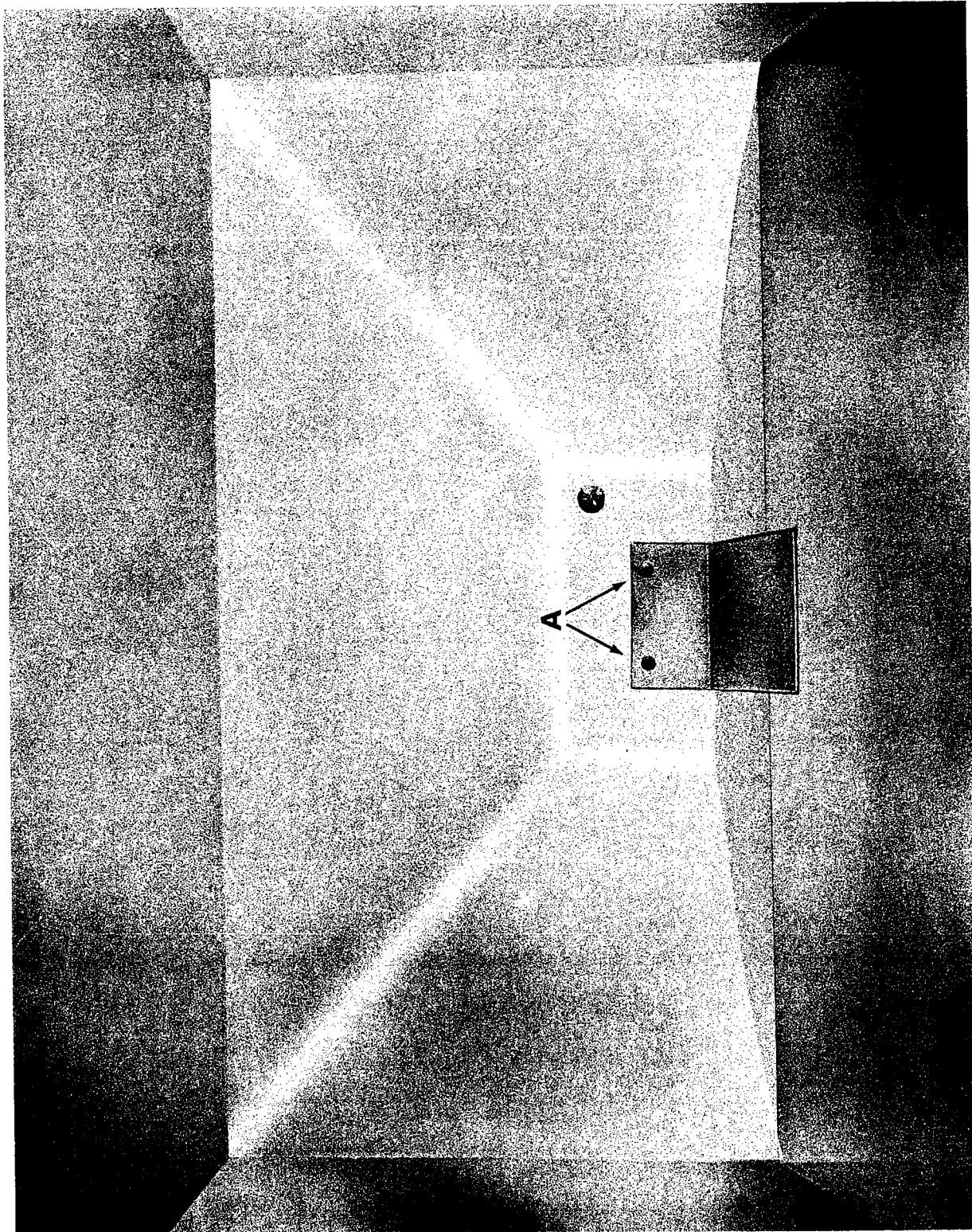

A. Ice chute lower mounting bracket located in bottom of bin.

FIG. 11

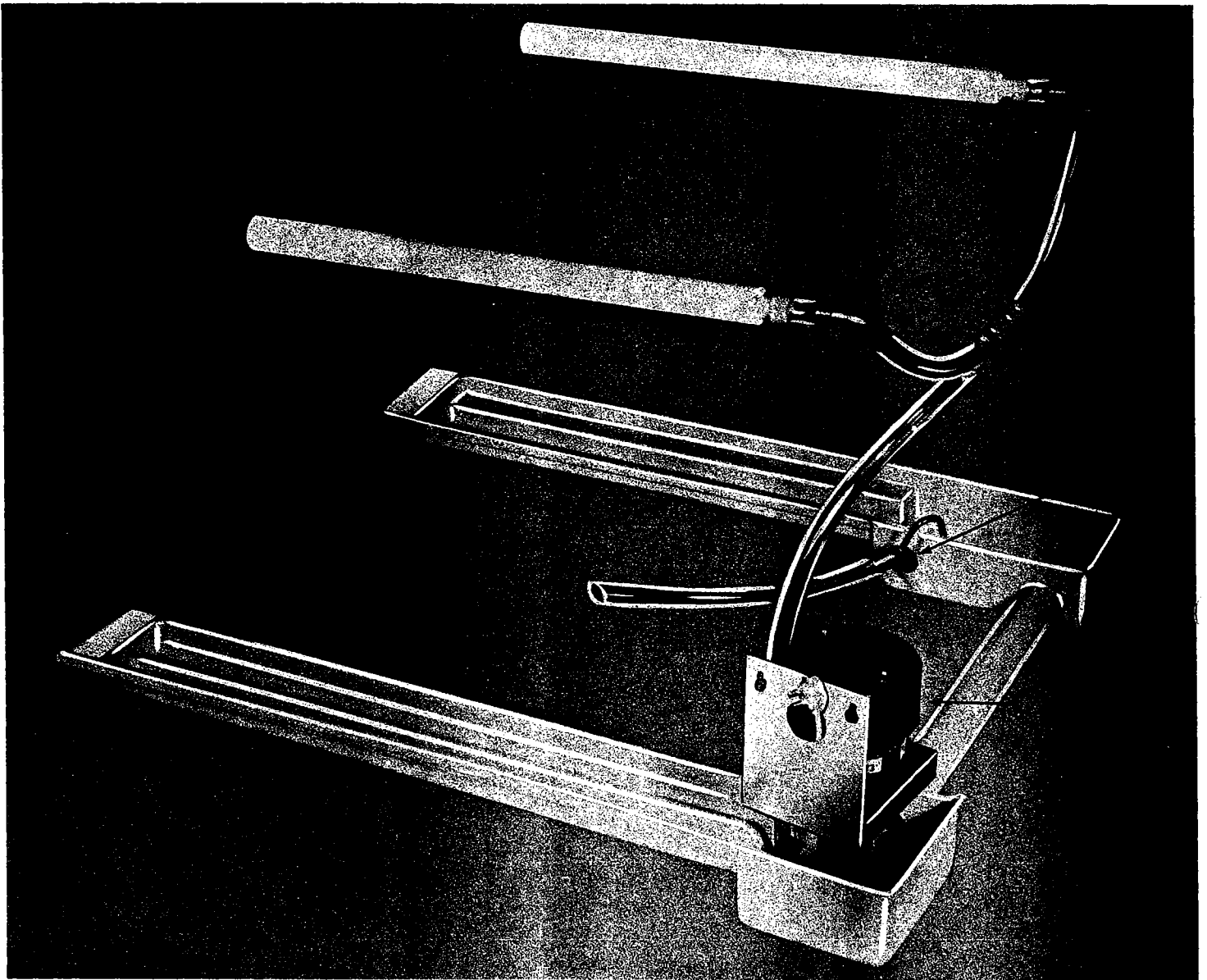
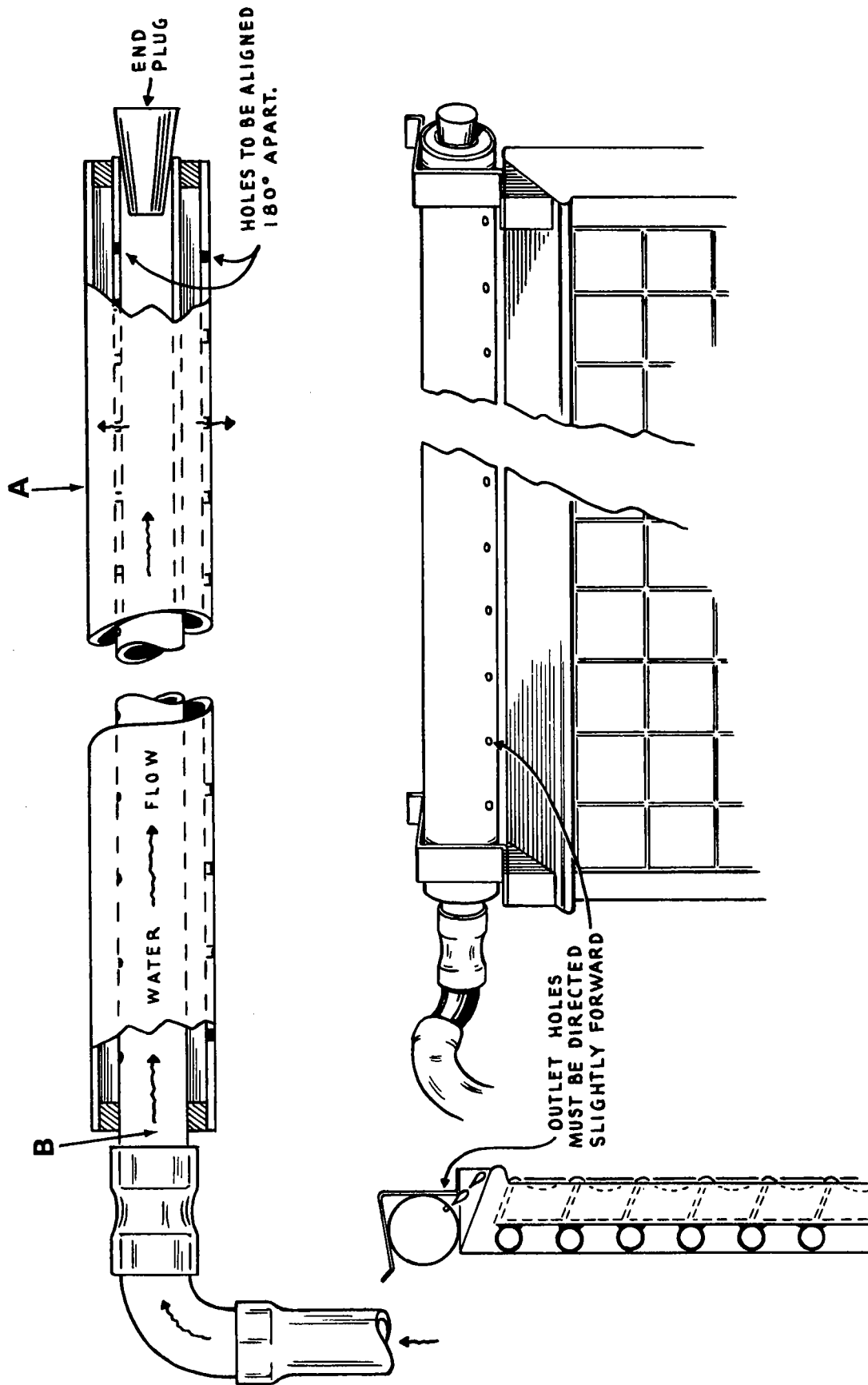

FIG. 12

- A. Water distributor tube assy.
- B. Sump trough.
- C. Water pump.
- D. Water syphon assy.
- E. Water supply tube.
- F. Water supply tee.



A. Water distributor tube.
B. Water restrictor tube.

FIG. 13

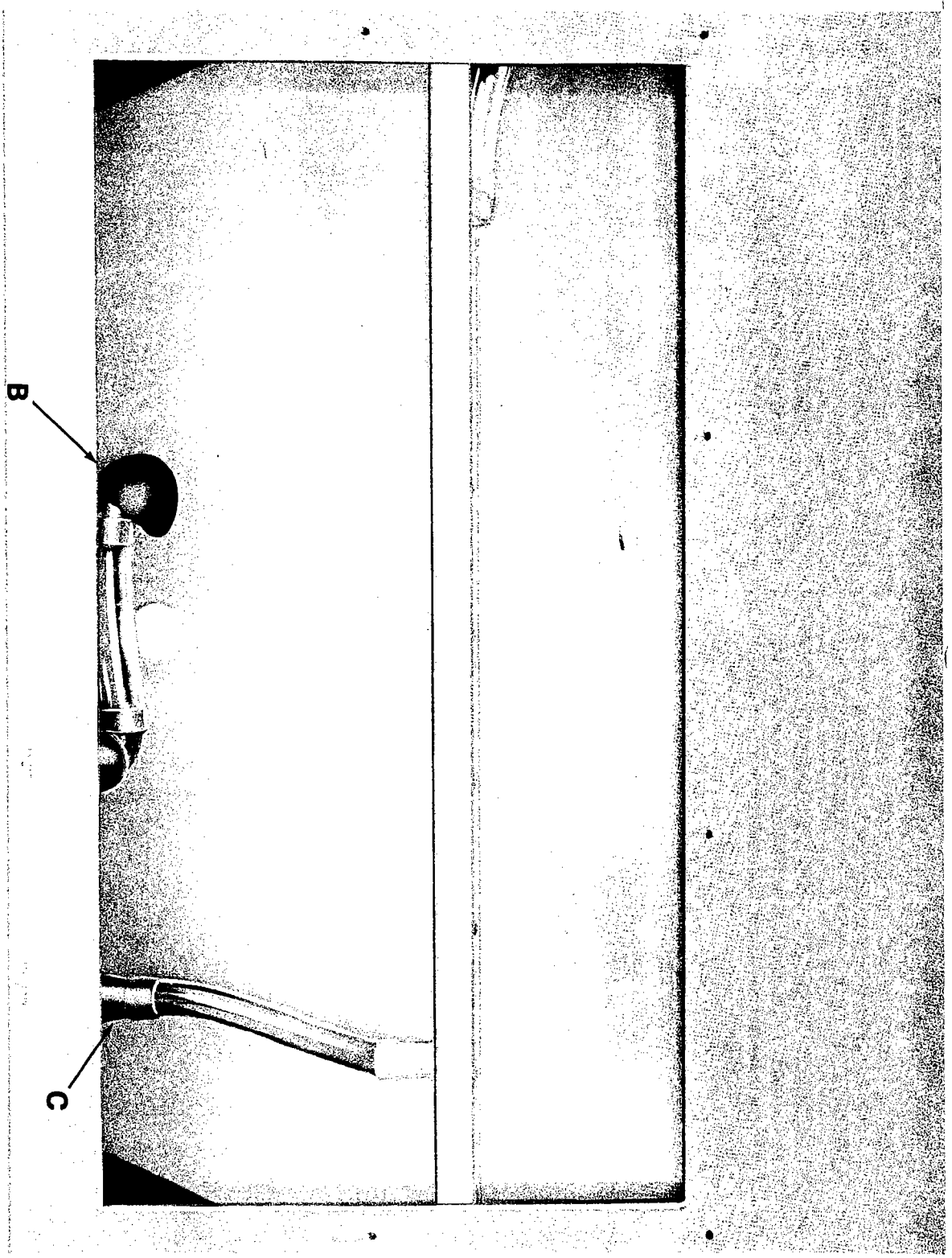

- A. Drain connection locations at rear bottom of dispenser.
- B. Bin drain.
- C. Drain for melting tank and condensate tray.



FIG. 14

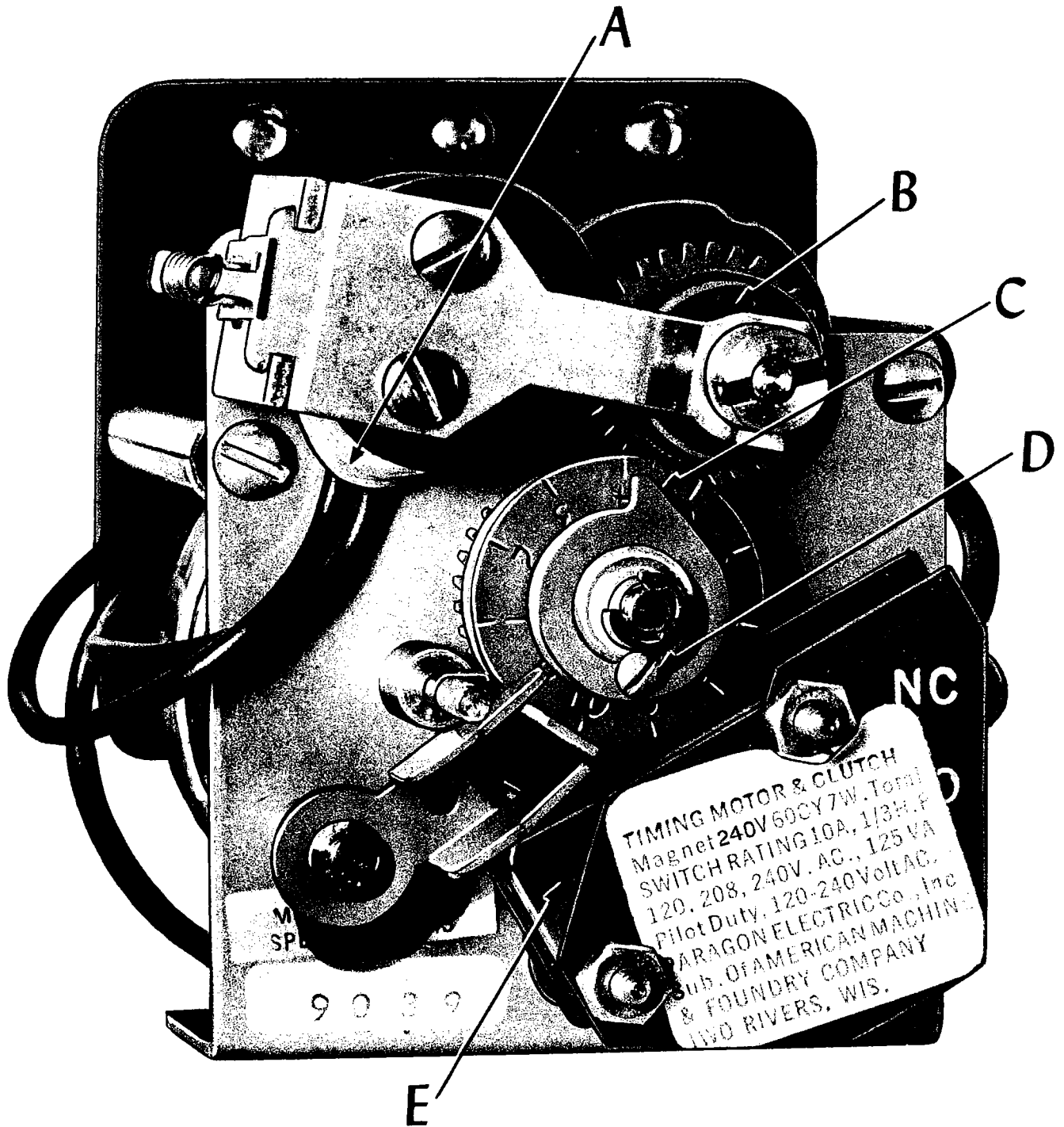

FIG. 15

Primary and Secondary Timer

- A. Clutch coil.
- B. Clutch.
- C. Timer setting dial.
- D. Timer setting lock screw.
- E. Micro switch.

CLEANING INSTRUCTIONS

WATER SYSTEM ASSEMBLY (See Fig. 12)

In Place Cleaning

To clean the ice cuber water system without removing the components proceed as follows. (NOTE — This is only recommended in locations where impurity build-up is not heavy.)

1. Remove ice cuber front panel.
2. Shut off ice cuber.
3. Remove ice from bin.
4. Shut off water supply and remove water from water sump.
5. Pour one bottle of ice machine cleaner into sump and turn supply water on.
6. Place toggle switch to water pump position and circulate cleaner for about 30 minutes.
7. After cleaning, shut machine off and remove cleaner. Flush water system thoroughly.
8. Clean ice storage bin with ice machine cleaner also.

Disassembling Water System for Cleaning

1. Shut machine off.
2. Remove splash curtains, water pump, water distributor and tubes (Fig. 12A).
3. Disassemble distributor as indicated in Fig. 13.
4. Disassemble water pump as follows: A. Turn pump over and remove the 6 brass thumb screws. B. Hold and depress impeller. Rotate plastic thumb nut counter-clockwise. C. Remove screws and pump housing. Pump is now ready for cleaning. D. Reassemble in reverse order as removed.

Scrub all parts removed using a nylon scouring pad, brushes, and a cleaning solution such as LIME-A-WAY from Economics Laboratory, Inc., Calgon Ice Machine Cleaner, or Boss Brand Milk Stone Cleaner from Northern Laboratories. Rinse all parts with clear water.

It is recommended that the ice be removed from the storage bin before scrubbing the base and evaporator assembly. Rinse with clear water. Check to see that overflow or drain hole in the base is clear and that water drains through freely.

Reassemble unit. To sanitize unit, mix ONE TEASPOON OF SODIUM HYPOCHLORITE IN ONE GALLON OF WATER. Pour solution into sump, then turn toggle switch to the left to start water pump.

Keep pouring solution into sump until system has enough to keep pump primed. After one minute, turn off pump and remove solution from water sump. Repeat with clear water before turning switch back to the ice making position. Make visual inspection for leaks and operation before replacing the front panel.

REMOVING GEAR DRIVE MOTOR AND AUGER ASSEMBLY FOR BIN CLEANING

To remove the auger assembly for cleaning or maintenance proceed as follows:

1. Shut off electric power to dispenser and remove top front panel.
2. Remove the four ice chute extension mounting screws from auger ice chute (Fig. 6B).
3. Remove 2 mounting screws from rear gear drive motor mounting bracket (Fig. 6D and 10A). These hold back of drive motor to top of cuber.
4. Disconnect drive motor electrical leads (Fig. 6F). Remove 4 mounting bolts, lock washers and hex nuts fastening auger ice chute extension to gear drive and motor assembly (Fig. 6C).
5. Lift the gear drive and motor assembly along with top half of drive coupling (Fig. 6A), 6#, up and off from lower half of drive coupling (Fig. 7). Because of the weight of this assembly be careful not to drop it into the bottom of the bin.
6. Remove the 3 bolts (Fig. 7A) holding upper bearing assembly and auger ice chute extension (Fig. 7C and 10C) to auger ice chute assembly (Fig. 10C).
7. Move ice chute and auger assembly to the left and lift up and out from dispenser bin. (See Fig. 8A and 10C.)
8. To replace the auger assembly, auger ice chute extension, upper bearing assembly, ice chute extension and gear drive and motor assembly reverse the above procedures 1 thru 7. To make it easier to line up the upper and lower drive coupling you may want to loosen the set screw (Fig. 6G).

SPECIFICATIONS

CUBER MODEL	AM-0711A AM-0712A AM-0713A AM-0700 Series Water Cooled 60 Cycle	AM-0721W AM-0722W AM-0723W AM-0700 Series Air Cooled 60 Cycle
Compressor Model	YSB4-0150-CFV	YSB4-0150-CFV
Compressor Voltage	208-230V 60Cy-1Ph	208-230V 60Cy-1Ph
Winding Resistance Common to Run	50 OHMS	50 OHMS
Winding Resistance Common to Start	4.6 OHMS	4.6 OHMS
Start Capacitor Rating MED/Volts	135-155/320V	135-155/320V
Run Capacitor Rating MED/Volts	25/370V	25/370V
Fan Motor Model		Elec. Motors & Specialty
Fan Motor Amps		.7 Amps
Fan Motor Watts		35 Watts
Fan Motor Volts		230V
Fan Winding Resistance		55 OHMS
Solenoid Valve Volts	230V	230V
Solenoid Valve Winding Resistance		
Hartell Water Pump Winding Resistance	35 OHMS	35 OHMS
Hartell Water Pump Amperage	.8 Amps	.8 Amps
Refrigerant Charge — R-12	50 Oz.	45 Oz.
Normal Machine Amperage		

SERVICE AND PARTS PROCEDURES

Order and Pricing Procedure

All replacement parts for the Manitowoc ice machine equipment are to be ordered directly from the factory; however, any distributors or dealers who may be interested in stocking replacement parts for the machines they sell, in order to provide their customers with a prompt and efficient service, may purchase these parts with the understanding that, any time they feel they have parts they no longer need or feel they no longer want to carry replacement parts, they are to notify the factory's Parts Department as to which parts they wish to return.

Upon receipt of this listing, we will immediately send them written authorization to return these parts; and upon receipt of these parts, full credit will be issued. There will be no charge for restocking these parts. Of course, credit can only be issued if the parts are returned in a new and unused condition.

When placing your order, be sure to do as follows:

1. Print name and address plainly.
2. If special routing is requested, please show the name of the carrier.
3. Indicate quantity desired, print catalogue part number plainly and print name as shown in the catalogue.
4. Indicate model and serial number of the unit. **The complete serial number is needed.**
5. If uncertain as to the proper part number, please give a complete description or sketch of the part and the location of the part which is needed.
6. Check to see that all required information is contained in your order to facilitate prompt shipment.

All replacement parts are shipped from the factory on a f.o.b. Manitowoc basis. It is company policy to bill for all field replacement parts, according to terms as specified by our Credit Department.

All parts orders will be honored by the factory and will be billed according to our parts list schedules.

Parts which are covered by our warranty policy are to be returned to the factory for credit, transportation charges prepaid. Upon receipt of these parts here at the factory, they will be inspected; and if they are found to be defective, in material and workmanship, under normal use and service, credit will be issued.

Transportation companies are responsible for damage in transit as all shipments are tendered to them in good condition; and our responsibility ceases upon receipt of a signed bill of lading from the carrier. If the shipment arrives in a damaged condition or is short, the delivering carrier should be notified immediately.

Return of Defective Parts

All defective parts returned to the factory, transportation prepaid, must be tagged with a return material tag properly filled in. It is especially important that the cabinet serial number be secured and recorded on the tag, securing as much information as possible about the nature of the defect to prevent any delays in issuing credit. All parts should be returned as they are removed from the cabinet and not mutilated or tampered with. The return material tags are provided on a no-charge basis by the factory upon receipt of your request.

Our warranty and protection plan does not apply to cabinets that are not registered; therefore, it is necessary that, upon completion of the installation of the cabinet, the registration card be signed on the date of installation and mailed promptly to the factory Service Department in order for the cabinet to be registered.

Return of Hermetically-Sealed Units

Extreme care should be used in servicing the hermetically-sealed mechanism. It is important that the trouble be correctly determined before the unit is changed. Be sure it is not the control, relay, or overload causing the trouble. The defect must be listed on the return material tag.

The inoperative assembly should be returned to the factory, freight prepaid, **making certain that all service valves and tubing are sealed properly so as not to let in dirt, air, or moisture into the system.** After inspection of the returned hermetic mechanism, if it has been determined that the reason for failure is the result of defective workmanship and material, credit will be issued. If a returned hermetic mechanism is found, after inspection, not to be defective, it will be returned to the sender, along with the necessary charges to cover the inspection, handling, and freight. Credit will not be allowed for defective mechanisms damaged from improper packaging or handling.

Return of Complete Machines

No complete machines may be shipped back to the factory for repairs without first securing prior permission from the factory. If an unauthorized shipment is received at the factory, it will be refused by our warehouse and immediately returned to the sender. Upon receipt of your request to return a cabinet, if we feel that your request is legitimate, you will be sent an authorized return label authorizing you to return this cabinet to the factory freight prepaid.

Service and Labor Charges

In accordance with our warranty and protection plan, which is included in each cabinet, this protection plan provided is available only through distributors and dealers who will be solely responsible for service and labor charges.

SERVICE ANALYSIS

COMPLAINT	CAUSE	CORRECTIVE MEASURES
Slow Harvest	Contaminated or limed water system Low Ambient (air cooled models) Water valve set too low	Clean water system Must be above 50° F Adjust water valve to 125 PSIG head pressure (on water cooled units) Replace water valve
High head pressure	Leaking water valve (water cooled models) Air in system Defective water valve (water cooled models) Defective fan (air cooled model) Water valve not properly adjusted Contaminated air cooled condenser Defective expansion valve	Evacuate and recharge Replace water valve Replace fan Adjust water valve Clean condenser Replace
High suction pressure	Contaminated condenser Defective fan Defective water valve (water cooled models) Moisture in system	Clean Replace fan Replace or adjust water valve Replace drier, evacuate, and recharge
Low suction pressure	Shortage of refrigerant Moisture in system Ambient too low for operation	Locate leak and repair Replace drier, evacuate system Must be above 50° F
Unit noisy	Fan shroud touching fan blade	Adjust fan mounting brackets
Ice maker will not stop when full of ice	Damper door not properly adjusted Defective damper door micro switch	Adjust damper door Replace damper door micro switch
Time clock will not operate	Ranco pressure control not closing or expansion valve holding open	Replace control or expansion valve
Time clock will not actuate harvest	Timer micro defective Thermo disc is not closed or low pressure control contacts not closed	Replace micro switch Check thermo disc & low pressure control contacts
Small cube bridge	Ranco pressure control not opening Leak in refrigeration system Timer setting set too low	Replace control, check timer Locate leak, repair, evacuate, and recharge
Machine will not cycle into harvest	Defective time clock clutch coil Defective time clock micro switch Defective thermo disc or thermo disc loose on suction line Defective pressure control Moisture in refrigerant system Defective hot gas solenoid	Replace timer Replace, or tighten on suction line Replace Replace drier Replace
Will not dispense ice	Power off Defective push button or key switch Motor defective Gear drive defective	Check main switch, fuses and wiring Check and replace if necessary Replace Replace
Drive motor operates but auger doesn't	Gear trim defective Set screw on coupling loose	Replace Tighten
Water will not operate	Defective solenoid Power off Water line plugged Defective switch	Replace Check power at water switch Check and clean Replace

AM 0700 DISPENSER MANUAL OPER.

SHOWN AT BEGINNING OF FREEZE CYCLE
FAN ON AIR COOLED ONLY 230V 60.CY

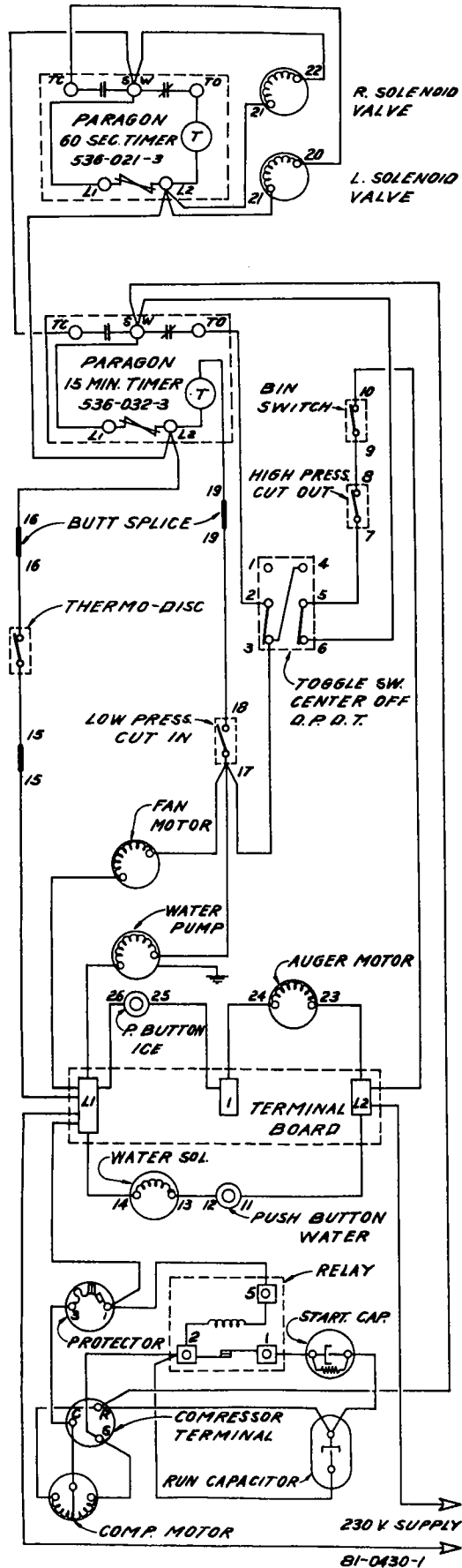

Ice Machine and Bin Warranty

From the date of original installation, we do hereby warrant each new Ice Machine and Bin to be free from defects in material and workmanship, under normal use and service, for a period of one year, and four additional years on the hermetic motor compressor in the Ice Machine.

Our obligation under this warranty is limited solely to correcting or replacing without charge at the factory in Manitowoc, Wisconsin any part or parts of this equipment which shall have been returned, transportation prepaid, and which our examination discloses to our satisfaction to be defective.

This warranty does not apply to any equipment that has been damaged by flood, fire, or suffered abuse, misuse, neglect or accident, or to any Ice Machine which has been altered so as to affect performance or reliability, except where such alteration has been accomplished with our prior written consent.

We further limit this warranty in that we shall not be held liable under this contract for any special, indirect, or consequential damages whatsoever resulting from any defect in material and workmanship which interferes with the normal use and service of such Ice Machine and Bin.

This warranty is a complete and exclusive statement of all terms of the agreement between the Manitowoc Equipment Works and the owner of the equipment, and all representations of the parties. This agreement shall not be varied, supplemented, qualified or interpreted by any prior course of dealing between the parties or by any usage of the trade.

Sales are made on the express understanding that there are no express or implied warranties other than the express warranty herein contained and that there are no implied warranties that the goods shall be merchantable or fit for a particular purpose other than the expressed one year and five year warranty set forth above.

To validate this warranty, the registration card must be signed on the date of installation and mailed promptly to the Manitowoc Equipment Works, Manitowoc, Wisconsin.

DEALER _____

INSTALLATION DATE _____

MANITOWOC EQUIPMENT WORKS
Div. of THE MANITOWOC COMPANY
500 South 16th Street
Manitowoc, Wisconsin 54220