

Manitowoc[®] **ICE MACHINES**

Series
B200/B450/B600/B800/B1000

OWNER / OPERATOR USE AND CARE GUIDE

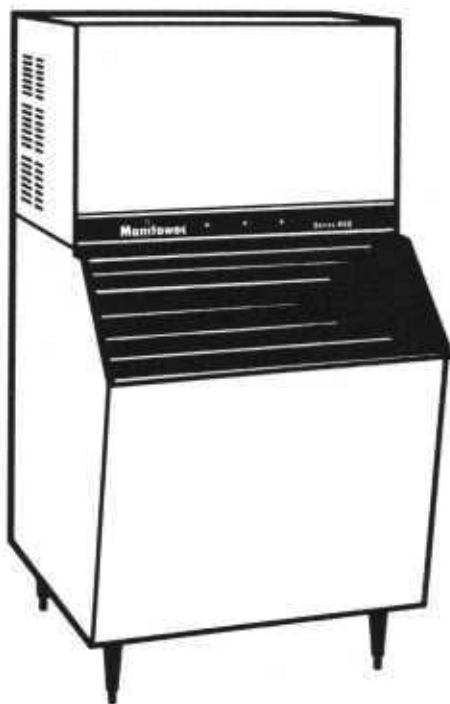

Thank you for selecting a Manitowoc Ice Machine, the dependability leader in ice making equipment and related products. With proper care and maintenance, your new Manitowoc Ice Machine will provide you with many years of reliable and economic performance.

We reserve the right to make product improvements at any time. Specifications and design are subject to change without notice.



Part No. 80-0886-3
Rev 2 8-94

IMPORTANT

Proper installation is essential for maximum ice production and trouble-free operation of your Manitowoc Ice Machine.

Read and understand these Installation Instructions **before proceeding**. Installation corrections are not covered by the warranty.

If you encounter problems not covered by this guide, feel free to contact Manitowoc Equipment Works. We will be happy to provide whatever assistance you may need.

These Installation Instructions cover the following model numbers:

<u>Self-Contained Air-Cooled</u>	<u>Self-Contained Water-Cooled</u>	<u>Remote Air Cooled</u>
BR0200A	BR0201W	N/A
BD0202A	BD0203W	N/A
BY0204A	BY0205W	N/A
BR0450A	BR0451W	BR0450N
BD0452A	BD0453W	BD0492N
BY0454A	BY0455W	BY0494N
BR0600A	BR0601W	BR0690N
BD0603A	BD0603W	BD0692N
BY0604A	BY0605W	BY0694N
BR0800A	BR0801W	BR0890N
BD0802A	BD0803W	BD0892N
BY0804A	BY0805W	BY0894N
BR1000A	BR1001W	BR1090N
BD1002A	BD1003W	BD1092N
BY1004A	BY1005W	BY1094N

(For stainless steel exterior, add an "S" suffix to the model number – example: BY0804AS)

CONTACT YOUR MANITOWOC DEALER FOR THESE OPTIONAL ACCESSORIES:

BIN CASTER - Replaces standard legs.

DECORATOR FRONT COVER - Ebony black or ivory blend textured front panels for the machine (or dispensers) enhance style and beauty. (All models are also available with optional stainless steel cover and side exteriors.)

STACKING KITS - As your business grows and your ice needs increase, Manitowoc stack-on capability can double your daily ice production without using additional space.

ICE BAGGER - Maximize profits from bagged ice sales with this convenient accessory. This sturdy unit rests on the bin door frame, and adapts for left or right side filling.

TRI-LIMINATOR WATER FILTER SYSTEM - Engineered specifically for Manitowoc Ice Machines, Tri-Liminator water filters are an efficient, dependable, and affordable method of inhibiting scale formation, filtering sediment and removing chlorine taste and odor.

MANITOWOC CLEANER/SANITIZER - Manitowoc Ice Machine Cleaner and Sanitizer is available in convenient 16 oz. bottles. (The only approved cleaner and sanitizer compatible for use with Manitowoc products.)

DISPENSERS - Countertop dispensers are ideal for cafeterias and many types of self-service facilities. (Cold plate dispensers are also available.) Manitowoc auto-fill, floor-standing ice dispensers meet the strict sanitary requirements of the foodservice, lodging and healthcare industries.

AUTOMATIC CLEANING SYSTEM (AuCS™) ACCESSORY - This accessory virtually eliminates equipment cleaning maintenance expense. The AuCS™ accessory monitors ice making cycles and initiates self cleaning procedures automatically. (Refer to page 16 of these instructions.)

TABLE OF CONTENTS

SECTION 1 — GENERAL INFORMATION

Model/Serial Numbers Location 5
 Owner Warranty Registration Card 6
 Warranty Coverage 6

SECTION 2 — ABOUT YOUR ICE MACHINE

Component Location and Identification 7
 Sequence of Operation 8
 Initial start-up or start-up after automatic shut-off 8
 Freeze Sequence 8
 Harvest Sequence 8
 Automatic Shut-off 8
 Operational Checks 9
 Water Level Check 9
 Ice Thickness Check 9

SECTION 3 — MAINTENANCE

Maintenance Guidelines Chart 10
 General Ice Machine Inspection 10
 Exterior Cleaning 10
 Cleaning the Condenser 11
 Air-Cooled Condenser 11
 Water-Cooled Condenser 11
 Interior Cleaning/Sanitizing – Self Cleaning System (SeCS™) 12
 Cleaning Procedures 12
 Sanitizing Procedures 13
 Automatic Cleaning System (AuCS™) Accessory 13
 Automatic Operation 13
 Manual Start Operation 14
 Automatic Cleaning Mode 14
 Clean (or Sanitize) Cycle 14
 Rinse Cycles 14
 Changing the Switch Position Prior to Completion of the Automatic Cleaning Mode 14
 Removal of Parts for Cleaning/Sanitizing 15
 Water Dump Valve Removal 16
 Removal Procedure 16
 Water Pump 17
 Ice Thickness Probe 17
 Water Trough 17
 Float Valve 17
 Water Distribution Tube 18
 Water Curtain 18
 Water Treatment/Filtration 19
 Replacement Procedure 19
 Removal from Service/Winterization 20

SECTION 4 — BEFORE CALLING FOR SERVICE

Checklist 21

SECTION 1 GENERAL INFORMATION

MODEL/SERIAL NUMBERS LOCATION

Record the model and serial numbers of your ice machine and bin or dispenser in the space provided below. These numbers are required when requesting information from your local Manitowoc distributor, service representative, or Manitowoc Equipment Works.

The model and serial numbers are listed on the OWNER WARRANTY REGISTRATION CARD. They are also listed on the MODEL/SERIAL NUMBERS DECAL affixed to the inside of the ice machine and on the back panel of the bin, Figure 1.

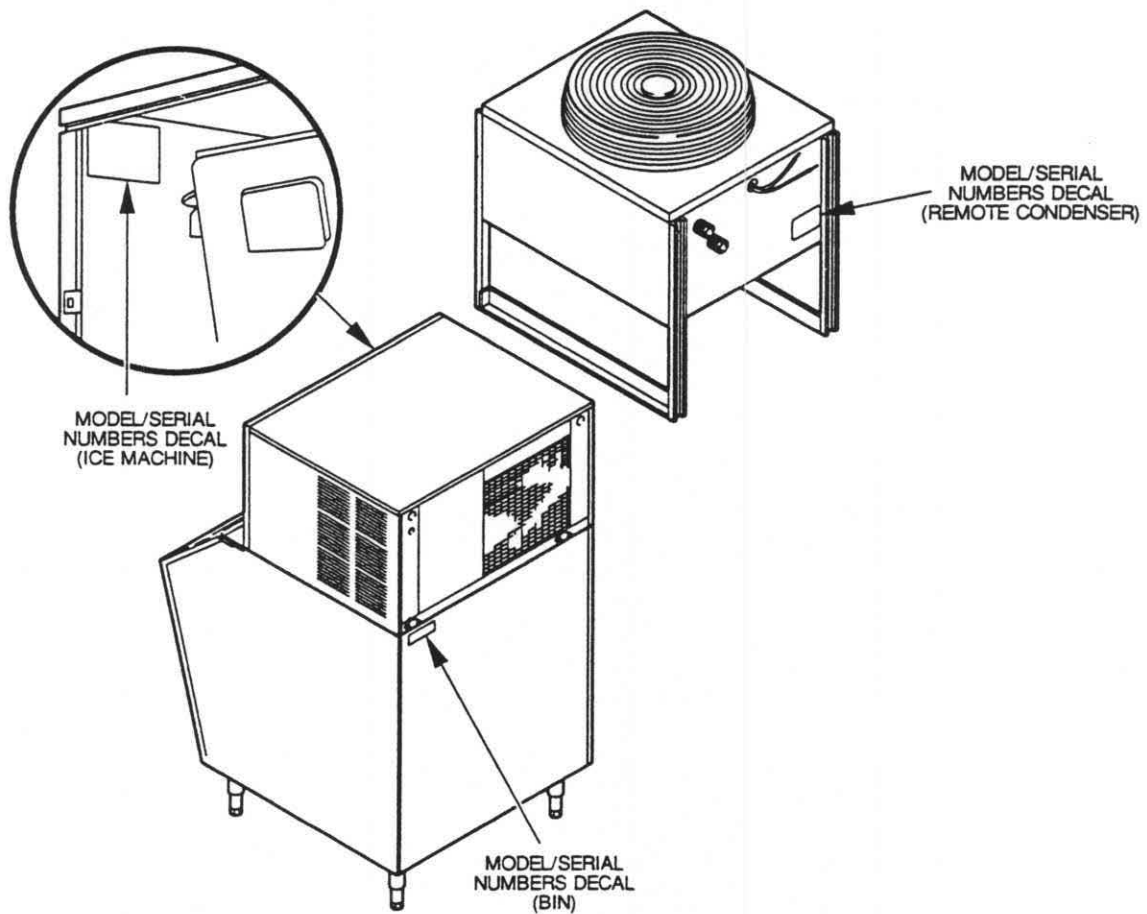

Figure 1. MODEL/SERIAL NUMBER LOCATION

	ICE MACHINE	BIN OR DISPENSER	REMOTE CONDENSER	AuCS™ ACCESSORY
Model Number	_____	_____	_____	_____
Serial Number	_____	_____	_____	_____

**OWNER WARRANTY
REGISTRATION CARD**

The packet containing this guide also includes warranty information. Warranty coverage begins the day your new ice machine is installed.

Important

Complete and mail the OWNER REGISTRATION CARD as soon as possible to validate the installation date.

Manitowoc will use the date of sale to the **Manitowoc Distributor** as the first day of warranty coverage for your new ice machine, if you do not return your OWNER REGISTRATION CARD.

WARRANTY COVERAGE

The following Warranty outline is provided for your convenience. For a detailed explanation, read the warranty bond on the inside back cover of this guide.

Contact your local Manitowoc representative or Manitowoc Equipment Works if you need further warranty information.

Parts

1. Manitowoc warrants the ice machine against defects in materials and workmanship, under normal use and service, for three (3) years from the date of original installation.
2. The evaporator and compressor are covered by an additional two (2) year (**five years total**) warranty beginning on the date of the original installation.

Labor

1. Labor required to repair or replace defective components is covered for three (3) years from the date of original installation.
2. The evaporator is covered by an additional two (2) year (**five years total**) labor warranty beginning on the date of the original installation.

Exclusions from Warranty Coverage

The following items are not included in the ice machine's warranty coverage.

1. Normal maintenance, adjustments and cleaning as outlined in this manual.
2. Repairs due to unauthorized modifications to the ice machine, or the use of nonstandard parts without prior written approval from Manitowoc Equipment Works.
3. Damage caused by improper installation of the ice machine, electrical supply, water supply or drainage, or damage caused by floods, storms, or other acts of God.
4. Premium labor rates due to holidays, overtime, etc.; travel time; flat rate service call charges; mileage and miscellaneous tools and material charges not listed on the payment schedule. Additional labor charges resulting from the inaccessibility of the ice machine are also excluded.
5. Parts or assemblies subjected to misuse, abuse, neglect or accidents.
6. Damage or problems caused by installation, cleaning and/or maintenance procedures inconsistent with the technical instructions provided in the Installation Manual and this Owner/Operator Use and Care Guide.

Authorized Warranty Service

To comply with the provisions of the warranty, a refrigeration service company, qualified and authorized by your Manitowoc distributor, or a Contracted Service Representative must perform the warranty repair.

Note

If the dealer you purchased the ice machine from is **NOT** authorized to perform warranty service, contact your Manitowoc distributor or our Wisconsin headquarters for the name of the nearest authorized service representatives.

Service Calls

If you have followed the procedures listed in this guide (page 21), and the ice machine still does not perform properly, call your authorized service company.

SECTION 2 ABOUT YOUR ICE MACHINE

COMPONENT LOCATION AND IDENTIFICATION

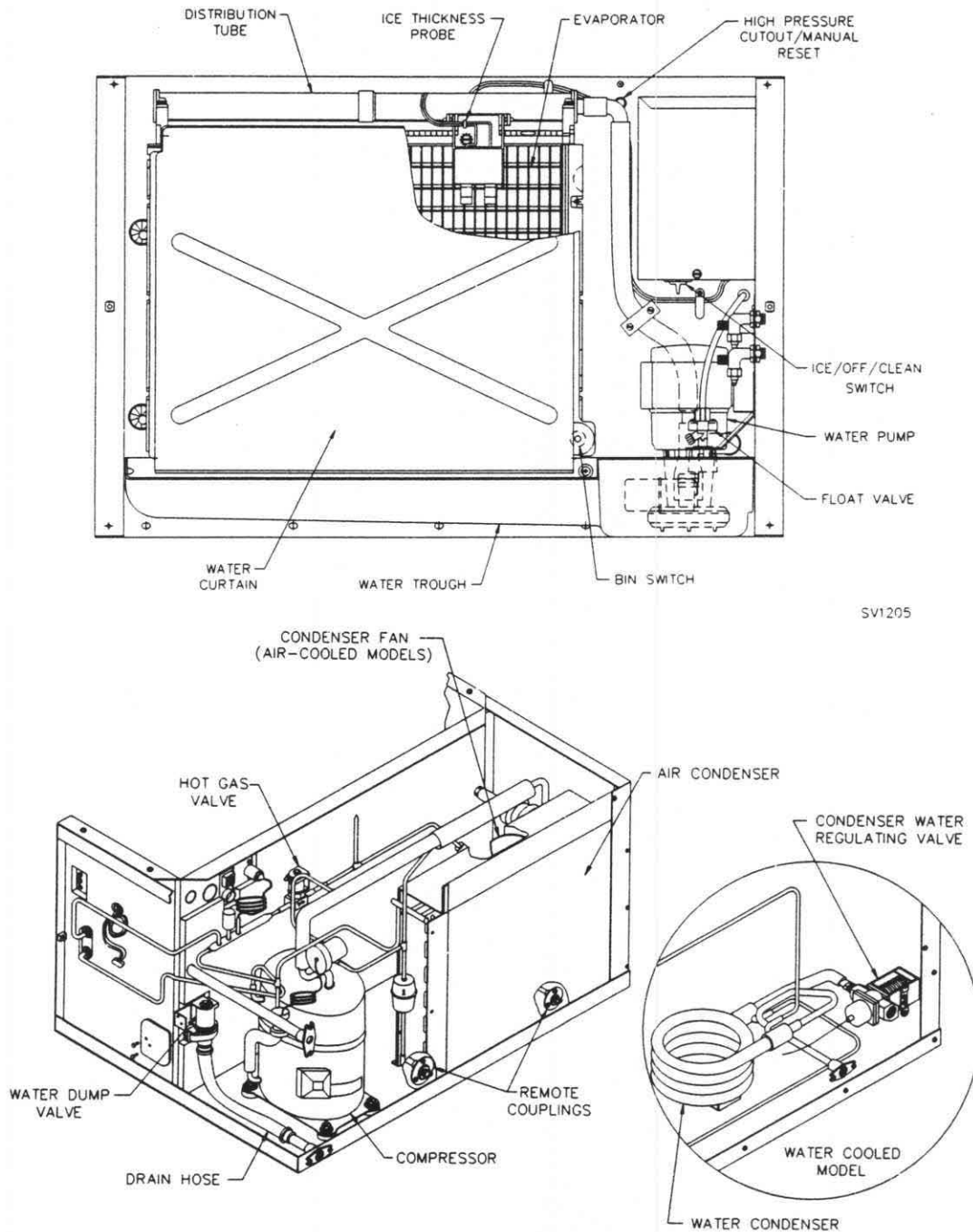

SV1205

SV1206

Figure 2. COMPONENT LOCATION/IDENTIFICATION
(B450 SHOWN)

SEQUENCE OF OPERATION

(B450 Shown)

**INITIAL START-UP OR
START-UP AFTER AUTOMATIC SHUT-OFF**

1. Before the ice machine starts, the water pump and water dump solenoid are energized for 45 seconds to completely purge the sump trough of old water. This feature ensures that the ice making cycle starts with fresh water.
2. The compressor and fan motor (air-cooled/remote models) start after the water pump and water dump valve de-energize.

FREEZE SEQUENCE

3. The water pump restarts after a 30 second delay. When the water pump is running, an even flow of water is directed across the evaporator and into each cube cell, where it freezes.
4. When sufficient ice has formed, the water flow contacts the ice thickness probe. After approximately seven seconds, the harvest sequence is initiated.

HARVEST SEQUENCE

5.
 - a. The hot gas valve opens, diverting hot refrigerant gas into the evaporator.
 - b. The water dump solenoid is energized for 45 seconds to purge the water in the sump trough. After the 45 second purge, the water pump and water dump valve de-energize.
6. The hot refrigerant gas warms the evaporator, causing the cubes to slide, as a unit, off the evaporator and into the storage bin.

The sliding sheet of cubes swings the water curtain out, activating the bin switch. The momentary opening of the bin switch terminates the harvest sequence and returns the ice machine to the freeze sequence (Steps 3-4).

AUTOMATIC SHUT-OFF

7. When the storage bin is full, the sheet of cubes fail to clear the water curtain and hold it open. If the water curtain is held open for more than seven seconds, the ice machine will shut off.
8. The ice machine remains off until enough ice has been removed from the storage bin that the ice can drop clear of the water curtain. As the water curtain swings back to operating position, the ice machine restarts. (Steps 1-2).

SELF CLEANING SYSTEM (SeCS™).

Refer to page 12.

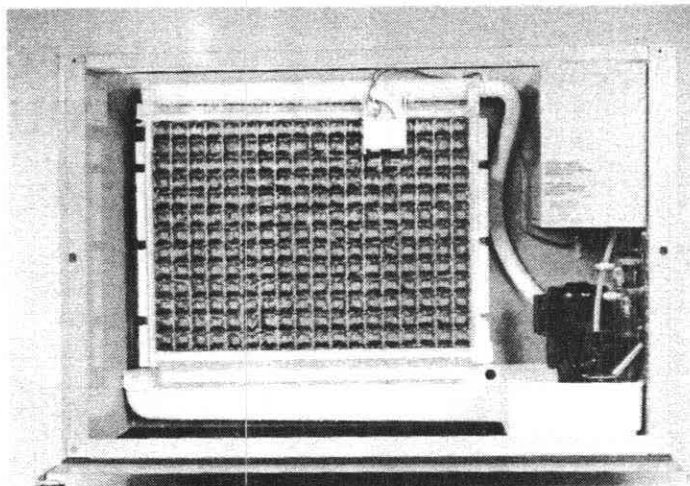

Figure 3. FREEZE SEQUENCE

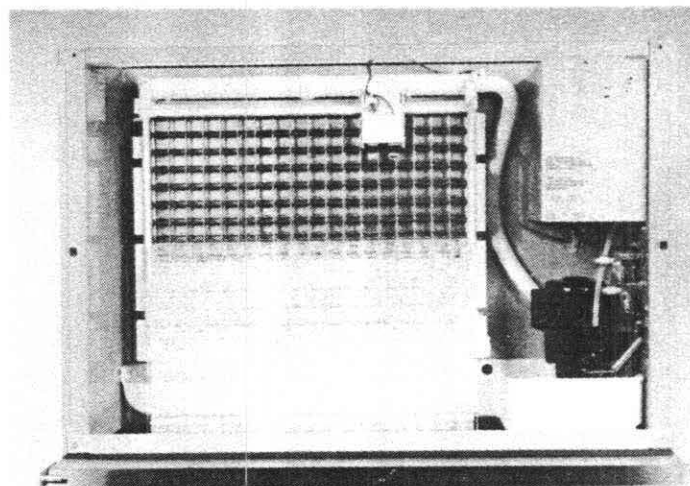

Figure 4. HARVEST SEQUENCE

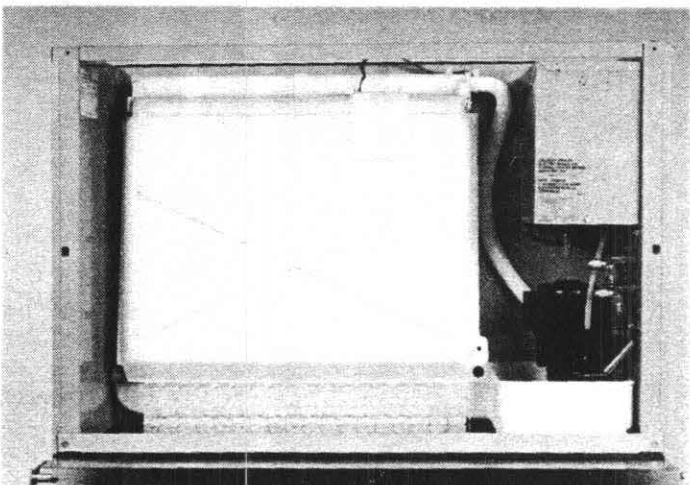

Figure 5. AUTOMATIC SHUTOFF

OPERATIONAL CHECKS

Your Manitowoc ice machine is factory operated and adjusted before shipment. Normally, new installations do not require any adjustment. To ensure proper operation, always follow the Operational Checks when starting the ice machine for the first time, after a prolonged "out of service" period, and after cleaning and sanitizing.

Routine adjustments and maintenance procedures outlined in this guide are not covered by the warranty.

WATER LEVEL CHECK (Figure 6)

1. Check the water level while the machine is in the freeze mode and the water pump is running.

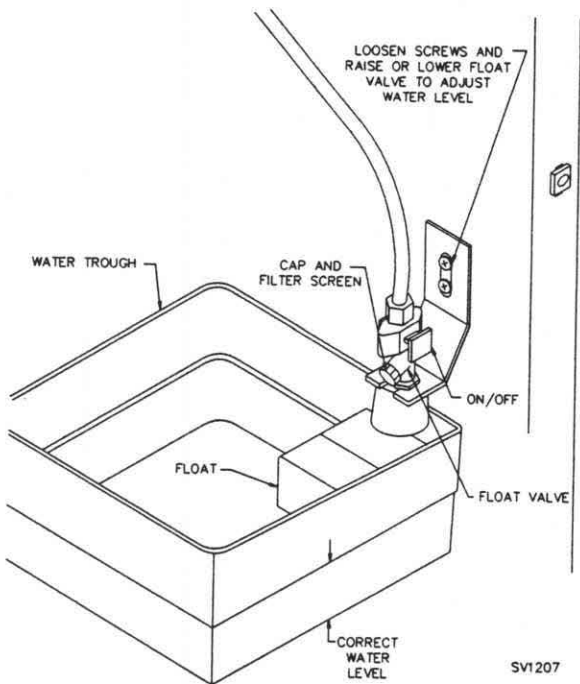

Figure 6. WATER LEVEL CHECK

2. The correct water level is approximately even with the offset in the water trough.

The float valve is factory set for the proper water level. Make the following adjustments if necessary:

- a. Loosen the two screws on the float valve bracket.
- b. Raise or lower the float valve assembly as needed, then re-tighten the screws.
- c. If further adjustment is necessary, carefully bend the float arm to achieve the correct water level.

ICE THICKNESS CHECK (Figure 7)

The ice thickness probe is factory set to maintain the ice bridge thickness at 1/8".

Make sure the water curtain is in place when performing the Ice Thickness Check. The water curtain prevents water from splashing out of the water trough.

Inspect the bridge connecting the cubes. The bridge should be approximately 1/8" thick. Follow the steps below if any adjustment is needed.

1. Turn the ice thickness probe adjustment screw clockwise to increase the bridge thickness or counterclockwise to decrease the bridge thickness.

Note

A 1/3 turn of the adjustment screw changes the ice thickness approximately 1/16".

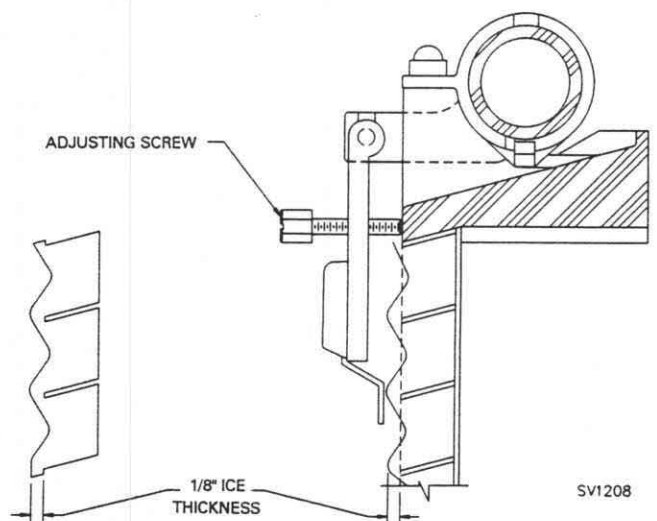

Figure 7. ICE THICKNESS CHECK

2. Make sure that the ice thickness probe wires and bracket do not restrict movement of the probe.

SECTION 3 MAINTENANCE

Follow a general maintenance schedule to ensure reliable, trouble-free operation and maximum ice production.

You are responsible for maintaining the ice machine in accordance with the instructions in this manual. Call your local qualified Manitowoc Service Representative to perform the maintenance if at any time you are either unsure or unaware of the proper procedures and safety

precautions that must be followed.

We recommend that you follow the maintenance guidelines on a semi-annual basis. Record the date you perform the maintenance procedures in the space provided. You can refer to the dates later to remind you to perform the maintenance procedures again.

MAINTENANCE GUIDELINES CHART

SEMI-ANNUAL MAINTENANCE	Page Reference	Dates of Maintenance
1. General Ice Machine Inspection	10	
2. Exterior Cleaning	10	
3. Cleaning the Condenser – Air-Cooled	11	
Water Cooled	11	
4. Interior Cleaning – Self Cleaning System (SeCS™) Cleaning Procedures	12	
Sanitizing Procedures	13	
Removal of Parts for Cleaning/Sanitizing	15	
5. Manitowoc Tri-Liminator water filter system	19	
6. Operational Checks: Water Level	9	
Ice Thickness	9	
7. Winterization	20	

GENERAL ICE MACHINE INSPECTION

Check all water fittings and lines for leaks. Also, make sure the refrigeration tubing is not rubbing or vibrating against other tubing, panels, etc.

Do not stack anything (boxes, etc.) on or around the ice machine. Do not cover the ice machine while it is operating. There must be adequate air flow through and around the ice machine to ensure long component life and maximize ice production.

EXTERIOR CLEANING

1. Clean the area around the ice machine as often as necessary to maintain cleanliness and efficient operation.

2. Sponge any dust and dirt off the outside of the ice machine with mild soap and water. Wipe dry with a soft clean cloth.

⚠ Caution

Stainless steel panels should be cleaned with a mild soap or a commercial stainless steel cleanser. Do not use cleansers containing bleaching agents. They usually contain chlorine which stains stainless steel.

Heavy stains should be removed with stainless steel wool. Never use plain steel wool or abrasive pads. They will scratch the panels and cause rusting.

CLEANING THE CONDENSER

⚠ WARNING
 Disconnect the electric power to the ice machine and the remote condenser at the electric service switch box before cleaning the condenser!

AIR-COOLED CONDENSER (SELF-CONTAINED AND REMOTE MODELS)

A dirty condenser restricts airflow, resulting in excessively high operating temperatures. This reduces ice production and shortens component life. Clean the condenser at least every six months.

⚠ Caution
 The condenser fins are sharp. Use care when cleaning them.

1. The washable aluminum filter is designed to catch dust, dirt, lint, and grease. This helps keep the condenser clean. Clean the filter with a mild soap and water solution.

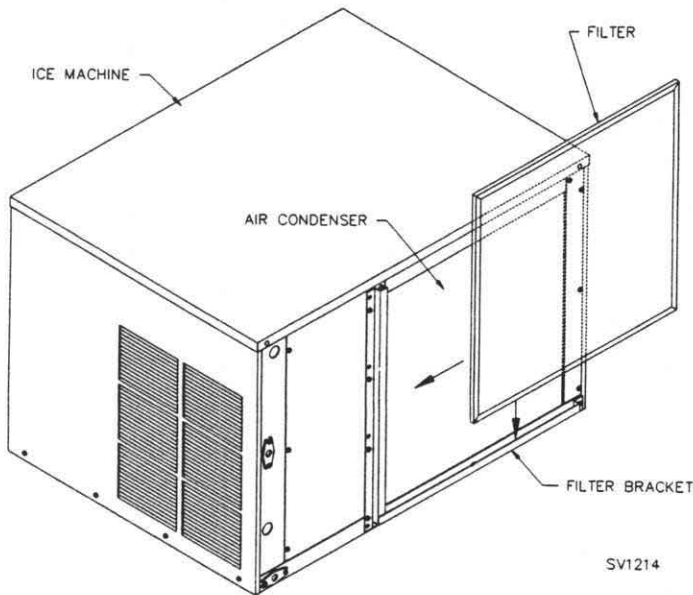

Figure 8. SELF-CONTAINED AIR-COOLED FILTER

2. Clean the outside of the condenser (the bottom side of the remote condenser) with a soft brush or a vacuum with a brush attachment. Brush or wash the condenser from top to bottom – not from side to side. Be careful not to bend the fins. Shine a flashlight through the condenser to check for dirt between the fins.

If further cleaning is required, use one or both of the following procedures:

- a. Blow compressed air through the condenser from the inside. Take care not to bend the fan blades. Shine a flashlight through the condenser to check that all the dirt is removed.
 - b. Clean with a commercial condenser coil cleaner, according to the directions and cautions supplied with the cleaner.
3. Straighten any bent condenser fins with a fin comb, Figure 9.

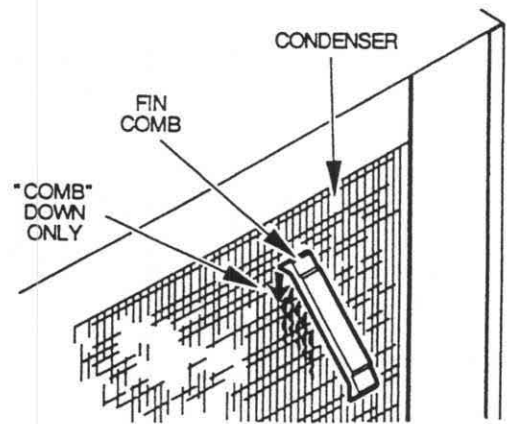

Figure 9. STRAIGHTEN BENT CONDENSER FINS

4. Carefully wipe off the fan blades and motor with a soft cloth, taking care not to bend the fan blades. Wash excessively dirty fan blades with warm soapy water, then rinse thoroughly.

⚠ Caution
 If you are cleaning the condenser fan blades with water, cover the fan motor to prevent water damage.

WATER-COOLED CONDENSER (AND WATER REGULATING VALVE)

The water-cooled condenser and water regulating valve may require cleaning due to scale build-up.

Low ice production, high water consumption and high operating temperatures and pressures all may be symptoms of restrictions in the condenser water circuit.

The cleaning procedures require special pumps and cleaning solutions. Therefore they must be performed by qualified maintenance or service personnel.

INTERIOR CLEANING/SANITIZING— SELF-CLEANING SYSTEM (SeCS™)

Clean and sanitize the ice machine every six months for efficient operation. If the ice machine requires more frequent cleaning and sanitizing, consult a qualified service company to test the water quality and recommend appropriate water treatment or installation of AuCS™ accessory (Automatic Cleaning System).

⚠ WARNING

Use only Manitowoc approved Ice Machine Cleaner (part number 94-0546-3) and Sanitizer (part number 94-0565-3). It is a violation of Federal law to use these solutions in a manner inconsistent with their labeling. Read and understand all labels printed on bottles before use.

CLEANING PROCEDURES

Ice machine cleaner is used to remove lime scale or other mineral deposits. It is not used to remove algae or slime. Refer to the section on Sanitizing for the removal of algae and slime.

⚠ Caution

Do not mix Cleaner and Sanitizer solutions together. It is a violation of Federal law to use these products in a manner inconsistent with their labeling.

⚠ WARNING

Wear rubber gloves and safety goggles (and/or face shield) when handling ice machine cleaner or sanitizer.

Note

If required, extremely dirty ice machines may be taken apart for cleaning or sanitizing. (Refer to page 15.)

1. Set the toggle switch to the OFF position after the ice falls from the evaporator at the end of a Harvest cycle. Or, set the switch to the OFF position and allow the ice to melt off of the evaporator.

⚠ Caution

Never use anything to force ice from the evaporator. Damage may result.

2. To start self-cleaning, place the toggle switch in the CLEAN position. The water will flow through the water dump valve and down the drain.
3. Wait about one minute or until water starts to flow over the evaporator.
4. Add 2 ounces of Manitowoc Ice Machine Cleaner to the water trough.
5. The ice machine Self-Cleaning System (SeCS™) will automatically time out a ten minute cleaning cycle, followed by six rinse cycles, and then stop. (This cycle lasts approximately 25 minutes.)
6. When the self-cleaning stops, move the switch to the OFF position and proceed to the sanitizing section.

SANITIZING PROCEDURES

Use Sanitizer to remove algae or slime. Do not use it to remove lime scale or other mineral deposits.

⚠ WARNING
Wear rubber gloves and safety goggles (and/or face shield) when handling ice machine cleaner or sanitizer.

⚠ Caution
Do not mix Cleaner and Sanitizer solutions together. It is a violation of Federal law to use these products in a manner inconsistent with their labeling.

Note
If needed, extremely dirty ice machines may be taken apart for cleaning or sanitizing. (Refer to page 15).

The Self Cleaning System (SeCS™) is also used for sanitizing:

1. Set the toggle switch to the OFF position after the ice falls from the evaporator at end of a Harvest cycle. Or, set the switch to the OFF position and allow the ice to melt off of the evaporator.
2. Place the toggle switch in the CLEAN position. The water will flow through the water dump valve and down the drain.
3. Wait about one minute or until water starts to flow over the evaporator.
4. Add three ounces of Manitowoc Ice Machine Sanitizer to the water trough.
5. The ice machine Self Cleaning System (SeCS™) will automatically time out a ten minute sanitizing cycle, followed by six rinse cycles, and then stop. (This lasts approximately 25 minutes.)

Note
If the bin requires sanitizing, remove all the ice and sanitize it with a solution of one ounce of sanitizer to up to four gallons of water.

Rinse all sanitized surfaces with clean water.

6. When the self-cleaning (sanitizing) cycle stops, move the toggle switch to the ICE position.

⚠ WARNING
Wear rubber gloves and safety goggles (and/or face shield) when handling ice machine cleaner or sanitizer.

AUTOMATIC CLEANING SYSTEM (AuCS™) ACCESSORY

This accessory monitors icemaking cycles and initiates self cleaning procedures automatically. The AuCS™ Accessory can be set to automatically clean or sanitize the ice machine every 2, 4 or 12 weeks.

⚠ DANGER ⚠
Refer to the AuCS™ Accessory Installation Instructions and the AuCS™ Accessory Owner/Operator Use and Care Guide for complete details on the installation, operation, maintenance and cautionary statements of this accessory.

1. Automatic Operation

The following occurs when the ice machine switch is in the ice making position:

1. The ice machine unitized ice sensor board counts the number of ice harvest cycles.
2. The AuCS™ Accessory automatically interrupts the ice making mode and starts the automatic cleaning mode when the harvest count equals the "frequency of cleaning" setting of the AuCS™ Accessory.
3. When the automatic cleaning mode is complete (approximately 25 minutes), ice making mode resumes automatically.

Note
The harvest count is reset to zero only after the AuCS™ cycle is completed. It cannot be reset by unplugging the modular wire, changing the switch position, power loss, etc.

Manual Start Operation

Verify that no ice is on the evaporator surface. (Set the ICE/OFF/CLEAN switch to the OFF position after the ice falls from the evaporator at end of a harvest cycle, or set the switch to the OFF position and allow the ice to melt off of the evaporator.)

The following occurs when the switch is moved to the cleaning position:

1. The ice machine runs through one rinse cycle and then into the automatic cleaning mode.
2. The ice machine stops all functions when the automatic cleaning mode is completed. Set the switch to the ice making position to restart.

Note

The harvest counter for automatic operation is reset to zero after the automatic cleaning mode cycle is complete.

SEQUENCE OF OPERATION

The ice machine automatically times out a ten minute clean (or sanitizing) cycle, followed by six rinse cycles. The Automatic Cleaning mode lasts approximately 25 minutes.

Note

Opening or removing the water curtain stops the automatic cleaning mode. Upon reclosing, the automatic cleaning mode resumes from the point at which it stopped.

1. **Clean (or Sanitize) Cycle**
(10 minutes, 45 seconds)
 1. The water pump circulates water over the evaporator for 10 minutes. The cleaner or sanitizer is dispensed from the AuCS™ Accessory for 10-20 seconds at the beginning of the cycle.

Important

Once the cleaner or sanitizer solution is dispensed during the clean cycle, you cannot stop the ice machine from running through all six rinse cycles before starting another ice making mode.

2. The water dump valve energizes for 45 seconds to dump the wash water down the drain.

2. **Rinse Cycles (Step 1 and 2 repeated 6 times)**
(13 minutes, 30 seconds)

1. The water pump circulates water over the evaporator for 90 seconds.
2. The water dump valve energizes to dump the rinse water down the drain for 45 seconds.

3. **Changing Switch Position Prior to Completion of Automatic Cleaning Mode**

1. If the switch is turned off prior to dispensing the cleaner or sanitizer, then switched to:
 - a. Ice Making position, normal ice making begins.
 - b. Clean position, a manual start of automatic cleaning mode begins.
2. If the switch is turned off after the cleaner or sanitizer is dispensed, then switched to:
 - a. Ice Making position, the rinse cycles portion of the automatic cleaning mode begins. The ice machine resumes normal ice making operation when rinsing is complete.

Note

Each time you turn the switch off and back to ice making, the 6 rinse cycles begin again.

- b. Clean position, a manual start of automatic cleaning mode begins.

**REMOVAL OF PARTS FOR
CLEANING/SANITIZING**

1. Turn off the water supply to the ice machine at the water service valve.

⚠ WARNING
Disconnect electric power to the ice machine at the electric switch box before proceeding.

2. Remove the water trough, water curtain, water pump, water distribution tube and ice thickness probe. (Refer to the appropriate sections to remove each part.)

⚠ WARNING
Wear rubber gloves and safety goggles (and/or face shield) when handling ice machine cleaner or sanitizer.

3. Soak the removed parts in a properly mixed solution:

Manitowoc Cleaner – mix 16 ounces of cleaner with one gallon of water.

Manitowoc Sanitizer – mix one ounce of sanitizer with four gallons of water.

Use a soft-bristle brush (DO NOT USE A WIRE BRUSH) or a sponge to clean the parts. Take care not to damage them.

⚠ Caution
Do not mix Cleaner and Sanitizer solutions together. It is a violation of Federal law to use these products in a manner inconsistent with their labeling.

⚠ Caution
Do not immerse the water pump motor in the cleaning or sanitizing solution.

4. Use the cleaning or sanitizing solution and a brush or sponge to clean the top, sides, and bottom evaporator extrusions, the inside of the ice machine panels, and the entire inside of the bin.
5. Thoroughly rinse all of the parts and surfaces with clean water and reinstall the parts.

Note
Incomplete rinsing of the ice bridge thickness probe may leave a residue. This could cause the ice machine to go into the harvest cycle prematurely. For best results, brush or wipe the probe off while rinsing. Thoroughly dry it before replacing it.

6. Turn the water and electrical supply back on.

WATER DUMP VALVE REMOVAL

The water dump valve normally does not require removal for cleaning. Follow the instructions listed below to determine if removal is necessary.

1. Remove the top and right side panels.
2. Set the ICE/OFF/CLEAN switch to ICE.
3. Check the dump valve's clear plastic outlet drain hose (Figure 12), for leakage while the ice machine is in the freeze mode.
4. If the dump valve is leaking, remove, disassemble and clean it.
5. Do not remove the dump valve if it is not leaking. Following the Self Cleaning (SeCS™) procedures (page 12) is adequate.

Removal Procedure

⚠ WARNING

Disconnect the electric power to the ice machine at the electric service switch box.

1. Remove the water dump valve shield from its mounting bracket (if applicable).
2. Lift and slide the coil retainer cap from the top of the coil.
3. Leaving the wires attached, lift the coil assembly off of the valve body (enclosing tube). Note the position of the coil assembly on the valve before removing it. Make sure the coil is in the same position when reassembling the valve.
4. Press the enclosing tube's plastic nut down and rotate it 1/4 turn. Remove the enclosing tube, plunger and plastic gasket from the valve body.

The water dump valve can easily be cleaned at this point, without removing the entire valve body.

You do not need to remove the spring from the plunger when cleaning. If the spring is removed, insert the spring's flared end into the slotted opening in the top of the plunger, until it comes in contact with the plunger spring stop. Do not stretch or damage the spring when cleaning.

Important

The plunger and the inside of enclosing tube must be thoroughly dry before reassembling.

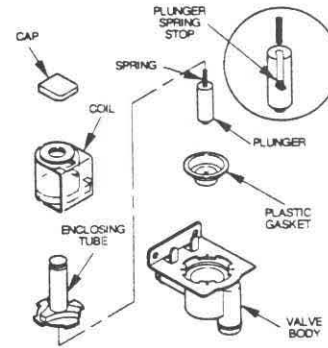

Figure 10. DUMP VALVE DISASSEMBLY

5. Remove the valve body.
 - a. Remove the tubing from the dump valve by twisting the clamps off.
 - b. Remove the two screws securing the dump valve and the mounting bracket.

⚠ WARNING

Disconnect the electrical power to the ice machine at the electrical switch box and turn off the water supply before proceeding.

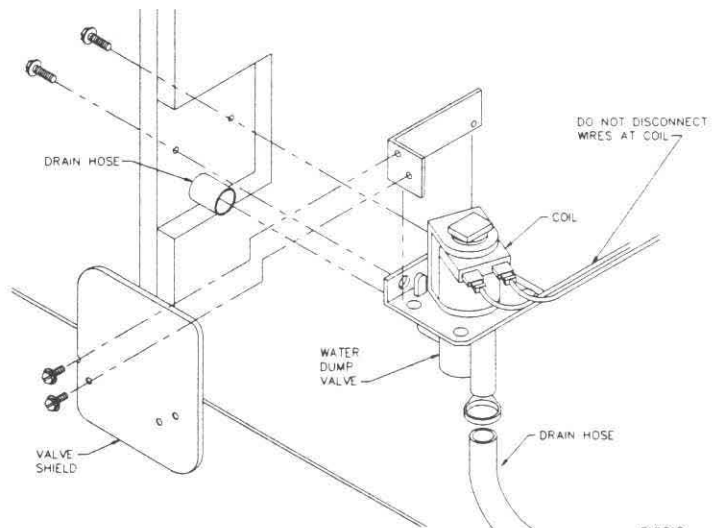

Figure 11. DUMP VALVE REMOVAL

Water Pump

1. Disconnect the water pump power cord.

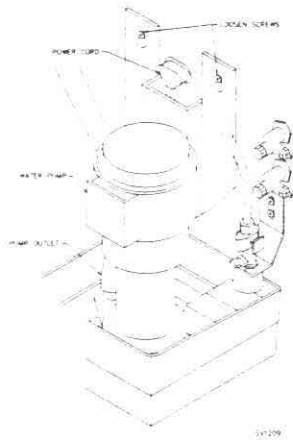

Figure 12. WATER PUMP REMOVAL

2. Disconnect the hose from the pump outlet.
3. Loosen the two screws which hold the pump mounting bracket to the bulkhead.
4. Lift the pump and bracket assembly off screws.

Ice Thickness Probe

1. Remove the ice thickness probe by compressing the side of the probe near the top hinge pin and removing it from the bracket. NOTE: The ice thickness probe can easily be cleaned at this point without proceeding to Step 2.

⚠ WARNING
Disconnect the electric power to ice machine at the electric service switch box before proceeding.

2. If complete removal is required, disconnect the wire leads from the unitized sensor board inside the electrical control box.

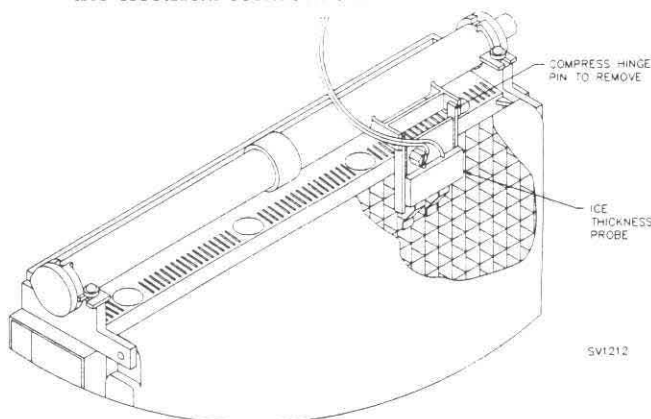

Figure 13. ICE THICKNESS PROBE REMOVAL

Water Trough

1. Remove the screws holding the sump trough in place.
2. Lower the right side of the trough into the bin.
3. Disengage the left side of the trough from its holding pegs and remove the trough from the ice machine.

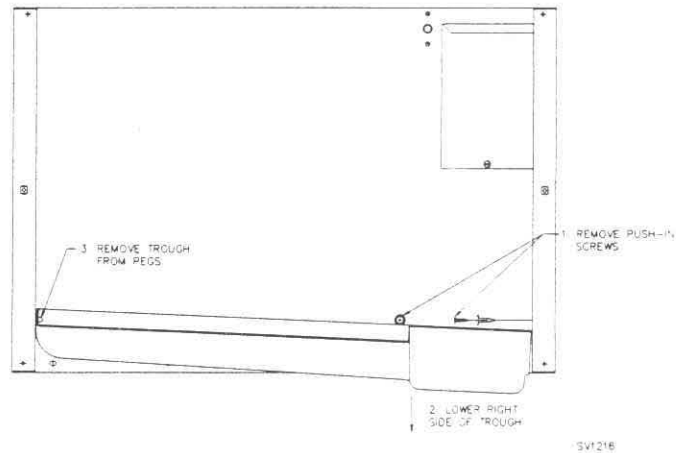

Figure 14. WATER TROUGH REMOVAL

Float Valve

1. Turn the valve splash shield counter-clockwise one or two turns. Pull the valve forward, off the mounting bracket.
2. Disconnect the water inlet tube from the float valve at the compression fitting.
3. Remove the filter screen and cap for cleaning.

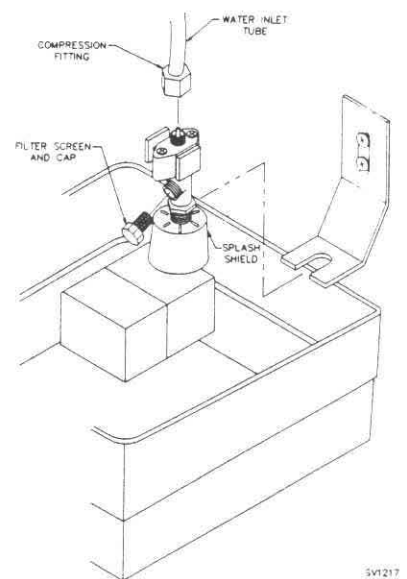

Figure 15. FLOAT VALVE REMOVAL

Water Distribution Tube

1. Disconnect the water hose from the distribution tube.
2. Loosen the two thumbscrews which hold the distribution tube in place.
3. Lift the right side up to clear the locating pin, then slide it back and to the right.

Important
Do not force this removal. Be sure the locating pin clears the hole before sliding it out.

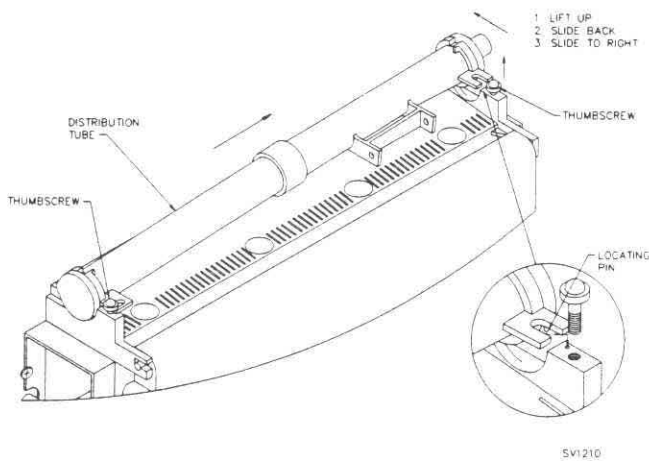

Figure 16. WATER DISTRIBUTION TUBE REMOVAL

4. Disassemble for cleaning.
 - a. Twist both of the inner tube ends until the tabs line up with the keyways.
 - b. Pull the inner tube ends outward.

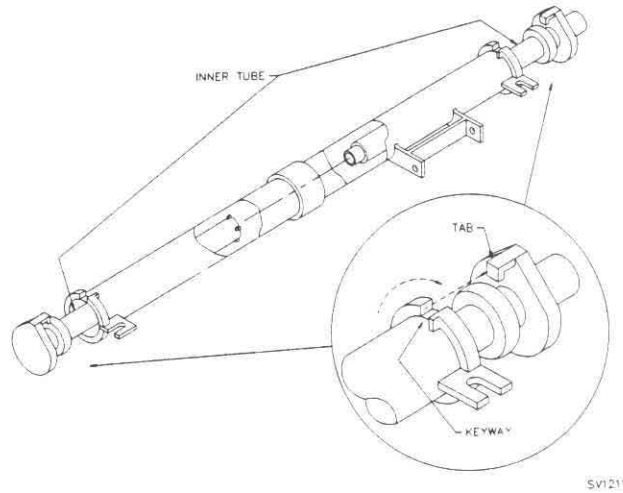

Figure 17. WATER DISTRIBUTION TUBE DISASSEMBLY

Water Curtain

1. Gently flex the curtain in the center and remove it from the right side.
2. Slide the left pin out.

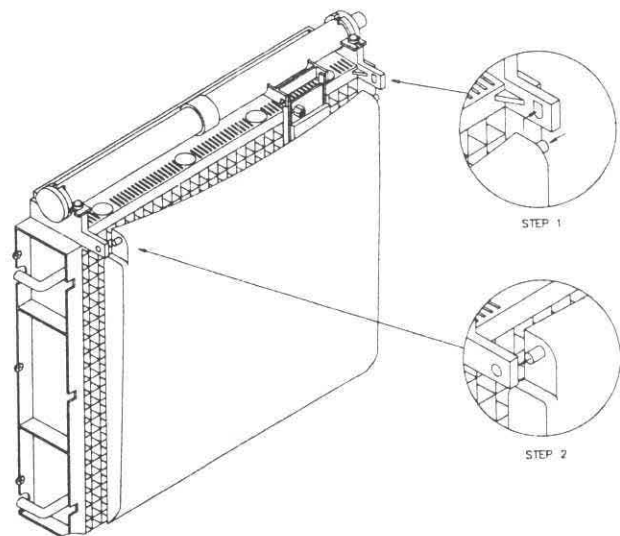

Figure 18. WATER CURTAIN REMOVAL

WATER TREATMENT/FILTRATION

Local water conditions may require the installation of a water treatment system to inhibit scale formation, filter sediment, and remove chlorine taste and odor. Consult your local dealer or distributor for information on Manitowoc's full line of Tri-Liminators filtration systems.

Replace the primary filter cartridge every six months to ensure maximum filtration efficiency. The filter gauge indicates if earlier replacement is necessary (a reading below 20 psig).

Tri-Liminators systems include a prefilter, and should not require primary filter replacement prior to six months of usage. If replacement is needed, replace the prefilter first.

REPLACEMENT PROCEDURE (Figure 19)

1. Turn off the water supply at the inlet shut-off valve.
2. Depress the pressure release button to relieve the pressure.
3. Unscrew the housing from the cap (see illustration).
4. Remove the used cartridge from the housing and discard it.

6. Insert a new cartridge into the housing. Make sure it slips down over the housing standpipe.
7. Screw the housing onto the cap and **hand tighten. Do not over-tighten or use a spanner wrench.**
8. Repeat steps 3 through 7 for each filter housing.
9. Turn on the water supply to allow the housing (and filter) to slowly fill with water.
10. Depress the pressure release button to release trapped air from the housing. Check for leaks.

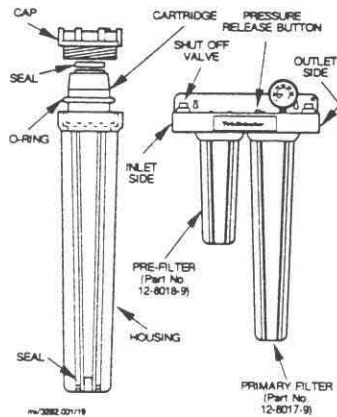

Figure 19. WATER FILTRATION

5. Remove the O-ring from the groove in the housing. Wipe the groove and O-ring clean. Relubricate the O-ring with a coating of clean petroleum jelly (Vaseline). Replace the O-ring, and press it down into the groove with two fingers.

REMOVAL FROM SERVICE/WINTERIZATION

You must take special precautions if the ice machine is to be removed from service for extended periods, or exposed to ambient temperatures of 32°F or below.

⚠ Caution

If water is allowed to remain in the ice machine in freezing temperatures, severe damage to some components could result. Damage of this nature is not covered by the warranty.

Self-Contained Air-Cooled Machines

1. Disconnect the electric power at the circuit breaker or the electric service switch.
2. Turn off the water going to the ice machine.
3. Remove the water from the sump trough.
4. Disconnect the incoming ice making water line, and drain the line at the rear of ice machine.
5. Blow compressed air in both the incoming water and drain openings (in the rear of the machine) until no more water comes out of the float valve and drain.
6. Be sure no water is trapped in any of the machine's water lines, drain lines, distribution tubes, etc.

Water-Cooled Machines

1. Perform all the procedures listed under "Self-Contained Air-Cooled Machines" above.
2. Disconnect the incoming water and drain lines from the water-cooled condenser.
3. Pry open the water regulating valve by inserting a large standard screwdriver between the bottom spring coils of the valve. Pry the spring upward to open the valve, Figure 20.
4. Hold the valve open and blow compressed air through the condenser until no water remains.

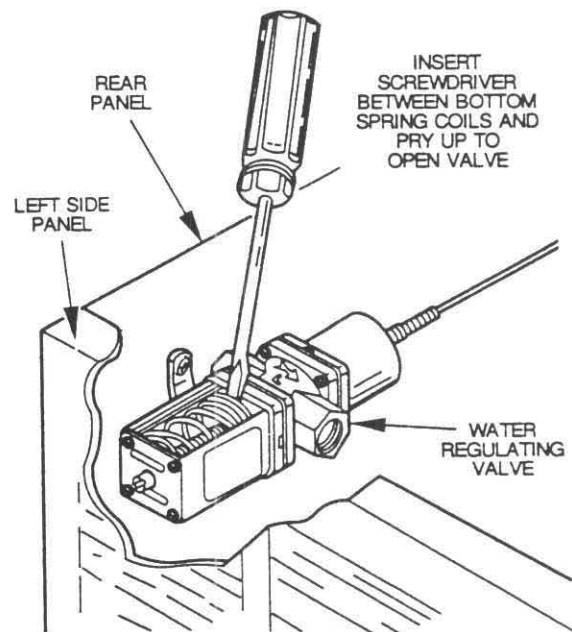

Figure 20. MANUALLY OPEN WATER REGULATING VALVE

Remote Machines

1. Turn the ICE/OFF/CLEAN switch to OFF to allow the ice machine to "pump down" the refrigeration system.
2. Frontseat (shut off) the receiver service valves. (Hang a tag on the switch as a reminder to open the receiver service valves before restarting.)
3. Perform all the procedures listed under "Self-Contained Air-Cooled Machines."

Automatic Cleaning System (AuCS™) Accessory

Refer to the AuCS™ Accessory Installation/Operator Use and Care Guide for winterization of AuCS™ Accessory.

SECTION 4 BEFORE CALLING FOR SERVICE

If a problem arises during the operation of your ice machine, follow the checklist below before calling for service.

CHECKLIST

Problem	Possible Cause	To Correct
Ice machine does not operate.	No electrical power to the ice machine.	Replace the fuse, reset the circuit breaker, turn on the main switch.
	Tripped high pressure cutout.	Reset the high pressure cutout, Figure 2, page 7.
	ICE/OFF/CLEAN switch set improperly.	Set the switch at ICE.
	Water curtain stuck open.	Water curtain must swing freely, Figure 18, page 18.
	Remote receiver valve closed.	Open the valve.
Ice machine stops, and can be restarted by turning the switch off, then on again.	Safety Limit Feature stopping the ice machine.	Refer to the Safety Limit Feature at the end of this checklist.
Ice machine does not release ice or is slow to harvest.	Ice machine is dirty.	Clean and sanitize the ice machine, page 12.
	Ice machine is not level.	Level the ice machine.
	Air-cooled models: low ambient temperature.	Minimum ambient temperature is 35°F.
	Water regulating valve is leaking during the harvest mode (water-cooled ice machines).	Refer to the Water-Cooled Condenser section, page 11.
Ice machine does not cycle into harvest mode. NOTE: Ice machine must be in the freeze cycle for six (6) minutes before a harvest cycle can be initiated.	Ice thickness probe is dirty.	Clean and sanitize the ice machine, page 12.
	Ice thickness probe wires are disconnected.	Connect the wires.
	Ice thickness probe is out of adjustment.	Adjust ice thickness probe, Figure 7, page 9.
	Uneven ice fill (thin at top of the evaporator).	Refer to Shallow or Incomplete Cubes, page 22.
Poor quality ice. (Ice soft or not clear.)	Quality of the incoming water is poor.	Contact a qualified service company to test the quality of the water and make appropriate filter recommendations.
	Water filtration element needs to be changed.	Replace the filter.
	Ice machine is dirty.	Clean and sanitize the ice machine, page 12.
	Water dump valve not working.	Disassemble and clean the water dump valve, page 16.
	Water softener working improperly (if installed.)	Repair the water softener.

Problem	Possible Cause	To Correct
Shallow or incomplete cubes, incomplete ice fill pattern on the evaporator.	Ice thickness probe is out of adjustment.	Adjust the ice thickness probe, Figure 7, page 9.
	Water trough level is too high or too low.	Adjust the float valve, Figure 6, page 9.
	Water float valve filter screen is dirty. Ice machine is dirty.	Clean the filter screen, Figure 15, page 17.
	Water filtration is poor.	Replace the filter, Figure 19, page 19.
	Hot incoming water.	Connect the ice machine to a cold water supply. See the Installation Instructions.
	Incorrect incoming water pressure.	Water pressure must be 20-80 psi.
	Leaky water dump valve.	Clean the water dump valve, page 16.
	Ice machine is not level.	Level the ice machine.
Low ice capacity.	Water float valve filter screen dirty.	Clean the filter screen, Figure 15, page 17.
	Float valve shut-off is closed.	Open the shut-off valve, Figure 6, page 9.
	Incoming water supply shut off.	Open the water service valve.
	Float valve stuck open.	Clean and adjust, Figure 15, page 17.
	Dirty condenser.	Clean the condenser (air-cooled, page 11, water-cooled, page 11).
	High ambient temperature.	Maximum ambient temperature is 110°F.
	Inadequate clearance around the ice machine, causing air flow restriction.	Provide adequate clearance.
	Object stacked on or around the ice machine, blocking air flow to the condenser (air-cooled models).	Remove objects.
Air baffle is not installed (air-cooled models).	Install the air baffle. Follow the instructions about the air baffle.	

SAFETY LIMIT FEATURE

In addition to the standard safety controls, such as the high pressure cut-out, your Manitowoc ice machine features built-in safety limits which stop the ice machine if conditions exist that may result in a major component failure.

Before calling for service, restart the ice machine using the following procedures:

1. a. Turn the ICE/OFF/CLEAN switch OFF and then back to ICE. If the safety limit feature has stopped the ice machine, it will restart after a short delay. Proceed to Step 2.
b. If the ice machine does not restart, refer to "Ice Machine Does Not Operate" in the problem checklist.
2. Let the ice machine operate to determine if the condition is recurring.
 - a. If the ice machine stops again, the condition recurred. Call for service.
 - b. If ice machine continues to run, the condition corrected itself. Let the machine run.

ICE MACHINE WARRANTY

Manitowoc Equipment Works, a division of The Manitowoc Company, Inc., hereinafter referred to as the COMPANY, warrants new Ice Machines manufactured by the COMPANY to be free from defects in material and workmanship under normal use and service for a period of thirty-six (36) months from the date of original installation, and twenty-four (24) additional months on the evaporators and compressors. The obligation of the COMPANY under this warranty is limited to the repair or replacement of parts or assemblies that in the COMPANY'S opinion are defective F.O.B. the factory.

In addition to the component warranty explained above, the COMPANY will pay straight time labor to repair or replace a defective component when failure occurs within thirty-six (36) months from the date of original installation and twenty-four (24) additional months on evaporator and only when such service is performed by a COMPANY Contracted Service Representative or a refrigeration service agency as qualified and authorized by the COMPANY'S local Distributor.

Time and hourly rate schedules as published from time to time by the COMPANY, apply to all service procedures. Additional expense including, but not limited to, overtime premium, travel time, material cost, accessing or removal of the ice machine, is the responsibility of the owner along with all maintenance, adjustments, cleaning and ice purchases.

The foregoing warranty shall not apply to (1) any part or assembly that has been altered, modified, or changed; (2) any part or assembly that has been subject to misuse, abuse, neglect, or accidents; or (3) any ice machine that has been installed and/or maintained inconsistent with the technical instructions provided by the COMPANY.

The sixty (60) month compressor warranty, including the thirty-six (36) month labor replacement warranty, shall not apply when the Ice Machine's refrigeration system is modified with a condenser, heat reclaim device, or parts and assemblies other than those manufactured by the COMPANY, unless the COMPANY approves these modifications for specific locations in writing.

THIS WARRANTY IS IN LIEU OF ALL OTHER WARRANTIES OR GUARANTEES OF ANY KIND, EXPRESSED OR IMPLIED, INCLUDING ANY IMPLIED WARRANTY OF MERCHANTABILITY OR FITNESS FOR A PARTICULAR PURPOSE EXCEPT AS PROVIDED IN THIS WARRANTY WITH RESPECT TO DEFECTS IN MATERIAL AND WORKMANSHIP. This liability of the COMPANY arising out of the sale, use or operation of the COMPANY'S parts and equipment, whether in warranty, contract negligence or strict liability, including claims for special, indirect or consequential damages, shall not in any event exceed the cost of furnishing a replacement for a defective part of assembly as hereinabove provided. Upon the expiration of the warranty period, as hereinabove provided, any such liability shall terminate. The foregoing warranty shall constitute the sole and exclusive liability of the COMPANY.

To secure prompt and continuing warranty service, the warranty registration card must be completed and sent to the COMPANY within five (5) days from the installation date.

Complete the following and retain for your record:

Distributor/Dealer _____

Model Number/Serial Number _____

Installation Date _____

MANITOWOC EQUIPMENT WORKS

Division of The Manitowoc Company, Inc. 2110 So. 26th St., P.O. Box 1720, Manitowoc, WI 54221-1720

Telephone: 414-682-0161

Form 80-0373 (1/91)

Telex: 297863 MANCO-UR

Telefax: 414-683-7879

Effective January 1, 1991 in the United States, Canada, and international markets served by Manitowoc.

Revised January 2, 1991

MANITOWOC EQUIPMENT WORKS

Division of The Manitowoc Company, Inc.

2110 South 26th Street, P.O. Box 1720, Manitowoc, WI 54221-1720 U.S.A.

Telephone 414-682-0161

RCA Telex 297863 MANCO-UR

FAX 414-683-7879