

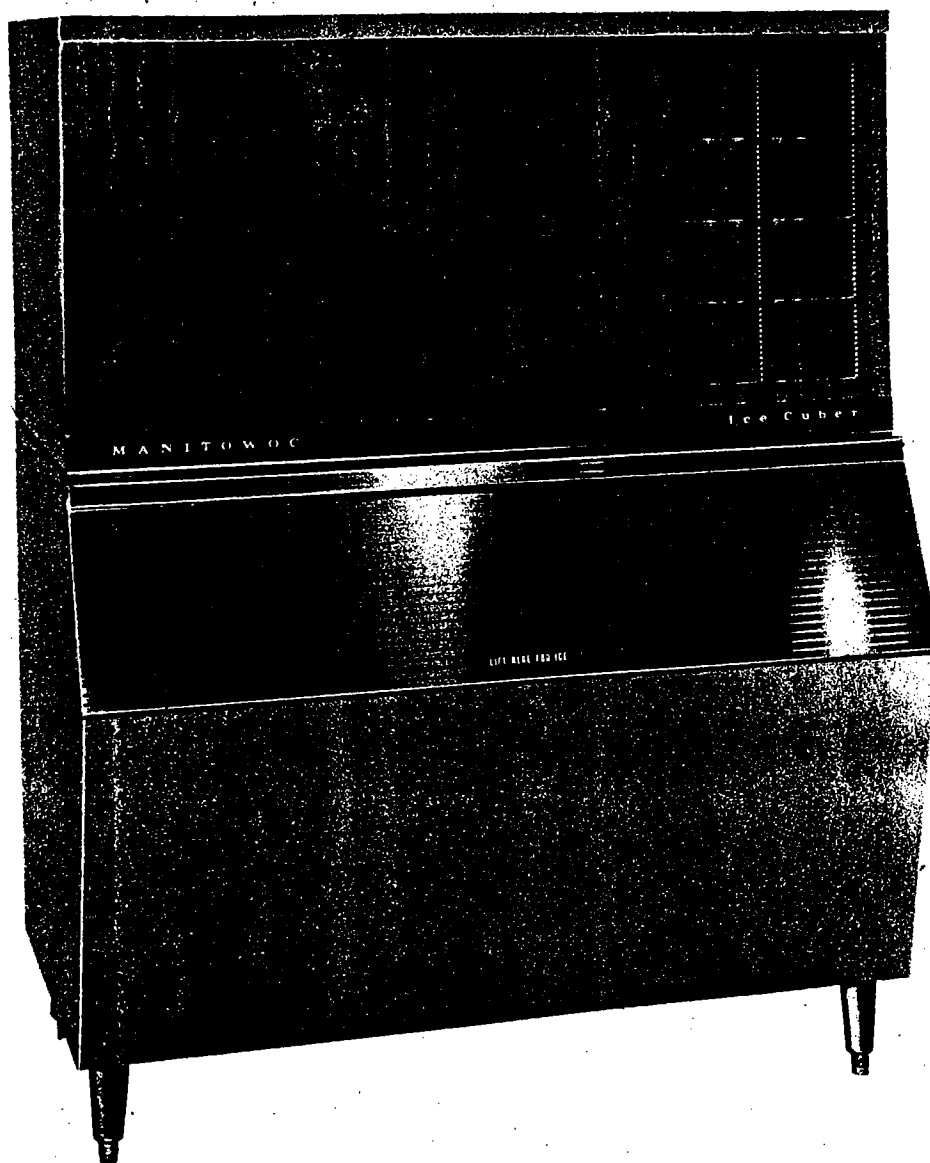

Manitowoc
C-0600 SERIES ICE CUBER
SERVICE MANUAL



Manitowoc equipment works
Division of The Manitowoc Company, Inc.,

MANITOWOC
WISCONSIN

1-12-80
80-0054-3

TABLE OF CONTENTS

Forward	Page 1
Inspection	Page 2
Uncrating	Page 3
Location	Page 3
Serial & Electrical Plate	Page 3
Removal or Installing Panels	Page 3
Removal of Internal Packing	Page 3
General Requirements	Page 3
Electrical Rating	Page 3
Connecting Power Supply	Page 4
Connecting Water Supply	Page 4
Drain Connections	Page 4
Check List for Starting Machine	Page 4
Final Check List	Page 5
Fig. 1 Cuber Dimensions	Page 5
Fig. 2 Cuber with Panels Removed	Page 6
Fig. 3 Compressor Compartment	Page 7
Fig. 4 Ice Making Section	Page 8
Fig. 5 Ice Making Section with Ice Chute & Curtain Removed	Page 9
Fig. 6 Control Box Assembly	Page 10
Fig. 7 Water Pump Assembly	Page 11
System Control & Sequence of Operation	Page 12
Refrigeration Cycle	Pages 12-13
Operating Characteristics	Page 13
Wiring Diagram for C-0600	Page 14
Schematic-Refrigeration Cycle	Page 15
Specifications	Page 16
Component Check-Out Procedure	Pages 17-18
Control Description & Check-Out Procedure	Pages 19-22
C-0690N Cuber with AC-0695A Remote Condenser	Page 23
General Information, C-0600 Remote	Page 23
Installation, C-0600 Remote	Pages 23-24
Fig. 8 Electrical Hook Up	Page 24
Fig. 9 Installation Illustration, C-0600 Remote	Page 25
Start-Up Procedure	Page 26
System Control & Sequence of Operation, C-0600 Remote	Pages 26-28
Wiring Diagram for C-0690N	Page 29
Refrigeration Cycle for C-0690N	Page 30
Fig. 10 Refrigeration Schematic	Page 31
Fig. 11 C-0690N Remote Cuber Compressor Comp.	Page 32
Service Analysis	Pages 33-35
Cleaning Instructions	Page 35
Ordering Parts	Page 36
Serial Number Nomenclature	Page 37
Warranty	Page 38

FORWARD

Manitowoc Equipment Works, Division of The Manitowoc Company, Inc., Manitowoc, Wisconsin, presents this Service Manual to assist the service man with information concerning CONSTRUCTION, INSTALLATION, and MAINTENANCE of the MANITOWOC ICE MAKER.

The problems of the user and the service man have been given special emphasis in the development of the latest MANITOWOC Ice Machines.

If you encounter a problem which is not answered by this manual, please feel free to write or call the Service Department of the Manitowoc Equipment Works, Division of The Manitowoc Company, Inc., Manitowoc, Wisconsin, describing the problem you have encountered. The Service Department will be happy to give you particularized advice and assistance. Whenever calling or writing, please state the complete model and serial number of the ice making equipment.

MANITOWOC EQUIPMENT WORKS
 Div. of THE MANITOWOC CO., INC.
 2110 South 26th Street
 Manitowoc, Wisconsin 54220
 (414) 682-0161

CUBER MODELS

CR-0600A	CD-0602A	CY-0604A	CY-0614AS
CR-0600AS	CD-0602AS	CY-0604AS	CY-0615WS
CR-0601W	CD-0603W	CY-0605W	
CR-0601WS	CD-0603WS	CY-0605WS	
CR-0690N	CD-0692N	CY-0694N	
	Remote Condenser — AC-0695A		

WARRANTY

Parts and Material	One year — parts only
Compressor	Five years — parts only

See page 36 for returning of In Warranty Parts.

(See "Ice Machine and Bin Warranty" page 38 and registration card shipped with the unit for warranty conditions.)

FOR YOUR PROTECTION**INSPECTION**

The carrier who delivers this merchandise to your door is responsible for loss and damages. Acceptance of this shipment by the transportation company is acknowledgment that the articles delivered to them were in good condition and properly packed. It is your responsibility to file a claim with the carrier if any of the following conditions exist.

A. VISIBLE DAMAGE

1. If cartons appear damaged in any form, please open at once in presence of driver.
2. Have deliveryman note on freight bill the nature and extent of damages.
3. Notify the transportation company's office to inspect the merchandise.
4. File claim for damages at once. In filing a claim with the transportation company, you may elect to:
 - (A) Make a cash adjustment for full value,
 - (B) Arrange to have repairs made, or
 - (C) Replace the merchandise.

B. CONCEALED DAMAGE

1. If damage is noticed when merchandise is unpacked, notify the transportation company's office immediately and ask to have it inspected.
2. Do not destroy packing materials until shipment is inspected.
3. Unless these conditions are met, it is very difficult to file a claim against a transportation company.

C. SHORTAGES

1. Check number of cartons delivered with the quantity shown on your receipt.
2. If quantities do not tally, have driver note shortage and file your claim with them.

IMPORTANT

All claims for loss and damage should be filed immediately with the transportation company making delivery to your door.

We are willing to assist you in every possible manner in collecting claims for loss or damage on this shipment, but this willingness on our part does not make us responsible for filling or collecting claims, or replacing merchandise.

Under no circumstances will we accept the return of any merchandise unless written permission has been given by us.

NOTE: See C0600 remote section for additional installation information. (Page 23.)

UNCRATING

The C-0600 Series cuber is shipped separate from the storage bin, in a corrugated carton. Remove the staples around the lower edge of the carton. Lift the carton upwards and off. The shipping skid is mounted to the cuber with 4 bolts located on the underside of the skid. Remove the bolts and set the cuber on the storage bin.

LOCATION

For maximum efficiency, pick a location away from sources of heat like radiators, ovens, other refrigeration condensing units, direct sunlight, etc. Provide a minimum of 5 inches around the cuber for proper air circulation through the compressor compartment. For air cooled models, louvered openings should be 5 inches from the nearest obstruction for best operation. Reduction of clearance may result in increased heat load and reduced ice capacity. A self-contained air cooled cuber will operate more efficient in a room of 70° F. than in a room of 90° F. Recommended minimum room temperature is 55° F. for self-contained air cooled models. If cuber is located in an unheated area, it must be protected from freezing or shut down and drained, see low ambient operation.

LOW AMBIENT OPERATION AND WINTER SHUTDOWN

If the ambient temperature is below 55° F. for a self-contained air cooled C-0600, a low ambient kit, Fancycling switch, P/N 89-5009-9, should be installed. This is not required on water cooled and remote models.

All Manitowoc cuber models must be protected from freezing temperatures or be shutdown and the water lines drained. This includes blowing out the ice water supply lines and drains and the water cooled condenser. To blow the water out of the water cooled condenser the waterlines flare fittings must be removed from the water regulating valve. The water lines and the condenser can now be blown out. See Fig.6 Item 9.

SERIAL & ELECTRICAL PLATE (Fig. 2)

The combined serial and electrical plate is located inside the cuber above the water pump. Be sure to give the complete model number and serial number when calling for service or ordering parts.

REMOVAL OR INSTALLING FRONT PANEL

Caution: when removing front panel mounting screws, hold panel in place until both screws are removed. Secure panel with both hands and lift up slightly and out. To install front panel with cover on, slide the top of front panel under the lip of the cover and set in place. Replace the two screws to secure panel.

REMOVING TOP COVER & COMPRESSOR COMPARTMENT PANELS

The top cover is held in place with four sheet metal screws, two on each end. The rear grille must be removed before the R.H. end panel can be taken off. The rear grille is held in place with four sheet metal screws. The R.H. end panel is held in place with five screws along the bottom edge; (1) on front flange, (3) on side, (1) on rear flange.

REMOVAL OF INTERNAL PACKING

Remove the following:

- The tape securing the splash curtain, water pump & ice chute.
- Remove the ice chute and the corrugated board from around the chute and the plastic sheet from over the chute. Then replace the ice chute and damper door and secure the chute with the clips and thumb screws provided.
- Remove the packing from under the water pump.
- Remove the wooden wedges from under the compressor.
- The box taped in the evaporator section contains the strainer for the ice making water supply line.

GENERAL REQUIREMENTS

All electrical, water supply, and drain connections must conform to local and national codes.

ELECTRICAL RATING

MODEL SERIES	ELECTRICAL	MINIMUM CIRCUIT AMPACITY	MAXIMUM FUSE SIZE
C-0600A	208/230V-60-1Ph	12.8 amps	20 amps
C-0600A	208/230V-60-1Ph	13.4 amps	20 amps
C-0600W	208/230V-60-1Ph	12.1 amps	20 amps
C-0600W	208/230V-60-1Ph	12.7 amps	20 amps
C-0690N	208/230V-60-1Ph	13.3 amps	20 amps

CONNECTING POWER SUPPLY

1. Use electrical wire rated equal or greater than the minimum ampacity rating given on serial plate.
2. Cuber must be on a separately fused circuit, which does not exceed the maximum fuse size on serial plate.
3. Check supply voltage, limits are 208 - 5% to 230V + 10%
4. A ground screw is provided in the supply box.
5. Connect supply wires to cuber leads L₁ and L₂ located inside electrical supply handbox, in the rear of the compressor compartment. Fig. 3.

WATER SUPPLY

Quality and ice making capacity are affected more by chemistry, temperature, and foreign matter in supply water than any other factor. A survey made of water departments of large cities all over the country made it obvious that external filters or strainers should be installed. Such equipment is very effective in improving ice quality and reducing the frequency of cleaning out the ice making section. Any questions as to the type of water filter or strainers to be used can be answered by your local water treatment company or water department. A minimum water pressure of 25 PSIG is required at the water cooled condenser for water cooled models.

CONNECTING WATER SUPPLY (Fig. 1)

A 1/2" female pipe fitting is provided in the rear panel of the ice cuber. Install the water strainer provided with the cuber. Use a 3/8 OD copper tubing for the ice making water supply, and a minimum of 1/2 OD copper tubing for water condenser supply, on water cooled cubers.

DRAIN CONNECTIONS

It is essential that drain connections be made so waste water cannot back up into the head unit or bin. On water cooled models, a separate drain connection is provided for discharging condenser water (Fig. 1). All connections are labeled. We recommend covering all incoming water and drain lines with a plumbing insulation material to prevent condensation.

We recommend that the bin and cuber drains are not tied together and they are run to an open trapped and vented drain.

If the cuber drain line is tied in directly to the drain, we recommend using a 1/2" I.D. tubing and a stand pipe vented to the atmosphere to prevent water traps.

Drains must be at least 1/2" inside diameter copper tubing or 3/8" piping and have 1 1/2" drop per 5 feet of run. If drains are not close enough to allow drop for proper drainage, or water is to be drained in a stationary sink higher than ice machine drains, use an automatic condensate disposal pump. (Check and follow local plumbing codes.)

Bin Drain — The bin is supplied with 3/4" FPT fitting and a min. 3/4" pipe or 3/4" I.D. copper tubing is recommended for the drain line.

CHECK LIST FOR START-UP

1. Remove all internal packing!
2. Be sure the cuber is level! This is to insure proper water flow in the cuber.
3. Turn the supply water on for the sump and the condenser (if water cooled).
4. Turn the toggle switch Fig. 4 to "water pump", position. This will start the water pump only, pumping water to the water distributor and over the evaporator. Check the position of water distributor to see that it is distributing water properly and evenly over the evaporator. See Fig. 5 for proper distributor

location. Set the float in the sump to maintain a level of 1/4" below the top of the overflow tube, while the cuber is running. Should the float valve require adjustment, bend the float rod carefully until desired water level is achieved.

5. Turn the water pump on and off (at approx. 2 minute intervals) several times to flush clean water through the system, and to observe that the flush water drains properly.
6. Check all the refrigerant lines and conduit to guard against vibrations and possible failure.
7. Check all the water connections for leaks.
8. Bend the water curtain hooks slightly to the outside to secure the water curtain in place. These hooks can be seen in Fig. 4.
9. Replace the panels except for the front panel.
10. To start cuber place the toggle switch in the "ICE" position.

FINAL CHECK LIST AFTER START-UP

1. With the cuber operating, reach in and push the damper door open about 1" to 1 1/2". This should open the damper (bin) door switch which will shut down the entire cuber. The cuber will remain OFF until the damper door is released. If the bin switch needs adjustment, bend the metal arm until proper operation is obtained.
2. Cuber should be checked for several harvests of cubes to see that the cuber functions properly, and that the ice cube bridging between cubes is 1/8" in the center of the ice slab. If the bridging needs adjustment see timer check-out procedure. Page 20.
3. Is there 5" clearance around cuber for proper air circulation?
4. Is the room ambient maintained at a minimum of 55° F during winter months, air cooled cubers? NOTE: A condenser fan motor thermostat is available for operations below 55° F. (This does not protect the cuber from freezing temperatures.)
5. Check water and drain connections for water leaks.
6. Has owner been instructed on how to operate and clean the cuber?
7. Has installation and warranty registration card been filled out? This is for owner protection.

**"600" SERIES CUBER — C-610 BIN
606 ADJUSTABLE LEGS**

FIG. 1

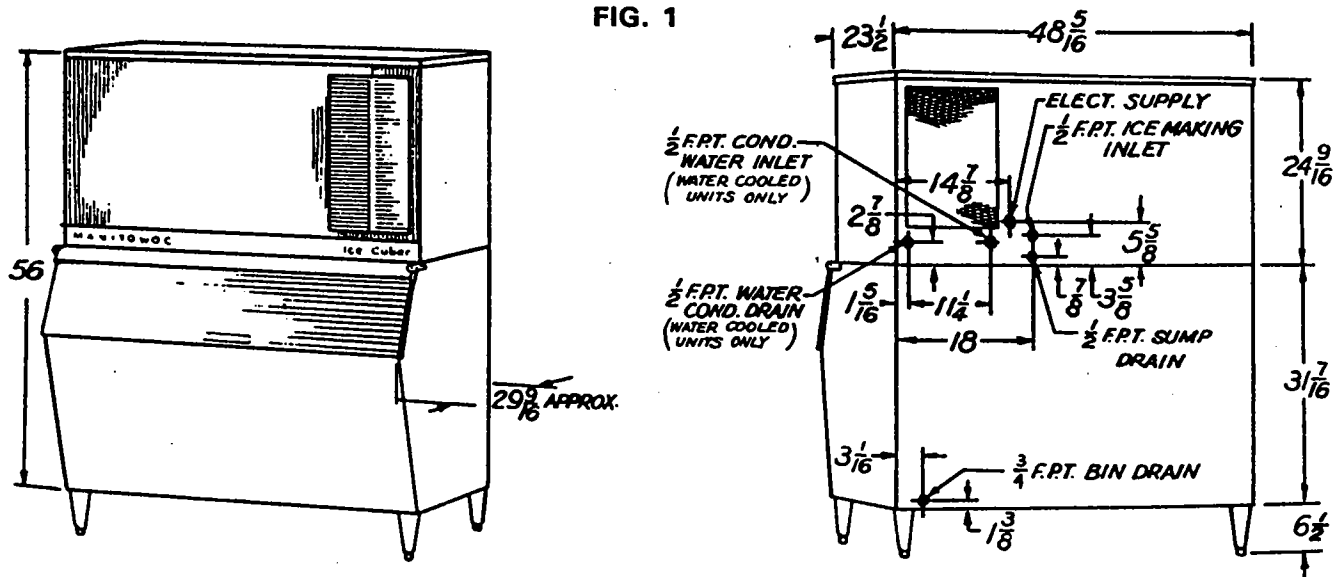

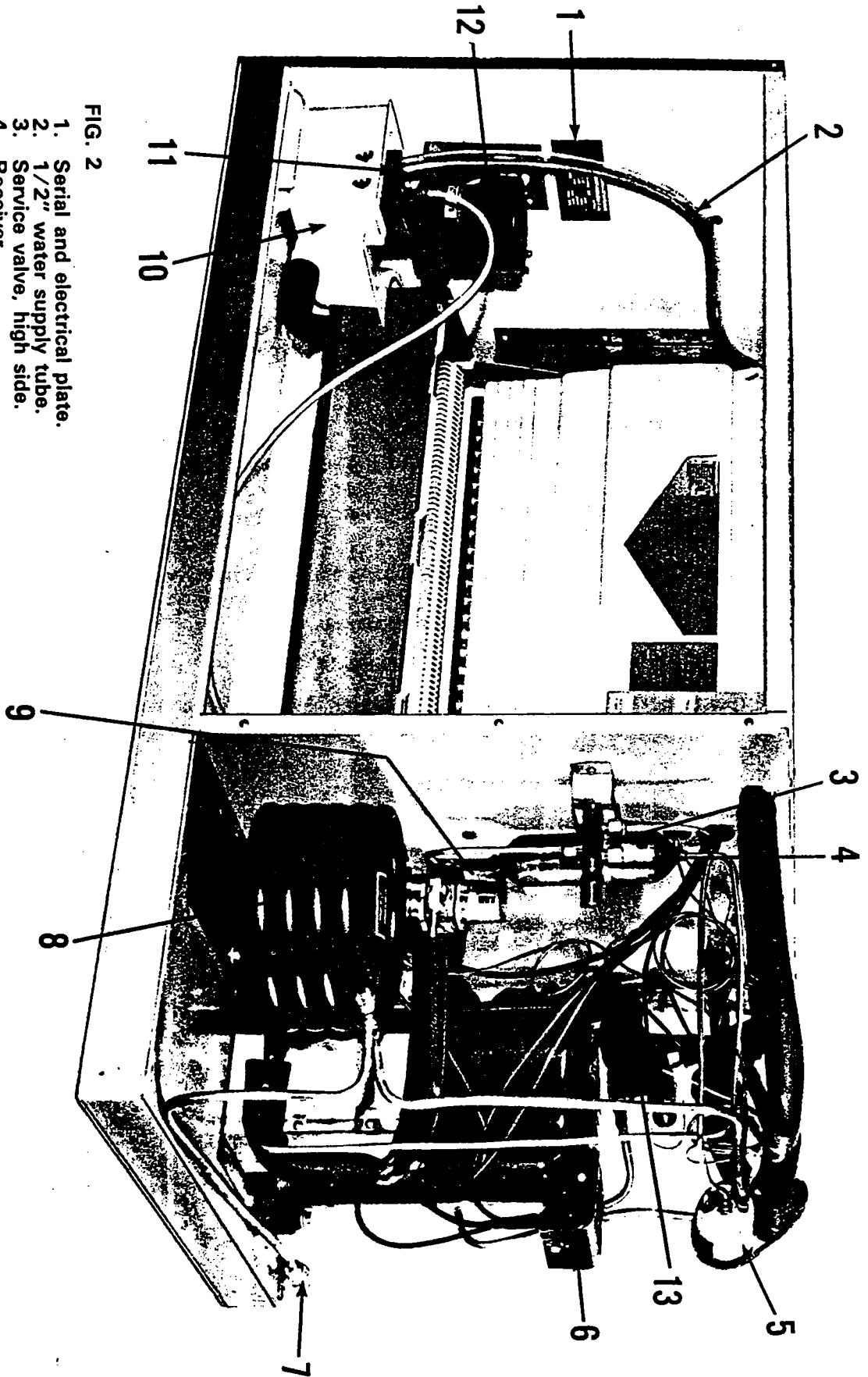

FIG. 2

- 1. Serial and electrical plate.
- 2. 1/2" water supply tube.
- 3. Service valve, high side.
- 4. Receiver.
- 5. Drier.
- 6. Compressor.
- 7. Condenser water drain.
- 8. Water condenser.
- 9. Water regulating valve.
- 10. Water sump trough assembly.
- 11. Float valve assembly.
- 12. Water pump.
- 13. Expansion valve (covered with insulation).

FIG. 2
WATER COOLED C-0600 CUBER WITH PANELS REMOVED

FIG. 3
COMPRESSOR COMPARTMENT AIR COOLED

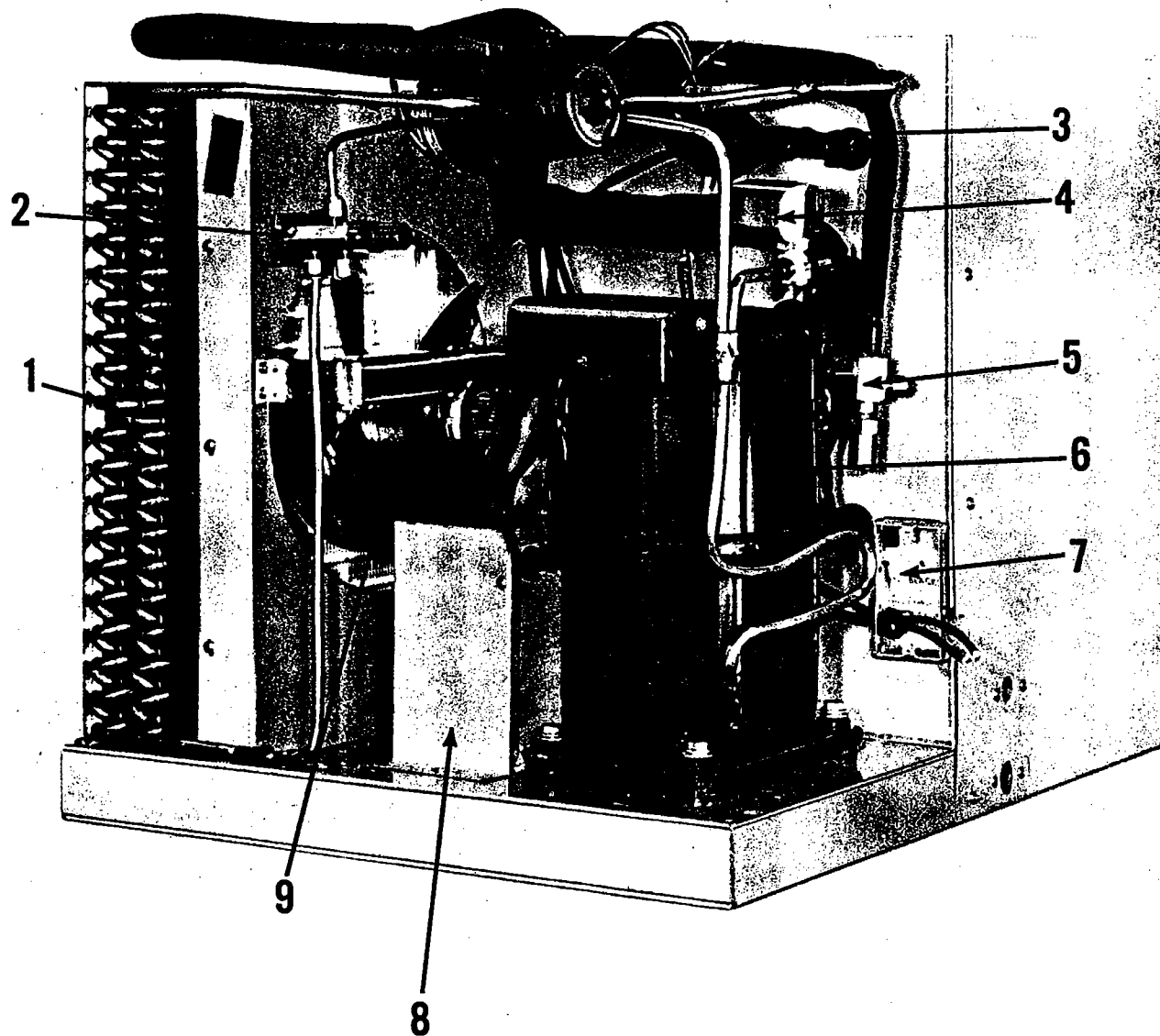

FIG. 3

1. Air condenser assembly.
2. Service valve, high side.
3. Thermodisc (covered with insulation).
4. Hot gas solenoid valve.
5. Suction service valve.
6. Compressor.
7. Electrical supply box and leads.
8. Start relay and capacitor box.
9. Condenser fan motor assembly.

FIG. 4
ICE MAKING SECTION

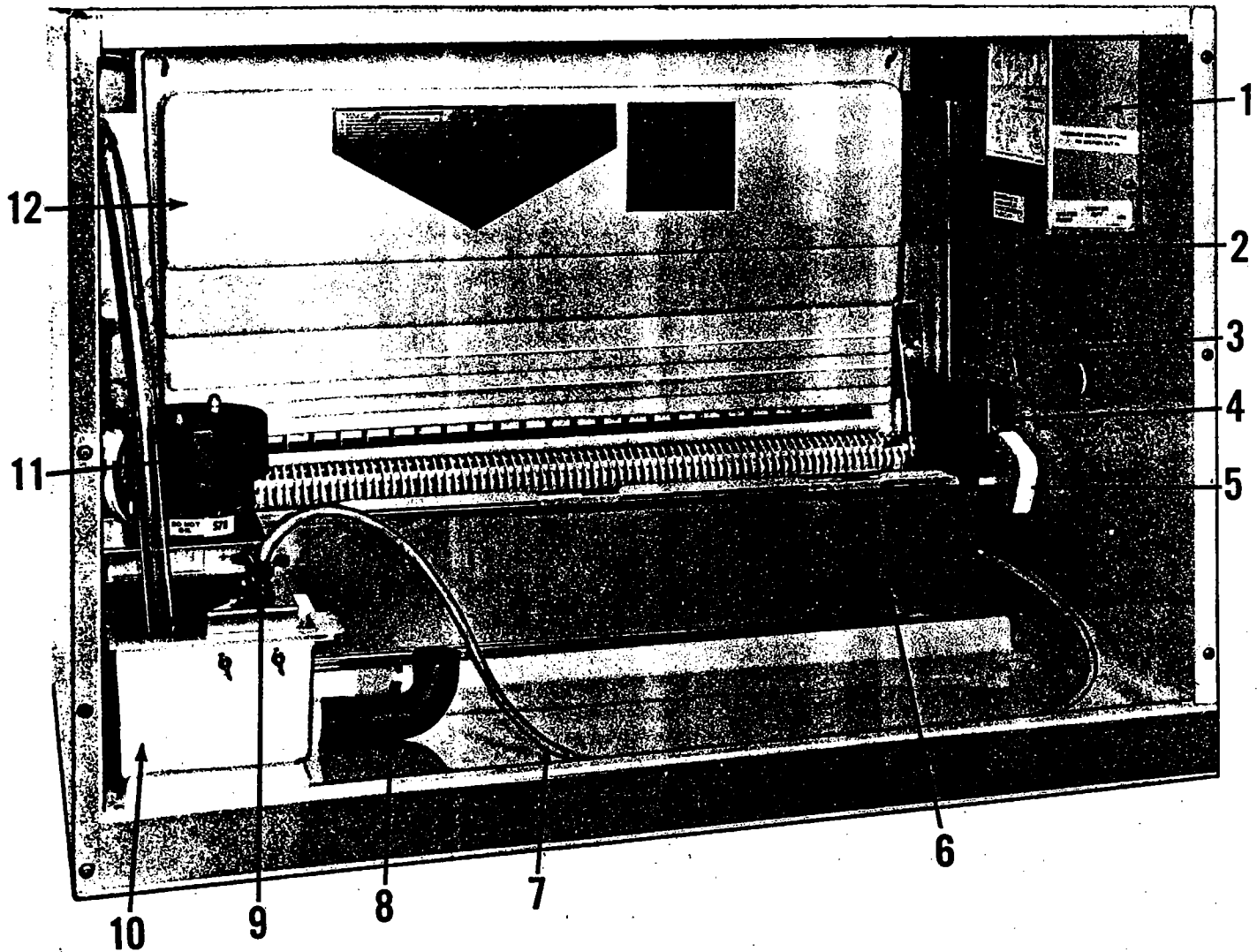

FIG. 4

1. Control box assembly.
2. Main On-Off toggle switch.
3. Harvest rack.
4. Damper bin door switch assembly.
5. Damper door.
6. Ice chute.
7. 1/4" water supply tubing.
8. Overflow elbow.
9. Float valve assembly.
10. Sump trough assembly.
11. Water pump.
12. Water curtain.

FIG. 5
ICE MAKING SECTION WITH CURTAIN, ICE CHUTE & WATER PUMP REMOVED

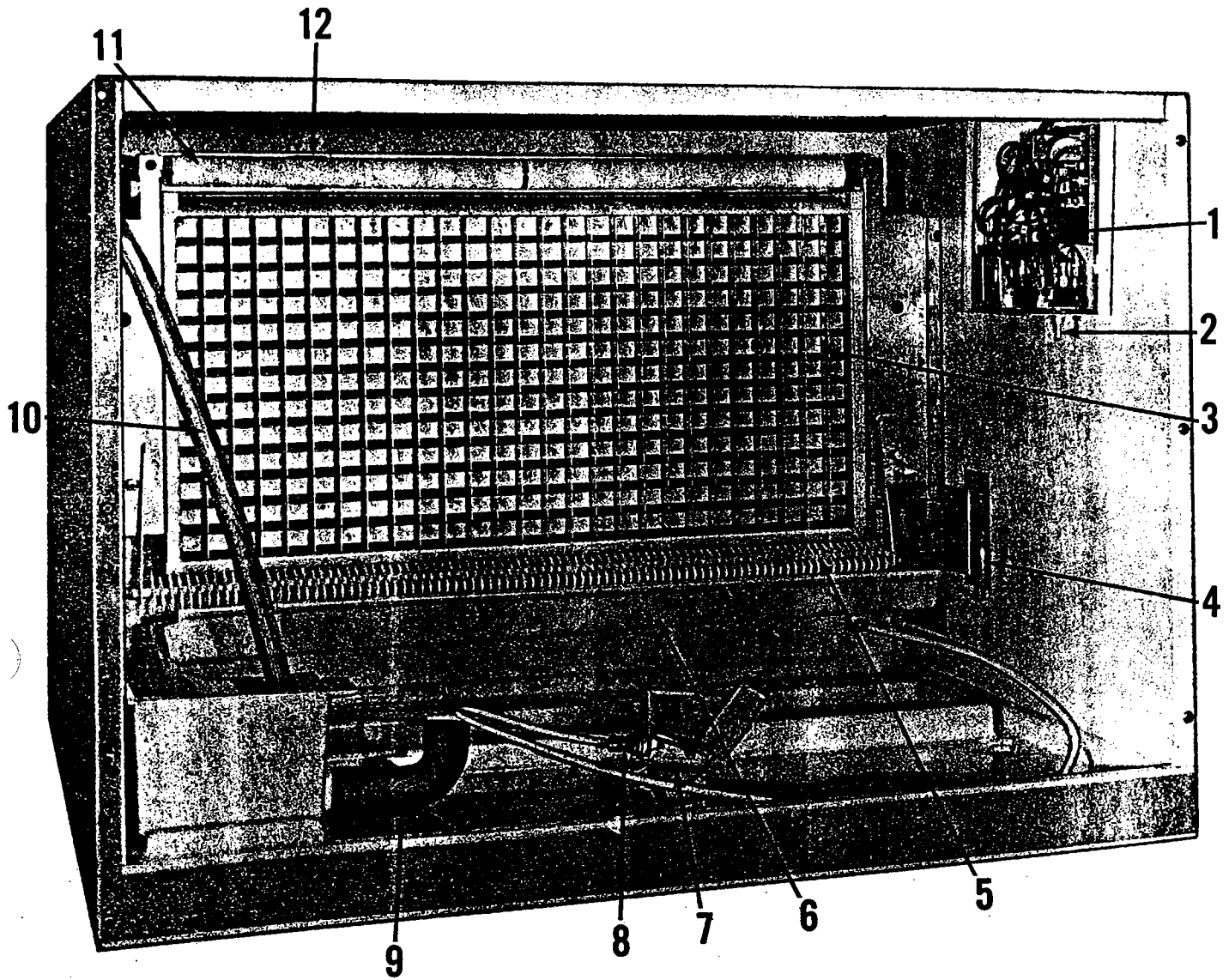

FIG. 5

1. Control box with cover removed.
2. Main On - Off toggle switch.
3. Evaporator.
4. Damper bin door switch.
5. Harvest rack.
6. Sump trough assembly.
7. Float valve mounting bracket.
8. Float valve assembly.
9. Overflow elbow.
10. 1/2" water supply tubing.
11. Water distributor.
12. Locating clamps for distributor.

FIG. 6
CONTROL BOX ASSEMBLY

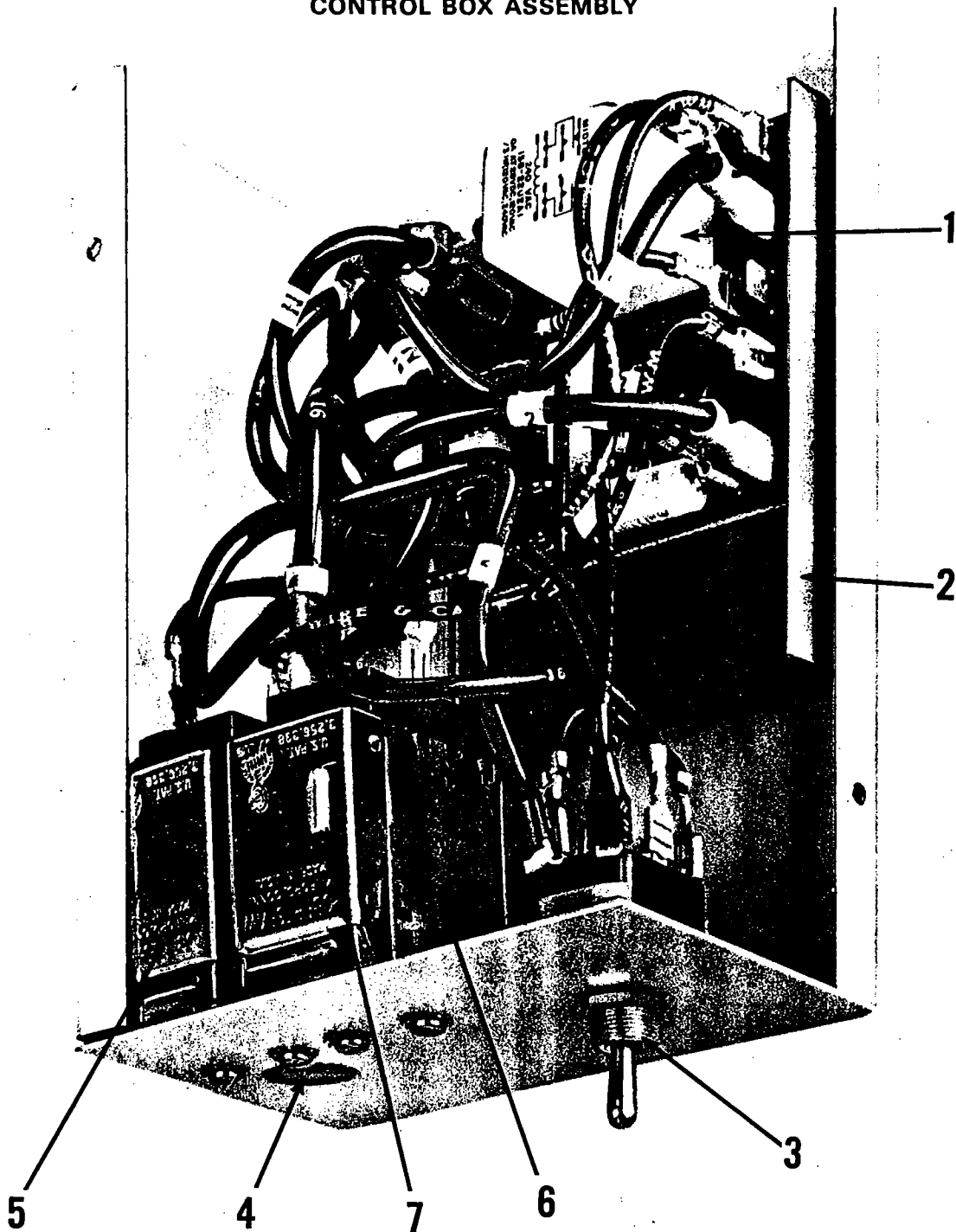

FIG. 6
CONTROL BOX ASSEMBLY

1. Timer, solid state.
2. Mounting track, timer.
3. Main On-Off toggle switch.
4. Low pressure cut-in adjustment screw.
5. Low pressure cut-in control.
6. High pressure cut-out water, water cooled only.
7. High pressure cut-out manual reset, water cooled only.

WATER PUMP ASSEMBLY

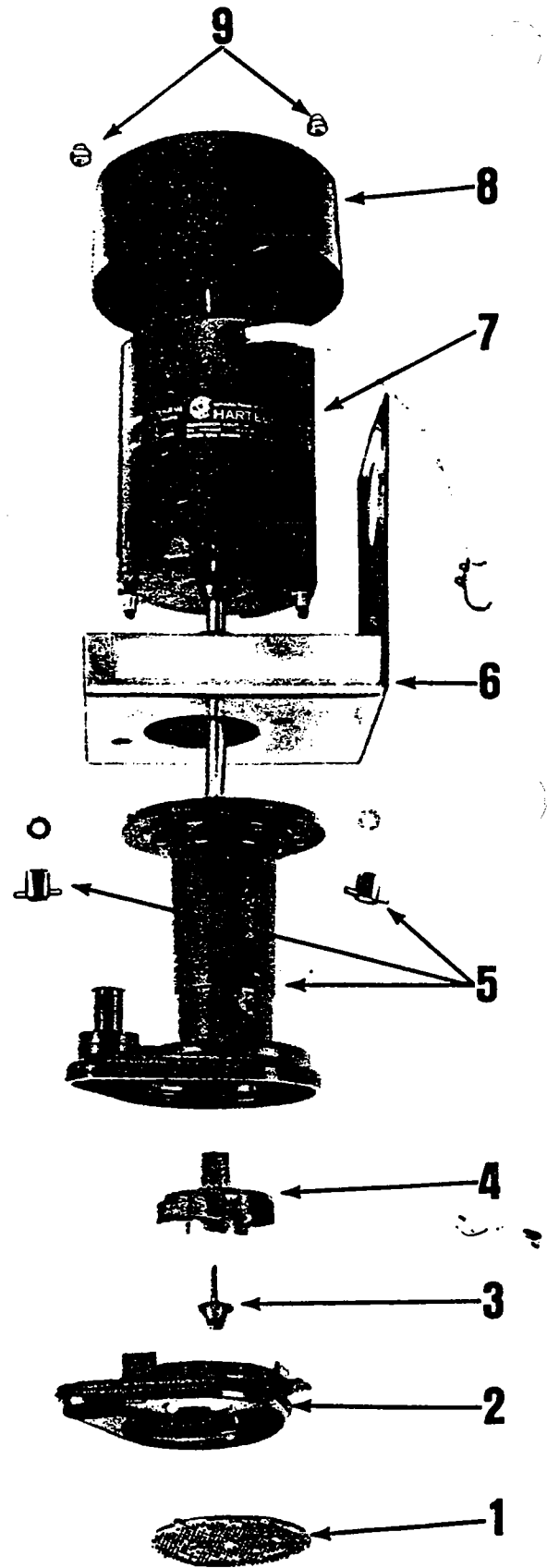
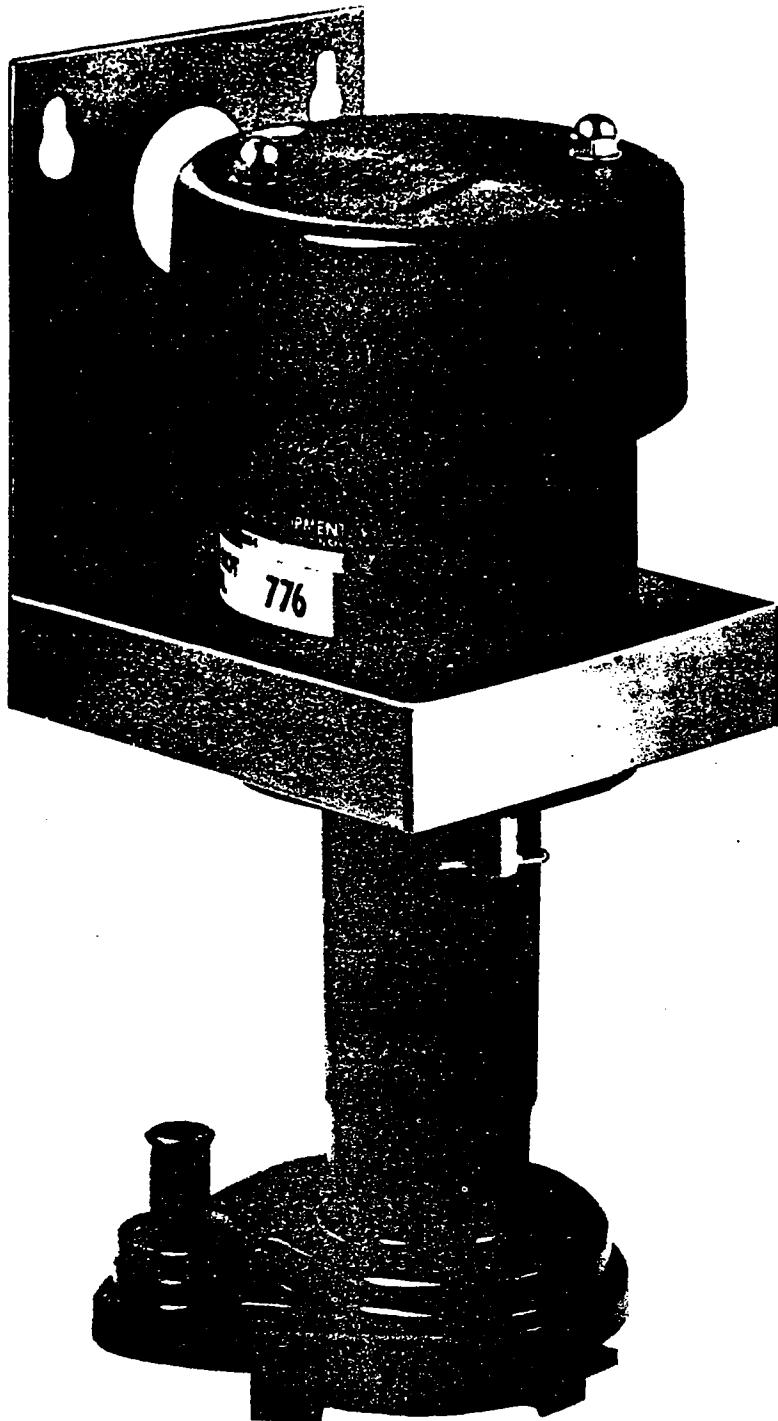

FIG. 7

- 1. Inlet screen.
- 2. Impeller housing.
- 3. Impeller thumb nut.
- 4. Impeller.
- 5. Motor shaft housing & mounting nuts.
- 6. Pump bracket.
- 7. Pump motor.
- 8. Pump cover.
- 9. Cover mounting nuts.

Water pump is available as a complete pump assembly less cover & bracket.
 Motor not available separately.

C-0600 SYSTEM CONTROL AND SEQUENCE OF OPERATION

The main ON-OFF toggle switch for the cuber is located on the control box. The toggle switch has three positions; the center or "OFF" position, the "WATER PUMP" position (only the water pump runs), and the "ICE" position.

Placing the toggle switch in the Ice position will start the compressor, the condenser fan motor (air cooled cubers), and the water pump through terminals 4 & 5 on the solid state timer. The cuber is now in the freeze cycle. As water flows over the evaporator ice will begin to form on the cube plate.

As the ice forms the suction pressure will continually decrease. At a preset point the reverse acting low pressure cut-in control will close its contacts. 10 PSIG for regular and dice cubes and 11 PSIG for half dice cubes.

Closing of the low pressure cut-in control contacts energizes the time delay circuit of the solid state timer through terminal 1. The remaining freeze time is dependent upon the timer setting. At the end of the timing sequence the timer relay will energize. This will open the relay contacts between terminals 4 & 5 shutting off the water pump and condenser fan motor and close its contacts between terminals 3 & 4 energizing the hot gas solenoid valve. The cuber is now in the harvest cycle.

NOTE: To manually place the cuber in harvest, see timer description and check-out procedure. Page 21.

Shortly after the hot gas solenoid valve opens, the suction pressure will rise to 38 PSIG plus. This opens the low pressure control contacts. The solid state timer relay remains energized through the timer relay interlock circuit.

As the harvest cycle progresses the hot gas will warm the evaporator allowing the ice to fall out of the evaporator and through the ice chute, opening the damper door. Opening of the damper trips the bin switch, momentarily de-energizing the entire cuber. The timer relay will return to its normal position, de-energizing the hot gas solenoid and energizing the water pump and condenser fan motor (air cooled cubers). The cuber now in a new freeze cycle.

The ice cuber will continue to cycle until the ice storage bin is full. The cuber automatically discontinues ice production as the ice fills the chute, holding the damper door and the bin switch open.

If, for some reason, the bin switch would fail when the ice falls through the ice chute, the cuber would remain in the harvest cycle until the hot gas raised the suction temperature to $70^{\circ} \text{ F} \pm 5^{\circ}$. At this time the safety thermodisc, located on the suction line, would open its contacts, de-energizing the timer relay and hot gas solenoid valve, placing the cuber back into the freeze cycle. As the evaporator begins to cool, the thermodisc will reclose its contacts at $40^{\circ} \text{ F} \pm 5^{\circ}$.

A high pressure cut-out control is used on the water cooled models only. This control shuts the entire cuber off should the condensing pressure become too high.

See page 22 Bin Thermostat for CY-0614AS & CY-0615WS models.

REFRIGERATION CYCLE — C-0600 (See Page 15)

*(Assume the cuber is operating at 90° F Air and 70° F Water)

Freeze Cycle

During the freeze cycle the high pressure discharge gas is pumped into the condenser. (*Air cooled-Ave.

head 160-165 PSIG. Water cooled Ave. head 125-130 PSIG.) The high pressure gas is condensed to a high pressure liquid. The high pressure liquid leaves the condenser, goes through the filter-drier, and into the heat exchanger. On water cooled cubers the liquid will go from the condenser into a receiver. The receiver stores extra refrigerant when it is not used. This depends on operating conditions.

The high pressure liquid leaves the heat exchanger at a reduced temperature making the system more efficient. The high pressure liquid is then metered into the evaporator by a thermostatic expansion valve. The expansion valve regulates the rate of refrigerant liquid flow into the evaporator in the exact proportion to the rate of evaporation of the refrigerant liquid in the evaporator. The expansion valve does this by responding to (1) the pressure in the evaporator (2) the temperature of the refrigerant gas leaving the evaporator using the valve feeler bulb to sense the gas temperature.

After the low pressure liquid evaporates to a low pressure gas, it passes through the suction line heat exchanger and into the compressor. The ave. suction pressure will start at approx. 20 PSIG and drop to approx. 8-10 PSIG when the cuber goes into harvest.

Harvest Cycle

The harvest is initiated by the solid state timer energizing the solenoid valve allowing high pressure hot gas to flow through the evaporator and harvest the ice. The suction pressure during the harvest is approx. *45-55 PSIG (air cooled) and 38-45 PSIG (water cooled). *The head pressure will drop to approx. 80-100 PSIG (air cooled). The cuber goes back into the freeze cycle automatically when the solenoid valve is closed by the harvesting ice tripping the bin switch.

The cuber is now in a new cycle.

C-0600 OPERATING CHARACTERISTICS*

	AIR COOLED			WATER COOLED	
	AIR TEMP.	FREEZE CYCLE	HARVEST CYCLE	FREEZE CYCLE	HARVEST CYCLE
HEAD PSIG	70	135-110	75-90	130-125	80-90
	80	150-125	80-95	130-125	80-90
	90	180-140	90-105	130-125	80-90
	105	210-170	110-120	130-125	80-90
SUCTION PSIG	70	18-6	35-45	19-6	38-45
	80	20-8	40-50	20-7	38-45
	90	21-8	50-60	21-8	38-45
	105	22-9	55-65	22-8	38-45

*These are approx. characteristics that vary depending on the operating conditions.

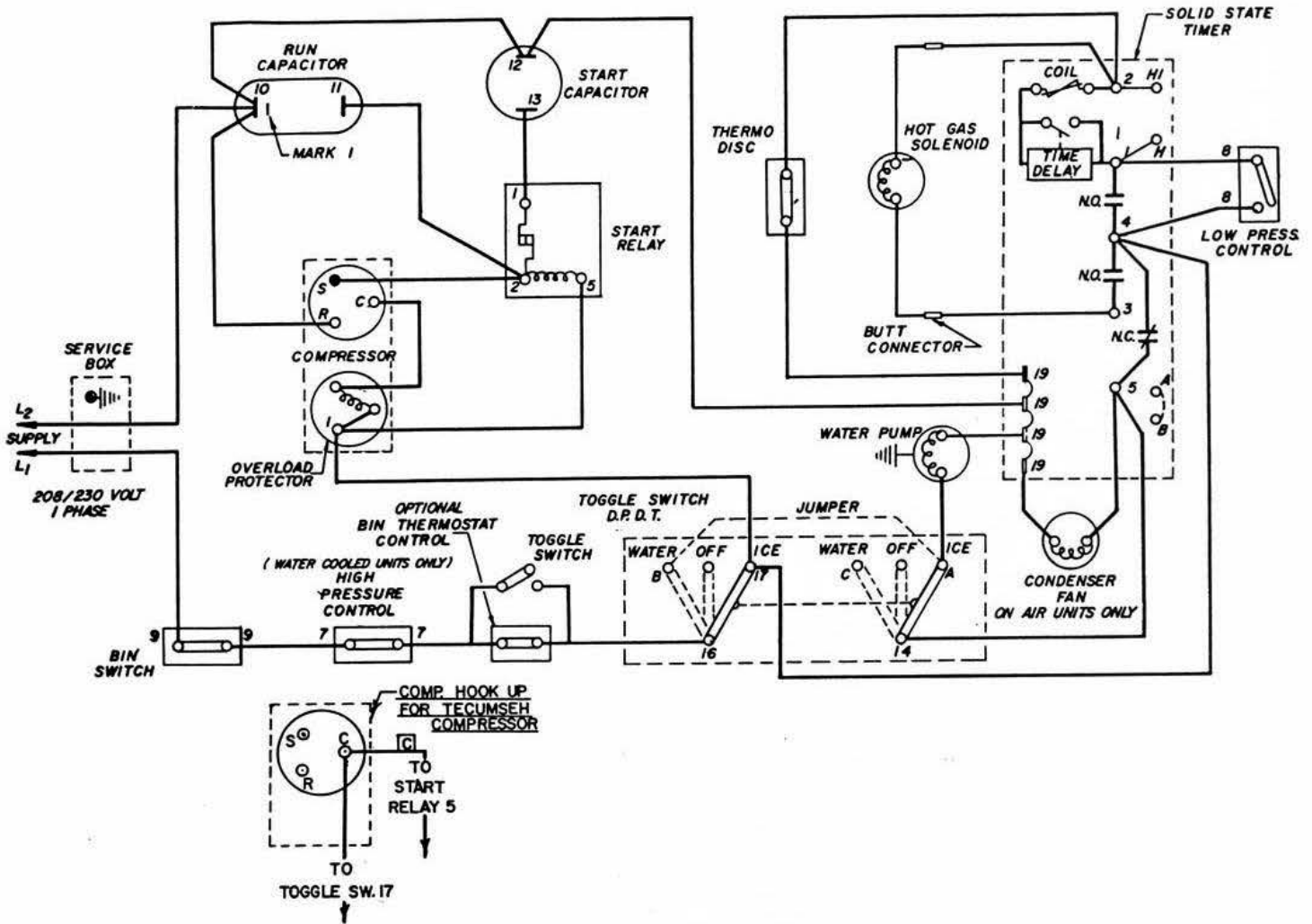

**WIRING DIAGRAM C0600 SERIES CUBER 208/230 VOLT
1 PHASE SOLID STATE TIMING 50 OR 60 HZ.**

SHOWN AT BEGINNING OF ICE-MAKING CYCLE, HIGH PRESSURE CONTROL NORMALLY CLOSED, LOW PRESSURE CONTROL NORMALLY OPEN, CONDENSER FAN ON AIR MODEL'S ONLY.

SEQUENCE OF ICE-MAKING & HARVEST CYCLE

1. SET TOGGLE SWITCH TO 'ICE' POSITION. THIS ENERGIZES THE WATER PUMP, COMPRESSOR, & CONDENSER FAN MOTOR.
2. AS ICE FORMS, GAS PRESSURE DECREASES, CAUSING THE LOW PRESSURE CONTROL TO CLOSE AND ENERGIZING THE TIME DELAY CIRCUIT.
3. AFTER THE TIME DELAY INTERVAL, THE TIMER RELAY CONTACTS TRANSFER FROM NORMALLY CLOSED TO NORMALLY OPEN, CAUSING THE WATER PUMP & CONDENSER FAN MOTOR TO SHUT OFF & THE HOT GAS SOLENOID TO SWITCH INTO HARVEST.
4. DURING HARVEST, GAS PRESSURE & TEMPERATURE BEGIN TO RISE, CAUSING THE LOW PRESSURE CONTROL TO OPEN, PREPARING IT FOR A NEW CYCLE. AS TEMPERATURE CONTINUES TO RISE, THE ICE SLAB DROPS & TRIPS THE DAMPER DOOR WHICH INTURN OPENS BIN SWITCH MOMENTARILY. THIS CAUSES THE HOT GAS SOLENOID TO SHUT OFF. CUBER GOES INTO NEW FREEZE CYCLE.

NOTE: WHEN THE BIN THERMOSTAT CONTROL TOGGLE SWITCH IS IN THE OFF POSITION, THE THERMOSTAT WILL CONTROL THE ICE LEVEL IN THE STORAGE BIN. WITH TOGGLE SWITCH IN THE ON POSITION, THE BIN SWITCH CONTROLS THE ICE LEVEL.

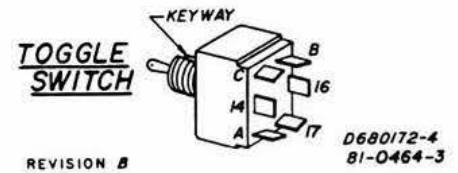

CAUTION: DISCONNECT POWER BEFORE WORKING ON ELECTRICAL CIRCUITRY.

C-0600 SERIES TUBING SCHEMATIC — REFRIGERATION CYCLE

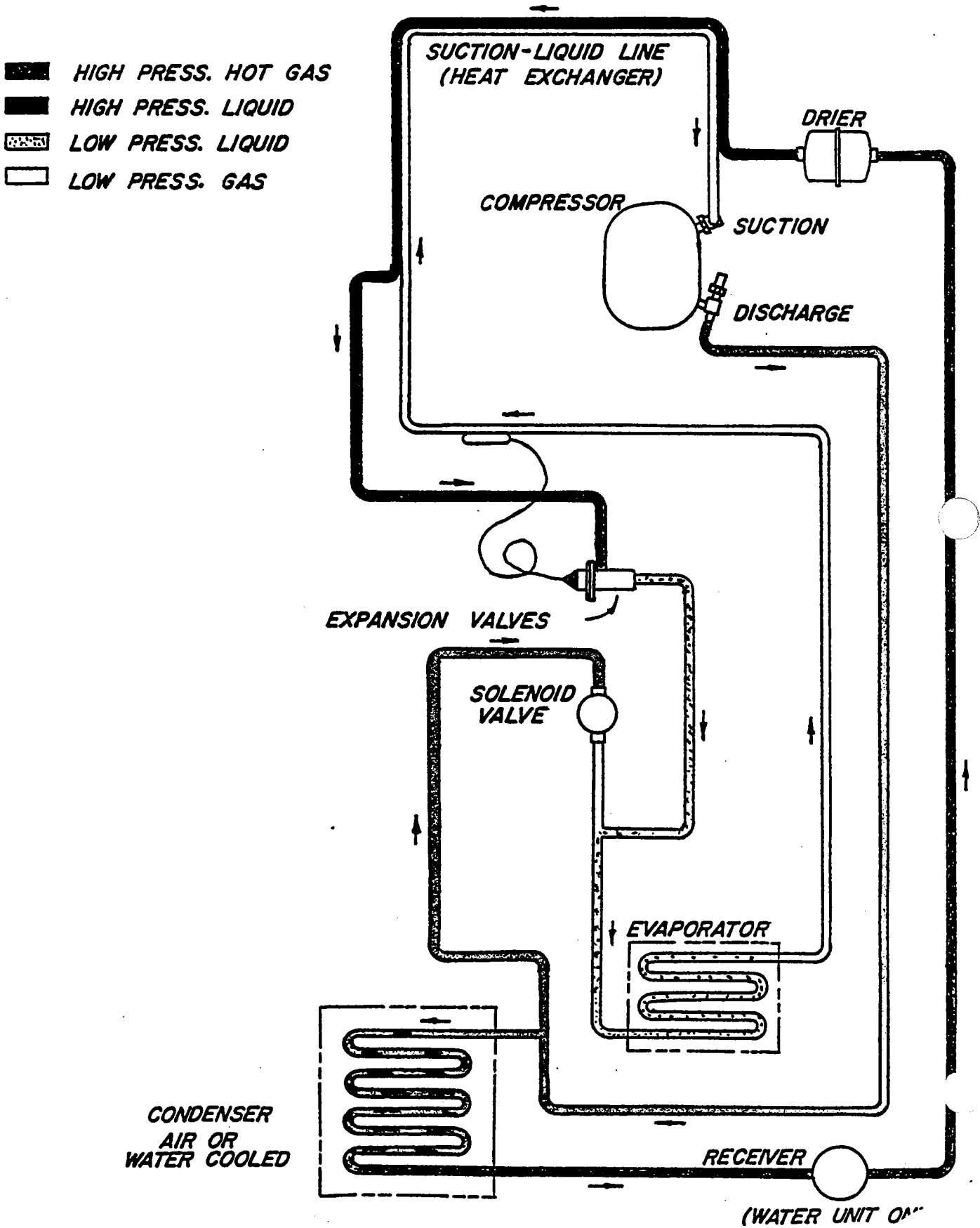

C-0600 CUBER SPECIFICATIONS

SELF-CONTAINED "600" SERIES ICE PRODUCTION (Pounds per 24 Hours)*	Incoming Water Temp. (F)		Room Temperature (F)		
	Air Cooled Models	(F)	70°	80°	90°
			50°	610	560
		70°	540	500	450
		90°	490	460	420
	Water Cooled Models	50°	600	590	580
		70°	530	520	510
		90°	460	450	440

*Approximate production for Dice Cube and Half Dice Cube (Regular Cube production slightly lower).
 "600" Series Stack-On unit also available (doubles the ice making output).
 Portable water consumption gallons per 24 hours =
 $1.7 \times 24 \text{ Hr. Ice Production.}$
 8.34

REMOTE SERIES 600 CUBER WITH AC-0695A CONDENSER

Approximate Production Per 24 Hours* (Pounds)			
Cond. Air Temp. °F	Water Temperature °F		
	50	70	90
-20 to 70	580	530	490
90	560	510	470
100	520	470	430
110	490	450	410

*Based on 70° F air at ice maker.

"600" SERIES BIN OPTIONS	C-610	C-900
Ice Storage* — lbs.	580	1040
Height — inches	31-7/16	44
Width — inches	48	48
Depth — inches	29-9/16	34
Approx. Shipping Wt. — lbs.	148	270
Carton Volume — cu. ft.	32.5	49

NOTES: Cast aluminum Bin Legs. No. 606 adjusts from 6-1/2" to 7-1/2" — No. 612 from 12" to 13-1/2". Casters also available. *Rated storage capacity based on 35 lbs. per cu. ft. at 90% internal volume.

CONDENSER WATER USAGE* MODEL C-0600W SERIES			
Water Temp °F	50°	70°	90°
Gal/Day	400	720	1650

*At factory head pressure setting of 125 PSIG and a clean condenser.

"600" SERIES MODELS	Cube Type	Condenser	Exterior Finish	Approx. Ship. Wt. — lbs.
CR-0600A	Regular	Air	Fawn	315
CR-0600AS	Regular	Air	Stainless	315
CR-0601W	Regular	Water	Fawn	305
CR-0601WS	Regular	Water	Stainless	305
CD-0602A	Dice	Air	Fawn	325
CD-0602AS	Dice	Air	Stainless	325
CD-0603W	Dice	Water	Fawn	315
CD-0603WS	Dice	Water	Stainless	315
CY-0604A	Half Dice	Air	Fawn	335
CY-0604AS	Half Dice	Air	Stainless	335
CY-0605W	Half Dice	Water	Fawn	325
CY-0605WS	Half Dice	Water	Stainless	325

Model	Minimum Ampacity	Cube Size	Shipping Weight	Required Condenser
CR-0690N	13.3	Regular	370	AC-0695A
CD-0692N	13.3	Dice	370	AC-0695A
CY-0694N	13.3	Half Dice	380	AC-0695A

Standard interconnecting refrigerant lines.

Model	Line Length
RT-20	20 feet
RT-35	35 feet
RT-50	50 feet

THREE CUBE SIZES...Regular (1-1/8" x 1-1/8" x 7/8" — 30 cubes per lb.), "Dice" (7/8" x 7/8" x 7/8" — 48 cubes per lb.) and "Half Dice" (3/8" x 7/8" x 7/8" — 98 cubes per lb.).

60 CYCLE

50 CYCLE

CUBER MODEL	CD CR CY 600 SERIES WATER COOLED 60 CYCLE	CD CR CY 600 SERIES AIR COOLED 60 CYCLE	CD CR CY 600 SERIES WATER COOLED 50 CYCLE	CD CR CY 600 SERIES AIR COOLED 50 CYCLE
Compressor Model	SSC4-0100-CAV-218	SSC4-0110-CAV-218	SSE4-0100-CAG-206	SSE4-0100-CAG-206
Compressor Voltage	208/230-60Cy-1Ph	208/230V-60Cy-1Ph	230V-50Cy-1Ph	230V-50Cy-1Ph
Winding Resistance Common to Run	1.40-1.65	1.40-1.65 OHMS	1.38-1.58	1.38-1.58 OHMS
Winding Resistance Common to Start	4.02-6.57	4.02-6.57 OHMS	8.43-9.69	8.43-9.69 OHMS
Start Capacitor Rating	145-175MFD220V	145-175MFD220V	145-175MFD-220V	145-175MFD-220V
Run Capacitor Rating	20 MFD-370V	20 MFD-370V	20MFD-370V	20MFD-370V
Fan Motor Amps	—	.7 AMPS	—	.54 AMPS
Fan Motor Watts	—	35 Watts	—	23.2 Watts
Fan Motor Volts	—	230 Volts	—	230 Volts
Fan Winding Resistance	—	55 OHMS	—	18 OHMS
Solenoid Valve Volts	230 Volts	230 Volts	230 Volts	230 Volts
Solenoid Valve Amps	.1 AMPS	.1 AMPS	.6 AMPS	.6 AMPS
Pump Volts	208/230 Volts	208/230 Volts	220 Volts	220 Volts
Drum Pump Amperage	.99 AMPS	.99 AMPS	.8 AMPS	.8 AMPS
Refrigerant Charge — R-12	30 Ozs.	42 Ozs.	30 Ozs.	42 Ozs.
Freeze Amperage	4.0-7.0 AMPS	5.0-8.5 AMPS	—	—
Defrost Amperage	10.1 AMPS	10.1 AMPS	—	—

C-0600 COMPONENT CHECK-OUT PROCEDURE

Check out procedure for compressor and compressor start components.

(A) Compressor will not run —

If the compressor fails to start and run properly; it is possible that the external electrical components may be defective, the protector may be open, a safety device may be tripped, or other conditions may be preventing compressor operation.

1. Check for voltage at compressor terminals. If there is no voltage, check back from the compressor to the power supply to find where the circuit is interrupted. Check the bin switch, high pressure cut-out (water cooled units only — has a manual reset on the control) and the toggle switch for proper operation.
2. If power is available at the compressor terminals and the compressor does not run, check the voltage at the compressor while attempting to start the compressor. If the voltage is below 90% of the nameplate voltage, it is possible the motor may not develop sufficient torque to start. Check to determine if the power supply is adequate, electrical connections are loose, the circuit is overloaded, or if supply wire sizes are adequate.
3. A defective capacitor or relay may prevent the compressor from starting. If the compressor attempts to start, but is unable to do so, or if the compressor hums or trips out on the overload protector, check:

RELAY — Potential type.

The relay contacts should open as the compressor comes up to speed.

Remove the wire leads from the relay terminals. Use a high voltage ohmmeter to check for continuity through the relay coil. Replace the relay if there is no continuity.

Use an ohmmeter to check across the relay contacts. Potential relay contacts are normally closed when the relay is not energized. Replace the relay if there is no continuity.

CAPACITORS Fig. 3

Any capacitor found to be bulging, leaking, or damaged should be replaced.

CAUTION: Before removing leads for testing purposes, short across capacitor terminals to discharge capacitor.

A quick check is to replace suspected capacitors with a known good capacitor. Be sure only specified capacitors are used.

If a capacitor tester is not available, an ohmmeter may be used to check run and start capacitors for shorts or open circuits. Set the ohmmeter to its highest resistance scale, and connect prods to capacitor terminals.

- A. With a good capacitor, the indicator should first move to zero, and then gradually increase to infinity.
- B. If there is no movement of the ohmmeter indicator, an open circuit is indicated.
- C. If the ohmmeter indicator moves to zero and remains there or on a low resistance reading, a short circuit is indicated.

(B) If compressor fails to start or blows fuses (start relay and capacitors are functional) proceed to check compressor as follows:

CAUTION: Turn power off. Before removing supply leads to compressor, short across both capacitor terminals to discharge capacitors.

1. Using an ohmmeter check for continuity from terminals C to R and C to S. If the compressor is warm, wait one hour for compressor to cool and recheck. The internal overload protector can cause a lack of continuity. If continuity cannot be established through all motor windings, the compressor should be replaced.
2. Check the compressor motor for ground by means of a continuity check between terminal C, R, and S to the compressor shell. If there is a continuity reading, the compressor is grounded and should be replaced.

(C) If compressor starts but trips repeatedly on the overload protector check:

1. Operating pressures should be within limitations of normal operating conditions shown on Page 13.
2. Check line voltage at the compressor terminals at start-up. Design voltage is nominal 208 or 230 voltage. Minimum operating voltage 198 and maximum operating voltage is 250.
3. Check the amperage drawn while the compressor is operating. Under normal operating conditions, the continuous amperage drawn will seldom exceed 100% of compressor nameplate amperage and should never exceed 120% of nameplate amperage. High amperage can be caused by:

Low voltage.

High head pressure.

High suction pressure.

Defective running capacitors or starting relay.

Compressor mechanical damage.

FAN MOTOR Fig. 3

The fan motor is a shaded (4) pole, impedance protected fractional horsepower motor; normal speed approx. 1610 RPM.

Check Out Procedure

1. Check wiring and voltage across terminals 5 & 19.
2. If there is power, place toggle switch into neutral position. Remove lead from the fan motor at timer terminal 5. Check fan motor resistance.
If the windings appear to be open and fan motor is hot, allow 30 minutes for the overload to close and recheck. If there is still no reading, the motor is defective. Replace.
4. If the motor appears hot and fan shaft is tight, remove oil plug and lubricate bearings. A good refrigeration oil can be used. If motor remains tight, replace.

WATER PUMP

Recirculating pump used to pump supply water to the water distributor tube.

Fig. 7 shows disassembly of the water pump for cleaning and to remove the stainless steel mounting bracket and pump cover.

HOT GAS SOLENOID VALVE Fig. 3

The hot gas solenoid is a normally closed valve that is opened to permit hot gas flow through the evaporator to harvest the ice.

Check Out Procedure

1. Check the coil resistance at lead No. 2 & 3. Remove one lead to isolate coil.
2. If the coil is good, check the thermodisc and timer.
3. If the solenoid valve leaks when closed or will not open, but the coil is good, the internal parts should be examined and replaced if necessary. The refrigerant charge will have to be blown to accomplish this.

C-0600 CONTROLS DESCRIPTION AND CHECK-OUT PROCEDURE

ELECTRICAL CONTROL BOX Fig. 6

The control box contains the high pressure control (water cooled units only), low pressure cut-in, toggle switch, and the solid state timer. The control box is located inside the evaporator compartment, mounted on the partition panel. Fig. 4

TOGGLE SWITCH

The main power "ON and OFF" toggle switch is a double pole, double throw switch with "OFF" in the center position. With the toggle switch in the "water pump" position, only the water pump will operate. This is for circulating cleaning solution and checking pump operation.

With the toggle switch in the Ice position, the water pump compressor and condenser fan (air cooled models) operate for a normal ice making cycle.

TOGGLE SWITCH
(REAR VIEW)

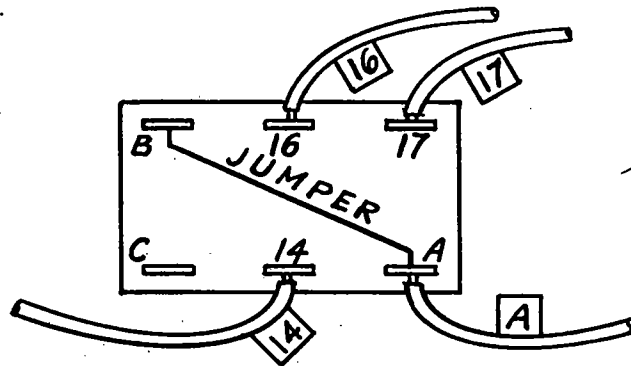

Check Out Procedure

1. Turn power off. Check toggle switch by removing all wires on one side (terminals B, 16 & 17) and make continuity check with ohmmeter. If the results are positive, rewire leads to assigned terminals. Likewise examine the opposite side of the toggle switch (terminals A, C & 14).
2. Check also the jumper for proper position and continuity. Jumper should be across terminals A & B.

HIGH PRESSURE CUT-OUT — WATER COOLED UNITS ONLY. Fig. 6 Item 6

This high pressure cut-out shuts off the entire cuber, should the head pressure exceed 275 PSIG. If the cuber goes out on high head pressure, the high pressure cut-out control has to be manually reset after the cause of the high head pressure condition has been corrected.

Check Out Procedure

With the power supply turned off to the cuber, place an ohmmeter across the terminals after removing one of the leads. Push reset button. If no continuity reading, replace control.

LOW PRESSURE CUT-IN CONTROL Fig. 6 Item 5

This is a Robert Shaw low pressure reverse acting control that closes its contacts on a drop in pressure and opens its contacts on a rise in pressure. The low pressure control contacts close at 10-1/2 PSIG for regular and dice cubes, and 11 PSIG for half dice cubes. The differential is fixed at 12 PSIG so the contacts will open at approx. 22 PSIG.

The low pressure control is used to initiate the time delay circuit of the solid state timer. If the timer is set at its max. or min. setting and the proper bridge thickness cannot be obtained, the low pressure control cut-in point must be recalibrated.

Check Out Procedure

1. Install a service cage on the suction service valve and voltmeter prods on terminals 1 and the common binding post "19".
2. Turn the cuber on. As it runs slowly close the suction service valve down (front seat) so the suction pressure will fall. When the suction pressure reaches 10-12 PSIG the contacts should close giving you a 208/230 volt reading.
3. To change the cut-in point, turn the Phillip head screw clockwise to increase the cut-in point and counter-clockwise to decrease the cut-in point. Fig. 6 Item 4.
4. Allow the timer to time out and place the cuber in harvest. The suction pressure will rise, opening the low pressure control contacts at approx. 22 PSIG.

SOLID STATE TIMER Fig. 6

primary function of the timer is to control the ice bridge thickness and to initiate the harvest cycle by energizing the hot gas solenoid valve and de-energizing the water pump and condenser fan motor. The timer is activated by the low pressure cut-in control and is de-energized by the opening of the bin switch, or thermdisc.

The Model C-0600 Ice Cubers are manufactured with several different make solid state timers. All these timers are interchangeable. The wiring is the same — be sure the numbered wires are placed on the terminals with corresponding numbers. When replacing the timer check for proper voltage setting — determined by the location of the jumper wire.

— All Dual Voltage Timers P/N 24-0623-3, place a jumper wire across terminals 2 & A for 230 Volt or across terminals 2 & B for 115 Volt units. The jumper wire must be in place for the timer to operate.

SOLID STATE TIMER ADJUSTMENT AND BRIDGING**TIMER ADJUSTMENT TO INCREASE OR DECREASE BRIDGING BETWEEN CUBES.**

To adjust the solid state timer —

1. Remove control box cover, Fig. 4, Item 1.
2. Locate the timer and the dial.
3. To increase bridge thickness, rotate dial clockwise.
4. To decrease bridge thickness, rotate dial counter-clockwise.

Adjustments should not be greater than 10° to 15° at one time. After each adjustment allow the cuber to produce two ice harvests and observe bridge thickness. Repeat this procedure as required.

For optimum ice production and maximum cube separation, the ice connecting the individual cubes should be 1/8" thick at the center of the ice slab. (Note: Bridging will vary in the thickness from top to bottom of evaporator.)

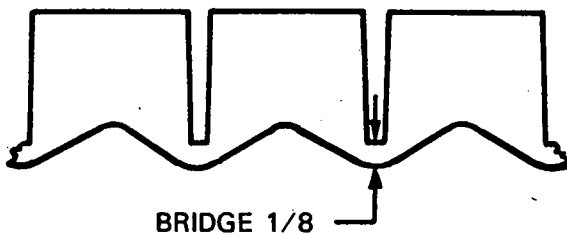

To change bridge thickness, an adjustment of the solid state timer is required. This timer is located inside the electrical control box.

CAUTION: Before removing the control box cover, the cuber's main power supply should be turned off to prevent any electrical shock or accidental wire shorting.

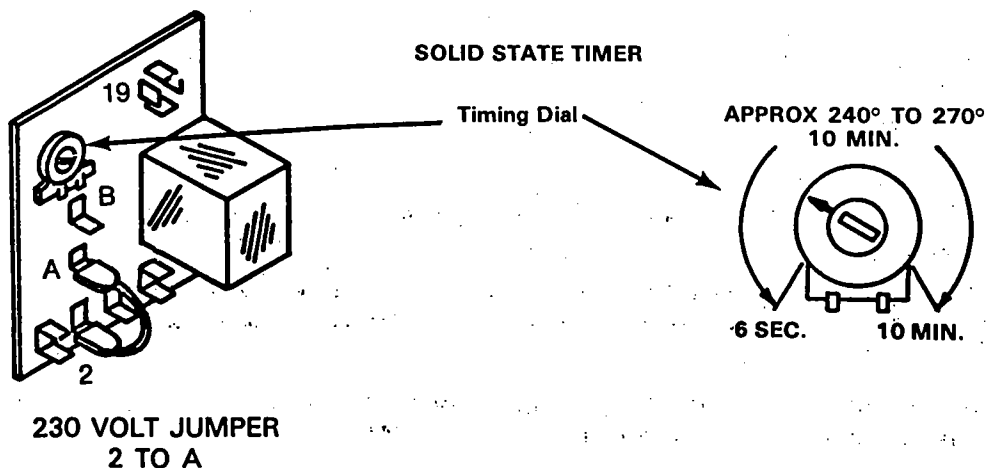

Check Out Procedure

1. Check wiring of timer to wiring diagram page 14.
2. Set toggle switch to OFF position. Place a jumper wire across the low pressure control.
3. Mark approximate position of timing dial and turn fully counterclockwise to get a short time delay period (30 to 60 sec.).
4. Place the toggle switch into ice making position. The timer, fan motor, water pump, and compressor should be energized. With the low pressure control jumpered, check for a 230 voltage reading at terminals 1 and 19 or N with a voltmeter. Note: After the hot gas valve opens, the suction pressure will rise opening the low pressure contacts.
5. At the end of a predetermined timing period, the timer relay contacts should transfer, turning the fan motor and water pump OFF, and energizing the hot gas solenoid. Using a voltmeter there should be a 230 voltage reading at terminals 3 and 2 confirming proper operations.
6. If the relay contacts fail to transfer after 2-3 minutes with the timer set at minimum setting, check to see if the thermo-disc and bin switch are in normally closed position. If the bin switch and thermo-disc are closed, replace timer.
7. With the cuber in the harvest sequence, trip the bin switch or place the toggle switch in the "OFF" position and back into "ICE" position. Either of these actions should deactivate the timer relay placing the cuber back in freeze. If proper sequence of all operations is accomplished the timer is in working order. If not, replace timer.
8. Place toggle switch in "OFF" position. Remove jumper wire from low pressure control. Reset timer dial to previous position. Test cuber for proper operation.

NOTE: If needed the solid state timers can be manually tripped to place the cuber in harvest.

Timers with H & H₁ terminals can be placed in harvest by shorting across H & H₁ terminals. This override the timing sequence. Timers without H & H₁ terminals, place in harvest by shorting across terminals 3 & 4 on the timer. This overrides the timer completely.

SAFETY THERMO-DISC Fig. 3

The thermo-disc is a safety control located on the suction line. The control is temperature sensitive and opens at 70° F ± 5° and closes at 40° F ± 5° F. The thermo-disc prevents the cuber from overheating. If the bin damper door switch should fail when the ice harvests, the cuber hot gas valve would remain open. The suction temperature would rise and the thermo-disc would open at 70° F. This will place the cuber back into the freezing cycle by de-energizing the timer and hot gas solenoid.

Check Out Procedure

1. The thermo-disc is a normally open control at 70° F and above, and recloses at 40° F. Closing is accomplished by operating the cuber on for approx. 5 minutes. The thermo-disc will open only if the cuber sits idle in room temperature for a period of time, or the cuber bin switch fails in harvest.
2. Disconnect the thermo-disc leads at terminals 2 and N of the timer, after the cuber has been operating. Check continuity with ohmmeter. If there is no reading, check for contact between the suction-line and the thermo-disc. If contact is adequate, replace thermo-disc.
3. To check the cut-out temperature of the thermo-disc, remove the damper door from the ice chute. Start the cuber and wait for the evaporator to harvest. With the door removed, the unit will remain in its harvest cycle. This will increase the suction line temperature sharply until the thermo-disc reaches its calibrated opening point (70° ± 5° F). From the time the ice has harvested to the point the thermo-disc opens, under normal ambient temperatures, it should take no longer that 2-3 minutes.

DAMPER DOOR (BIN) SWITCH Figs. 4 & 5

A micro switch is used to cycle the cuber from harvest to freeze cycles and shut the cuber OFF when the ice bin is full. The switch is tripped by the damper door counter-weight when the harvesting ice falls through the ice chute.

Check Out Procedure

1. Check free movement of damper door.
2. Check bin switch arm for ON & OFF action, by opening or closing damper door. Switch should open when the damper door is open approx. 1 to 1-1/2".
3. Turn main power supply off to the cuber. Make a continuity check across the switch. Be sure to remove one lead first. Tripping the metal arm will open the switch contacts and releasing the arm will close the contacts. To verify switch action open and close the switch. Replace switch, if defective.

**LOW PRESSURE CUT-OUT — Fig. 11 Item 10
(Used on the C-0690N Models Only)**

This is a Robert Shaw low pressure control that opens its contacts on a fall in suction pressure, 2 PSIG, and closes its contacts on a rise in pressure, 27 PSIG.

The low pressure cut-out is used to start and stop the compressor.

Check-Out Procedure

1. Install a service gage on the suction service valve or port (Fig. 1 Item 11).
2. Placing the toggle switch in the OFF position or holding the damper door open will de-energize the liquid solenoid valve, Fig. 8, Item 12. The suction side will pump down until the low pressure cut-out opens its contacts at 2 PSIG.
3. If the compressor shuts off several pounds above or below this 2 PSIG setting, reset by turning the adjustment screw clockwise to increase the cut-out point and counter-clockwise to decrease the cut-out point.

BIN THERMOSTAT CONTROL (Used On CY-0614AS & CY-0615 WS)

The bin thermostat is used to control ice level in the bin by stopping and starting the cuber. The location of the sensing bulb will determine the ice level.

The toggle switch on the thermostat housing can be used to jumper out the thermostat. Placing the toggle switch in the upper position, the thermostat will control the ice level. With the toggle switch in the lower position, the bin switch (located in the ice chute) will control the ice level.

ALTITUDE EFFECT

The thermostat operating point shifts approximately 3/4° F lower for every 1000 ft. of elevation above sea level. For altitudes 2000 ft. and above the set point should be calibrated.

RECALIBRATION

Prepare a 32° F ice/water bath. Loosen the set screw and remove the black knob.* Place the thermostat bulb in the ice bath, rotate the loosened knob clockwise until the contacts just open (32° F). Then turn the dial counter-clockwise 1/4 turn. The cut-out point should then be at 36° F. Replace the knob* in such manner that the built-in "stop" does not allow the knob to turn clockwise to a colder position. Tighten the set screw.

* — Later models are screw driver instead of knob adjustable and have no "Stop".

C-0690 CUBER WITH AC-0695A REMOTE CONDENSER

Cuber Model Numbers: CR-0690N
CD-0692N
CY-0694N

Condenser Model Number: AC-0695A

Precharged Line Model Numbers: RT-20, RT-35, RT-50, MRT-28

GENERAL INFORMATION

The cuber head sections listed above are used with the AC-0695A condenser and one of the four precharged line sets designated by the customer.

Note: The standard C-0600 self-contained cuber is not designed to be used with the AC-0695A remote condenser.

The CO-0690N Cubers and the AC-0695A Condenser are designed to be used with one of the RT-Line sets. Manitowoc cannot be responsible for improper operation if lines other than the RT-Sets are used and are of different diameter or over the 50 ft. maximum length. The precharged lines, cuber head and remote condenser are all shipped in separate crating.

The ICE making sections of the standard C-0600 and C-0690N Cubers are identical. See Figures 4 & 5 on pages 8 & 9.

****Cubers used with MRT-28 line set:** The MRT-28 line set is a special flexible line to be used in conjunction with cubers mounted on casters. This special line has an 8 foot section of braided flexible stainless steel to permit the cuber to be moved approximately 4 feet in any direction without damage to the precharged lines. This provides easy mobility for cleaning & servicing in back of cuber.

INSTALLATION See Fig. 8 For Additional Information

Cuber Set Up:

Follow the standard cuber instructions on pages 3 through 5, but do not place the cuber into its final position until the refrigerant lines and electrical lines to the remote condenser are connected.

REMOTE AIR CONDENSER SET-UP

1. Assemble two legs to each of the two mounting tracks. This assembly provides for two separate height adjustments. The standard 12 inch height and a 15 inch height to be used in installations where heavy snow or debris may collect at base of condenser causing air flow restrictions. See Figure 1.
2. Locate the remote condenser in a well ventilated area on the roof. Consult the Manitowoc office for other applications.
3. Using the six mounting holes provided, secure the remote condenser to the roof. Seal with tar or pitch to prevent entrance of moisture.

INSTALLING THE REFRIGERATION LINES

1. Each condenser is connected with two precharged lines. The precharged lines are ordered separately from the condenser to suit each individual application.
The precharged line lengths are 20 ft. (RT-20), 35 ft. (RT-35), 50 ft. (RT-50) and 28 ft. (MRT-28).
2. Remove the tubing from the carton. Carefully unwind the coil so the tubing doesn't become kinked.
3. The refrigerant fittings on the cuber and remote condenser are oiled at the factory. Additional lubrication should be used before assembly. Use Refrigeration Oil Only!
4. Note: The MRT-28 lines are provided with a 90° bend at one end. This end is intended to be attached to the cuber to provide a minimum 6 inch clearance between cuber and wall. If additional bends are required, slide armaflex away from tubing. Using a tube bender, carefully bend tubing to required angle.

5. Follow step (6) and connect one refrigerant line to fitting #1 on the cuber, and fitting #1 on the condenser. Connect the other line to fitting #2 on both the cuber and condenser. Fig. 9.
6. To connect the refrigerant lines to the cuber, remove the rear & right hand end panels on the cuber.
7. Carefully thread, by hand, the female hose fitting to the male fitting on the cuber and remote condenser. Using the proper size wrench, tighten the couplings until you feel them bottom out. Then add an additional $\frac{1}{4}$ turn to insure proper seal. If a torque wrench is used follow these for $\frac{1}{4}$ " to $\frac{3}{8}$ " fittings with $\frac{5}{16}$ -18 thread size, the torque value is 10-12 ft. lbs. For $\frac{1}{2}$ " fittings with 1-1/16"-12 thread size, the value is 35-45 ft. lbs.

Important: Once the refrigerant lines are connected, the seal is broken in the fittings and if removed from the cuber or remote condenser, the refrigerant charge in the cuber and condenser will be depleted.

WATER SUPPLY AND CONNECTIONS, See Page 4

ELECTRICAL HOOK-UP

	Voltage	Min. Circuit Amps	Max. Fuse Size
C-0690N	208/230 1PH	13.3 Amps	20 Amps

The electrical power supply is run through the standard opening at the rear of the cuber. The remote condenser electrical hook-up is connected to the cuber and condenser as shown in figures 8 & 9. There are 3 wires in the cuber electrical supply box labeled, L1, L2, & F1. The condenser motor has two leads, one should be connected to L2 and one to F1 in the supply box.

FIG. 8

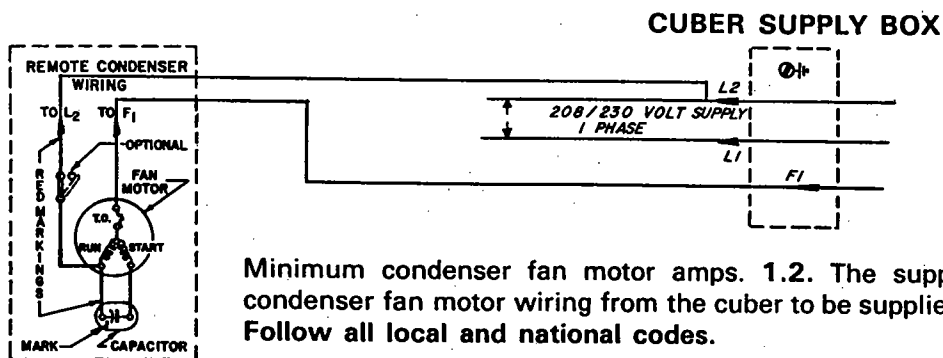

Minimum condenser fan motor amps. 1.2. The supply wiring and condenser fan motor wiring from the cuber to be supplied by customer. Follow all local and national codes.

SERVICE NOTE:

To insure proper operation in all ambient conditions, the refrigerant charge in a Manitowoc remote system must be at nameplate charge. New packages supplied by Manitowoc are precharged. Subsequent repairs to the sealed system must include a total purge, complete evacuation, and a measured charge. This service procedure requires connections at three points within the sealed system.

1. Receiver Service Valve — This evacuates the area between the head pressure control valve and the solenoids.
2. Suction Side at the Compressor or Low Side Service Port — This evacuates the suction side between the compressor and solenoid valves. Fig. 11 items 11. & 14.
3. Discharge Side at the High Side Service Port or the Quick Connect Service Port. This evacuates the high side between the compressor and the head pressure control.

FIG. 9

**INSTALLATION OF
C-0690N CUBER AND THE AC-0695A
REMOTE CONDENSER
WITH C-610 BIN**

UNDERWRITERS LABORATORIES FILE NO. SA4027
NATIONAL SANITATION FOUNDATION FILE NO. 595
CANADIAN STANDARD ASSOCIATION FILE NO. LR. 25608

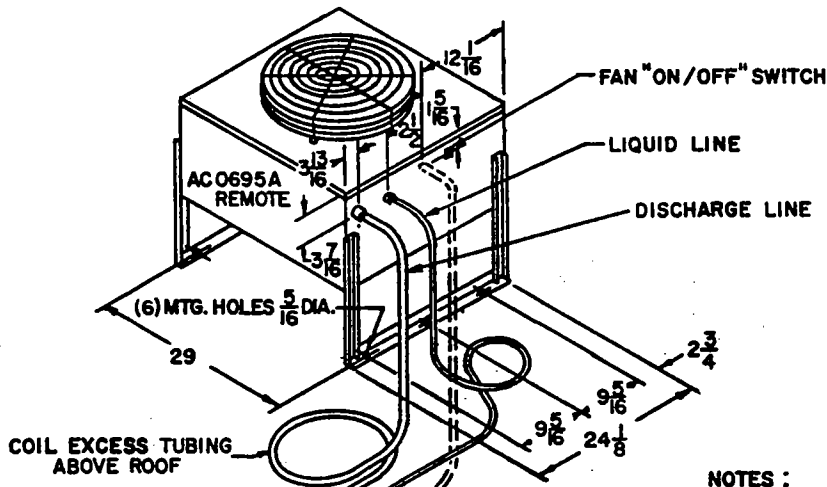

NOTES :

1. SUGGESTED INSTALLATION : ALLOW A MINIMUM OF 6 INCHES OF CLEARANCE ON BOTH SIDES AND IN BACK OF UNIT.
2. MINIMUM WATER INLET PRESSURE 25 LBS.
3. ALL WIRING AND PLUMBING MUST COMPLY WITH LOCAL AND NATIONAL CODES.

BORE 2 1/2 DIA. HOLE IN ROOF OR WALL 2" FOR TUBING. SEAL WITH TAR OR PITCH AND SLOPE TO PREVENT ENTRANCE OF MOISTURE.

(2) WIRE ELECT. INTERCONNECTION (BY CUSTOMER) WIRING MUST MEET ALL LOCAL & NATIONAL CODES. MIN. REQUIRED FAN MOTOR AMPS. 1.2 GROUND THROUGH CONDUIT OR 3rd WIRE TO GROUND SCREW.

ELECTRICAL SUPPLY
208 OR 230 V., 60 HZ., 1 PH
MINIMUM CIRCUIT AMPS. (13.3)
MAXIMUM FUSE SIZE (20)

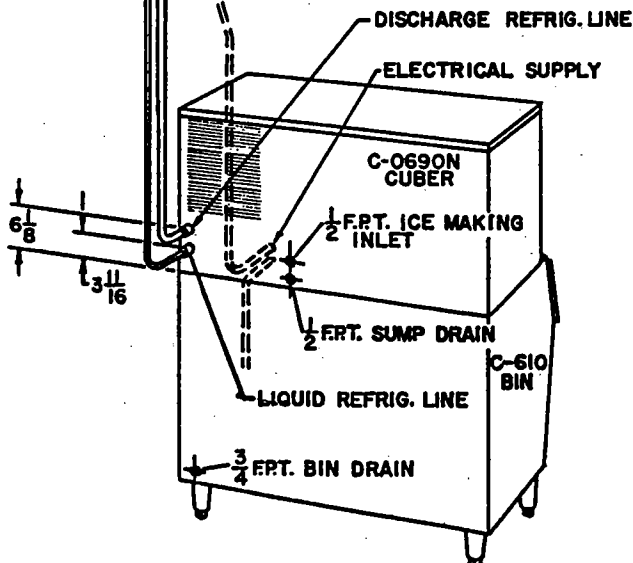

START-UP

The start-up procedure and check list for the remote cubers are the same as for the standard cubers. Pages 4 & 5, with the following additions.

1. Before start-up, open (backseat) the receiver valve.
2. After the cuber is running, check the remote air condenser & verify that the condenser fan is running. Fan will be off during the defrost cycle.

SYSTEM CONTROL AND SEQUENCE OF OPERATION

The main on-off toggle switch for the cuber is located on the control box. Fig. 4. The toggle switch has three positions; the center or "off" position, the "water pump" position (only the water pump operates) and the "ice" position.

SEQUENCE I FREEZE CYCLE

FREEZE CYCLE — Sequence I

Placing the toggle switch in the "ice" position will energize the liquid line solenoid valve and the water pump and condenser fan motor through terminals 4 & 5 on the timer. This will allow the suction or low side pressure to rise. When the low side pressure reaches approximately 25 PSIG, the low pressure cut-out control will close its contacts, energizing the compressor. The cuber is now in freeze cycle. As water flows over the evaporator, the ice will begin to form.

As the ice cubes form, the suction or low side pressure will continually decrease. At a present point the low pressure cut-in control will close its contacts. 10½ PSIG regular and dice cube size and 11 PSIG half dice cube size.

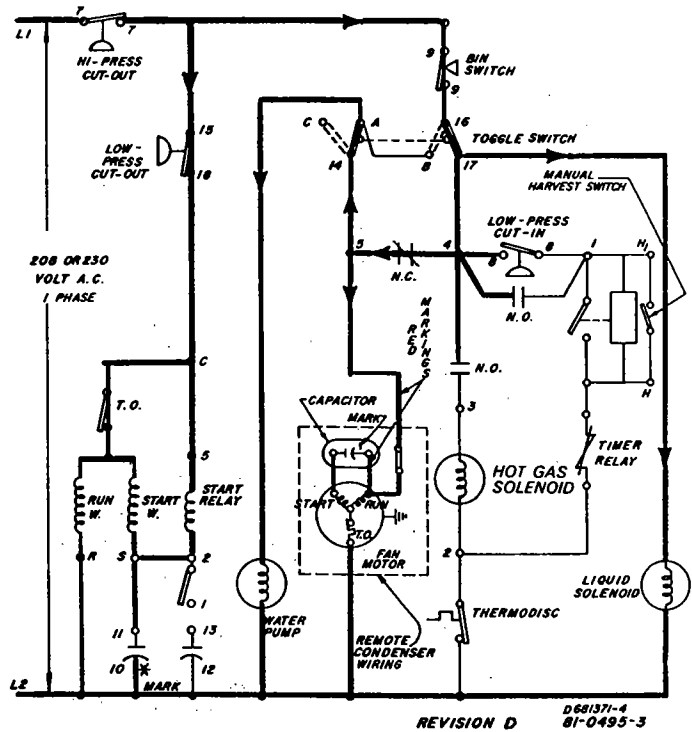

SEQUENCE II FREEZE CYCLE WITH TIMER ENERGIZED

Sequence II

Closing of the low pressure cut-in control contacts will energize the time delay circuit of the solid state timer through terminal 1. The remaining freeze time is dependent upon the timer setting.

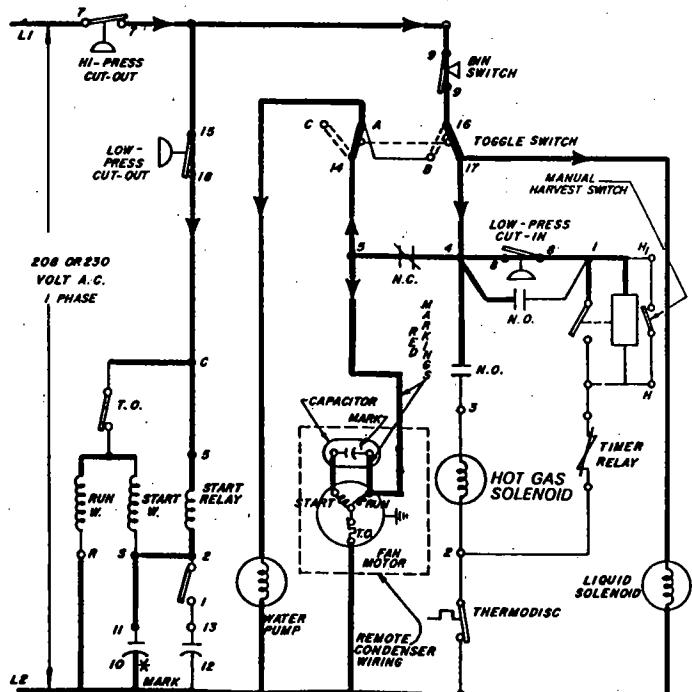

**SEQUENCE III BEGINNING OF HARVEST CYCLE
WITH LOW PRESSURE CONTROL
STILL CLOSED**

Sequence III

At the end of the timing sequence, the timer relay will energize. This will open the relay contacts between terminals 4 & 5 shutting off the condenser fan motor and water pump and close the relay contacts between terminals 3 & 4 energizing the hot gas solenoid valve. The cuber is now in the harvest cycle. Shortly after the hot gas solenoid valve opens the low pressure cut-in control contacts will re-open.

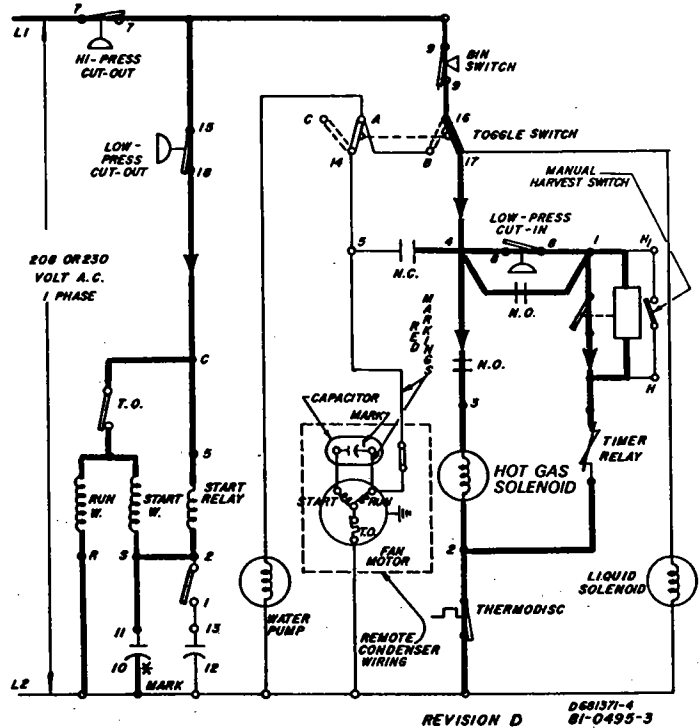

**SEQUENCE IV HARVEST CYCLE WITH
LOW PRESSURE CONTROL
OPEN**

Sequence IV

Note: To manually place the cuber in harvest, see timer description and check-out procedure, page 21.

As the harvest cycle progresses, the hot gas will warm the evaporator releasing the ice. The ice will fall through the ice chute, opening the damper door that is mounted in the chute. (Fig. 4) As the damper door is pushed open, it will trip the damper door (bin) micro switch, momentarily de-energizing the timer and liquid solenoid valve. The timer relay will return to its normal position, de-energizing the water pump and condenser fan motor. The cuber is now in a new freeze cycle.

The ice cuber will continue to cycle in this manner until the storage bin is full. The ice cuber automatically discontinues ice production as the ice fills the chute, holding the damper door and bin micro switch open.

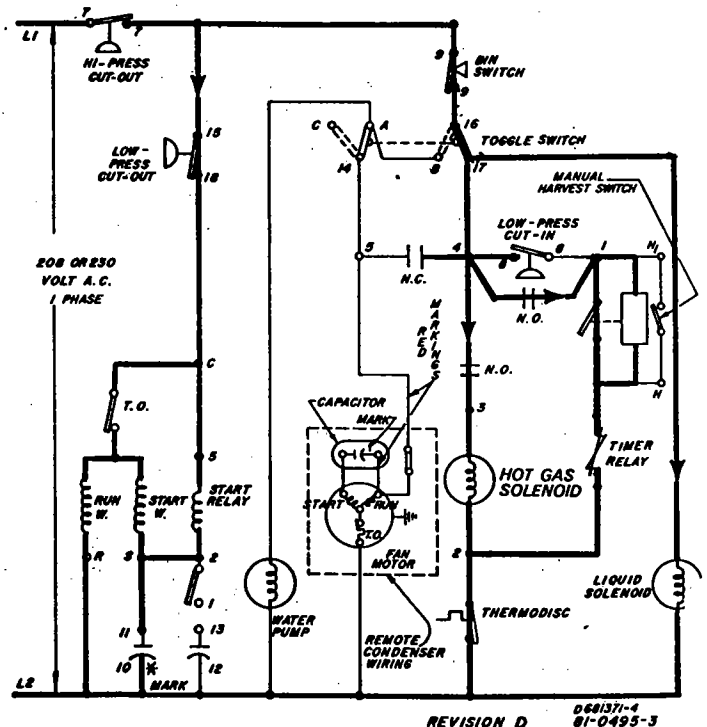

SEQUENCE V TOGGLE SWITCH IN WATER PUMP POSITION

Sequence V

Opening the bin micro switch or placing the toggle switch in the "off" position will de-energize the liquid line solenoid valve. The system will begin to pump down the low side. When the suction or low side pressure reaches 2 PSIG, the low pressure cut-out control will open, de-energizing the compressor.

Within the electrical system there are two safety controls to protect the cuber, the suction line thermodisc and the high pressure cut-out.

If the bin switch would fail when the ice falls through the ice chute, the cuber would remain in the harvest cycle until the suction temperature reached $70^{\circ} \text{F} \pm 5^{\circ}$. At this time the safety thermodisc, located on the suction line, would open its contacts, de-energizing the timer relay and hot gas solenoid valve, placing the cuber back into the freeze cycle. As the evaporator begins to cool, the thermodisc will reclose its contacts at $40^{\circ} \text{F} \pm 5^{\circ}$.

The high pressure cut-out control will shut the entire cuber off should the condensing or head pressure become too high.

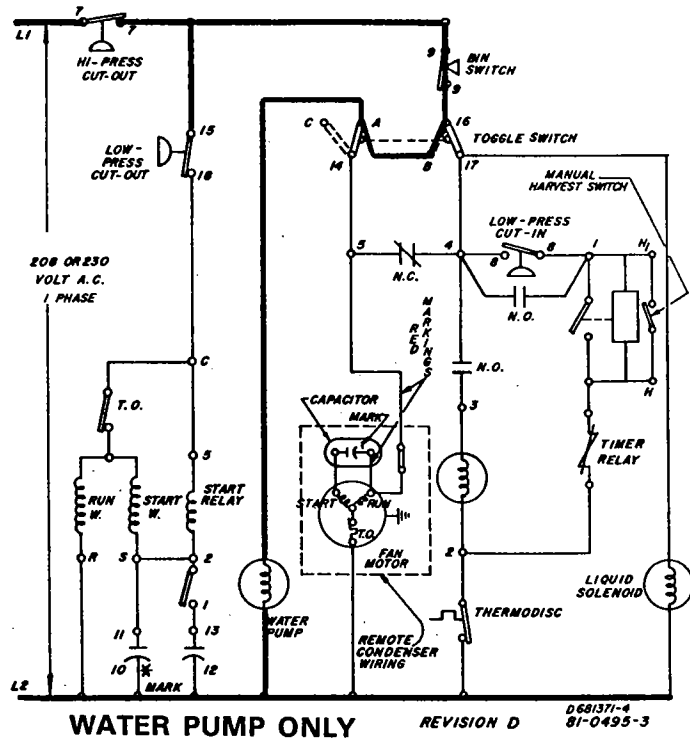

SEQUENCE VI CUBER OFF ON TOGGLE SWITCH, HIGH PRESSURE CUT-OUT OR LOW PRESSURE CUT-OUT.

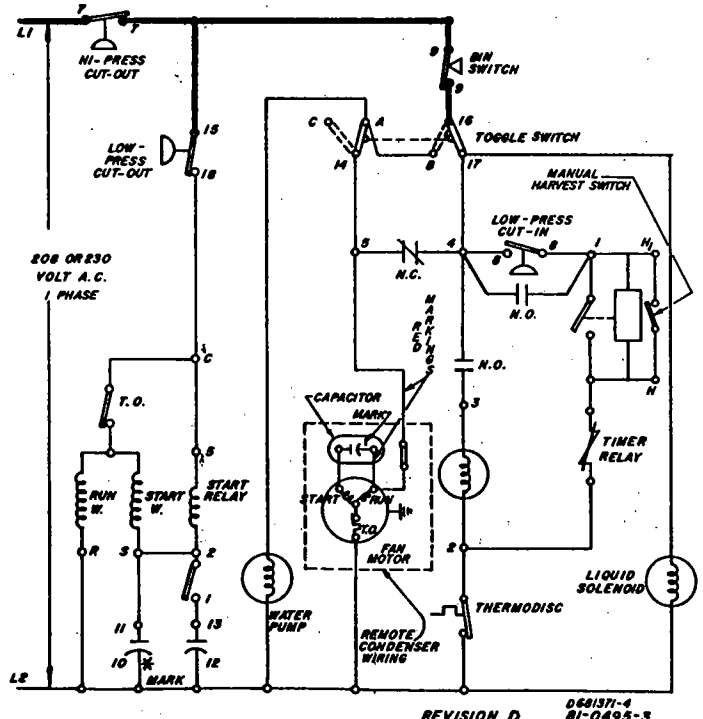

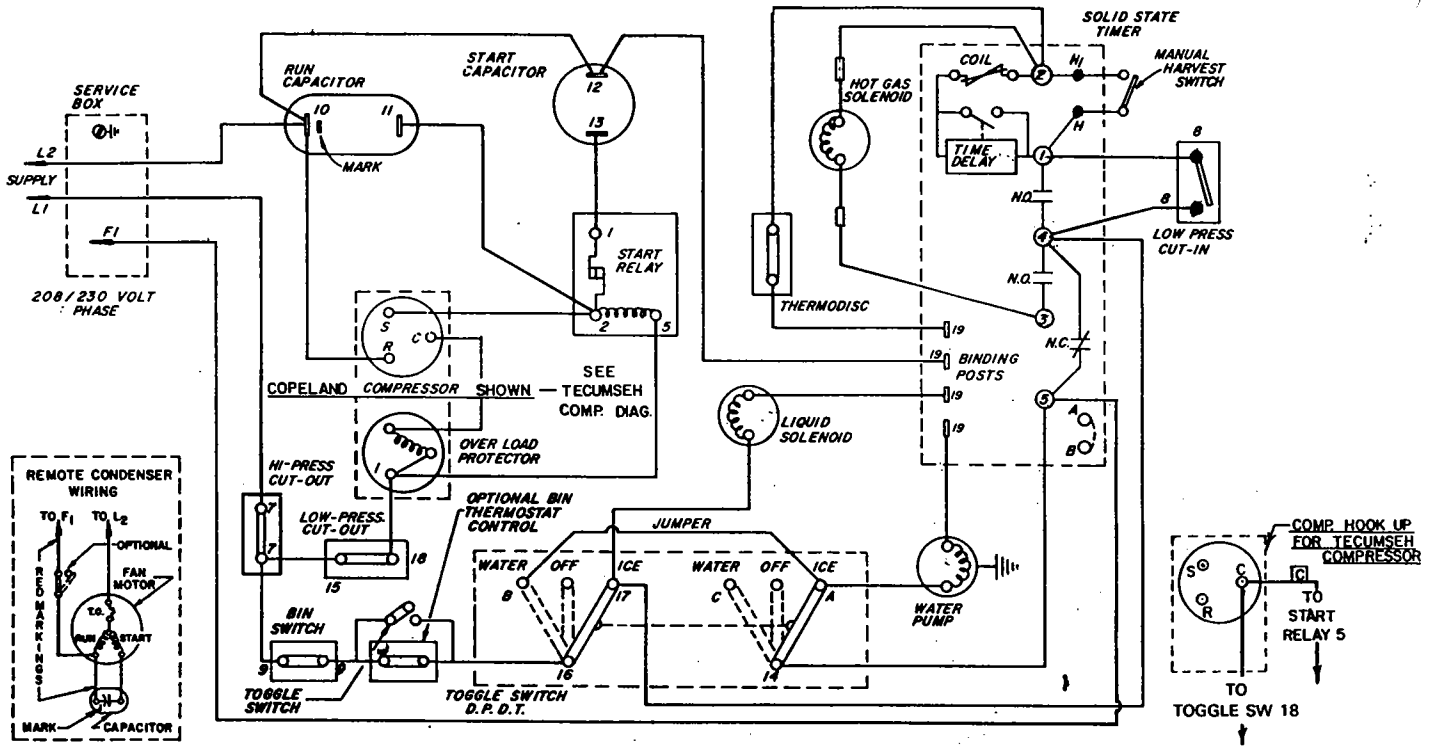

WIRING DIAGRAM C0690N CUBER W/REMOTE CONDENSER
 208/230 VOLT, 60Hz, 1PHASE or 230 VOLT, 50Hz 1 PHASE
 SHOWN AT BEGINNING OF FREEZE CYCLE

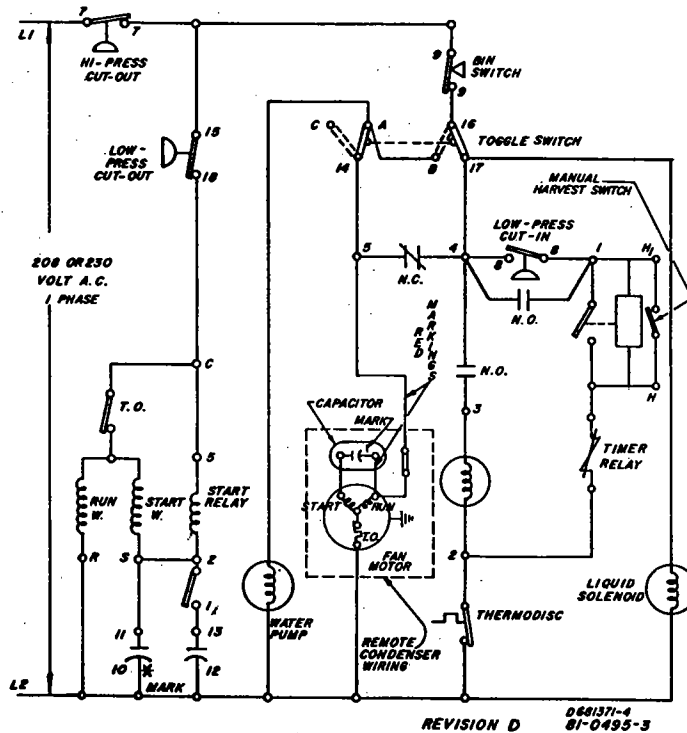

REVISION D 0881371-4 81-0493-3

REFRIGERATION CYCLE — C0690N Cuber with AC-0695A Remote Condenser (Fig. 10)**Freeze Cycle**

During the freeze cycle the high pressure discharge gas is pumped into the remote condenser. The high pressure gas is condensed into a high pressure liquid. The high pressure liquid leaves the condenser and goes through the head pressure control valve to the receiver.

The purpose of the head pressure control valve is to maintain a minimum receiver head pressure of 90-100 PSIG for normal system operation. Because of the pressure drop this minimum pressure will be approximately 10-15 PSIG higher at the compressor discharge valve.

During colder weather this control will gradually flood the condenser and start by-passing hot gas to the receiver to maintain the 90-100 PSIG receiver head. An under charge will cause problems during cold weather (70° F. and below) and will show up in poor defrosting and premature energizing of the low pressure cut-in.

During hot weather (80° F. and above) the receiver will be $\frac{1}{2}$ to $\frac{3}{4}$ full of liquid refrigerant. An overcharge can cause problems in hot weather when the refrigerant charge is more than the receiver can hold.

The high pressure liquid leaves the receiver and goes through the heat exchanger reducing the liquid temperature making the system more efficient. The high pressure liquid is then metered into the evaporator by a thermostatic expansion valve. The expansion valve regulates the rate of refrigerant liquid flow into the evaporator in the exact proportion to the rate of evaporation of the refrigerant liquid in the evaporator. The expansion valve does this by responding to (1) the pressure in the evaporator (2) the temperature of the refrigerant gas leaving the evaporator using the valve feeler bulb to sense the gas temperature.

After the low pressure liquid evaporates to a low pressure gas, it passes through the suction line heat exchanger and into the compressor. The ave. suction pressure will start at approx. 18 PSIG and drop to approx. 5-7 PSIG when the cuber goes into harvest.

HARVEST CYCLE

The harvest is initiated by the solid state timer energizing the solenoid valve allowing high pressure hot gas to flow through the evaporator and harvest the ice. The suction pressure during the harvest is approx. 40-60 PSIG. The head pressure will drop to approx. 70-100 PSIG.

When the hot gas solenoid valve opens, the head pressure will drop below the 100 PSIG minimum and the pressure drop across the head pressure control will be over 30 PSIG. This will cause the head pressure control valve to stop the liquid flow from the condenser and by-pass hot gas to the hot gas solenoid valve. The cuber goes back into the freeze cycle automatically when the solenoid valve is closed by the harvesting ice tripping the bin switch.

The cuber is now in a new freeze cycle.

C-0690N CUBER WITH AC-0695A REMOTE CONDENSER OPERATING CHARACTERISTICS

	AIR TEMP.	FREEZE CYCLE	HARVEST CYCLE
HEAD PSIG	70	130-100	70-90
	80	140-100	70-95
	90	145-110	75-100
	100	160-125	90-110
SUCTION PSIG	70	18-6	40-50
	80	20-8	40-50
	90	21-8	50-60
	100	22-9	55-65

*These are approx. characteristics that vary depending on operating conditions.

FIG. 10
REFRIGERATION SCHEMATIC
600 SERIES WITH REMOTE
AIR COOLED CONDENSER

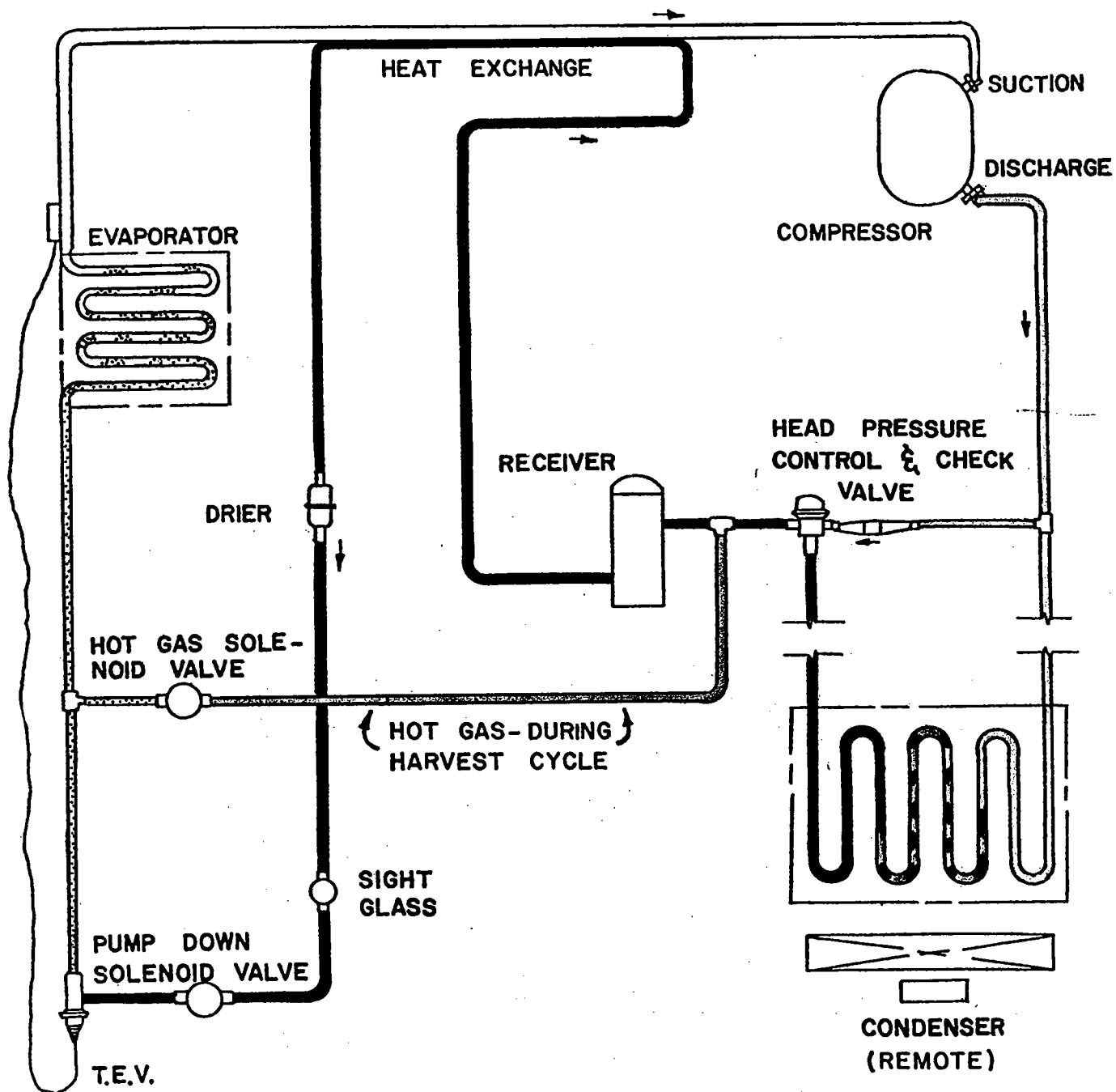





-  HIGH PRESSURE GAS
-  HIGH PRESSURE LIQUID
-  LOW PRESSURE LIQUID
-  LOW PRESSURE GAS

FIG. 11
CO-0690N REMOTE CUBER COMPRESSOR COMPARTMENT

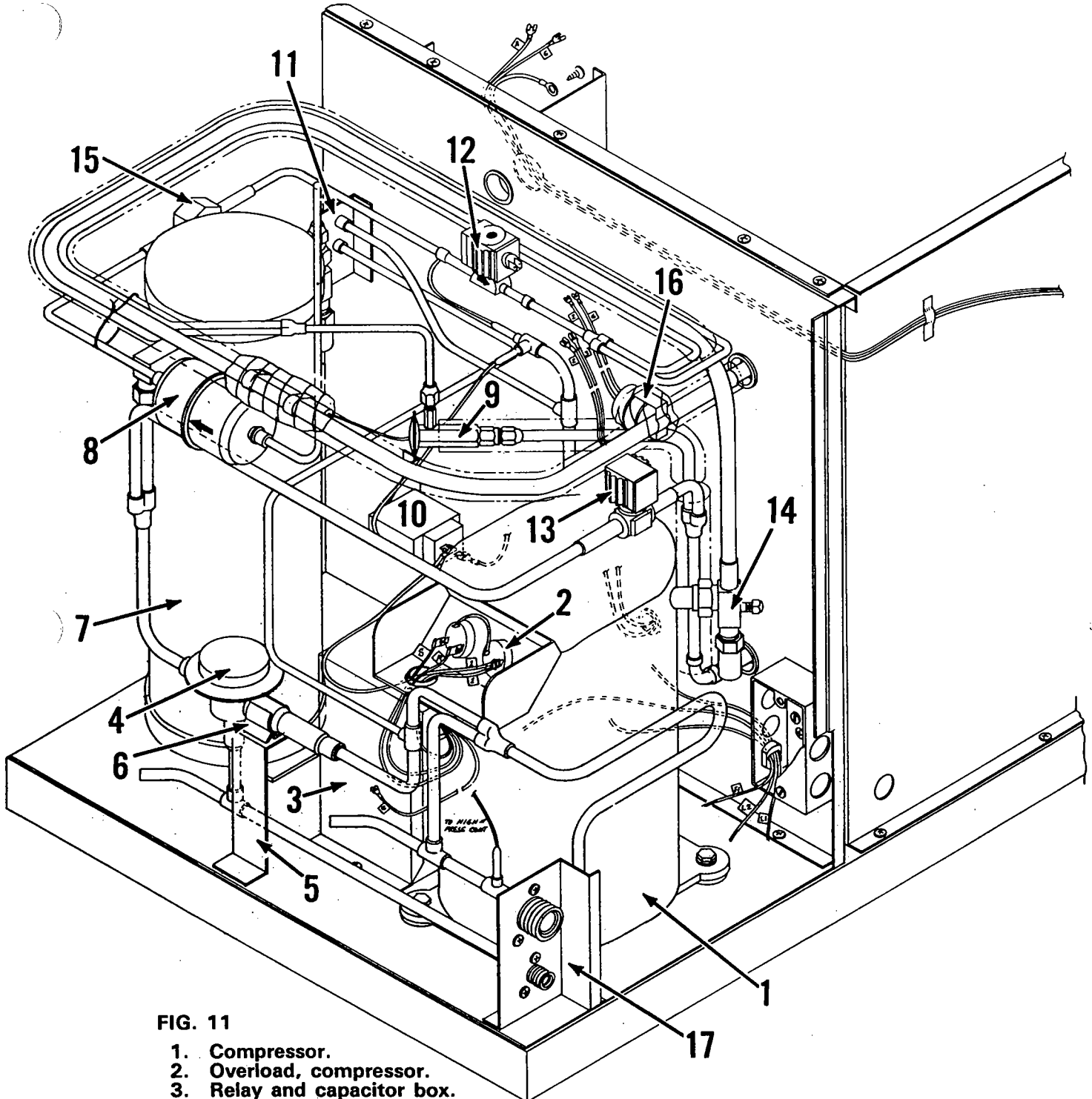

FIG. 11

1. Compressor.
2. Overload, compressor.
3. Relay and capacitor box.
4. Head pressure regulator.
5. Mounting bracket for item 4. (No longer used)
6. Mounting clip for item 4. (No longer used)
7. Receiver.
8. Drier.
9. Expansion valve.
10. Low pressure cut-out.
11. Service ports.
12. Pump down solenoid valve.
13. Hot gas solenoid valve.
14. Suction service valve.
15. Sight glass.
16. Thermodisc.
17. Condenser lines quick connect fittings.

GENERAL SYSTEM SERVICE ANALYSIS

<u>COMPLAINT</u>	<u>CAUSE</u>	<u>CORRECTIVE MEASURE</u>
Cuber will not run	Toggle switch in neutral position	Turn switch to Ice-making position.
	Compressor or starting components defective	See compressor check procedure.
	Toggle switch defective	See toggle switch check procedure.
	High pressure cut-out tripped	Reset & check system.
	Blown fuse or power off	Replace fuse, check main switch
	Bin switch open	Bend switch arm for proper action, Check free movement of damper door. See bin switch check procedure.
	(Remote Head) liquid solenoid not opening.	Replace coil or complete valve assembly
	Low pressure cut-out	Re-calibrate or replace.
	Control not set properly	(See Low Pressure cut-out (check procedure)
	Cuber does not harvest or slow harvest	Low pressure control not closing
Leaking cond. water valve (water cooled)		Replace water valve.
Solid state timer defective, not energizing		See S.S. timer check procedure.
Safety thermodisc defective or loose on suction line		See safety thermodisc check procedure.
Leaky hot gas valve during freeze cycle		Replace valve.
Ice bridge too thin, cubes should fall as sheet		Adjust time up to increase bridge thickness.
Defrost solenoid coil defective		Replace solenoid coil or valve.
Suction pressure doesn't drop properly		
a. Defective expansion valve		Replace expansion valve.
b. Leaky hot gas solenoid valve		Replace valve.
c. Expansion valve bulb loose		Tighten & insulate to suction line.
Harvest rack bent-up restricting harvest		Bend center of rack down.
Contaminated or limed water system, evaporator suction release holes plugged		Clean evaporator and water system.
Low ambient (air cooled cubers)		Ambient temperature must be above 55°.
Cond. water valve set too low (water cooled)		Set water valve to 125 PSIG head.
(Remote Cuber) Low Head Pressure during freeze cycle, min. 100 PSIG — low on refrigerant charge	measure in correct amount listed on name plate.	
— head pressure control valve not by-passing hot gas	Replace	

<u>COMPLAINT</u>	<u>CAUSE</u>	<u>CORRECTIVE MEASURE</u>
Ice shells instead of cubes or bridging too small	Timer out of adjustment Low pressure cut-in control not opening Low refr. charge, leak in system	See check procedure. Check control, replace if defective. Locate leak, repair, evacuate & recharge if necessary. See major maintenance.
Irregular size cubes & some cubes cloudy	Holes in water distributor plugged Shortage of water Distributor not in proper location	Clean distributor. Check pump & water level in sump. Adjust.
Too large cube bridge	Timer set too high — Low pressure cut-in set too low	See timer check procedure. See L.P. cut-in check procedure.
Low ice capacity	Sump overflow elbow out of position Defective Expansion Valve Sump water overflowing elbow during freeze cycle Float stuck in open position Water strainer dirty Leaky hot gas valve Inefficient compressor	Adjust elbow. Replace. Adjust float to maintain water level approx. 1/4" of flush elbow. Adjust until float moves freely. Remove & clean mesh screen. Check and replace if necessary. Check & replace if necessary.
High head pressure	High head pressure Fan motor or fan cycle switch defective Condenser water valve defective or not adjusted properly Dirty condenser Inadequate water supply (water cooled) Defective exp. valve Too hot cuber location with poor air circulation Air in refrig. system Overcharge of refrigerant	See high head pressure. Replace, see check procedure. Replace water valve or adjust to 125 PSIG head. Clean condenser, see cleaning instructions. Check supply line & water valve. Replace if considered necessary. Relocate or provide ventilation to area. Evacuate and recharge, see major maintenance. Correct charge.
(Remote Cuber)	Overcharge of refrigerant Head press. control valve malfunctioning, by passing hot gas when not needed	Remove charge & measure correct amount in. Replace.

<u>COMPLAINT</u>	<u>CAUSE</u>	<u>CORRECTIVE MEASURE</u>
Low head pressure (Remote Cuber)	Ambient temp. below 55° F	Heat area or install low ambient fan switch.
	Undercharge of refrigerant	Leak Check. Remove charge & measure correct amount in.
	Head pressure valve not functioning	Replace

CLEANING INSTRUCTIONS

IN PLACE CLEANING

To clean the ice cuber water system without removing the components proceed as follows. NOTE — This is only recommended in locations where impurity build-up is not heavy.

1. Remove ice cuber front panel.
2. Shut off ice cuber.
3. Remove ice from bin.
4. Shut off water supply and remove water from water sump.
5. Pour the recommended amount of ice machine cleaner into sump and turn water supply on.
6. Place toggle switch to water pump position and circulate cleaner for about 30 minutes.
7. After cleaning, shut machine off and remove cleaner. Flush water system thoroughly.
8. Clean ice storage bin with ice machine cleaner also.

DISASSEMBLING WATER SYSTEM FOR CLEANING

To clean parts by removing proceed as follows:

1. Shut machine off.
2. Remove splash curtain, water pump and water distributor.
3. Disassemble distributor.
4. Disassemble water pump as follows:
 - A. Turn pump over and remove the water inlet screen. See Fig. 7.
 - B. Hold and depress impeller. Rotate plastic thumb nut counter-clockwise.
 - C. Remove screws and pump housing. Pump is now ready for cleaning.
 - D. Reassemble in reverse order as removed.
5. Inspect weep holes located in the corners of each cube section, using a brush to remove any scale build-up.

Scrub all parts using a nylon scouring pad, brushes, and cleaning solution such as LIME-A-WAY from Economics Laboratory, Inc., or Boss Brand Milk Stone Cleaner from Northern Laboratories. Rinse all parts with clear water.

It is recommended that the ice be removed from the storage bin before scrubbing the base and evaporator assembly. Rinse with clear water. Check to see that overflow or drain hole in the base is clear and that water drains through freely.

Reassemble unit. To sanitize unit, mix ONE TEASPOON OF SODIUM HYPOCHLORITE (CHLORINE BLEACH) IN ONE GALLON OF WATER. Pour solution into sump, then turn toggle switch to the left to start water pump.

Keep pouring solution into sump until system has enough to keep pump primed. After one minute turn off pump and remove solution from water sump. Repeat with clear water before turning switch back to the ice making position. Make visual inspection for leaks and operation before replacing the front panel.

SERVICE AND PARTS PROCEDURES

ORDER AND PRICING PROCEDURE

replacement parts for Manitowoc ice machine equipment should be ordered directly from your local Manitowoc Ice Machine distributor. Parts are stocked by the distributor in order to provide prompt and efficient service for ice machines sold in their areas.

Should you encounter difficulty in locating a Manitowoc distributor in your area, contact Manitowoc Service Parts Dept. for the name or names of distributors in your area.

When placing your order, be sure to do as follows:

1. Print name and address plainly.
2. If special routing is requested, please show the name of the carrier.
3. Indicate quantity desired, print catalogue part number plainly and print name as shown in the catalogue.
4. Indicate model and serial number of the unit. The complete serial number is needed.
5. If uncertain as to the proper part number, please give a complete description or sketch of the part and the location of the part which is needed.
6. Check to see that all required information is contained in your order to facilitate prompt shipment from the factory on a f.o.b. Manitowoc basis. It is company policy to bill for all field replacement parts, according to terms as specified by our Credit Department.

All parts orders will be honored by the factory and will be billed according to our parts lists schedules.

Parts which are covered by our warranty policy are to be returned to the factory for credit, transportation charges prepaid. Upon receipt of these parts here at the factory, they will be inspected; and if they are found to be defective, in material and workmanship, under normal use and service, credit will be issued.

Transportation companies are responsible for damages in transit as all shipments are tendered to them in good condition; and our responsibility ceases upon receipt of a signed bill of lading from the carrier. If the shipment arrives in a damaged condition or is short, the delivery carrier should be notified immediately.

RETURN OF DEFECTIVE PARTS

All defective parts returned to the factory, transportation prepaid, must be tagged with a return material tag properly filled in. It is especially important that the cabinet serial number be secured and recorded on the tag, securing as much information as possible about the nature of the defect to prevent any delays in issuing credit. All parts should be returned as they are removed from the cabinet and not mutilated or tampered with. The return material tags are provided on a no-charge basis by the factory upon receipt of your request.

Our warranty and protection plan does not apply to cabinets that are not registered; therefore, it is necessary that, upon completion of the installation of the cabinet, the registration card be signed on the date of installation and mailed promptly to the factory Service Department in order for the cabinet to be registered.

RETURN OF HERMETICALLY-SEALED UNITS

Extreme care should be used in servicing the hermetically-sealed mechanism. It is important that the trouble be correctly determined before the unit is changed. Be sure it is not the control, relay, or overload causing the trouble. The defect must be listed on the return material tag.

RETURN OF COMPLETE MACHINES

No complete machines may be shipped back to the factory for repairs without first securing prior permission from the factory. If an unauthorized shipment is received at the factory, it will be refused by our warehouse and immediately returned to the sender. Upon receipt of your request to return a cabinet, if we feel that your request is legitimate, you will be sent an authorized return label authorizing you to return this cabinet to the factory freight prepaid. On water cooled models, water lines and condenser must be completely drained and blown out before returning.

SERVICE AND LABOR CHARGES

In accordance with our warranty and protection plan, which is included in each cabinet, this protection plan provided is available only through distributors and dealers who will be solely responsible for service and labor charges.

SERIAL NUMBER NOMENCLATURE (Located On Nameplate)

USED IN 1979

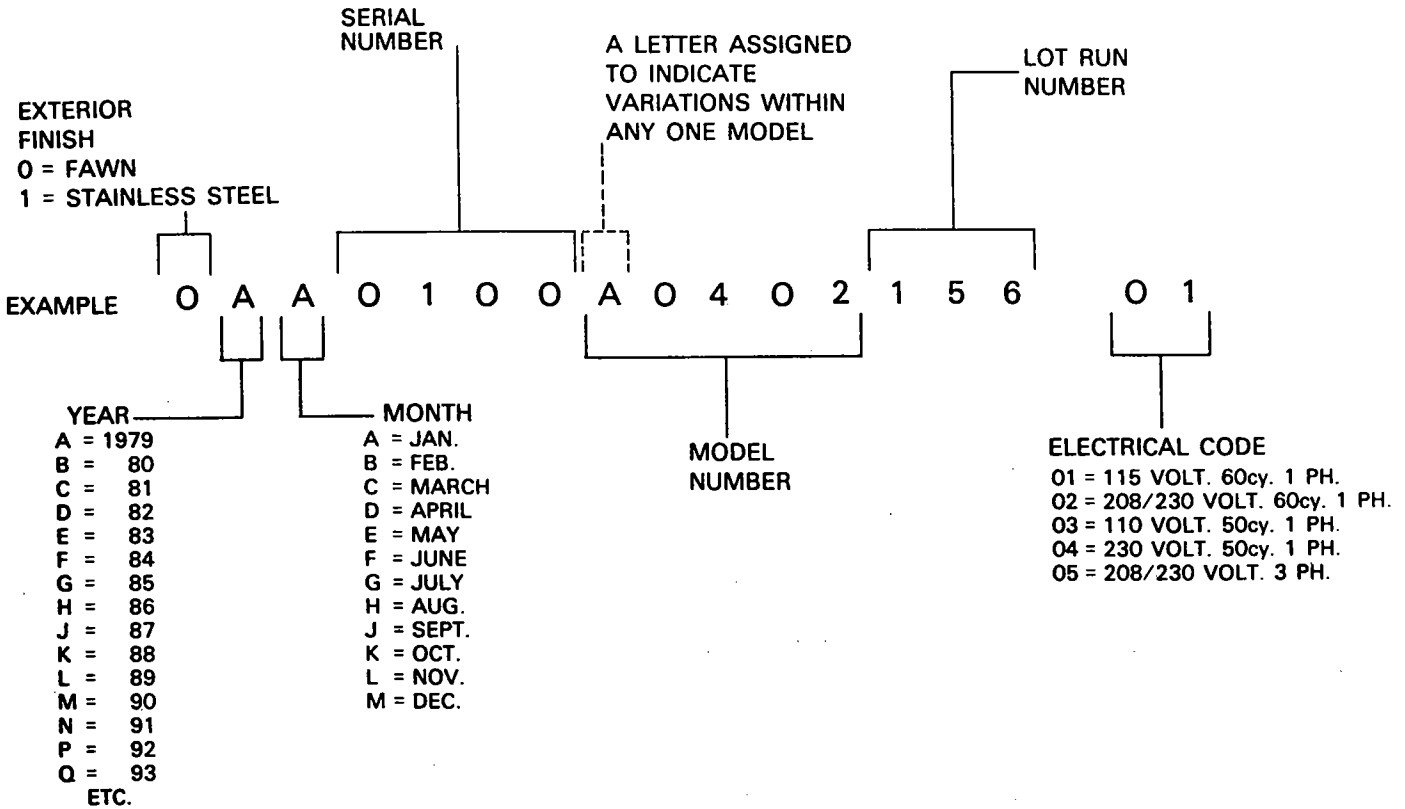

STARTED USING IN 1980

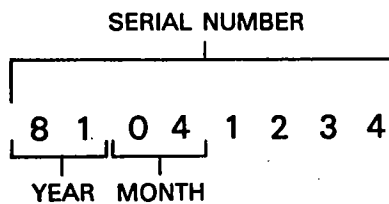

The 8 digit serial number has a built-in production date code. The first 2 digits indicate the year and the second 2 digits indicate the month.

Always use the entire 8 digit serial number and model number when identifying the unit.

Ice Machine and Bin Warranty

From the date of original installation, we do hereby warrant each new Ice Machine and Bin to be free from defects in material and workmanship, under normal use and service, for a period of one year, and four additional years on the hermetic motor compressor in the Ice Machine.

Our obligation under this warranty is limited solely to correcting or replacing without charge at the factory in Manitowoc, Wisconsin any part or parts of this equipment which shall have been returned, transportation prepaid, and which our examination discloses to our satisfaction to be defective.

This warranty does not apply to any equipment that has been damaged by flood, fire, or suffered abuse, misuse, neglect or accident, or to any Ice Machine which has been altered so as to affect performance or reliability, except where such alteration has been accomplished with our prior written consent.

We further limit this warranty in that we shall not be held liable under this contract for any special, indirect, or consequential damages whatsoever resulting from any defect in material and workmanship which interferes with the normal use and service of such Ice Machine and Bin.

This warranty is a complete and exclusive statement of all terms of the agreement between the Manitowoc Equipment Works and the owner of the equipment, and all representations of the parties. This agreement shall not be varied, supplemented, qualified or interpreted by any prior course of dealing between the parties or by any usage of the trade.

Sales are made on the express understanding that there are no express or implied warranties other than the express warranty herein contained and that there are no implied warranties that the goods shall be merchantable or fit for a particular purpose other than the expressed one year and five year warranty set forth above.

To validate this warranty, the registration card must be signed on the date of installation and mailed promptly to the Manitowoc Equipment Works, Manitowoc, Wisconsin.

DEALER _____

INSTALLATION DATE _____

MANITOWOC EQUIPMENT WORKS
(A division of The Manitowoc Co., Inc.)
2110 South 26th St., Ph: 414-682-0161
Manitowoc, Wisconsin 54220

Ice Machine and Bin Warranty

From the date of original installation, we do hereby warrant each new Ice Machine and Bin to be free from defects in material and workmanship, under normal use and service, for a period of one year, and four additional years on the hermetic motor compressor in the Ice Machine.

Our obligation under this warranty is limited solely to correcting or replacing without charge at the factory in Manitowoc, Wisconsin any part or parts of this equipment which shall have been returned, transportation prepaid, and which our examination discloses to our satisfaction to be defective.

This warranty does not apply to any equipment that has been damaged by flood, fire, or suffered abuse, misuse, neglect or accident, or to any Ice Machine which has been altered so as to affect performance or reliability, except where such alteration has been accomplished with our prior written consent.

We further limit this warranty in that we shall not be held liable under this contract for any special, indirect, or consequential damages whatsoever resulting from any defect in material and workmanship which interferes with the normal use and service of such Ice Machine and Bin.

This warranty is a complete and exclusive statement of all terms of the agreement between the Manitowoc Equipment Works and the owner of the equipment, and all representations of the parties. This agreement shall not be varied, supplemented, qualified or interpreted by any prior course of dealing between the parties or by any usage of the trade.

Sales are made on the express understanding that there are no express or implied warranties other than the express warranty herein contained and that there are no implied warranties that the goods shall be merchantable or fit for a particular purpose other than the expressed one year and five year warranty set forth above.

To validate this warranty, the registration card must be signed on the date of installation and mailed promptly to the Manitowoc Equipment Works, Manitowoc, Wisconsin.

DEALER _____

INSTALLATION DATE _____

MANITOWOC EQUIPMENT WORKS
(A division of The Manitowoc Co., Inc.)
2110 South 26th St., Ph: 414-682-0161
Manitowoc, Wisconsin 54220

