



Manitowoc[®]

ICE MACHINES

**Series
G600**

SERVICE MANUAL

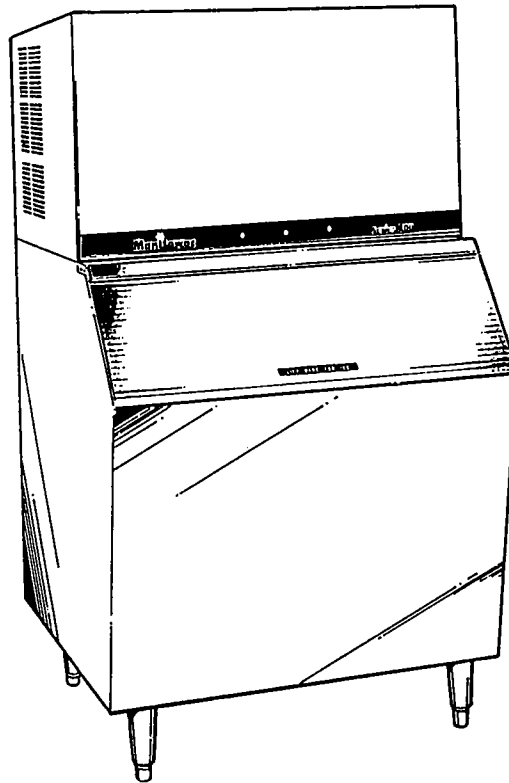

G6SVCVR

This product qualifies for the following listings:



We reserve the right to make product improvements at any time. Specifications and design are subject to change without notice.



Part No. 80-0844-3
Rev. 2 (1-97)



TABLE OF CONTENTS

GENERAL SPECIFICATIONS	1
WARRANTY INFORMATION	2
DIMENSIONS	4
COMPONENT IDENTIFICATION	8
Water Distribution Group and Outer Panels	8
Control Box Assembly	9
Compressor Start Components Electrical Box	10
Compressor Compartment (Air-Cooled)	11
Compressor Compartment (Water-Cooled)	12
Compressor Compartment (Remote Condenser)	13
INTERIOR CLEANING	14
Removal of Parts for Cleaning	14
Remove Water Pump	14
Remove Float Valve	15
Remove Distribution Tube	15
Disassemble Distribution Tube	15
Remove Ice Thickness Probe	16
Remove Water Trough	16
Cleaning Procedures	16
Cleaning the Evaporator	17
SANITIZING	18
CHECKING AND CLEANING THE WATER DUMP VALVE	19
Operation Check	19
Remove Water Dump Valve	19
Disassemble Plastic Body Water Dump Valve	19
Disassemble Brass Body Water Dump Valve	20
Cleaning Water Dump Valve	20
SEQUENCE OF OPERATION	21
Freeze Cycle (Self-Contained Air or Water Cooled) (Prechill of Evaporator)	21
Freeze Cycle (Self-Contained Air or Water Cooled)	23
Harvest Cycle (Self-Contained Air or Water Cooled)	25
Automatic Shut-Off (Self-Contained Air or Water Cooled) (Full Bin of Ice)	27
SEQUENCE OF OPERATION — REMOTE ICE MACHINES	28
Freeze Cycle (Prechill of Evaporator)	28
Freeze Cycle (Remote Machines)	30
Harvest Cycle (Remote Machines)	32
Automatic Shut-Off (Remote Machines) (Full Bin of Ice)	34
Auto Restart	34
Automatic Shut-Off (Remote Machines) (Refrigeration Sequence)	35
Automatic Shut-Off Water Flow Sequence	35
SERVICE DIAGNOSTIC CHART	36
COMPONENT FUNCTION, SPECIFICATIONS AND CHECK PROCEDURES	38
Bin Switch	38
Fan Cycle Control (Self-Contained Air-Cooled Models)	38
Float Valve	39
High Pressure Cut-Out Control — H.P.C.O.	39
Ice Thickness Probe	40
ICE/OFF/WATER PUMP Toggle Switch	40
Water Curtain	41
Water Pump	41
Water Pump Delay Timer	42
7-Second Delay Timer (Self-Contained Air or Water Cooled)	43

Low Pressure Cut-Out Control (Remote Machines)	44
Harvest Pressure Limiter Control	44
ELECTRONIC CONTROL CIRCUITRY	45
DIAGNOSING ELECTRONIC CONTROL CIRCUITRY	46
Ice Machine Will Not Go Into Harvest	46
Ice Machine Prematurely Goes Into Harvest without Ice Formation	48
DIAGNOSING COMPRESSOR AND START COMPONENTS ELECTRICALLY	49
REFRIGERATION AND OTHER NON-ELECTRICAL PROBLEMS	51
Introduction to the Six-Step Diagnostic Procedure	51
Step 1 — Visual Inspection	52
Step 2 — Ice Production	53
Step 3 — Ice Fill Pattern	54
Step 4 — Water System	54
Step 5 — Refrigeration	55
Step 6 — Final Analysis	61
Headmaster Control Valve (Remote Machines)	63
HOW TO USE MANIFOLD GAUGES	64
TXV INSTALLATION	65
ALCO REFRIGERATION SOLENOID VALVES REPLACEMENTS	66
LEAK CHECKING CONDENSER AND WATER REGULATING VALVE	67
REMOVAL FROM SERVICE/WINTERIZATION	68
EVACUATION AND RECHARGING	69
Removal of Refrigerant	69
Evacuation and Recharging of Self-Contained Systems	69
Evacuation and Recharging of Remote Systems	71
SEVERE SYSTEM CONTAMINATION	73
General	73
Determining Severity of Contamination and Clean-Up Procedures	73
Mild System Contamination Clean-Up Procedures	74
Severe System Contamination Clean-Up Procedures	74

MANITOWOC ICE, INC.

2110 South 26th Street P.O. Box 1720 Manitowoc, WI 54221-1720

Phone: (920) 682-0161

Fax: (920) 683-7585

Web Site: www.manitowocice.com

GENERAL SPECIFICATIONS

This section is not intended to be a guideline to install the ice machine. Refer to Installation Manual for installation procedures.

Ambient Air Temperature: 35°F minimum, 110°F maximum (minimum five-inch clearance rear and sides)

Ice Making Water Supply:

Pressure — 20 psi minimum, 80 psi maximum
 Supply Line — 3/8 inch
 Drain Line — 1/2 inch
 Water Temperature — 33°F minimum, 90°F maximum

Water-Cooled Condenser Water Supply:

Water Regulating Valve Setting — 220 psi ± 5 (Factory preset)
 Pressure — 20 psi minimum, 150 psi maximum
 Supply Line — 1/2 inch
 Drain Line — 1/2 inch
 Temperature — 33°F minimum, 90° maximum

Heat of Rejection (BTU/Hr):

Average 10,400, Peak 14,400

Refrigerant R502:

	60 Cycle	50 Cycle
Air-Cooled	34 oz.	36 oz.
Water-Cooled	28 oz.	30 oz.
Remote	16 lb.	16 lb.

ELECTRICAL REQUIREMENTS

Requirement	208/230Volts, 50/60 Hertz, 1 Phase			220/240 Volts, 50 Hertz, 1 Phase		
	Air	Water	Remote	Air	Water	Remote
Maximum Fuse Size/Circuit Breaker	20 amp	20 amp	20 amp	15 amp	15 amp	15 amp
Minimum Circuit Ampacity	13.3 amp	13.3 amp	14.6 amp	13.5 amp	12.6 amp	14 amp

MANITOWOC ICE MACHINES ARE AIR CONDITIONING REFRIGERATION INSTITUTE (ARI) CERTIFIED AND RATED IN ACCORDANCE WITH AIR CONDITIONING REFRIGERATION INSTITUTE STANDARD 810-87

NOTE

Test conditions for standard ratings at 90°F air, 70°F water, and 30 ± 2 psig water inlet pressure.

Model Designation	Capacity (Lb. per 24 Hr.)	Potable Water Used (Gal. per 100 Lb. of Ice)	Condenser Water Used (Gal. per 100 Lb. of Ice)	Power Input (kW/Hr. 100 Lb. of Ice)
GR-0600A	428	26.7	--	8.4
GD-0602A	460	26.7	--	8.4
GY-0604A	460	26.7	--	8.3
GR-0601W	446	26.7	146	8.0
GD-0603W	480	26.7	146	7.4
GY-0605W	480	26.7	146	7.4
GR-0690N	446	26.7	--	9.2
GD-0692N	480	26.7	--	8.6
GY-0694N	480	26.7	--	8.6

WARRANTY INFORMATION

IMPORTANT

Read this section very carefully for warranty explanation. (Refer to Warranty Bond for complete details.)

OWNER WARRANTY REGISTRATION CARD

Warranty coverage begins the day the ice machine is installed.

IMPORTANT

To validate the installation date, the OWNER WARRANTY REGISTRATION CARD must be mailed in.

If the card was not returned, Manitowoc will use the date of sale to the Manitowoc Distributor as the first day of warranty coverage for your new ice machine.

About Your Warranty

The warranty statement is duplicated on the back cover of this guide.

For a detailed explanation of the warranty, we have compiled a list of the most commonly asked questions regarding warranty coverage.

Contact your local Manitowoc representative or our Wisconsin factory for further warranty information.

WARRANTY COVERAGE

(Effective for Ice Machines Installed after January 1, 1991)

Parts

1. The ice machine is warranted against defects in materials and workmanship under normal use and service for three (3) years from the date of the original installation. It is important to send in the warranty registration card so Manitowoc can begin your warranty on the installation date.
2. An additional two (2) years (five years total) warranty is provided on evaporator and compressor from the date of original installation.

Labor

1. Labor to repair or replace defective components is warranted for three (3) years from the date of original installation.
2. An additional two (2) years (**five (5) years total**) labor warranty is provided on the evaporator from the date of original installation.

Exclusions from Warranty Coverage

The following items are not included in the warranty coverage of the ice machine.

1. Normal maintenance, adjustments and cleaning as outlined in the Use and Care Guide.
2. Repairs due to unauthorized modifications to the ice machine or the use of nonapproved parts without written approval from Manitowoc Ice, Inc.
3. Damage from improper installation as outlined in the Installation Instructions, improper electrical supply, water supply or drainage; flood, storms, or other acts of God.
4. Premium labor rates due to holidays, overtime, etc. Travel time, flat rate service call charges, mileage and miscellaneous tools and material charges not listed on the payment schedule are excluded as well as additional labor charges resulting from inaccessibility of the ice machine.
5. Parts or assemblies subjected to misuse, abuse, neglect or accidents.
6. When the ice machine has been installed, cleaned and/or maintained inconsistent with the technical instructions provided in the Owner/Operator Use and Care Guide and the Installation Manual.

Authorized Warranty Service

To comply with the provisions of the warranty a refrigeration service company qualified and authorized by a Manitowoc distributor or a Contracted Service Representative must perform the warranty repair.

Please contact your local Manitowoc Distributor or Manitowoc Ice, Inc. for further information regarding warranty coverage. (NOTE: have model and serial numbers of ice machine available when calling. See Figure 1 for location of model and serial numbers.)

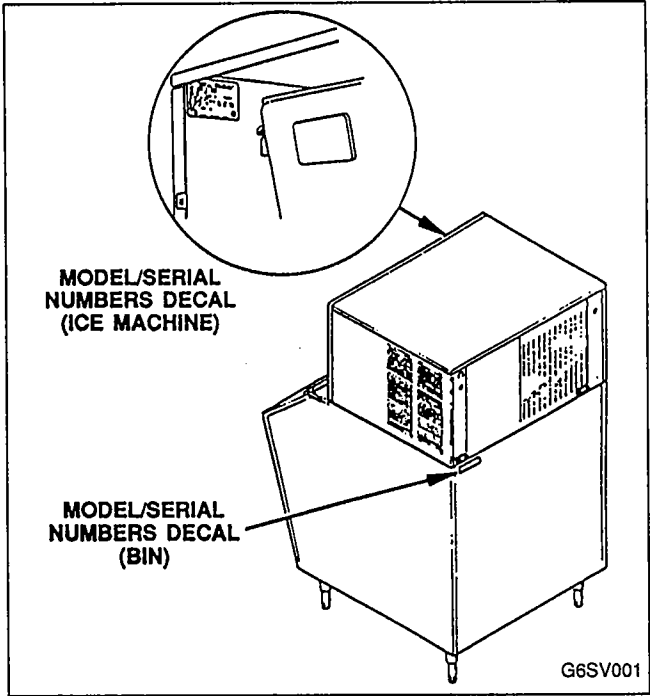
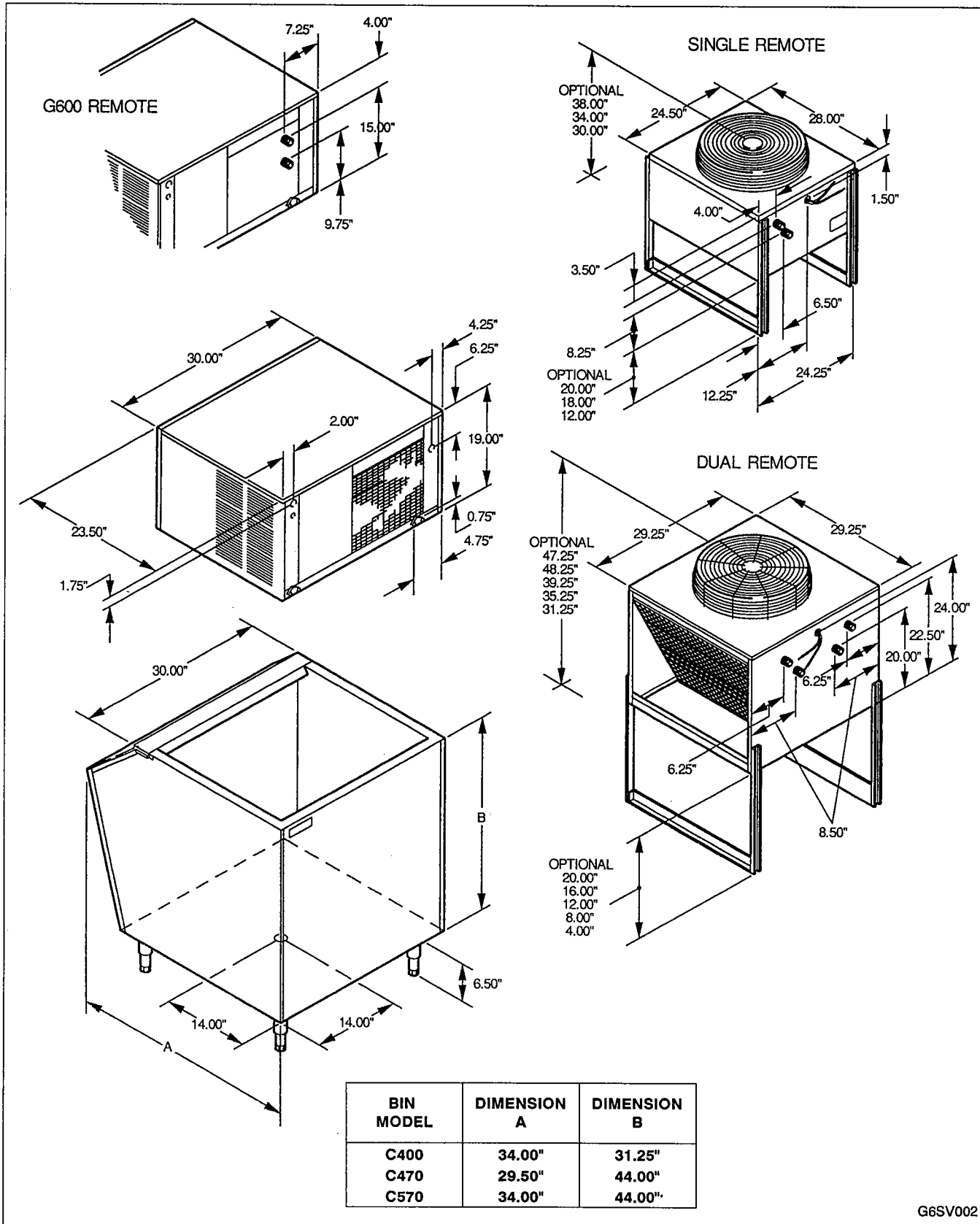

FIGURE 1. MODEL/SERIAL NUMBERS LOCATION

DIMENSIONS



G6SV002

FIGURE 2. DIMENSIONS

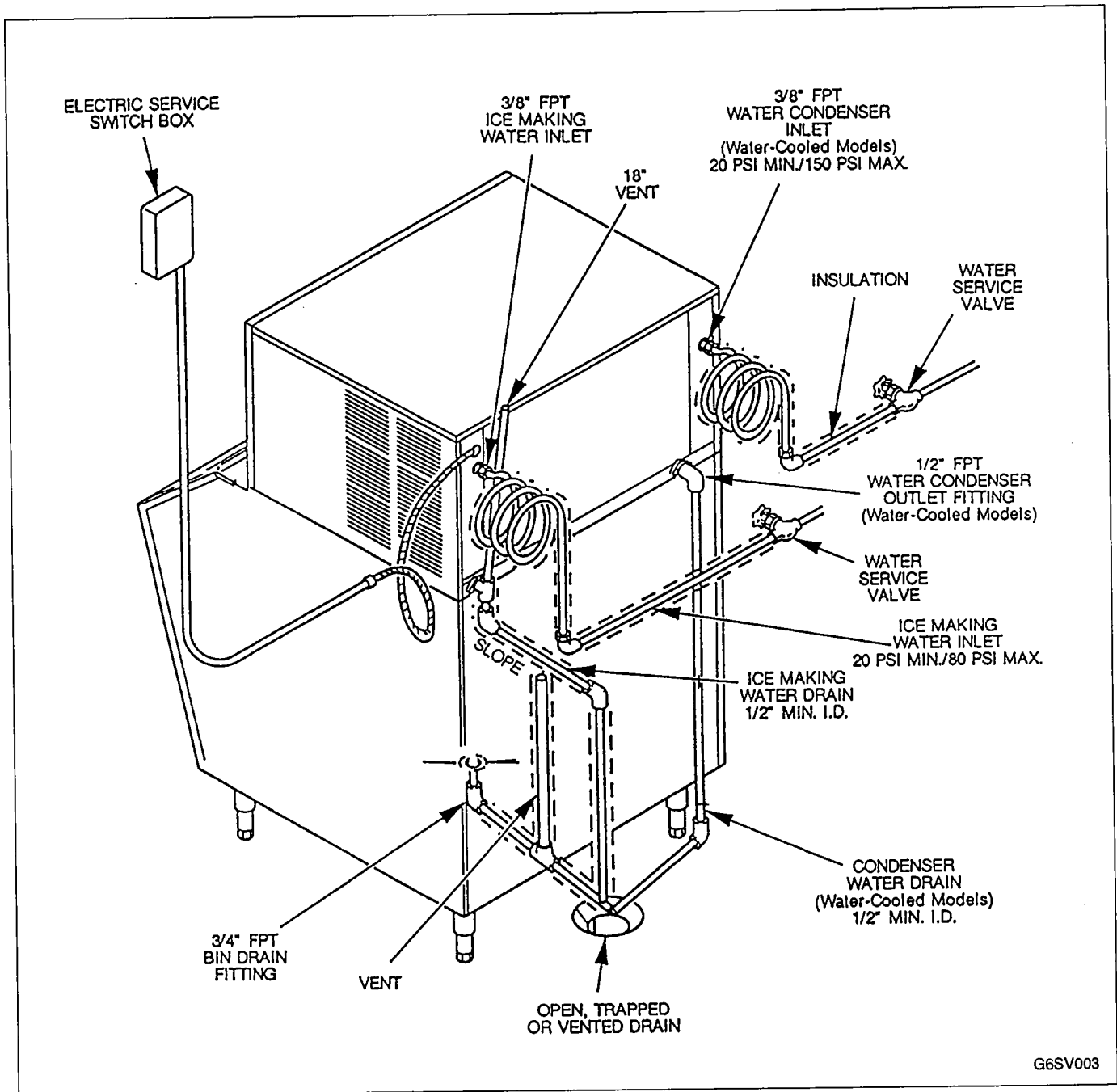

G6SV003

FIGURE 3. TYPICAL SELF-CONTAINED INSTALLATION

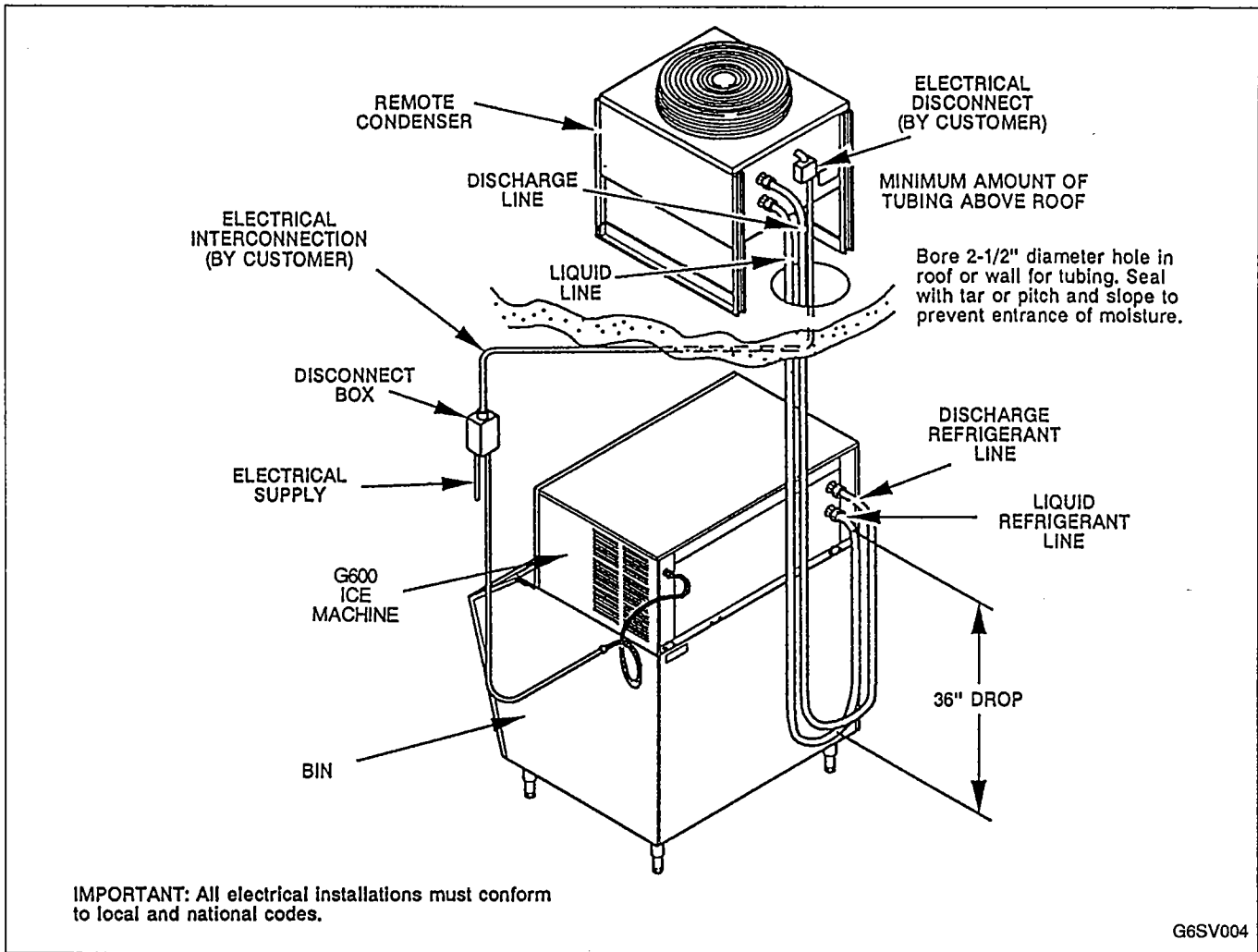

FIGURE 4. TYPICAL REMOTE SINGLE (AC) CONDENSER INSTALLATION

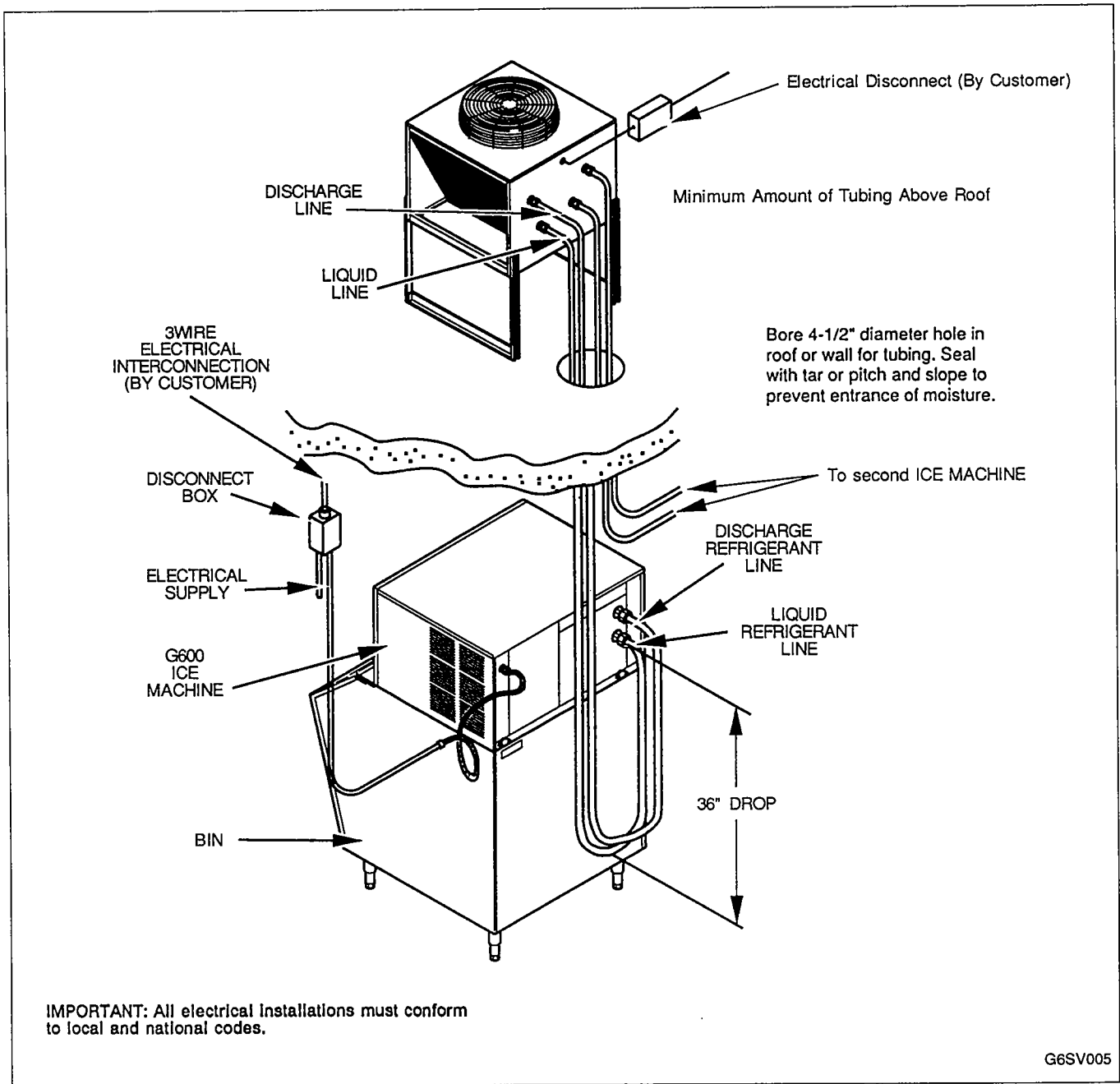

FIGURE 5. TYPICAL REMOTE DUAL (DC) CONDENSER INSTALLATION

COMPONENT IDENTIFICATION

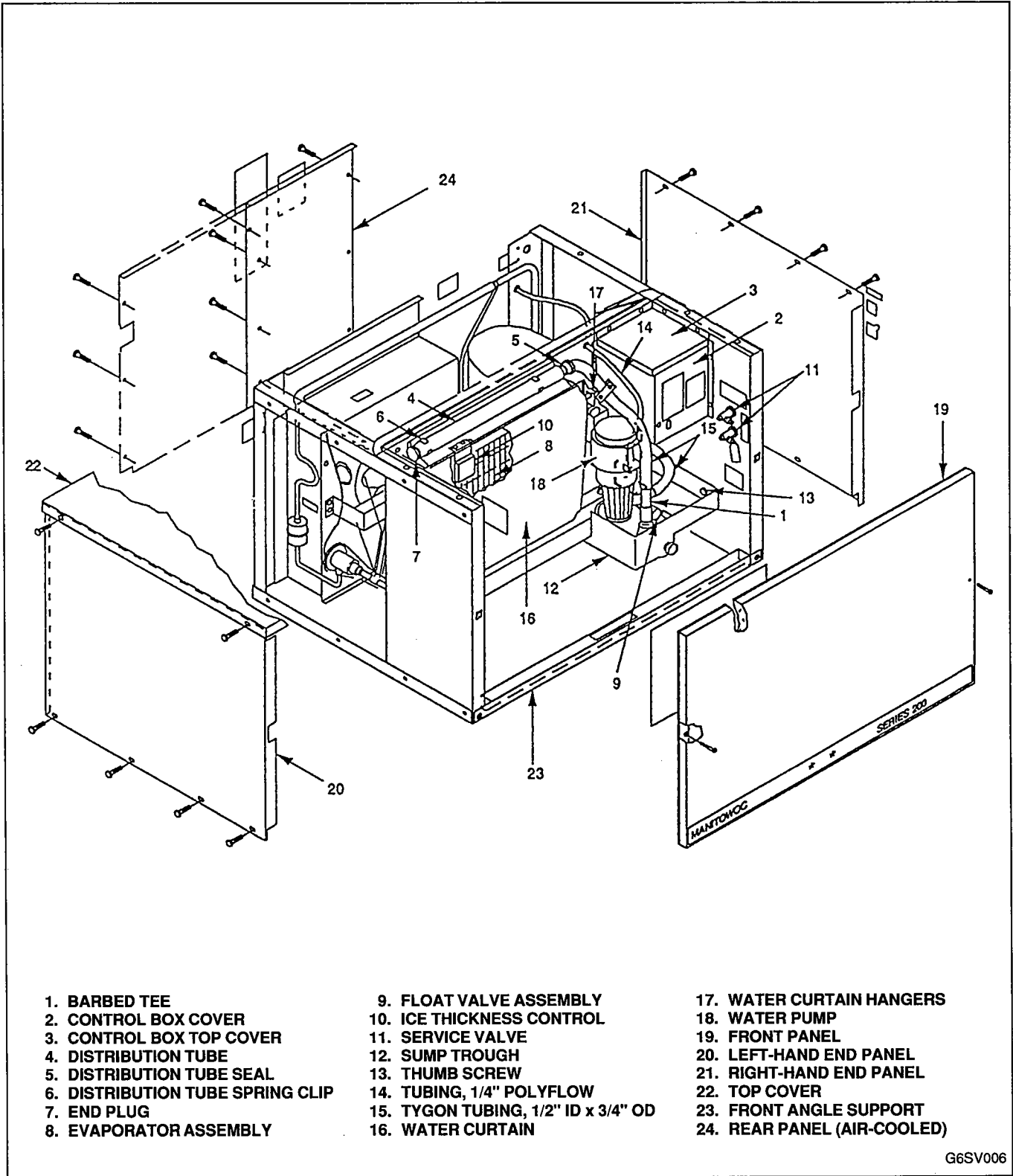
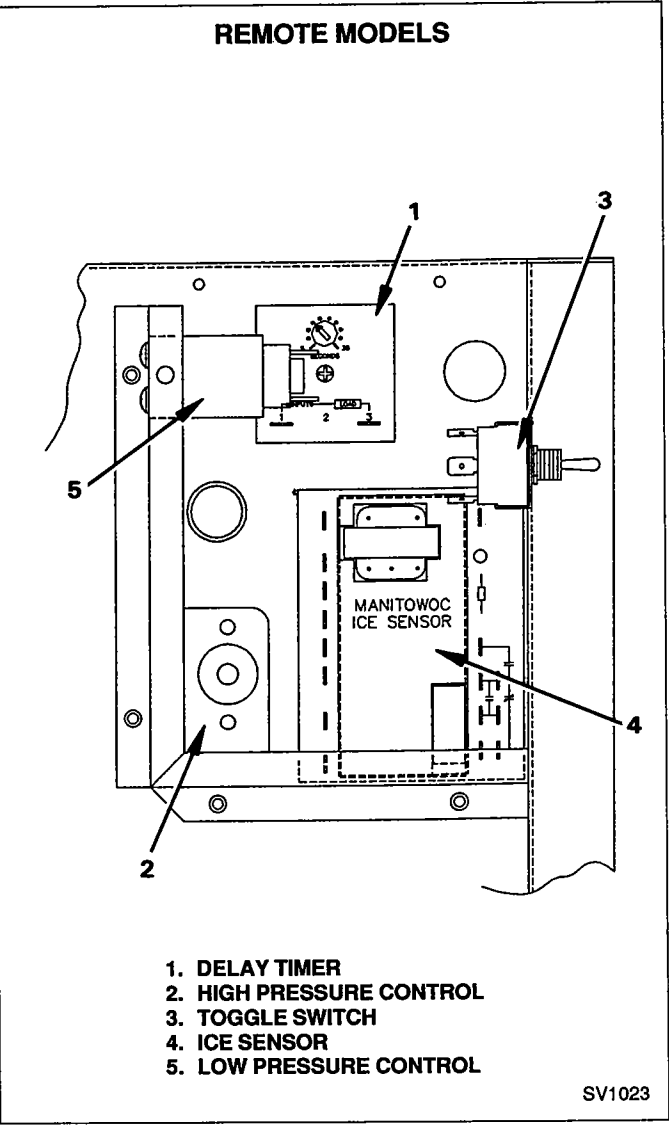
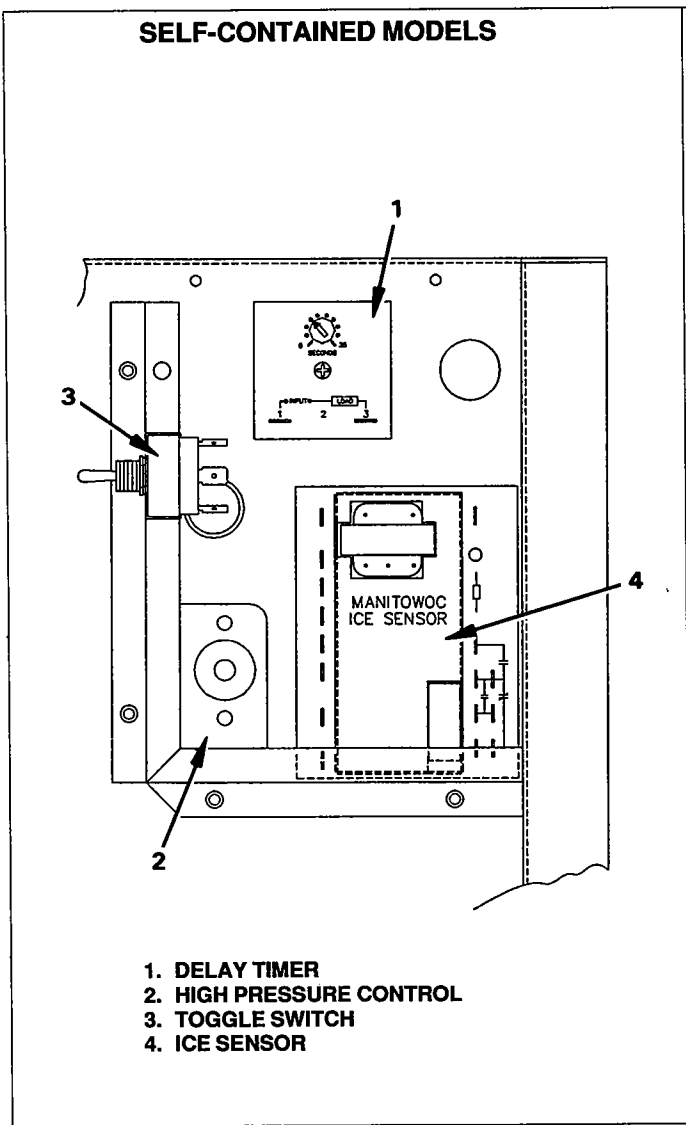

FIGURE 6. WATER DISTRIBUTION GROUP AND OUTER PANELS

G6SV006



SV1023

FIGURE 7. CONTROL BOX ASSEMBLY

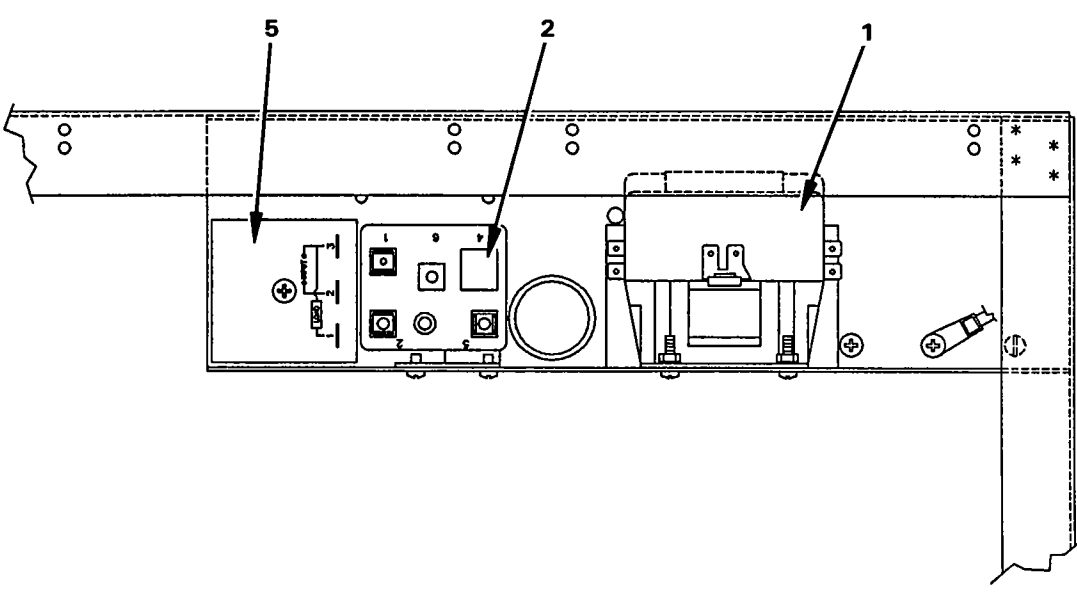
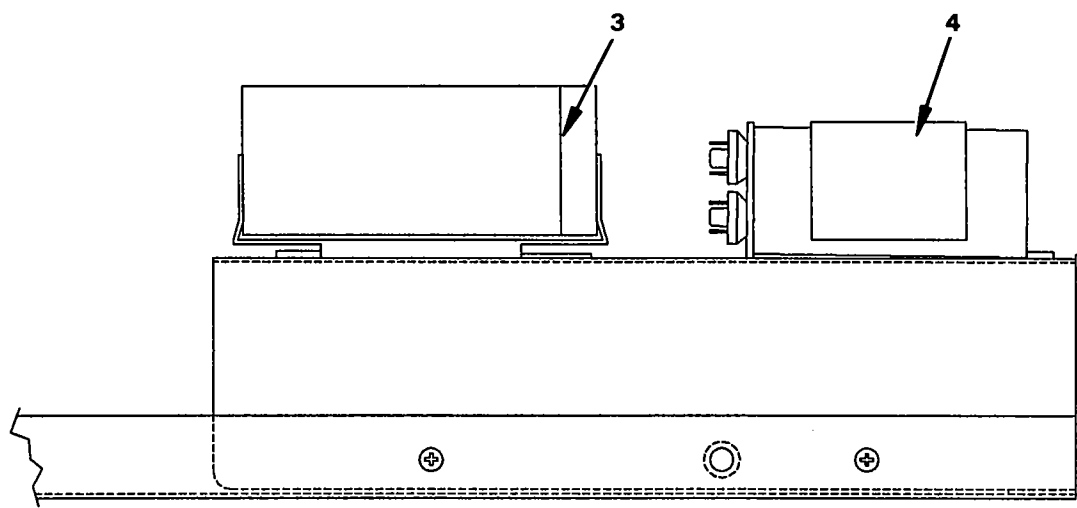

- 1. CONTACTOR
- 2. START RELAY
- 3. START CAPACITOR
- 4. RUN CAPACITOR
- 5. 7-SECOND DELAY TIMER
(SELF-CONTAINED MODELS)

SV1022

FIGURE 8. COMPRESSOR START COMPONENTS ELECTRICAL BOX

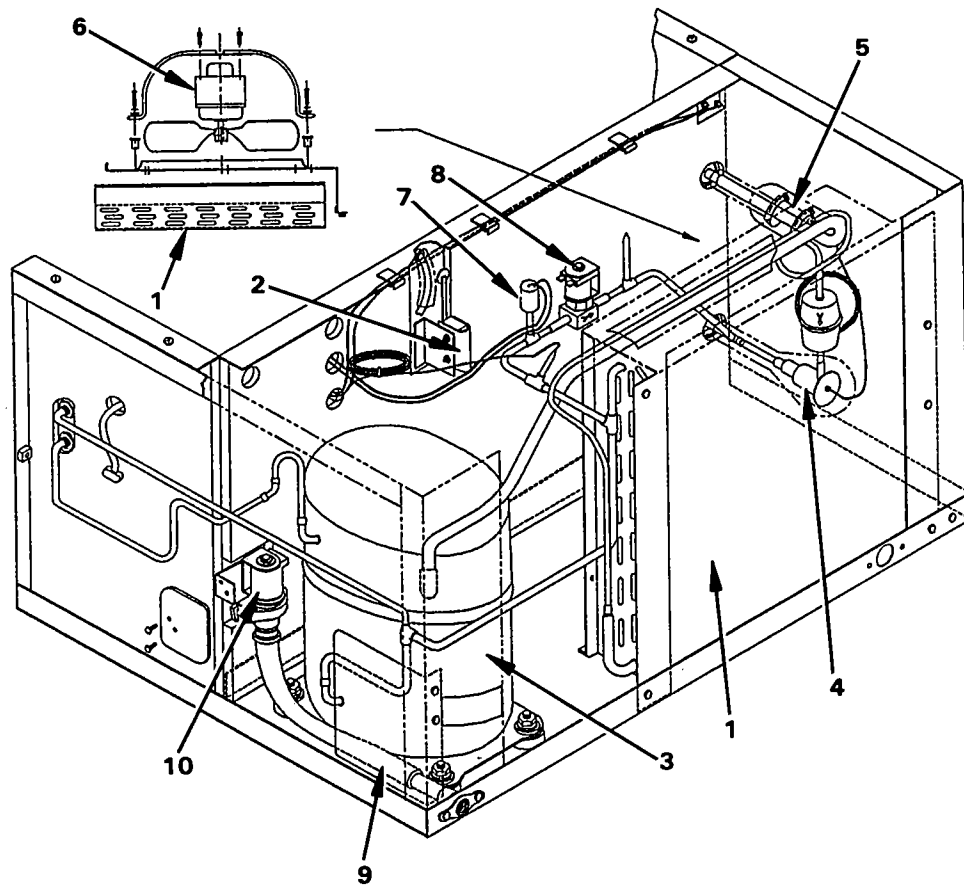

- | | |
|-------------------------|-------------------------|
| 1. AIR CONDENSER | 6. FAN |
| 2. BIN SWITCH | 7. FAN CYCLING CONTROL |
| 3. COMPRESSOR | 8. HOT GAS SOLENOID |
| 4. EXPANSION VALVE | 9. TUBING (DRAIN) |
| 5. EXPANSION VALVE BULB | 10. WATER DUMP SOLENOID |

SV1028

FIGURE 9. COMPRESSOR COMPARTMENT (AIR-COOLED)

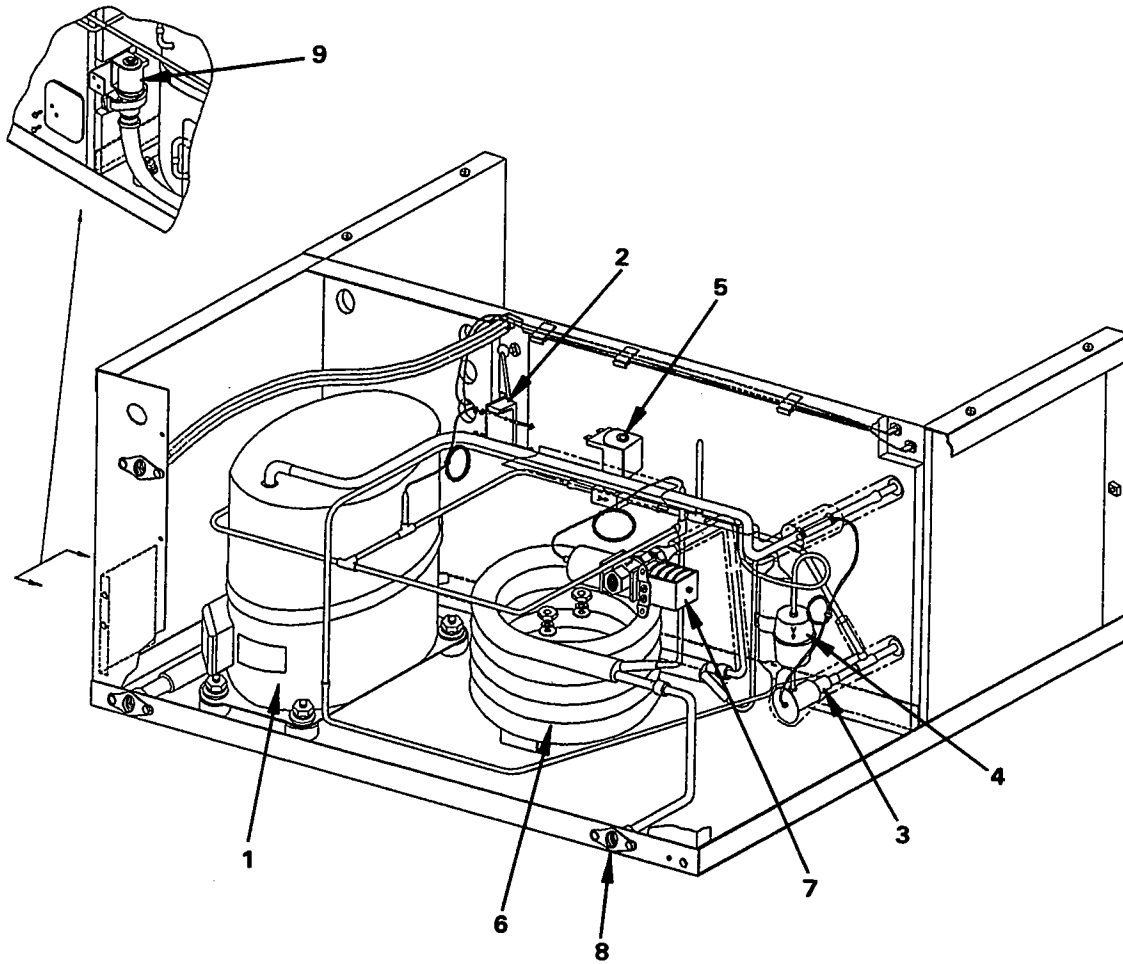

- | | |
|---------------------|---------------------------|
| 1. COMPRESSOR | 6. WATER-COOLED CONDENSER |
| 2. BIN SWITCH | 7. WATER REGULATING VALVE |
| 3. EXPANSION VALVE | 8. WATER ADAPTER |
| 4. DRIER | 9. DUMP VALVE |
| 5. HOT GAS SOLENOID | |

SV1027

FIGURE 10. COMPRESSOR COMPARTMENT (WATER-COOLED)

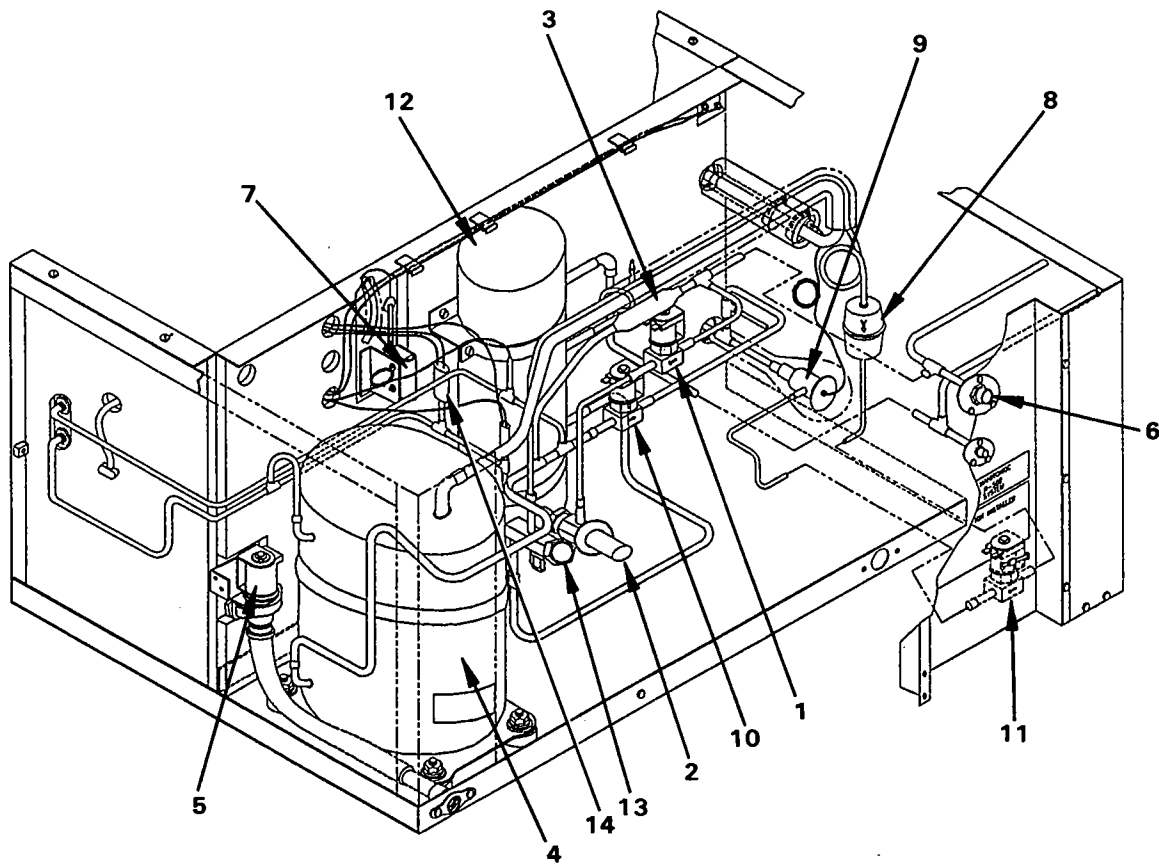

- | | |
|-----------------------------------------------|--------------------------------------|
| 1. HARVEST PRESSURE REGULATING SOLENOID | 8. DRIER |
| 2. HARVEST PRESSURE REGULATING VALVE (H.P.R.) | 9. EXPANSION VALVE |
| 3. CHECK VALVE | 10. HOT GAS SOLENOID VALVE |
| 4. COMPRESSOR | 11. LIQUID LINE SOLENOID |
| 5. DUMP VALVE | 12. RECEIVER |
| 6. COUPLING, MALE | 13. SERVICE VALVE |
| 7. BIN SWITCH | 14. SUCTION PRESSURE LIMITER CONTROL |

SV1029

FIGURE 11. COMPRESSOR COMPARTMENT (REMOTE CONDENSER)

INTERIOR CLEANING

For efficient operation, clean and sanitize ice machine every six months.

IMPORTANT

Do not use hot water. If ice machine requires cleaning and sanitizing more frequently, consult a qualified service company to test the water quality and recommend appropriate water treatment.

Before cleaning, check water dump valve for proper operation (see Cleaning Water Dump Valve, page 19). Deposits may accumulate in the valve causing leakage or restriction of water flow.

REMOVAL OF PARTS FOR CLEANING

1. Loosen two screws holding front panel in place and remove front panel.
2. Set ICE/OFF/WATER PUMP switch at OFF after ice falls from evaporator at completion of harvest cycle, or set switch at OFF and allow ice to melt off evaporator.



CAUTION

Never use any type of object to force ice from evaporator as damage may result.

3. Turn off water to the ice machine at water service valve(s).
4. Stacked ice machines:
 - a. Remove top panel.
 - b. Lift ice chute up and out of ice machine.
5. Remove all ice from bin.
6. Remove water curtain.
7. Remove drain plug from water trough and allow water to drain into bin.

REMOVE WATER PUMP (Figure 12)

1. Disconnect water pump power cord.

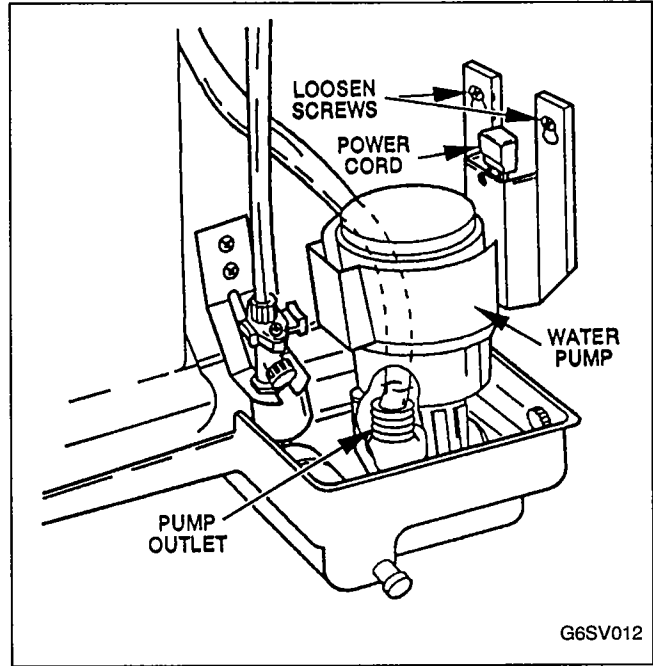

FIGURE 12. WATER PUMP REMOVAL

2. Disconnect hose from pump outlet.
3. Loosen two screws holding pump mounting bracket to rear bulkhead.
4. Lift pump and bracket assembly off screws.

REMOVE FLOAT VALVE (Figure 13)

1. Turn valve splash shield clockwise a full turn or two, then pull the valve forward off the mounting bracket.
2. Disconnect the water inlet tube from the float valve at the compression fitting.
3. Remove filter screen and cap.

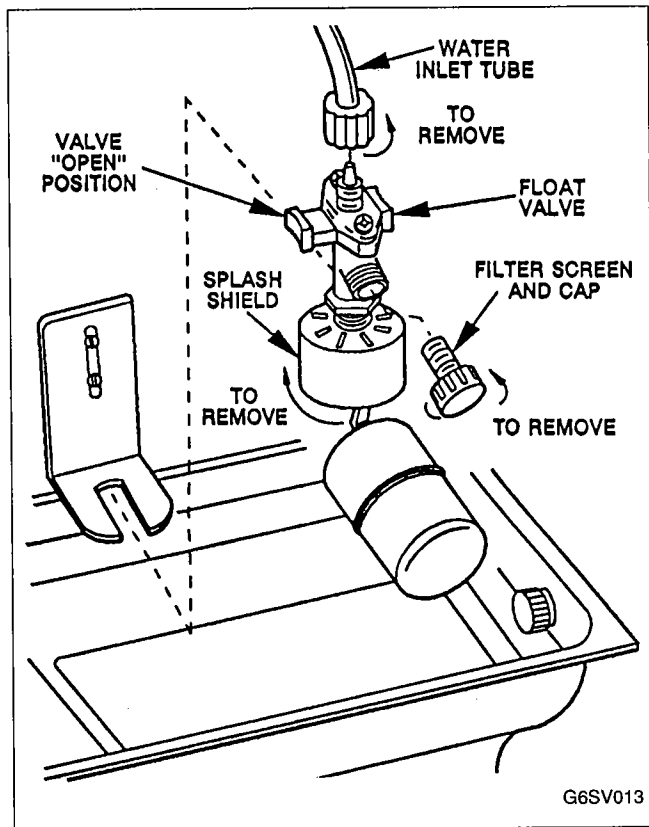

FIGURE 13. FLOAT VALVE REMOVAL

REMOVE DISTRIBUTION TUBE (Figure 14)

1. Remove distribution tube from the two spring clips holding it in place.
2. Disconnect the hose from the distribution tube and from the "T."

NOTE
To reinstall distribution tube, align locating pin on top extrusion with hole in distribution tube.

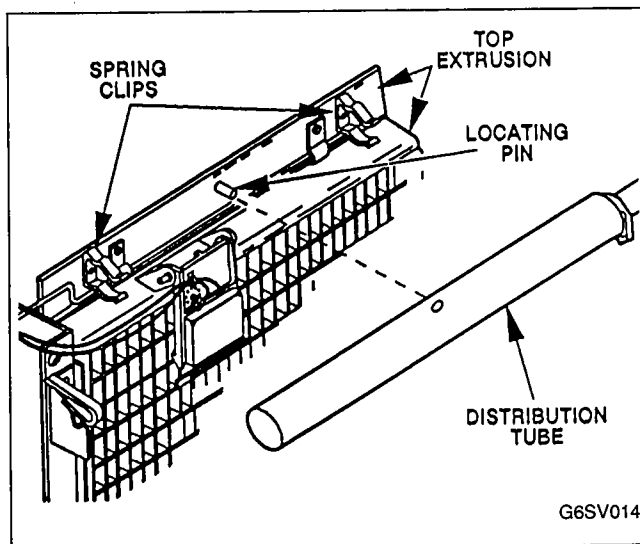

FIGURE 14. DISTRIBUTION TUBE REMOVAL

DISASSEMBLE DISTRIBUTION TUBE (Figure 15)

NOTE
Disassembly of the distribution tube is not usually necessary as normal cleaning of the ice machine will clean the tube. The distribution tube should only be disassembled if, after normal cleaning procedures, there is inadequate water flow from the distribution tube.

1. Heat rubber end plugs on distribution tube in warm water to soften them.
2. Remove end plugs and inner distribution tube.
3. Reheat rubber plugs in warm water after cleaning is complete and reassemble distribution tube.

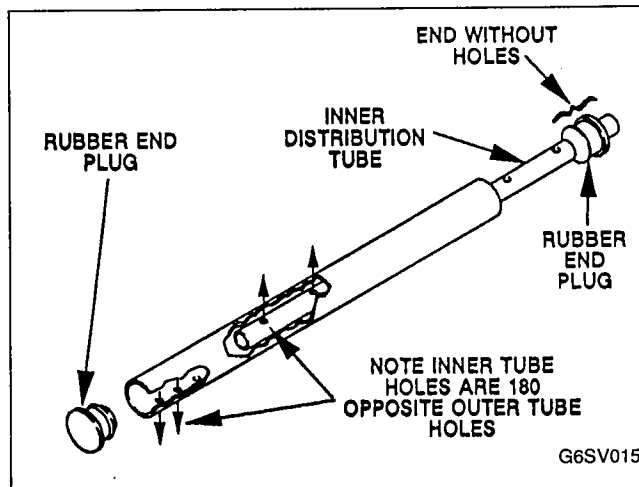

FIGURE 15. DISTRIBUTION TUBE DISASSEMBLY

NOTE

Position the holes in the inner and outer tubes 180° opposite each other when reassembling. The end of the inner distribution tube without holes must extend from the outer tube when reassembled to allow for attachment of the water line from the pump.

REMOVE ICE THICKNESS PROBE (Figure 16)

1. Disconnect wire leads.
2. Compress side of probe at top near hinge pin and disengage it from the bracket.

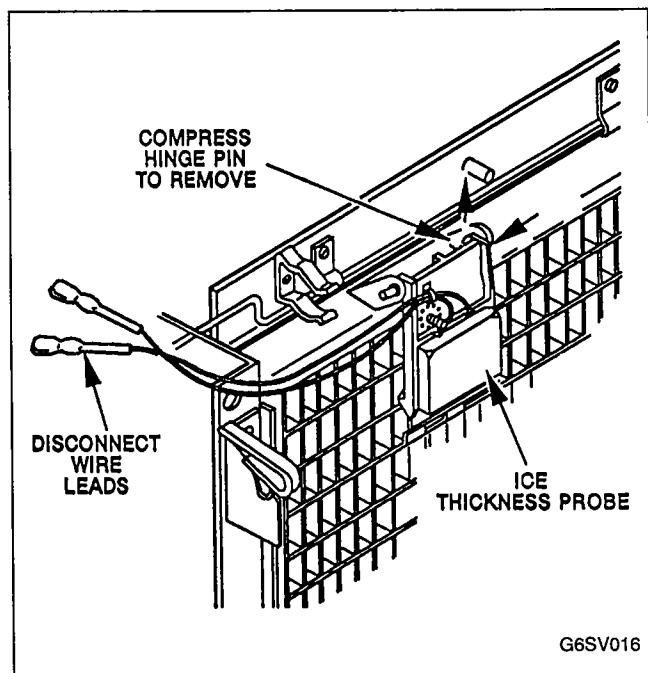

FIGURE 16. ICE THICKNESS PROBE REMOVAL

REMOVE WATER TROUGH (Figure 17)

1. Remove thumb screws. Support trough while removing thumb screws.
2. Lower right side of trough into bin while disengaging left side of trough from holding pegs and remove trough from ice machine.

NOTE

Stacked ice machines: Remove trough from top ice machine by lifting up on front right side of trough, then pull out to disengage trough from pegs on left side of cabinet.

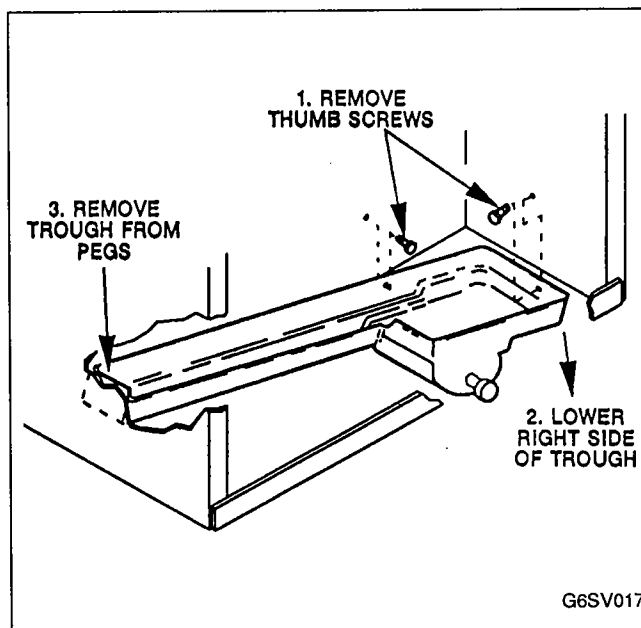

FIGURE 17. WATER TROUGH REMOVAL

CLEANING PROCEDURES

Ice Machine Cleaner is for removal of lime scale or other mineral deposits. It is not used for removal of algae or slime. Refer to Sanitizing for removal of algae and slime.



CAUTION

Use only Manitowoc Ice Machine Cleaner, Part No. 94-0546-3, in recommended concentration as this is compatible with materials used in the manufacture of Manitowoc Ice Machines.

1. Soak parts in a solution of no more than 16 ounces of cleaner to one gallon of warm water. Use a brush (**DO NOT USE A WIRE BRUSH**) or a sponge to clean the parts, taking care not to damage them.



CAUTION

Do not immerse the water pump motor in the cleaning solution. Also, use care when cleaning the ice thickness probe so as not to move the adjusting screw.

2. Use the cleaning solution and a brush or sponge to remove scale build-up from the top, sides and bottom extrusions, the inside of the ice machine panels, and the entire inside of the ice bin.

A dirty top extrusion, Figure 14, could result in uneven water flow over the evaporator. Ensure all scale and dirt are removed.

3. Thoroughly rinse with clean water all parts and surfaces washed with the cleaning solution.

NOTE

Incomplete rinsing of the ice thickness probe could leave residue which could cause the ice machine to go into premature harvest. For best results, brush or wipe off while rinsing and then wipe dry.

4. Reinstall all parts removed for cleaning except front panel and top chute (if stacked).

CLEANING THE EVAPORATOR

NOTE

Failure to clean other parts prior to cleaning evaporator may result in poor cleaning of the evaporator surface.

1. Turn on water to ice machine at water service valve and verify float valve is open, Figure 13, page 15.
2. Allow trough to fill to proper operating level, Figure 13, page 15.

3. Set ICE/OFF/WATER PUMP switch at WATER PUMP.
4. Add two ounces of cleaner to water trough and allow solution to circulate a maximum of 10 minutes.

NOTE

Use a soft brush on excessively dirty evaporator to help remove deposits. Ensure connecting holes in back corners of cube molds are open.

5. Set ICE/OFF/WATER PUMP switch at OFF.
6. Shut off water at float valve. See Figure 13.
7. Drain water trough by removing drain plug.
8. Thoroughly rinse trough with clean water, then reinstall drain plug.
9. Turn on water at float valve.
10. Set ICE/OFF/WATER PUMP switch at WATER PUMP and allow water trough to fill to proper operating level.
11. Sanitize ice machine after cleaning.
12. Perform Operational Checks. Refer to Owner/Operator Use and Care Guide.

SANITIZING

Sanitizer is used for removal of algae or slime AND AFTER USE OF MANITOWOC ICE MACHINE CLEANER. It is not used for removal of lime scale or other mineral deposits.

1. Loosen two screws holding front panel in place and remove front panel.
2. Set ICE/OFF/WATER PUMP switch at OFF after ice falls from evaporator at completion of harvest cycle or set switch at OFF and allow ice to melt off evaporator.



CAUTION

Never use any type of object to force ice from evaporator as damage may result.

3. Stacked ice machines: Remove ice chute as described under Removal of Parts for Cleaning, page 14.
4. Remove water curtain, Figure 44.
5. Remove all ice from bin.
6. Set ICE/OFF/WATER PUMP switch at WATER PUMP.
7. Add one ounce of sanitizer to water trough and allow solution to circulate a minimum of one minute.
8. Drain solution from trough by removing drain plug, Figure 41.
9. Thoroughly rinse trough with clean water, then reinstall drain plug.
10. Wash all surfaces requiring sanitizing (ice machine and bin) with a solution of one ounce of sanitizer to up to four gallons of water.
11. Thoroughly rinse all sanitized surfaces with clean water.
12. Set ICE/OFF/WATER PUMP switch at ICE.
13. Perform Operational Checks. Refer to Owner/Operator Use and Care Guide. Discard first batch of ice.

CHECKING AND CLEANING THE WATER DUMP VALVE

OPERATION CHECK

1. Remove top and right side panel.
2. Set ICE/OFF/WATER PUMP switch at ICE.
3. Check clear plastic outlet drain hose of dump valve, Figure 18, for leakage while the ice machine is in the freeze cycle.
4. If the dump valve is leaking or restricted, remove, disassemble and clean.

REMOVE WATER DUMP VALVE (Figure 18)



WARNING

Disconnect electric power to the ice machine at the electric service switch box.

NOTE

Water dump valve can be cleaned without removing.

1. Drain water trough by removing drain plug.
2. Remove water dump valve shield from water dump valve mounting bracket.

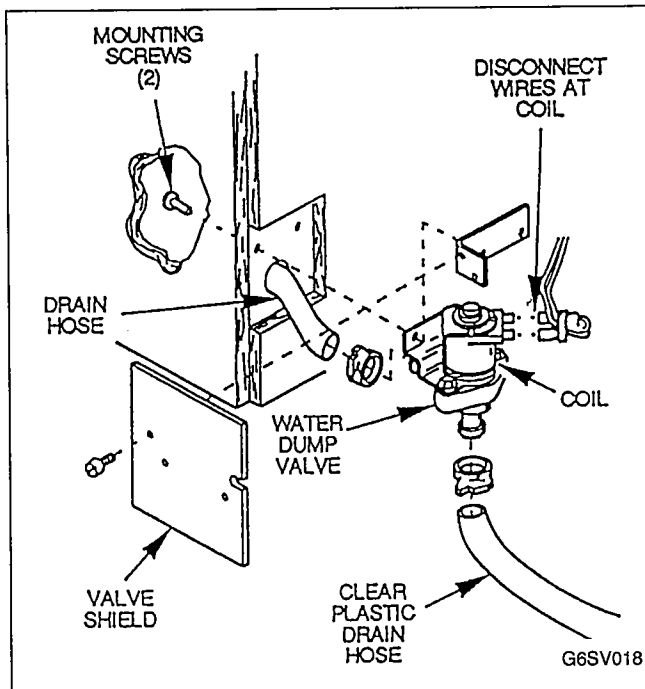

FIGURE 18. WATER DUMP VALVE REMOVAL

3. Disconnect wires from dump valve coil.
4. Remove two screws securing dump valve and mounting bracket.
5. Remove tubing from dump valve by twisting off hose clamps.

DISASSEMBLE PLASTIC BODY WATER DUMP VALVE (Figure 19)

1. Lift cap and slide coil retainer cap from top of coil.
2. Lift coil assembly off valve body. Note position of coil assembly on valve before removing. When reassembling valve, ensure coil is in same position.
3. Press down on enclosing tube plastic nut and rotate nut 1/4 turn and remove nut and enclosing tube from dump valve.
4. Remove enclosing tube, plunger and plastic gasket from valve body.

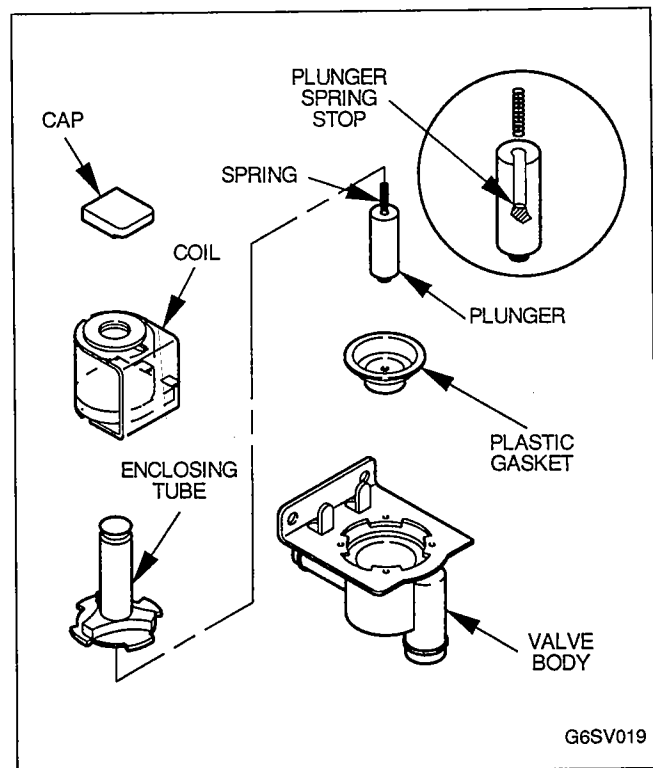

FIGURE 19. PLASTIC BODY WATER DUMP VALVE DISASSEMBLY

DISASSEMBLE BRASS BODY WATER DUMP VALVE (Figure 20)

1. Pry off retainer on top of dump valve coil with flat tip screwdriver.

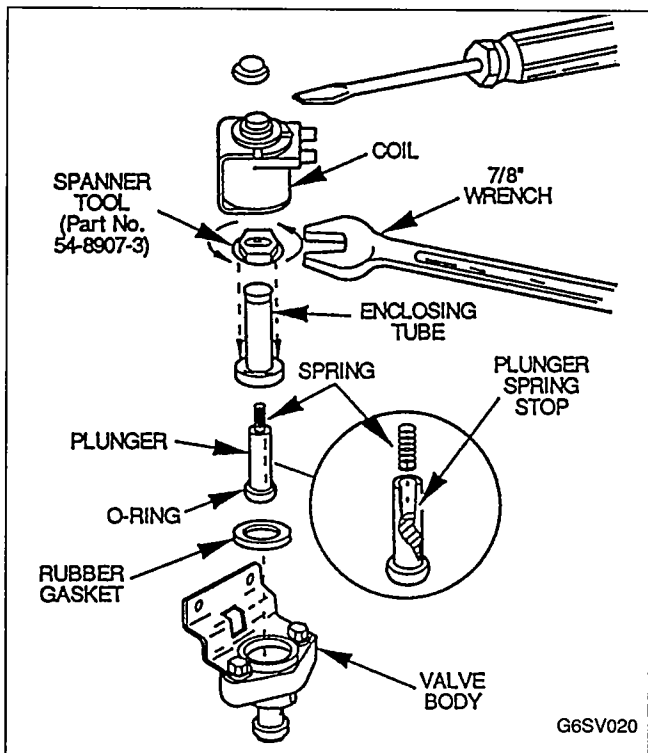

FIGURE 20. BRASS BODY WATER DUMP VALVE DISASSEMBLY

2. Lift coil assembly off valve body. Note position of coil assembly on valve before removing. When reassembling valve, ensure coil is in same position.

3. Place spanner tool (Manitowoc Part No. 54-8907-3, available through your local Manitowoc Distributor) over enclosing tube and insert pins on spanner tool into holes on bottom of tube.
4. Turn spanner tool counterclockwise with 7/8" wrench and remove enclosing tube, plunger and rubber gasket from valve body.

CLEANING WATER DUMP VALVE

NOTE

It is not necessary to remove spring from plunger when cleaning. If spring is removed, insert *flared* end of spring into slotted opening in top of plunger until spring comes in contact with plunger spring stop. Use care not to stretch or damage spring in plunger when cleaning..

1. Soak components in cleaning solution (refer to Cleaning Procedures, page 16). Remove heavy scale deposits with a stiff-bristle brush. Use a small bottle brush to clean inside the enclosure tube. Wipe off rubber gasket with soft cloth.



CAUTION

Do not soak coil assembly.

2. Thoroughly rinse components with clean water.
3. Reassemble water dump valve and reinstall in ice machine.

SEQUENCE OF OPERATION

FREEZE CYCLE (Self-Contained Air or Water Cooled) (Prechill of Evaporator)

At the beginning of the freeze cycle the water pump will not start for 20 seconds. This allows the evaporator to prechill, minimizing build-up of slush in the sump trough.

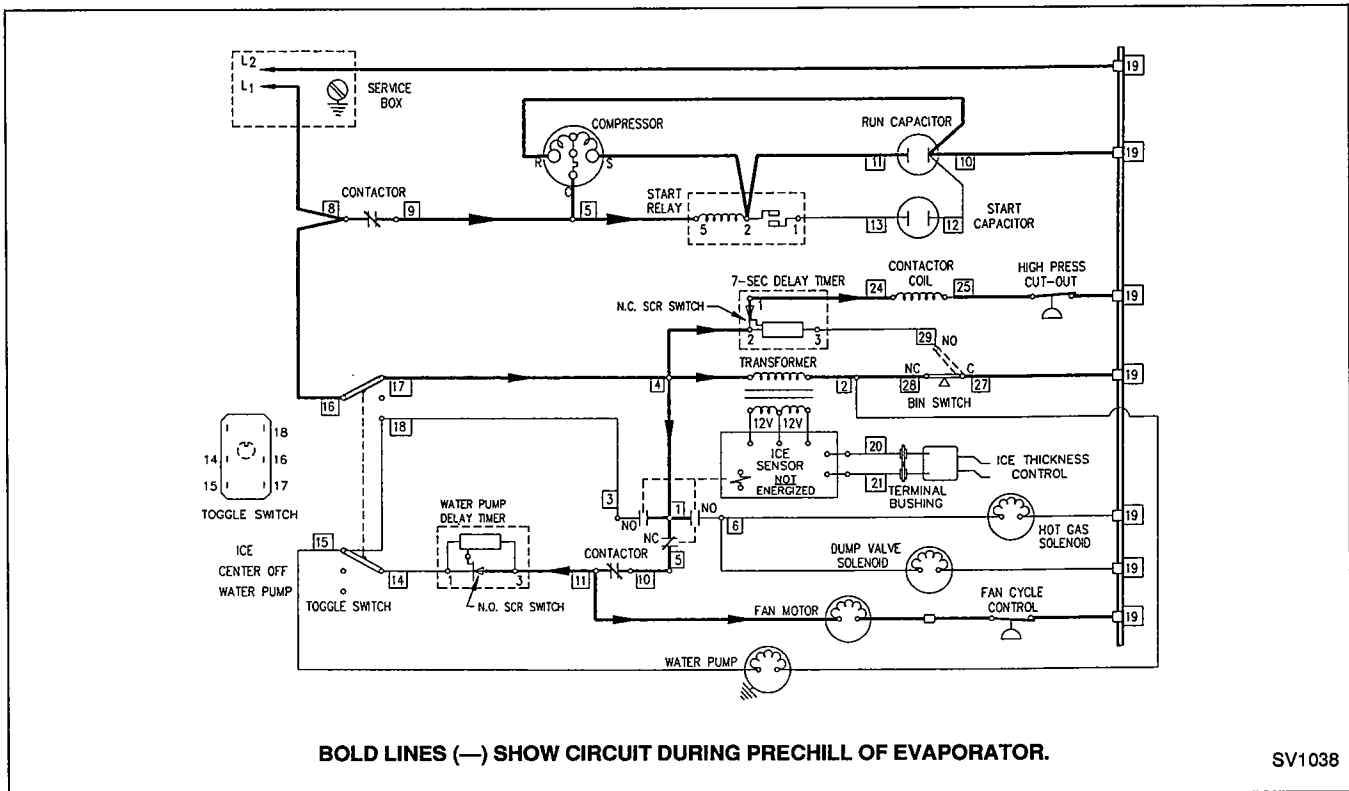

FIGURE 21. PRECHILL ELECTRICAL SEQUENCE

Prechill Electrical Sequence

1.	Bin switch	closed
2.	High Pressure Cut-Out Control	closed
3.	Toggle switch	ice position
4.	Compressor	on
5.	Primary power to transformer	yes
6.	Ice Sensor Relay	not energized
A)	Ice Sensor Relay contact #6	open
1.	Hot gas solenoid	off
2.	Dump valve solenoid	off
B)	Ice Sensor Relay contact #3 (water pump circuit during harvest cycle)	open
C)	Ice Sensor Relay contact #5	closed
1.	Fan motor (air-cooled models)	on
	Fan cycle control	may cycle the fan on/off to maintain discharge pressure
2.	Water pump delay timer (the timer starts a preset 20-second delay period)	S.C.R. switch open
D)	Water pump (through Ice Sensor Relay contact #5 and water pump delay timer)	off
7.	7-Second Delay Timer	not energized
A)	S.C.R. switch	closed
B)	Contactor	energized

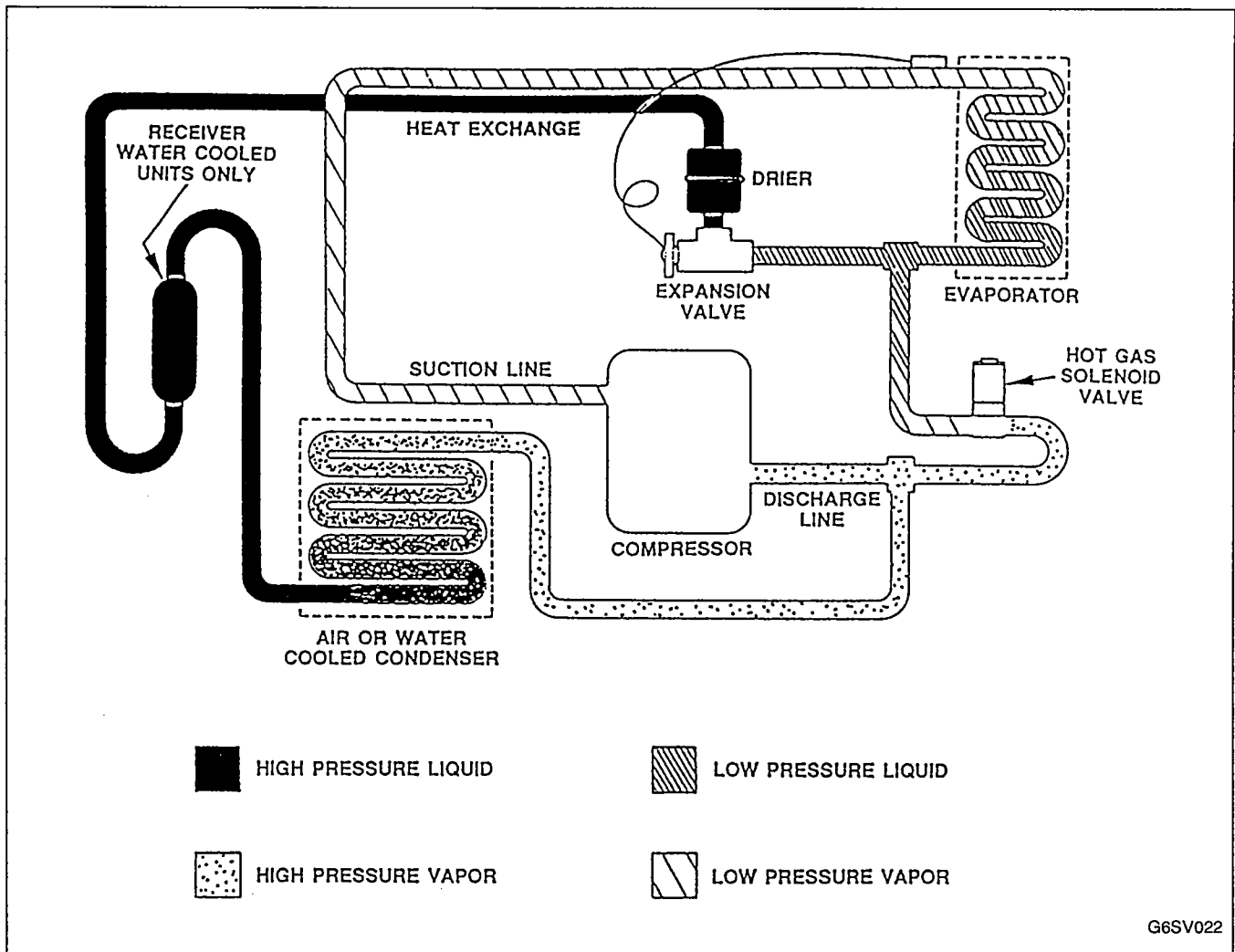

FIGURE 22. PRECHILL REFRIGERATION SEQUENCE

Prechill Refrigeration Sequence

There is no water flow over the evaporator during the prechill. The refrigerant absorbs heat (picked up during the harvest cycle) from the evaporator plate. The suction pressure decreases during prechill.

Prechill Water Flow Sequence

Water does not flow during the prechill.

FREEZE CYCLE (Self-Contained Air or Water Cooled)

The freeze cycle begins when the Water Pump Delay Timer completes the 20-second delay and starts the water pump.

Water flows over the evaporator, forming ice. The freeze cycle will last approximately 10-20 minutes, depending on air and water conditions. (Refer to Cycle Time Chart, page 55.)

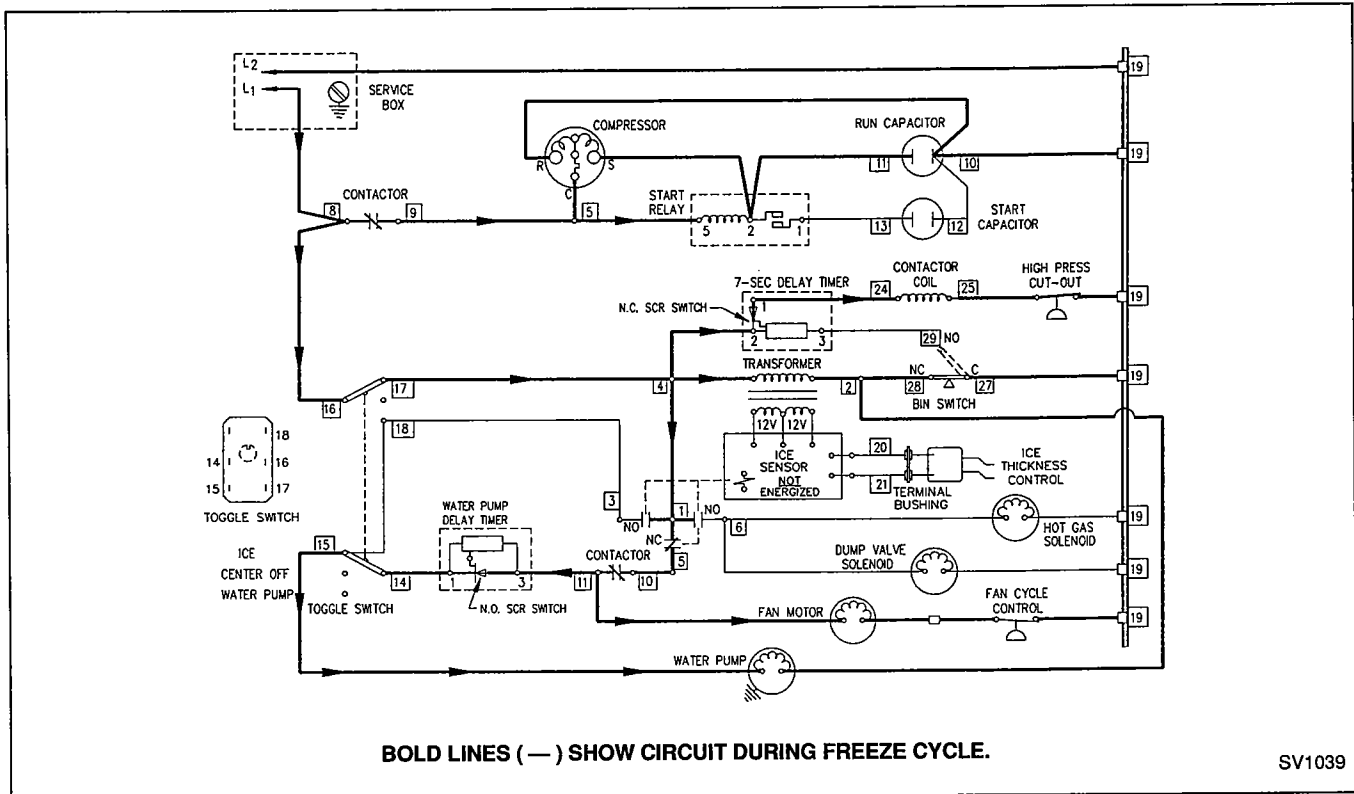

FIGURE 23. FREEZE CYCLE ELECTRICAL SEQUENCE

Freeze Cycle Electrical Sequence

1.	Bin switch	closed
2.	High Pressure Cut-Out Control	closed
3.	Toggle switch	ice position
4.	Compressor	on
5.	Primary power to transformer	yes
6.	Ice Sensor Relay	not energized
A)	Ice Sensor Relay contact #6	open
1.	Hot gas solenoid	off
2.	Dump valve solenoid	off
B)	Ice Sensor Relay contact #3 (water pump circuit during harvest cycle)	open
C)	Ice Sensor Relay contact #5	closed
1.	Fan motor (air-cooled models)	on
	Fan cycle control	may cycle the fan on/off to maintain discharge pressure
2.	Water pump delay timer	S.C.R. switch closed
D)	Water Pump (through Ice Sensor Relay contact #5 and water pump delay timer)	on
7.	7-Second Delay Timer	not energized
A)	S.C.R. switch	closed
B)	Contactor	energized

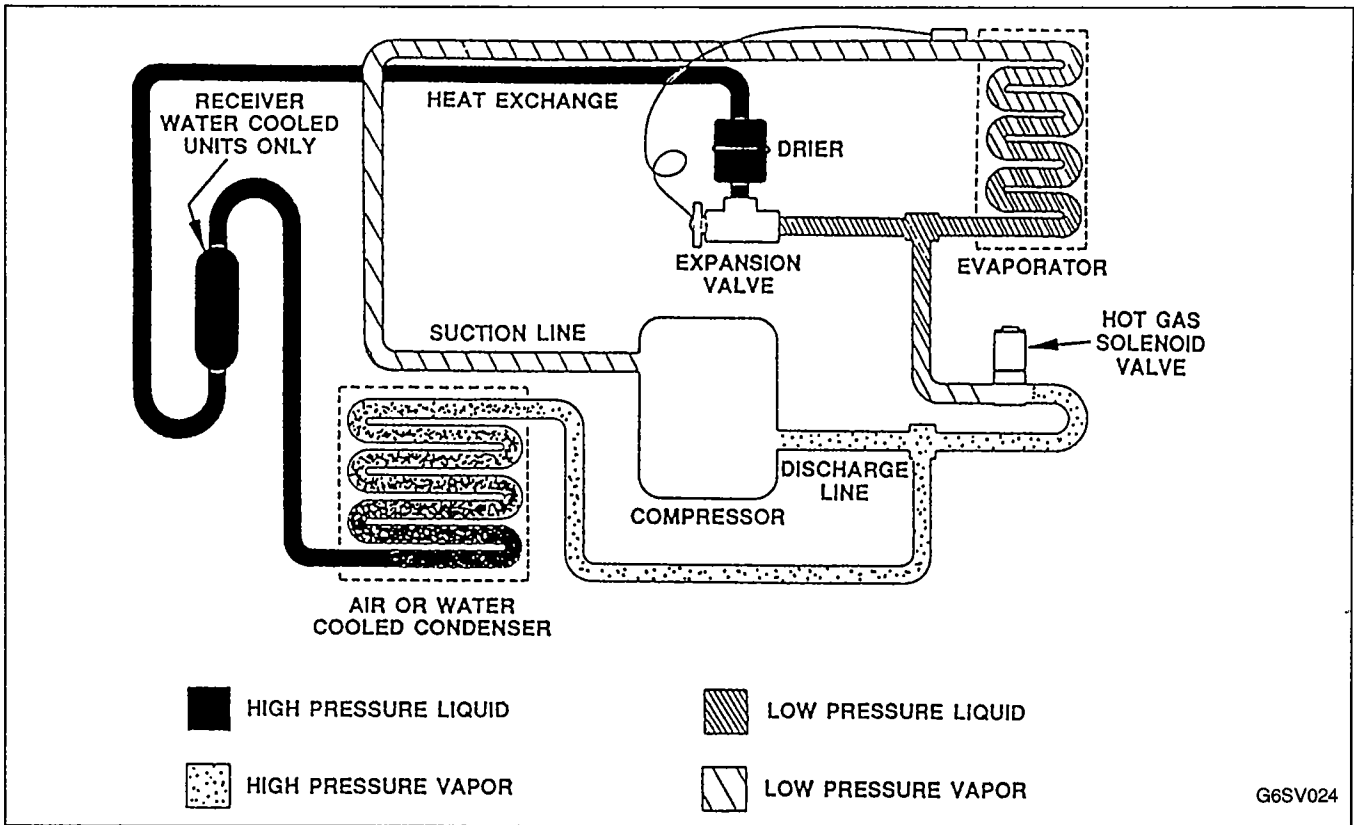

FIGURE 24. FREEZE CYCLE REFRIGERATION SEQUENCE

Freeze Cycle Refrigeration Sequence

The refrigerant is absorbing heat from water running over the evaporator surface. The suction pressure gradually drops as ice forms.

Freeze Cycle Water Flow Sequence

Water from the sump trough is pumped to the distribution tube above the evaporator. It flows evenly over the evaporator to form ice. The float valve maintains proper water level in the sump trough.

FREEZE CYCLE PRESSURES

Ambient Temp. °F	Head Pressure PSI	Suction Pressure PSI
Air Cooled		
50	175-220	36-20
70	180-225	40-22
80	200-250	42-24
90	240-280	44-26
100	260-300	46-26
Water Cooled		
50	215-225	38-24
70	215-225	40-26
80	215-225	42-26
90	215-225	44-26
100	215-225	44-26

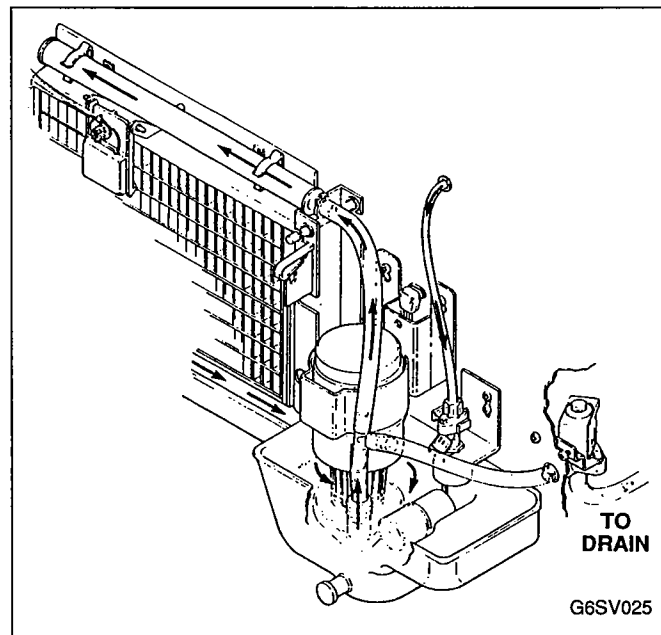

FIGURE 25. FREEZE CYCLE WATER FLOW SEQUENCE

HARVEST CYCLE (Self-Contained Air or Water Cooled)

The harvest cycle begins when water flowing over the ice on the evaporator contacts the probes on the ice thickness control. After a constant 6-10 seconds of water contact, the relay on the ice sensor board is energized, changing contacts #3, #5 and #6.

Water stops flowing over the evaporator and is pumped through the dump valve. As hot gas warms the

evaporator, the ice cubes slide, as a unit, off the evaporator into the storage bin. The harvest cycle will last approximately 1-1/2 to 2 minutes. **Back to freeze cycle prechill:** the falling ice swings the bottom of the water curtain out, momentarily activating (opening) the bin switch. This interrupts the primary power supply at the transformer, de-energizing the ice sensor relay on the unitized sensor board.

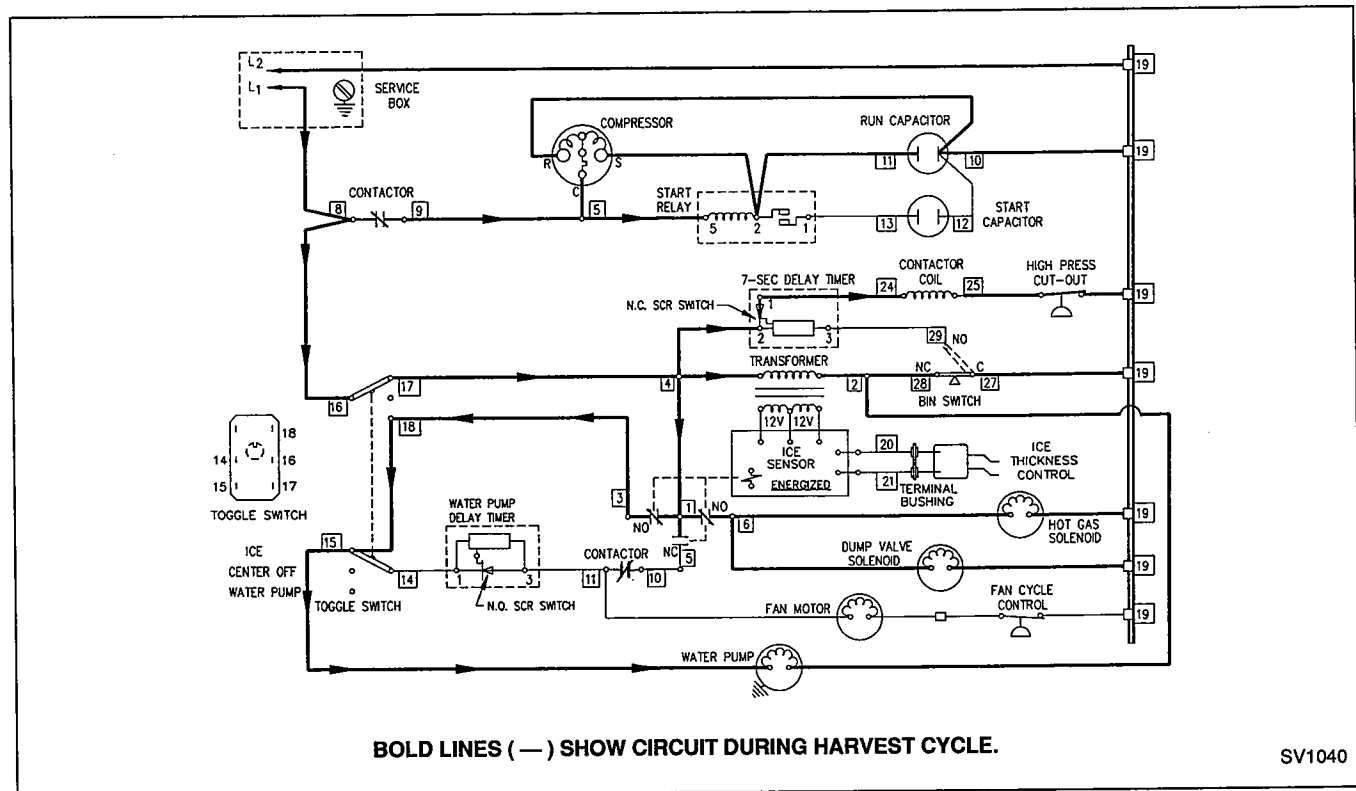

FIGURE 26. HARVEST CYCLE ELECTRICAL SEQUENCE

Harvest Cycle Electrical Sequence

1.	Bin switch	closed
2.	High Pressure Cut-Out Control	closed
3.	Toggle switch	ice position
4.	Compressor	on
5.	Primary power to transformer	yes
6.	Ice Sensor Relay	energized
A)	Ice Sensor relay contact #6	closed
1.	Hot gas solenoid	energized
2.	Dump valve solenoid	energized
B)	Ice Sensor Relay contact #3	closed
	(water pump circuit during harvest cycle)	
C)	Ice Sensor Relay contact #5	open
1.	Fan motor (air cooled models)	off
2.	Water pump delay timer	S.C.R. switch open
D)	Water Pump (through Ice Sensor Relay contact #3)	on
7.	7-Second Delay Timer	not energized
A)	S.C.R. switch	closed
B)	Contactor	energized

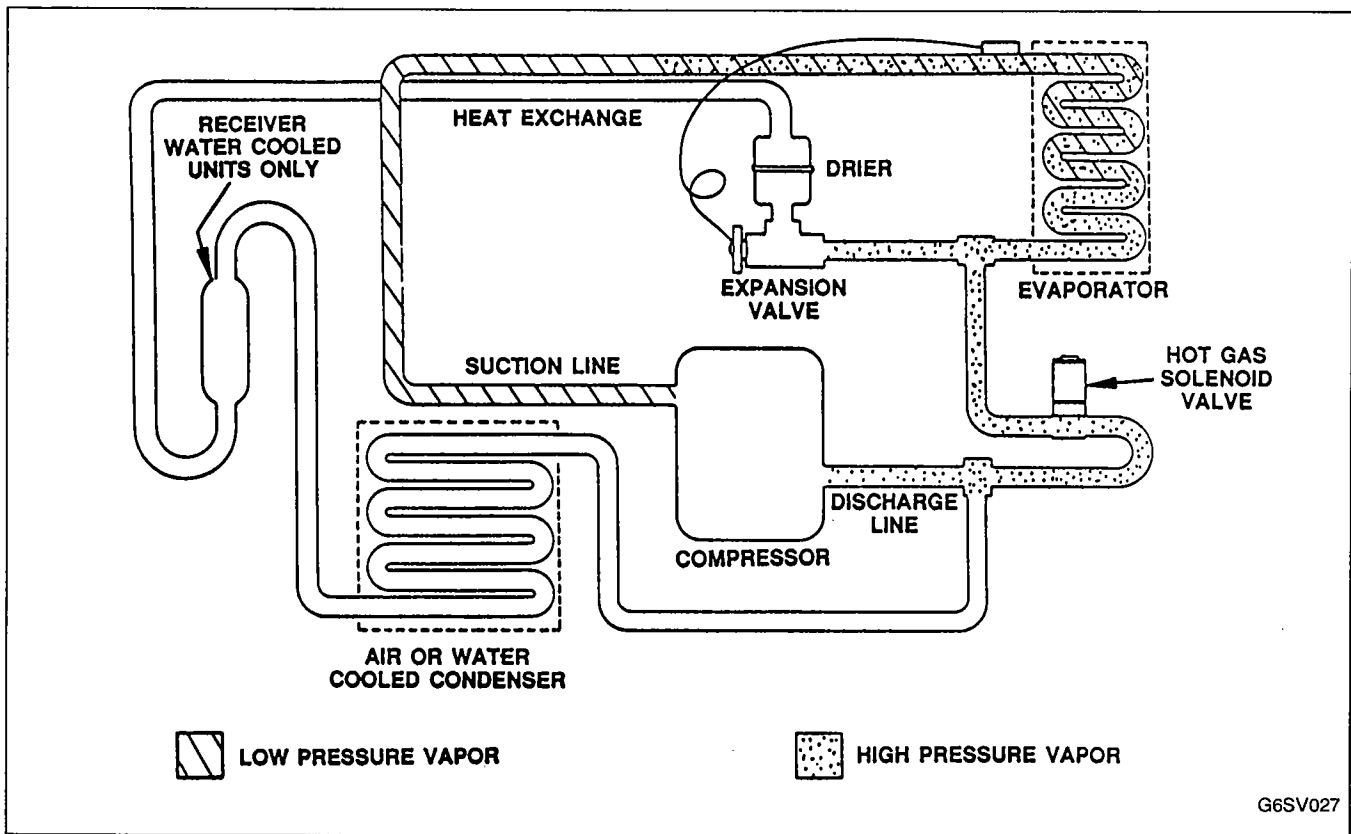

FIGURE 27. HARVEST CYCLE REFRIGERATION SEQUENCE

Harvest Cycle Refrigeration Sequence

Hot gas flows through the energized hot gas valve heating the evaporator. The hot gas valve is sized to allow the proper amount of refrigerant into the evaporator. This specific sizing assures proper heat transfer without the refrigerant condensing and slugging the compressor.

Harvest Cycle Water Flow Sequence

The water from the sump trough is pumped through the energized dump valve and down the drain. The flushing of the minerals after each freeze cycle helps to keep the cubes clear and reduces the frequency of the ice machine cleanings.

HARVEST CYCLE PRESSURES

Ambient Temp. °F	Head Pressure PSI	Suction Pressure PSI
Air Cooled		
50	120-150	55-80
70	140-170	65-80
80	160-180	70-85
90	170-200	85-100
100	200-220	100-115
Water Cooled		
50	130-160	70-85
70	140-160	70-85
80	150-170	70-85
90	150-170	70-85
100	155-175	75-90

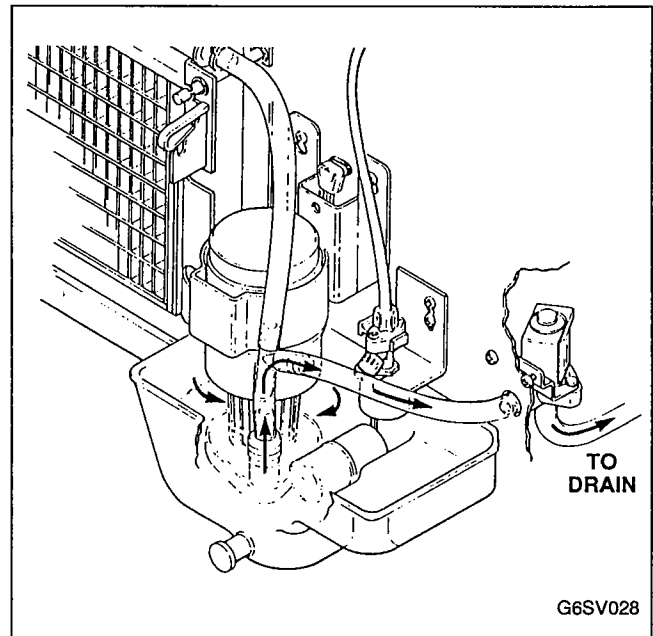

FIGURE 28. HARVEST CYCLE WATER FLOW SEQUENCE

AUTOMATIC SHUT-OFF (Self-Contained Air or Water Cooled) (Full Bin of Ice)

When the ice storage bin becomes full, the last harvesting of ice cubes does not completely clear the water curtain, holding it open. The bin switch opens energizing the compressor off-delay timer. After 7 seconds the timer opens its normally closed switching position (S.C.R.) thus de-energizing the contactor, compressor, water pump, and condenser fan motor.

The 7-second off-delay timer remains energized while the ice machine is off. The ice machine remains off until sufficient ice is removed from the bin allowing ice to clear the water curtain. The return of the water curtain closes the bin switch, de-energizing the 7-second delay timer and energizing the contactor to initiate a new ice making cycle.

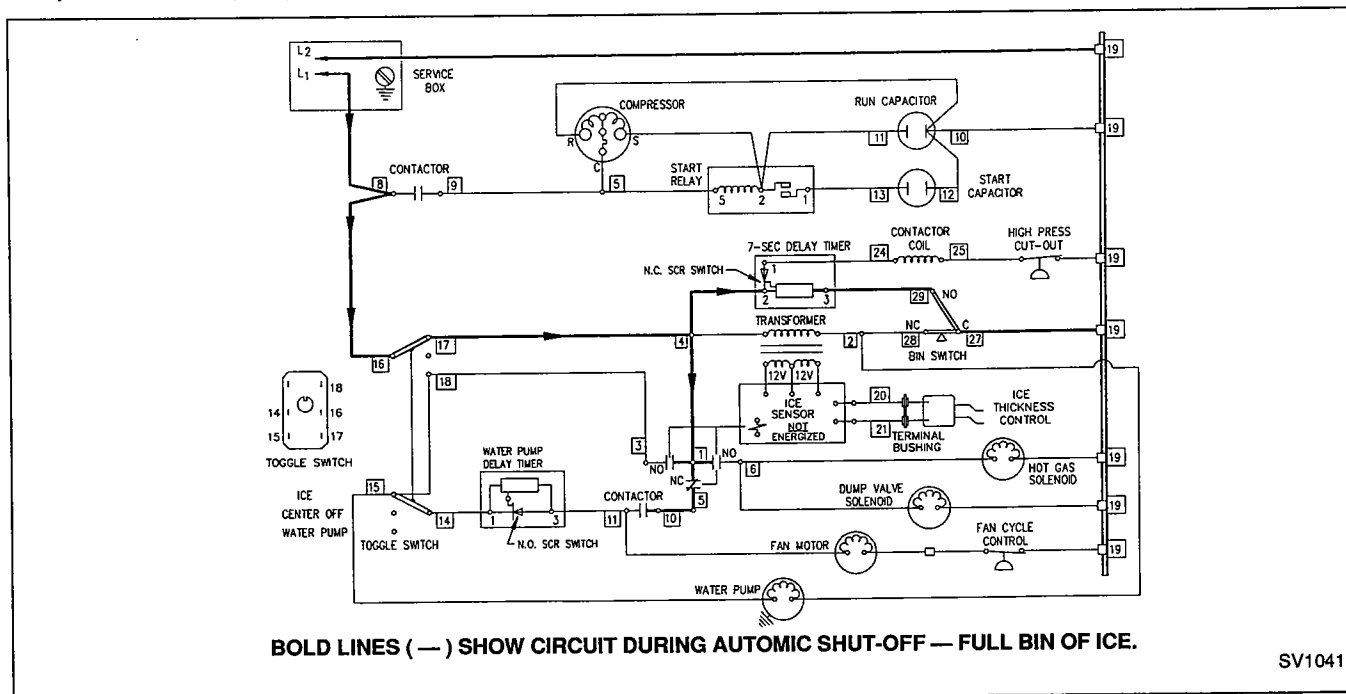

FIGURE 29. AUTOMATIC SHUT-OFF ELECTRICAL SEQUENCE

Automatic Shut-Off Electrical Sequence

1. Bin switch	open
2. High Pressure Cut-Out Control	closed
3. Toggle switch	ice position
4. Compressor	off
5. Primary power to transformer	no
6. Ice Sensor Relay	not energized
A) Ice Sensor Relay contact #6	open
1. Hot gas solenoid	off
2. Dump valve solenoid	off
B) Ice Sensor Relay contact #3 (water pump circuit during harvest cycle)	open
C) Ice Sensor Relay contact #5	closed
1. Fan motor (air-cooled models)	off
2. Water pump delay timer	S.C.R. switch open
D) Water Pump	off
7. 7-Second Delay Timer	energized
A) S.C.R. switch	open
B) Contactor	not energized

Automatic Shut-Off Refrigeration Sequence

The refrigeration system does not operate.

Automatic Shut-Off Water Flow Sequence

The water system does not operate.

SEQUENCE OF OPERATION REMOTE ICE MACHINES

FREEZE CYCLE (Prechill of Evaporator)

At the beginning of the freeze cycle the water pump will not start for 20 seconds.

This allows the evaporator to prechill, minimizing build-up of slush in the sump trough.

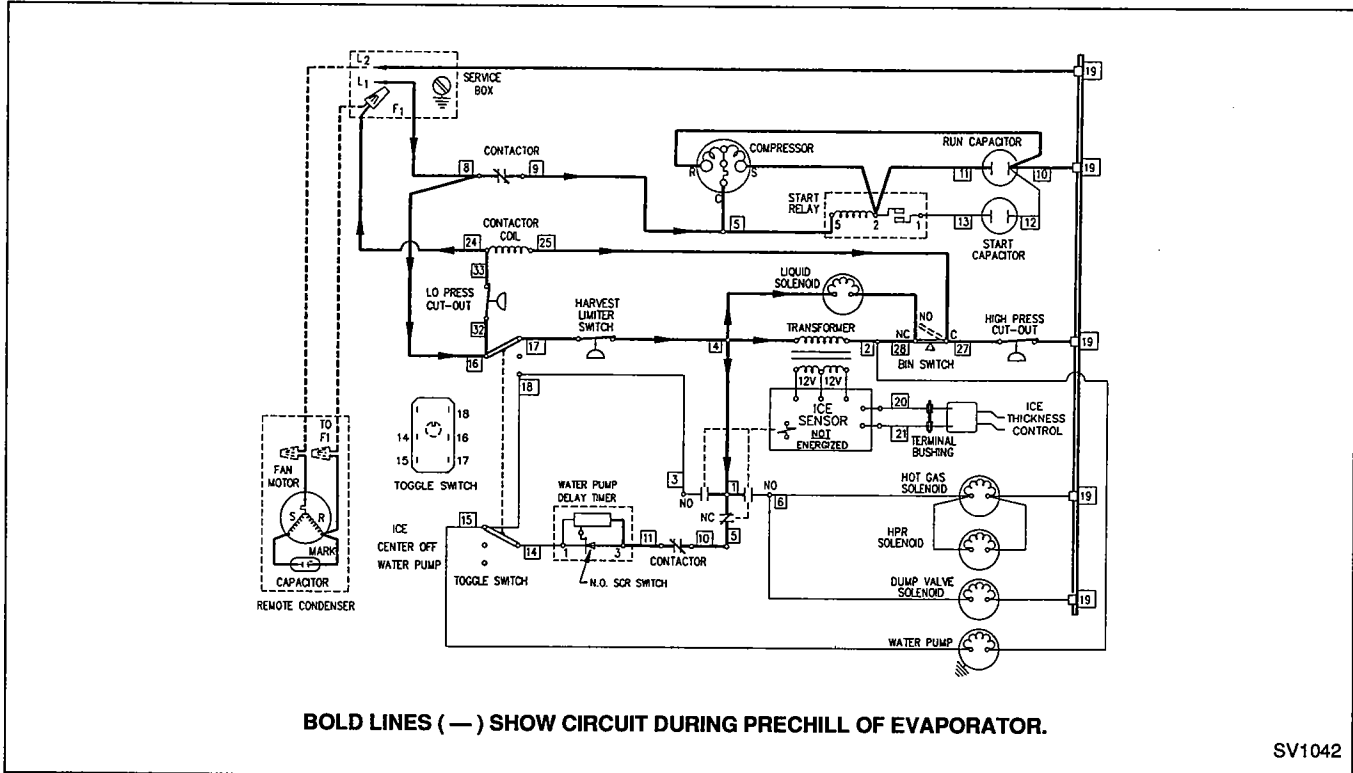

FIGURE 30. PRECHILL ELECTRICAL SEQUENCE

Prechill Electrical Sequence

1. Bin switch	closed
2. High Pressure Cut-Out Control	closed
3. Toggle switch	ice position
4. Liquid Line Solenoid	energized
5. Low Pressure Cut-Out Control	closed
A) Compressor	on
B) Remote fan motor	on
6. Primary power to transformer	yes
7. Harvest Pressure Limiter	closed
8. Ice Sensor Relay	not energized
A) Ice Sensor Relay contact #6	open
1. Hot gas solenoid	off
2. Dump valve solenoid	off
3. H.P.R. solenoid	off
B) Ice Sensor Relay contact #3	open
(water pump circuit during harvest cycle)		
C) Ice Sensor Relay contact #5	closed
1. Water pump delay timer	S.C.R. switch open
(the timer starts a preset 20-second delay period)		
D) Water pump	off
(through Ice Sensor Relay contact #5 and water pump delay timer)		

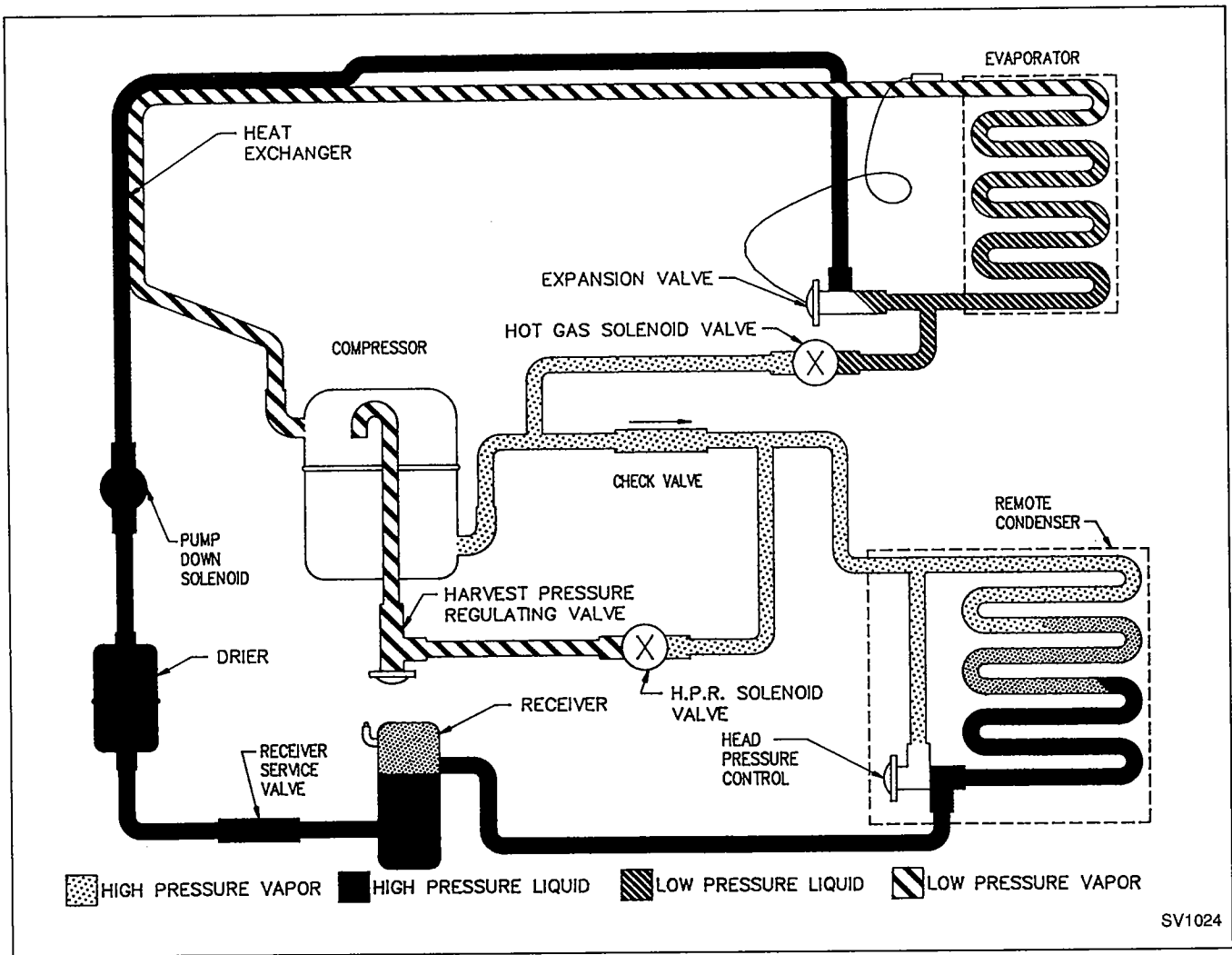

FIGURE 31. PRECHILL REFRIGERATION SEQUENCE

Prechill Refrigeration Sequence

There is no water flow over the evaporator during the prechill. The refrigerant absorbs heat (picked up during the harvest cycle) from the evaporator plate. The suction pressure decreases during prechill.

Prechill Water Flow Sequence

Water does not flow during the prechill.

FREEZE CYCLE (Remote Machines)

The freeze cycle begins when the Water Pump Delay Timer completes the 20-second delay and starts the water pump.

Water flows over the evaporator, forming ice. The freeze cycle will last approximately 10-20 minutes, depending on air and water conditions. (Refer to Cycle Time Chart, page 55.)

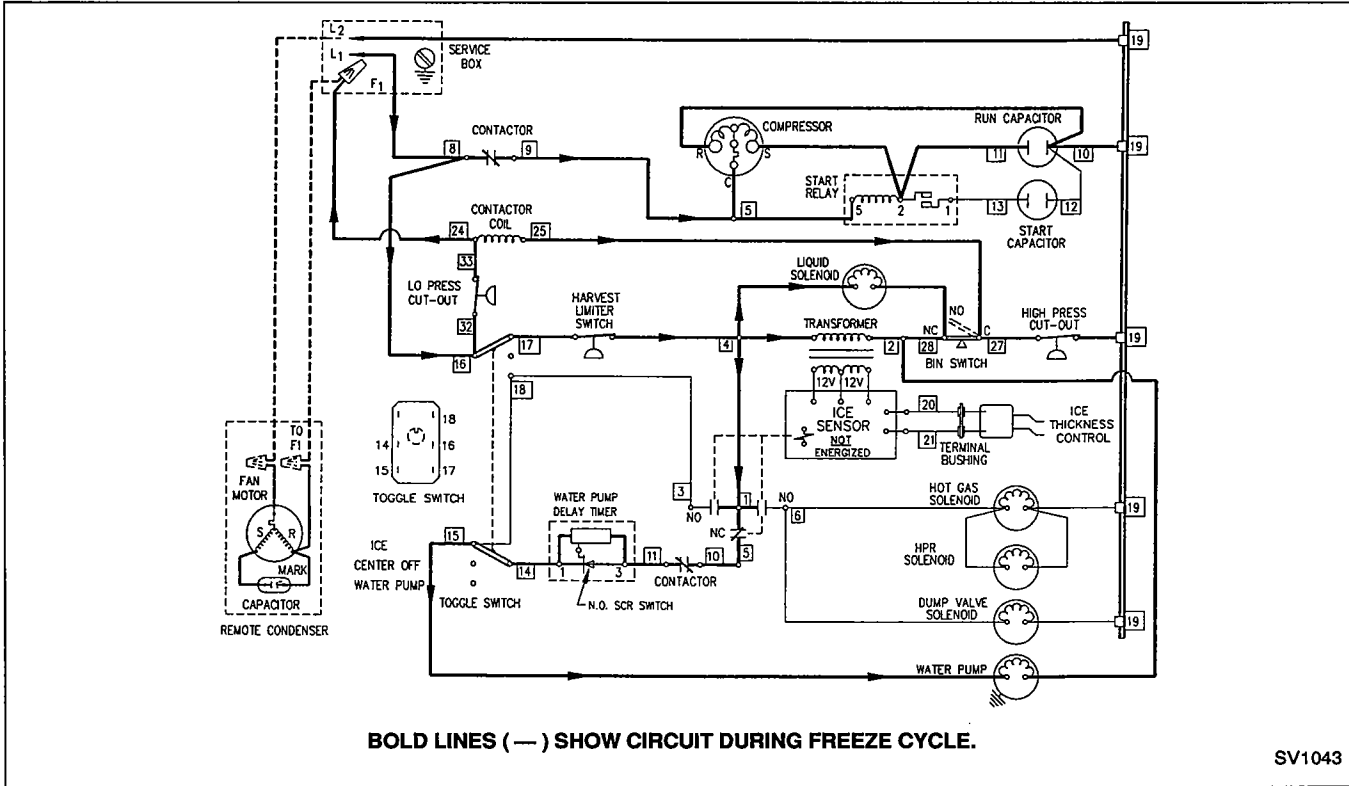

FIGURE 32. FREEZE CYCLE ELECTRICAL SEQUENCE

Freeze Cycle Electrical Sequence

1.	Bin switch	closed
2.	High Pressure Cut-Out Control	closed
3.	Toggle switch	ice position
4.	Liquid Line Solenoid	energized
5.	Low Pressure Cut-Out Control	closed
A)	Compressor	on
B)	Remote fan motor	on
6.	Primary power to transformer	yes
7.	Harvest Pressure Limiter	closed
8.	Ice Sensor Relay	not energized
A)	Ice Sensor Relay contact #6	open
1.	Hot gas solenoid	off
2.	Dump valve solenoid	off
3.	H.P.R. solenoid	off
B)	Ice Sensor Relay contact #3	open
	(water pump circuit during harvest cycle)	
C)	Ice Sensor Relay contact #5	closed
1.	Water pump delay timer	S.C.R. switch closed
D)	Water pump	on
	(through Ice Sensor Relay contact #5 and water pump delay timer)	

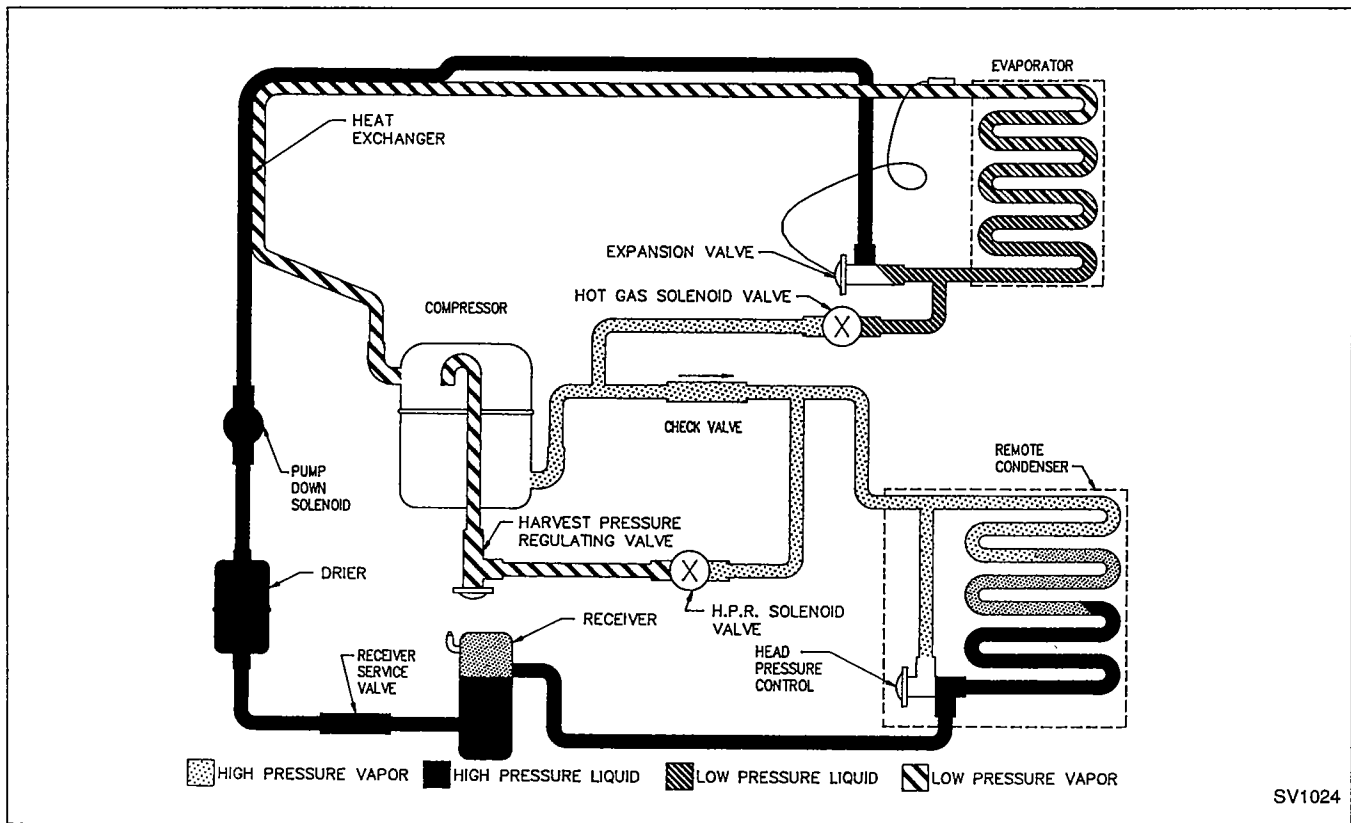

FIGURE 33. FREEZE CYCLE REFRIGERATION SEQUENCE

Freeze Cycle Refrigeration Sequence

The refrigerant is absorbing heat from water running over the evaporator surface. The suction pressure gradually drops as ice forms.

Freeze Cycle Water Flow Sequence

Water from the sump trough is pumped to the distribution tube above the evaporator. It flows evenly over the evaporator to form ice. The float valve maintains proper water level in the sump trough.

REMOTE FREEZE CYCLE PRESSURES

Ambient Temp. °F	Head Pressure PSI	Suction Pressure PSI
-20 to 50	175-195	38-22
70	180-210	38-22
80	210-250	40-24
90	240-280	40-24
100	270-320	42-26
110	300-360	46-28

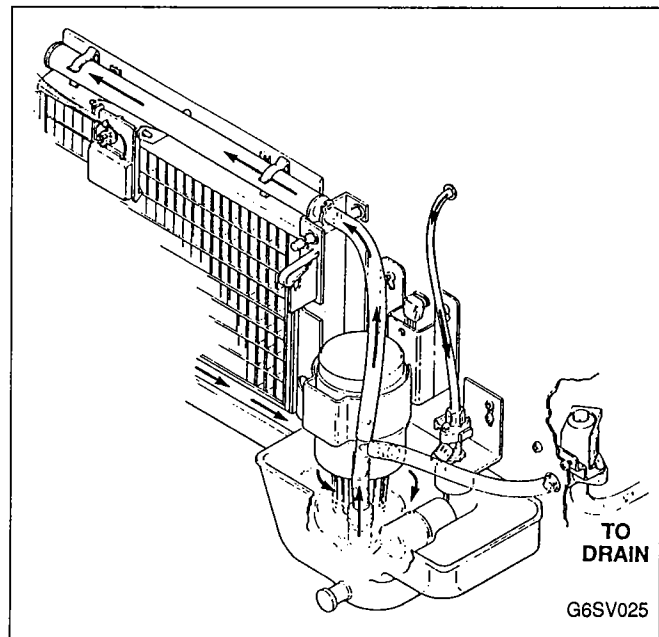

FIGURE 34. FREEZE CYCLE WATER FLOW SEQUENCE

HARVEST CYCLE (Remote Machines)

The harvest cycle begins when water flowing over the ice on the evaporator contacts the probes on the ice thickness control. After a constant 6-10 seconds of water contact, the relay on the ice sensor board is energized, changing contacts #3, #5 and #6.

Water stops flowing over the evaporator and is pumped

through the dump valve. As hot gas warms the evaporator, the ice cubes slide, as a unit, off the evaporator into the storage bin. The harvest cycle will last approximately 1-1/2 to 2 minutes. **Back to freeze cycle prechill:** the falling ice swings the bottom of the water curtain out, momentarily activating (opening) the bin switch. This interrupts the primary power supply at the transformer, de-energizing the ice sensor relay on the unitized sensor board.

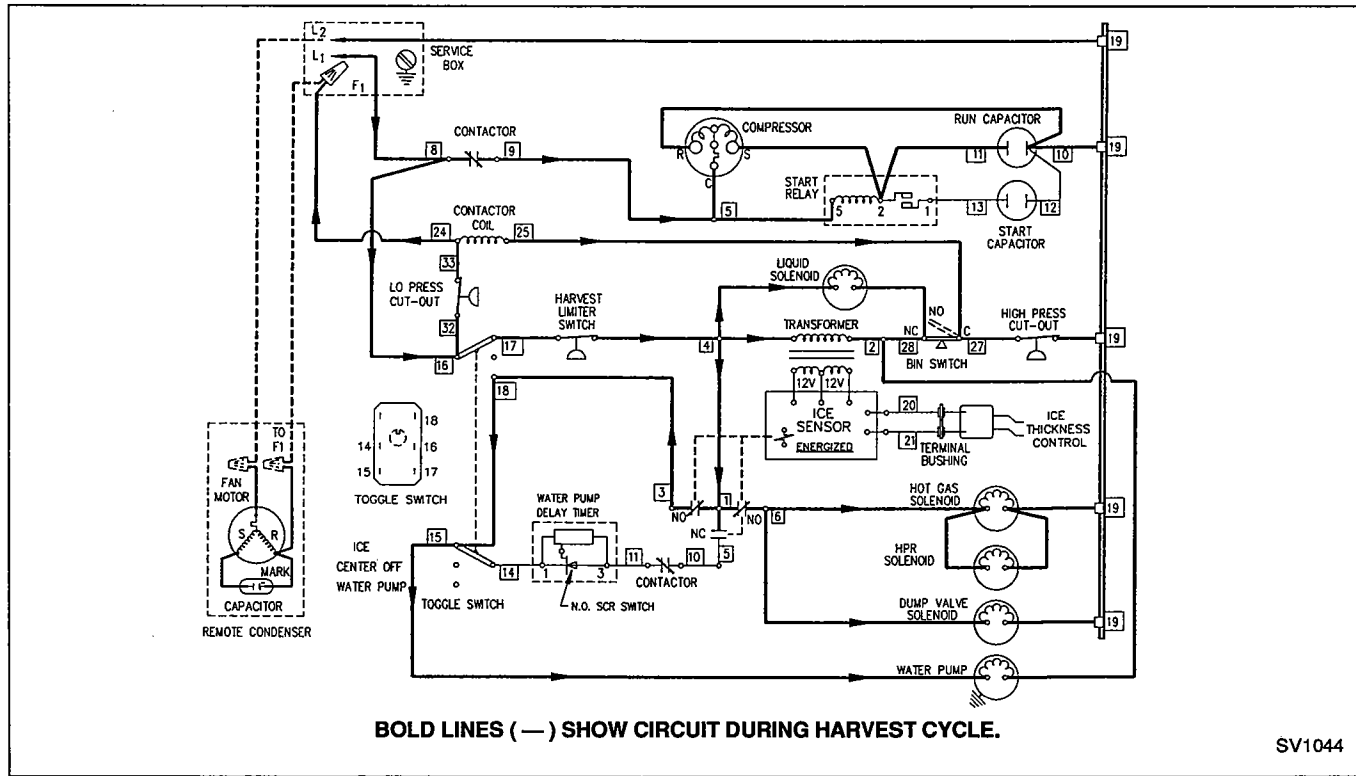

FIGURE 35. HARVEST CYCLE ELECTRICAL SEQUENCE

Harvest Cycle Electrical Sequence

1. Bin switch	closed
2. High Pressure Cut-Out Control	closed
3. Toggle switch	ice position
4. Liquid Line Solenoid	energized
5. Low Pressure Cut-Out Control	closed
A) Compressor	on
B) Remote fan motor	on
6. Primary power to transformer	yes
7. Harvest Pressure Limiter	closed
8. Ice Sensor Relay	energized
A) Ice Sensor Relay contact #6	closed
1. Hot gas solenoid	energized
2. Dump valve solenoid	energized
3. H.P.R. solenoid	energized
B) Ice Sensor Relay contact #3 (water pump circuit during harvest cycle)	closed
C) Ice Sensor Relay contact #5	open
1. Water pump delay timer	S.C.R. switch open
D) Water pump (through Ice Sensor Relay contact #3)	on

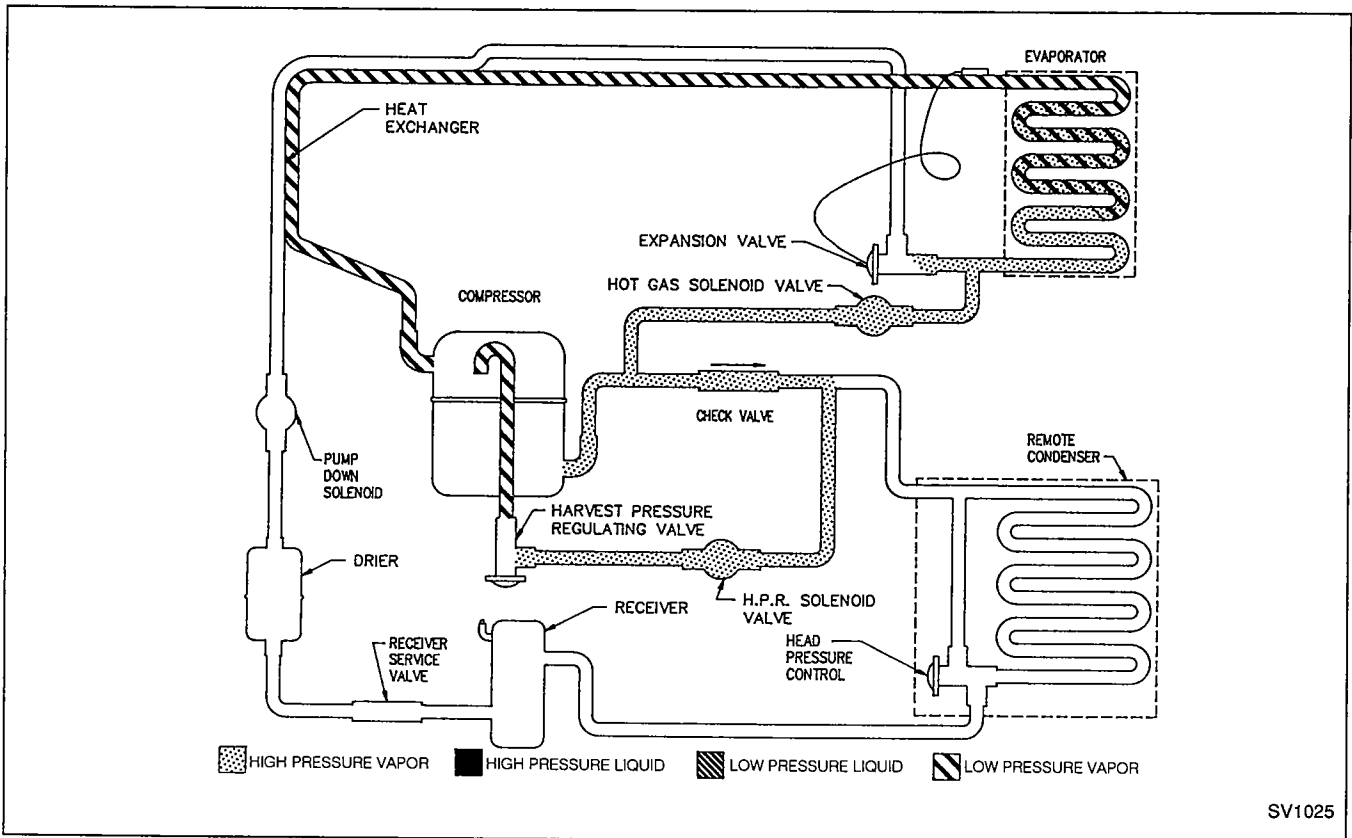

FIGURE 36. HARVEST CYCLE REFRIGERATION SEQUENCE

Harvest Cycle Refrigeration Sequence

Hot gas flows through the energized hot gas valve heating the evaporator. The hot gas valve is sized to allow the proper amount of refrigerant into the evaporator. This specific sizing assures proper heat transfer without the refrigerant condensing and slugging the compressor.

Harvest Cycle Water Flow Sequence

The water from the sump trough is pumped through the energized dump valve and down the drain. The flushing of the minerals after each freeze cycle helps to keep the cubes clear and reduces the frequency of the ice machine cleanings.

REMOTE HARVEST CYCLE PRESSURES

Ambient Temp. °F	Head Pressure PSI	Suction Pressure PSI
-20 to 50	150-170	75-85
70	150-170	80-90
80	160-180	85-95
90	160-180	85-95
100	170-190	90-100
110	180-200	95-105

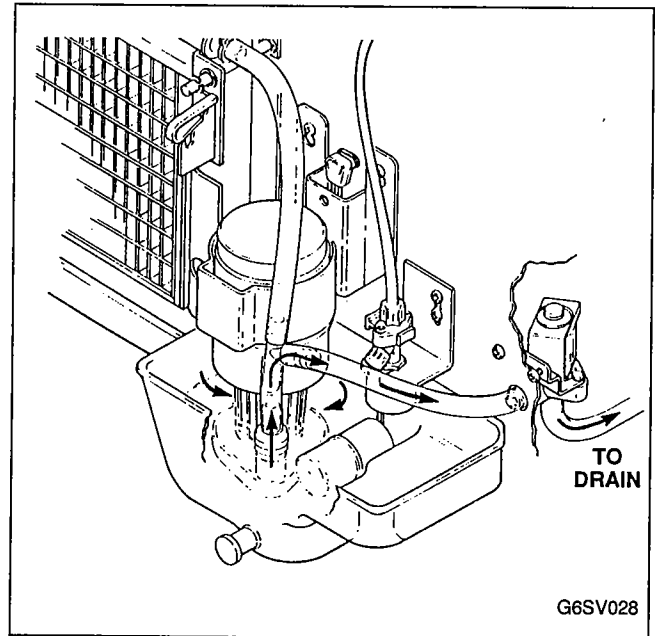

FIGURE 37. HARVEST CYCLE WATER FLOW SEQUENCE

AUTOMATIC SHUT-OFF (Remote Machines) (Full Bin of Ice)

With a full bin of ice the bin switch remains open. This de-energizes the liquid line solenoid valve. The compressor will continue to run and pump down the low side of the ice machine. The low pressure cut-out control opens and de-energizes the contactor, compressor, fan motor, and water pump.

AUTO RESTART

The ice machine will stay off until sufficient ice is removed from the bin, allowing the water curtain to return to the normal position and close the bin switch. Closing the bin switch energizes the liquid line solenoid, raising the low side pressure. This closes the low pressure cut-out control, starting a new freeze cycle.

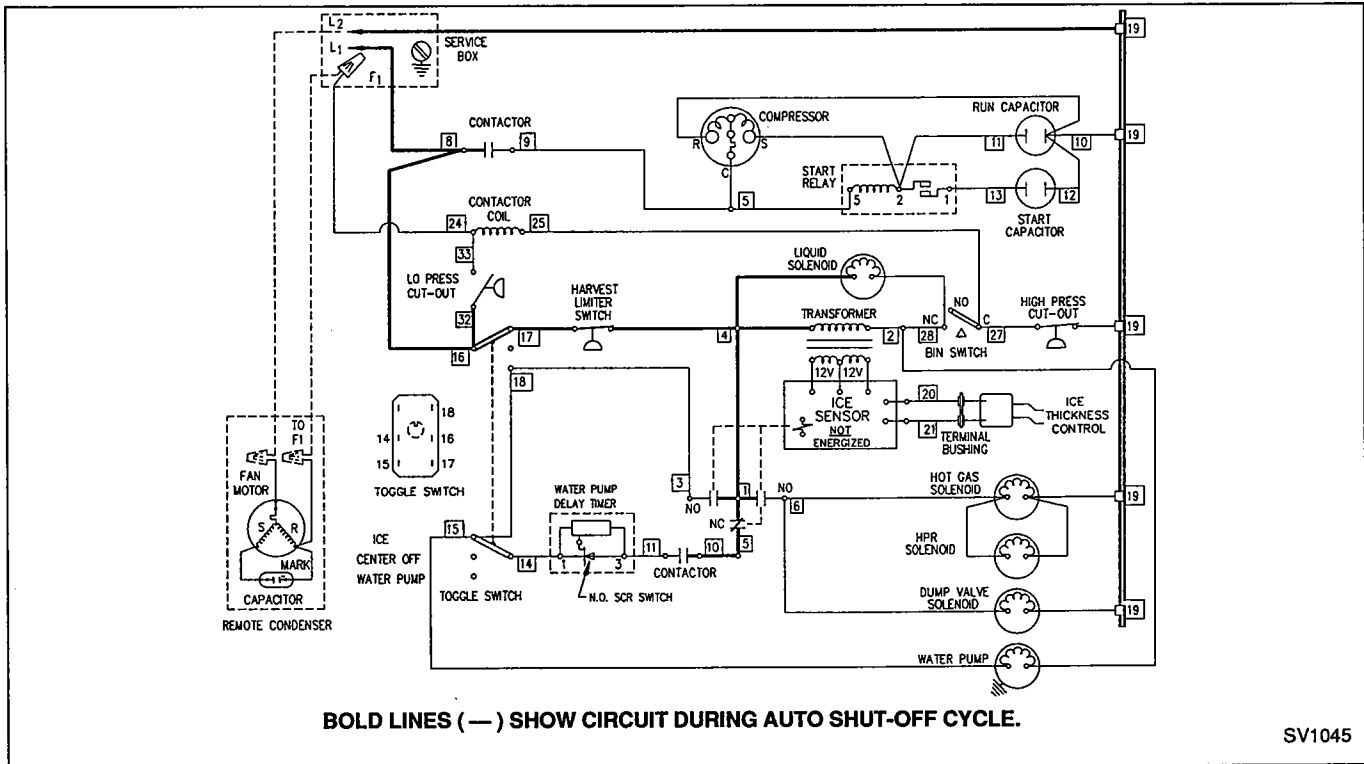

FIGURE 38. AUTOMATIC SHUT-OFF ELECTRICAL SEQUENCE

Automatic Shut-Off Electrical Sequence

1. Bin switch	open
2. High Pressure Cut-Out Control	closed
3. Toggle switch	ice position
4. Liquid Line Solenoid	de-energized
5. Low Pressure Cut-Out control	open
A) Compressor	off
B) Remote fan motor	off
6. Primary power to transformer	no
7. Harvest Pressure Limiter	closed
8. Ice Sensor Relay	non-energized
A) Ice Sensor Relay contact #6	open
1. Hot gas solenoid	off
2. Dump valve solenoid	off
3. H.P.R. solenoid	off
B) Ice Sensor Relay contact #3 (water pump circuit during harvest cycle)	open
C) Ice Sensor Relay contact #5	closed
1. Water pump delay timer	S.C.R. switch open
D) Water pump	off
(through Ice Sensor relay contact #5 and water pump delay timer)	

**AUTOMATIC SHUT-OFF
(Remote Machines)
(Refrigeration Sequence)**

The liquid line solenoid is de-energized and the compressor continues to run. The compressor pumps refrigerant out of the low side of the ice machine and into the high side past the check valve. The low pressure cut-out control opens when the low side pressure reaches 12-17 psi. When the cut-out control opens the compressor is de-energized. With the compressor not operating it is protected from refrigerant migration during the off cycle, preventing refrigerant slogging upon start-up.

IMPORTANT

Do not shut down a remote machine at the circuit breaker panel. The machine will not pump down and de-energize the compressor for off cycle protection. Compressor failure may result when the ice machine is restarted.

**AUTOMATIC SHUT-OFF WATER
FLOW SEQUENCE**

The water system does not operate during the shut-off sequence.

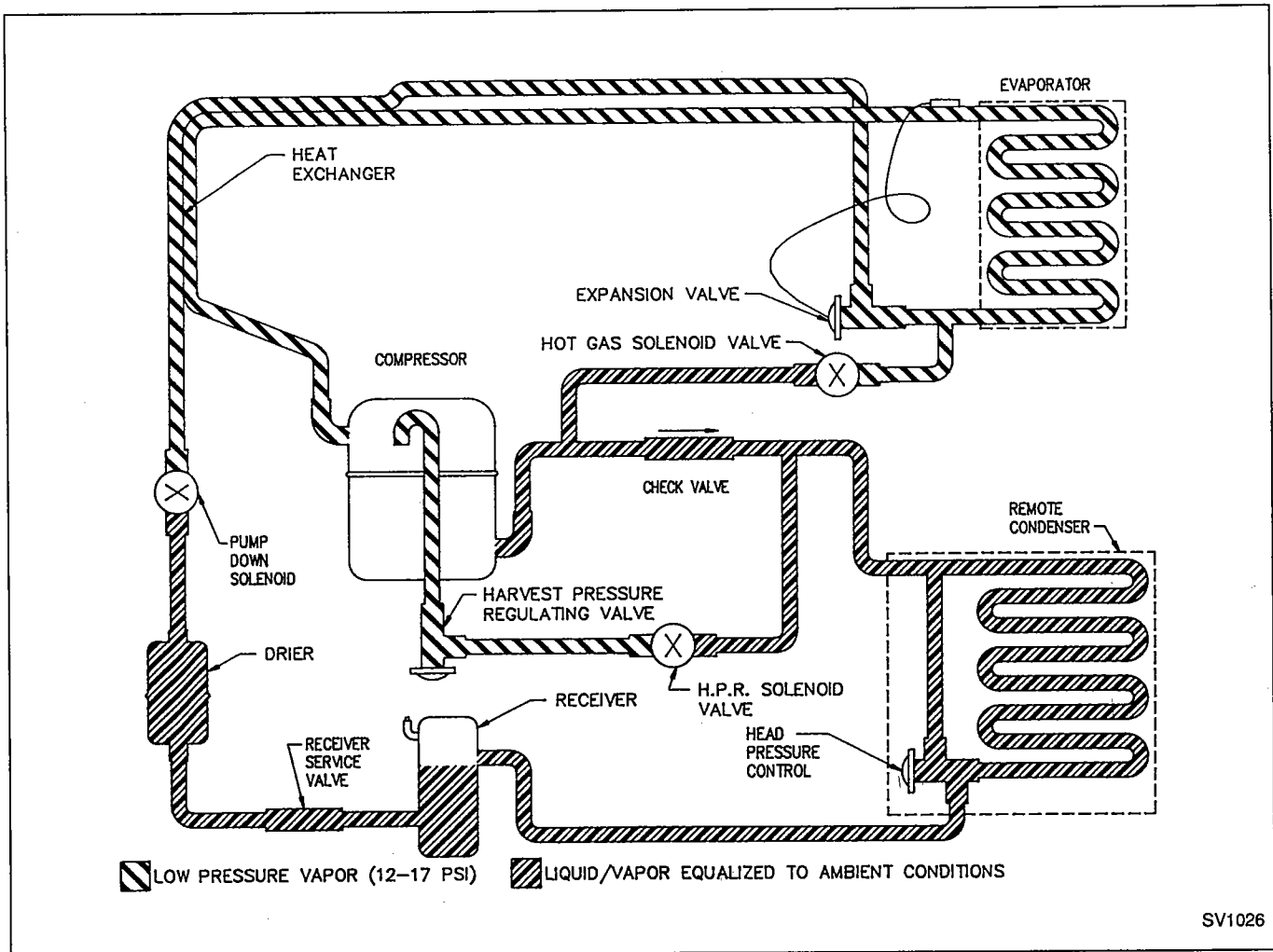

FIGURE 39. AUTOMATIC SHUT-OFF REFRIGERATION SEQUENCE

SERVICE DIAGNOSTIC CHART

Symptom	Possible Cause	Corrective Action
Ice machine will not run.	ICE/OFF/WATER PUMP switch. a. Not in ICE position. b. Defective/miswired.	Set switch at ICE. Check ICE/OFF/WATER PUMP switch, page 40.
	High pressure cut-out control tripped. a. Condenser water pressure low or off (water cooled). b. Condenser water temperature above 90°F (water cooled). c. Dirty condenser (air cooled). d. Refrigerant overcharge. e. High side refrigerant lines or component plugged. f. Headmaster control valve defective. g. H.P.C.O. control defective. Circuit breaker tripped or blown fuse. Bin switch. a. Out of adjustment. b. Defective. Voltage too low. 7-second delay timer defective.	Open water service valve at water condenser inlet. Maintain water supply temperature between 33°F minimum and 90°F maximum. Clean Condenser. Evacuate/recharge, page 69. Repair line/change drier. Check control valve, page 63. Check control, page 39. Reset circuit breaker or replace fuse.
	<u>Remote Machines Only:</u> Liquid line solenoid valve. a. Defective coil. b. Not opening. Refrigeration problem.	Replace coil, page 66. Rebuild/Replace valve, page 66. Refer to Six-Step Diagnostic Procedure, page 51.
Water pump starts before 20-second prechill is completed.	Water pump delay timer. a. Out of adjustment. b. Defective timer.	Readjust to 20 seconds. Check timer, page 42.
Water pump does not start after 20 seconds prechill.	Water pump delay timer defective. ICE/OFF/WATER PUMP switch defective. Water pump defective.	Check timer, page 42. Check ICE/OFF/WATER PUMP switch, page 40. Check water pump, page 41.
Compressor cycles intermittently or will not run.	Voltage too low. Defective start relay. Defective start capacitor. Wiring to compressor Defective compressor.	Electrical service must not fluctuate more than $\pm 10\%$ of nameplate voltage. Check relay, page 49. Check capacitor, page 50. Check for loose connection/miswiring or open and replace. Check compressor, page 49.
	<u>Remote Machines Only:</u> Low pressure cutout control. Refrigeration problem.	Check control, page 44. Refer to Six-Step Diagnostic Procedure, page 51.

Symptom	Possible Cause	Corrective Action
Fan motor will not start.	Defective fan cycling control. Defective fan motor.	Check fan cycling control, page 38. Check fan motor, page 38.
Ice machine will not cycle into harvest.		Refer to page 46 for Diagnostic Procedures.
Ice machine repeatedly cycles into harvest with little or no ice formation.		Refer to page 48 for Diagnostic Procedures.
Ice machine does not cycle from harvest to freeze when ice falls into bin.	Bin switch out of adjustment. Defective bin switch.	Adjust bin switch, page 38. Check bin switch, page 38.
Water runs over evaporator during harvest cycle.	Drain line too small. Water dump valve defective or dirty.	Drain line must be 1/2" I.D. Refer to Checking and Cleaning Water Dump Valve, page 19.
Ice cubes too large/small.	Ice thickness probe out of adjustment.	Adjust ice thickness probe, page 40.
Shallow or incomplete cubes; incomplete ice fill pattern on evaporator.	Ice thickness probe out of adjustment. Ice machine dirty. Water filtration. Ice making water inlet supply too warm. Incorrect incoming water pressure. Leaking water dump valve. Refrigeration problem.	Adjust ice thickness probe, page 40. Clean and sanitize ice machine, refer to pages 14 and 15. Replace filters. Maintain water supply temperature between 33°F minimum and 90°F maximum. Water pressure must be 20-80 psi. Refer to Checking and Cleaning Water Dump Valve, page 19. Refer to Six-Step Diagnostic Procedure, page 51.
Ice machine does not release ice or is slow to harvest.	Ice machine dirty. Air-cooled models — low ambient. Water regulating valve leaking during harvest cycle (water-cooled models). R.T.V. sealant between white plastic and metal evaporator missing.	Clean and sanitize ice machine. Refer to pages 14 and 15. Minimum ambient is 35°F. Clean water regulating valve and condenser. Reseal with food grade R.T.V. sealant.
Low ice capacity.		Refer to Six-Step Diagnostic Procedure, page 51.

COMPONENT FUNCTION, SPECIFICATIONS AND CHECK PROCEDURES

BIN SWITCH

Function

Bin switch operation is controlled by movement of the water curtain (refer to Water Curtain, page 41). It resets ice machine to the freeze cycle by momentarily interrupting power to the transformer board as ice falls from the evaporator. The bin switch also energizes the 7-second delay timer to shut the machine off when the bin is full.

Specifications

Single pole/single throw, normally closed.

Check Procedure

1. Pull water curtain away from evaporator until ice machine shuts off, Figure 40. (Remote machines, wait for ice machine to pump down.)
2. Slowly return curtain to evaporator. Ice machine should restart as bottom edge of water curtain passes just inside edge of water trough. (Remote machines, bin switch energizes Liquid Line Solenoid.)
3. If bin switch adjustment is necessary, adjust as follows:
 - a. Set ICE/OFF/WATER PUMP switch at OFF.
 - b. Slowly pull bottom of water curtain away from evaporator until bin switch clicks, then slowly return curtain toward evaporator.
 - c. If bin switch clicks before water curtain reaches water trough, lengthen the bin switch activating pin, step 4b.
 - d. If bin switch clicks when curtain is too far toward evaporator, shorten the bin switch activating pin.
 - e. Set ICE/OFF/WATER PUMP switch at ICE after adjustment is complete.
4. Bin switch pin adjustment (see Figure 40):
 - a. Loosen brass nut.
 - b. Turn end of pin closest to water curtain counterclockwise to lengthen, clockwise to shorten.
 - c. Tighten brass nut after adjustment and repeat Check Procedure.
5. If bin switch does not operate properly after adjustment, check bin switch with Ohmmeter and/or voltmeter while depressing and releasing activating pin. If bin switch does not open and close properly, replace switch.

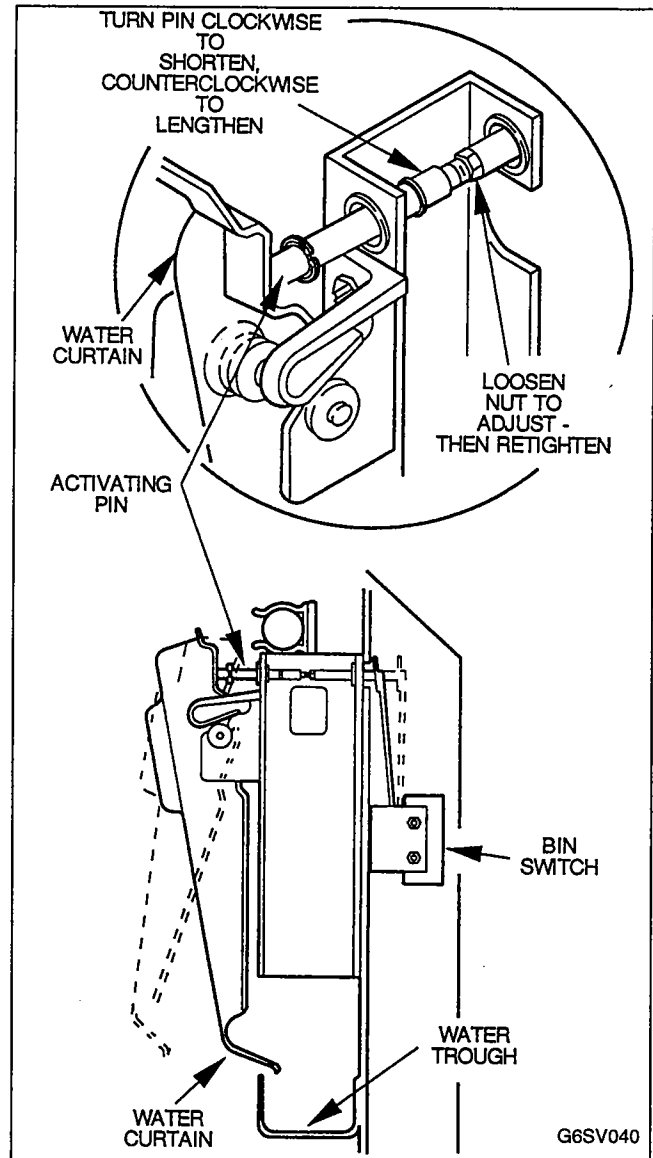

FIGURE 40. BIN SWITCH ACTIVATING PIN ADJUSTMENT

FAN CYCLE CONTROL (Self-Contained Air-Cooled Models)

Function

Cycles fan motor on and off to maintain proper operating discharge pressure.

The fan cycle control is normally closed and opens on a drop in discharge pressure.

Specifications

Cut-out — 175 psi.

Cut-in — 225 psi.

Check Procedures

1. Verify fan motor windings are not open or grounded and fan spins freely.
2. Connect manifold gauges to ice machine. Refer to page 64.
3. Hook voltmeter in parallel (across) to the fan cycle control, leaving wires attached.
4. Pressure above 225 psi — read 0 volts and fan should be running.

Pressure below 175 psi — read line voltage and fan should be off.

Replace Fan Cycle Control if:
Control does not operate within psi range listed above.

FLOAT VALVE

Function

Maintains correct water level in water trough.

Check Procedure

1. Set ICE/OFF/WATER PUMP switch at OFF.

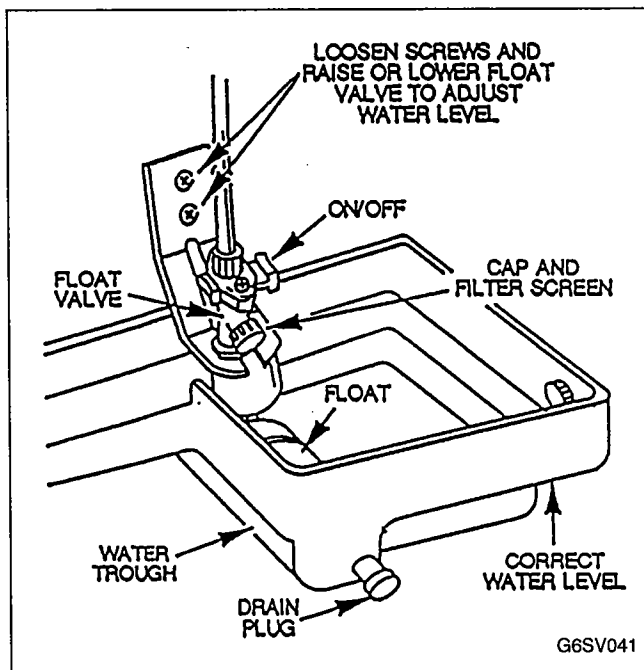

FIGURE 41. FLOAT VALVE CHECK

2. Remove drain plug from trough and allow water to drain. See Figure 41.

3. Reinstall drain plug on trough and allow trough to refill to proper level.

The float valve is factory set to maintain correct water level. If adjustment is necessary, proceed as follows:

- a. Loosen two screws on float valve bracket.
- b. Raise or lower float valve assembly, then tighten screws.
- c. If further adjustment is necessary, carefully bend float arm to achieve correct level.
- d. If float valve cannot be adjusted to maintain correct water level in trough, disassemble and clean before replacement.

HIGH PRESSURE CUT-OUT CONTROL — H.P.C.O.

Function

Safety control which turns the ice machine off if subjected to excessive high-side pressure. The H.P.C.O. control is a normally closed control and opens on a rise in pressure. See Figure 7.

Specifications

Cut-out — 440 psi \pm 10.

Cut-in — manual reset (below 300 psi to reset).

Check Procedure

1. Set ICE/OFF/WATER PUMP switch at OFF and reset H.P.C.O. (if tripped).
2. Hook voltmeter in parallel (across) to the H.P.C.O. leaving wires attached.
3. Connect manifold gauges. Refer to page 64.
4. Procedures:
 - a. Water-Cooled Machines — Close the water service valve to the water condenser inlet. See Typical Installation illustration, page 5.
 - b. Air-Cooled Machines — Disconnect fan motor.
5. Set ICE/OFF/WATER PUMP switch to ICE.

No water or air flowing through the condenser will cause the H.P.C.O. control to turn the ice machine off because of excessive high pressure. Watch the high-pressure gauge and record the pressure at which the cut-out takes place.

Replace the H.P.C.O. control if:

1. The control will not reset. (Note: High-side pressure must be below 300 psi before resetting.)
2. The control does not open at the specified cut-out point of 440 psi \pm 10.

ICE THICKNESS PROBE

Function

Maintain correct ice thickness.

Check Procedure

Verify that wire connections are clean and tight. Inspect bridge connecting the cubes. The ice thickness probe is factory set to maintain 1/8-inch ice thickness. If adjustment is necessary, proceed as follows:

3. Turn adjustment screw (Figure 42) on ice thickness probe clockwise to increase ice thickness, counter-clockwise to decrease ice thickness.

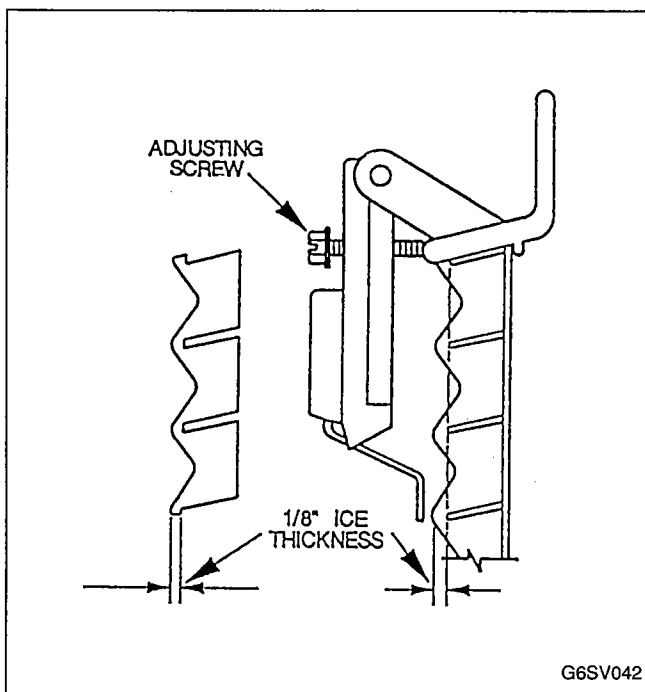

FIGURE 42. ICE THICKNESS CHECK

NOTE

Do not turn more than 1/4 turn at a time. Check ice at least two harvest cycles after initial adjustment before adjusting again (if necessary).

4. Ensure ice thickness probe wires and bracket do not restrict movement of probe.
5. If probe does not maintain correct ice thickness, refer to diagnosing Electronic Control Circuitry, page 46.

ICE/OFF/WATER PUMP TOGGLE SWITCH

Function

Place ice machine in ICE, OFF, or WATER PUMP mode of operation.

Specifications

Single pole/double throw.

Check Procedure

1. Check for proper line voltage to the ice machine ($\pm 10\%$).
2. Inspect switch (Figure 43) for correct wiring.
3. Inspect terminals for clean, tight connections.
4. Check across switch terminals with voltmeter for correct readings as follows (replace switch if readings are incorrect):
 - a. Switch set at ICE.
 - 16 to 17 — 0 volts (closed)
 - 16 to 18 — line voltage (open)
 - 14 to 15 — 0 volts (closed)
 - b. Switch set at OFF.
 - 16 to 17 — line voltage (open)
 - 16 to 18 — line voltage (open)
 - 14 to 15 — line voltage (open)
 - c. Switch set at WATER PUMP.
 - 16 to 17 — line voltage (open)
 - 16 to 18 — 0 volts (closed)
 - 14 to 15 — line voltage (open)

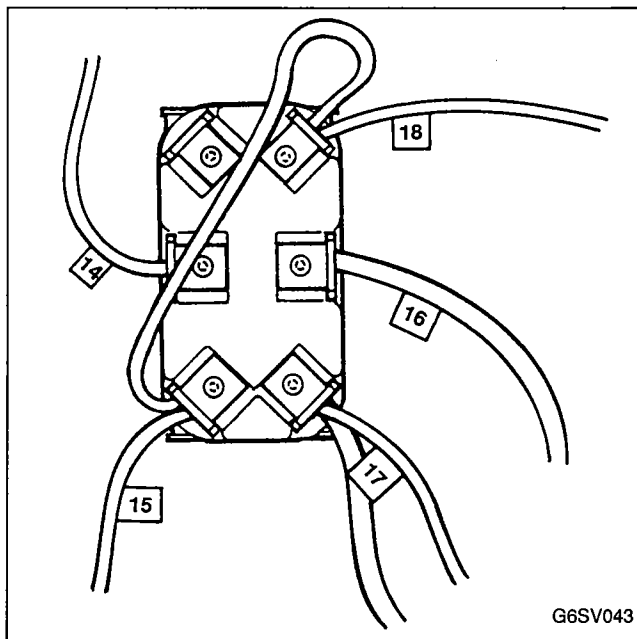

FIGURE 43. ICE/OFF/WATER PUMP SWITCH CHECK

WATER CURTAIN

Function

1. Prevents water from splashing into bin.
2. Acts as a lever to depress and release bin switch activating pin (refer to Bin Switch, page 38) as ice falls from the evaporator.

Check Procedure

1. Pull bottom of water curtain (Figure 44) away from evaporator, then release. Curtain should fall back to evaporator.

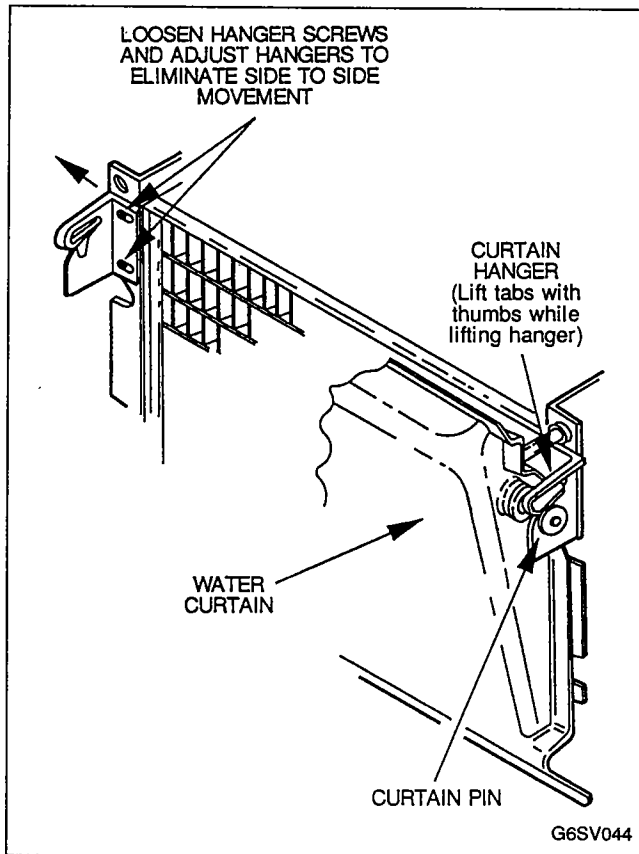

FIGURE 44. WATER CURTAIN CHECK

2. Move curtain from side to side. There should be little or no movement.

The water curtain is factory set and should require no adjustment. If adjustment is necessary, adjust as follows:

- a. Remove water curtain.
- b. Loosen curtain hanger screws (two per hanger) and slide hangers in or out to prevent side to side movement.
- c. Retighten hanger screws.
- d. Reinstall water curtain.

NOTE

Water curtain heads must be positioned under curtain hanger tabs. Curtain must be centered on evaporator when installed.

WATER PUMP

Function

1. Pump water over evaporator during freeze cycle.
2. Pump water through the dump valve and down the drain during harvest cycle.

Specifications

Refer to serial number plate for correct voltage and running amps.

Check Procedure

NOTE

Water pump runs quietly with no water in water trough.

Set ICE/OFF/WATER PUMP switch at WATER PUMP. If water pump runs with switch at WATER PUMP and does not run with switch set at ICE, the water pump is operating properly. Check water pump delay timer, page 42, for proper operation.

If water pump will not run with switch set at WATER PUMP, check the following procedures:

1. Check for proper line voltage to the ice machine ($\pm 10\%$).
2. Unplug the water pump, Figure 45.
3. Set ICE/OFF/WATER PUMP switch at WATER PUMP and check voltage at water pump electric plug receptacle, Figure 45.
 - a. Line voltage — replace water pump after verifying pump impeller is not blocked by foreign objects.

NOTE

For proper ice machine operations replace only with Manitowoc original (OEM) water pump designed and sized specifically for this ice machine.

- b. No voltage — check bin switch, page 38 and ICE/OFF/WATER PUMP switch, page 40.

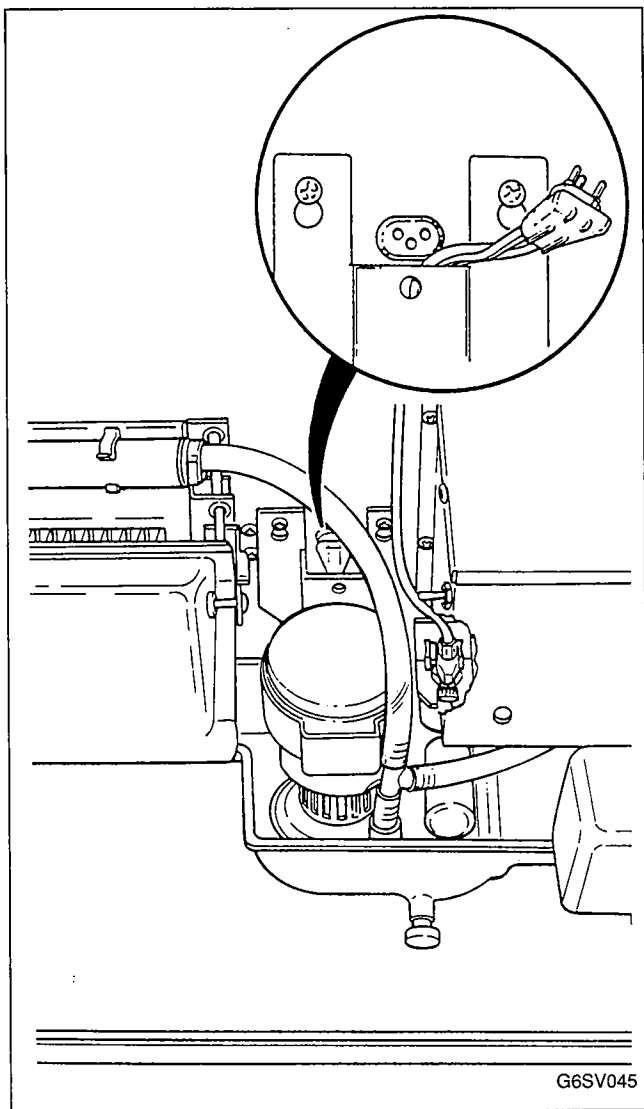

FIGURE 45. WATER PUMP CHECK

G6SV045

WATER PUMP DELAY TIMER

Function

The timer (Figure 7) delays the water pump from starting at the beginning of the freeze cycle, prechilling the evaporator. The timer is adjustable and factory set at 20 seconds.

Specifications

115/220 volt, 50/60 Hertz.
N.O. silicon rectifier (SCR) switch.

Check Procedure

IMPORTANT

The water pump must be functioning properly to check timer (refer to Water Pump, page 41).

Clip voltmeter leads to terminals No. 1 and No. 3. Keep all wire leads attached. See Figure 46.

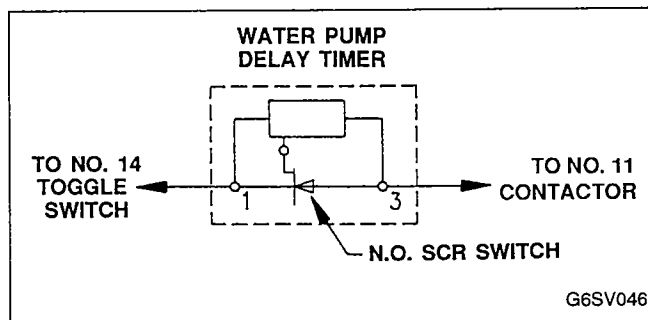

G6SV046

FIGURE 46. WATER PUMP DELAY TIMER CHECK

Normal Operational Sequence

1st 20 sec. into freeze cycle — Water pump off.
line voltage.

After 20 sec. into freeze cycle — Water pump on.
0 volt (1 to 4 volt bleed is OK).

WATER PUMP DELAY TIMER FAILURE CHART

Symptom	Voltage Terminals #1 and #3	Cause
Water pump does not run.	Continual line voltage.	S.C.R. failed open.
Water pump on. No 20-sec. delay at start of freeze cycle. (May experience slushing in sump trough.)	Continual 0 voltage (or 1-4 volt bleed).	S.C.R. failed closed.
Water pump off or running slow.	Approximately 1/2 line voltage.	S.C.R. failed half-wave.

7-SECOND DELAY TIMER (Self-Contained Air or Water cooled)

Function

The normally closed S.C.R. switch is in series with the contactor and prevents interruption of compressor operation when cycling from the harvest mode to freeze mode. The S.C.R. switch will open and de-energize the contactor, shutting the ice machine off when the bin switch is tripped for longer than 7 seconds, as with a full bin of ice. The ice machine will remain off until removal of ice permits the bin switch to return to normal position.

Specifications

208-230 volt, 50/60 Hertz.

Normally closed silicon rectifier (S.C.R.) switch.

Check Procedure

Clip voltmeter leads across S.C.R. switch terminals #1 and #2. Keep all wire leads attached.

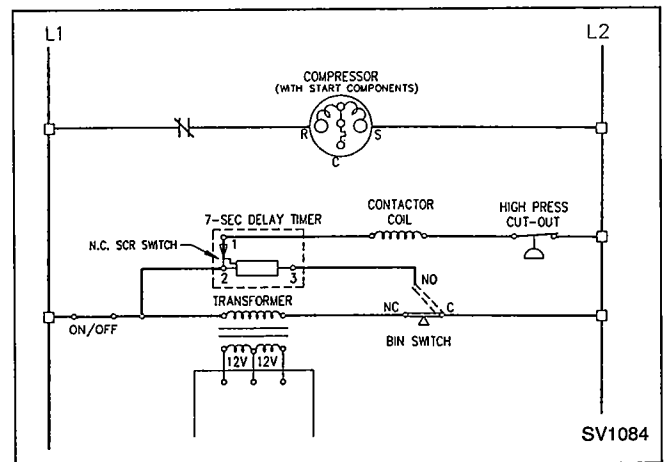

FIGURE 47. 7-SECOND COMPRESSOR DELAY TIMER

NORMAL OPERATIONAL SEQUENCE (No Failure)

No Failure	Voltage Reading Terminals #1 and #2
Bin Empty	0-4 Volts
Bin Full (bin switch tripped for 7 seconds)	Line Voltage

7-SECOND DELAY TIMER FAILURE CHART

Symptom	Voltage Terminals #1 and #2	Cause
Ice machine will not start, no voltage at contactor coil.	Line voltage.	S.C.R. switch is failed open and will not close.
The ice machine functions properly with an empty bin. The ice machine does not shut off on a full bin of ice. (Bin switch tripped for 7 seconds.)	0-4 Volts.	S.C.R. switch is failed closed and will not open.
Contactor does not pull in or chatters.	Approximately 1/2 line voltage.	S.C.R. switch is failed half-wave.

LOW PRESSURE CUT-OUT CONTROL (Remote Machines)

Function

1. A drop in suction pressure opens the low pressure cut-out control.
2. Energizes and de-energizes the contactor to start and stop the ice machine.

Specifications

Cut-out — 15 psi \pm 3.

Cut-in — 40 psi \pm 3.

Check Procedure

1. Connect manifold gauges, page 64.
2. Connect a voltmeter in parallel (across) wires leaving the cut-out control.
3. Set toggle switch to OFF position.
4. The liquid line solenoid valve will de-energize and the suction pressure will begin to decrease. The low pressure cut-out control will open at 15 psi (\pm 3). The contactor will de-energize and the voltage across the L.P. cut-out control will be "line voltage."
5. Set toggle switch to ICE position. The liquid line solenoid valve will energize and the suction pressure will rise. The low pressure cut-out control will close at 40 psi (\pm 3). The contactor will energize and the voltage reading across the low pressure cut-out will be "0."
6. Replace the low pressure cut-out control if it does not open and close properly or does not maintain proper settings.

HARVEST PRESSURE LIMITER CONTROL

Function

1. Safety control which cycles the ice machine out of a harvest cycle and returns it to a freeze cycle if suction pressure becomes excessive.
2. The H.P.L. safety control is normally closed and opens on a rise in suction pressure.

Specifications

Cut-out — 175 psi \pm 10.

Cut-in — 125 psi \pm 10.

Check Procedure

1. Connect a voltmeter in parallel (across) the H.P.L. safety control.
2. Connect manifold gauges, page 64.
3. Set toggle switch to OFF position.
4. Pressures:
 - a. When suction pressure rises above 175 psi the H.P.L. safety control must open. The voltmeter must read "line voltage."
 - b. When the suction pressure drops below 125 psi the H.P.L. safety control must close. The voltmeter must read "0" volts.
5. Replace the H.P.L. safety control if it does not open or close properly or does not maintain proper settings.

ELECTRONIC CONTROL CIRCUITRY

The ice machine uses either a transformer board with a plug-in sensor module or a unitized sensor board to control the ice thickness and initiate the harvest cycle. See Figure 48.

The transformer board and sensor module are not available as replacement parts. If either fails, replace both with a unitized sensor board.

Refer to ice machine Sequence of Operation, page 21, for operation of control circuitry.

SENSOR MODULE

The plug-in sensor module has four functions:

1. A relay to energize or de-energize electrical components utilized during the harvest cycle.
2. Electronics to sense when water is in contact with the ice thickness control probe.
3. A 6 to 10 second timer ensuring the water flowing over the evaporator completes an electrical circuit through the ice thickness control probe.

4. A safety timer ensuring the ice machine does not remain in the harvest cycle for longer than 4 to 5 minutes.

TRANSFORMER BOARD

The transformer board reduces line voltage to the sensor module to 12-24 VAC.

UNITIZED SENSOR BOARD

This board combines the functions of the sensor module and transformer board into one assembly.

ICE THICKNESS CONTROL PROBE

The ice thickness control probe adjusts the ice thickness. Water comes into contact with the two probes for 6 to 10 seconds and completes an electrical circuit initiating the harvest cycle.

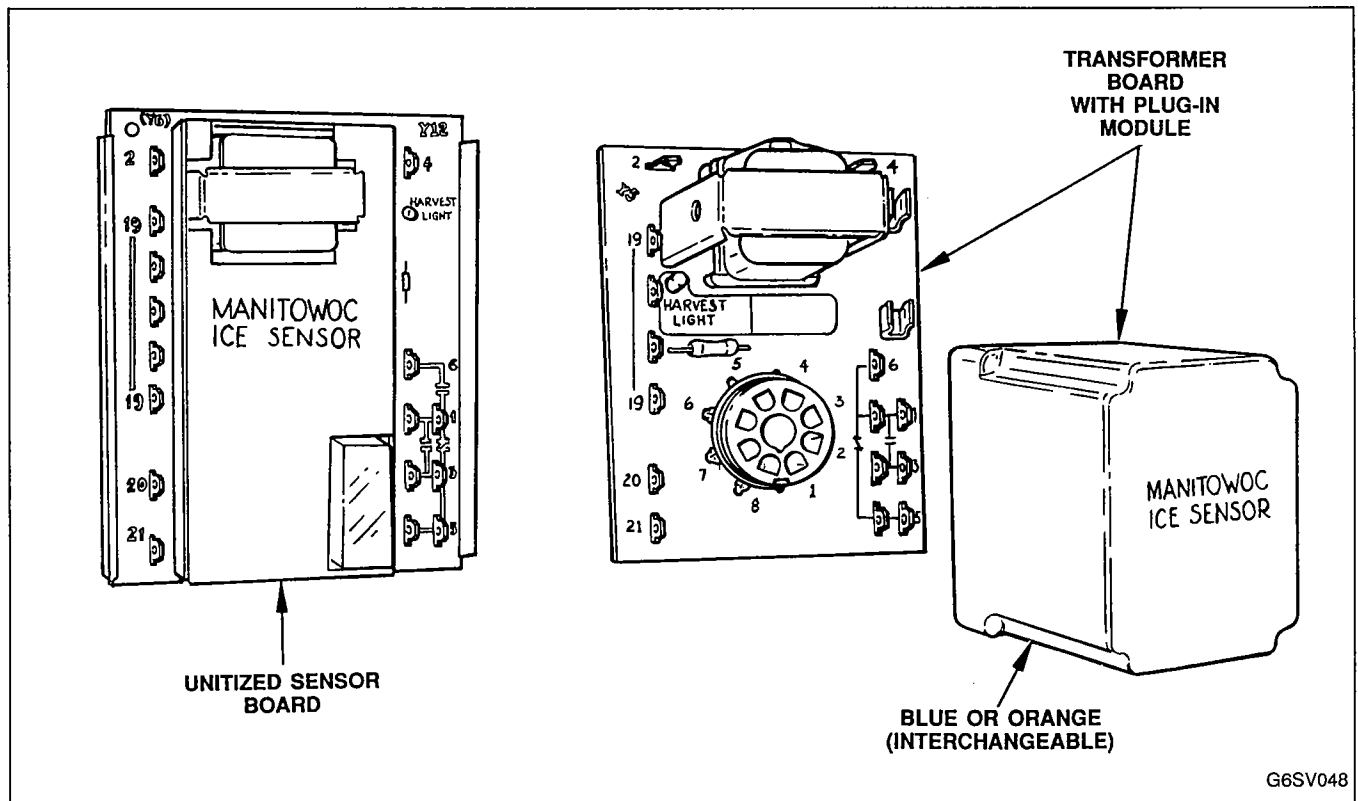

FIGURE 48. ELECTRONIC CONTROLS

DIAGNOSING ELECTRONIC CONTROL CIRCUITRY

IMPORTANT

The transformer board and sensor module are not available as replacement parts. If either fails, replace both with Unitized Sensor Board.



CAUTION

THESE PROCEDURES MUST BE PERFORMED BY A QUALIFIED TECHNICIAN.

Do not make adjustments or turn the ice machine off until the malfunction is identified. The problem may be intermittent and you may lose the opportunity to make the checks while it is malfunctioning.

Follow the systematic approach throughout the diagnosis and write down information as it is collected. This will keep you organized.

A. POSSIBLE PROBLEM: ICE MACHINE WILL NOT GO INTO HARVEST

NOTE

These procedures require the use of a jumper wire with clip ends attached.

Step 1: Check primary voltage at transformer terminals 1 and 2 on board.

Does voltmeter indicate line voltage ($\pm 10\%$)?

IF NO: Check for correct wiring and loose or corroded connections. Also follow control circuitry to check components wired in series with terminals 1 and 2.

Do not proceed until line voltage is restored.

IF YES: Proceed to Step 2.

Step 2: Clip the leads of the jumper wire to the ice thickness control probe, Figure 49.

Does the ice machine go into the harvest cycle?

IF NO: The ice machine still will not harvest. Proceed to Step 3.

IF YES: The entire control circuitry is functioning properly. Check the following:

- Ice thickness probe adjustment, page 40.
- Ice thickness probe has scale build-up acting as an insulator. Clean probe.
- The water to the ice machine may not offer a low enough resistance across the probes for proper operation. To check, put a small amount of salt into water trough to lower the resistance level of the water. If the ice machine goes into harvest after putting salt into the water trough, order Resistor Kit, part number 76-2266-3, from your local Manitowoc Distributor. Install resistor kit across terminals 20 and 21. The ice machine will now operate properly.

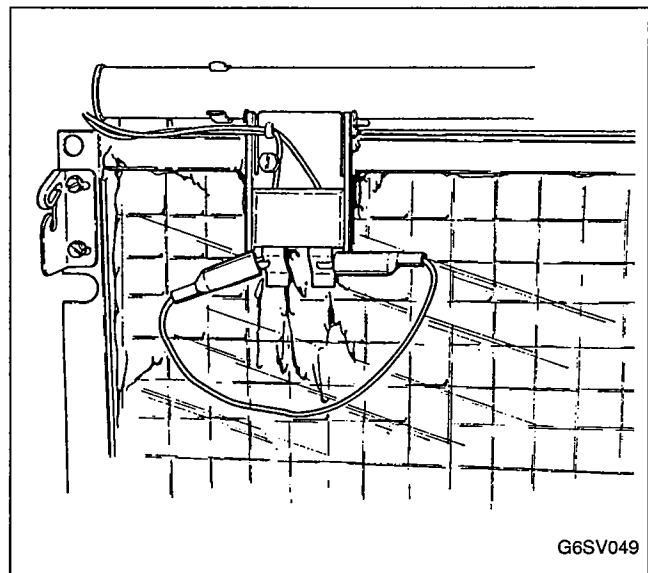

FIGURE 49. JUMPER WIRE CONNECTED TO PROBES

G6SV049

Step 3: Disconnect ice thickness control probe wires from bulkhead (upper left corner). Connect the jumper wire to the bulkhead terminals, Figure 50.

Does the ice machine go into the harvest cycle?

If NO: Proceed to Step 4.

IF YES: The ice thickness probe is the cause of malfunction. All other components are operating properly. The ice thickness probe may be dirty. Attempt to clean before replacing.

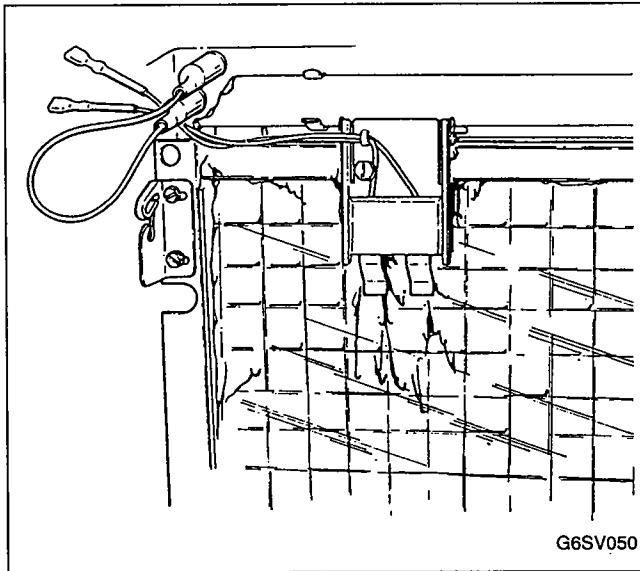

FIGURE 50. JUMPER WIRE CONNECTED TO BULKHEAD TERMINALS

Step 4: Disconnect wires from terminals 20 and 21 on board. Connect jumper wire to terminals 20 and 21, Figure 51.

Does the ice machine go into the harvest cycle?

IF NO: Install new unitized sensor board.

If ice machine you are working on is transformer board/sensor module system, replace both components with unitized sensor board.

IMPORTANT

Failure to check primary voltage (Step 1) can result in a misdiagnosis.

IF YES: The wires between terminals 20 and 21 and the bulkhead are faulty. Check for loose terminals before replacing wires.

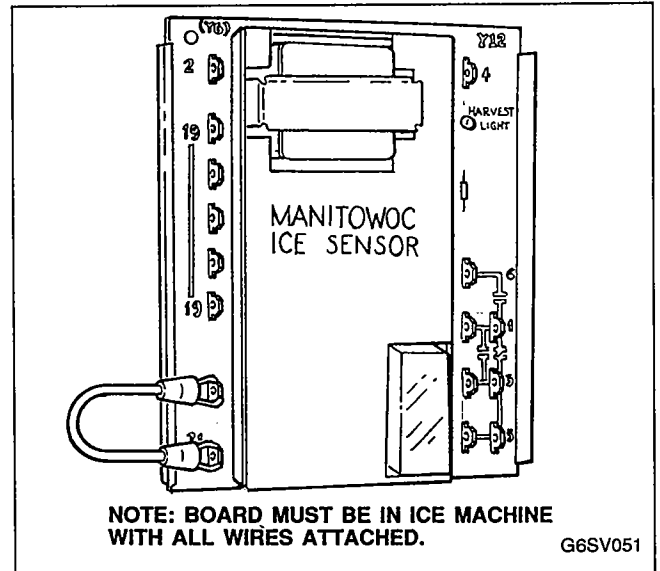

NOTE: BOARD MUST BE IN ICE MACHINE WITH ALL WIRES ATTACHED.

FIGURE 51. UNITIZED SENSOR BOARD

**B. POSSIBLE PROBLEM:
ICE MACHINE PREMATURELY
GOES INTO HARVEST WITHOUT
ICE FORMATION**

Step 1: Check primary voltage at transformer terminals 1 and 2 on board.

Does voltmeter indicate line voltage ($\pm 10\%$)?

IF NO: Check for correct wiring and loose or corroded connections. Also follow control circuitry to check components wired in series with terminals 1 and 2.

Do not proceed until line voltage is restored.

IF YES: Proceed to Step 2.

Step 2: Disconnect ice thickness probe wires from bulkhead, Figure 52. Activate bin switch to cycle the ice machine into the freeze cycle.

Does the ice machine stay in the freeze cycle?

IF NO: Proceed to Step 3.

IF YES: The ice thickness probe is causing the malfunction. All other components are functioning properly. The ice thickness probe may be dirty. Attempt to clean before replacing.

Step 3: Disconnect wires on terminals 20 and 21 on unitized sensor board. Activate bin switch to cycle ice machine into the freeze cycle.

Does the ice machine stay in the freeze cycle?

IF NO: Ensure there is no moisture between terminals 20 and 21 on board. If no moisture, install new unitized sensor board.

If ice machine you are working on has transformer board/sensor module controls, replace both components with unitized sensor board.

IMPORTANT

Failure to check primary voltage (Step 1) can result in a misdiagnosis.

IF YES: Check for moisture where the ice thickness control probe wires connect to the bulkhead. Dry bulkhead terminals and reconnect.

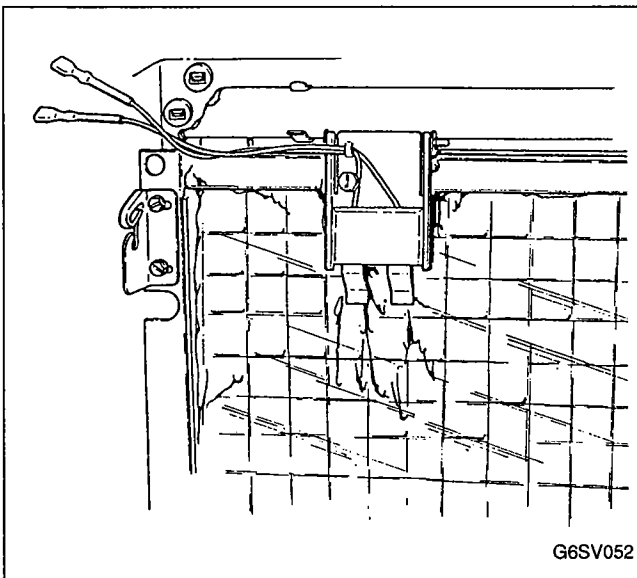

**FIGURE 52. DISCONNECT PROBE WIRES FROM
BULKHEAD TERMINALS**

DIAGNOSING COMPRESSOR AND START COMPONENTS ELECTRICALLY

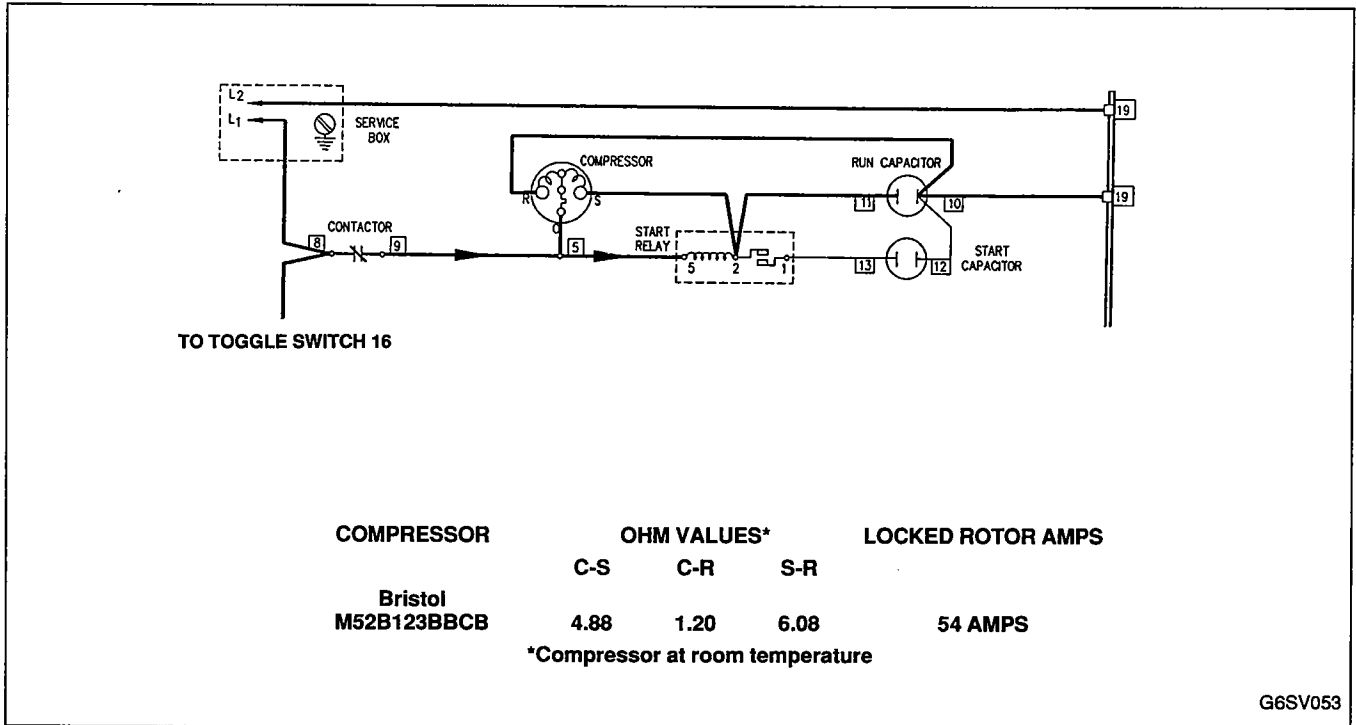

FIGURE 53. COMPRESSOR AND START COMPONENTS SCHEMATIC

Perform the following tests, in sequence, using a quality, calibrated volt-ohmmeter.

1. Verify electric power to the ice machine at time of compressor start-up is 208/230 V ($\pm 10\%$).
2. Verify the following control components are in the closed position:
 - Bin Switch, page 38.
 - High Pressure Cut-Out Control, page 39.
 - ICE/OFF/WATER PUMP Switch, page 40.
 - Contactors, page 43.
 - Compressor Off Delay Timer, page 43.
 - Low Pressure Cut-Out, page 44.

WARNING
DISCONNECT ELECTRIC POWER TO THE ICE MACHINE AT THE ELECTRIC SERVICE SWITCH BOX BEFORE PROCEEDING WITH THE FOLLOWING STEPS.

3. Continuity check of start relay (RX10,000 scale):
 - a. Disconnect wires from start relay. (If relay is being removed, keep it upright.)

- b. Terminals 1 and 2 (contact normally closed).
 No continuity — replace relay.
 Continuity — relay OK.
- c. Terminals 2 and 5.
 No Continuity — replace relay.
 Continuity — relay OK.

4. Continuity check of compressor:

NOTE
 Compressor must be at room temperature.

- a. Disconnect wires from compressor terminals.
- b. Terminal C to Terminal R.
 Continuity — see step e.
 No continuity — open run winding. Replace compressor.
- c. Terminal C to Terminal S.
 Continuity — see step e.
 No continuity — open start winding.
 Replace compressor.
- d. Terminal C to shell of compressor.
 Continuity — compressor grounded.
 Replace compressor.
 No continuity — compressor not grounded.

- e. Check winding resistance against values given in chart. The resistance values from C-R and C-S added together should equal the reading from S to R.
5. Capacitor check (run and start):
- a. Capacitors may show visual evidence of failure, such as a bulged terminal end or a ruptured membrane. However, *do not* assume a capacitor is good just because there are no visual signs of failure.
 - b. An effective test is to disconnect leads to the capacitor in the ice machine and connect them to a good capacitor.
- c. Use of a capacitor analyzer is recommended when checking a suspect capacitor. Follow instructions supplied with capacitor analyzer.
 - d. If all of the capacitor tests prove satisfactory and the compressor still fails to start:
 - 1) Replace start relay.
The new relay eliminates any faulty electrical characteristics such as improper pick-up or drop-out, which cannot be determined by the tests.
 - 2) If new relay fails to correct the problem, the compressor can be considered inoperative because of internal defects. Replace compressor.

REFRIGERATION AND OTHER NON-ELECTRICAL PROBLEMS

INTRODUCTION TO THE SIX-STEP DIAGNOSTIC PROCEDURE

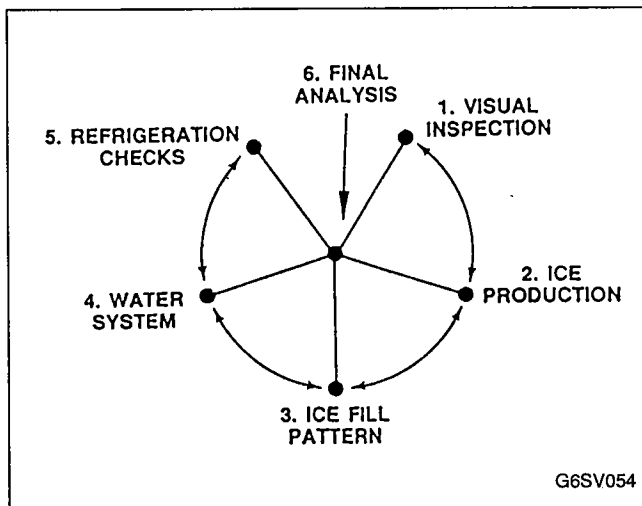

FIGURE 54. SIX-STEP DIAGNOSTIC PROCEDURE

The Six-Step Procedure (Figure 54) is designed to increase the accuracy of your service call, while decreasing the time required to identify any problems.

Refrigeration components will react and try to compensate for nonrefrigeration component problems. By following this procedure step by step, problems that affect the refrigeration sequence can be identified without needless changing of components.

Each of the six steps have several items to check before proceeding to the next step. Follow each step carefully as the problem may be identified prior to the completion of all six steps.

Step 6 requires the use of information gathered in the previous steps. Write down information as you collect it and record it on the Refrigeration Component Diagnostic Chart, page 62. This will keep you organized and simplify the 6th step of determining the malfunction.

NOTE

Do not make adjustments or turn the ice machine off until you have identified the malfunction. The problem may not repeat itself.

STEP 1 — VISUAL INSPECTION

Talk to the ice machine user to identify the perceived problem(s). The user's information could help you start in the right direction and may be a determining factor in your final diagnosis.

Following are a few questions to consider when talking to the ice machine user:

- When is the ice machine malfunctioning? (Night, day, all the time, during freeze cycle, harvest cycle, etc.)

- When do you notice low production? (One day a week, every day, weekends, etc.)
- Can you describe exactly what the ice machine seems to be doing?
- Has anyone been working on the ice machine?
- Were items such as boxes obstructing air flow moved from around the ice machine before you arrived?

EQUIPMENT VISUAL INSPECTION

(Record Your Findings on Refrigeration Component Diagnostic Chart, Page 62.)

Possible Problem	Actual Finding	Corrective Measure
1. Ice machine not properly installed.		Reinstall in accordance with installation manual.
2. Air temperatures/air flow restrictions, etc.		Reinstall in accordance with installation manual.
3. Air space clearances at back and sides of ice machine.		Must have a minimum of 5 inches clearance around all sides and top of machine.
4. Ice machine not level side-to-side, back-to-front.		Level machine.
5. Air-cooled condenser dirty.		Clean condenser.
6. Ice machine not on separate fused electrical circuit.		Install electrical in accordance with installation manual.
7. Drains not run separate and/or vented.		Run drains separate and vent according to installation manual.
8. Water filtration restricted (if used).		Install new water filter.
9. Remote condenser line set not properly installed.		Refer to Installation Instructions.

NOTE

Steps 2, 3 and 4 can be completed in conjunction with each other. Be careful not to interfere with the ice production check.

STEP 2 — ICE PRODUCTION

The amount of ice a machine produces is in direct relationship to water and air temperatures, i.e., an ice machine produces more ice in a 70°F room with 50°F water than in a 90°F room with 70°F water.

ICE PRODUCTION CHARTS (Lbs. of Ice per 24 Hours)

Water-Cooled

Air Temp. °F	Water Temp. °F		
	50	70	90
70	580	500	440
80	570	490	430
90	560	480	420
100	550	480	400

Air-Cooled

Air Temp. °F	Water Temp. °F		
	50	70	90
70	600	520	480
80	560	500	450
90	500	460	400
100	430	380	360

Remote Machines

Air Temp. °F	Water Temp. °F		
	50	70	90
-20 to 70	620	530	480
90	560	480	430
100	500	430	390
110	440	380	350
Based on 70°F air at ice machine			

These figures are based on a clean, properly maintained ice machine running continually for a 24-hour period, with an average ice weight of 4 lb. 2 oz. to 4 lb. 12 oz. per harvest.

Use the following to check and compare ice production:

IMPORTANT

Water curtain must be in place to assure no water is being lost while checking ice production.

OPERATING CONDITIONS

1. Condenser inlet air temperature _____
2. Water inlet temperature (taken at float outlet) _____
3. The published 24-hour ice production at the above conditions: _____ lb/24 hours

ICE PRODUCTION CHECK

1. Freeze time _____ + harvest time _____
= _____ total cycle time
2. $1440 \div$ total cycle time _____
= _____ cycles/day
3. Weight 1 harvest _____ x cycles/day _____
= _____ lb/24 hours

Times are in minutes.

Example: 1 min. 15 sec. convert to 1.25 min.
 $15 \text{ sec.} \div 60 \text{ sec.} = .25 \text{ min.}$

Weights are in pounds.

Example: 4 lb. 2 oz. convert to 4.125 lb.
 $2 \text{ oz.} \div 16 \text{ oz.} = .125 \text{ lb.}$

Compare your findings in the Ice Production Check to published specifications in Operating Conditions. Record your findings on Refrigeration Diagnostic Chart, page 62.

- A. Ice Production OK:**
Determine if another ice machine is needed, more storage capacity, or if moving existing equipment to lower load conditions will meet the customer's needs. (Contact local Manitowoc Distributor for options and accessories available.)
- B. Low Ice Production:**
Continue through Six-Step Procedures.

STEP 3 — ICE FILL PATTERN

The fill pattern on the evaporator is normal when the ice thickness is a uniform 1/8 inch from top to bottom and side to side. (The ice bridge is the inter-connecting waffle between the cubes. Refer to page 40.) The water should freeze on the entire evaporator at the same time. Ice forming on the bottom of the evaporator then working its way up to the top is not normal and must be noted as "thin on top and thick on bottom."

IMPORTANT

The water curtain must be in place to ensure no water is being lost while checking ice fill pattern.

Examples of ice fill patterns:

- Normal ice fill — uniform 1/8-inch bridge thickness on entire evaporator surface.
- Thick on top and thin on bottom.
- Thin on top and thick on bottom.
- Spotty ice fill (i.e., corner not filling, etc.).

Record your findings on the Refrigeration Diagnostic Chart, page 62. (Step 3 actual findings column of chart.)

STEP 4 — WATER SYSTEM

Water related problems in ice machines often have the same symptoms as a refrigeration system malfunction.

Water area failures must be identified and eliminated prior to changing of refrigeration components. An example is a water dump valve leaking during the freeze cycle and a starving TXV. The characteristics of both failures are similar.

CHECK WATER RELATED PROBLEMS

(Record Your Findings on Refrigeration Component Diagnostic Chart, Page 62.)

Possible Problem	Actual Finding	Corrective Measure
1. Water area (evaporator) dirty.		Clean.
2. Water inlet pressure not between 20-80 psi.		Install water regulator valve or increase water pressure.
3. Incoming water supply temperature must be 35°F to 90°F.		Too hot — check hot water line check valves in other store equipment.
4. Water filter restricted (if used).		Replace filter.
5. Dump valve malfunctioning.		Clean dump valve. Replace as needed, page 19.
6. Vent tube not installed on water outlet drain.		See Installation Manual.
7. Water trough hoses leaking water.		Install properly or replace.
8. Water float valve stuck open or out of adjustment.		Readjust float, page 39.
9. Water freezing behind evaporator.		Check water flow.
10. Water freezing between white plastic extrusions and evaporator.		Seal with food-grade silicone (RTV) adhesive.
11. Water flow uneven across evaporator.		Clean ice machine. Check water flow rate.

STEP 5 — REFRIGERATION

The refrigeration section requires taking several checks to gather information.

NOTE

Only proceed to Refrigeration System Step 5 after Steps 1-4 have been thoroughly checked and a final diagnosis could not be determined.

OPERATIONAL PRESSURE CHART

Ambient Temp. °F	Freeze Cycle		Harvest Cycle	
	Head Pressure PSI	Suction Pressure PSI	Head Pressure PSI	Suction Pressure PSI
Water-Cooled				
50	215-225	38-24	130-160	70-85
70	215-225	40-26	140-160	70-85
80	215-225	42-26	150-170	70-85
90	215-225	42-26	150-170	70-85
100	215-225	44-26	155-175	75-90
Air-Cooled				
50	175-220	36-20	120-150	55-80
70	180-225	40-22	140-170	65-80
80	200-250	42-24	160-180	70-85
90	240-280	44-26	170-200	85-100
100	260-300	46-26	200-220	100-115

Remote Machines

Ambient Temp. °F	Freeze Cycle		Harvest Cycle	
	Head Pressure PSI	Suction Pressure PSI	Head Pressure PSI	Suction Pressure PSI
-20 to 50	175-195	38-22	150-170	75-85
70	180-210	38-22	150-170	80-90
90	210-250	40-24	160-180	85-95
100	240-280	40-24	160-180	85-95
110	270-320	42-26	170-180	90-100

CYCLE TIME CHART

NOTE

To calculate total cycle time, add harvest time to freeze time listed in charts.

Ambient Temp. °F	Freeze Time			Harvest Time
	Water Temp.			
	50°F	70°F	90°F	
Water-Cooled				
70	8.5-10.5	10.0-12.5	12.5-14.0	1.25-2.25
80	9.0-10.5	10.5-12.5	12.5-14.5	
90	9.0-10.5	10.5-12.5	12.5-14.5	
100	9.5-11.0	11.0-13.0	13.0-15.5	
Air-Cooled				
70	8.5-10.0	10.0-11.5	10.5-12.5	1.25-2.25
80	9.0-10.5	10.5-12.0	11.5-13.5	
90	10.5-12.0	11.5-13.5	12.5-14.5	
100	13.0-14.5	14.0-16.5	15.0-17.5	

Remote Machines

Condenser Ambient Temp. °F	Freeze Time			Harvest Time
	Water Temp.			
	50°F	70°F	90°F	
-20 to 70	8.0-10.0	9.5-11.5	10.5-12.5	1.25-2.25
90	9.0-10.5	10.5-12.5	12.5-14.5	
100	10.5-12.5	12.5-14.5	13.5-16.0	
110	12.5-14.0	14.0-16.5	15.5-18.0	

Record Pressure of Freeze and Harvest Cycles

Freeze Cycle	Discharge	Suction
1. One minute to freeze 2. Middle of freeze 3. End of freeze		
Harvest Cycle		
1. Start of harvest 2. Middle of harvest 3. End of harvest		

Step 5A — Analyze Discharge Pressure

Using the Operational Pressure Chart, page 55, determine if the discharge pressure is correct for the ambient temperature the ice machine is located in.

A. If discharge pressure is within normal range, proceed to Step 5B to analyze suction pressure.

B. If discharge pressure is not within normal range, refer to the appropriate chart below.

C. Record findings on Refrigeration Diagnostic Chart, page 62.

DISCHARGE PRESSURE HIGH

Eliminate possible problems in the order listed on chart and follow appropriate corrective measures.

Possible Problem	Actual Finding	Corrective Measure
1. Excessive load conditions (air/water temperatures).		Refer to Installation Instructions.
2. Dirty condenser.		Clean.
3. Water regulating valve (water-cooled condenser): a. Too small supply water line. b. Out of adjustment. c. Defective regulating valve.		Replace with proper size line. Replace.
4. Fan motor/fan cycling switch defective.		Diagnose control, page 38.
5. Restriction on high side lines.		Repair, see Evacuation/Charging Procedures, page 69.
6. Headmaster Control Valve defective (remote machines).		Refer to Headmaster Control Valve Diagnostics, page 63.
7. Improper refrigerant charge.		Refer to Evacuation/Charging Procedures, page 69.
8. Noncondensables in system.		Refer to Evacuation/Charging Procedures, page 69.

DISCHARGE PRESSURE LOW

Eliminate possible problems in the order listed on chart and follow appropriate corrective measures.

Possible Problem	Actual Finding	Corrective Measure
1. Load conditions low (air/water temperatures).		Relocate ice machine to location within guidelines (refer to Installation Instructions).
2. Water regulating valve (water-cooled condensers): a. Out of adjustment. b. Leaking water during harvest cycle. c. Defective.		Readjust/replace if necessary. Replace.
3. Fan motor/fan cycling switch defective.		Diagnose control, page 38.
4. Headmaster Control Valve defective (remote machines).		Refer to Headmaster Control Valve Diagnostics, page 63.
5. Low refrigerant charge.		Continue through Six-Step Procedures.

Step 5B — Analyze Suction Pressure

NOTE

Discharge pressures must be analyzed before suction pressure.

To analyze suction pressure you must compare the Operational Pressure Chart, page 55, to the Cycle Time Chart, page 55. The suction pressure gradually drops as ice forms throughout the freeze cycle.

Example: 600 Series air-cooled:
 air temperature 90°F
 water temperature 70°F

From Cycle Time Chart, page 55:
 freeze time — 11.5 to 13.5 minutes
 harvest time — 1.25 to 2.25 minutes
 total cycle time — 12.75 to 15.7 minutes

From Operational Pressure Chart, page 55:
 suction pressure:
 start of freeze — 44 psi
 end of freeze — 26 psi

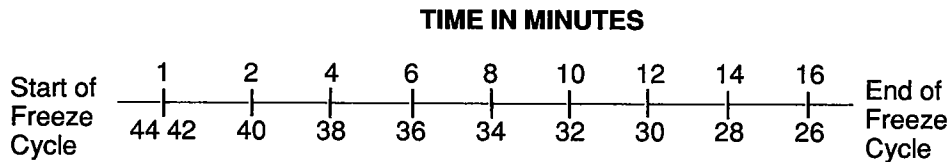

SUCTION PRESSURE

NOTE

Pressures are approximate and may vary slightly.

By comparing the two charts you can determine if suction pressure is properly pulling down.

- A. **Normal suction pressure:** proceed through Six-Step Procedure. (Example: 33 psi after 9 minutes into the freeze cycle is normal at 90°F air and 70°F water.)
- B. **Low suction pressure:** Refer to Suction Pressure Low chart, page 58. (Example: 12 psi after 3 minutes into the freeze cycle is considered low.)
- C. **High suction pressure:** Refer to Suction Pressure High chart below. (Example: 38 psi after 12 minutes into the freeze cycle is considered high.)

SUCTION PRESSURE HIGH

Eliminate the possible problems in the order listed on chart and follow appropriate corrective measure.

Possible Problem	Actual Findings	Corrective Measure
1. High discharge pressure affecting low side.		See Discharge Pressure High, page 56.
2. Hot gas valve stuck open.		Replace valve, page 58.
3. TXV flooding.		Continue through Six-Step Procedure.
4. Inefficient compressor (do not perform pumpdown test).		Continue through Six-Step Procedure.
5. Harvest pressure regulating solenoid valve leaking.		Replace valve.

SUCTION PRESSURE LOW

Eliminate the possible problems in the order listed on chart and follow appropriate corrective measure.

Possible Problem	Actual Findings	Corrective Measure
1. Low load conditions.		Relocate ice machine to location within guidelines.
2. No water flow over evaporator.		See Electrical Sequence of Operation, page 21.
3. Tubing separating from back-side of evaporator.		Replace evaporator.
4. Plugged drier/restriction in liquid line.		Repair — refer to Evacuation/Charging Procedures, page 69.
5. TXV starving.		Continue through Six-Step Procedure.

Step 5C — Hot Gas Valve Check

POSSIBLE PROBLEMS:

1. Improper valve.
A hot gas valve requires a specific orifice size which meters the proper amount of hot gas flow into the evaporator during the harvest cycle. Replace defective hot gas valves with original Manitowoc replacement (O.E.M.) parts only. Refer to your Parts Manual for proper valve application.

2. Stuck in harvest cycle: Check for voltage at coil.

IF YES: Refer to Electrical Sequence of Operation, page 21.

IF NO: Normally a hot gas valve can be repaired without changing the entire valve. Rebuild or replace the hot gas valve as required. Refer to Refrigeration Solenoid Valve Replacement, page 66.

3. Leaking during freeze cycle.
 - a. Symptoms of leaking hot gas valve:
 - 1) Ice production loss will be normal.
 - 2) Ice fill on evaporator will be normal.
 - 3) Suction pressure at the end of the freeze cycle will be slightly high. (This 1 to 4 psi increase can be difficult to detect.)
 - b. Check procedures.
 - 1) Feel **hot gas valve inlet**, Figure 55, page 59 after 5 minutes into freeze cycle.



CAUTION
HOT GAS VALVE INLET COULD BE HOT ENOUGH TO BURN YOUR HAND. TOUCH IT BRIEFLY.

- 2) Determine if the inlet is hot or close to compressor discharge line temperature.

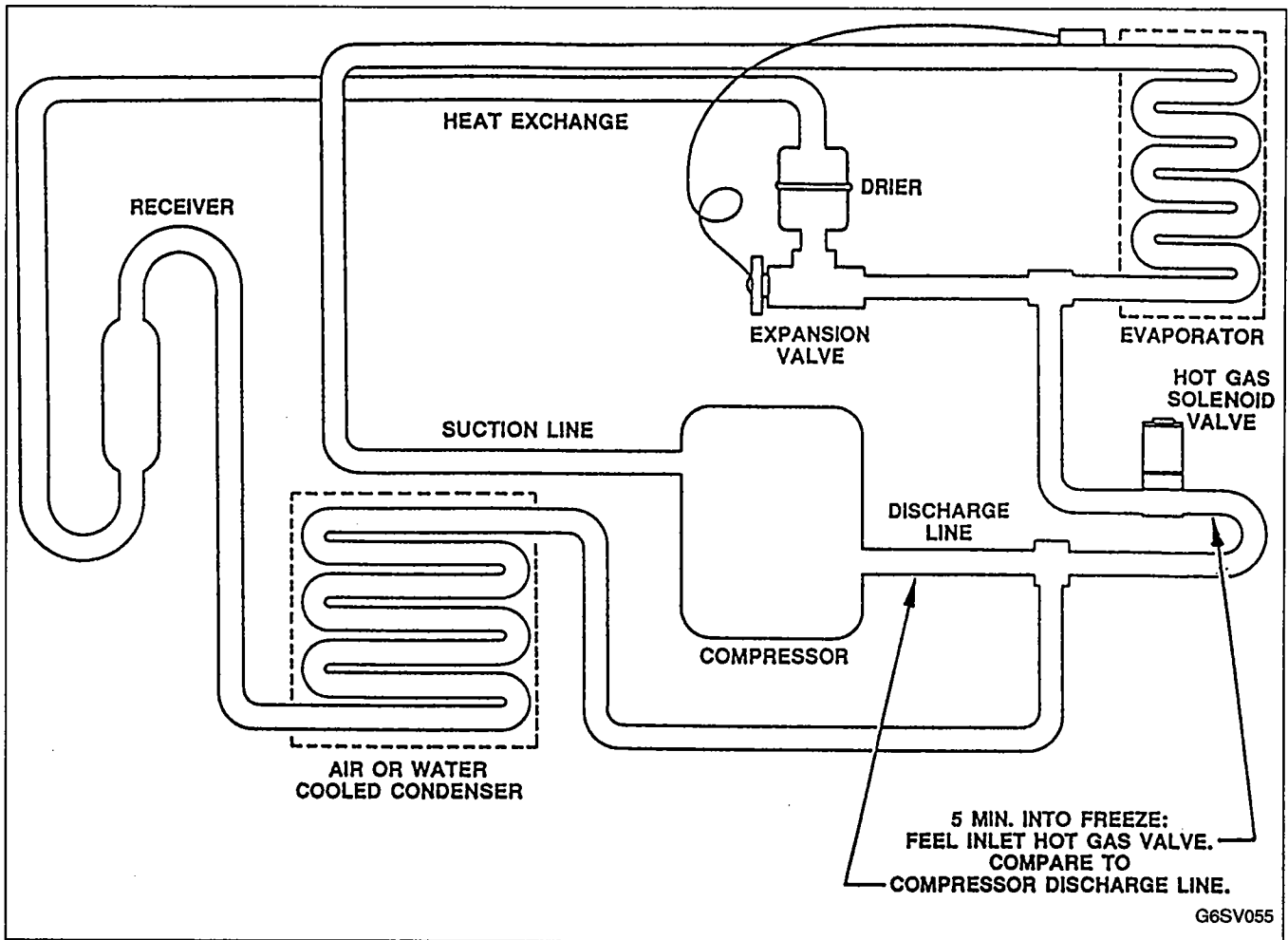

FIGURE 55. HOT GAS VALVE INLET FEEL CHECK

- 3) A **good hot gas** valve inlet line will be hot to touch during the harvest cycle and be cool enough to touch after approximately 5 minutes into the freeze cycle. With a **leaking hot gas valve**, the inlet will approach the discharge line temperature (hot to touch) during the freeze cycle.

Record your findings on the Refrigeration Component Diagnostic Chart, page 62.

Hot Gas Valve Inlet Feel Check Findings: (circle one)
 Compressor discharge temperature — Hot or Cool
 Hot gas solenoid **inlet** temperature — Hot or Cool

Step 5D — Thermal Expansion Valve (TXV) Checks

POSSIBLE PROBLEMS:

1. Improper valve.
 An improper valve will not achieve a uniform ice fill on the evaporator or proper ice production under all load conditions. Manitowoc O.E.M. expansion valves use special bulb gas charges, port sizes and stroke lengths to achieve this. Refer to the Parts Manual for proper valve usage.
2. TXV not installed properly.
 Refer to TXV Installation Procedures, page 65.
3. TXV starving or flooding.
 - a. Symptoms of a starving valve:
 - 1) Low ice production (may not make ice).
 - 2) Ice fill pattern — thin on top of evaporator and thick on bottom of evaporator.
 - 3) Suction pressure — lower than normal during freeze cycle.

- b. Symptoms of a flooding valve:
 - 1) Low ice production (may not make ice).
 - 2) Ice fill pattern — thick on top of evaporator and thin on bottom of evaporator.
 - 3) Suction pressure — higher than normal during freeze cycle.
- c. TXV operational check, Figure 56.

NOTE

This temperature check is used in conjunction with all information gathered during the entire Six-Step Procedure. **COMPLETE ALL 6 STEPS BEFORE CHANGING A TXV.**

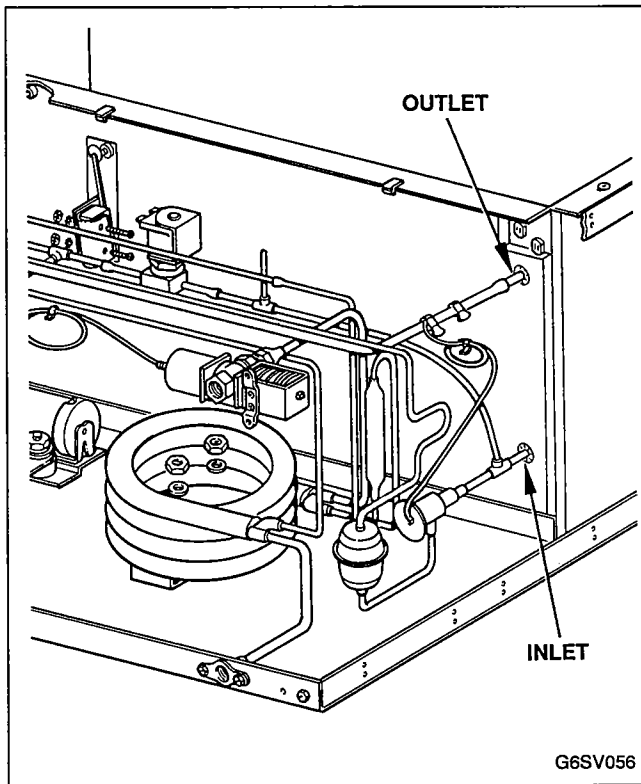

FIGURE 56. TXV OPERATIONAL CHECK

NOTE

TXV bulb must be insulated properly before performing test.

- 1) Measure the inlet and outlet temperatures of evaporator copper lines after at least 5 minutes into the freeze cycle.
- 2) A properly operating valve will maintain the inlet and outlet temperatures of the evaporator within approximately 5°F of each other.

- 3) An evaporator inlet temperature more than 5°F colder than the outlet indicates a starving TXV.
- 4) An evaporator inlet temperature more than 5°F warmer than the outlet indicates a flooding TXV.

Record your findings on the Refrigeration Component Chart, page 62.

Evaporator Temperature Findings:

Inlet of evaporator temperature _____
 Outlet of evaporator temperature _____

Step 5E — Compressor

1. Suction valves (inefficient compressor).
 An inefficient compressor can be hard to detect. Components or problems that are not directly related to the compressor can simulate a faulty compressor. To diagnose a faulty compressor, systematically check other components and rule them out one by one, following the entire Six-Step Procedure.

Symptoms of an inefficient compressor:

- a. Reduced ice production will be noticeable at lower ambient conditions and become more pronounced as ambient temperatures increase.
- b. Ice fill pattern — normal at lower ambients, although in extreme high ambient cases, there may be little or no ice formation.
- c. Suction pressures at the end of freeze cycle will be slightly high and become more pronounced as ambient temperature increases.
- d. There may be intermittent flooding by the TXV.

NOTE

An inefficient compressor may “pump down” and hold; therefore this type of test must not be used as a determining factor for replacing compressors.

2. Discharge valves.
 - a. The compressor shell will become hot and compressor may cycle on overload.
 - b. Suction pressure will be high.
 - c. Discharge pressure will be lower than normal.
 - d. Check procedure for discharge valves:
 - 1) Ensure compressor is running.
 - 2) Turn ice machine off.
 - 3) Immediately feel suction line — it will turn hot if the discharge valve is leaking or broken.

STEP 6 — FINAL ANALYSIS

Thoroughly following the first 5 steps has eliminated all nonrefrigerant problems. The Refrigeration Component Chart will verify what is causing the problem.

Fill out the chart using the following procedures:

1. Based on the symptoms found while performing Steps 1 through 5, fill in the Actual Findings column.
2. Each time the actual finding is the same as the characteristic listed to the right of a step number, put a check in the appropriate box. (Example: the actual finding is "thin ice on top of evaporator.") The box under starving TXV is the only box checked across the ice fill pattern section.
3. Add the number of boxes checked (under) each component failure and put the total in the bottom column. Refer to the component column with the most boxes checked and follow the appropriate procedures as listed in "a" through "d" below.
 - a. Hot Gas Valve Leaking column: Normally a leaking hot gas valve can be repaired without changing the entire valve. Rebuild or replace the hot gas valve as required. Refer to Refrigeration Solenoid Valve Replacement, page 66.
 - b. TXV Starving column: Verify the ice machine is not low on charge before replacing the TXV. Use the following guidelines:

NOTE

A starving TXV will normally only affect the freeze cycle pressures. A low refrigerant charge will affect both freeze and harvest cycle pressures.

- 1) Add charge in 2 to 4 oz. increments to see if the problem is corrected.
 - 2) If problem is not corrected by adding charge, change the TXV and drier. (Refer to Evacuating/Recharging, page 69.)
 - 3) If problem is corrected by adding charge, find the refrigerant leak, change the drier, evacuate and recharge, page 69. (System must operate with proper charge — do not leave run without changing drier, evacuating, and recharging.)
- c. TXV Flooding column: Step 5A "Analyze Discharge Pressure" has already verified the ice machine is not overcharged causing same symptoms as a flooding TXV. Replace the TXV and drier, evacuate, and recharge, page 69.
 - d. Inefficient Compressor column: Replace the compressor (and start components) and drier, evacuate, and recharge, page 69.

NOTE

To receive warranty credit on compressor, old start components must be returned with faulty compressor.

ICE MACHINE REFRIGERATION COMPONENT DIAGNOSTIC CHART

This chart is used with a detailed outline of each of the Six Steps listed.
Failure to follow the details of each step in order will result in a misdiagnosis.

STEPS	HOT GAS VALVE LEAKING (not wide open)	TXV STARVING	TXV FLOODING	INEFFICIENT COMPRESSOR	ACTUAL FINDINGS
1. Visual Inspection	Visual inspection includes checking for proper installation, location, dirty condensers, etc., and talking to the ice machine user to identify the perceived problem(s). (Refer to Step 1, page 52.)				
2. Ice Production	Normal ice production.	Low production – may not make ice.	Low production – may not make ice.	Minimal to low production.	
3. Ice Fill Pattern	Ice fill will be normal.	Ice fill will be thick on the bottom portion of the evaporator and thin on the top or no ice.	Ice fill will be thin on the bottom portion of the evaporator and thick on the top or no ice.	Ice fill will be normal.	
4. Water System	Water related problems can simulate a refrigeration component malfunction. Water related problems must be eliminated before proceeding to Step 5, page 55. Refer to Step 4, page 54, for complete water system analysis.				
5. Refrigeration System					
5A. Discharge Pressure	Discharge pressure must be normal before proceeding to Step 5B.				
5B. Freeze Cycle Suction Pressures	1 to 4 psi high at end of freeze cycle.	Lower than normal throughout freeze cycle. Usually may stabilize at one pressure.	Higher than normal throughout freeze cycle. Usually may stabilize at one pressure.	Slightly higher throughout freeze cycle. Pressures normally do pull down although take a long time.	
5C. Hot Gas Valve Inlet Feel Check	The inlet of hot gas valve is hot and approaches temperature of discharge line.			The inlet of hot gas valve is cooler than discharge line.	
5D. TXV Operational Check	Evaporator inlet and outlet temperatures within 5°F of each other.	Evaporator inlet and outlet temperatures not within 5°F; evaporator inlet temperature is colder than outlet temperature.	Evaporator inlet and outlet temperatures not within 5°F; evaporator inlet temperature is warmer than outlet temperature.	Evaporator inlet and outlet temperatures within 5°F of each other.	
Miscellaneous					
6. Final Analysis (number of boxes checked)	A.	B.	C.	D.	

HEADMASTER CONTROL VALVE (Remote Machines)

Description

Manitowoc remote systems require special Headmaster Control Valves manufactured to Manitowoc specifications. Refer to Remote Freeze Cycle Sequence of Operation, page 31.

Operation

The R-502 Headmaster Control Valve has a non-adjustable setting of 185 psi (± 10). At ambient temperatures of 70°F and above refrigerant flows through the valve from the condenser to the receiver inlet. At temperatures below 70°F the Headmaster pressure control dome's nitrogen charge closes the condenser port. The bypass port from the compressor discharge line opens. In this mode the valve maintains minimum compressor head pressure by building up liquid in the condenser. Discharge gas is bypassed directly to the receiver.

Diagnosing Headmaster Valve

Diagnosing problems in the Headmaster Control Valve requires that the system be properly charged.

Low Head Pressure

1. Add refrigerant in 2-pound increments. Do not exceed 6 pounds of additional refrigerant.
2. To assure proper operation in all ambient temperatures the system must be evacuated and the drier recharged. Refer to page 69.

Replacement

Replace the Headmaster Control Valve *only* with "original" Manitowoc (O.E.M.) replacement parts.

HEADMASTER CONTROL VALVE FAILURE CHART

Possible Problem	Probable Cause	Corrective Measure
Valve not operating properly.	Non-approved valve.	Install O.E.M. Headmaster Control Valve.
Discharge pressure extremely high and liquid line receiver feels hot.	Valve stuck in bypass.	Replace valve.
Discharge pressure below setting (185 psi ± 10 psi) and liquid line receiver extremely cold.	Valve not bypassing.	Replace valve.

HOW TO USE MANIFOLD GAUGES

Manifold gauges must be installed and removed properly to ensure no refrigerant contamination or loss occurs.

INSTALLING MANIFOLD GAUGES

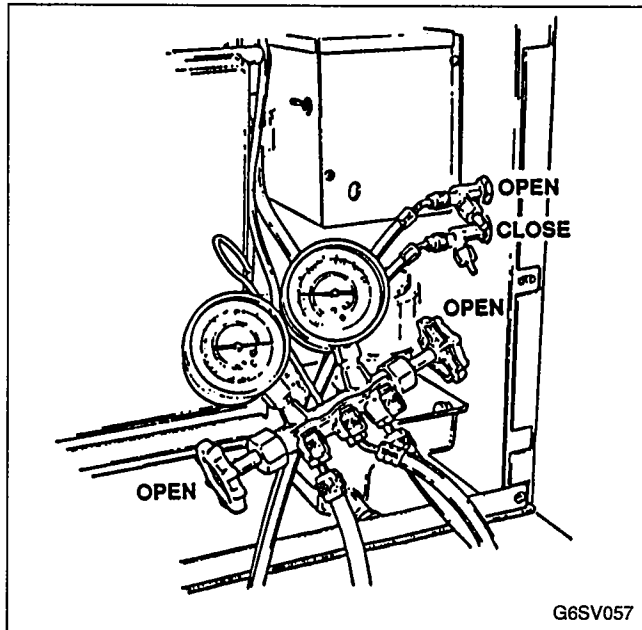

FIGURE 57. INSTALLING MANIFOLD GAUGES

1. Connect high side line to high side service valve at ice machine. See Figure 57.
2. Start low side line onto low side service valve at ice machine. Do not tighten.
3. Open both high and low side valves on manifold gauges. Be sure middle charging port is capped.
4. Backseat (open) high side service valve on ice machine. Allow a *small amount* of refrigerant to bleed from valve.

IMPORTANT

Tighten low side line as refrigerant bleeds through. This purges contaminants and noncondensables from manifold and hoses.

READING OPERATIONAL PRESSURES

1. Close both high and low side valves on manifold gauge set.

2. Backseat (open) both high and low side service valves at the ice machine.
3. With machine operating, read high and low side pressures on gauges.

REMOVAL OF MANIFOLD GAUGES

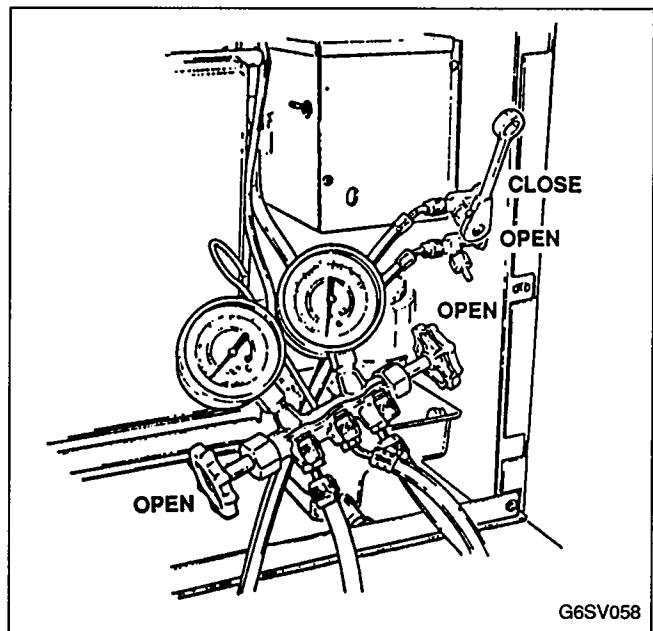

FIGURE 58. REMOVAL OF MANIFOLD GAUGES

1. Run ice machine in freeze cycle.
2. Close high side service valve at ice machine.
3. Backseat (open) low side service valve at ice machine.
4. Open both high and low side valves on manifold gauge set. Refrigerant in lines will now be pulled into the low side of system. Allow pressures to equalize with ice machine still in freeze cycle.
5. Frontseat (close) low side service valve at ice machine.
6. Remove hoses from ice machine and install caps.

NOTE

Removing manifold properly will ensure you do not alter charge and will eliminate releasing C.F.C.'s into atmosphere.

TXV INSTALLATION

Correct expansion valve installation is essential for proper operation. Some key points to remember when installing a valve include:

SOLDERING IN VALVE

Wrap the TXV with a wet rag. This will prevent damage to the valve from overheating.

BULB LOCATION

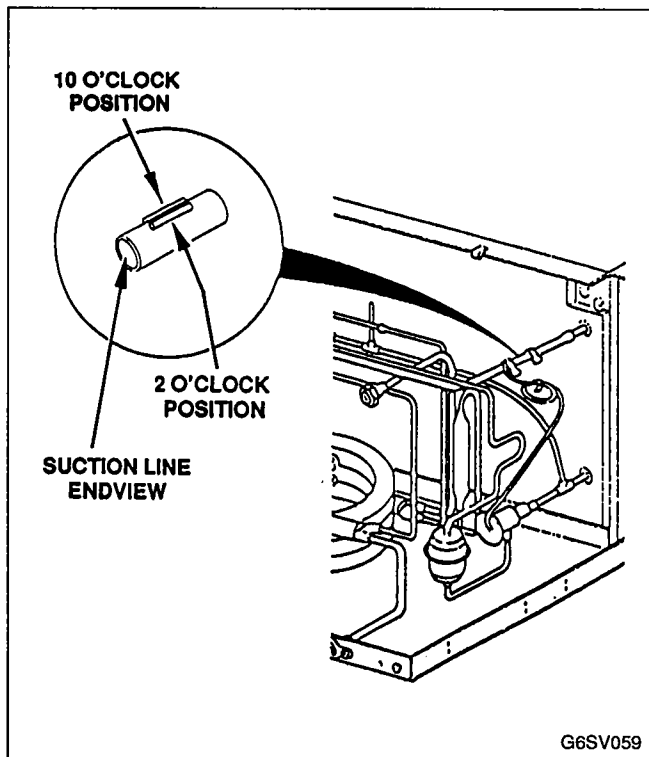

FIGURE 59. TXV BULB LOCATION

Bulb must be clamped to a smooth, straight, clean copper tube, not to a weld joint. Mount the bulb at the 10:00 or 2:00 o'clock position (Figure 59).

BULB CLAMP LOCATION

All Manitowoc expansion valve bulbs are to be mounted with two stainless steel screw clamps (Figure 59). Both clamps must be used. Clamps must be flush with each end of the bulb. Do not put both clamps in the middle of the bulb, as this can cause the bulb to bow or warp.

BULB CLAMP TIGHTNESS

Bulbs must be tight for good thermal contact. A properly tightened bulb will not move around the suction line when twisted by hand. Properly tightened clamps may slightly deform the bulb. This is normal and will not hurt valve operation.

BULB INSTALLATION CHECK

To check if the bulb has good thermal contact, hold a flashlight under the bulb and look for light between the bulb and the suction line. If no light is seen, the contact is good. If light can be seen between the bulb and the suction line, the contact is poor, and the valve may misfeed. The bulb must be retightened and/or moved slightly and rechecked.

BULB INSULATION

The bulb insulation must be at least 3/8 inch thick. If thinner insulation is used, apply additional layers.

NOTE

Insulate the valve body to prevent sweating.

ALCO REFRIGERATION SOLENOID VALVES (200 RB SERIES) REPLACEMENTS

The internal parts of Alco solenoid valves (200 RB Series) are replaceable without changeout of the brass body. Rebuild kit, Manitowoc part No. 24-0460-3, is available for these Alco solenoid valves. The rebuild kit includes the plunger, spring, O-ring, and piston assembly. A solenoid valve which has a damaged seat or is stuck open or closed can, in most cases, be repaired by installing the rebuild kit. See Figure 60.

Use the following guidelines for warranty replacements.

1. Install rebuild kit when the enclosing tube and brass valve body are **not defective**.
2. Replace the entire solenoid assembly when the brass valve body is found defective or if the internal surface of the enclosing tube does not permit smooth plunger and piston operation.
3. Replace coil only when a coil malfunctions (open, shorts, etc.).

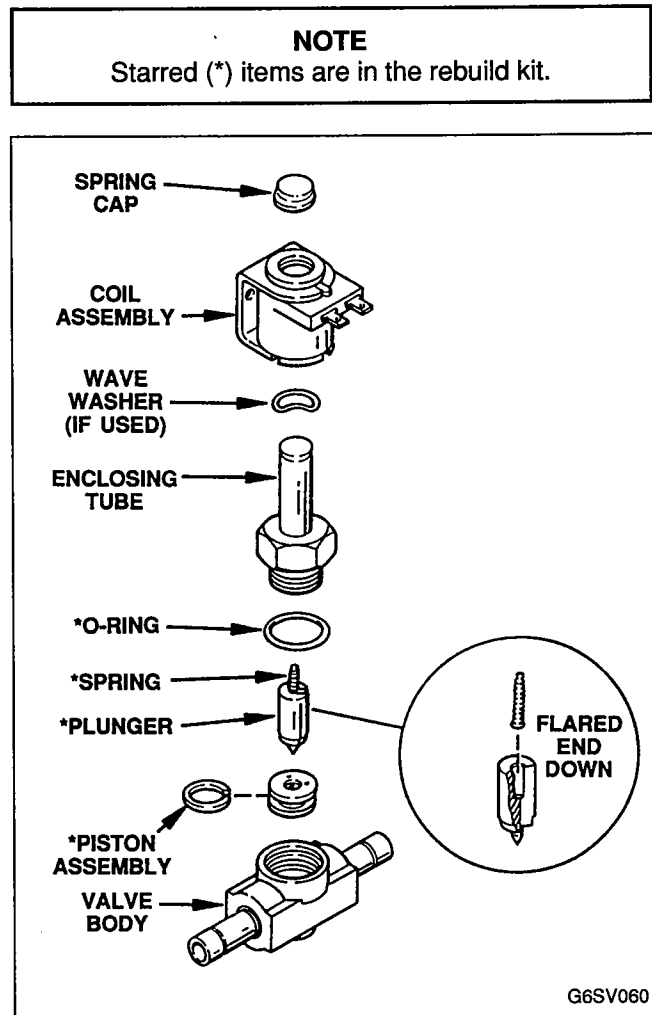

FIGURE 60. REFRIGERATION SOLENOID VALVE

LEAK CHECKING CONDENSER AND WATER REGULATING VALVE

IMPORTANT

Both the condenser and water regulating valve must be leak checked.

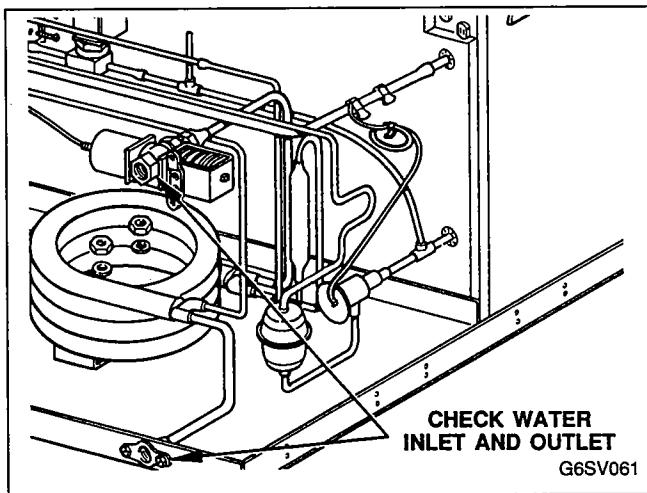

FIGURE 61. CONDENSER LEAK CHECK POINTS

LEAK CHECKING CONDENSER

1. Set ICE/OFF/WATER PUMP switch at OFF.
2. Turn off incoming condenser water supply.
3. Disconnect incoming condenser water inlet and outlet lines.
4. Disconnect water regulating valve from condenser.
5. Blow water out of condenser with compressed air.

NOTE

Water in the condenser may cause an electronic leak detector to give a false signal.

6. Ensure refrigeration system is pressurized.
7. Check condenser water inlet and outlet with electronic leak detector. If a leak is detected, replace condenser. See Figure 61.

NOTE

If no leak is detected with the ice machine off, set the ICE/OFF/WATER PUMP switch at ICE. Allow discharge pressure to reach 250 psi, then set ICE/OFF/WATER PUMP switch at OFF and recheck for leaks.

LEAK CHECKING WATER REGULATING VALVE

NOTE

Water regulating valve must be disconnected from the condenser. Completely dry water valve inlet and outlet to eliminate false readings from the leak detector.

1. Ensure refrigeration system is pressurized.
2. Leak check where cap tube meets the bellows housing. See Figure 62.
3. Leak check around bellows seal.
4. Open valve by prying open at spring with screwdriver, leak check inlet and outlet with leak detector. If leak is detected, replace valve.
5. If no leak is detected, refer to NOTE under step 7 of Leak Checking the Condenser and recheck valve for leaks.

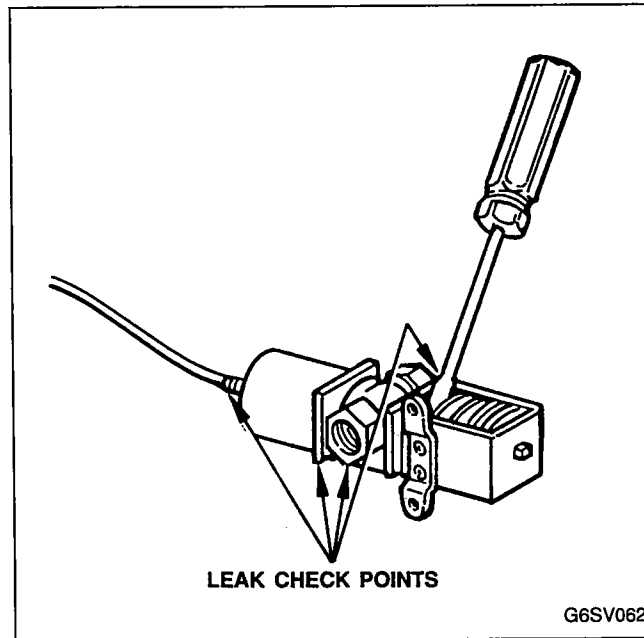

FIGURE 62. WATER REGULATING VALVE LEAK CHECK POINTS

REMOVAL FROM SERVICE/WINTERIZATION

You must take special precautions if the ice machine is to be removed from service for extended periods or exposed to ambient temperatures of 32°F or below.



CAUTION

IF WATER IS ALLOWED TO REMAIN IN THE MACHINE IN FREEZING AMBIENT TEMPERATURES, IT WILL FREEZE, RESULTING IN SEVERE DAMAGE TO COMPONENTS. A FAILURE OF THIS NATURE IS NOT COVERED BY WARRANTY.

Self-Contained Air-Cooled Machines

1. Disconnect electric power at circuit breaker or electric service switch.
2. Turn off water going to ice machine.
3. Remove drain plug from water trough.
4. Disconnect drain line and incoming ice making water line at rear of ice machine.
5. Blow compressed air in both incoming water opening and drain opening in rear of machine until water is no longer coming out of float valve and drain.
6. Ensure that no water is trapped in any of the machine's water lines, drain lines, distribution tubes, etc.
7. If machine is outside, cover machine to prevent exposure to the elements.

Water-Cooled Machines

1. Perform all procedures listed under Air-Cooled Machines.
2. Disconnect incoming water line and drain line from water-cooled condenser.
3. Pry open water regulating valve by inserting large standard screwdriver between bottom spring coils of valve. Pry spring upward to open valve, Figure 63.

4. Hold valve open and blow compressed air through condenser until no water remains.
5. Ensure no water is trapped in the water lines, drain lines and distribution tube.
6. If ice machine is outside, cover machine to prevent exposure to elements.

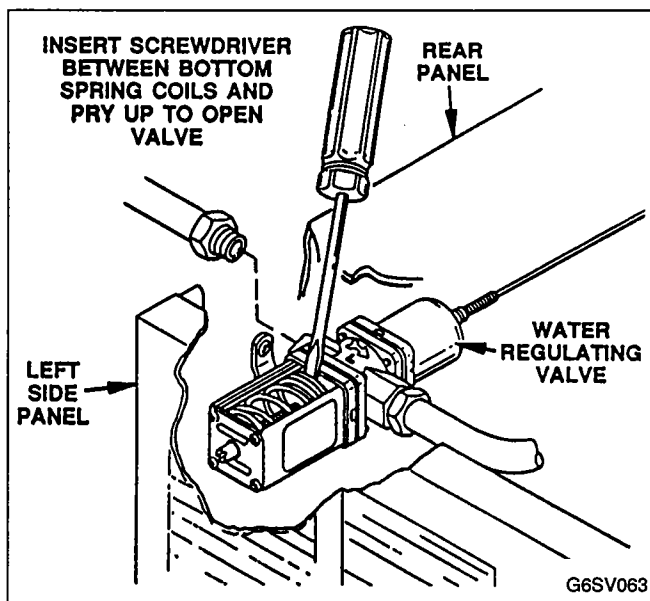

FIGURE 63. MANUALLY OPENING WATER REGULATING VALVE

Remote Machines

1. Frontseat receiver service valve, then pump down ice machine. (Hang a tag on toggle switch as a reminder to open receiver service valve on start-up.)
2. Perform all procedures listed under "Self-Contained Air-Cooled Machines."

NOTE

Before putting a remote machine back into operation after winterization, backseat the receiver service valve.

EVACUATION AND RECHARGING

REMOVAL OF REFRIGERANT

Do not purge the refrigerant to the atmosphere. Recapture refrigerant using recovery equipment by following specific manufacturer's recommendations.

IMPORTANT

Manitowoc Ice, Inc. assumes no responsibility for the use of recycled refrigerant. Damage resulting from the use of recycled refrigerant is solely the responsibility of the servicing company.

EVACUATION AND RECHARGING OF SELF-CONTAINED SYSTEMS

Before proceeding, determine severity of contamination and clean-up procedures, page 73.

1. Replace liquid line drier.

IMPORTANT

TO PREVENT VOIDING WARRANTY, USE ONLY MANITOWOC (O.E.M.) LIQUID LINE FILTER DRIERS.

2. Fully open service valves.
3. Evacuation of the ice machine requires connections at two points as follows:
 - a. Suction service valve.
 - b. Discharge service valve.Connect manifold gauges, dial-a-charge (or weigh-in method), and vacuum pump to ice machine, Figure 64.

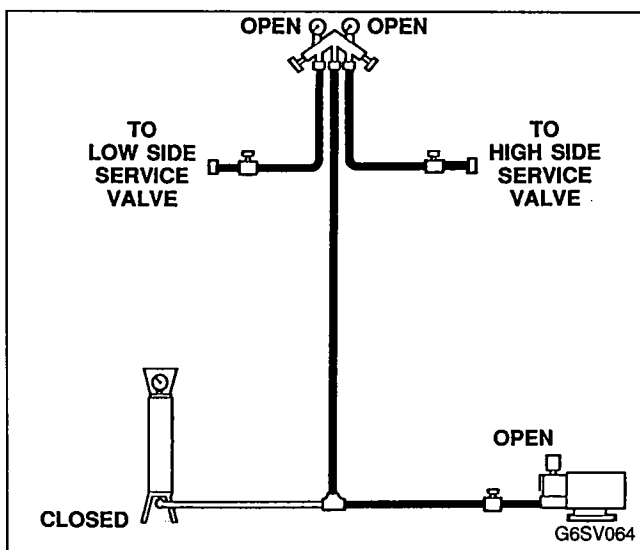

FIGURE 64. EVACUATION OF SELF-CONTAINED SYSTEMS

NOTE

Install a two-stage vacuum pump to manifold gauges. A single stage pump will slow the evacuation process.

Procedures for Self-Contained Evacuation

IMPORTANT

Refer to refrigeration system Contamination Clean-Up Procedures, page 74, for proper clean-up procedures if system contamination is suspected or detected. Improper or insufficient clean-up will lead to repeat failures.

1. Place toggle switch in OFF position.
2. Open (backseat) high and low side ice machine service valves. Open vacuum pump valve. Open high and low side on manifold gauges. Refer to Figure 64.
3. Start vacuum pump. Pull system down to 250 microns. Allow pump to run for 1/2 hour after reaching 250 microns.

NOTE

Turn off vacuum pump after 1/2 hour and ensure pressures do not rise.

4. Refer to Recharging Procedures and recharge ice machine.

Procedures for Self-Contained Recharging

IMPORTANT

Charge must be weighed or measured into ice machine to assure proper operation under all load conditions. Do not charge by sight glass, pressure, etc.

1. Ensure toggle switch is in OFF position. Refer to Figure 65 and recharge system.

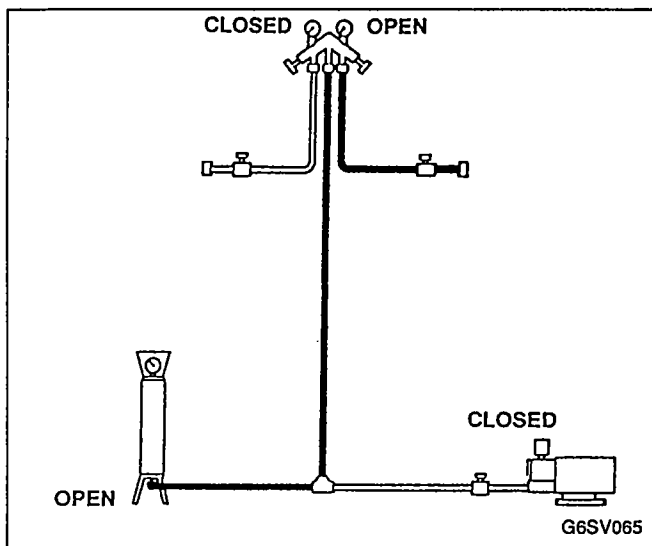

FIGURE 65. RECHARGING OF SELF-CONTAINED SYSTEMS

2. Close vacuum pump valve, low side service valve, and low side valve on manifold gauge.

3. Open high side manifold gauge valve, backseat high side service valve.
4. Open charging cylinder and add measured nameplate charge through discharge service valve.
5. Allow system to "settle" for 2 or 3 minutes after charging.
6. Place ice machine toggle switch in ICE position, close high side on manifold gauge set, and add remaining vapor charge through suction service valve (if necessary).
7. Ensure all vapor in charging hoses is drawn into the ice machine before disconnecting manifold gauges.

NOTE

Recheck for leaks with a Halide or electronic leak detector after recharging ice machine.

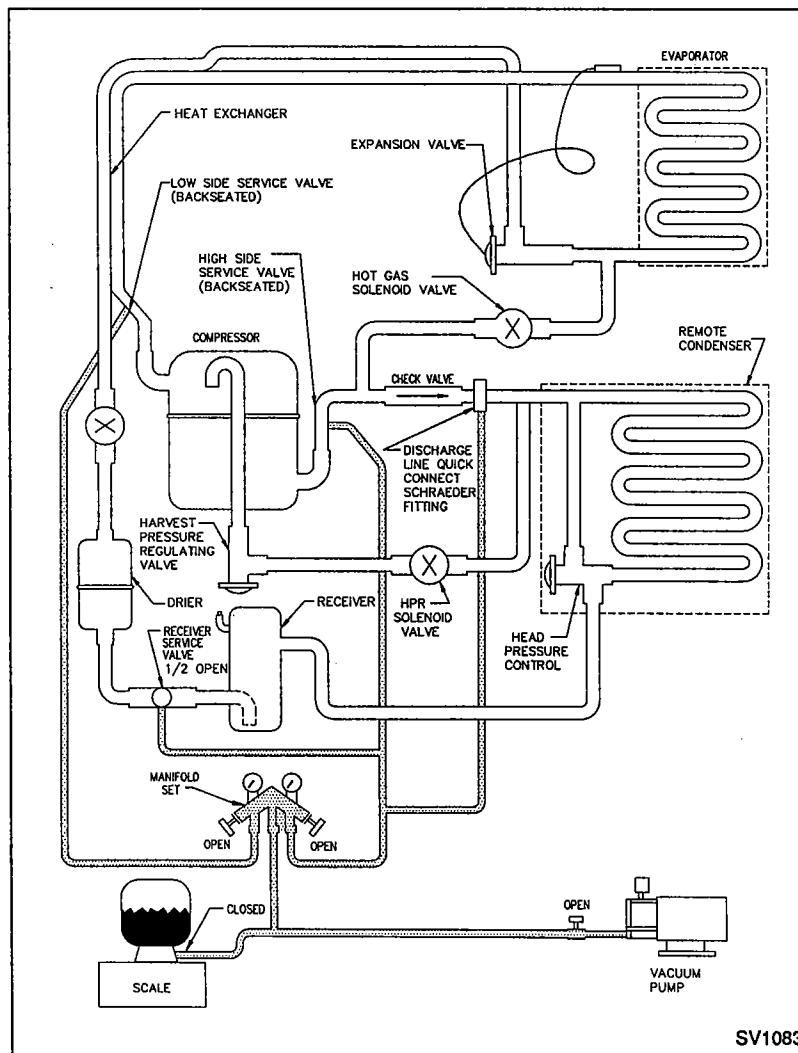

FIGURE 66. EVACUATION OF REMOTE SYSTEMS

EVACUATION AND RECHARGING OF REMOTE SYSTEMS

Before proceeding, determine severity of contamination and cleanup procedures, page 73.

1. Evacuation of remote systems requires connection at four points for complete evacuation as follows. Refer to Figure 66.
 - a. Suction side of compressor through suction service valve.
 - b. Discharge side of compressor through discharge service valve.
 - c. Receiver outlet service valve. (Evacuates area between head pressure control valve in condenser and pump-down solenoid.)
 - d. Access (Schraeder) valve on discharge line quick connect fitting on outside of compressor/evaporator compartment. This connection is necessary to evacuate the condenser. Without this connection, the magnetic check valve would close upon the pressure drop produced by evacuation prohibiting complete condenser evacuation.

NOTE

Manitowoc recommends using an access valve core removal and installation tool on the discharge line quick connect fitting. The tool permits removal of the access valve core for faster evacuation and charging without removing the manifold gauge hose.

NOTE

Install a two-stage vacuum pump to manifold gauges. A single-stage pump will slow the evacuation process.

Procedures for Remote System Evacuation

IMPORTANT

Refer to refrigeration system Contamination Clean-Up Procedures, page 74, for proper clean-up procedures if system contamination is suspected or detected. Improper or insufficient clean-up will lead to repeat failures.

1. Place toggle switch in OFF position.
2. Install manifold gauges, scale and two-stage vacuum pump as shown on Figure 66.

3. Open (backseat) high and low side ice machine service valves, position receiver service valve 1/2 open, and open high and low side on manifold gauge set.

NOTE

If access valve core removal and installation tool is used, remove discharge line quick-connect valve core at this time.

4. Start vacuum pump, pull system down to 250 microns. Allow pump to run for 1 hour after reaching 250 microns. Turn off vacuum pump, ensure pressures do not rise (standing vacuum leak-check).
5. Charge the ice machine per the following charging procedures.

Procedures for Remote System Recharging

NOTE

Refer to Figure 67 to connect cylinder or scale and vacuum pump to recharge the system.

1. Ensure toggle switch is in the OFF POSITION.
2. Close vacuum pump valve, frontseat (close) low side and high side service valves, close low side valve on manifold gauge set.
3. Add measured nameplate charge from charging scale through high side of manifold gauge set into system high side (receiver outlet valve and discharge lines quick-connect fitting).
4. If high side does not take entire charge, close high side on manifold gauge set, backseat (open) low side service valve, and receiver outlet service valve. Start ice machine and add remaining charge through low side in vapor form until the machine is fully charged.
5. Ensure all vapor in charging hoses is drawn into the machine before disconnecting manifold gauges.

NOTE

Backseat (open) receiver outlet service valve after charging is complete and before operating the ice machine. If access valve core removal and installation tool is used on the discharge line quick-connect fitting, reinstall Schraeder valve core before disconnecting access tool and hose.

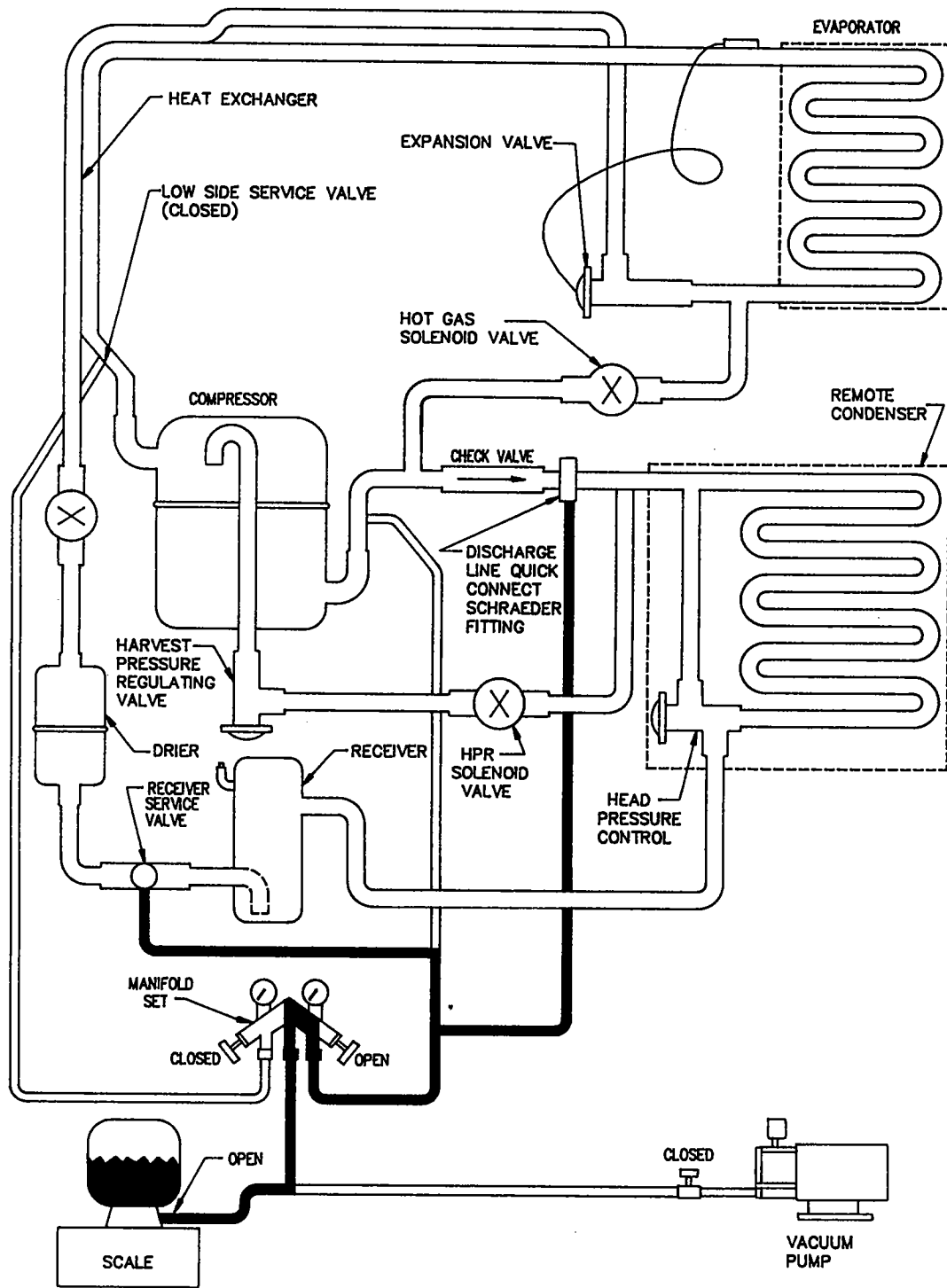

SV1082

FIGURE 67. RECHARGING OF REMOTE SYSTEMS

SEVERE SYSTEM CONTAMINATION

GENERAL

It is important to read and understand the following text regarding severe system contamination. The purpose is to describe the basic requirements for restoring contaminated systems to reliable service.

IMPORTANT

Manitowoc Ice, Inc. assumes no responsibility for the use of recycled refrigerant. Damage resulting from the use of contaminated recycled refrigerant is the sole responsibility of the servicing company.

DETERMINING SEVERITY OF CONTAMINATION AND CLEAN-UP PROCEDURES

System contamination is generally caused by the introduction of either moisture or residue from compressor burnout into the refrigeration system.

Inspection of the refrigerant is usually the first indication of contaminants in the system. If obvious moisture or an acrid odor indicating burnout is present in the refrigerant, steps must be taken to determine the severity of contamination as well as the required clean up-procedure.

If visible moisture or an acrid odor is detected, or if contamination *is suspected*, the use of a Total Test Kit from Totaline or similar diagnostic tool is recommended. These devices read refrigerant, therefore eliminating the need for an initial oil sample for testing.

If a refrigerant test kit indicates harmful levels of contamination, or if the kit is not available, then inspect the compressor oil as follows:

1. Remove refrigerant charge from ice machine.
2. Remove compressor from the system.
3. Check odor and condition (appearance) of the oil.
4. Inspect open suction and discharge lines at compressor for burnout deposits.
5. Perform an acid oil test if contamination signs are not evident per the above procedure to ensure no harmful contamination is present

The following chart lists findings and matches them with required clean-up procedure. Use this chart for determining type of clean-up required.

CONTAMINATION/CLEAN-UP CHART

Symptoms/Findings	Required Clean-Up Procedure
No symptoms or suspicion of contamination	Normal evacuation and recharging procedures, page 69.
Moisture/Air Contamination (one or more of the following conditions will exist) — Refrigeration system open to atmosphere for prolonged periods — Refrigeration test kit and/or acid oil test shows contamination — Leak in water-cooled condenser — Oil appears muddy, or visible moisture in oil	Mild contamination clean-up procedures, page 74.
Mild Compressor Burnout — Oil appears clean with acrid odor and/or — Refrigeration test kit or acid oil test shows harmful acid content — No burnout deposits in open compressor lines	Mild contamination clean-up procedures, page 74.
Severe Compressor Burnout — Oil discolored and acidic with acrid odor, burnout deposits in compressor, discharge and suction lines and other components	Severe contamination clean-up procedures, page 74.

MILD SYSTEM CONTAMINATION CLEAN-UP PROCEDURES

1. Replace failed components if applicable. If compressor checks good, change oil in compressor.
2. Replace liquid line drier.
3. Follow normal evacuation procedure, page 69, except replace the evacuation step with the following:

NOTE

If contamination is from moisture, the use of heat lamps or heaters is recommended during evacuation. Place heat lamps at the compressor, condenser, and at the evaporator prior to evacuation. (Ensure heat lamps are not positioned too close to plastic components such as evaporator extrusions, water trough, etc., as they could melt, warp, etc.)

IMPORTANT

Dry nitrogen is recommended for this procedure to prevent C.F.C. release into the atmosphere.

- a. Pull vacuum to 1000 microns. Break vacuum with dry nitrogen and sweep system. Pressurize to a minimum of 5 psi.
 - b. Pull vacuum to 500 microns. Break vacuum with dry nitrogen and sweep system. Pressurize to a minimum of 5 psi.
 - c. Change vacuum pump oil. Pull system down to 250 microns. When 250 microns have been achieved, allow vacuum pump to run for 1/2 hour on self-contained models, 1 hour for remotes. A standing vacuum test may be performed at this time as a preliminary means of leak checking; however, the use of an electronic leak detector after the system has been charged is recommended.
4. Charge system with proper refrigerant to nameplate charge.
 5. Operate ice machine.

SEVERE SYSTEM CONTAMINATION CLEAN-UP PROCEDURES

1. Remove refrigerant charge.
2. Remove compressor.
3. Disassemble hot gas solenoid valve. If burnout deposits are found inside valve, install rebuild kit and replace TXV. If contaminants are found replace harvest pressure limiter control.
4. Check discharge and suction lines at compressor for burnout deposits. Wipe out as necessary.

5. Sweep through open system with dry nitrogen.

NOTE

Refrigerant sweeps are not recommended, as they release C.F.C.'s into the atmosphere.

6. Installation Procedures:
 - a. Install new compressor and start components.
 - b. Install an adequately sized suction line filter-drier with acid/moisture removal capability and inlet/outlet access valves. Place the filter-drier as close to the compressor as practical.
 - c. Replace liquid line filter-drier.
7. Follow normal evacuation procedures, page 69, except replace the evacuation step with the following:

IMPORTANT

Dry nitrogen is recommended for this procedure to prevent C.F.C. release into the atmosphere.

- a. Pull vacuum to 1000 microns. Break vacuum with dry nitrogen and sweep system. Pressurize to a minimum of 5 psi.
 - b. Change vacuum pump oil. Pull vacuum to 500 microns. Break vacuum with dry nitrogen and sweep system. Pressurize to a minimum of 5 psi.
 - c. Change vacuum pump oil. Pull system down to 250 microns. When 250 microns have been achieved, allow vacuum pump to run for 1/2 hour for self-contained models, 1 hour for remotes. A standing vacuum test may be performed at this time as a preliminary means of leak checking; however, the use of an electronic leak detector after the system has been charged is recommended.
8. Charge system with proper refrigerant to nameplate charge.
 9. Operate ice machine.
 - a. Check pressure drop across the suction line filter-drier after 1 hour running time. If pressure drop is not excessive (up to 1 psi differential) the filter-drier should be adequate for complete clean-up. Proceed to step 10.
 - b. If pressure drop is greater than 1 psi after 1 hour run time, change the suction line filter-drier and liquid line drier. Repeat until ice machine will run 1 hour without pressure drop.
 10. Remove suction line filter-drier after 48-72 hours run time. Change liquid line drier and follow normal evacuation procedures, page 69.



MANITOWOC ICE, INC.

2110 South 26th Street P.O. Box 1720

Manitowoc, WI 54221-1720

Phone: (920) 682-0161

Fax: (920) 683-7585

Web Site: www.manitowocice.com

© 1999 Manitowoc Ice, Inc.
Litho in U.S.A.