

Q Model QuietQube® Ice Machines

Technician's Handbook

This manual is updated as new information and models are released. Visit our website for the latest manual.
www.manitowocice.com

America's #1 Selling Ice Machine

Part Number 80-0099-9 6/11

Safety Notices

As you work on Manitowoc equipment, be sure to pay close attention to the safety notices in this handbook. Disregarding the notices may lead to serious injury and/or damage to the equipment.

Throughout this handbook, you will see the following types of safety notices:



Warning

Text in a Warning box alerts you to a potential personal injury situation. Be sure to read the Warning statement before proceeding, and work carefully.



Caution

Text in a Caution box alerts you to a situation in which you could damage the equipment. Be sure to read the Caution statement before proceeding, and work carefully.

Procedural Notices

As you work on Manitowoc equipment, be sure to read the procedural notices in this handbook. These notices supply helpful information which may assist you as you work.

Throughout this handbook, you will see the following types of procedural notices:

Important

Text in an Important box provides you with information that may help you perform a procedure more efficiently. Disregarding this information will not cause damage or injury, but it may slow you down as you work.

NOTE: Text set off as a Note provides you with simple, but useful, extra information about the procedure you are performing.

Read These Before Proceeding:

Caution

Proper installation, care and maintenance are essential for maximum performance and trouble-free operation of your Manitowoc equipment. If you encounter problems not covered by this handbook, do not proceed, contact Manitowoc Foodservice Group. We will be happy to provide assistance.

Important

Routine adjustments and maintenance procedures outlined in this handbook are not covered by the warranty.

Warning

PERSONAL INJURY POTENTIAL

Do not operate equipment that has been misused, abused, neglected, damaged, or altered/modified from that of original manufactured specifications.

We reserve the right to make product improvements at any time. Specifications and design are subject to change without notice.

Table of Contents

Model Numbers

Model/Serial Number Location	2
------------------------------------	---

Ice Machine Warranty Information

Owner Warranty Registration Card	3
Warranty Coverage	4
General.....	4
Parts	4
Labor	4
Exclusions	4
Authorized Warranty Service.....	5
Service Calls.....	5

Installation

Location of Ice Machine	6
Ice Machine Head Section	
Clearance Requirements	6
Q0600C/Q0800C/Q1000C	6
SU1000/SerVend UC-300:	6
Stacking Two Ice Machines on a Single Storage Bin	7
Ice Deflector	7
Location of CVD® Condensing Unit	8
Condensing Unit Clearance Requirements	8
Ice Machine Head Section Water Supply and Drains.....	9
Potable Water Supply.....	9
Potable Water Inlet Lines	9
Drain Connections.....	10
Water cooled condenser water supply and drains	11
Condenser Water Supply	11
Water Cooled Condenser Lines	11
Condensing Unit Drain Connections	12

Electrical Requirements.....	13
QuietQube® Ice Machines and CVD® Condensing Units	13
3 Phase Scroll Compressor Rotation.....	13
Refrigeration System Installation.....	15
Usage With Non-Manitowoc Condensing Units	15
Factory Equipment Refrigerant Amounts.....	16
Refrigeration Line Set Installation.....	17
3 Phase Scroll Compressor Rotation CVD2075 Only	29
Condensing Unit Heat of Rejection	29

Operational Checks

General.....	30
Water Level	30
Q0600C/Q0800C/Q1000C/QDUAL	30
Q1400C/SU1000C.....	31
Ice Thickness Check	32
Harvest Sequence Water Purge.....	33

Interior Cleaning and Sanitizing

AlphaSanO	36
Cleaning Procedure.....	37
Sanitizing Procedure	39
Automatic Cleaning System (AuCS®) Accessory	41
Removal of Parts for Cleaning or Sanitizing...	43

Removal from Service/Winterization

General.....	63
CVD1476 Water Cooled Condensing Unit	64
AuCS® Accessory	64

Component Identification

Ice Machine Head Section	65
Q0600C/Q0800C/Q1000C	65
SU1000C/SerVend UC-300 Dispenser	67
Q1400C	68
QDUAL	69
CVD® Condensing Unit	70
CVD0675/CVD0875/CVD1075/CVD1475	70
CVD1476	71
CVD1875/CVD2075	72

Ice Making Sequence of Operation

Q0600C/Q0800C/Q1000C/SU1000C	73
Initial Start-Up or Start-Up After Automatic Shut-Off	73
Freeze Sequence	74
Harvest Sequence	75
Automatic Shut-Off	76
Q1400C	79
Initial Start-Up or Start-Up After Automatic Shut- Off	79
Freeze Sequence	79
Harvest Sequence	80
QDUAL	84
Initial Start-Up or Start-Up After Automatic Shut- Off	84
Freeze Sequence	85
Harvest Sequence	86

Electrical System

Component Specifications and Diagnostics Control Board.....	91
Harvest/Safety Limit Light.....	91
Freeze Time Lock-In Feature	91
Maximum Freeze Time.....	91
Safety Limits	91
Three-Minute Delay	92
Inputs.....	92
Control Board Relays.....	92
Main Fuse.....	95
Function	95
Specifications.....	95
Check Procedure	95
Bin Switch.....	96
Function	96
Specifications.....	96
Check Procedure	97
Ohm Test.....	97
Water Curtain Removal Notes	98
ICE/OFF/CLEAN Toggle Switch.....	99
Function	99
Specifications.....	99
Check Procedure	99
Ice Thickness Probe (Harvest Initiation).....	100
How the Probe Works.....	100
Ice Thickness Check.....	100
Ice Thickness Probe Diagnostics.....	101
Diagnosing Ice Thickness Control Circuitry ..	102
Water Level Control Circuitry.....	105
Diagnosing an Ice Machine Head Section that Will Not Run	112
Diagnosing a Condensing Unit that Will Not Run	113
Compressor Electrical Diagnostics.....	114
Diagnosing Start Components.....	116
Electrical Diagrams.....	117
Ice Machine Head Section.....	117
Condensing Unit	121

Refrigeration System

Refrigeration System Diagnostics	123
General.....	123
Refrigeration System Operation	123
Ice Machine will Not Harvest Diagnostics	127
Harvest Cycle Diagnostic List.....	127
Ice Production Check	128
Installation/Visual Inspection Checklist.....	129
Water System Checklist	130
Ice Formation Pattern	131
Evaporator Tubing Routing.....	131
Safety Limits	134
Analyzing Suction Pressure.....	142
Cool Vapor Valve	146
Normal Operation	146
Cool Vapor Valve Analysis	147
Freeze Cycle Suction Line Temperature Analysis	148
Refrigeration Component Diagnostic Charts.....	150
General.....	150
Procedure	150
Final Analysis	150
Refrigeration Component Diagnostic Charts.....	152
Single Expansion Valve – Q0600C/0800C/ Q1000C/SU1000C.....	152
Dual Expansion Valve – Q1400C/QDUAL....	157
Pressure Control Specifications and Diagnostics.....	160
Headmaster Control Valve	160
Water Regulating Valve.....	170
Fan Cycle Control.....	171
High Pressure Cutout (HPCO) Control.....	172
Low Pressure Cutout (LPCO) Control	173
QuietQube® Tubing Schematics.....	174
Q0600C/Q0800C/Q1000C	174
Q1400C/QDUALC	175

Cycle Times/24-Hour Ice Production/Refrigerant Pressure Charts

Q0600C/CVD675 Series Remote Air Cooled....	177
Q0800C/CVD875 Series Remote Air Cooled....	178
Q1000C/CVD1075 Series Remote Air Cooled..	179
SU1000C/SerVend UC-300 Dispenser/CVD1075 Remote Air Cooled	180
Q1400C/CVD1475 Series Remote Air Cooled..	181
Q1400C/CVD1476 Remote water Cooled.....	182
QDUAL/CVD1875 Remote Air Cooled	183
QDUAL/CVD2075 Remote air Cooled.....	184

Refrigerant Recovery/Evacuation

System Contamination Cleanup	188
General	188
Determining Severity of Contamination	188
Cleanup Procedure.....	190
Replacing Pressure Controls Without Removing Refrigerant Charge	193
Filter-Driers.....	195
Liquid Line Filter-Drier	195
Suction Line Filter	196
Total System Refrigerant Charge	197
Refrigerant Oil	198
Refrigerant Definitions	199
Refrigerant Reuse Policy.....	200

Model Numbers

This manual covers the following models:

Ice Machine Head Section	CVD® Condensing Unit*
QR0670C QD0672C QY0674C	CVD0675
QR0870C QD0872C QY0874C	CVD0875
QR1070C QD1072C QY1074C	CVD1075 CVD1285
SU1024YC/SerVend UC-300 Dispenser	CVD1075
QR1470C QD1472C QY1474C	CVD1375 CVD1475 CVD1476
QRDUALC QDDUALC QYDUALC	CVD1875 CVD2075
*For 3 phase electrical option: add the number "3" to end of model number (CVD10753).	

Important

The ice machine sequence of operation for QuietQube® Ice Machines will differ. Verify the correct sequence of operation is being followed for the model you are working on.

 **Warning**

Manitowoc QuietQube® Ice Machines require the ice storage bin to incorporate an ice deflector, when installing with non-Manitowoc ice storage systems or Manitowoc F style bins.

Prior to using a non-Manitowoc ice storage system with Manitowoc ice machines, contact the manufacturer to assure their ice deflector is compatible with Manitowoc ice machines.

MODEL/SERIAL NUMBER LOCATION

These numbers are required when requesting information from your local Manitowoc Distributor, service representative, or Manitowoc Ice, Inc. The model and serial number are listed on the OWNER WARRANTY REGISTRATION CARD. They are also listed on the MODEL/SERIAL NUMBER DECAL affixed to the ice machine.

Ice Machine Warranty Information

OWNER WARRANTY REGISTRATION CARD

Warranty coverage begins the day the ice machine is installed.

Important

Complete and mail the OWNER WARRANTY REGISTRATION CARD as soon as possible to validate the installation date.

If the OWNER WARRANTY REGISTRATION CARD is not returned, Manitowoc will use the date of sale to the Manitowoc Distributor as the first day of warranty coverage for your new ice machine.

WARRANTY COVERAGE

General

The following Warranty outline is provided for your convenience. For a detailed explanation, read the warranty bond shipped with each product.

Contact your local Manitowoc representative or Manitowoc Ice, Inc. if you need further warranty information.

Important

This product is intended exclusively for commercial application. No warranty is extended for personal, family, or household purposes.

Parts

1. Manitowoc warrants the ice machine against defects in materials and workmanship, under normal use and service for three (3) years from the date of original installation.
2. The evaporator and compressor are covered by an additional two (2) year (five years total) warranty beginning on the date of the original installation.

Labor

1. Labor required to repair or replace defective components is covered for three (3) years from the date of original installation.
2. The evaporator is covered by an additional two (2) year (five years total) labor warranty beginning on the date of the original installation.

Exclusions

The following items are not included in the ice machine's warranty coverage:

1. Normal maintenance, adjustments and cleaning as outlined in this manual.
2. Repairs due to unauthorized modifications to the ice machine or use of non-standard parts without prior written approval from Manitowoc Ice, Inc.

3. Damage caused by improper installation of the ice machine, electrical supply, water supply or drainage, or damage caused by floods, storms, or other acts of God.
4. Premium labor rates due to holidays, overtime, etc.; travel time; flat rate service call charges; mileage and miscellaneous tools and material charges not listed on the payment schedule. Additional labor charges resulting from the inaccessibility of equipment are also excluded.
5. Parts or assemblies subjected to misuse, abuse, neglect or accidents.
6. Damage or problems caused by installation, cleaning and/or maintenance procedures inconsistent with the technical instructions provided in this manual.

This product is intended exclusively for commercial application. No warranty is extended for personal, family, or household purposes.

Authorized Warranty Service

To comply with the provisions of the warranty, a refrigeration service company qualified and authorized by your Manitowoc Distributor, or a Contracted Service Representative must perform the warranty repair.

NOTE: If the dealer you purchased the ice machine from is not authorized to perform warranty service, contact your Manitowoc Distributor or Manitowoc Ice, Inc. for the name of the nearest authorized service representative.

Service Calls

Normal maintenance, adjustments and cleaning as outlined in this manual are not covered by the warranty. If you have followed the procedures listed in this manual, and the ice machine still does not perform properly, call your Local Distributor or the Service Department at Manitowoc Ice, Inc.

Installation

LOCATION OF ICE MACHINE

The location selected for the ice machine head section must meet the following criteria. If any of these criteria are not met, select another location.

- The location must be free of airborne and other contaminants.
- The air temperature must be at least 35°F (1.6°C), but must not exceed 110°F (43.4°C).
- The location must not be near heat-generating equipment or in direct sunlight.

ICE MACHINE HEAD SECTION CLEARANCE REQUIREMENTS

Q0600C/Q0800C/Q1000C

Top/Sides

There is no minimum clearance required, although 5 in. (127 mm) is recommended for efficient operation and servicing only.

Back

1 in. (25 mm) required when routing electrical inlet, water inlet and refrigeration tubing out of the top of the unit.

5 in. (127 mm) required when routing all connections out the back.

SU1000/SerVend UC-300:

Top

40 in. (100 mm) required for cleaning procedures and servicing.

Back

12 in. (30.5cm) required for cleaning procedures and servicing.

STACKING TWO ICE MACHINES ON A SINGLE STORAGE BIN

Q0600C/Q0800C/Q1000C Ice Machines:

A stacking kit is required for stacking two ice machines. Installation instructions are supplied with the stacking kit.

Q1400C/QDUAL Ice Machines:

Q1400C and QDUAL ice machines cannot be stacked. However two Q1400C/QDUAL ice machines can be placed side by side on a 60 in. Manitowoc F style bin.

ICE DEFLECTOR

QDUAL ice machines mounted on an ice dispenser do not require an ice deflector.

QDUAL ice machines mounted on an ice storage bin (Manitowoc or non-Manitowoc) require the use of an ice deflector. Refer to sales literature to determine the proper kit for your application. This kit is necessary to allow access to the shut-off valves during installation and will improve access during future service.

An ice deflector is required for all ice machines installed on a bin.

LOCATION OF CVD® CONDENSING UNIT

The location selected for the CVD® Condensing Unit must meet the following criteria. If any of these criteria are not met, select another location.

- The air temperature must be at least -20°F (-28.9°C), but must not exceed 130°F (54.4°C) -20°F (-28.9°C) to 120°F (54.4°C) QDUAL CVD1875/CVD2075).
- CVD1476 only - The air temperature must be at least 50°F (10°C) but must not exceed 110°F (43°C).
- The location must not allow exhaust fan heat and/or grease to enter the condenser.
- The location must not obstruct airflow through or around the condensing unit.

CONDENSING UNIT CLEARANCE REQUIREMENTS

Top/Sides

There is no minimum clearance required, although 6 in. (152 mm) is recommended for efficient operation and servicing only.

Front/Back

4 ft. (122 cm)

ICE MACHINE HEAD SECTION WATER SUPPLY AND DRAINS

Potable Water Supply

Local water conditions may require treatment of the water to inhibit scale formation, filter sediment, and remove chlorine odor and taste.

Important

If you are installing a Manitowoc water filter system, refer to the Installation Instructions supplied with the filter system for ice making water inlet connections.

Potable Water Inlet Lines

Follow these guidelines to install water inlet lines:

- Do not connect the ice machine to a hot water supply. Be sure all hot water restrictors installed for other equipment are working. (Check valves on sink faucets, dishwashers, etc.)
- If water pressure exceeds the maximum recommended pressure obtain a water pressure regulator from your Manitowoc Distributor.
 - Float Valve - 80 psi (551.5 kPa)
 - Water Inlet Valve - 90 psi (620.4 kPa)
- Install a water shut-off valve for ice making potable water.
- Insulate water inlet lines to prevent condensation.

Drain Connections

Follow these guidelines when installing drain lines to prevent drain water from flowing back into the ice machine and storage bin:

- Drain lines must have a 1.5 in. drop per 5 ft. of run (2.5 cm per meter), and must not create traps.
- The floor drain must be large enough to accommodate drainage from all drains.
- Run separate bin and ice machine drain lines. Insulate them to prevent condensation.
- Vent the bin and ice machine drain to the atmosphere.
- Drains must have a union or other suitable means of disconnection from the ice machine when servicing is required.
- The SU1024YC is designed for installation on a SerVend UC-300 dispenser only. Refer to the SerVend UC-300 Installation, Use and Care Manual for additional drain requirements.

WATER COOLED CONDENSER WATER SUPPLY AND DRAINS

Condenser Water Supply

Local water conditions may require treatment of the water to inhibit scale formation to filter sediment.

Water Cooled Condenser Lines

Follow these guidelines to install water lines:

- Contact your distributor if your water pressure is greater than 150 psi (1034kPA). A special order condensing unit is available that allows water pressure up to 350 psi (2413 kPA).
- Install a shutoff valve (inlet and outlet on cooling tower or closed loop circuits) to allow isolation of the water system.
- Water entering the condenser must not exceed 90°F (32.2°C).
- Water flow through the condenser must not exceed 5 gallons (19 liters) per minute.
- Allow for a pressure drop of 8 psi (55 kPA) between the condenser water inlet and outlet.
- Water exiting the condenser must not exceed 110°F (43.3°C).



Warning

Water pressure at the condenser cannot exceed 150 psig (1034kPA) with the standard water regulating valve. Contact your distributor if your water pressure is greater than 150 psig (1034 kPA). A special order condensing unit is available that allows water pressure up to 350 psig (2413 kPA).

Condensing Unit Drain Connections

The condensing unit drain is provided to remove any condensate produced by the suction accumulator. Condensate amounts will vary depending on temperature and humidity.

- The condensing unit must be level front to back and side to side to allow the condensate to drain.
- Drain lines must have 1.5-inch drop per 5 feet of run (2.5 cm per meter), and must not create traps.
- Drain termination must meet applicable codes.

ELECTRICAL REQUIREMENTS

QuietQube® Ice Machines and CVD® Condensing Units

Ice Machine Head Section			
	Voltage Phase Cycle	Max. Fuse/ Circuit Breaker	Total Amps
Q0600C	115/1/60	15 amp	1.1
Q0800C			
Q1000C	230/1/50	15 amp	0.6
SU1000C			
Q1400C			
QDUAL			

Important

The QuietQube® Ice Machine Head Section and CVD® Condensing Unit are wired independently from each other.

3 Phase Scroll Compressor Rotation

CVD2075 3 PHASE ONLY

A trained and qualified technician must verify compressor rotation at equipment startup or compressor warranty will be void. Incorrect rotation of a scroll compressor can be identified by:

- Noisy compressor operation
- Elevated suction pressure
- Low discharge pressure
- Compressor trips on overload protector

To change compressor rotation, reverse (exchange locations) any two incoming power supply leads.

CVD® Condensing Unit			
	Voltage Phase Cycle	Max. Fuse/ Circuit Breaker	Min. Circuit Amps
CVD0675	208-230/1/60	15 amp	9.6
	208-230/3/60	15 amp	7.3
	230/1/50	15 amp	9.0
CVD0875	208-230/1/60	20 amp	11.7
	208-230/3/60	15 amp	8.2
	230/1/50	20 amp	11.3
CVD1075	208-230/1/60	25 amp	15.6
	208-230/3/60	20 amp	10.6
	230/1/50	25 amp	13.8
CVD1475	208-230/1/60	35 amp	19.6
	208-230/3/60	25 amp	14.1
	230/1/50	35 amp	19.8
CVD1476	208-230/1/60	30 amp	15.3
	208-230/3/60	20 amp	10.8
CVD1875	208-230/1/60	40 amp	21.1
	208-230/3/60	30 amp	11.0
	230/1/50	40 amp	23.2
CVD2075	208-230/1/60	50 amp	27.1
	208-230/3/60	40 amp	19.9
	230/1/50	50 amp	29.9

 **Caution**

**Scroll Compressor Rotation
(CVD2075 3 Phase Only)**

Correct compressor rotation must be verified at start-up. Incorrect rotation will result in increased compressor noise and higher than normal suction pressure. To change rotation, reverse two lead wires on the incoming power supply. Compressor must be checked by a qualified technician or compressor warranty will be void.

REFRIGERATION SYSTEM INSTALLATION

QuietQube® Ice Machine	CVD® Condensing Unit	Line Set
Q1000C SU1000C/ UC-300 Q1400C	CVD1075 CVD1475 CVD1476	RC-20 RC-30 RC-50
Q0600C Q0800C	CVD0675 CVD0875	RC-21 RC-31 RC-51
QDUAL	CVD1875 CVD2075	RC-22 RC-32 RC-52

Line Set	Suction Line	Liquid Line	Insulation Thickness
RC 20/30/50	3/4 in. (19.1 mm)	1/2 in. (12.7 mm)	Suction Line 1/2" (13 mm)
RC 21/31/51	5/8 in. (15.9 mm)	3/8 in. (9.5 mm)	Liquid Line 1/4" (7 mm)
RC 22/32/52	7/8 in. (22.2 mm)	5/8 in. (15.9 mm)	Suction Line 3/4" (19 mm) Liquid Line 1/4" (7 mm)

Usage With Non-Manitowoc Condensing Units

Manitowoc CVD® Condensing Units are specifically designed for usage with a QuietQube® Ice Machine Head Section. Standard condensing units will not operate a QuietQube® Ice Machine Head Section.

Factory Equipment Refrigerant Amounts

ICE MACHINE HEAD SECTION

Q0600C/Q0800C/Q1000C/SU1000C/Q1400C

Each ice machine head section ships from the factory with an R-404A refrigerant charge appropriate for the entire system operation. The serial tag on the ice machine indicates the refrigerant charge. The refrigerant charge is sufficient to operate the ice machine in ambient temperatures between -20°F (-28.9°C) and 130°F (54.4°C), (CVD1476, 50°F to 110°F, 10°C to 43°C) with line set lengths of up to 100 ft. (30.5 m).

QDUAL

Each QDUAL ice machine head section ships from the factory with an R-404A refrigerant charge appropriate for installations with up to 50" of refrigerant tubing. The serial tag on the ice machine indicates the refrigerant charge. For line set runs longer than 50 ft., 1 lb. of additional refrigerant must be added for each 10 ft. of line set run. The receiver is designed to hold a charge sufficient to operate the ice machine in ambient temperatures between -20°F (-28.9°C) and 120°F (49°C), with line set lengths of up to 100 feet (15 m)

Caution

Never add more than nameplate charge to the refrigeration system for any application.

Caution

The 60-month compressor warranty (including the 36-month labor replacement warranty) will not apply if the Manitowoc Ice Machine and Manitowoc CVD® Condensing Unit are not installed according to specifications. This warranty also will not apply if the refrigeration system is modified with a condenser, heat reclaim device, or other parts or assemblies not manufactured by Manitowoc Ice, Inc.



Warning

Potential Personal Injury Situation

The ice machine head section contains the refrigerant charge. Installation and brazing of the line sets must be performed by a properly trained refrigeration technician aware of the **dangers of dealing with refrigerant** charged equipment.

Refrigeration Line Set Installation

Refrigeration line set installation consists of vertical and horizontal line set distances between the ice machine and the condensing unit. The following guidelines, drawings and calculation methods must be followed to assure proper oil return and CVD[®] Condensing Unit/ice Machine operation.

Step 1. Prior to installation of the ice machine and CVD[®] Condensing Unit be sure that the distance between them is within the line set routing guidelines outlined in this manual.

Step 2. Properly route refrigeration tubing between the Ice Machine Head Section and the CVD[®] Condensing Unit.

For a roof/wall penetration, cut a 3-in. (76.2 mm) circular hole in the wall or roof for routing of refrigeration tubing, as required. A qualified person must perform all roof penetrations.

A. LINE SET LENGTH



Caution

QuietQube[®] Ice Machines will not function with line sets greater than 100 ft. (30.5 m). Do not attempt to go beyond this distance and add refrigerant charge to compensate!

B. LINE SET RISE OR DROP

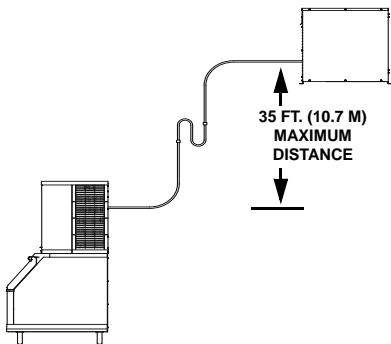

35 ft. (10.7 m) Rise: The maximum distance the CVD[®] Condensing Unit can be above the ice machine.

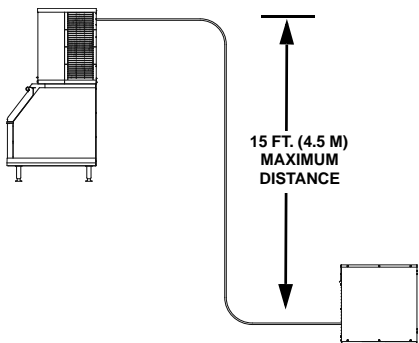

15 ft. (4.5 m) Drop: The maximum distance the CVD[®] Condensing Unit can be below the ice machine.

C. SUCTION LINE OIL TRAPS

Caution

Do not form unwanted traps in refrigeration lines.
Never coil excess refrigeration tubing.

0 to 20 ft. (0 to 6.1 m) Rise: The ice machine head section has one oil trap built in which allows for a maximum condenser rise of 20 ft. (6.1 m) without additional traps in the suction line.

21 to 35 ft. (6.4 to 10.7 m) Rise: The suction line requires an additional oil trap ("S" type) to be installed. Install the trap as close as possible to midpoint between the ice machine head section and CVD[®] Condensing Unit. S-Trap Kits are available from Manitowoc (refer to chart).

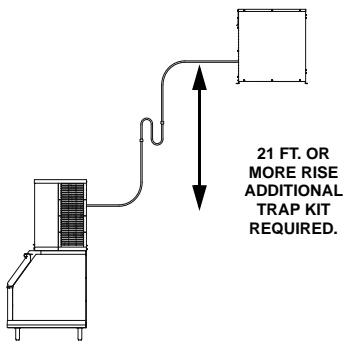

SV1751

Manitowoc S-Trap Kit

Model	S-Trap Kit #	Tubing Size
Q0600C Q0800C	K00172	5/8 in. (15.9 mm)
Q1000C SU1000C Q1400C	K00166	3/4 in. (19.1 mm)
QDUAL	K00164	7/8 in. (22.2 mm)

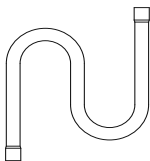

SV1760

SERVICE LOOP

A service loop in the line set permits easy access to the ice machine for cleaning and service.

- The supplied service loop is an installation requirement. Excess tubing must allow 180 degree rotation of the ice machine.
- A service loop is not considered an oil trap.
- The service loop is not included when calculating the length, rise or drop of the tubing run.
- Do not use hard rigid copper for the service loop.

Caution

If a line set has a rise followed by a drop, another rise cannot be made. Likewise, if a line set has a drop followed by a rise, another drop cannot be made.

Step 3. When the line set requires shortening or lengthening, do so before connecting the line set to the ice machine head section or the CVD® Condensing Unit.

 **Caution**

Do not form unwanted traps in refrigeration lines.
Never coil excess refrigeration tubing.

Step 4. To prevent oxidation of the copper, purge line set and condensing unit with dry nitrogen while brazing. .

 **Warning**

The ice machine head section contains refrigerant charge. The ice machine head section contains three (3) refrigeration valves that **must remain closed** until proper installation of the line sets is completed.

CONNECT THE LINE SET TO THE ICE MACHINE HEAD SECTION

The line set shut-off valves at the back of the ice machine must remain closed and be protected from heat during the brazing process. Wrap the valves in a wet rag or other type of heat sink prior to brazing. Cool braze joint with water immediately after brazing to prevent heat migration to the valve.

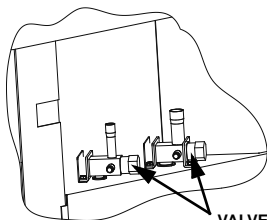

SV1757

**VALVES MUST REMAIN CLOSED
AND BE PROTECTED FROM
HEAT WHEN BRAZING
(WRAP WITH WET RAG).
Q0600C/Q0800C/Q1000C SHOWN**

CONNECT THE LINE SET TO THE CVD® CONDENSING UNIT

Warning

The condensing unit ships from the factory pressurized with a 50/50 mixture of nitrogen/helium. Bleed off pressure from both suction and liquid line access ports prior to cutting into refrigeration lines.

The compressor oil rapidly absorbs moisture. **Be prepared** to complete line set installation and start your evacuation process in order to minimize the time the compressor is exposed to the atmosphere. (Maximum amount of time the system can be exposed to the atmosphere is 15 minutes.)

The line set can be routed for entry through the front or left side of the condensing unit.

- Remove knockout for preferred location.
- Insert supplied plastic bushings in knockout holes to prevent tubing from contacting sheet metal.
- Use the supplied 90° elbows to route tubing.
- Cut the tubing ends of the suction and liquid lines and braze line sets to the condensing unit.

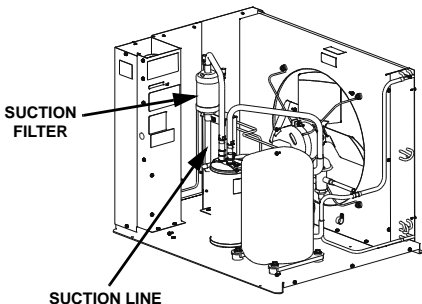

PT1284A

**MINIMIZE THE TIME THE REFRIGERATION
SYSTEM IS EXPOSED TO THE ATMOSPHERE
(15 MINUTES MAXIMUM).**

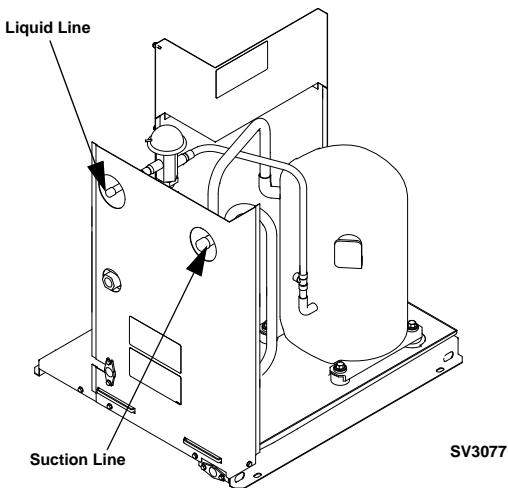

Step 5. Schrader valve core removal tools that allow for removal and installation of the valve cores without removing manifold gauge set hoses are recommended to decrease the evacuation time.

Leave the line set shut-off valves closed (front seated). Pressure test the line sets and CVD[®] Condensing Unit with 150 psig of dry nitrogen. Add nitrogen at the line set shut-off valves located at the back of the ice machine. Complete the pressure test, verify no leaks are present and remove the nitrogen from the system before connecting the vacuum pump. Connect a vacuum pump to both of the line set shut-off valves located at the back of the ice machine head section. Evacuate to 250 microns (or less). To completely evacuate the CVD[®] Condensing Unit, continue the evacuation for 30 minutes after reaching the 500-micron point.

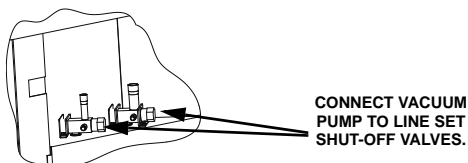

**ALTERNATE CONNECTIONS AT
CONDENSING UNIT SCHRADER VALVES**

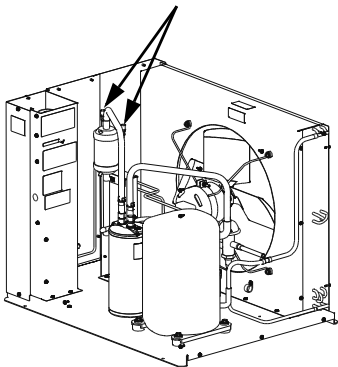

PT1284

If required, the line set and condensing unit can be evacuated from the schrader valves located in the CVD® Condensing Unit. Schrader valve core removal tools (that allow for putting the cores back in without removing vacuum pump hoses) must be used if evacuating from the condensing unit side.

Isolate the vacuum pump from the line set shut-off valves and/or condensing unit access ports prior to proceeding.

Step 6. The suction line, liquid line and receiver service valves are closed during shipment and installation.

Open the valves prior to starting the ice machine.

- A. Slowly backseat (open – turn counterclockwise) the suction line shut-off valve.
- B. Slowly backseat (open – turn counterclockwise) the liquid line shut-off valve.
- C. Slowly backseat (open-turn counterclockwise) the receiver service valve.

Q0600C/Q0800C/Q1000C

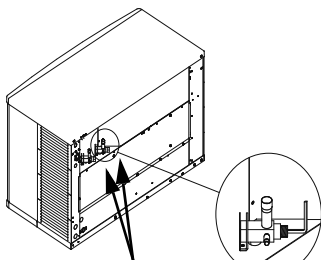

USE ALLEN WRENCH TO OPEN
(TURN COUNTERCLOCKWISE)
LIQUID AND SUCTION LINE
SHUT-OFF VALVES.

SV1762

Q1400C/QDUAL

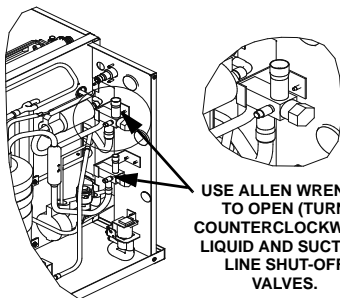

USE ALLEN WRENCH
TO OPEN (TURN
COUNTERCLOCKWISE)
LIQUID AND SUCTION
LINE SHUT-OFF
VALVES.

SV1769c

**SUCTION AND LIQUID LINE
SHUT-OFF VALVES**

Important

All refrigeration valve caps must be reinstalled to prevent future refrigeration leaks.

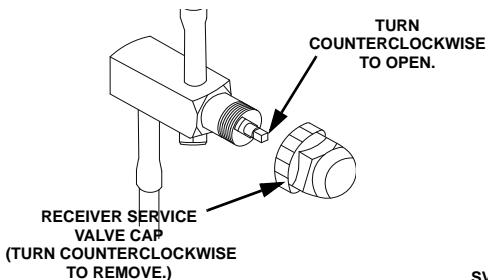

SV1756

RECEIVER SERVICE VALVE

Verify O-rings in schrader valve caps are intact and reinstall on shut-off valves to prevent refrigerant leakage. Replace shut-off valve access caps and torque to the following specifications.

Torque Values	
Stem	18-20 ft. lbs.
Caps	12-15 ft. lbs.
Schraeder Core	1.5-3 in. lbs.

Replace cap on receiver service valve and tighten. There is a liquid line solenoid valve at the outlet of the receiver; refrigerant will not flow to the condensing unit until the ice machine head section is started. Connect power to both the ice machine head section and the CVD[®] Condensing Unit. Place the ice machine toggle switch into the ICE position; this will allow refrigerant to enter the line set and condensing unit.

Step 7. Leak check the new line set connections at the ice machine head section, condensing unit and S-trap as well as all factory joints throughout the entire system. Disconnect power to the CVD[®] Condensing Unit. Place the ICE/OFF/CLEAN toggle switch in the ICE position. This allows the low side and high side

pressures to equalize. Place the ICE/OFF/CLEAN toggle switch in the OFF position. Connect power to the CVD® Condensing Unit and allow system to pump down.

Step 8. To prevent condensation, the entire suction line including the shut-off valve must be insulated. All insulation must be airtight and sealed at both ends.

The following insulation requirements prevent condensation at 90°F (32.2°C) ambient 90% Relative Humidity. If higher humidity is expected, increase insulation thickness.

The entire suction line set, including the suction service valve located on the back of the ice machine, requires a minimum of 3/4 in. (12.7 mm) wall thickness insulation.

The entire liquid line set requires a minimum of 1/4 in. (6.4 mm) wall thickness insulation.

Important

To prevent condensation, the entire suction line including the shut-off valve must be insulated. All insulation must be airtight and sealed at both ends.

This requires a minimum of 3/4 in. (12.7 mm) insulation wall thickness with conditions at or below 90% humidity and 90° ambient. When higher humidity will be experienced, insulation wall thickness will need to be increased.

SUCTION SHUT-OFF VALVE INSULATION

The preformed suction shut-off valve insulation is located in the plastic bag taped to the water curtain.

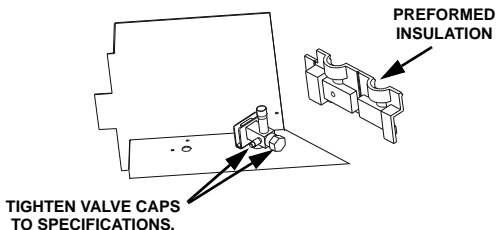

- A. Verify valve and schrader caps are tightened to specifications (see step 6).

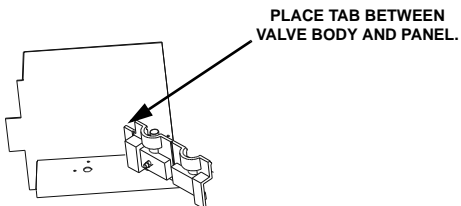

- B. Place insulation over schrader valve cap and left side of valve. Position the tab between the mounting bracket and rear panel.

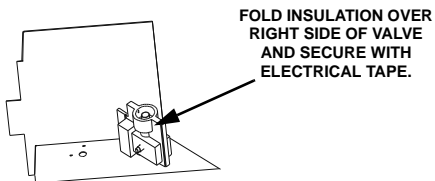

- C. Fold insulation and hold against right hand side of valve while securing with electrical tape. Seal the line set insulation to the shut-off valve insulation with electrical tape.

3 PHASE SCROLL COMPRESSOR ROTATION CVD2075 ONLY

A trained and qualified technician must verify compressor rotation at equipment startup or compressor warranty will be void. Incorrect rotation of a scroll compressor can be identified by:

- Noisy compressor operation
- Elevated suction pressure
- Low discharge pressure
- Compressor trips on overload protector

To change compressor rotation, reverse (exchange locations) any two incoming power supply leads.

CONDENSING UNIT HEAT OF REJECTION

Series Condensing Unit	Heat of Rejection*	
	A/C**	Peak
CVD0675	9,000	13,900
CVD0875	12,400	19,500
CVD1075	16,000	24,700
CVD1475 CVD1476	24,000	35,000
CVD1875	28,000	42,000
CVD2075	39,000	53,000

*B.T.U./Hour
**Because the heat of rejection varies during the ice making cycle, the figure shown is an average.

Ice machines, like other refrigeration equipment, reject heat through the condenser. It is necessary to know the amount of heat rejected by an ice machine when determining the additional BTUH requirements for air conditioning equipment.

- Self-contained air-cooled ice machines add the total BTUH load to a conditioned space.
- QuietQube® Ice Machine head sections add an insignificant amount of load to a conditioned space.

Operational Checks

GENERAL

Your Manitowoc ice machine was factory-operated and adjusted before shipment. Normally, a newly installed ice machine does not require any adjustment.

To ensure proper operation, always perform these Operational Checks when starting the ice machine:

- For the First Time
- After a Prolonged Out-of-Service Period
- After Cleaning and Sanitizing

Routine adjustments and maintenance procedures outlined in this manual are not covered by the warranty.

WATER LEVEL

Q0600C/Q0800C/Q1000C/QDUAL

The water level sensor is set to maintain the proper water level above the water pump housing. The water level is not adjustable.

If the water level is incorrect, check the water level probe for damage (probe bent, etc.). Clean, repair or replace the probe as necessary.

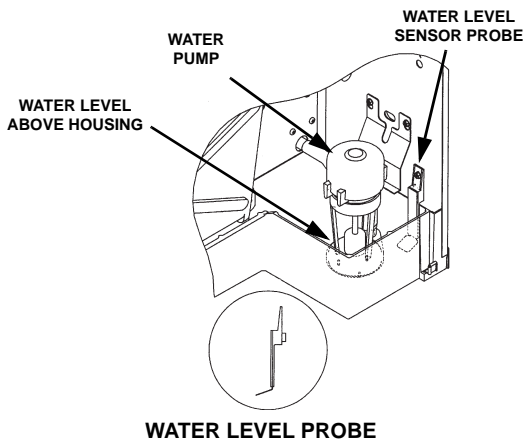

Q1400C/SU1000C

1. Check the water level while the ice machine is in the Clean mode and the water pump is running. The correct water level above the water pump impeller housing is:
 - Q1400C - 1/8-1/2 in. (3-12.5 mm)
 - SU1000C - 1/8-1/4 in. (3-6.35 mm)
2. The float valve is factory-set for the proper water level. If adjustments are necessary:
 - A. Loosen the two screws on the float valve bracket.
 - B. Raise or lower the float valve assembly as necessary, then tighten the screws.

If further adjustment is required, carefully bend the float arm to achieve the correct water level.

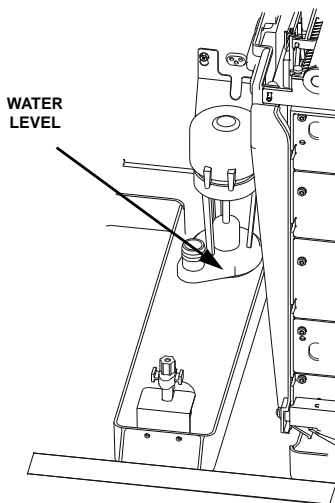

ICE THICKNESS CHECK

After a Harvest cycle, inspect the ice cubes in the ice storage bin. The ice thickness probe is set to maintain an ice bridge of 1/8 in. (3.2 mm). If an adjustment is needed, follow the steps below.

1. Turn the ice thickness probe adjustment screw clockwise for a thicker ice bridge, or counterclockwise for a thinner ice bridge.

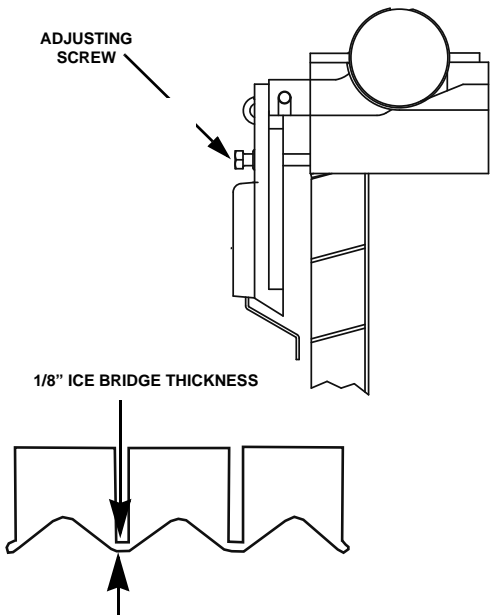

ICE THICKNESS ADJUSTMENT

2. Make sure the ice thickness probe wire and bracket do not restrict movement of the probe.

HARVEST SEQUENCE WATER PURGE

Q0600C/Q0800C/Q1000C/SU1000C/QDUAL

The Harvest sequence water purge adjustment may only be used when the ice machine is hooked up to special water systems, such as a de-ionized water treatment system.

Important

The Harvest sequence water purge is factory-set at 45 seconds. A shorter purge setting (with standard water supplies such as city water) is not recommended. This can increase water system cleaning and sanitizing requirements.

- The Harvest sequence water purge may be set to 15, 30, or 45 seconds.
- During the Harvest sequence water purge, the water fill valve energizes and de-energizes by time. The water purge must be at the factory setting of 45 seconds for the water fill valve to energize during the last 15 seconds of the water purge. If it is set to less than 45 seconds, the water fill valve will not energize during the water purge.

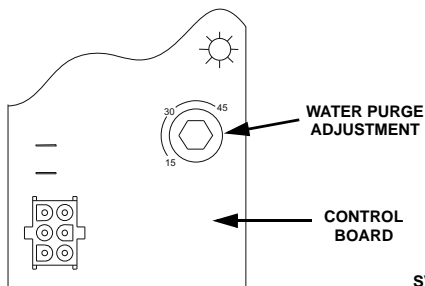

SV1208

Interior Cleaning and Sanitizing

NOTE: Clean and sanitize the ice machine every six months for efficient operation. If the ice machine requires more frequent cleaning and sanitizing, consult a water care professional to test the water quality and recommend appropriate water treatment or installation of the AuCS® (Automatic Cleaning System) Accessory. If required, an extremely dirty ice machine may be taken apart for cleaning and sanitizing.

Caution

Use only Manitowoc approved Ice Machine Cleaner (part number 94-0546-3) and Sanitizer (part number 94-0565-3). It is a violation of Federal law to use these solutions in a manner inconsistent with their labeling. Read and understand all labels printed on bottles before use.

Caution

Do not mix Ice Machine Cleaner and Sanitizer solutions together. It is a violation of Federal law to use these solutions in a manner inconsistent with their labeling.

Warning

Wear rubber gloves and safety goggles (and/or face shield) when handling Ice Machine Cleaner or Sanitizer.

NOTE: The SU1024YC is designed for installation on a SerVend UC-300 dispenser only. Refer to the SerVend UC-300 Installation, Use and Care Manual for dispenser cleaning/sanitizing procedures.

Manitowoc's Patented Cleaning or Sanitizing Technology

Manitowoc ice machines include technology that allows the initiation and completion of a cleaning or sanitizing cycle at the flip of a switch. This cycle will permit cleaning or sanitizing of all surfaces that come in contact with the water distribution system. Periodic maintenance must be performed that includes sanitizing the bin (or dispenser) and adjacent surface areas, which cannot be contacted by the water distribution system.

This technology will also allow initiation and completion of a Clean or Sanitize cycle, after which the ice machine automatically starts ice making again. Refer to the cleaning or sanitizing procedure for complete details.

The AuCS[®] Accessory can be set to automatically start and finish a Clean or Sanitize cycle every 2, 4, or 12 weeks. This accessory monitors ice-making cycles and initiates a cleaning or sanitizing cycle automatically. After completion of the cleaning or sanitizing cycle, the ice machine returns to ice making automatically. Refer to Automatic Cleaning System (AuCS[®]) Accessory for further details.

ALPHASAN®

The goal of AlphaSan® is to keep the plastic surfaces of an ice machine cleaner, by reducing or delaying the formation of biofilm. The active ingredient in AlphaSan® is the element silver in the form of silver ions (Ag^+). AlphaSan® slowly releases silver ions via an ion exchange mechanism. When AlphaSan® is compounded directly into a plastic part, a controlled release of silver ions from the surface is regulated to maintain an effective concentration at or near the surface of the plastic ice machine part.

AlphaSan's® unique ability to effectively control the release of silver not only protects against undesired discoloration of the plastic, but also will last the life of the plastic part. Although AlphaSan helps prevent biofilm build up it does not eliminate the need for periodic cleaning and maintenance. AlphaSan® has no adverse effect on the taste of the ice or beverage.

CLEANING PROCEDURE

Ice machine cleaner is used to remove lime scale or other mineral deposits. It is not used to remove algae or slime. Refer to “Sanitizing Procedure” on page 39 for removal of algae and slime. To initiate a cleaning cycle using Manitowoc’s Patented Cleaning Technology, use the following procedure.

Step 1. Set the toggle switch to the OFF position after ice falls from the evaporator at the end of a Harvest cycle. Or, set the switch to the OFF position and allow the ice to melt off the evaporator.



Caution

Never use anything to force ice from the evaporator. Damage may result.

Step 2. To start a cleaning cycle, move the toggle switch to the CLEAN position. The water will flow through the water dump valve and down the drain. The Clean light* will turn on to indicate the ice machine is in the cleaning mode.

Step 3. Wait about one minute or until water starts to flow over the evaporator.

Step 4. Add the proper amount of Manitowoc Ice Machine Cleaner to the water trough.

QuietQube® Models	Amount of Cleaner
Q0600C/Q0800C/ SU1000C/Q1400C	5 ounces (150 ml)
Q1000C/QDUAL	9 ounces (270 ml)

*The Q1400C ice machine control board does not energize a Clean light.

Step 5. The ice machine will automatically time out a ten-minute cleaning cycle, followed by six Rinse cycles, and then stop. The Clean light* will turn off to indicate the cleaning mode is completed. This entire cycle lasts approximately 25 minutes.

NOTE: Periodic cleaning must be performed on adjacent surface areas not contacted by the water distribution system.

Step 6. When the cleaning process stops, move the toggle switch to the OFF position. Refer to “Sanitizing Procedure” on page 39.

Step 7.**

- A. The ice machine may be set to start and finish a cleaning procedure, and then automatically start ice making again.
- B. Wait about one minute into the cleaning cycle (until water starts to flow over the evaporator), then move the switch from CLEAN to ICE position.
- C. When the cleaning cycle is completed, the Clean light will turn off and an ice making sequence will start automatically.

NOTE: After the toggle switch is moved to the ICE position, opening the curtain (bin switch) will interrupt the cleaning sequence. The sequence will resume from the point of interruption when the curtain (bin switch) closes.

NOTE: The SU1024YC is designed for installation on a SerVend UC-300 dispenser only. Refer to the SerVend UC-300 Installation Use and Care Manual for dispenser cleaning/sanitizing procedures.

*The Q1400C ice machine control board does not energize a Clean light.

**The Q1400C ice machine control board can not perform step 7, and must remain in the CLEAN position until the Clean cycle is finished. Moving the toggle switch to the ICE position will initiate a Freeze cycle.

SANITIZING PROCEDURE

Use sanitizer to remove algae or slime. Do not use it to remove lime scale or other mineral deposits. To initiate a sanitizing cycle using Manitowoc's Patented Cleaning/Sanitizing Technology, use the following procedure.

Step 1. Set the toggle switch to the OFF position after ice falls from the evaporator at the end of a Harvest cycle. Or, set the switch to the OFF position and allow the ice to melt off the evaporator.

Caution

Never use anything to force ice from the evaporator. Damage may result.

Step 2. To start a sanitizing cycle, move the toggle switch to the CLEAN position. The water will flow through the water dump valve and down the drain. The Clean light* will turn on to indicate the ice machine is in the cleaning mode.

Step 3. Wait about one minute or until water starts to flow over the evaporator.

Step 4. Add the proper amount of Manitowoc Ice Machine Sanitizer to the water trough.

QuietQube® Models	Amount of Sanitizer
Q0600C/Q0800C/Q1000C/ SU1000C/Q1400C	3 ounces (90 ml)
QDUAL	6 ounces (180 ml)

*The Q1400C ice machine control board does not energize a Clean light.

Step 5. The ice machine will automatically time out a ten-minute sanitizing cycle, followed by six Rinse cycles, and then stop. The Clean light* will turn off to indicate the sanitizing mode is completed. This entire cycle lasts approximately 25 minutes.

NOTE: Periodic cleaning must be performed on adjacent surface areas not contacted by the water distribution system. If the bin requires sanitizing, remove all of the ice and sanitize it with a solution of 1 oz. (30 ml) of sanitizer with up to 4 gal. (15 l) of water.

Step 6. When the sanitizing process stops, move the toggle switch to the ICE position to start ice making again.

Step 7.**

- A. The ice machine may be set to start and finish a sanitizing procedure, and then automatically start ice making again.
- B. Wait about one minute into the sanitizing cycle (until water starts to flow over the evaporator), then move the switch from CLEAN to ICE position.
- C. When the sanitizing cycle is completed, the Clean light will turn off and an ice making sequence will start automatically.

NOTE: After the toggle switch is moved to the ICE position, opening the curtain (bin switch) will interrupt the cleaning sequence. The sequence will resume from the point of interruption when the curtain (bin switch) closes.

NOTE: The SU1024YC is designed for installation on a SerVend UC-300 dispenser only. Refer to the SerVend UC-300 Installation Use and Care Manual for dispenser cleaning/sanitizing procedures.

*The Q1400C ice machine control board does not energize a Clean light.

**The Q1400C ice machine control board can not perform step 7, and must remain in the CLEAN position until the Clean cycle is finished. Moving the toggle switch to the ICE position will initiate a Freeze cycle.

Automatic Cleaning System (AuCS®) Accessory

This accessory monitors ice-making cycles and initiates cleaning (or sanitizing) procedures automatically. The AuCS® Accessory can be set to automatically clean or sanitize the ice machine every 2, 4, or 12 weeks. Periodic maintenance must be performed that includes cleaning or sanitizing the bin (or dispenser) and adjacent surface areas, which can not be contacted by the water distribution system.



Caution

Refer to the AuCS® Accessory Installation, Use and Care Guide for complete details on the installation, operation, maintenance and cautionary statements of this accessory.

AUTOMATIC OPERATION

The following occurs when the toggle switch is in the ICE position:

- The ice machine control board counts the number of ice Harvest cycles.
- The AuCS® Accessory interrupts the ice making mode and starts the cleaning (or sanitizing) mode when the harvest count equals the “Frequency of Cleaning” setting of the AuCS®.
- When the automatic cleaning (or sanitizing) cycle is complete (approximately 25 minutes), ice making resumes automatically, and the “Harvest Count” is reset to zero.

Important

Opening the curtain switch will interrupt the cleaning or sanitizing sequence. The sequence will resume from the point of interruption when the curtain recloses.

MANUAL START OPERATION

Step 1. Set the toggle switch to the OFF position after ice falls from the evaporator at the end of a Harvest cycle. Or, set the switch to the OFF position and allow the ice to melt off the evaporator.

Caution

Never use anything to force ice from the evaporator. Damage may result.

Step 2. To start the automatic cleaning system, move the toggle switch to the CLEAN position. The water will flow through the water dump valve and down the drain. The Clean light* will turn on to indicate the ice machine is in the cleaning mode. The AuCS® then automatically adds cleaner or sanitizer to the ice machine.

Step 3. The ice machine will automatically time out a ten-minute cleaning or sanitizing cycle, followed by six Rinse cycles, de-energize the Clean light* and stop. This entire cycle lasts approximately 25 minutes.

Step 4. After the cleaning or sanitizing cycle stops, move the toggle switch to ICE position.

Step 5.**

- A. The ice machine may be set to start and finish a cleaning or sanitizing cycle, then automatically start ice making again.
- B. You must wait about one minute into the cleaning cycle (until water starts to flow over the evaporator), then move the toggle switch from CLEAN to ICE position.
- C. When the cleaning or sanitizing cycle is completed, the Clean light will turn off and an ice-making sequence will start automatically.

*The Q1400C ice machine control board does not energize a Clean light.

**The Q1400C ice machine control board can not perform step 7, and must remain in the CLEAN position until the Clean cycle is finished. Moving the toggle switch to the ICE position will initiate the Rinse cycles. The six Rinse cycles must be completed before a Freeze cycle can be initiated.

Removal of Parts for Cleaning or Sanitizing

1. Turn off the water supply to the ice machine at the water service valve.



Warning

Disconnect electric power to the ice machine at the electric switch box before proceeding.

2. Remove the water curtain and the components you want to clean or sanitize. See the following pages for removal procedures for these parts.



Warning

Wear rubber gloves and safety goggles (and/or face shield) when handling Ice Machine Cleaner or Sanitizer.

3. Soak the removed part(s) in a properly mixed solution.

Solution Type	Water	Mixed With
Cleaner	1 gal. (4 l)	16 oz. (500 ml) cleaner
Sanitizer	4 gal. (15 l)	1 oz. (30 ml) sanitizer

4. Use a soft-bristle brush or sponge (NOT a wire brush) to carefully clean the parts.



Warning

Do not mix Cleaner and Sanitizer solutions together. It is a violation of Federal law to use these solutions in a manner inconsistent with their labeling.

 **Caution**

Do not immerse the water pump motor in the cleaning or sanitizing solution.

5. Use the solution and a brush to clean the top, sides, and bottom evaporator extrusions; the inside of the ice machine panels; and the entire inside of the bin.
6. Thoroughly rinse all of the parts and surfaces with clean water.
7. Install the removed parts.

NOTE: Incomplete rinsing of the ice thickness probe or water level probe may leave a residue. This could cause the ice machine to malfunction. For best results, brush or wipe the probe off while rinsing it. Thoroughly dry the probe before installing it.

8. Turn on the water and electrical supply.
9. Verify the ice thickness probe is properly adjusted.

WATER DUMP VALVE

The water dump valve normally does not require removal for cleaning. To determine if removal is necessary:

1. Locate the water dump valve.
2. Set the toggle switch to ICE.
3. While the ice machine is in the Freeze mode, check the dump valve's clear plastic outlet drain hose for leakage.
 - A. If the dump valve is leaking, remove, disassemble and clean it.
 - B. If the dump valve is not leaking, do not remove it. Instead, follow standard ice machine cleaning procedures.

Follow the procedure below to remove the dump valve.



Warning

Disconnect the electric power to the ice machine at the electric service switch box and turn off the water supply before proceeding.

1. If so equipped, remove the water dump valve shield from its mounting bracket.
2. Lift and slide the coil retainer cap from the top of the coil.
3. Note the position of the coil assembly on the valve for assembly later. Leaving the wires attached, lift the coil assembly off the valve body and the enclosing tube.
4. Press down on the plastic nut on the enclosing tube and rotate it 1/4 turn. Remove the enclosing tube, plunger, and plastic gasket from the valve body.

NOTE: At this point, the water dump valve can easily be cleaned. If complete removal is desired, continue with step 5.

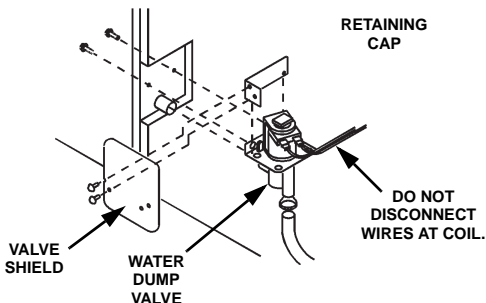

DUMP VALVE REMOVAL

Important

The plunger and the inside of the enclosing tube must be completely dry before assembly.

NOTE: During cleaning, do not stretch, damage or remove the spring from the plunger. If it is removed, slide the spring's flared end into the plunger's slotted top opening until the spring contacts the plunger spring stop.

5. Remove the valve body.
6. Remove the tubing from the dump valve by twisting the clamps off.

Remove the two screws securing the dump valve and the mounting bracket.

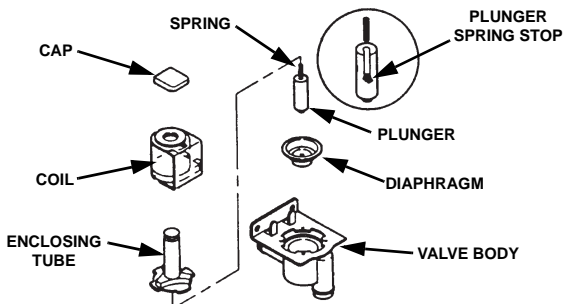

DUMP VALVE DISASSEMBLY

WATER PUMP

Warning

Disconnect the electric power to the ice machine at the electric service switch box and turn off the water supply.

1. Disconnect the water pump power cord.

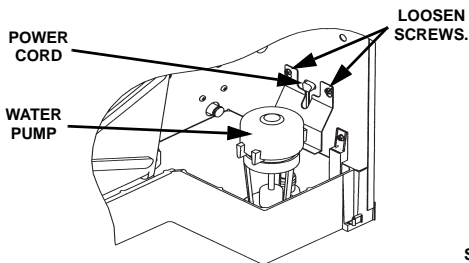

SV1618

WATER PUMP REMOVAL (Q0600C/Q0800C/Q1000C SHOWN)

2. Disconnect the hose from the pump outlet.
3. Loosen the screws securing the pump, mounting bracket to the bulkhead.
4. Lift the pump and bracket assembly off the screws.

ICE THICKNESS PROBE

1. Compress the side of the ice thickness probe near the top hinge pin and remove it from the bracket.

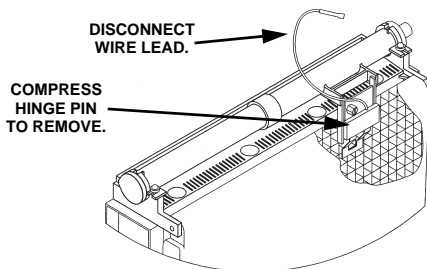

SV1619

ICE THICKNESS PROBE REMOVAL

NOTE: At this point, the ice thickness probe can easily be cleaned. If complete removal is desired, continue with step 2 below.

Warning

Disconnect the electric power to the ice machine at the electric service switch box and turn off the water supply.

2. Disconnect the wire lead from the control board inside the electrical control box.

WATER LEVEL PROBE

Q0600C/Q0800C/Q1000C/QDUAL

1. Loosen the screw that holds the water level probe in place. The probe can easily be cleaned at this point without proceeding to step 2.

Warning

Disconnect the electrical power to the ice machine at the electrical disconnect before proceeding.

2. If complete removal is required, disconnect the wire lead from the control board (1F) inside the electrical control box.

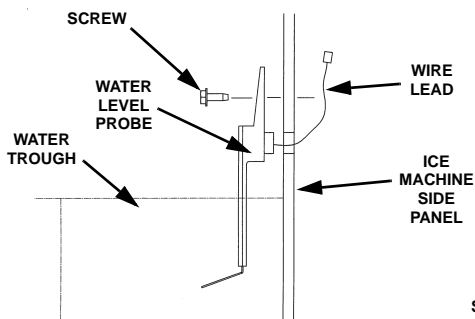

WATER LEVEL PROBE REMOVAL
Q0600C/Q0800C/Q1000C Shown

SV1621

SPLASH SHIELD

Q1400C/QDUAL

1. Pull forward on left and right Nylatch connectors until disengaged from ice machine (connectors remain attached to splash shield).
2. Remove panel from front of ice machine by lifting forward and up.

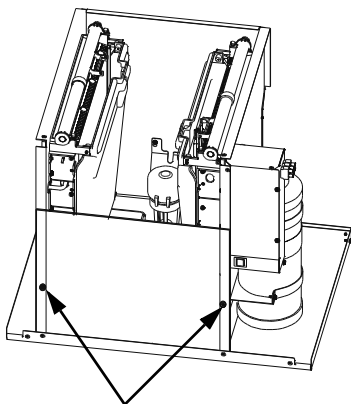

**NYLATCH CONNECTORS
PULL FORWARD TO
DISENGAGE.**

Q1400 Shown

Important

Splash shield must be reinstalled to prevent water leakage.

WATER CURTAIN

1. Gently flex the curtain in the center and remove it from the right side.

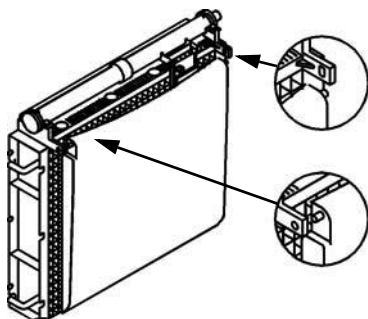

SV1213

WATER CURTAIN REMOVAL

2. Slide the left pin out.

FLOAT VALVE

SU1000C/Q1400C

1. Turn off the water supply to the ice machine at the water service valve.
2. Turn the splash shield counterclockwise one or two turns.

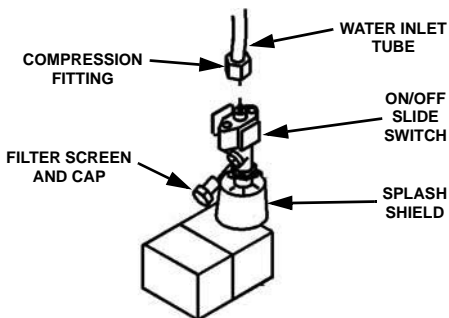

SV1217

FLOAT VALVE REMOVAL

3. Pull the float valve forward and off the mounting bracket.
4. Disconnect the water inlet tube from the float valve at the compression fitting.
5. Remove the filter screen and cap for cleaning.

WATER INLET VALVE

Q0600C/Q0800C/Q1000C/QDUAL

The water inlet valve normally does not require removal for cleaning. Follow the instructions below to determine if removal is necessary.

1. Set the ICE/OFF/CLEAN switch to OFF. Locate the water inlet (in the water area of the ice machine). It directs water into the water trough.
2. When the ice machine is off, the water inlet valve must completely stop water flow into the machine. Watch for water flow. If water flows, remove, disassemble and clean the valve.
3. When the ice machine is on, the water inlet valve must allow the proper water flow through it. Set the toggle switch to ON. Watch for water flow into the ice machine. If the water flow is slow or only trickles into the ice machine, remove, disassemble, and clean the valve.



Warning

Disconnect the electric power to the ice machine at the electric service switch box and turn off the water supply before proceeding.

Continued on Next Page...

Follow the procedure below to remove the water inlet valve.

1. Remove the valve shield if necessary.
2. Remove the filter access screws that hold the valve in place.

NOTE: The water inlet valve can be disassembled and cleaned without disconnecting the incoming water supply line to the ice machine.

3. Remove, clean, and install the filter screen.
4. If necessary, remove the enclosing tube access screws to clean interior components.

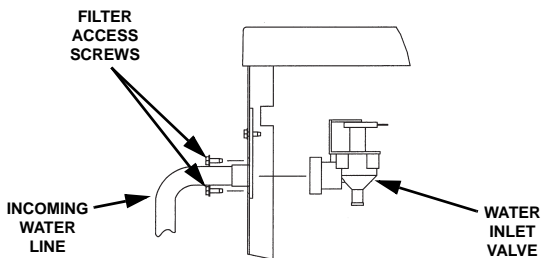

WATER INLET VALVE REMOVAL

SV1622

WATER DISTRIBUTION TUBE

1. Disconnect the water hose from the distribution tube.

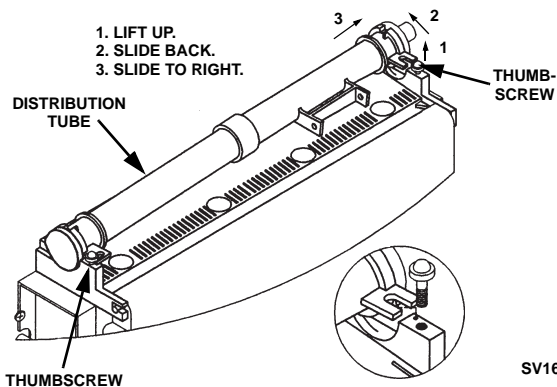

WATER DISTRIBUTION TUBE REMOVAL

2. Loosen the thumbscrews, which secure the distribution tube.
3. Lift the end of the distribution tube with the hose fitting up, and then slide it back and to the right.

Caution

Do not force this removal. Be sure the locating tab is clear before sliding the distribution tube back.

4. Disassemble for cleaning.

A. Twist both of the inner tube ends until the tabs line up with the keyways.

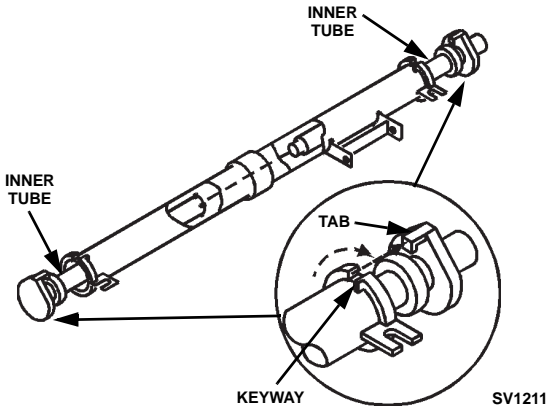

WATER DISTRIBUTION TUBE DISASSEMBLY

B. Pull the inner tube ends outward.

WATER TROUGH REMOVAL

Q1400C/QDUAL

1. Remove the front splash shield, water pump and float valve from the ice machine.
2. Remove the quarter turn fasteners (turn counterclockwise) securing the trough in place.
3. Lift up and forward on the front of the water trough while allowing the rear of the water trough to drop. Remove the water trough from the ice machine.

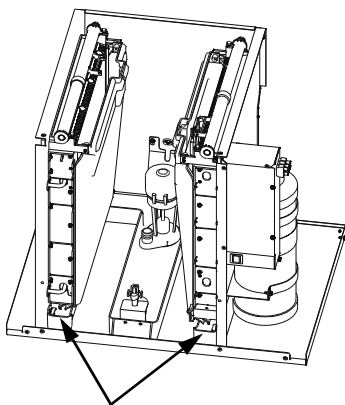

REMOVE THE TWO
QUARTER TURN
FASTENERS BY TURNING
COUNTERCLOCKWISE.

SV1771B

WATER TROUGH REMOVAL

WATER TROUGH REMOVAL

SU1000C (SerVend UC-300 Dispenser)

1. Remove the quarter turn fasteners (turn counterclockwise) securing the trough in place.
2. Pull forward on the water trough until the rear pins disengage from the water trough.
3. Lift up and forward on the front of the water trough while allowing the rear of the water trough to drop.
4. Remove the water trough from the ice machine.

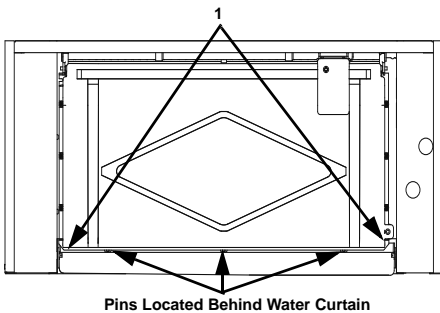

Removal from Service/Winterization

GENERAL

Special precautions must be taken if the ice machine is to be removed from service for an extended period of time or exposed to ambient temperatures of 32°F (0°C) or below.

Caution

If water is allowed to remain in the ice machine in freezing temperatures, severe damage to some components could result. Damage of this nature is not covered by the warranty.

1. Place the ice machine toggle switch in the OFF position.
2. Turn off the water supply.
3. Remove the water from the water trough.
4. Disconnect and drain the incoming ice-making water line at the rear of the ice machine.
5. Blow compressed air in the drain openings in the rear of the ice machine until no more water comes out of the drain.
6. Place the toggle switch in the ICE position, then wait 45 seconds for the water fill solenoid valve to energize. Blow compressed air through the incoming water supply in the rear of the ice machine until no more water comes out of the inlet water line.
7. Make sure water is not trapped in any of the water lines, drain lines, distribution tubes, etc.

CVD1476 WATER COOLED CONDENSING UNIT

Place the ice machine toggle switch into the OFF position.

1. "Front seat" (shut off) the receiver service valve. Hang a tag on the switch as a reminder to open the valve before restarting.
2. Perform steps 1-6 under "Q1400C Head Section".
3. Insert a large screwdriver between the bottom spring coils of the water regulating valve. Pry upward to open the valve.
4. Hold the valve open and blow compressed air through the condenser until no water remains.

AuCS® ACCESSORY

Refer to the AuCS® Accessory manual for Winterization of the AuCS® Accessory.

Component Identification

ICE MACHINE HEAD SECTION

Q0600C/Q0800C/Q1000C

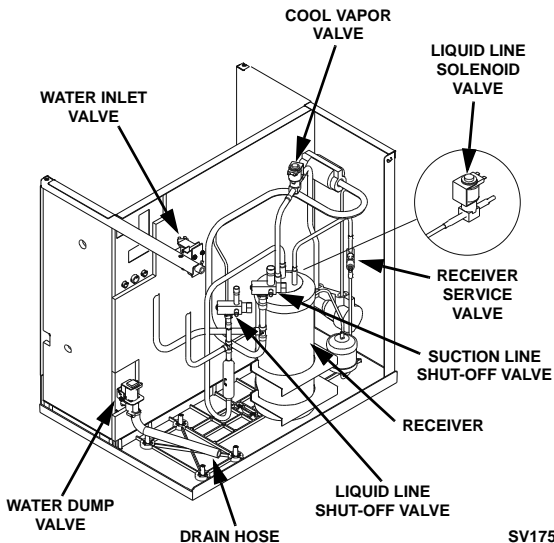

SV1754

Q0600C/Q0800C/Q1000C

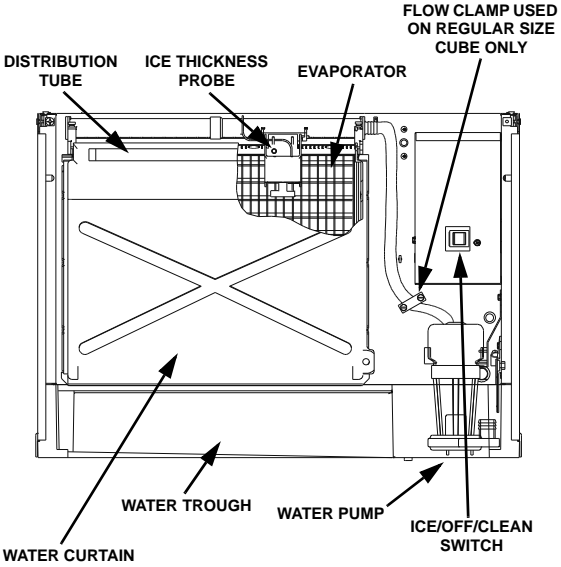

SV1605A

SU1000C/SerVend UC-300 Dispenser

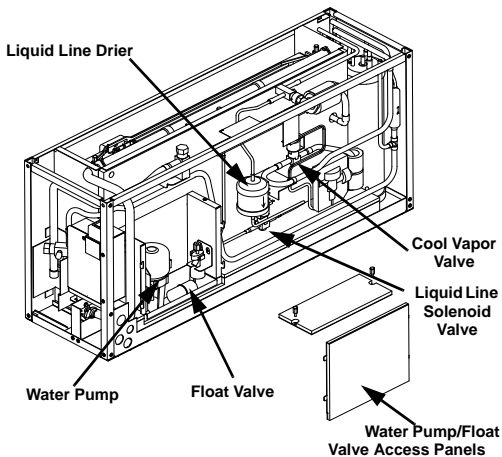
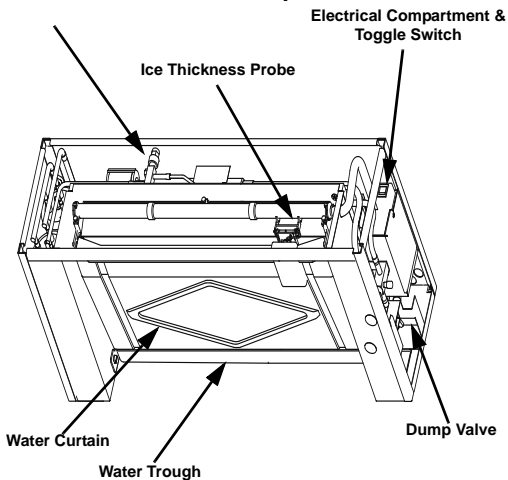

Q1400C

Receiver Service Valve

ICE
THICKNESS
PROBE

COOL VAPOR
VALVE

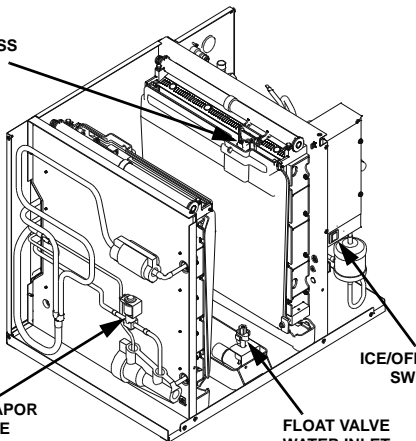

ICE/OFF/CLEAN
SWITCH

FLOAT VALVE
WATER INLET

SV1770LH

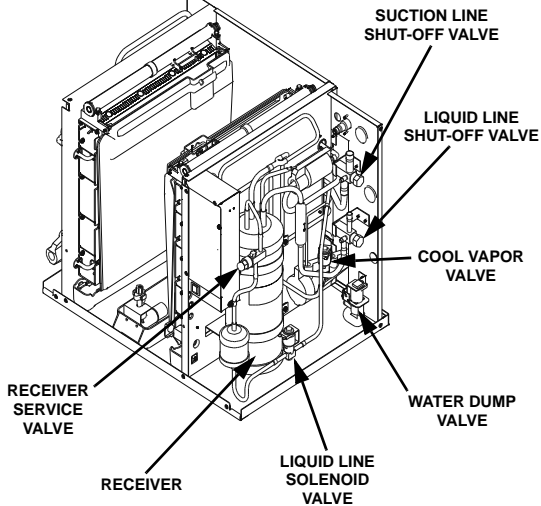

SUCTION LINE
SHUT-OFF VALVE

LIQUID LINE
SHUT-OFF VALVE

COOL VAPOR
VALVE

WATER DUMP
VALVE

RECEIVER
SERVICE
VALVE

RECEIVER

LIQUID LINE
SOLENOID
VALVE

SV1770RH

QDUAL

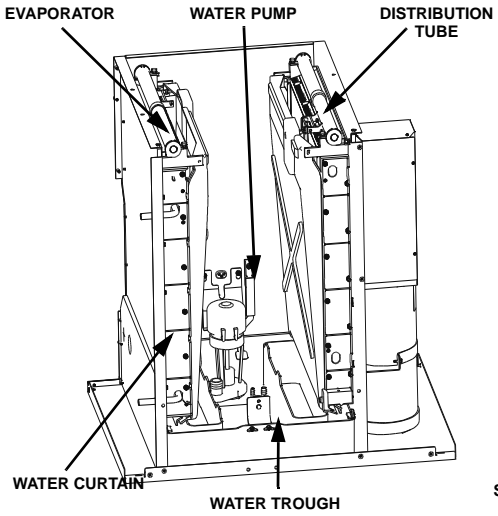

SV1780

CVD® CONDENSING UNIT

CVD0675/CVD0875/CVD1075/CVD1475

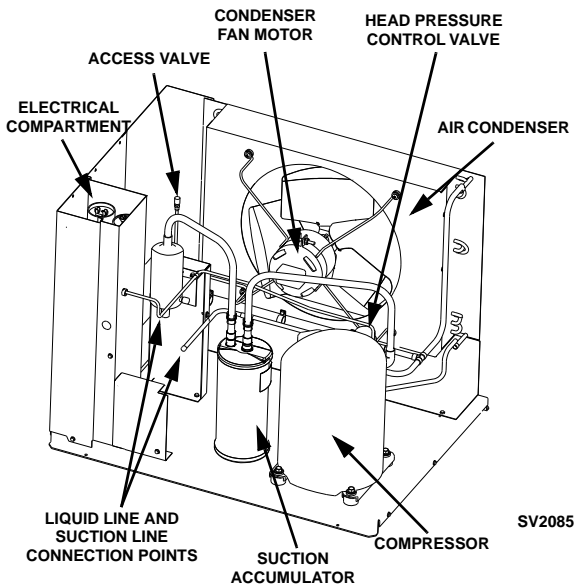

CVD1476

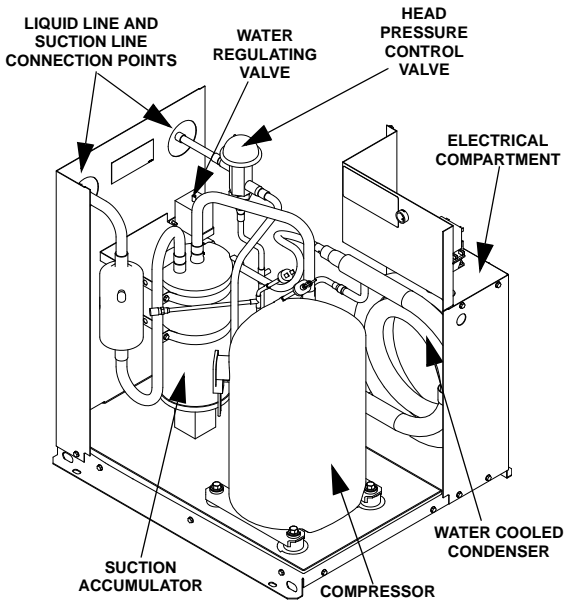

CVD1875/CVD2075

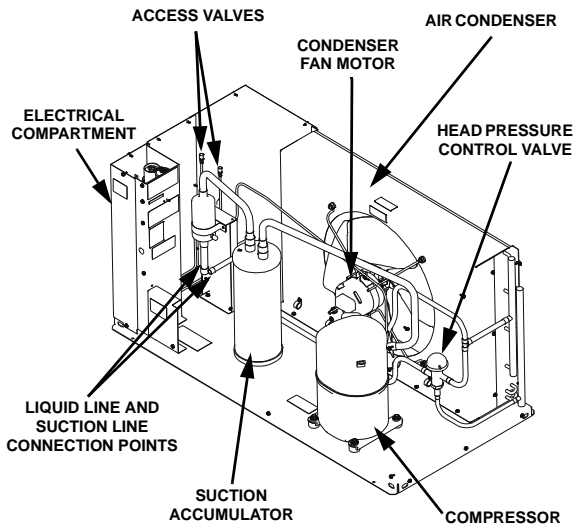

CVD1875 SHOWN

Ice Making Sequence of Operation

Q0600C/Q0800C/Q1000C/SU1000C

Initial Start-Up or Start-Up After Automatic Shut-Off

1. Water Purge

Before the compressor starts, the water pump and water dump solenoid are energized for 45 seconds to purge the ice machine of old water. This ensures that the ice-making cycle starts with fresh water.

The cool vapor solenoid valve is also energized during the water purge, although it stays on for an additional 5 seconds (50-second total on time) during the initial refrigeration system start-up.

2. Refrigeration System Start-Up

Ice Machine Section: The liquid line solenoid valve energizes after the 45-second water purge, and remains on throughout the entire Freeze and Harvest sequences. The cool vapor solenoid valve remains on for 5 seconds during initial compressor start-up and then shuts off.

The water fill valve is energized at the same time as the liquid line solenoid valve.

CVD® Condensing Unit: When the refrigerant pressure is high enough to close the low-pressure control (after the cool vapor valve energizes in step 1), the contactor coil is energized and the compressor starts. The compressor and fan cycling control* are supplied with power throughout the entire Freeze and Harvest sequences. When the refrigerant pressure is high enough to close the fan cycling pressure control, the condenser fan motor starts.

*The Q0600C ice machines does not use a fan cycling control. The compressor and the condenser fan motor are wired through the contactor. Anytime the contactor coil is energized, these components are supplied with power.

Freeze Sequence

3. Prechill

The compressor is on for 30 seconds prior to water flow to prechill the evaporator. The water fill valve remains on until the water level probe is satisfied.

4. Freeze

The water pump restarts after the 30-second prechill. An even flow of water is directed across the evaporator and into each cube cell, where it freezes. The water fill valve will cycle on, then off one more time to refill the water trough.

When sufficient ice has formed, the water flow (not the ice) contacts the ice thickness probe. After approximately 7 seconds of continual water contact, the Harvest sequence is initiated. The ice machine cannot initiate a Harvest sequence until a 6-minute freeze lock has been surpassed.

Harvest Sequence

5. Water Purge

The water pump continues to run, and the water dump valve energizes for 45 seconds to purge the water in the sump trough. The water fill valve energizes for the last 15 seconds of the 45-second water purge.

After the 45-second water purge, the water fill valve, water pump and dump valve de-energize. (Refer to “Water Purge Adjustment” for details.)

The cool vapor solenoid valve also opens at the beginning of the water purge to divert refrigerant gas into the evaporator.

When the refrigerant pressure is low enough to open the fan cycling pressure control,* the condenser fan motor stops.

*The Q0600C ice machine does not use a fan cycle control; therefore the condenser fan motor will continue to run in the Harvest cycle.

6. Harvest

The cool vapor solenoid valve remains open and the refrigerant gas warms the evaporator causing the cubes to slide as a sheet, off the evaporator and into the storage bin. The sliding sheet of cubes swings the water curtain out, opening the bin switch.

The momentary opening and reclosing of the bin switch terminates the Harvest sequence and returns the ice machine to the Freeze sequence (steps 3-4).

Automatic Shut-Off

7. Automatic Shut-Off

Ice Machine Section: When the storage bin is full at the end of a Harvest sequence, the sheet of ice cubes fails to clear the water curtain and will hold it open. After the water curtain is held open for 7 seconds, the ice machine shuts off. The ice machine remains off for 3 minutes before it can automatically restart.

CVD® Condensing Unit: The liquid line solenoid valve closes, allowing the refrigeration system to pump down. When the refrigerant pressure is low enough to open the fan cycling pressure control,* the condenser fan motor stops. When the refrigerant pressure is low enough to open the low-pressure control, the contactor coil is de-energized and the compressor stops.

The ice machine remains off until enough ice has been removed from the storage bin to allow the ice to fall clear of the water curtain. As the water curtain swings back to the operating position, the bin switch recloses and the ice machine restarts (steps 1-2), provided the 3-minute delay period is complete.

*The Q0600C ice machine does not use a fan cycle control; therefore the condenser fan motor will energize and de-energize with the compressor.

Q600C/Q800C/Q1000C/SU1000C Energized Parts Chart

Ice Making Sequence of Operation	Control Board Relays					Condensing Unit		Length of Time
	1 Water Pump	2 Water Fill Valve	3 Cool Vapor Valve	4 Water Dump Valve	5 Liquid Line Solenoid	LPC Contactor Coil	Contactor Comp Fan Motor*	
Initial Start-Up 1. Water Purge	On	Off	On	On	Off	Closed On	Off	45 Seconds
	2. Refrigeration System Start-Up	Off	On	On	Off	On	Closed On	On
Freeze Sequence 3. Prechill	Off	May Cycle On/Off During First 45 Sec.	Off	Off	On	Closed On	On	30 Seconds
4. Freeze	On	Cycles Off Then On One More Time Locked out After 6 min.	Off	Off	On	Closed On	On	Unit 7 Sec. Water Contact w/Ice Thickness Probe

Q600C/Q800C/Q1000C/SU1000C Energized Parts Chart

Ice Making Sequence of Operation	Control Board Relays					Condensing Unit		Length of Time
	1 Water Pump	2 Water Fill Valve	3 Cool Vapor Valve	4 Water Dump Valve	5 Liquid Line Solenoid	LPC Contactor Coil	Contactora Comp Fan Motor*	
Harvest Sequence								
5. Water Purge	On	30 Sec. Off, 15 Sec. On	On	On	On	Closed On	CVD675 On All others May Cycle On/Off	Factory Set at 45 Seconds
6. Harvest	Off	Off	On	Off	On	Closed On	CVD675 On All others May Cycle On/Off	Bin Switch Activation
7. Automatic Shut-Off	Off	Off	Off	Off	Off	Off	Off	Until Bin Switch Recloses

Q1400C

Initial Start-Up or Start-Up After Automatic Shut-Off

1. Water Purge

Before the refrigeration system starts, the water pump and water dump solenoid are energized for 45 seconds, to purge the ice machine of old water. This feature ensures that the ice making cycle starts with fresh water.

Freeze Sequence

2. Prechill

Ice Machine Section: The liquid line solenoid valve energizes after the 45-second water purge and remains on for the entire ice making Freeze and Harvest sequences. The liquid line solenoid is energized for 30 seconds prior to water flow. This allows the refrigeration system to start up and prechills the evaporator.

CVD® Condensing Unit: When the refrigerant pressure is high enough to close the low pressure switch, the contactor coil is energized and the compressor and condenser fan motor (CVD1475 only) start. They are supplied with power throughout the entire Freeze and Harvest sequences. The fan motor (CVD1475 only) is wired through a fan cycle pressure control, therefore it may cycle on and off.

3. Freeze

The water pump restarts after the 30-second prechill. An even flow of water is directed across the evaporator and into each cube cell, where it freezes.

When sufficient ice has formed, the water flow (not the ice) contacts the ice thickness probe. After approximately 7 seconds of continual water contact, the Harvest sequence is initiated. The ice machine cannot initiate a Harvest sequence until a 6-minute freeze lock has been surpassed.

Harvest Sequence

4. Water Purge

The water pump continues to run, and the water dump valve energizes for 45 seconds to purge the water in the sump trough. After the 45-second water purge, the water pump and dump valve de-energizes.

Both cool vapor solenoid valves also open at the beginning of the water purge to divert refrigerant gas into the evaporator.

5. Harvest

The cool vapor solenoid valves remain open, and the refrigerant gas warms each evaporator causing the cubes to slide as a sheet, off the evaporator and into the storage bin. The ice may fall first from either the right or the left evaporator, or both at the same time. The sliding sheet of cubes swings the water curtain out, opening the corresponding bin switch.

The momentary opening and closing of the bin switch de-energizes relay #2 (right) or #3 (left). Opening relay #2 or #3 de-energizes the corresponding cool vapor solenoid valve for the remainder of the Harvest sequence. The momentary opening and reclosing of both bin switches terminates the Harvest sequence and returns the ice machine to the Freeze sequence (steps 2-3).

Automatic Shut-Off

6. Automatic Shut-Off

Ice Machine Section: When the storage bin is full at the end of a Harvest sequence, the sheet of cubes fails to clear either one or both of the water curtains. After one or both water curtains are held open for 7 seconds, all five relays open and the ice machine shuts off.

CVD® Condensing Unit: When the refrigerant pressure is low enough to open the low pressure switch, the contactor coil is de-energized and the compressor and condenser fan motor (CVD1475 only) stop.

The ice machine remains off until enough ice has been removed from the storage bin to allow the ice to fall clear of the water curtain(s). As the water curtain swings back to the operating position, the bin switch recloses and the ice machine restarts (steps 1-2).

Energized Parts Chart – Model Q1400C

Ice Making Sequence of Operation	Control Board Relays					Condensing Unit		Length of Time
	1 Water Pump	2 Cool Vapor Valve Right	3 Cool Vapor Valve Left	4 Water Dump Valve	5 Liquid Line Solenoid Valve	LPCO* Contactor Coil	Contactor Condenser Fan Motor* Compressor	
Initial Start-Up 1. Water Purge	On	Off	Off	On	Off	Open	Off	<i>45 Seconds</i>
Freeze Sequence 2. Prechill	Off	Off	Off	Off	On	Closed	**On	<i>30 Seconds</i>

Energized Parts Chart – Model Q1400C (Continued)

Ice Making Sequence of Operation	Control Board Relays					Condensing Unit		Length of Time
	1 Water Pump	2 Cool Vapor Valve Right	3 Cool Vapor Valve Left	4 Water Dump Valve	5 Liquid Line Solenoid Valve	LPCO* Contactor Coil	Contactor Condenser Fan Motor* Compressor	
3. Freeze	On	Off	Off	Off	On	Closed	**On	<i>Unit 7 Sec. Water Contact w/Ice Thickness Probe</i>
Harvest Sequence								
4. Water Purge	On	On	On	On	On	Closed	**On	<i>Factory Set at 45 Seconds</i>
5. Harvest	Off	On	On	Off	On	Closed	**On	<i>Bin Switch Activation</i>

Energized Parts Chart – Model Q1400C (Continued)

Ice Making Sequence of Operation	Control Board Relays					Condensing Unit		Length of Time
	1 Water Pump	2 Cool Vapor Valve Right	3 Cool Vapor Valve Left	4 Water Dump Valve	5 Liquid Line Solenoid Valve	LPCO* Contactor Coil	Contactor Condenser Fan Motor* Compressor	
6. Automatic Shut-Off	Off	Off	Off	Off	Off	Open	Off	<i>Until BOTH Bin Switches Recloses</i>

*Low Pressure Control (close on pressure increase).

**CVD1375/CVD1475 ONLY - The fan motor is wired through a fan cycle pressure control, therefore, it may cycle on and off.

QDUAL

Initial Start-Up or Start-Up After Automatic Shut-Off

1. Water Purge

Before the refrigeration system starts, the water pump and water dump solenoid are energized for 45 seconds, to purge the ice machine of old water. This feature ensures that the ice-making cycle starts with fresh water. The cool vapor solenoid valves are also energized during the water purge, although they stay on for an additional 5 seconds (50 seconds total on time) then shut off.

2. Refrigeration System Start-Up

Ice Machine Section: The liquid line solenoid valve energizes after the 45-second water purge, and remains on throughout the entire Freeze and Harvest sequences. The cool vapor solenoid valves remain on for 5 seconds during initial compressor start-up and then shut off.

The water fill valve is energized at the same time as the liquid line solenoid valve.

CVD® Condensing Unit: When the refrigerant pressure is high enough to close the low pressure control (after the cool vapor valves energize in step 1), the contactor coil is energized and the compressor starts. The compressor and fan cycling control are supplied with power throughout the entire Freeze and Harvest sequences. When the refrigerant pressure is high enough to close the fan cycling pressure control, the condenser fan motor starts.

Freeze Sequence

3. Prechill

The liquid line solenoid is energized for 30 seconds prior to water flow. This allows the refrigeration system to start up and prechill the evaporator. The water fill valve remains energized until the water level sensor is satisfied.

4. Freeze

The water pump restarts after the 30-second prechill. An even flow of water is directed across the evaporator and into each cube cell, where it freezes. The water fill valve will cycle on one more time to refill the water trough as needed. When sufficient ice has formed, the water flow (not the ice) contacts the ice thickness probe. After approximately 10 seconds of continual water contact, the Harvest sequence is initiated. The ice machine cannot initiate a Harvest sequence until a 6-minute freeze lock has been surpassed.

Harvest Sequence

5. Water Purge

The water pump continues to run, and the water dump valve energizes for 45 seconds to purge the water in the sump trough. The water fill valve energizes for the last 15 seconds of the 45-second water purge. After the 45-second water purge, the water fill valve, water pump, and dump solenoid valve de-energize. The cool vapor solenoids open at the beginning of the water purge.

6. Harvest

The cool vapor valves remain open, and the refrigerant warms each evaporator causing the cubes to slide as a sheet, off the evaporator and into the storage bin. The ice may fall first from either the right or the left evaporator, or both at the same time. The sliding sheet of cubes swings the water curtain out, opening the corresponding bin switch and de-energizing the cool vapor valve. The momentary opening and reclosing of both bin switches terminates the Harvest sequence and returns the ice machine to the Freeze sequence (steps 3-4).

6A. Water Assist Harvest Feature

Typical duration of a Harvest sequence is less than 2.5 minutes. When the Harvest sequence time reaches 4 minutes, the following occurs:

4 minutes into a Harvest sequence: The water fill valve will energize to fill the trough with water.

5 minutes into a Harvest sequence: The water pump will energize and flow water over the evaporators.

The water fill valve and water pump remain on until all bin switches have been activated, or until the 7-minute Harvest sequence time limit is reached.

7. Automatic Shut-Off

Ice Machine Section: When the storage bin is full at the end of a Harvest sequence, the sheet of cubes fails to clear either one or both of the water curtains. After one or both water curtains are held open for *30 seconds, the ice machine shuts off.

*Note: Early production control boards checked for bin switch closure within 7 seconds.

CVD® Condensing Unit: When the refrigerant pressure is low enough to open the low pressure switch, the contactor coil is de-energized and the compressor and condenser fan motor stop.

The ice machine remains off until enough ice has been removed from the storage bin to allow the ice to fall clear of the water curtain(s). As the water curtains swing back to the operating position, the bin switch recloses and the ice machine restarts (steps 1-2), provided the 3-minute delay period is complete. Both curtains must be closed to start an ice-making sequence.

Energized Parts Chart – Model QDUAL

Ice Making Sequence of Operation	Control Board Relays						Condensing Unit		Length of Time
	1 Water Pump	2 Water Fill Solenoid	3 Dump Valve	4 Liquid Line Solenoid	5 Cool Vapor Valve 1	6 Cool Vapor Valve 2	LPCO* Contactor Coil	Contactora Fan Motor and Compressor	
Initial Start-Up									
1. Water Purge	On	Off	On	Off	On	On	Closed	On	<i>45 Seconds</i>
2. Refrigeration System Start-Up	Off	On	Off	On	On	On	Closed	**On	<i>5 Seconds</i>

Energized Parts Chart – Model QDUAL (Continued)

Ice Making Sequence of Operation	Control Board Relays						Condensing Unit		Length of Time
	1 Water Pump	2 Water Fill Solenoid	3 Dump Valve	4 Liquid Line Solenoid	5 Cool Vapor Valve 1	6 Cool Vapor Valve 2	LPCO* Contactor Coil	Contactors Fan Motor and Compressor	
Freeze Sequence									
3. Prechill	Off	On Until Water is Sensed	Off	On	Off	Off	Closed	**On	<i>30 Seconds</i>
4. Freeze	On	Cycles Off Then On 1 More Time	Off	On	Off	Off	Closed	**On	<i>Until 10 Sec. water cont act w/Ice Thickness Probe</i>
Harvest Sequence									
5. Water Purge	On	30 Sec. Off 15 Sec. On	On	On	On	On	Closed	**On	<i>Water Purge Factory Set at 45 Sec.</i>

Energized Parts Chart – Model QDUAL (Continued)

Ice Making Sequence of Operation	Control Board Relays						Condensing Unit		Length of Time
	1 Water Pump	2 Water Fill Solenoid	3 Dump Valve	4 Liquid Line Solenoid	5 Cool Vapor Valve 1	6 Cool Vapor Valve 2	LPCO* Contactor Coil	Contactor Fan Motor and Compressor	
6. Harvest	Off	Off	Off	On	On	On	Closed	**On	<i>Bin Switch Activation</i>
7. Auto Shut-Off	Off	Off	Off	Off	Off	Off	Open	Off	<i>Until Bin Switch Recloses</i>

*Low pressure Control (close on pressure increase).

**The fan motor is wired through a fan cycle pressure control, therefore, it may cycle on and off.

Electrical System

COMPONENT SPECIFICATIONS AND DIAGNOSTICS CONTROL BOARD

All QuietQube® control boards incorporate the following features. Refer to “Sequence of Operation” for additional information specific to your model.

Harvest/Safety Limit Light

This light's primary function is to be on as water contacts the ice thickness probe during the Freeze cycle, and remain on throughout the entire Harvest cycle. The light will flicker as water splashes on the probes. The light's secondary function is to continuously flash when the ice machine is shut off on a safety limit, and to indicate which safety limit shut off the ice machine.

Freeze Time Lock-In Feature

The ice machine control system incorporates a freeze time lock-in feature. This prevents the ice machine from short cycling in and out of Harvest.

The control board locks the ice machine in the Freeze cycle for six minutes. If water contacts the ice thickness probe during these six minutes, the Harvest light will come on (to indicate that water is in contact with the probe), but the ice machine will stay in the Freeze cycle. After the six minutes are up, a Harvest cycle is initiated.

To allow the service technician to initiate a Harvest cycle without delay, this feature is not used on the first cycle after moving the toggle switch OFF and back to ICE.

Maximum Freeze Time

The control system includes a built-in safety that will automatically cycle the ice machine into Harvest after 60 minutes in the Freeze cycle.

Safety Limits

There are two safety limits that protect the ice machine if the Freeze or Harvest cycles are outside of their guidelines.

Three-Minute Delay

The three-minute delay is initiated whenever the ice machine cycles off (automatic shut-off) on a full bin.

The delay period starts when a water curtain is open for 7 continuous seconds in the Harvest cycle.

- If the 3-minute delay period has expired, closure of the water curtain will initiate an immediate start-up of a Freeze sequence.
- If the water curtain closes before the 3-minute delay period has expired, the ice machine will start a Freeze sequence immediately after the 3-minute delay period expires.
- The 3-minute delay period is overridden when the toggle switch is moved to the OFF position, then back to ICE.

Inputs

The control board, along with inputs, controls all electrical components, including the ice machine sequence of operation. Prior to diagnosing, you must understand how the inputs affect the control board operation. Refer to specific component specifications (inputs), wiring diagrams and ice machine sequence of operation sections for details.

As an example, refer to “Ice Thickness Probe” in the component specification section of this manual for information relating to how the probe and control board function together.

Control Board Relays

The control board relays energize and de-energize system components.

Relays are not field replaceable.

MAIN FUSE

Function

The control board fuse stops ice machine operation if electrical components fail, causing high amp draw.

Specifications

The main fuse is 250 Volt, 7 amp.



Warning

High (line) voltage is applied to the control board (terminals #55 and #56) at all times. Removing the control board fuse or moving the toggle switch to OFF will not remove the power supplied to the control board.

Check Procedure

1. If the bin switch light is on with the water curtain closed, the fuse is good.



Warning

Disconnect electrical power to the entire ice machine before proceeding.

2. Remove the fuse. Check the resistance across the fuse with an ohmmeter.

Reading	Result
Open (OL)	Replace fuse
Closed (O)	Fuse is good

BIN SWITCH

Function

Movement of the water curtain controls bin switch operation. The bin switch has two main functions:

1. Terminating the Harvest cycle and returning the ice machine to the Freeze cycle. This occurs when the bin switch is opened and closed again within 7 seconds during the Harvest cycle.
2. Automatic ice machine shut-off.
If the storage bin is full at the end of a Harvest cycle, the sheet of cubes fails to clear the water curtain and holds it open. After the water curtain is held open for 7 seconds, the ice machine shuts off. The ice machine remains off until enough ice is removed from the storage bin to allow the sheet of cubes to drop clear of the water curtain. As the water curtain swings back to the operating position, the bin switch closes and the ice machine restarts, provide the 3-minute delay has expired.

Important

The water curtain must be ON (bin switch(s) closed) to start ice making.

Specifications

The bin switch is a magnetically operated reed switch. The magnet is attached to the lower right corner of the water curtain. The switch is attached to the evaporator-mounting bracket.

The bin switch is connected to a varying D.C. voltage circuit. (Voltage does not remain constant.)

NOTE: Because of a wide variation in D.C. voltage, it is not recommended that a voltmeter be used to check bin switch operation.

Check Procedure

1. Set the toggle switch to OFF.
2. Watch the bin switch light on the control board.
3. Move the water curtain toward the evaporator. The bin switch must close. The bin switch light “on” indicates the bin switch has closed properly.
4. Move the water curtain away from the evaporator. The bin switch must open. The bin switch light “off” indicates the bin switch has opened properly.

Ohm Test

1. Disconnect the bin switch wires to isolate the bin switch from the control board.
2. Connect an ohmmeter to the disconnected bin switch wires.
3. Cycle the bin switch by opening and closing the water curtain.

NOTE: To prevent misdiagnosis:

- Always use the water curtain magnet to cycle the switch. Larger or smaller magnets will affect switch operation.
- Watch for consistent readings when the bin switch is cycled open and closed. Bin switch failure could be erratic.

Water Curtain Removal Notes

The water curtain must be on (bin switch closed) to start ice making. While a Freeze cycle is in progress, the water curtain can be removed and installed at any time without interfering with the electrical control sequence.

If the ice machine goes into Harvest sequence while the water curtain is removed, one of the following will happen:

- **Water curtain remains off:**
When the Harvest cycle time reaches 3.5 minutes (QDUALC - 7 minutes) and the bin switch is not closed, the ice machine stops as though the bin were full.
- **Water curtain is put back on:**
If the bin switch closes prior to reaching the 3.5-minute point, the ice machine immediately returns to another Freeze sequence prechill.

ICE/OFF/CLEAN TOGGLE SWITCH

Function

The switch is used to place the ice machine in ICE, OFF or CLEAN mode of operation.

Specifications

Double-pole, double-throw switch. The switch is connected into a varying low D.C. voltage circuit.

Check Procedure

NOTE: Because of a wide variation in D.C. voltage, it is not recommended that a voltmeter be used to check toggle switch operation.

1. Inspect the toggle switch for correct wiring.
2. Isolate the toggle switch by disconnecting all wires from the switch, or by disconnecting the Molex connector and removing wire #69 from the toggle switch.
3. Check across the toggle switch terminals using a calibrated ohmmeter. Note where the wire numbers are connected to the switch terminals, or refer to the wiring diagram to take proper readings.

Switch Setting	Terminals		Ohm Reading
		QDUAL	
ICE	66-62	19-20	Open
	67-68	19-23	Closed
	67-69		Open
CLEAN	66-62	19-20	Closed
	67-68	19-23	Open
	67-69		Closed
OFF	66-62	19-20	Open
	67-68	19-23	Open
	67-69		Open

4. Replace the toggle switch if ohm readings do not match all three switch settings.

ICE THICKNESS PROBE (HARVEST INITIATION)

How the Probe Works

Manitowoc's electronic sensing circuit does not rely on refrigerant pressure, evaporator temperature, water levels or timers to produce consistent ice formation.

As ice forms on the evaporator, water (not ice) contacts the ice thickness probe. After the water completes this circuit across the probe continuously for 6-10 seconds, a Harvest cycle is initiated.

Ice Thickness Check

The ice thickness probe is factory-set to maintain the ice bridge thickness at 1/8 in. (3.2 mm).

NOTE: Make sure the water curtain is in place when performing this check. It prevents water from splashing out of the water trough.

1. Inspect the bridge connecting the cubes. It should be about 1/8 in. (3.2 mm) thick.
2. If adjustment is necessary, turn the ice thickness probe adjustment screw clockwise to increase bridge thickness or counterclockwise to decrease bridge thickness.

NOTE: Turning the adjustment 1/3 of a turn will change the ice thickness about 1/16 in. (1.5 mm). The starting point before final adjustment is approximately a 3/16 in. gap.

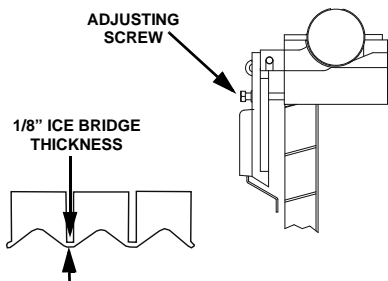

ICE THICKNESS ADJUSTMENT

SV3113

NOTE: Make sure the ice thickness probe wire and the bracket do not restrict movement of the probe.

Ice Thickness Probe Diagnostics

Before diagnosing ice thickness control circuitry clean the ice thickness probe using the following procedure.

1. Mix a solution of Manitowoc ice machine cleaner and water (2 ounces of cleaner to 16 ounces of water) in a container.
2. Soak ice thickness probe in container of cleaner/ water solution while disassembling and cleaning water circuit components (soak ice thickness probe for 10 minutes or longer).
3. Clean all ice thickness probe surfaces including all plastic parts (do not use abrasives). Verify the ice thickness probe cavity is clean. Thoroughly rinse ice thickness probe (including cavity) with clean water, then dry completely. **Incomplete rinsing and drying of the ice thickness probe can cause premature harvest.**
4. Reinstall ice thickness probe, then sanitize all ice machine and bin/dispenser interior surfaces.

Diagnosing Ice Thickness Control Circuitry

ICE MACHINE DOES NOT CYCLE INTO HARVEST WHEN WATER CONTACTS THE ICE THICKNESS CONTROL PROBE

Step 1. Bypass the freeze time lock-in feature by moving the ICE/OFF/CLEAN switch to OFF and back to ICE. Wait until the water starts to flow over the evaporator.

Step 2. Clip the jumper wire leads to the ice thickness probe and any cabinet ground.

Monitor the Harvest light.

Harvest Light On

- The Harvest light comes on, and 6-10 seconds later, the ice machine cycles from Freeze to Harvest.

The ice thickness control circuitry is functioning properly. Do not change any parts.

- The Harvest light comes on, but the ice machine stays in the Freeze sequence.

The ice thickness control circuitry is functioning properly. The ice machine is in a six-minute freeze time lock-in. Verify step 1 of this procedure was followed correctly.

Harvest Light Off

- The Harvest light does not come on.

Proceed to step 3.

Step 3. Disconnect the ice thickness probe from the control board at terminal 1C. Clip the jumper wire leads to terminal 1C on the control board and any cabinet ground.

Monitor the Harvest light.

Harvest Light On

- The harvest light comes on, and 6-10 seconds later, the ice machine cycles from Freeze to Harvest.

The ice thickness probe is causing the malfunction.

- The Harvest light comes on, but the ice machine stays in the Freeze sequence.

The control circuitry is functioning properly. The ice machine is in a six-minute freeze time lock-in (verify step 1 of this procedure was followed correctly).

Harvest Light Off

- The Harvest light does not come on.

The control board is causing the malfunction.

ICE MACHINE CYCLES INTO HARVEST BEFORE WATER CONTACT WITH THE ICE THICKNESS PROBE

Step 1. Disconnect the ice thickness probe from the control board at terminal 1C.

Step 2. Bypass the freeze time lock-in feature by moving the ICE/OFF/CLEAN switch to OFF and back to ICE. Wait until the water starts to flow over the evaporator, then monitor the Harvest light.

- The Harvest light stays off, and the ice machine remains in the Freeze sequence.

The ice thickness probe is causing the malfunction. Verify that the ice thickness probe is adjusted correctly.

- The Harvest light comes on, and 6-10 seconds later, the ice machine cycles from Freeze to Harvest.

The control board is causing the malfunction.

WATER LEVEL CONTROL CIRCUITRY

Q0600C/Q0800C/Q1000C/QDUAL Only

The water level probe circuit can be monitored by watching the water level light. The water level light is on when water contacts the probe, and off when no water is in contact with the probe. The water level light functions any time power is applied to the ice machine, regardless of toggle switch position.

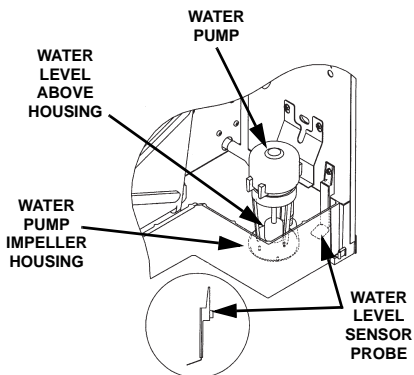

SV1616

FREEZE CYCLE WATER LEVEL SETTING

During the Freeze cycle, the water level probe is set to maintain the proper water level above the water pump housing. The water level is not adjustable. If the water level is incorrect, check the water level probe for damage (probe bent, etc.). Repair or replace the probe as necessary.

WATER INLET VALVE SAFETY SHUT-OFF

In the event of a water level probe failure, this feature limits the water inlet valve to a six-minute on time. Regardless of the water level probe input, the control board automatically shuts off the water inlet valve if it remains on for 6 continuous minutes. This is important to remember when performing diagnostic procedures on the water level control circuitry.

FREEZE CYCLE CIRCUITRY

Manitowoc's electronic sensing circuit does not rely on float switches or timers to maintain consistent water level control. During the Freeze cycle, the water inlet valve energizes (turns on) and de-energizes (turns off) in conjunction with the water level probe located in the water trough.

During the first 45 seconds of the Freeze cycle:

The water inlet valve is on when there is no water in contact with the water level probe.

- The water inlet valve turns off after water contacts the water level probe for 3 continuous seconds.
- The water inlet valve will cycle on and off as many times as needed to fill the water trough.

After 45 seconds into the Freeze cycle:

The water inlet valve will cycle on, and then off one more time to refill the water trough. The water inlet valve is now off for the duration of the Freeze sequence.

HARVEST CYCLE CIRCUITRY

The water level probe does not control the water inlet valve during the Harvest cycle. During the Harvest cycle water purge, the water inlet valve energizes (turns on) and de-energizes (turns off) strictly by time. The harvest water purge adjustment dial may be set at 15, 30 or 45 seconds.

NOTE: The water purge **must be at the factory setting** of 45 seconds for the water inlet valve to energize during the last 15 seconds of the water purge. If set at 15 or 30 seconds, the water inlet valve will not energize during the harvest water purge.

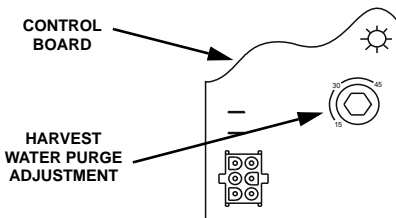

DIAGNOSING WATER LEVEL CONTROL CIRCUITRY

Q0600C/Q0800C/Q1000C/QDUAL Only

Problem: Water Trough Overfilling During the Freeze Cycle

Step 1. Start a new Freeze sequence by moving the ICE/OFF/CLEAN toggle switch to OFF and then back to ICE.

Important

This restart must be done prior to performing diagnostic procedures. This assures the ice machine is not in a Freeze cycle water inlet valve safety shut-off mode. You must complete the entire diagnostic procedure within 6 minutes of starting.

Step 2. Wait until the Freeze cycle starts (approximately 45 seconds – the Freeze cycle starts when the compressor energizes), then connect a jumper from the water level probe to any cabinet ground. Refer to the chart on the next page.

Important

For the test to work properly, you must wait until the Freeze cycle starts, prior to connecting the jumper wire. If you restart the test, you must disconnect the jumper wire, restart the ice machine (step 1), and then reinstall the jumper wire after the compressor starts.

**Step 2. Jumper Wire Connected
from Probe to Ground**

Is Water Flowing into the Water Trough?	The Water Level Light Is:	The Water Inlet Valve Solenoid Coil Is:	Cause
No	On	De-energized	This is normal operation. Do not change any parts.
Yes	On	De-energized	The water inlet valve is causing the problem.
Yes	Off	Energized	Proceed to step 3.

Step 3. Allow ice machine to run. Disconnect the water level probe from control board terminal 1F, and connect a jumper wire from terminal 1F to any cabinet ground.

Remember, if you are past 6 minutes from starting, the ice machine will go into a Freeze cycle water inlet valve safety shut-off mode, and you will be unable to complete this test. If past 6 minutes, you must restart this test by disconnecting the jumper wire, restarting the ice machine (step 1), and then reinstalling the jumper wire to terminal 1F after the compressor starts.

Step 3. Jumper Wire Connected from Control Board Terminal 1F to Ground			
Is Water Flowing into the Water Trough?	The Water Level Light Is:	The Water Inlet Valve Solenoid Coil Is:	Cause
No	On	De-energized	The water level probe is causing the problem. Clean or replace the water level probe.
Yes	Off	Energized	The control board is causing the problem.
Yes	Off	De-energized	The water fill valve is causing the problem.

Problem: Water Will Not Run into the Sump Trough During the Freeze Cycle

Q0600C/Q0800C/Q1000C/QDUAL Only

Step 1. Verify water is supplied to the ice machine, and then start a new Freeze sequence by moving the ICE/OFF/CLEAN toggle switch to OFF, then back to ICE.

Important

This restart must be done prior to performing diagnostic procedures. This assures the ice machine is not in a Freeze cycle water inlet valve safety shut-off mode. You must complete the entire diagnostic procedure within 6 minutes of starting.

Step 2. Wait until the Freeze cycle starts (approximately 45 seconds – the Freeze cycle starts when the compressor energizes), and then refer to the chart.

Step 2. Checking for Normal Operation

Is Water Flowing into the Water Trough?	The Water Level Light Is:	The Water Inlet Valve Solenoid Coil Is:	Cause
Yes	Off	Energized	This is normal operation. Do not change any parts.
No	On or Off	Energized or De-energized	Proceed to step 3.

Step 3. Leave the ice machine run, and then disconnect the water level probe from control board terminal 1F.

Important

For the test to work properly you must wait until the Freeze cycle starts, prior to disconnecting the water level probe. If you restart the test, you must reconnect the water level probe, restart the ice machine (step 1), and then disconnect the water level probe after the compressor starts.

Step 3. Disconnect Probe from 1F

Is Water Flowing into the Water Trough?	The Water Level Light Is:	The Water Inlet Valve Solenoid Coil Is:	Cause
Yes	Off	Energized	The water level probe is causing the problem. Clean or replace the water level probe.
No	Off	Energized	The water inlet valve is causing the problem.
No	On or Off	De-energized	The control board is causing the problem.

DIAGNOSING AN ICE MACHINE HEAD SECTION THAT WILL NOT RUN



Warning

High (line) voltage is applied to the control board at all times. Removing control board fuse or moving the toggle switch to OFF will not remove the power supplied to the control board.

If the water pump is energized but no ice is produced, refer to “Diagnosing a Condensing Unit that Will Not Run.”

1. Verify primary voltage is supplied to ice machine head section and the fuse/circuit breaker is closed.
2. Verify control board fuse is okay. If the bin switch or water level probe light functions, the fuse is okay.
3. Verify all bin switches function properly. A defective bin switch can falsely indicate a full bin of ice.
4. Verify ICE/OFF/CLEAN toggle switch functions properly. A defective toggle switch may keep the ice machine in the OFF mode.
5. Verify low DC voltage is properly grounded. Loose DC wire connections may intermittently stop the ice machine.
6. Replace the control board.

Be sure steps 1-5 were followed thoroughly. Intermittent problems are not usually related to the control board.

DIAGNOSING A CONDENSING UNIT THAT WILL NOT RUN

If the ice machine water pump is not energized, refer to “Diagnosing an Ice Machine Head Section that Will Not Run.”

1. Verify primary voltage is supplied to ice machine condensing unit and the fuse/circuit breaker is closed.
2. Verify the high-pressure cutout and low-pressure cutouts are closed. The HPCO and LPCO are closed if primary line voltage is present at the contactor coil terminals.
3. Verify line voltage is present at the contactor coil.
4. Verify the contactor contacts are closed and line voltage is present across all lines.
5. Refer to compressor diagnostics.

COMPRESSOR ELECTRICAL DIAGNOSTICS

The compressor does not start or will trip repeatedly on overload.

Check Resistance (Ohm) Values

NOTE: Compressor windings can have very low ohm values. Use a properly calibrated meter.

Perform the resistance test after the compressor cools. The compressor dome should be cool enough to touch (below 120°F/49°C) to assure that the overload is closed and the resistance readings will be accurate.

SINGLE PHASE COMPRESSORS

1. Disconnect power from the condensing unit and remove the wires from the compressor terminals.
2. The resistance values must be within published guidelines for the compressor. The resistance values between C and S and between C and R, when added together, should equal the resistance value between S and R.
3. If the overload is open, there will be a resistance reading between S and R, and open readings between C and S and between C and R. Allow the compressor to cool, then check the readings again.

THREE PHASE COMPRESSORS

1. Disconnect power from the condensing unit and remove the wires from the compressor terminals.
2. The resistance values must be within published guidelines for the compressor. The resistance values between L1 and L2, between L2 and L3, and between L3 and L1 should all be equal.
3. If the overload is open, there will be open readings between L1 and L2, between L2 and L3, and between L3 and L1. Allow the compressor to cool, then check the readings again.

CHECK MOTOR WINDINGS TO GROUND

Check continuity between all three terminals and the compressor shell or copper refrigeration line. Scrape metal surface to get good contact. If continuity is present, the compressor windings are grounded and the compressor should be replaced.

To determine if the compressor is seized, check the amp draw while the compressor is trying to start.

COMPRESSOR DRAWING LOCKED ROTOR

The two likely causes of this are a defective starting component and a mechanically seized compressor.

To determine which you have:

- Install high and low side gauges.
- Try to start the compressor.
- Watch the pressures closely.

If the pressures do not move, the compressor is seized. Replace the compressor.

If the pressures move, the compressor is turning slowly and is not seized. Check the capacitors and relay.

COMPRESSOR DRAWING HIGH AMPS

The continuous amperage draw on start-up should not be near the maximum fuse size indicated on the serial tag.

The wiring must be correctly sized to minimize voltage drop at compressor start-up. The voltage when the compressor is trying to start must be within $\pm 10\%$ of the nameplate voltage.

DIAGNOSING START COMPONENTS

If the compressor attempts to start, or hums and trips the overload protector, check the start components before replacing the compressor.

CAPACITOR

Visual evidence of capacitor failure can include a bulged terminal end or a ruptured membrane. Do not assume a capacitor is good if no visual evidence is present. A good test is to install a known good substitute capacitor. Use a capacitor tester when checking a suspect capacitor. Clip the bleed resistor off the capacitor terminals before testing.

RELAY

The relay has a set of contacts that connect and disconnect the start capacitor from the compressor start winding. The contacts on the relay are normally closed (start capacitor in series with the start winding). The relay senses the voltage generated by the start winding and opens the contacts as the compressor motor starts. The contacts remain open until the compressor is de-energized.



Warning

Disconnect electrical power to the condensing unit before proceeding.

Relay Operation Check

1. Disconnect wires from relay terminals.
2. Verify the contacts are closed. Measure the resistance between terminals 1 and 2. No continuity indicates open contacts. Replace the relay.
3. Check the relay coil. Measure the resistance between terminals 2 and 5. No resistance indicates an open coil. Replace the relay.

ELECTRICAL DIAGRAMS

Ice Machine Head Section

Q0600C/Q0800C/Q1000C

115V/60Hz/1Ph or 230V/50Hz/1Ph

(Diagram Shown in Freeze Cycle)

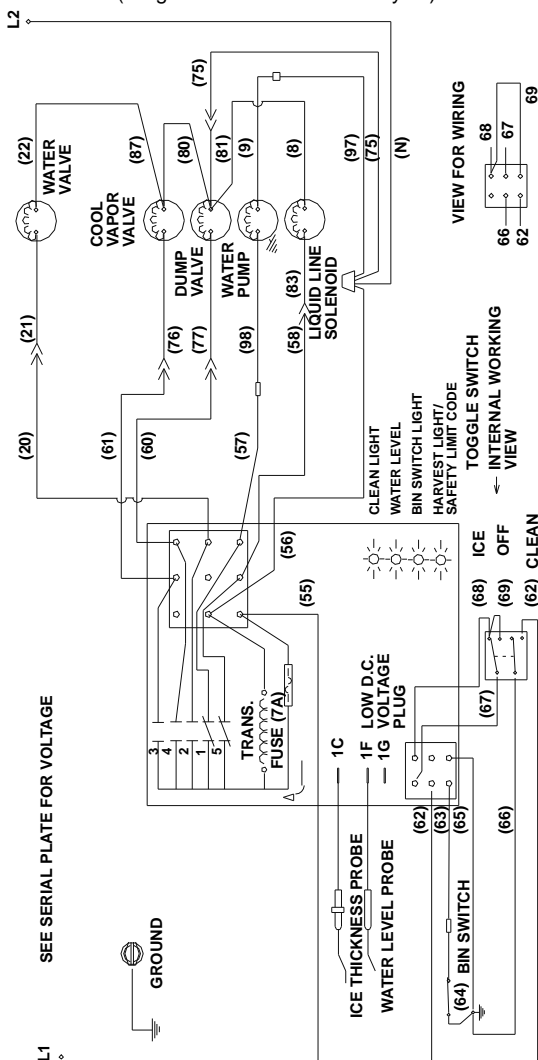

SU1000C

115V/60Hz/1Ph or 230V/50Hz/1Ph

(Diagram Shown in Freeze Cycle)

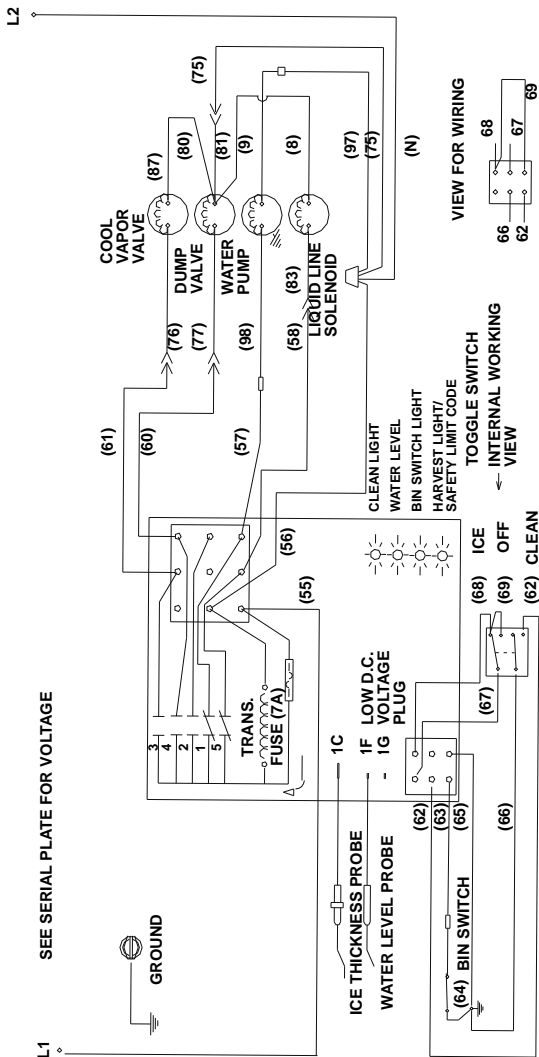

Q1400C

115V/60Hz/1Ph or 230V/50Hz/1Ph
(Diagram Shown in Freeze Cycle)

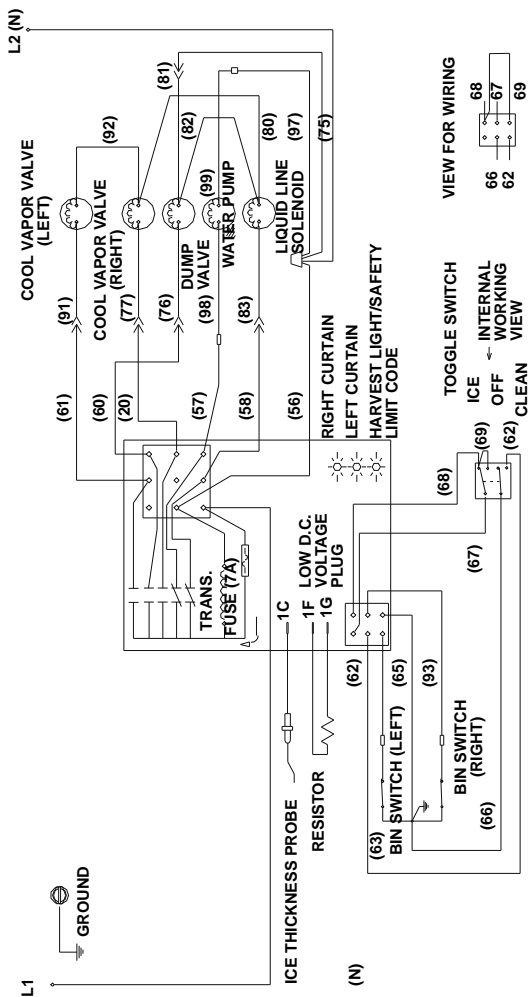

QDUALC

115V/60Hz/1Ph or 230V/50Hz/1Ph

(Diagram Shown in Freeze Cycle)

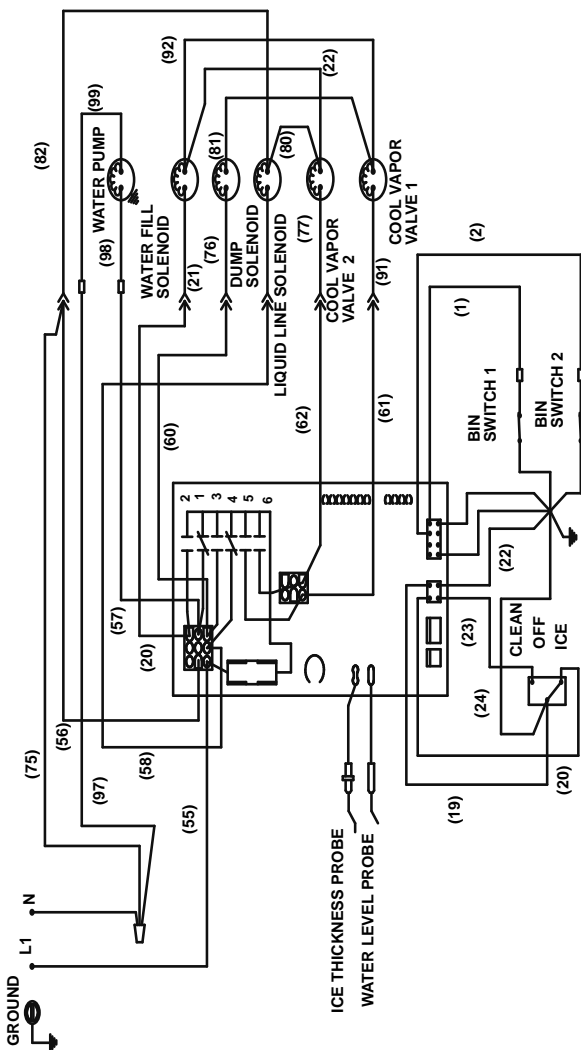

Condensing Unit

CVD0675/CVD0875/CVD1075/CVD1475/CVD1476/
CVD1875/CVD2075

208-230V/60Hz/1Ph or 230V/50Hz/1Ph

(Diagram Shown in Freeze Cycle)

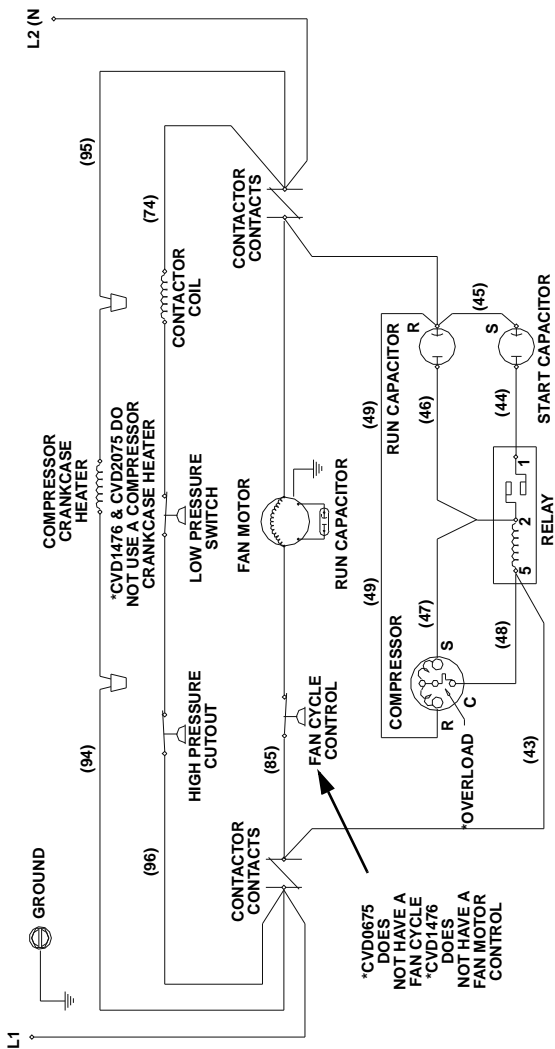

CVD0675/CVD0875/CVD1075/CVD1475/CVD1476/
 CVD1875/CVD2075
 208-230V/60Hz/3Ph
 (Diagram Shown in Freeze Cycle)

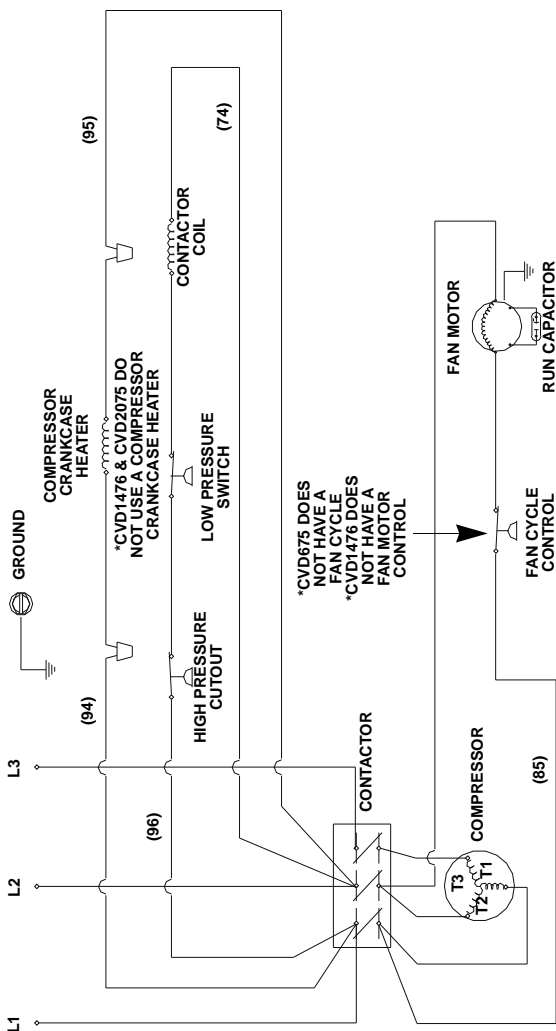

Refrigeration System

REFRIGERATION SYSTEM DIAGNOSTICS

General

Verify the water and electrical systems are functioning properly before diagnosing the refrigeration system or it's components.

A dirty evaporator increases the length of the harvest cycle and will cause the ice machine to shut off on safety limit #2. All Manitowoc Ice Machines must have their evaporator(s) cleaned first, if a safety limit #2 is in memory.

Refrigeration System Operation

FREEZE CYCLE

The compressor sends high pressure, high temperature gas to the condenser.

Air-Cooled Models - Discharge pressure will exceed the fan cycle control cut in set point and the condenser fan motor(s) energizes. The condenser removes heat and the refrigerant condenses to a high pressure liquid. The head pressure control valve will modulate to maintain the correct head pressure and refrigerant temperature.

Water-Cooled Models - The head pressure control valve modulates from the bypass position to the non-bypass position as the head pressure exceeds its set point. The condenser removes heat and the refrigerant condenses to a high pressure liquid. The water regulating valve will modulate to maintain the correct head pressure and refrigerant temperature.

The refrigerant enters the ice machine head section and is stored in the receiver. Liquid refrigerant leaves the receiver through a dip tube and passes through the line drier and liquid line solenoid valve. The refrigerant then passes through the heat exchanger where the liquid is sub-cooled before delivery to the TXV. The liquid refrigerant passes through the expansion valve orifice and enters the evaporator as a low pressure saturated vapor. As the refrigerant changes to an all vapor state, heat is absorbed from the evaporator. The

vapor refrigerant leaves the evaporator and passes through the heat exchanger absorbing additional heat from the liquid line. The suction vapor returns to the condensing unit, passes through the suction accumulator and enters the compressor.

HARVEST CYCLE

The head pressure control valve bypasses the condenser and sends compressor discharge gas directly to the receiver. The discharge gas keeps the receiver warm and the refrigerant pressure up as liquid refrigerant is boiled off the receiver. Vapor from the top of the receiver flows through the cool vapor valve and condenses in the evaporator. The change of state of the refrigerant from vapor to liquid releases the heat necessary for the harvest cycle. The refrigerant returns to the condensing unit and enters the suction accumulator. Vapor refrigerant is returned to the compressor.

SUCTION ACCUMULATOR OPERATION

Liquid refrigerant collects in the suction accumulator during the harvest cycle and is removed during the freeze cycle. The liquid refrigerant is returned to the compressor through a screen and orifice in the suction accumulator J tube. Passing the liquid through the orifice causes a pressure drop; the liquid flashes to a vapor and creates a refrigeration affect. It is normal to see frost on the accumulator, suction line and compressor suction port in the freeze cycle. The suction accumulator empties within the first 5 minutes of the freeze cycle. When the refrigeration affect ends (liquid refrigerant has been removed), the suction line between the accumulator and compressor will increase in temperature. The suction line temperature increases 20 plus degrees two minutes after the liquid has been removed. The time needed to remove the liquid refrigerant will vary with the ambient temperature and the length of the harvest cycle. Higher ambient temperatures = shorter harvest cycles, faster removal of liquid refrigerant from the accumulator and greater suction line temperature increases.

REFRIGERANT CHARGE

Refrigerant charge on QuietQube ice machines is very important. Overcharged or undercharged machines will normally fail in the harvest cycle (produces even sheets of ice, but will not harvest).

- Undercharged ice machines run out of liquid refrigerant in the receiver during harvest. This increases the harvest cycle time and results in a safety limit #2 failure.
- Overcharged ice machines sub cool the liquid refrigerant in the receiver during the freeze cycle, resulting in a refrigerant boil off rate in the harvest cycle that is too low. This increases the harvest cycle time and results in a safety limit #2 failure.
- When you are replacing refrigeration system components, verify refrigerant charge is correct by weighing amount recovered. Incorrect refrigerant charge will result in component misdiagnosis.

ICE MACHINE WILL NOT HARVEST DIAGNOSTICS

Ice release issues fall into two main categories mechanical or refrigeration. The first step in solving an ice release issue is to determine which condition exists. At the end of the harvest cycle place the toggle switch in the OFF position, then remove and inspect the sheet of ice.

- If the cubes are well defined and show no signs of melting a refrigeration problem is indicated.
- If the cubes are deformed and melted away (sharks teeth) a mechanical problem is indicated. Something on the evaporator is causing the harvest problem.
- Always clean the evaporator before diagnosing the refrigeration system.
- The water curtain must swing freely open and closed and the bin switch must function properly.

Refer to the checklist below, then specifications/diagnostics for individual components.

Harvest Cycle Diagnostic List

1. Suction, liquid line shut off valves and receiver service valve are fully open?
2. Line set properly sized?
3. Suction and liquid line sets are insulated?
4. Refrigerant charge is correct? (Overcharge or undercharge affects harvest cycle)
5. Headmaster operating correctly? (Check operation in freeze and harvest cycle)
6. Condenser fan shutting off during harvest cycle?
7. Cool vapor valve energized and open?
8. Liquid line kinked between condenser and ice machine head section?
9. TXV flooding during the freeze cycle?

ICE PRODUCTION CHECK

The amount of ice a machine produces directly relates to the operating water and air temperatures. This means a condensing unit with a 70°F (21.2°C) outdoor ambient temperature and 50°F (10.0°C) water produces more ice than the same model condensing unit with a 90°F (32.2°C) outdoor ambient temperature and 70°F (21.2°C) water.

1. Determine the ice machine operating conditions:

Air temp entering condenser: _____°

Air temp around ice machine: _____°

Water temp entering sump trough: _____°

2. Refer to the appropriate 24-Hour Ice Production Chart. Use the operating conditions determined in step 1 to find published 24-hour ice production: _____

• Times are in minutes.

Example: 1 min. 15 sec. converts to 1.25 min.
(15 seconds ÷ 60 seconds = .25 minutes)

• Weights are in pounds.

Example: 2 lb. 6 oz. converts to 2.375 lb.
(6 oz. ÷ 16 oz. = .375 lb.)

3. Perform an ice production check using the formula below.

1.	$\frac{\text{Freeze Time}}{\text{Freeze Time}}$	+	$\frac{\text{Harvest Time}}{\text{Harvest Time}}$	=	$\frac{\text{Total Cycle Time}}{\text{Total Cycle Time}}$
2.	$\frac{1440}{\text{Minutes in 24 Hrs.}}$	÷	$\frac{\text{Total Cycle Time}}{\text{Total Cycle Time}}$	=	$\frac{\text{Cycles per Day}}{\text{Cycles per Day}}$
3.	$\frac{\text{Weight of One Harvest}}{\text{Weight of One Harvest}}$	×	$\frac{\text{Cycles per Day}}{\text{Cycles per Day}}$	=	$\frac{\text{Actual 24-Hour Production}}{\text{Actual 24-Hour Production}}$

Weighing the ice is the only 100% accurate check. However, if the ice pattern is normal and the 1/8 in. thickness is maintained, the ice slab weights listed with the 24-Hour Ice Production Charts may be used.

1. Compare the results of step 3 with step 2. Ice production is normal when these numbers match closely. If they match closely, determine if:

- Another ice machine is required.
- More storage capacity is required.
- Relocating the existing equipment to lower the load conditions is required.

Contact the local Manitowoc Distributor for information on available options and accessories.

Installation/Visual Inspection Checklist

Possible Problem List

- Corrective Action List

Ice machine is not level

- Level the ice machine

Condenser is dirty

- Clean the condenser

Water filtration is plugged (if used)

- Install a new water filter

Water drains are not run separately and/or are not vented

- Run and vent drains according to the Installation Manual

Line set is improperly installed

- Reinstall according to the Installation Manual

Water System Checklist

A water-related problem often causes the same symptoms as a refrigeration system component malfunction.

Example: A water dump valve leaking during the Freeze cycle, a system low on charge, and a starving TXV have similar symptoms.

Water system problems must be identified and eliminated prior to replacing refrigeration components.

Possible Problem List

- Corrective Action List

Water area (evaporator) is dirty

- Clean as needed

Water inlet pressure not between 20 and 80 psig

- Install a water regulator valve or increase the water pressure

Incoming water temperature is not between 35°F (1.7°C) and 90°F (32.2°C)

- If too hot, check the hot water line check valves in other store equipment

Water filtration is plugged (if used)

- Install a new water filter

Water dump valve leaking during the Freeze cycle

- Clean/replace dump valve as needed

Vent tube is not installed on water outlet drain

- See Installation Instructions

Hoses, fittings, etc., are leaking water

- Repair/replace as needed

Water fill valve or float is stuck open or closed

- Clean/replace as needed

Water is spraying out of the sump trough area

- Stop the water spray

Uneven water flow across the evaporator

- Clean the ice machine

Water is freezing behind the evaporator

- Correct the water flow

Plastic extrusions and gaskets are not secured to the evaporator

- Remount/replace as needed

Ice Formation Pattern

Evaporator ice formation pattern analysis is helpful in ice machine diagnostics.

Analyzing the ice formation pattern alone cannot diagnose an ice machine malfunction. However, when this analysis is used along with Manitowoc's Refrigeration System Operational Analysis Table, it can help diagnose an ice machine malfunction.

Any number of problems can cause improper ice formation.

Example: An ice formation that is "extremely thin at evaporator outlet" could be caused by a hot water supply, a dump valve leaking water, a faulty water fill valve, a low refrigerant charge, etc.

Important

Keep the water curtain in place while checking the ice formation pattern to ensure no water is lost.

Evaporator Tubing Routing

Routing of the tubing on the back of the evaporator determines the ice fill pattern failure mode. The evaporator outlet tubing does not exit directly at the top of the evaporator, but exits several inches below the top of the evaporator. Extremely Thin at the Evaporator Outlet will first be visible several inches below the top of the evaporator. Extremely Thin at Evaporator Inlet will first be visible at the bottom of the evaporator.

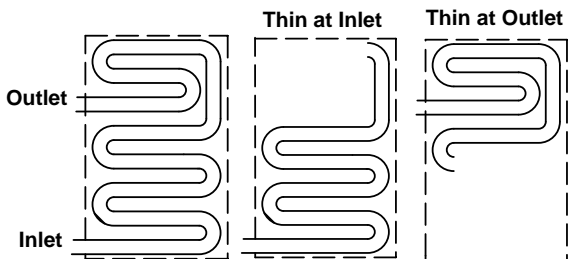

Ice Formation Patterns

1. Normal Ice Formation

Ice forms across the entire evaporator surface.

At the beginning of the Freeze cycle, it may appear that more ice is forming at the evaporator inlet, than on the evaporator outlet. At the end of the Freeze cycle, ice formation at the outlet will be close to, or just a bit thinner than, ice formation at the inlet. The dimples in the cubes at the outlet of the evaporator may be more pronounced than those at the inlet. This is normal.

The ice thickness probe must be set to maintain the ice bridge thickness at approximately 1/8 in. If ice forms uniformly across the evaporator surface, but does not reach 1/8 in. in the proper amount of time, this is still considered normal.

2. Extremely Thin at Evaporator Outlet

There is no ice, or a considerable lack of ice formation, at the evaporator outlet.

Examples: No ice at all at the evaporator outlet, but ice forms on the rest of the evaporator. Or, the ice at the evaporator outlet reaches 1/8 in. to initiate a harvest, but the rest of the evaporator already has 1/2 in. to 1 in. of ice formation.

Possible cause: Water loss, low on refrigerant, starving TXV, hot water supply, faulty water fill valve, etc.

3. Extremely Thin at Evaporator Inlet

There is no ice, or a considerable lack of ice formation on the evaporator inlet. Examples: The ice at the evaporator outlet reaches 1/8 in. to initiate a harvest, but there is no ice formation at all on the evaporator inlet.

Possible cause: Insufficient water flow, flooding TXV, etc.

4. Spotty Ice Formation

There are small sections on the evaporator where there is no ice formation. This could be a single corner or a single spot in the middle of the evaporator. Refer to Evaporator Tubing Routing on the previous page to determine your specific models tubing confirmation. This is generally caused by loss of heat transfer from the tubing on the backside of the evaporator.

5. No Ice Formation

The ice machine operates for an extended period, but there is no ice formation at all on the evaporator.

Possible cause: Water fill/float valve, water pump, starving expansion valve, low refrigerant charge, compressor, etc.

Important

Q1400C & QDUALC ice machines have left and right expansion valves and separate evaporator circuits. These circuits operate independently from each other. Therefore, one may operate properly while the other is malfunctioning.

Example: If the left expansion valve is starving, it may not affect the ice formation pattern on the right side of the evaporator.

Safety Limits

GENERAL

In addition to standard safety controls, such as the high-pressure cutout, the control board has two built-in safety limit controls which protect the ice machine from major component failures. There are two control boards with different safety limit sequences. The microprocessor chip can identify the control boards. Current production control boards have an orange label on the microprocessor with the number 302. The earlier version does not have the orange label.

Safety Limit #1: If the freeze time reaches 60 minutes, the control board automatically initiates a harvest cycle.

Control Board with orange label and 302 on microprocessor.

If six consecutive 60-minute freeze cycles occur, the ice machine stops.

Control Board with black microprocessor.

If three consecutive 60-minute Freeze cycles occur, the ice machine stops.

Safety Limit #2: If the harvest time reaches 3.5 minutes, the control board automatically returns the ice machine to the Freeze cycle.

Control board with orange label and 302 on microprocessor.

If 500 consecutive 3.5 minute harvest cycles occur, the ice machine stops.

Control board with black microprocessor.

If three consecutive 3.5-minute Harvest cycles occur, the ice machine stops.

Safety Limit Stand-By Mode: (QDUALC Only)

The first time a safety limit shut down occurs, (three consecutive long freeze or harvest cycles) the ice machine will turn off for 60 minutes (Stand-By Mode). During the Stand-By Mode the harvest light will be flashing continuously and a safety limit indication can be viewed. After 60 minutes the ice machine will automatically restart to see if the problem re-occurs. If the same safety limit is reached a second time (three more consecutive long freeze or harvest cycles) the ice machine will initiate a safety limit shut down and remain off until it is manually restarted. During a safety limit shut down the harvest light will be flashing continuously.

SAFETY LIMIT INDICATION

Control Board with Black Microprocessor

When a safety limit condition causes the ice machine to stop, the harvest light on the control board continually flashes on and off. Use the following procedures to determine which safety limit has stopped the ice machine.

1. Move the toggle switch to OFF.
2. Move the toggle switch back to ICE.
3. Watch the harvest light. It will flash one or two times, corresponding to safety limits 1 and 2, to indicate which safety limit stopped the ice machine.

After safety limit indication, the ice machine will restart and run until a safety limit is exceeded again.

Control Board with Orange Label and 302 on Microprocessor

When a safety limit condition is exceeded for 3 consecutive cycles the control board enters the limit to memory and the ice machine continues to run. Use the following procedure to determine if the control board contains a safety limit indication.

1. Move the toggle switch to OFF.
2. Move the toggle switch back to ICE.
3. Watch the harvest light. It will flash one or two times, corresponding to safety limits 1 and 2, to indicate which safety limit stopped the ice machine.

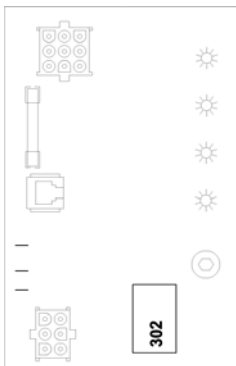

When a safety limit condition is exceeded (6 consecutive cycles for safety limit #1 or 500 cycles for safety limit #2) the ice machine stops, and the harvest light on the control board flashes on and off. Use the following procedure to determine which safety limit has stopped the ice machine.

1. Move the toggle switch to OFF.
2. Move the toggle switch back to ICE.
3. Watch the harvest light. It will flash one or two times, corresponding to safety limits 1 and 2, to indicate which safety limit stopped the ice machine.

After safety limit indication, the ice machine will restart and run until a safety limit is exceeded again.

SAFETY LIMIT NOTES

- Because there are many possible external problems, do not limit your diagnosis to only the items listed in these charts.
- A continuous run of 100 harvests automatically erases the safety limit code.
- The control board will store and indicate only one safety limit – the last one exceeded.
- If the toggle switch is moved to the OFF position and then back to the ICE position prior to reaching the 100-harvest point, the last safety limit exceeded will be indicated.
- If the Harvest light did not flash prior to the ice machine restarting, then the ice machine did not stop because it exceeded a safety limit.

SAFETY LIMIT CHECKLIST

The following checklists are designed to assist the service technician in analysis. However, because there are many possible external problems, do not limit your diagnosis to only the items listed.

Safety Limit #1

Refer to page 134 for description.

Possible Cause Checklist

Improper Installation

- Refer to “Installation/Visual Inspection Checklist”

Water System

- Low water pressure (20 psig min.)
- High water pressure (80 psig max.)
- High water temperature (90°F/32.2°C max.)
- Clogged water distribution tube
- Dirty/defective water fill valve
- Dirty/defective float valve
- Dirty/defective water dump valve
- Defective water pump
- Loss of water from sump area

Electrical System

- Ice thickness probe out of adjustment
- Harvest cycle not initiated electrically
- Contactor not energizing
- Compressor electrically non-operational
- High inlet air temperature (130°F/54.4°C max.)
- Condenser discharge air recirculation
- Defective fan cycling control
- Defective fan motor
- Restricted condenser air flow

Refrigeration System

- Non-Manitowoc components
- Improper refrigerant charge
- Defective head pressure control
- Defective cool vapor valve
- Defective compressor
- TXV starving or flooding (check bulb mounting)
- Non-condensable in refrigeration system
- Plugged or restricted high side refrigerant lines or component
- Restricted air flow/dirty condenser fins

Safety Limit #2

Refer to page 134 for description.

Possible Cause Checklist

Improper Installation

- Refer to “Installation/Visual Inspection Checklist”

Water System

- Water area (evaporator) dirty
- Dirty/defective water dump valve
- Vent tube not installed on water outlet drain
- Water freezing behind evaporator
- Plastic extrusions and gaskets not securely mounted to the evaporator
- Low water pressure (20 psig min.)
- Loss of water from sump area
- Clogged water distribution tube
- Dirty/defective water fill valve
- Dirty/defective float valve
- Defective water pump

Electrical System

- Ice thickness probe out of adjustment
- Ice thickness probe dirty
- Bin switch defective
- Premature harvest

Refrigeration System

- Non-Manitowoc components
- Improper refrigerant charge
- Defective head pressure control valve
- Defective cool vapor valve
- TXV flooding (check bulb mounting)
- Defective fan cycling control
(CVD0675/CVD1476 do not use a fan cycle control)
- CVD1476 Only - Water inlet valve is incorrectly adjusted or will not close during harvest cycle.

ANALYZING DISCHARGE PRESSURE

1. Determine the ice machine operating conditions:

Air temp. entering condenser _____

Air temp. around ice machine _____

Water temp. entering sump trough _____

2. Refer to Cycle Times/24-Hour Ice Production/ Refrigeration Pressure Chart for ice machine being checked.

Use the operating conditions determined in step 1 to find the published normal discharge pressures.

Freeze Cycle _____

Harvest Cycle _____

3. Perform an actual discharge pressure check.

	Freeze Cycle psig	Harvest Cycle psig
Beginning of Cycle	_____	_____
Middle of Cycle	_____	_____
End of Cycle	_____	_____

4. Compare the actual discharge pressure (step 3) with the published discharge pressure (step 2).

The discharge pressure is normal when the actual pressure falls within the published pressure range for the ice machine's operating conditions. It is normal for the discharge pressure to be higher at the beginning of the Freeze cycle (when load is greatest), then drop throughout the Freeze cycle.

Discharge Pressure High Checklist

Problem

- Cause

Improper Installation

- Refer to “Installation/Visual Inspection Checklist”

Condenser Restriction

- High inlet air temperature
- Condenser discharge air recirculation
- Dirty condenser fins
- Defective fan cycling control (CVD0675/CVD1476 does not use a fan cycle control)
- Defective fan motor

Improper Refrigerant Charge

- Overcharged
- Non-condensable in system
- Wrong type of refrigerant

Other

- Non-Manitowoc components in system
- High side refrigerant lines/component
- Restricted (before mid-condenser)
- Defective head pressure control valve
- Water Inlet Valve is incorrectly adjusted (CVD1476 only)

NOTE: Do not limit your diagnosis to only the items listed in the checklists.

Freeze Cycle Discharge Pressure Low Checklist

Problem

- Cause

Improper Installation

- Refer to “Installation/Visual Inspection Checklist”

Improper Refrigerant Charge

- Undercharged
- Wrong type of refrigerant

Other

- Non-Manitowoc components in system
- High side refrigerant lines/component restricted (before mid-condenser)
- Defective head pressure control valve
- Defective fan cycle control (Not used on CVD675/CVD1476)
- Water regulating valve incorrectly set (CVD1476 only)

NOTE: Do not limit your diagnosis to only the items listed in the checklists.

Analyzing Suction Pressure

The suction pressure gradually drops throughout the Freeze cycle. The actual suction pressure (and drop rate) changes as the air and water temperature entering the ice machine changes. These variables also determine the Freeze cycle times.

To analyze and identify the proper suction pressure drop throughout the Freeze cycle, compare the published suction pressure to the published Freeze cycle time.

NOTE: Analyze discharge pressure before analyzing suction pressure. High or low discharge pressure may be causing high or low suction pressure.

Procedure																						
Step	Example Using Q1000C Model Ice Machine																					
1. Determine the ice machine operating conditions.	Air temp. entering condenser: 90°F/32.2°C Air temp. around ice machine: 80°F/26.7°C Water temp. entering water fill valve: 70°F/21.1°C																					
2A. Refer to "Cycle Time" and "Operating Pressure" charts for ice machine model being checked. Using operating conditions from step 1, determine published Freeze cycle time and published Freeze cycle suction pressure.	<u>11.5-12.3 minutes</u> Published Freeze cycle time: <u>52-25 psig</u> Published Freeze cycle suction pressure:																					
2B. Compare the published Freeze cycle time and published Freeze cycle suction pressure. Develop a chart.	<p style="text-align: center;">Published Freeze Cycle Time (minutes)</p> <table style="margin: auto; border-collapse: collapse;"> <tr> <td style="text-align: center;">1</td> <td style="text-align: center;">2</td> <td style="text-align: center;">4</td> <td style="text-align: center;">6</td> <td style="text-align: center;">8</td> <td style="text-align: center;">10</td> <td style="text-align: center;">12</td> </tr> <tr> <td colspan="7" style="text-align: center;"> ----- ----- ----- ----- ----- ----- ----- </td> </tr> <tr> <td style="text-align: center;">52</td> <td style="text-align: center;">47</td> <td style="text-align: center;">43</td> <td style="text-align: center;">38</td> <td style="text-align: center;">34</td> <td style="text-align: center;">29</td> <td style="text-align: center;">25</td> </tr> </table> <p style="text-align: center;">Published Freeze Cycle Suction Pressure (psig)</p> <p>In the example, the proper suction pressure should be approximately 38 psig at 6 minutes; 34 psig at 8 minutes; etc.</p>	1	2	4	6	8	10	12	----- ----- ----- ----- ----- ----- -----							52	47	43	38	34	29	25
1	2	4	6	8	10	12																
----- ----- ----- ----- ----- ----- -----																						
52	47	43	38	34	29	25																
3. Perform an actual suction pressure check at the beginning, middle and end of the Freeze cycle. Note the times at which the readings are taken.	Manifold gauges were connected to the example ice machine and suction pressure readings taken as follows: psig Beginning of Freeze cycle: <u>59 (at 1 min.)</u> Middle of Freeze cycle: <u>48 (at 6 min.)</u> End of Freeze cycle: <u>40 (at 12 min.)</u>																					
4. Compare the actual Freeze cycle suction pressure (step 3) to the published Freeze cycle time and pressure comparison (step 2B). Determine if the suction pressure is high, low or acceptable.	In this example, the suction pressure is considered high throughout the Freeze cycle. It should have been: Approximately 52 psig (at 1 minute) – not 59 Approximately 38 psig (at 6 minutes) – not 48 Approximately 25 psig (at 12 minutes) – not 40																					

Suction Pressure High Checklist

Problem

- Cause

Improper Installation

- Refer to “Installation/Visual Inspection Checklist”

Discharge Pressure

- Discharge pressure is too high and is affecting suction pressure – refer to “Freeze Cycle Discharge Pressure High Checklist”

Improper Refrigerant Charge

- Overcharged
- Wrong type of refrigerant
- Non-condensable in system

Other

- Non-Manitowoc components in system
- Cool vapor valve leaking
- TXV flooding (check bulb mounting)
- Defective compressor

NOTE: Do not limit your diagnosis to only the items listed in the checklists.

Suction Pressure Low Checklist

Problem

- Cause

Improper Installation

- Refer to “Installation/Visual Inspection Checklist”

Discharge Pressure

- Discharge pressure is too low and is affecting suction pressure – refer to “Freeze Cycle Discharge Pressure Low Checklist”

Improper Refrigerant Charge

- Undercharged
- Wrong type of refrigerant

Other

- Non-Manitowoc components in system
- Improper water supply over evaporator – refer to “Water System Checklist”
- Loss of heat transfer from tubing on back side of evaporator
- Restricted/plugged liquid line drier
- Restricted/plugged tubing in suction side of refrigeration system
- TXV starving

NOTE: Do not limit your diagnosis to only the items listed in the checklists.

COOL VAPOR VALVE

The cool vapor valve is an electrically operated valve that opens when energized, and closes when de-energized.

Normal Operation

The valve is de-energized (closed) during the Freeze cycle and energized (open) during the Harvest cycle. The valve is positioned between the receiver and the evaporator and performs two functions:

1. Prevents refrigerant from entering the evaporator during the Freeze cycle.

The cool vapor valve is not used during the Freeze cycle. The cool vapor valve is de-energized (closed) preventing refrigerant flow from the receiver into the evaporator.

2. Allows refrigerant vapor to enter the evaporator in the Harvest cycle.

During the Harvest cycle, the cool vapor valve is energized (open), allowing refrigerant gas from the top of the receiver to flow into the evaporator. The refrigerant changes state (from a vapor to a liquid) and gives up latent heat. This heat is absorbed by the evaporator and allows release of the ice slab. In general, Harvest cycle suction pressure rises, then stabilizes in the range of 65-125 psig (448-861 kPa).

Exact pressures vary according to ambient temperature and ice machine model. Harvest pressures can be found in the "Cycle Time/24-Hour Ice Production/ Refrigerant Pressure Charts" in this book.

Cool Vapor Valve Analysis

The valve can fail in two positions:

- Valve will not open in the Harvest cycle.
- Valve remains open during the Freeze cycle.

Valve will not open in the Harvest cycle

Although the circuit board has initiated a Harvest cycle, suction and discharge pressures remain unchanged from the Freeze cycle. The ice machine will remain in the Harvest cycle for 3.5 minutes (7 minutes QDUAL), then initiate a new Freeze cycle. After three consecutive Harvest cycles of 3.5 minutes (7 minutes QDUAL) the ice machine will stop on a safety limit #2.

Valve remains open in the Freeze cycle

Symptoms of a cool vapor valve remaining partially open during the Freeze cycle can be similar to symptoms of an expansion valve, float valve or compressor problem. Symptoms are dependent on the amount of leakage in the Freeze cycle.

A small amount of leakage will cause increased freeze times and an ice fill pattern that is normal.

As the amount of leakage increases, the length of the Freeze cycle increases and the amount of ice on the bottom of the evaporator decreases.

A small amount of leakage will cause an audible indication as the vapor passes through the valve. As the size of the leak increases, the audible indication becomes more apparent.

Refer to the Parts Manual for proper valve application. If replacement is necessary, use only "original" Manitowoc replacement parts.

Freeze Cycle Suction Line Temperature Analysis

Suction line temperature alone cannot diagnose an ice machine. However, comparing this temperature during the Freeze cycle while using Manitowoc's Refrigeration Component Analysis Chart, will help diagnose an ice machine malfunction.

The actual temperature of the suction line varies by model and will change throughout the Freeze cycle. This makes documenting the "normal" suction line temperature difficult. The key to diagnosis is observing the suction line temperature during the last three minutes of the Freeze cycle.

Use this procedure to document Freeze cycle suction line temperatures.

1. Use a quality temperature meter, capable of taking temperature readings on curved copper lines.
2. Attach the temperature meter's thermocouple to the copper suction line within 6 in. of the suction shut-off valve.

Important

Do not simply insert the sensing device under the insulation. It must be attached to and reading the actual temperature of the copper line.

3. Monitor the suction line temperature during the last three minutes of the Freeze cycle and record the low event.
4. Use this with other information gathered on the Refrigeration Component Analysis Chart to determine the ice machine malfunction.
5. Verify refrigerant amount is correct by weight when recovering refrigerant and replacing a TXV. Grossly overcharged QuietQube ice machine in ambient temperatures below 70°F will have a suction line temperature below 10°F.

THIS PAGE INTENTIONALLY LEFT BLANK

REFRIGERATION COMPONENT DIAGNOSTIC CHARTS

General

All electrical and water-related problems must be corrected before these charts will work properly. These tables must be used with charts, checklists and other references to eliminate refrigeration components not listed and external items and problems that will cause good refrigeration components to appear defective.

The tables list four different defects that may affect the ice machine's operation.

Procedure

Step 1. Complete each item individually in the "Operational Analysis" column.

Enter check marks (✓) in the boxes.

Each time the actual findings of an item in the "Operational Analysis" column matches the published findings on the table, enter a check mark.

Example: Freeze cycle suction pressure is determined to be low. Enter a check mark in the "low" box.

Perform the procedures and check all information listed. Each item in this column has supporting reference material.

While analyzing each item separately, you may find an "external problem" causing a good refrigerant component to appear bad. **Correct problems as they are found. If the operational problem is found, it is not necessary to complete the remaining procedures.**

Step 2. Add the check marks listed under each of the four columns. Note the column number with the highest total and proceed to "Final Analysis."

NOTE: If two columns have matching high numbers, a procedure was not performed properly and/or supporting material was not analyzed correctly.

Final Analysis

The column with the highest number of check marks identifies the refrigeration problem.

Column 1 – Cool Vapor Valve Leaking

A leaking cool vapor valve must be replaced.

Column 2 – Low Charge/TXV Starving

Normally, a starving expansion valve only affects the Freeze cycle suction, discharge pressure and ice fill pattern. A low refrigerant charge will first affect the harvest cycle pressures. As more refrigerant is lost the freeze cycle pressures and fill pattern are affected. Verify the ice machine is not low on charge before replacing an expansion valve. Weigh the refrigerant when it is recovered and verify the amount recovered matches the ice machine model/serial plate amount.

Column 3 – TXV Flooding/Overcharge

A loose or improperly mounted expansion valve bulb causes the expansion valve to flood. Check bulb mounting, insulation, etc., before changing the valve. On dual expansion valve machines, the service technician should be able to tell which TXV is flooding by analyzing ice formation patterns. Change only the flooding expansion valve. Weigh the refrigerant when it is recovered and verify the amount recovered matches the ice machine model/serial plate amount.

Column 4 – Compressor

Replace the compressor and start components. To receive warranty credit, the compressor ports must be properly sealed by crimping and soldering them closed. Old start components must be returned with the faulty compressor.

REFRIGERATION COMPONENT DIAGNOSTIC CHARTS

Single Expansion Valve – Q0600C/0800C/Q1000C/SU1000C

Operational Analysis	1	2	3	4
Ice Production	Published 24-hour ice production _____ Calculated (actual) 24-hour ice production _____ NOTE: The ice machine is operating properly if the ice fill pattern is normal and ice production is within 10% of charted capacity.			
Installation and Water System	All installation and water-related problems must be corrected before proceeding with chart.			
Ice Formation Pattern	Ice formation is extremely thin on evaporator outlet or No ice formation on top of evaporator	Ice formation is extremely thin on evaporator outlet -or- No ice formation on entire evaporator	Ice formation normal -or- Ice formation is extremely thin at evaporator inlet or No ice formation on entire evaporator	Ice formation normal -or- No ice formation on entire evaporator

Single Expansion Valve – Q0600C/0800C/Q1000C/SU1000C (Continued)

Operational Analysis	1	2	3	4
<p>Safety Limits Refer to “Analyzing Safety Limits” to eliminate all non-refrigeration problems.</p>	<p>Stops on safety limit: 1 or 2</p>	<p>Stops on safety limit: 1 or 2</p>	<p>Stops on safety limit: 1 or 2</p>	<p>Stops on safety limit: 1</p>
<p>Freeze Cycle Discharge Pressure</p> <p style="text-align: center;"> </p>	<p>If discharge pressure is High or Low, refer to Freeze cycle high or low discharge pressure problem checklist to eliminate problems and/or components not listed on this table before proceeding.</p>			
<p>Freeze Cycle Suction Pressure</p> <p style="text-align: center;"> </p>	<p>If suction pressure is High or Low, refer to Freeze cycle high or low suction pressure problem checklist to eliminate problems and/or components not listed on this table before proceeding.</p>			
	<p>Suction pressure is High</p>	<p>Suction pressure is Low or Normal</p>	<p>Suction pressure is High or Normal</p>	<p>Suction pressure is High</p>

Single Expansion Valve – Q0600C/0800C/Q1000C/SU1000C (Continued)

Operational Analysis	1	2	3	4
Cool Vapor Valve	Audible refrigerant flow through valve in Freeze cycle	No audible refrigerant flow through valve in Freeze cycle	No audible refrigerant flow through valve in Freeze cycle	No audible refrigerant flow through valve in Freeze cycle
<p>Suction Line Temperature Attach a temperature probe on the suction line within 6 in. of the shut-off valve outlet. Record the low event at the end of the Freeze cycle.</p>	Suction line temperature at the suction shut-off valve is greater than 10°F (-12.2°C) at the end of the Freeze cycle.	Suction line temperature at the suction shut-off valve is greater than 10°F (-12.2°C) at the end of the Freeze cycle.	Suction line temperature at the suction shut-off valve is less than 10°F (-12.2°C) at the end of the Freeze cycle.	Suction line temperature at the suction shut-off valve is greater than 10°F (-12.2°C) at the end of the Freeze cycle.
<p>Final Analysis Enter total number of boxes checked in each column.</p>	Cool vapor valve leaking	Low on charge -or- TXV starving	Refrigerant Overcharge -or- TXV flooding	Compressor

Dual Expansion Valve – Q1400C/QDUAL

Operational Analysis	1	2	3	4
Ice Production	Published 24-hour ice production _____ Calculated (actual) 24-hour ice production _____ NOTE: The ice machine is operating properly if the ice fill pattern is normal and ice production is within 10% of charted capacity.			
Installation and Water System	All installation and water-related problems must be corrected before proceeding with chart.			
Ice Formation Pattern Left _____ Right _____	Ice formation is extremely thin on outlet of one evaporator -or- No ice formation on top of one evaporator	Ice formation is normal -or- Ice formation is extremely thin on outlet of one or both evaporators -or- No ice formation on one or both evaporators	Ice formation is normal -or- Ice formation is extremely thin on the inlet of one evaporator -or- No ice formation on one evaporator	Ice formation is normal -or- No ice formation on both evaporators

Dual Expansion Valve – Q1400C/QDUAL

Operational Analysis	1	2	3	4
<p style="text-align: center;">Safety Limits</p> <p style="text-align: center;">Refer to “Analyzing Safety Limits” to eliminate all non-refrigeration problems.</p>	<p>Stops on safety limit: 1 or 2</p>	<p>Stops on safety limit: 1 or 2</p>	<p>Stops on safety limit: 1 or 2</p>	<p>Stops on safety limit: 1</p>
<p style="text-align: center;">Freeze Cycle Discharge Pressure</p> <p style="text-align: center;">_____</p> <p style="text-align: center;">_____</p> <p style="text-align: center;">1 minute Middle End</p>	<p>If discharge pressure is High or Low, refer to Freeze cycle high or low discharge pressure problem checklist to eliminate problems and/or components not listed on this table before proceeding.</p>			
<p style="text-align: center;">Freeze Cycle Suction Pressure</p> <p style="text-align: center;">_____</p> <p style="text-align: center;">_____</p> <p style="text-align: center;">1 minute Middle End</p>	<p>If suction pressure is High or Low, refer to Freeze cycle high or low suction pressure problem checklist to eliminate problems and/or components not listed on this table before proceeding.</p>			
	<p>Suction pressure is High</p>	<p>Suction pressure is Low or Normal</p>	<p>Suction pressure is High or Normal</p>	<p>Suction pressure is High</p>

Dual Expansion Valve – Q1400C/QDUAL

Operational Analysis	1	2	3	4
Cool Vapor Valve	Audible refrigerant flow through left or right valve in Freeze cycle	No audible refrigerant flow through left or right valve in Freeze cycle	No audible refrigerant flow through left or right valve in Freeze cycle	No audible refrigerant flow through left or right valve in Freeze cycle
Suction Line Temperature Attach a temperature probe on the suction line within 6 in. of the shut-off valve outlet. Record the low event at the end of the Freeze cycle.	Suction line temperature at the suction shut-off valve is greater than 10°F (-12.2°C) at the end of the Freeze cycle	Suction line temperature at the suction shut-off valve is greater than 10°F (-12.2°C) at the end of the Freeze cycle	Suction line temperature at the suction shut-off valve is less than 10°F (-12.2°C) at the end of the Freeze cycle	Suction line temperature at the suction shut-off valve is greater than 10°F (-12.2°C) at the end of the Freeze cycle
Final Analysis Enter total number of boxes checked in each column.	Cool vapor valve leaking	Low on charge -or- TXV starving	Refrigerant Overcharge -or- TXV flooding	Compressor

PRESSURE CONTROL SPECIFICATIONS AND DIAGNOSTICS

Headmaster Control Valve

FUNCTION

The headmaster control valve maintains the correct discharge pressure and liquid line temperature in the Freeze and Harvest cycles.

Manitowoc QuietQube® systems require headmaster control valves with special settings. Replace defective headmaster control valves only with “original” Manitowoc replacement parts.

FREEZE CYCLE OPERATION

Air-Cooled Models

During low ambient conditions, it is normal for the head pressure control valve to hunt (head pressure may fluctuate up and down) on CVD condensing units. Hunting varies by model and ambient, but generally settles out within the first 6 minutes of the freeze cycle.

At ambient temperatures of approximately 70°F (21.1°C) or above, refrigerant flows through the valve from the condenser to the receiver inlet. At temperatures below this (or at higher temperatures if it is raining), the head pressure control starts to modulate (closes the condenser port and opens the bypass port from the compressor discharge line).

In this modulating mode, the valve maintains minimum head pressure by building up liquid in the condenser and bypassing discharge gas directly to the receiver.

Important

Head pressure settings will vary depending on the QuietQube® model being worked on.

Water-Cooled Models

The water regulating valve setting is higher than the head pressure control valve set point. All refrigerant is directed through the condenser and the water regulating valve maintains the correct head pressure.

HARVEST CYCLE OPERATION

During the Harvest cycle, the cool vapor valve opens and allows refrigerant from the top of the receiver tank to enter the evaporator. The refrigerants change of state (from vapor to liquid) releases the heat necessary for the Harvest cycle.

Opening the cool vapor valve causes a drop in discharge pressure.

Air-Cooled Models

The discharge pressure will drop below the condenser fan cycling control setpoint and the condenser fan motor cycles off (at ambient temperatures above 110°F (43°C) the condenser fan motor remains energized).

Water-Cooled Models

The head pressure control valve cycles into a complete bypass position (stopping all refrigerant flow through the condenser).

All CVD Models

The warm discharge gas adds heat to the receiver in the harvest cycle. Without this additional heat the head pressure would continue to drop as liquid refrigerant boils off in the receiver.

Example: A service technician removes refrigerant vapor from a cylinder by boiling off the liquid refrigerant. A refrigeration effect is created as the refrigerant changes state from a liquid to a vapor. The cylinder cools and the refrigerant pressure drops. To maximize flow and maintain pressure the technician places the cylinder in warm water.

A head pressure control valve that will not completely bypass in the harvest cycle will result in longer harvest cycles with lower than normal suction pressure and safety limit #2 trips.

(Refer to the “Cycle Times/24 Hr Ice Production/ Refrigerant Pressure Charts” for the model being worked on, to obtain the correct harvest cycle pressure range).

DIAGNOSING AIR-COOLED CONDENSING UNITS

Freeze Cycle

1. Determine the air temperature entering the remote condenser.
2. Determine if the head pressure is high or low in relationship to the outside temperature. (Refer to the proper “Operational Pressure Chart.”) If the air temperature is below 70°F (21.1°C), the head pressure control will modulate to maintain the correct liquid line temperature and head pressure.
3. Determine the temperature of the liquid line entering the receiver by feeling it. This line is normally warm – “body temperature.”
4. Using the information gathered, refer to the list for diagnosis.

NOTE: A headmaster that will not bypass will function properly with condenser air temperatures of approximately 70°F (21.1°C) or above. When the temperature drops below 70°F (21.1°C), the headmaster fails to bypass and the ice machine malfunctions. Rinsing the condenser with cool water during the Freeze cycle will simulate lower ambient conditions.

FREEZE CYCLE HEADMASTER CONTROL VALVE FAILURE LIST

CVD0875/CVD1075/CVD1475/CVD1875/CVD2075

Valve not maintaining pressures

- Non-approved valve. Install a Manitowoc head pressure control valve with proper setting.

Discharge pressure extremely high; liquid line entering receiver feels hot

- Valve stuck in bypass. Replace valve.

Fan cycling control cycles condenser fan motor; liquid line entering receiver fluctuates between warm and cold

- Valve not bypassing. Replace valve.

Discharge pressure low; liquid line entering receiver feels warm to hot

- Ice machine low on charge. Refer to “Low on Charge Verification.”

Fan cycling control cycles condenser fan motor; liquid line entering receiver feels warm to hot

- Ice machine low on charge. Refer to “Low on Charge Verification.”

CVD0675

Valve not maintaining pressures

- Non-approved valve. Install a Manitowoc head pressure control valve with proper setting.

Discharge pressure extremely high; liquid line entering receiver feels hot

- Valve stuck in bypass. Replace valve.

Discharge pressure low; liquid line entering receiver feels cold

- Valve not bypassing. Replace valve.

Discharge pressure low; liquid line entering receiver feels warm to hot

- Ice machine low on charge. Refer to “Low on Charge Verification.”

DIAGNOSING AIR-COOLED CONDENSING UNITS

Harvest Cycle

The headmaster control valve diverts the compressor discharge gas to the ice machine receiver in the harvest cycle. All refrigerant flow through the condenser in the harvest cycle stops. Symptoms of a headmaster valve that will not seat 100% closed (completely bypass the condenser) in the harvest cycle are:

- Freeze cycle suction and discharge pressure are normal.
- The control board indicates safety limit #2. The failure seems to be temperature related. Example: The ice machine may function correctly at temperatures above 32°F but fails at temperatures below 32°F.
- Harvest cycle suction pressure is low.
- Harvest cycle discharge pressure is normal or slightly low.

Procedure

1. Freeze cycle operation must be normal before diagnosing the headmaster in the harvest cycle. (Refer to Cycle Times/24 hr Ice Production/Refrigerant Pressure Chart)
2. Allow the ice machine to run a normal freeze cycle (do not initiate an early harvest cycle).
3. At the start of the harvest cycle feel the compressor discharge line and the liquid line to the ice machine receiver at the headmaster valve. The temperature of both lines will be highest at the beginning of the harvest cycle and then decrease. Compare the lines for the first 30 seconds of the harvest cycle and then refer to Harvest Cycle Headmaster Control Valve Failure List.

Step 3 Details
Grasp Here with Hands to Compare Temperatures

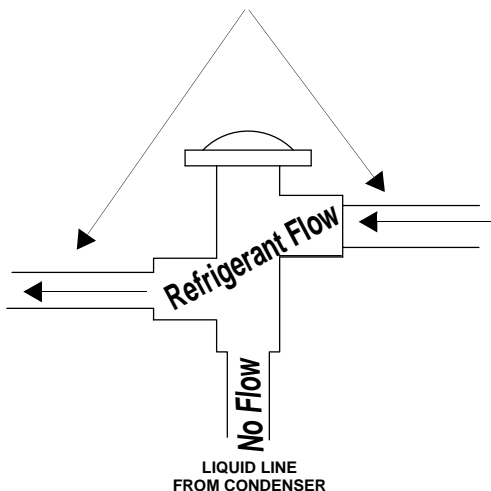

HARVEST CYCLE HEADMASTER CONTROL
VALVE FAILURE LIST
CVD675/CVD0875/CVD1075/CVD1475/CVD1476/
CVD1875/CVD2075

Temperature of the compressor discharge line and liquid line to the ice machine receiver feel the same for the first 30 seconds of the harvest cycle.

- The headmaster is functioning correctly.

The compressor discharge line is noticeably warmer than the liquid line to the ice machine receiver.

- Headmaster valve is not bypassing 100%. Replace headmaster valve.

DIAGNOSING WATER-COOLED CONDENSING UNIT HEADMASTER VALVE

Freeze Cycle

The water regulating valve maintains the freeze cycle discharge pressure. Refer to water regulating valve diagnostics.

Harvest Cycle

The headmaster control valve diverts the compressor discharge gas to the ice machine receiver in the harvest cycle. All refrigerant flow through the condenser in the harvest cycle stops. Symptoms of a headmaster valve that will not seat 100% closed in the harvest cycle (completely bypass the condenser) are:

- Freeze cycle suction and discharge pressure are normal.
- The control board indicates safety limit #2.
- Harvest cycle suction pressure is low.
- Harvest cycle discharge pressure is normal or high (water regulating valve attempts to maintain 240 psig)

HEADMASTER CONTROL VALVE FAILURE LIST CVD1476

Freeze Cycle

Valve not maintaining discharge pressure.

- The water regulating valve maintains the freeze cycle discharge pressure.

Discharge pressure extremely high; Liquid line entering receiver feels hot.

- Verify water regulating valve is set and/or operating correctly.
- Headmaster valve is stuck in bypass.

Discharge pressure low, Liquid line entering receiver feels warm to hot.

- Ice Machine low on charge. Refer to “Low on Charge Verification.”

Harvest Cycle

Discharge pressure normal or high, Liquid line entering receiver feels warm, suction pressure is low.

- Headmaster valve not bypassing. Refer to “Harvest Cycle Headmaster Control Valve Failure List” for diagnostic procedure.

REFRIGERANT CHARGE VERIFICATION

QuietQube remote ice machines require the correct amount of refrigerant (name plate charge) to operate correctly at all ambient conditions.

An ice machine with an over or under charge of refrigerant may function properly at higher ambient temperatures and fails at lower ambient temperatures. Symptoms of incorrect refrigerant are:

- Works during the day and then malfunctions at night.
- Safety limit #2 in control board memory.
- Harvest cycle suction pressure is low.

When refrigerant charge is suspected, verify by recovering the refrigerant, weighing and comparing to the nameplate amount. Refer to "Refrigerant Recovery/Evacuation" for recovery procedures.

Undercharge Symptoms

- Safety limit #2 in control board memory.
- Harvest cycle suction pressure is low.
- Harvest cycle discharge pressure is low.
- Liquid line entering receiver feels warm to hot in the freeze cycle.
- Depending on the amount of refrigerant loss, the ice machine may harvest for one or two cycles when restarted after an "Automatic Shut-off" (ice machine pumped down and shut off on low pressure control).

Overcharge Symptoms

- Safety limit #2 in control board memory.
- Harvest cycle suction pressure is low.
- Harvest cycle discharge pressure is normal.
- Freeze cycle time, suction and discharge pressure are normal and the ice machine will not harvest. The sheet of ice cubes show little or no sign of melting when removed from the evaporator after the harvest cycle has been completed. (If the cubes are melted you have a release problem, clean the ice machine).

Water Regulating Valve

Function

The water regulating valve maintains the freeze cycle discharge pressure. The valve setting for the CVD1476 condensing unit is 240 psig.

Check Procedure

1. Determine if the head pressure is high or low (refer to “Operational Pressure Chart”).
2. Verify the condenser water meets specifications.
3. Adjust valve to increase or decrease discharge pressure (if discharge pressure remains high refer to “Headmaster Control Valve Diagnostics” before replacing valve).
4. Determine the temperature of the liquid line entering the receiver by feeling it. This line is normally warm; “body temperature.”
5. Using the information gathered, refer to the list for diagnosis.

Problem (Freeze Cycle)

Valve not maintaining discharge pressure.

- Valve incorrectly set, dirty or defective. Adjust valve to 240 psig, clean or replace valve.

Discharge pressure extremely high; Liquid line entering receiver feels hot.

- Water regulating valve incorrectly set or not opening. Verify Head Pressure Control Valve operation before changing water regulating valve.

Discharge pressure low, Liquid line entering receiver feels warm to hot.

- Ice machine low on charge. Refer to “Refrigerant Charge Verification.”

Fan Cycle Control

CVD0875/CVD1075/CVD1475/CVD1875/CVD2075

FUNCTION

Energizes and de-energizes the condenser fan motor. The condenser fan motor typically will be on in the Freeze cycle and off in the Harvest cycle.

The fan cycle control closes on an increase, and opens on a decrease in discharge pressure.

Specifications		
Model	Cut-In (Close)	Cut-Out (Open)
CVD0875 CVD1075 CVD1475 CVD1875	250 psig \pm 5	200 psig \pm 5
CVD2075	250 psig \pm 5 275 psig \pm 5	200 psig \pm 5 225 psig \pm 5

CHECK PROCEDURE

1. Verify fan motor windings are not open or grounded, and fan spins freely.
2. Connect manifold gauges to ice machine.
3. Hook voltmeter in parallel across the fan cycle control, leaving wires attached.
4. Refer to chart below.

FCC Setpoint:	Reading Should Be:	Fan Should Be:
Above Cut-In	0 Volts	Running
Below Cut-Out	Line Voltage	Off

High Pressure Cutout (HPCO) Control

FUNCTION

Stops the ice machine if subjected to excessive high-side pressure.

The HPCO control is normally closed, and opens on a rise in discharge pressure.

Specifications	
Cut-Out	Cut-In
450 psig \pm 10	Automatic Reset
(Must be below 300 psig to reset.)	

CHECK PROCEDURE

1. Set ICE/OFF/CLEAN switch to OFF.
2. Disconnect power to condensing unit.
3. Connect manifold gauges on condensing unit access valves.
4. Hook voltmeter in parallel across the HPCO, leaving wires attached.
5. Reconnect condensing unit.
6. Set ICE/OFF/CLEAN switch to ICE, block condensing unit with cardboard or similar object.
7. No air flowing through the condenser will cause the HPCO control to open because of excessive pressure. Watch the pressure gauge and record the cut-out pressure.



Warning

If discharge pressure exceeds 460 psig and the HPCO control does not cut out, set ICE/OFF/CLEAN switch to OFF to stop ice machine operation.

Replace the HPCO control if it:

1. Will not reset (below 300 psig).
2. Does not open at the specified cut-out point.

Low Pressure Cutout (LPCO) Control

FUNCTION

Energizes and de-energizes the contactor coil when suction pressure rises above or falls below setpoint.

The LPCO control is closed at pressures above setpoint and opens at pressures below setpoint.

Specifications	
Cut-Out	Cut-In
7 psig \pm 3	22 psig \pm 3

CHECK PROCEDURE

1. Connect manifold gauges at suction and discharge access valves at the condensing unit.
2. Set ICE/OFF/CLEAN switch to OFF.
3. The liquid line solenoid valve will de-energize and the suction pressure will begin to decrease. The low-pressure control will open at the listed specification.
4. Use the manifold gauge set to increase suction pressure. Feed refrigerant from the high side access valve to the low side access valve. Add refrigerant in small increments to allow the low side pressure to be monitored. The low pressure control will close at the listed specification.

Replace the LPCO control if it:

1. Will not close at the specified setpoint.
2. Does not open at the specified setpoint.

QUIETQUBE® TUBING SCHEMATICS

Q0600C/Q0800C/Q1000C

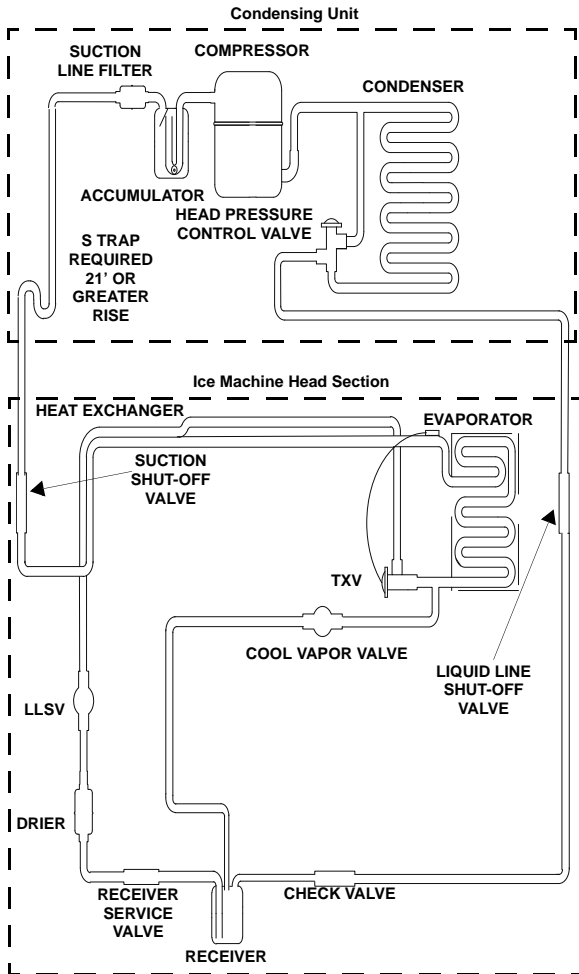

Q1400C/QDUALC

Condensing Unit

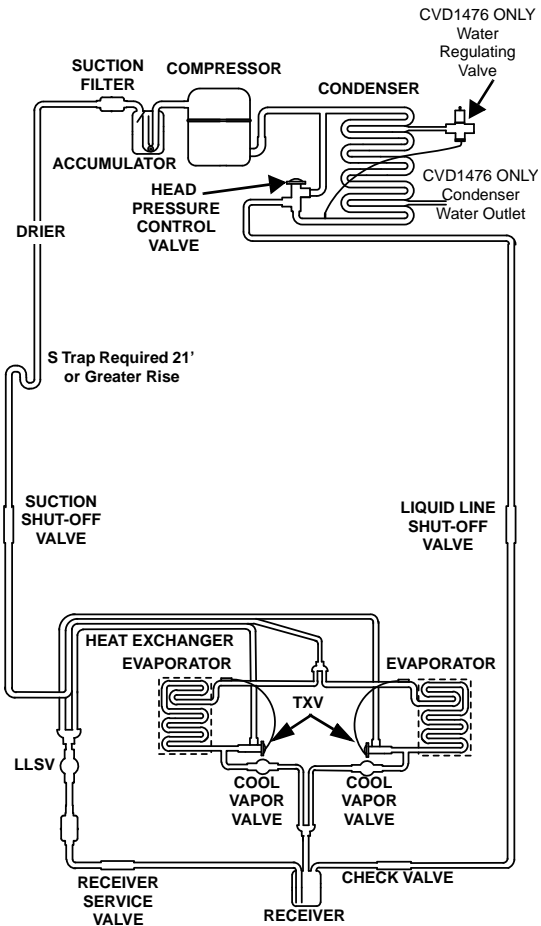

Cycle Times/24-Hour Ice Production/ Refrigerant Pressure Charts

These charts are used as guidelines to verify correct ice machine operation.

Accurate collection of data is essential to obtain the correct diagnosis.

- Refer to “OPERATIONAL ANALYSIS CHART” for the list of data that must be collected for refrigeration diagnostics. This list includes: before beginning service, ice production check, installation/visual inspection, water system checklist, ice formation pattern, safety limits, comparing evaporator inlet/outlet temperatures, cool vapor valve analysis, discharge and suction pressure analysis.
- Ice production checks that are within 10% of the chart are considered normal. This is due to variances in water and air temperature. Actual temperatures will seldom match the chart exactly.
- Zero out manifold gauge set before obtaining pressure readings to avoid misdiagnosis.
- All pressure readings are taken at the ice machine head section. Connect Manifold gauge set at the suction and liquid line shut-off valves to obtain pressure readings. Pressures taken at the condensing unit will vary with line set length, ambient, exposed line set etc. and will not match the published pressures. Do not use the receiver service valve to obtain high side pressures.
- Discharge and suction pressure are highest at the beginning of the cycle. Suction pressure will drop throughout the cycle. Verify the pressures are within the range indicated.
- During low ambient conditions, it is normal for the head pressure control valve to hunt (fluctuate up and down) on CVD condensing units. Hunting varies by model and ambient temperature, but generally settles out within the first 6 minutes of the freeze cycle.

Q0600C/CVD675 SERIES REMOTE AIR COOLED

NOTE: These characteristics may vary depending on operating conditions.

CYCLE TIMES

Freeze Time + Harvest Time = Cycle Time				
Air Temp. Entering Condenser °F/°C	Freeze Time			Harvest Time
	Water Temperature °F/°C			
	50/10.0	70/21.1	90/32.2	
-20 to 70/ -29 to 21.1	7.8-9.3	8.8-10.4	9.5-11.2	.75-2.5
80/26.7	8.0-9.4	8.9-10.5	9.7-11.4	
90/32.2	8.6-10.2	9.8-11.5	10.6-12.5	
100/37.8	9.7-11.4	11.0-12.9	12.0-14.0	
¹ Times in minutes.				

24-HOUR ICE PRODUCTION

Air Temp. Entering Condenser °F/°C	Water Temperature °F/°C		
	50/10.0	70/21.1	90/32.2
-20 to 70/ -29 to 21.1	635	575	540
80/26.7	625	570	530
90/32.2	585	525	490
100/37.8	530	475	440
¹ Based on average ice slab weight of 4.12-4.75 lb.			
² Regular cube derate is 7%.			

OPERATING PRESSURES

Air Temp. Entering Condenser °F/°C	Freeze Cycle		Harvest Cycle	
	Discharge Pressure psig	Suction Pressure psig	Discharge Pressure psig	Suction Pressure psig
-20 to 50/ -29 to 10.0	260-215	46-26	140-185	70-95
70/21.1	270-220	51-26	150-190	70-100
80/26.7	285-225	56-27	155-195	80-105
90/32.2	295-235	59-28	165-200	85-105
100/37.8	340-260	60-30	180-210	85-112
110/43.3	385-300	65-34	195-230	90-120
Refer to page 176.				

Q0800C/CVD875 SERIES REMOTE AIR COOLED

NOTE: These characteristics may vary depending on operating conditions.

CYCLE TIMES

Freeze Time + Harvest Time = Cycle Time				
Air Temp. Entering Condenser °F/°C	Freeze Time			Harvest Time
	Water Temperature °F/°C			
	50/10.0	70/21.1	90/32.2	
-20 to 70/ -29 to 21.1	9.4-10.8	10.5-12.1	11.4-13.1	.75-2.5
80/26.7	9.5-11.0	10.7-12.3	11.4-13.1	
90/32.2	10.3-11.9	11.2-12.9	12.1-13.8	
100/37.8	11.2-12.9	12.3-14.1	13.3-15.2	

¹Times in minutes.

24-HOUR ICE PRODUCTION

Air Temp. Entering Condenser °F/°C	Water Temperature °F/°C		
	50/10.0	70/21.1	90/32.2
-20 to 70/ -29 to 21.1	760	690	640
80/26.7	750	680	640
90/32.2	700	650	610
100/37.8	650	600	560

¹Based on average ice slab weight of 5.75-6.50 lb.
²Regular cube derate is 7%.

OPERATING PRESSURES

Air Temp. Entering Condenser °F/°C	Freeze Cycle		Harvest Cycle	
	Discharge Pressure psig	Suction Pressure psig	Discharge Pressure psig	Suction Pressure psig
-20 to 50/ -29 to 10.0	260-215	46-22	140-185	70-95
70/21.1	270-220	40-23	150-190	70-100
80/26.7	285-225	47-24	155-195	80-95
90/32.2	295-235	52-25	165-200	85-100
100/37.8	340-260	56-26	180-210	85-112
110/43.3	385-300	60-28	195-230	90-115

Refer to page 176.

Q1000C/CVD1075 SERIES REMOTE AIR COOLED

NOTE: These characteristics may vary depending on operating conditions.

CYCLE TIMES

Freeze Time + Harvest Time = Cycle Time				
Air Temp. Entering Condenser °F/°C	Freeze Time			Harvest Time
	Water Temperature °F/°C			
	50/10.0	70/21.1	90/32.2	
-20 to 70/ -29 to 21.1	9.9-10.6	10.8-11.6	11.8-12.6	.75-2.5
80/26.7	10.1-10.9	10.9-11.7	12.1-13.0	
90/32.2	10.6-11.4	11.5-12.3	12.8-13.7	
100/37.8	11.6-12.5	12.6-13.5	14.0-15.0	
¹ Times in minutes.				

24-HOUR ICE PRODUCTION

Air Temp. Entering Condenser °F/°C	Water Temperature °F/°C		
	50/10.0	70/21.1	90/32.2
-20 to 70/ -29 to 21.1	980	910	840
80/26.7	960	900	820
90/32.2	920	860	780
100/37.8	850	790	720
¹ Based on average ice slab weight of 7.75-8.25 lb.			
² Regular cube derate is 7%.			

OPERATING PRESSURES

Air Temp. Entering Condenser °F/°C	Freeze Cycle		Harvest Cycle	
	Discharge Pressure psig	Suction Pressure psig	Discharge Pressure psig	Suction Pressure psig
-20 to 50/ -29 to 10.0	260-215	40-22	140-185	70-95
70/21.1	270-220	42-24	150-190	80-95
80/26.7	275-225	48-24	155-195	85-95
90/32.2	275-235	52-25	165-195	85-100
100/37.8	325-260	55-25	180-205	85-112
110/43.3	360-300	60-27	195-225	95-118
Refer to page 176.				

SU1000C/SERVEND UC-300 DISPENSER/CVD1075 REMOTE AIR COOLED

NOTE: These characteristics may vary depending on operating conditions.

CYCLE TIMES

Freeze Time + Harvest Time = Cycle Time				
Air Temp. Entering Condenser °F/°C	Freeze Time			Harvest Time
	Water Temperature °F/°C			
	50/10.0	70/21.1	90/32.2	
-20 to 70/ -29 to 21.1	9.9-10.6	10.8-11.6	11.8-12.6	.75-2.5
80/26.7	10.1-10.9	10.9-11.7	12.1-13.0	
90/32.2	10.6-11.4	11.5-12.3	12.8-13.7	
100/37.8	11.6-12.5	12.6-13.5	14.0-15.0	

¹Times in minutes.

24-HOUR ICE PRODUCTION

Air Temp. Entering Condenser °F/°C	Water Temperature °F/°C		
	50/10.0	70/21.1	90/32.2
-20 to 70/ -29 to 21.1	980	910	840
80/26.7	960	900	820
90/32.2	920	860	780
100/37.8	850	790	720

¹Based on average ice slab weight of 7.75-8.25 lb.

OPERATING PRESSURES

Air Temp. Entering Condenser °F/°C	Freeze Cycle		Harvest Cycle	
	Discharge Pressure psig	Suction Pressure psig	Discharge Pressure psig	Suction Pressure psig
-20 to 50/ -29 to 10.0	260-215	40-22	140-185	70-95
70/21.1	270-220	42-24	150-190	80-95
80/26.7	275-225	48-24	155-195	85-95
90/32.2	275-235	52-25	165-195	85-100
100/37.8	325-260	55-25	180-205	85-112
110/43.3	360-300	60-27	195-225	95-118

Refer to page 176.

Q1400C/CVD1475 SERIES REMOTE AIR COOLED

NOTE: These characteristics may vary depending on operating conditions.

CYCLE TIMES

Freeze Time + Harvest Time = Cycle Time				
Air Temp. Entering Condenser °F/°C	Freeze Time			Harvest Time
	Water Temperature °F/°C			
	50/10.0	70/21.1	90/32.2	
-20 to 70/ -29 to 21.1	11.1-12.6	12.6-14.4	14.4-16.4	.75-2.5
90/32.2	11.3-12.9	12.9-14.7	14.8-16.8	
100/37.8	12.2-13.9	14.1-16.0	16.1-18.3	
110/43.3	13.5-15.4	15.8-17.9	16.3-18.5	

¹Times in minutes.

24-HOUR ICE PRODUCTION

Air Temp. Entering Condenser °F/°C	Water Temperature °F/°C		
	50/10.0	70/21.1	90/32.2
-20 to 70/ -29 to 21.1	1375	1225	1085
90/32.2	1350	1200	1060
100/37.8	1260	1110	980
110/43.3	1150	1000	970

¹Based on average ice weight of one Harvest cycle
12.00-13.50 lb. (6.00-6.75 lb. per evaporator).

OPERATING PRESSURES

Air Temp. Entering Condenser °F/°C	Freeze Cycle		Harvest Cycle	
	Discharge Pressure psig	Suction Pressure psig	Discharge Pressure psig	Suction Pressure psig
-20 to 50/ -29 to 10.0	260-215	42-22	140-185	70-95
70/21.1	275-220	42-24	150-190	70-95
80/26.7	285-225	43-25	155-195	85-95
90/32.2	290-235	44-26	160-195	85-100
100/37.8	335-260	46-28	170-200	85-115
110/43.3	385-310	50-30	180-210	95-125

Refer to page 176.

Q1400C/CVD1476 REMOTE WATER COOLED

NOTE: These characteristics may vary depending on operating conditions.

CYCLE TIMES

Freeze Time + Harvest Time = Cycle Time				
Air Temp. Entering Condenser °F/°C	Freeze Time			Harvest Time
	Water Temperature °F/°C			
	50/10.0	70/21.1	90/32.2	
35 to 70/ 1.6 to 21.1	10.7-12.7	12.4-14.7	14.6-17.3	.75-2.5
80/26.7	10.8-12.9	12.5-14.9	14.7-17.4	
90/32.2	10.9-13.0	12.6-15.0	14.8-17.5	
100/37.8	10.9-13.0	12.7-15.0	14.9-17.6	

¹Times in minutes.

24-HOUR ICE PRODUCTION

Air Temp. Entering Condenser °F/°C	Water Temperature °F/°C		
	50/10.0	70/21.1	90/32.2
35 to 70/ 1.6 to 21.1	1420	1245	1070
80/26.7	1400	1230	1065
90/32.2	1395	1225	1060
100/37.8	1390	1220	1055

¹Based on average ice weight of one Harvest cycle 12.00-14.00 lb. (6.00-7.00 lb. per evaporator).

OPERATING PRESSURES

Air Temp. Entering Condenser °F/°C	Freeze Cycle		Harvest Cycle	
	Discharge Pressure psig	Suction Pressure psig	Discharge Pressure psig	Suction Pressure psig
35 to 70/ 1.6 to 21.0	265-235	48-28	150-170	70-90
80/26.7	265-235	48-28	150-170	70-90
90/32.2	265-235	48-28	150-170	70-90
100/37.8	270-235	49-29	160-180	70-90
110/43.3	275-235	50-30	160-180	75-95

Refer to page 176.

CONDENSER WATER CONSUMPTION

Condenser Water Consumption	90/32.2 Air Temperature Around Ice Machine		
	Water Temp. °F/°C		
	50/10.0	70/21.1	90/32.2
Gal/24 Hours	1200	2100	4000

QDUAL/CVD1875 REMOTE AIR COOLED

NOTE: These characteristics may vary depending on operating conditions.

CYCLE TIMES

Freeze Time + Harvest Time = Cycle Time				
Air Temp. Entering Condenser °F/°C	Freeze Time			Harvest Time
	Water Temperature °F/°C			
	50/10.0	70/21.1	90/32.2	
-20 to 70/ -29 to 21.1	10.8-11.6	11.9-12.7	12.8-13.7	.75-2.5
90/32.2	12.0-12.9	13.1-14.0	14.2-15.2	
100/37.8	13.1-14.0	14.3-15.4	15.7-16.8	
110/43.3	14.9-16.0	16.2-17.4	17.4-18.6	

¹Times in minutes.

24-HOUR ICE PRODUCTION

Air Temp. Entering Condenser °F/°C	Water Temperature °F/°C		
	50/10.0	70/21.1	90/32.2
-20 to 70/ -29 to 21.1	1820	1670	1560
80/26.7	1650	1530	1420
90/32.2	1530	1410	1300
100/37.8	1360	1260	1180

¹Based on average ice weight of one Harvest cycle
15.50-16.50 lb.
²Regular cube derate is 7%.

OPERATING PRESSURES

Air Temp. Entering Condenser °F/°C	Freeze Cycle		Harvest Cycle	
	Discharge Pressure psig	Suction Pressure psig	Discharge Pressure psig	Suction Pressure psig
-20 to 50/ -29 to 10.0	260-215	42-22	140-185	65-85
70/21.1	275-220	42-24	150-190	70-90
80/26.7	285-250	43-25	155-195	70-95
90/32.2	310-265	44-26	165-195	70-100
100/37.8	370-300	46-28	170-200	85-115
110/43.3	395-335	50-30	180-210	90-125

Refer to page 176

QDUAL/CVD2075 REMOTE AIR COOLED

NOTE: A Scroll compressor must be operated for a minimum break-in period of 72 hours before full ice production will be reached. These characteristics may vary depending on operating conditions.

CYCLE TIMES

Freeze Time + Harvest Time = Cycle Time				
Air Temp. Entering Condenser °F/°C	Freeze Time			Harvest Time
	Water Temperature °F/°C			
	50/10.0	70/21.1	90/32.2	
-20 to 70/ -29 to 21.1	9.7-10.4	10.9-11.7	11.6-12.5	1.5-6.0
90/32.2	10.1-10.8	11.3-12.1	12.0-12.9	.75-2.5
100/37.8	10.8-11.6	12.0-12.9	12.9-13.8	
110/43.3	12.0-12.9	12.5-13.4	13.9-14.9	

¹Times in minutes.

24-HOUR ICE PRODUCTION

Air Temp. Entering Condenser °F/°C	Water Temperature °F/°C		
	50/10.0	70/21.1	90/32.2
-20 to 70/ -29 to 21.1	2000	1800	1700
80/26.7	1930	1750	1650
90/32.2	1810	1650	1550
100/37.8	1650	1590	1450

¹Based on average ice weight of one Harvest cycle
15.50-16.50 lb.
²Regular cube derate is 7%.

OPERATING PRESSURES

Air Temp. Entering Condenser °F/°C	Freeze Cycle		Harvest Cycle	
	Discharge Pressure psig	Suction Pressure psig	Discharge Pressure psig	Suction Pressure psig
-20 to 50/ -29 to 10.0	260-215	38-15	130-175	50-70
70/21.1	270-220	42-16	140-185	65-85
80/26.7	280-250	45-17	160-205	65-85
90/32.2	290-255	48-17	180-210	70-85
100/37.8	320-265	52-18	180-215	75-90
110/43.3	360-300	55-19	185-220	85-100

Refer to page 176.

Refrigerant Recovery/Evacuation

Do not purge refrigerant to the atmosphere. Capture refrigerant using recovery equipment. Follow the manufacturer's recommendations.

Important

Manitowoc Ice, Inc. assumes no responsibility for the use of contaminated refrigerant. Damage resulting from the use of contaminated refrigerant is the sole responsibility of the servicing company.

Important

Replace the liquid line drier before evacuating and recharging. Use only a Manitowoc (OEM) liquid line filter-drier to prevent voiding the warranty.

CONNECTIONS

Manifold gauge sets must utilize low loss fittings to comply with U.S. Government rules and regulations. Make these connections:

- Suction side of the compressor through the suction shut-off valve.
- Discharge side of the compressor through the liquid line shut-off valve.
- Receiver service valve, which evacuates the area between the check valve in the liquid line and the liquid line solenoid valve.



Warning

Recovery/evacuation of a QuietQube® remote system requires connections at three points for complete system recovery/evacuation. A check valve is located in the ice machine head section between the liquid line shut-off valve and the receiver. The check valve prevents refrigerant migration from the receiver to the condensing unit in the Off cycle. Connections must be made at three points (receiver service valve, suction line and liquid line) to allow recovery and evacuation of the entire system.

Warning

The receiver service valve (located in the ice machine head section) must be accessed during refrigerant recovery to allow complete removal of the refrigerant charge.

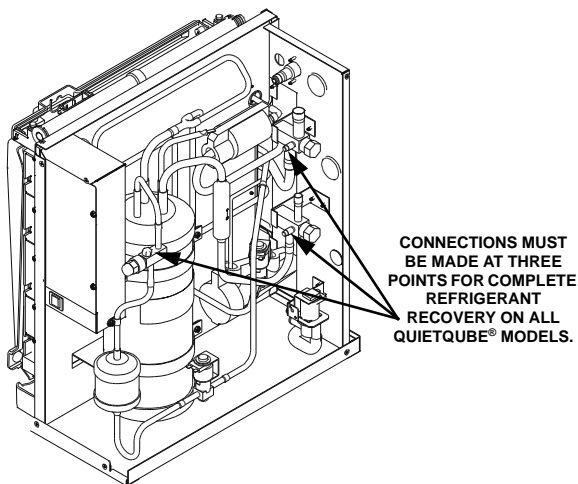

REFRIGERANT RECOVERY CONNECTIONS (Q1400C SHOWN)

RECOVERY/EVACUATION PROCEDURES

1. Place the ICE/OFF/CLEAN toggle switch in the OFF position and disconnect all power to the ice machine and condensing unit.
2. Install manifold gauges, charging scale, and recovery unit or two-stage vacuum pump.
3. Open the receiver service valve halfway.
4. Open high and low side on the manifold gauge set.
5. Perform recovery or evacuation:
 - A. Recovery: Operate the recovery unit as directed by the manufacturer's instructions.
 - B. Evacuation prior to recharging: Evacuate to 250 microns. Then allow the pump to run for an additional hour. Turn off the pump and perform a standing vacuum leak check.
6. Refer to Charging Procedures.

CHARGING PROCEDURES

1. Verify the ICE/OFF/CLEAN toggle switch is in the OFF position.
2. Close the vacuum pump valve and the low side manifold gauge valve.
3. Open the refrigerant cylinder and add the proper refrigerant charge (shown on nameplate) into the system high side (receiver service valve and discharge line shut-off valve).
4. If the high side does not take the entire charge, close the high side on the manifold gauge set. Start the ice machine and add the remaining charge through valves on back of ice making head, or through valves on suction filter, not through low side service port on condenser, as it connects directly into compressor. Compressor damage can result.
5. Ensure all refrigerant in the charging hoses is drawn into the low side of the system, then disconnect the manifold gauges.
6. Run the ice machine in the Freeze cycle.
7. Close the receiver service valve in the ice machine head section.
8. Disconnect the manifold gauge set from the liquid line shut-off valve.
9. Open the high and low side valves on the manifold gauge set. Any refrigerant in the lines will be pulled into the low side of the system.
10. Allow the pressures to equalize while the ice machine is in the Freeze cycle.
11. Disconnect the manifold gauge set from the suction line shut-off valve.
12. Install and torque all valve caps

NOTE: Check for refrigerant leaks after all valve caps have been installed.

SYSTEM CONTAMINATION CLEANUP

General

This section describes the basic requirements for restoring contaminated systems to reliable service.

Important

Manitowoc Ice, Inc. assumes no responsibility for the use of contaminated refrigerant. Damage resulting from the use of contaminated refrigerant is the sole responsibility of the servicing company.

Determining Severity of Contamination

System contamination is generally caused by either moisture or residue from compressor burnout entering the refrigeration system.

Inspection of the refrigerant usually provides the first indication of system contamination. Obvious moisture or an acrid odor in the refrigerant indicates contamination.

If either condition is found, or if contamination is suspected, use a Total Test Kit from Totaline or a similar diagnostic tool. These devices sample refrigerant, eliminating the need to take an oil sample. Follow the manufacturer's directions.

If a refrigerant test kit indicates harmful levels of contamination, or if a test kit is not available, inspect the compressor oil.

1. Remove the refrigerant charge from the ice machine.
2. Remove the compressor from the system.
3. Check the odor and appearance of the oil.
4. Inspect open suction and discharge lines at the compressor for burnout deposits.
5. If no signs of contamination are present, perform an acid oil test to determine the type of cleanup required.

NOTE: Manitowoc Service procedures require re-use of the refrigerant if the quality has not been compromised.

Contamination Cleanup Chart	
Symptoms/Findings	Required Cleanup Procedure
No symptoms or suspicion of contamination	Normal evacuation/recharging procedure
Moisture/Air Contamination symptoms <ul style="list-style-type: none"> • Refrigeration system open to atmosphere for longer than 15 minutes • Refrigeration test kit and/or acid oil test shows contamination • No burnout deposits in open compressor lines 	Mild contamination cleanup procedure
Mild Compressor Burnout symptoms <ul style="list-style-type: none"> • Oil appears clean but smells acrid • Refrigeration test kit or acid oil test shows harmful acid content • No burnout deposits in open compressor lines 	Severe contamination cleanup procedure
Severe Compressor Burnout symptoms <ul style="list-style-type: none"> • Oil is discolored, acidic, and smells acrid • Burnout deposits found in the compressor, lines, and other components 	Severe contamination cleanup procedure

Cleanup Procedure

MILD SYSTEM CONTAMINATION

1. Replace any failed components.
2. If the compressor is good, change the oil.
3. Replace the liquid line drier and suction filter.

NOTE: If the contamination is from moisture, use heat lamps during evacuation. Position them at the compressor, condenser and evaporator prior to evacuation. Do not position heat lamps too close to plastic components, or they may melt or warp.

Important

Dry nitrogen is recommended for this procedure. This will prevent CFC release.

4. Follow the normal evacuation procedure, except replace the evacuation step with the following:
 - A. Pull vacuum to 1000 microns. Break the vacuum with dry nitrogen and sweep the system. Pressurize to a minimum of 5 psig.
 - B. Pull vacuum to 500 microns. Break the vacuum with dry nitrogen and sweep the system. Pressurize to a minimum of 5 psig.
 - C. Change the vacuum pump oil.
 - D. Pull vacuum to 250 microns. Run the vacuum pump for 1/2 hour on self-contained models, 1 hour on remotes.

NOTE: You may perform a pressure test as a preliminary leak check. You should use an electronic leak detector after system charging to be sure there are no leaks.

5. Charge the system with the proper refrigerant to the nameplate charge.
6. Operate the ice machine.

SEVERE SYSTEM CONTAMINATION

1. Remove the refrigerant charge.
2. Remove the compressor.
3. Cut copper tubing at the outlet of the cool vapor valve. If burnout deposits are found inside the tubing, replace the cool vapor valve, TXV and head pressure control valve.
4. Wipe away any burnout deposits from suction and discharge lines at compressor.
5. Sweep through the open system with dry nitrogen.

Important

Refrigerant sweeps are not recommended, as they release CFCs into the atmosphere.

6. Install a new compressor and new start components.
7. Replace existing suction line filter-drier in front of accumulator.
8. Install a new liquid line drier.

Important

Dry nitrogen is recommended for this procedure.
This will prevent CFC release.

9. Follow the normal evacuation procedure, except replace the evacuation step with the following:
 - A. Pull vacuum to 1000 microns. Break the vacuum with dry nitrogen and sweep the system. Pressurize to a minimum of 5 psig.
 - B. Change the vacuum pump oil.
 - C. Pull vacuum to 500 microns. Break the vacuum with dry nitrogen and sweep the system. Pressurize to a minimum of 5 psig.
 - D. Change the vacuum pump oil.
 - E. Pull vacuum to 250 microns. Run the vacuum pump for 1 hour additional.
10. Charge the system with the proper refrigerant to the nameplate charge.
11. Operate the ice machine for one hour. Then, check the pressure drop across the suction line filter-drier.
 - A. If the pressure drop is less than 2 psig, the filter-drier should be adequate for complete cleanup.
 - B. If the pressure drop exceeds 2 psig, change the suction line filter-drier and the liquid line drier. Repeat until the pressure drop is acceptable.
12. Operate the ice machine for 48-72 hours. Then replace the suction line drier and change the liquid line drier.
13. Follow normal evacuation procedures.

REPLACING PRESSURE CONTROLS WITHOUT REMOVING REFRIGERANT CHARGE

This procedure reduces repair time and cost. Use it when any of the following components require replacement, and the refrigeration system is operational and leak-free.

- Fan cycle control
- High pressure cut-out control
- Low pressure cut-out control
- High side condensing unit access valve
- Low side condensing unit access valve
- Water regulating valve

Important

This is a required in-warranty repair procedure.

1. Disconnect power to the ice machine.
2. Follow all manufacturer's instructions supplied with the pinch-off tool. Position the pinch-off tool around the tubing as far from the pressure control as feasible. (See the figure on next page.) Clamp down on the tubing until the pinch-off is complete.



Warning

Do not unsolder a defective component. Cut it out of the system. Do not remove the pinch-off tool until the new component is securely in place.

3. Cut the tubing of the defective component with a small tubing cutter.
4. Solder the replacement component in place. Allow the solder joint to cool.
5. Remove the pinch-off tool.
6. Re-round the tubing. Position the flattened tubing in the proper hole in the pinch-off tool. Tighten the wing nuts until the block is tight and the tubing is rounded.

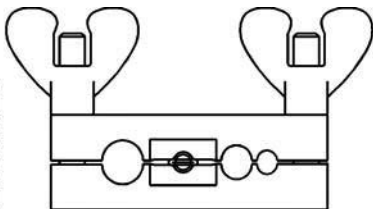

FIG. A - "PINCHING OFF" TUBING

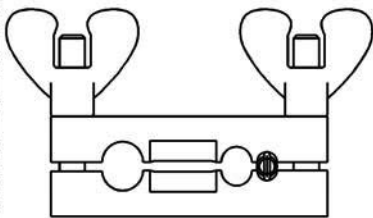

FIG. B - RE-ROUNDING TUBING

USING PINCH-OFF TOOL

SV1406

NOTE: The pressure controls will operate normally once the tubing is re-rounded. Tubing may not re-round 100%.

FILTER-DRIERS

Liquid Line Filter-Drier

The filter-driers used on Manitowoc ice machines are manufactured to Manitowoc specifications.

The difference between a Manitowoc drier and an off-the-shelf drier is in filtration. A Manitowoc drier has dirt-retaining filtration, with fiberglass filters on both the inlet and outlet ends. This is very important because ice machines have a back-flushing action that takes place during every Harvest cycle.

A Manitowoc filter-drier has a very high moisture removal capability and a good acid removal capacity.

Listed below is the recommended OEM field replacement drier:

Liquid Line Driers			
Model	Drier Size	End Connection Size	Part Number
Q0600C Q0800C Q1000C SU1000C	UK-082S	1/4 in.	89-3024-3
Q1400C	UK-083S	3/8 in.	89-3027-3
QDUAL	UK-163S	3/8 in.	82-5816-3

Important

The liquid line drier is covered as a warranty part. The liquid line drier must be replaced any time the system is opened for repair.

Suction Line Filter

The suction filter traps particulate only and does not contain a desiccant. The filter needs replacement when:

1. The pressure drop across the drier exceeds 2 psig.
2. The total system refrigerant charge has escaped and the refrigeration system has been exposed to the atmosphere.
3. A compressor is replaced.
4. Refrigeration system contains contaminants.

Listed below is the recommended OEM field replacement filter:

Suction Line Filter			
Model	Drier Size	End Connection Size	Part Number
CVD0675 CVD0875	ASF35S5	5/8 in.	82-5030-3
CVD1075 CVD1475 CVD1476	ASF45S6	3/4 in.	82-5026-3
CVD1875 CVD2075	ASF45S7	7/8 in.	82-5027-3

TOTAL SYSTEM REFRIGERANT CHARGE

Important

This information is for reference only. Refer to the ice machine serial number tag to verify the system charge. Serial plate information overrides information listed on this page.

Model	Condensing Unit	Refrigerant Charge (lbs. / oz.)	Line Set Length
Q0600C	CVD675	11 lbs. 76 oz.	0-100 ft.
Q0800C	CVD875	12 lbs. 192 oz.	0-100 ft.
		11 lbs. 176 oz.	0-100 ft.
Q1000C	CVD1075	12 lbs. 192 oz.	0-100 ft.
SU1000C SerVend UC300 Dispenser			
Q1400C	CVD1475 CVD1476	12.5 lbs. 192 oz.	0-100 ft.
QDUAL	CVD1875 CVD2075	19 lbs. 304 oz.	0-50 ft.

NOTE: All ice machines on this list are charged using R-404A refrigerant.

Total charge listed is for line set lengths up to 100 ft.

QDUAL Only:

For line set lengths over 50 ft., add 1 lb. of refrigerant for each additional 10 ft. of tubing.

REFRIGERANT OIL

Manitowoc QuietQube ice machines use POE oil.

The recommended lubricant is Mobil EAL22A.

Refrigeration systems exposed to atmosphere for more than 5 minutes must have the compressor oil changed. The compressor must be removed and at least 95% of the oil must be removed through the suction port of the compressor. Measure the oil as it is removed and replace with the same amount of new oil.

REFRIGERANT DEFINITIONS

RECOVER

To remove refrigerant, in any condition, from a system and store it in an external container, without necessarily testing or processing it in any way.

RECYCLE

To clean refrigerant for reuse by oil separation and single or multiple passes through devices, such as replaceable core filter-driers, which reduce moisture, acidity and particulate matter. This term usually applies to procedures implemented at the field job site or at a local service shop.

RECLAIM

To reprocess refrigerant to new product specifications (see below) by means which may include distillation. A chemical analysis of the refrigerant is required after processing to be sure that product specifications are met. This term usually implies the use of processes and procedures available only at a reprocessing or manufacturing facility.

Chemical analysis is the key requirement in this definition. Regardless of the purity levels reached by a reprocessing method, refrigerant is not considered “reclaimed” unless it has been chemically analyzed and meets ARI Standard 700 (latest edition).

NEW PRODUCT SPECIFICATIONS

This means ARI Standard 700 (latest edition). Chemical analysis is required to assure that this standard is met.

REFRIGERANT REUSE POLICY

Manitowoc recognizes and supports the need for proper handling, reuse, and disposal of CFC and HCFC refrigerants. Manitowoc service procedures require recapturing refrigerants, not venting them to the atmosphere.

It is not necessary, in or out of warranty, to reduce or compromise the quality and reliability of your customers' products to achieve this.

Important

Manitowoc Ice, Inc. assumes no responsibility for use of contaminated refrigerant. Damage resulting from the use of contaminated, recovered, or recycled refrigerant is the sole responsibility of the servicing company.

Manitowoc approves the use of:

1. New Refrigerant

- Must be of original nameplate type.

2. Reclaimed Refrigerant

- Must be of original nameplate type.
- Must meet ARI Standard 700 (latest edition) specifications.

3. Recovered or Recycled Refrigerant

- Must be recovered or recycled in accordance with current local, state and federal laws.
- Must be recovered from and reused in the same Manitowoc product. Reuse of recovered or recycled refrigerant from other products is not approved.
- Recycling equipment must be certified to ARI Standard 740 (latest edition) and be maintained to consistently meet this standard.
- Recovered refrigerant must come from a “contaminant-free” system. To decide whether the system is contaminant-free, consider:
 - Type(s) of previous failure(s)
 - Whether the system was cleaned, evacuated and recharged properly following failure(s)
 - Whether the system has been contaminated by this failure
- Compressor motor burnouts and improper past service prevent refrigerant reuse.
- Refer to “System Contamination Cleanup” to test for contamination.

4. “Substitute” or “Alternative” Refrigerant

- Must use only Manitowoc-approved alternative refrigerants.
- Must follow Manitowoc-published conversion procedures.

MANITOWOC ICE

2110 South 26th Street P.O. Box 1720

Manitowoc, WI 54221-1720 USA

Phone: 920-682-0161 Fax: 920-683-7585

Website – www.manitowocice.com

©2003 Manitowoc Ice

Litho in U.S.A.