



Manitowoc[®]

Q Model QuietQube[®] Ice Machines with CVD[®] Technology

Models Q1400C

**Installation
and
Owner/Operator
Use and Care Manual**

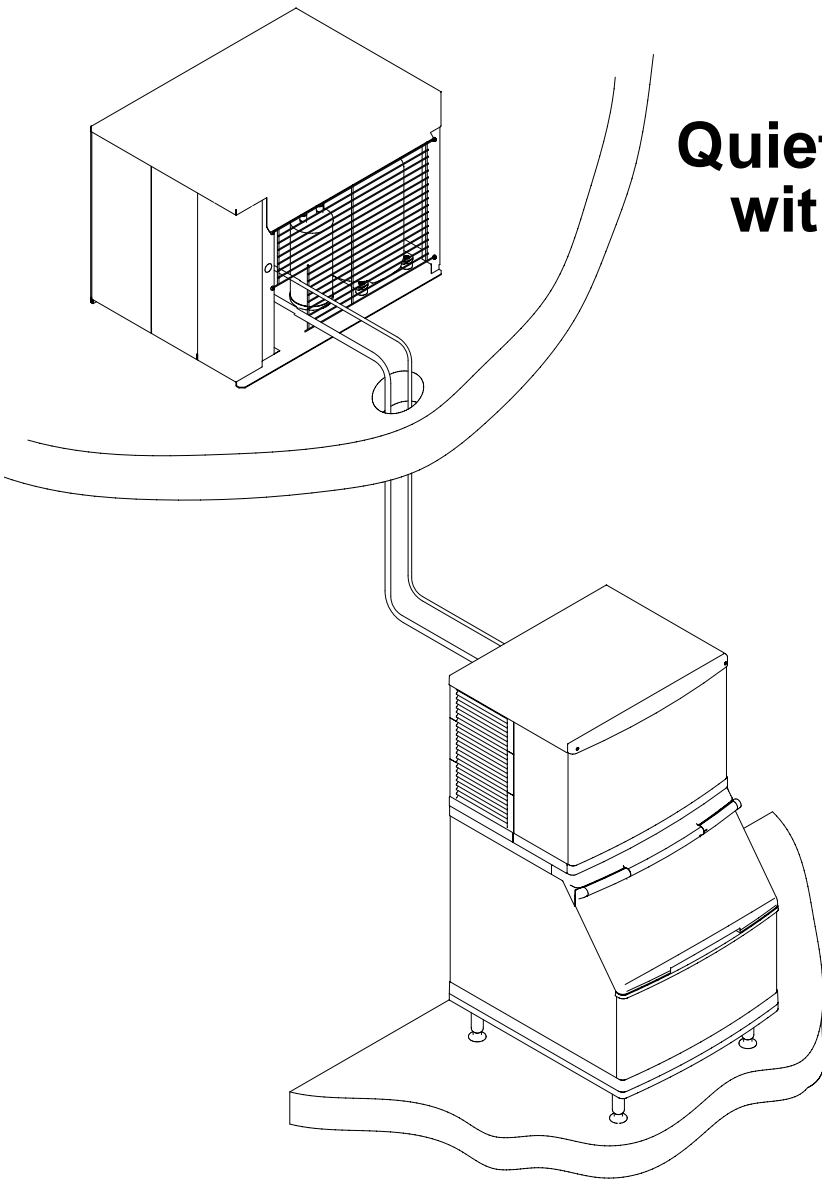

Thank you for selecting a Manitowoc Ice Machine, the dependability leader in ice making equipment and related products. With proper installation, care and maintenance, your new Manitowoc Ice Machine will provide you with many years of reliable and economical performance.

Safety Notices

As you work on a QuietQube®-Series Ice Machine, be sure to pay close attention to the safety notices in this manual. Disregarding the notices may lead to serious injury and/or damage to the ice machine.

Throughout this manual, you will see the following types of safety notices:

Warning

PERSONAL INJURY POTENTIAL

Do not operate equipment that has been misused, abused, neglected, damaged, or altered/modified from that of original manufactured specifications.

Warning

Text in a Warning box alerts you to a potential personal injury situation. Be sure to read the Warning statement before proceeding, and work carefully.

Caution

Text in a Caution box alerts you to a situation in which you could damage the ice machine. Be sure to read the Caution statement before proceeding, and work carefully.

Procedural Notices

As you work on a QuietQube®-Series Ice Machine, be sure to read the procedural notices in this manual. These notices supply helpful information which may assist you as you work.

Throughout this manual, you will see the following types of procedural notices:

Important

Text in an Important box provides you with information that may help you perform a procedure more efficiently. Disregarding this information will not cause damage or injury, but it may slow you down as you work.

NOTE: Text set off as a Note provides you with simple, but useful, extra information about the procedure you are performing.

Read These Before Proceeding:

Caution

Proper installation, care and maintenance are essential for maximum ice production and trouble-free operation of your Manitowoc Ice Machine. Read and understand this manual. It contains valuable care and maintenance information. If you encounter problems not covered by this manual, do not proceed, contact Manitowoc Ice, Inc. We will be happy to provide assistance.

Important

Routine adjustments and maintenance procedures outlined in this manual are not covered by the warranty.

We reserve the right to make product improvements at any time. Specifications and design are subject to change without notice.

Table of Contents

Section 1 General Information

| | |
|---|-----|
| Model Numbers | 1-1 |
| How to Read a Model Number | 1-1 |
| Remote Condensing Unit | 1-1 |
| Ice Cube Sizes | 1-1 |
| Accessories | 1-2 |
| CVD1476 Water Cooled Condensing Unit | 1-2 |
| Bin Caster | 1-2 |
| Ice Bagger | 1-2 |
| Ice Deflector | 1-2 |
| Water Filter System | 1-2 |
| Manitowoc Cleaner and Sanitizer | 1-2 |
| Dispenser | 1-2 |
| Aucs® Automatic Cleaning System | 1-2 |
| GSI200 | 1-2 |
| Model/Serial Number Location | 1-3 |
| Owner Warranty Registration Card | 1-4 |
| General | 1-4 |
| Warranty Coverage | 1-4 |
| General | 1-4 |
| Parts | 1-4 |
| Labor | 1-4 |
| Exclusions | 1-4 |
| Authorized Warranty Service | 1-4 |
| Service Calls | 1-4 |

Section 2 Installation Instructions

| | |
|--|-----|
| General | 2-1 |
| Ice Machine Installation Options | 2-1 |
| CVD1476 Condenser Water Pressure | 2-1 |
| Q1400C Head Section | 2-1 |
| Ice Machine Dimensions | 2-2 |
| Q1400C Ice Machines | 2-2 |
| Condensing Unit Dimensions | 2-2 |
| CVD1475 | |
| Air-Cooled | 2-2 |
| CVD1476 | |
| Water-Cooled | 2-2 |
| Ice Storage Bin Dimensions | 2-3 |
| Ice Machine Head Section Clearance Requirements | 2-4 |
| Stacking Two Ice Machines on a Single Storage Bin | 2-4 |
| Location of CVD Condensing Unit | 2-4 |
| Condensing Unit Clearance Requirements | 2-4 |
| Condensing Unit Heat of Rejection | 2-4 |
| Leveling the Ice Storage Bin | 2-5 |
| Air-Cooled Baffle | 2-5 |

Table of Contents (continued)

| | |
|--|------|
| Electrical Service | 2-6 |
| General | 2-6 |
| Voltage | 2-6 |
| Fuse/Circuit Breaker | 2-6 |
| Minimum Circuit Ampacity | 2-6 |
| Electrical Requirements | 2-7 |
| QuietQube® Ice Machine Head Section Electrical Wiring Connections | 2-8 |
| QuietQube® Ice Machine Head Section | |
| 115/1/60 | 2-8 |
| QuietQube® Ice Machine Head Section | |
| 230/1/50 | 2-8 |
| For United Kingdom Only | 2-8 |
| Remote Electrical Wiring Connections | 2-9 |
| CVD Condensing Unit 208-230/1/60 | 2-9 |
| CVD Condensing Unit 208-230/3/60 | 2-9 |
| CVD Condensing Unit 230/1/50 (CVD1475 Only) | 2-9 |
| Ice Machine Head Section Water Supply and Drains | 2-10 |
| Potable Water Supply | 2-10 |
| Potable Water Inlet Lines | 2-10 |
| Drain Connections | 2-10 |
| Water Cooled Condenser Water Supply and Drains | 2-10 |
| Condenser Water Supply | 2-10 |
| Water Cooled Condenser Lines | 2-10 |
| Condensing Unit Drain Connections | 2-10 |
| Water Supply and Drain Line Sizing/Connections | 2-11 |
| Refrigeration System Installation | 2-12 |
| Usage With Non-Manitowoc | |
| Condensing Units | 2-12 |
| Refrigeration Line Set Installation | 2-13 |
| General | 2-13 |
| A. Line Set Length | 2-13 |
| B. Line Set Rise or Drop | 2-13 |
| C. Suction Line Oil Traps | 2-14 |
| Installation Checklist | 2-20 |
| Before Starting the Ice Machine | 2-21 |
| AuCS® Automatic Cleaning System | 2-21 |

Section 3 Ice Machine Operation

| | |
|---|-----|
| Component Identification | 3-1 |
| Ice Machine Head Section | 3-1 |
| CVD Condensing Unit | 3-2 |
| Ice Making Sequence of Operation | 3-3 |
| Initial Start-Up or Start-Up After Automatic Shut-Off | 3-3 |
| Freeze Sequence | 3-3 |
| Harvest Sequence | 3-3 |
| Automatic Shut-Off | 3-3 |
| Operational Checks | 3-4 |
| General | 3-4 |
| Water Level | 3-4 |
| Water float valve check | 3-4 |
| Ice Thickness Check | 3-4 |

Table of Contents (continued)

**Section 4
Maintenance**

| | |
|---|-------------|
| Interior Cleaning and Sanitizing | 4-1 |
| Cleaning and Sanitizing Procedure | 4-1 |
| Ice Machine Inspection | 4-8 |
| Exterior Cleaning | 4-8 |
| Cleaning the Condenser | 4-8 |
| General | 4-8 |
| Water-Cooled Condenser and Water Regulating Valve | 4-9 |
| Removal from Service/Winterization | 4-10 |
| General | 4-10 |
| CVD 1476 Water Cooled Condensing Unit | 4-10 |
| AuCS Accessory | 4-10 |

**Section 5
Before Calling For Service**

| | |
|-----------------------------------|------------|
| Checklist | 5-1 |
| Safety Limit Feature | 5-2 |

Table of Contents (continued)

Section 1

General Information

Model Numbers

This manual covers the following models:

| Ice Machine Head Section | CVD® Condensing Unit* |
|--------------------------|-----------------------|
| QD1472C | CVD1375 |
| QY1474C | CVD1475 |
| | CVD1476 |

For 3 phase electrical option: add the number "3" to the end of model number (CVD14753).

Warning

PERSONAL INJURY POTENTIAL

Do not operate equipment that has been misused, abused, neglected, damaged, or altered/modified from that of original manufactured specifications.

Warning

When installing with non-Manitowoc ice storage systems or Manitowoc F & B style bins. Manitowoc QuietQube® ice machines require the ice storage bin, to incorporate an ice deflector.

Prior to using a non-Manitowoc ice storage system with Manitowoc ice machines, contact the manufacturer to assure their ice deflector is compatible with Manitowoc ice machines.

How to Read a Model Number

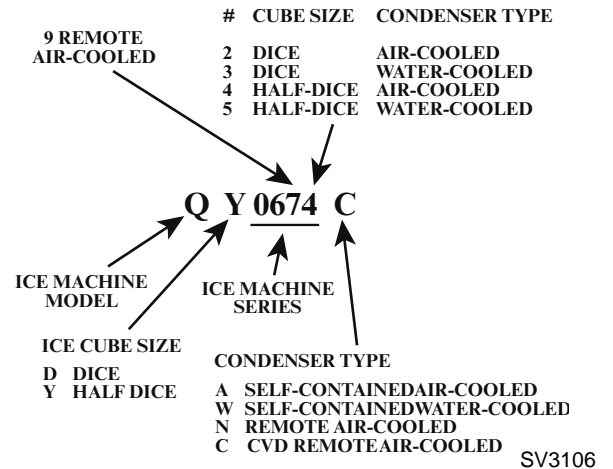

Remote Condensing Unit

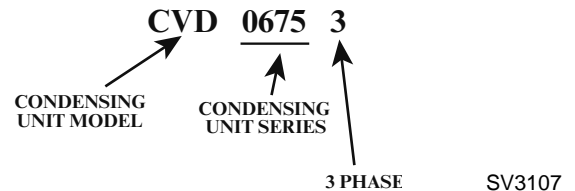

Ice Cube Sizes

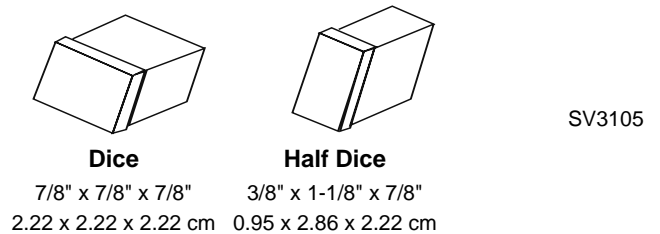

Important

The ice machine sequence of operation for QuietQube® ice machines will differ. Verify the correct sequence of operation is followed for the model you are working on.

Accessories

Contact your Manitowoc distributor for these optional accessories:

**CVD1476 WATER COOLED CONDENSING UNIT
(With High Pressure Water Regulating Valve)**

A special order condensing unit is available that allows condenser water inlet pressure up to 350 psig (2413 kPA).

BIN CASTER

Replaces standard legs.

ICE BAGGER

Maximize profits from bagged ice sales with this convenient accessory. This sturdy unit rests on the bin door frame, and adapts for left or right side filling.

ICE DEFLECTOR

Q1400C ice machines mounted on an ice dispenser do not require an ice deflector.

Q1400C ice machines mounted on an ice storage bin (Manitowoc or non-Manitowoc) require the use of an ice deflector.

Two Q1400C ice machines can be mounted side by side on a Manitowoc 60" F & B Style bin.

 **Warning**

Manitowoc Q1400C ice machines require the ice storage bin to incorporate an ice deflector. The deflector kit is not included with the ice machine and must be ordered separately. Prior to using a non-Manitowoc ice storage system with Manitowoc ice machines, contact the manufacturer to assure their ice deflector is compatible with Manitowoc ice machines.

Contact your sales representative or the factory sales department to determine the proper kit for bin applications.

WATER FILTER SYSTEM

Engineered specifically for Manitowoc ice machines, This water filter is an efficient, dependable, and affordable method of inhibiting scale formation, filtering sediment, and removing chlorine taste and odor.

MANITOWOC CLEANER AND SANITIZER

Manitowoc Ice Machine Cleaner and Sanitizer are available in convenient 16 oz. (473 ml) and 1 gal (3.78 l) bottles. These are the only cleaner and sanitizer approved for use with Manitowoc products.

| Cleaner Part Number | | Sanitizer Part Number | |
|---------------------|-----------|-----------------------|-----------|
| 16 oz. | 94-0456-3 | 16 oz. | 94-0565-3 |
| 1 Gallon | 94-0580-3 | 1 Gallon | 94-0581-3 |

DISPENSER

A counter-top dispenser is ideal for cafeterias and many types of self-service facilities. Manitowoc auto-fill, floor-standing ice dispensers meet the strict sanitary requirements of the food service, lodging and health care industries.

AUCS® AUTOMATIC CLEANING SYSTEM

This accessory reduces equipment cleaning expense. The AuCS® accessory monitors ice making cycles and initiates cleaning procedures automatically.

GS1200

This accessory releases chlorine dioxide on a controlled basis to inhibit the growth of bacteria and slime.

Model/Serial Number Location

Record the model and serial number of your ice machine and bin or dispenser in the space provided below.

These numbers are required when requesting information from your local Manitowoc distributor, service representative, or Manitowoc Ice, Inc.

The model and serial number are listed on the OWNER WARRANTY REGISTRATION CARD. They are also listed on the MODEL/SERIAL NUMBER DECAL affixed to the ice machine head section and condensing unit. Both model/serial numbers must be referenced to obtain warranty or service information.

Condensing Unit

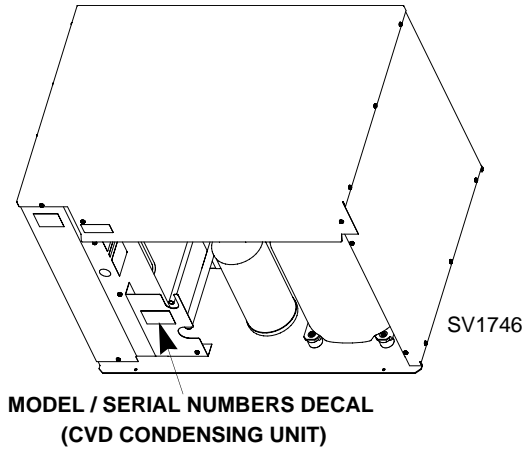

Back of Ice Machine

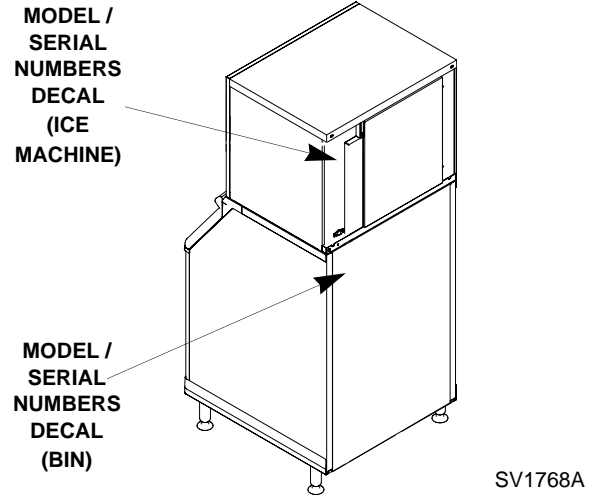

Q1400C

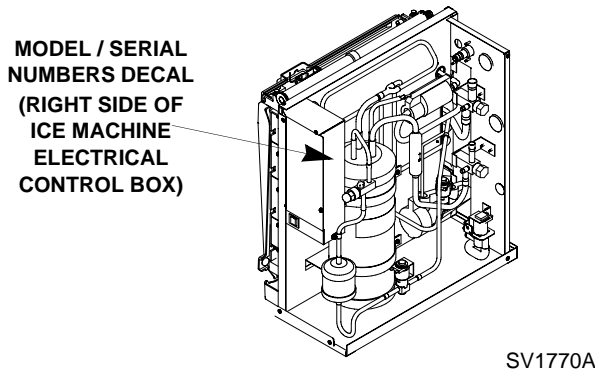

CVD1476 Condensing Unit

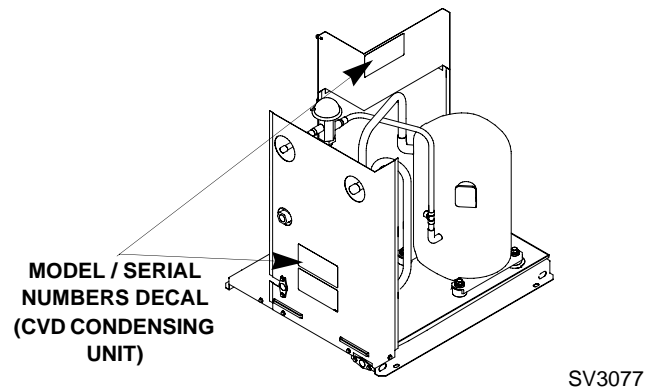

Model/Serial Number Location

| | Ice Machine | Bin or Dispenser | CVD Condensing Unit | AuCS Accessory |
|---------------|-------------|------------------|---------------------|----------------|
| Model Number | | | | |
| Serial Number | | | | |

Owner Warranty Registration Card

GENERAL

The packet containing this manual also includes warranty information. Warranty coverage begins the day the ice machine is installed.

Important

Complete and mail the OWNER WARRANTY REGISTRATION CARD as soon as possible to validate the installation date.

If the OWNER WARRANTY REGISTRATION CARD is not returned, Manitowoc will use the date of sale to the Manitowoc Distributor as the first day of warranty coverage for your new ice machine.

Warranty Coverage

GENERAL

The following Warranty outline is provided for your convenience. For a detailed explanation, read the warranty bond shipped with each product.

Contact your local Manitowoc Distributor or Manitowoc Ice, Inc. if you need further warranty information.

Important

This product is intended exclusively for commercial application. No warranty is extended for personal, family, or household purposes.

PARTS

1. Manitowoc warrants the ice machine against defects in materials and workmanship, under normal use and service for three (3) years from the date of original installation.
2. The evaporator and compressor are covered by an additional two (2) year (five years total) warranty beginning on the date of the original installation.

LABOR

1. Labor required to repair or replace defective components is covered for three (3) years from the date of original installation.
2. The evaporator is covered by an additional two (2) year (five years total) labor warranty beginning on the date of the original installation.

EXCLUSIONS

The following items are not included in the ice machine's warranty coverage:

1. **Normal maintenance**, adjustments and cleaning as outlined in this manual.
2. Repairs due to unauthorized modifications to the ice machine or use of non-standard parts without prior written approval from Manitowoc Ice, Inc.
3. Damage caused by improper installation of the ice machine, electrical supply, water supply or drainage, or damage caused by floods, storms, or other acts of God.
4. **Premium labor rates** due to holidays, **overtime**, etc.; travel time; flat rate service call charges; mileage and miscellaneous tools and material charges not listed on the payment schedule. Additional labor charges resulting from the inaccessibility of equipment are also excluded.
5. Parts or assemblies subjected to misuse, abuse, neglect or accidents.
6. Damage or problems caused by installation, cleaning and/or maintenance procedures inconsistent with the technical instructions provided in this manual.
7. This product is intended exclusively for commercial application. No warranty is extended for personal, family, or household purposes.

AUTHORIZED WARRANTY SERVICE

To comply with the provisions of the warranty, a refrigeration service company qualified and authorized by a Manitowoc distributor, or a Contracted Service Representative must perform the warranty repair.

NOTE: If the dealer you purchased the ice machine from is not authorized to perform warranty service; contact your Manitowoc distributor or Manitowoc Ice, Inc. for the name of the nearest authorized service representative.

SERVICE CALLS

Normal maintenance, adjustments and cleaning as outlined in this manual are not covered by the warranty. If you have followed the procedures listed in this manual, and the ice machine still does not perform properly, call your Local Distributor or the Service Department at Manitowoc Ice, Inc.

Section 2

Installation Instructions

General

These instructions are provided to assist the qualified installer. Check your local Yellow Pages for the name of the nearest Manitowoc distributor, or call Manitowoc Ice, Inc. for information regarding installation and start-up services.

Important

Failure to follow these installation guidelines may affect warranty coverage.

Ice Machine Installation Options

CVD1476 CONDENSER WATER PRESSURE

Water pressure at the condenser cannot exceed 150 psig (1034 kPa) with the standard water-regulating valve. Contact your distributor if your water pressure is greater than 150 psig (1034 kPa). A special order condensing unit is available that allows water pressure up to 350 psig (2413 kPa).

Q1400C HEAD SECTION

The ice machine head can be installed with the electrical inlet, water supply inlet and refrigeration tubing entering from the back or top of the ice machine.

The ice machine water drain must exit the back of the ice machine.

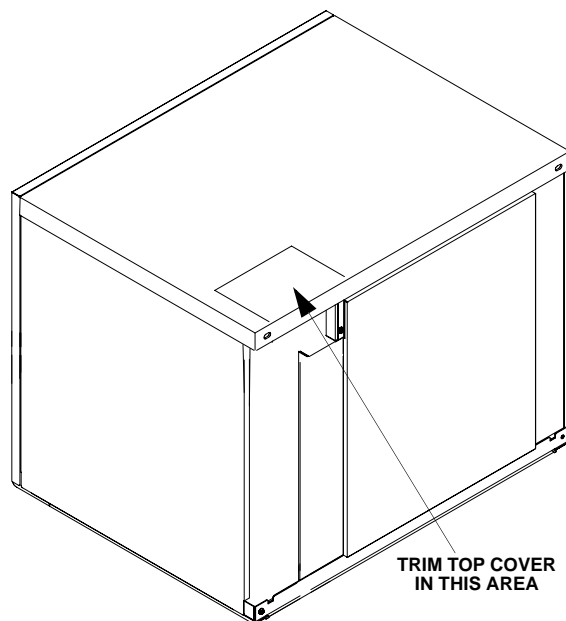
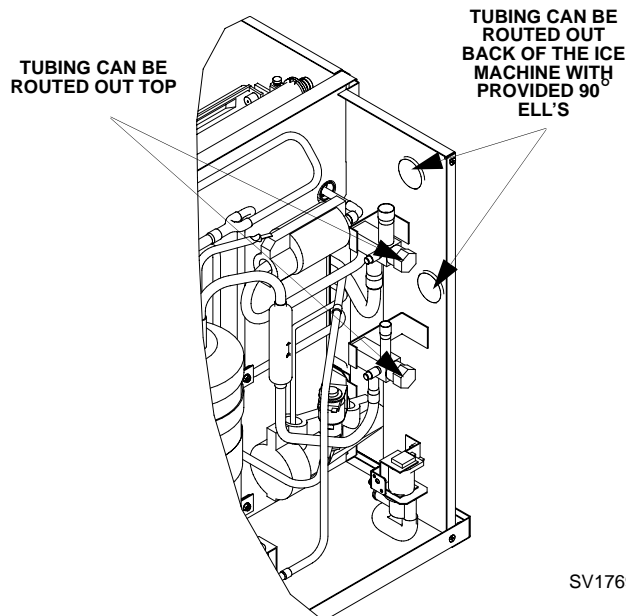

Cut the top cover for top routing of electrical inlet, water supply inlet or refrigeration lines.

1. Prior to cutting, mount top cover onto ice machine.
2. Locate the area that will need to be cut and mark the top cover.
3. Using a tin snips, cut top cover as needed:
 - A. Do not cut out entire area! Cut up to 1/8 inch to marked line.
 - B. Cut out only what is needed. (If routing only refrigeration lines out the top, cut just enough to route these lines.) Do not cut out the entire corner area.

Ice Machine Dimensions

Q1400C ICE MACHINES

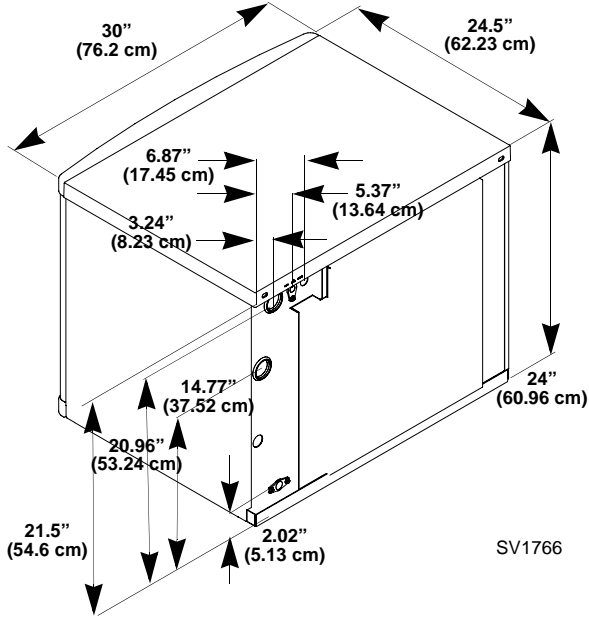

Important

Failure to follow these installation guidelines may affect warranty coverage.

Condensing Unit Dimensions

CVD1475
Air-Cooled

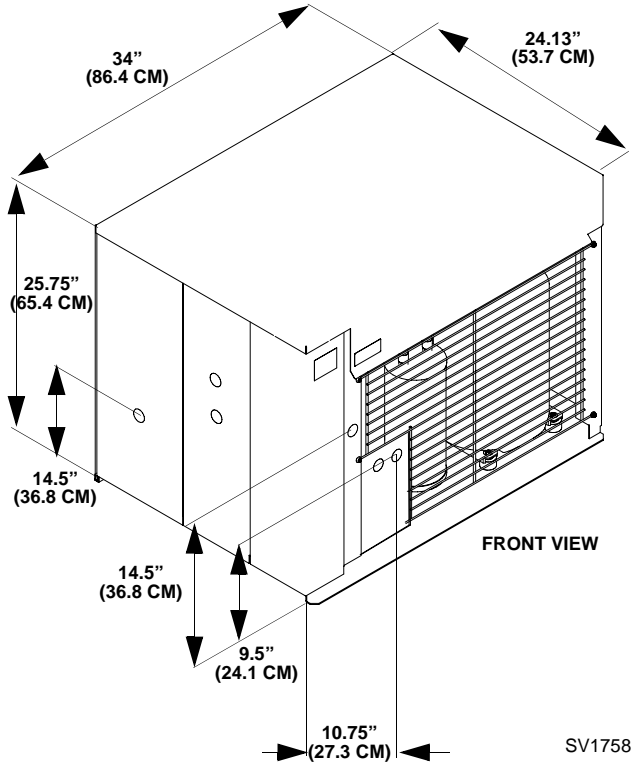

CVD1476
Water-Cooled

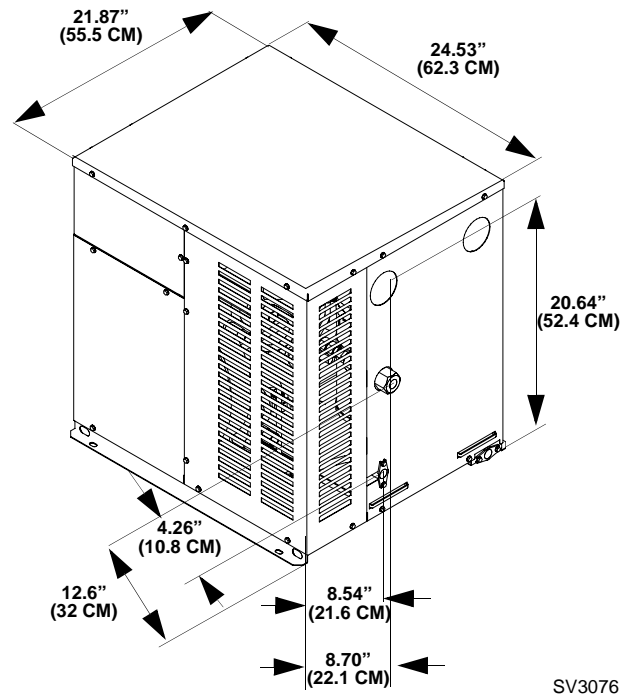

Ice Storage Bin Dimensions

S970 ICE STORAGE BIN

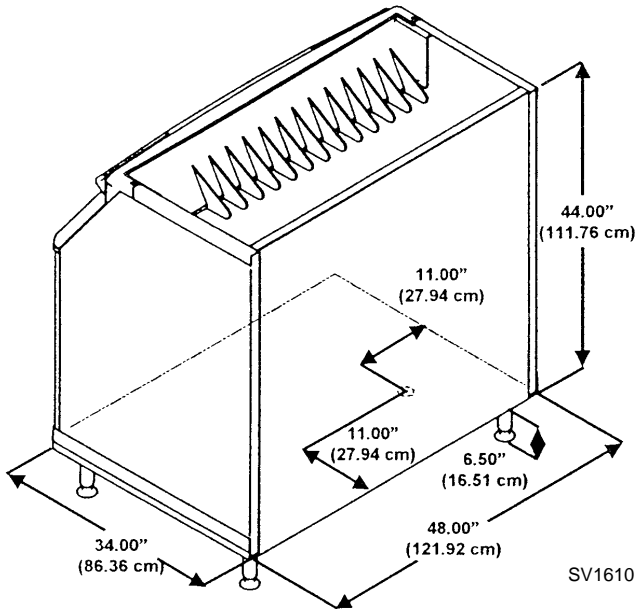

Large Capacity Ice Storage Bin Dimensions

30 INCH (76 CM)

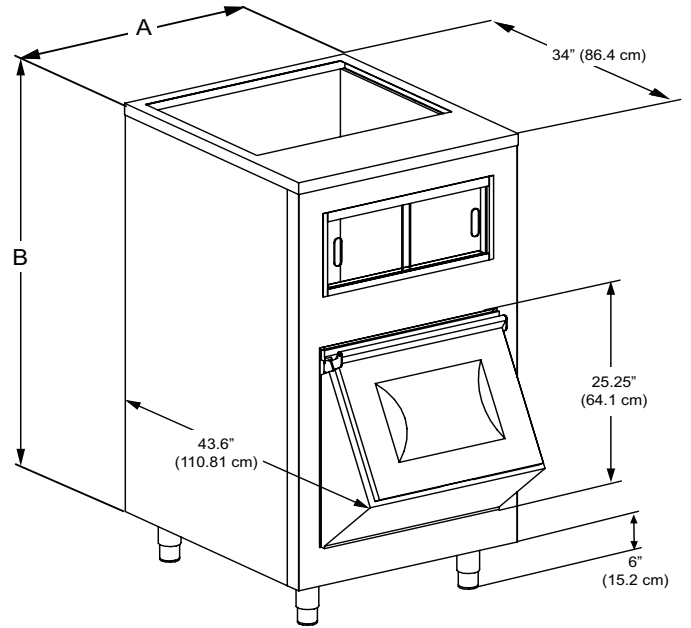

Warning
 All Manitowoc ice machines require the ice storage system (bin, dispenser, etc.) to incorporate an ice deflector.
 The Manitowoc Q1400C ice machines require adding Manitowoc Ice Deflector Kit when installing with non-Manitowoc ice storage systems or 60" Manitowoc F & B style bins.
 Prior to using a non-Manitowoc ice storage system with other Manitowoc ice machines, contact the manufacturer to assure their ice deflector is compatible with Manitowoc ice machines.

Caution
 30" large capacity ice storage bins must be attached to the wall with the bracket provided with the bin.

| Bin Model | Dimension A (Width) | Dimension B (Height) |
|-----------|---------------------|----------------------|
| B750 | 30 in. (76.2 cm.) | 58 in. (147.3 cm.) |
| B1050 | 30 in. (76.2 cm.) | 78 in. (198.1 cm.) |

The bin drain is exactly in the center of the bin.

48 INCH (122 CM) & 60 INCH (152 CM)

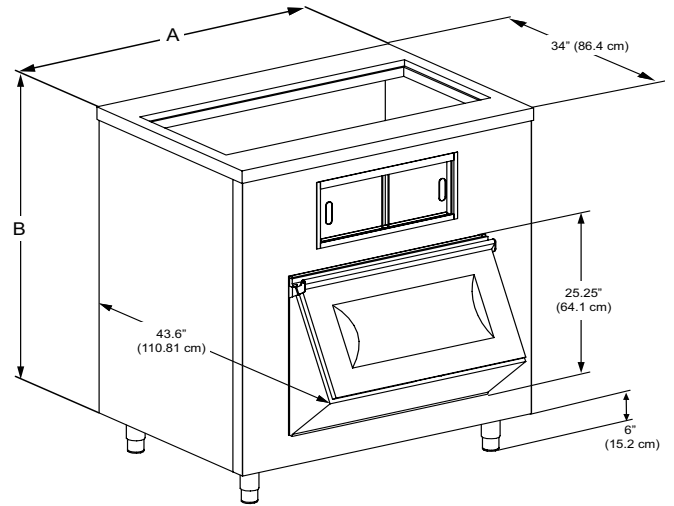

| Bin Model | Dimension A (Width) | Dimension B (Height) |
|-----------|---------------------|----------------------|
| B1100 | 48 in. (121.9 cm.) | 55.0 in. (139.7 cm.) |
| B1400 | 60 in. (152.4 cm.) | 55.0 in. (139.7 cm.) |

The bin drain is exactly in the center of the bin.

Location of Ice Machine

The location selected for the ice machine must meet the following criteria. If any of these criteria are not met, select another location.

- The location must be free of airborne and other contaminants.
- The air temperature must be at least 35°F (1.6°C), but must not exceed 110°F (43.4°C).
- The location must not be near heat-generating equipment or in direct sunlight.
- The location must not obstruct airflow through or around the ice machine. Refer to the chart below for clearance requirements.

Ice Machine Head Section Clearance Requirements

Q1400C:

Top/Sides 5" (127 mm) is recommended for efficient operation and servicing. There is no minimum clearance required.

Back 1" (25.4 mm) required when routing electrical inlet, water inlet and refrigeration tubing out of the top of the unit.

5" (127 mm) required when routing all connections out the back.

⚠ Caution

The ice machine head section must be protected if it will be subjected to temperatures below 32°F (0°C). Failure caused by exposure to freezing temperatures is not covered by the warranty. See "Removal from Service/Winterization".

Stacking Two Ice Machines on a Single Storage Bin

Q1400C:

Q1400C ice machines cannot be stacked. However an adapter is available that allows two Q1400C ice machines to be placed side by side on 60" Manitowoc F & B style bins.

Location of CVD Condensing Unit

The location selected for the CVD Condensing Unit must meet the following criteria. If any of these criteria are not met, select another location.

- CVD1475 - The air temperature must be at least -20°F (-28.9°C) but must not exceed 130°F (54.4°C).
- CVD1476 - The air temperature must be at least 50°F (10°C) but must not exceed 110°F (43°C).
- The location must not allow exhaust fan heat and/or grease to enter the condenser.
- The location must not obstruct airflow through or around the condensing unit. Refer to the chart below for clearance requirements.

Condensing Unit Clearance Requirements

Top/Sides

There is no minimum clearance required, although 6" (152 mm) is recommended for efficient operation and servicing only.,

Front/Back

48" (122 cm)

CVD1476 ONLY

Top - 5" (127 mm) is recommended for efficient operation and servicing only.

Front/Back/Sides - 12" (305 mm)

Condensing Unit Heat of Rejection

| Series Condensing Unit | Heat of Rejection* | |
|---------------------------|--------------------|--------|
| | Air Conditioning** | Peak |
| CVD1475 | 24,000 | 35,500 |
| CVD1476 | | |

B.T.U./Hour
Because the heat of rejection varies during the ice making cycle, the figure shown is an average.

Ice machines, like other refrigeration equipment, reject heat through the condenser. It is helpful to know the amount of heat rejected by the ice machine when sizing air conditioning equipment where self-contained air-cooled ice machines are installed.

This information is also necessary when evaluating the benefits of using water-cooled or CVD® Condensing Units to reduce air conditioning loads. The amount of heat added to an air-conditioned environment by a QuietQube® ice machine head section is negligible.

Leveling the Ice Storage Bin

1. Screw the leveling legs onto the bottom of the bin.
2. Screw the foot of each leg in as far as possible.

⚠ Caution

The legs must be screwed in tightly to prevent them from bending.

3. Move the bin into its final position.
4. Level the bin to assure that the bin door closes and seals properly. Use a level on top of the bin. Turn each foot as necessary to level the bin.

NOTE: An optional caster assembly is available for use in place of the legs. Installation instructions are supplied with the casters.

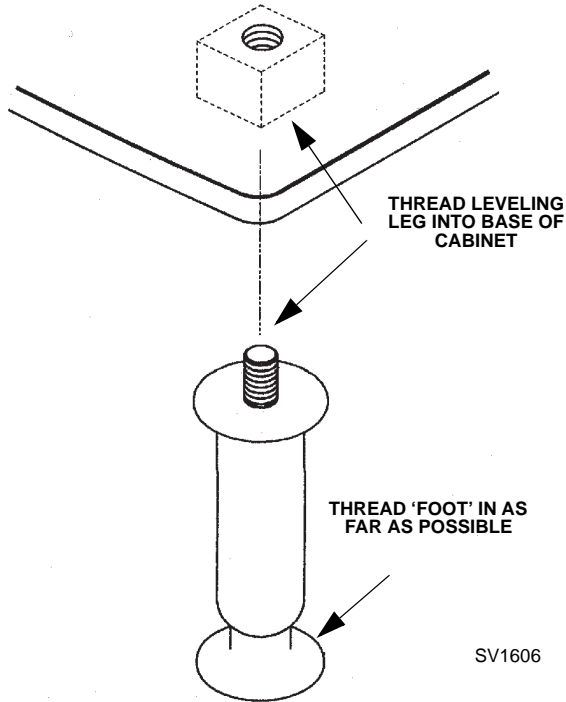

Leveling Leg and Foot

Air-Cooled Baffle

The air-cooled baffle prevents condenser air from recirculating. To install:

1. Remove the back panel screws next to the condenser.
2. Align the mounting holes in the air baffle with the screw holes and reinstall the screws.

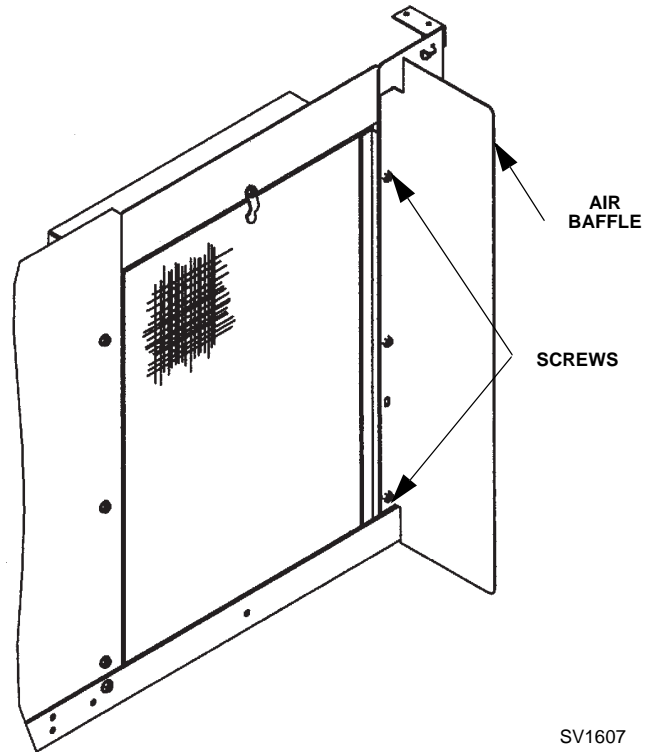

Air Baffle

Electrical Service

GENERAL

 **Warning**

All wiring must conform to local, state and national codes.

VOLTAGE

For both the Ice Machine Head Section and the CVD® Condensing Unit, the maximum allowable voltage variation is $\pm 10\%$ of the rated voltage at ice machine start-up (when the electrical load is highest).

 **Warning**

The ice machine and condensing unit must be grounded in accordance with national and local electrical codes.

FUSE/CIRCUIT BREAKER

The ice machine head section and condensing unit are wired independently from each other.

Ice Machine Head Section

The ice machine head section does not require a dedicated circuit breaker.

CVD® Condensing Unit

A separate fuse/circuit breaker must be provided for each condensing unit. Circuit breakers must be H.A.C.R. rated (does not apply in Canada).

MINIMUM CIRCUIT AMPACITY

The minimum circuit ampacity is used to help select the wire size of the electrical supply. (Minimum circuit ampacity is not the ice machine's running amp load.) The wire size (or gauge) is also dependent upon location, materials used, length of run, etc., so it must be determined by a qualified electrician.

GROUND FAULT CIRCUIT INTERRUPTER

Ground Fault Circuit Interrupter (GFCI/GFI) protection is a system that shuts down the electric circuit (opens it) when it senses an unexpected loss of power, presumably to ground. Manitowoc Ice, Inc. does not recommend the use of a GFCI/GFI circuit protection with our equipment. If code requires the use of a GFCI/GFI then you must follow the local code. The circuit must be dedicated, sized properly and there must be a panel GFCI/GFI breaker. We do not recommend GFCI/GFI outlets as they are known for more intermittent nuisance trips than panel breakers.

Electrical Requirements

QuietQube® Ice Machine Head Section

| Ice Machine | Voltage Phase Cycle | Maximum Fuse/ Circuit Breaker | Total Amps |
|-------------|---------------------------|----------------------------------|------------|
| Q1400C | 115/1/60 | 15 amp | 1.1 |
| | 208-230/1/60 | 15 amp | 0.6 |
| | 230/1/50 | 15 amp | 0.6 |

Important

The QuietQube® Ice Machine Head Section and CVD Condensing Unit are wired independently from each other.

CVD® Condensing Unit

| Condensing Unit | Voltage Phase Cycle | Maximum Fuse/Circuit Breaker | Minimum Circuit Amps |
|-----------------|------------------------|---------------------------------|----------------------|
| CVD1475 | 208-230/1/60 | 35 | 19.6 |
| | 208-230/3/60 | 25 | 14.1 |
| | 230/1/50 | 35 | 19.8 |
| CVD1476 | 208-230/1/60 | 30 | 15.3 |
| | 208-230/3/60 | 20 | 10.8 |

QuietQube® Ice Machine Head Section Electrical Wiring Connections

Warning

These diagrams are not intended to show proper wire routing, wire sizing, disconnects, etc., only the correct wire connections.

All electrical work, including wire routing and grounding, must conform to local, state and national electrical codes.

Though wire nuts are shown in the drawings, the ice machine field wiring connections may use either wire nuts or screw terminals.

**QUIETQUBE® ICE MACHINE HEAD SECTION
115/1/60**

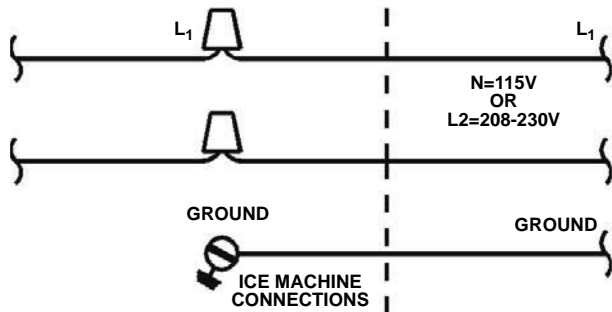

SV1258

**QUIETQUBE® ICE MACHINE HEAD SECTION
230/1/50**

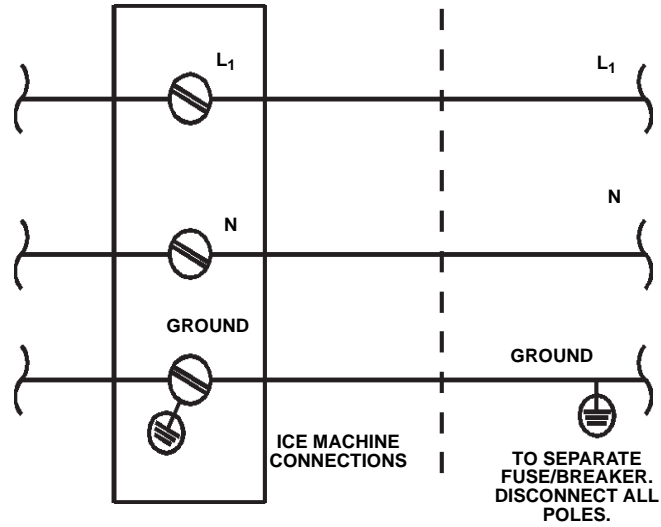

SV1191

For United Kingdom Only

As the colours of the wires in the mains lead of the appliance may not correspond with the coloured markings identifying the terminals in your plug, proceed as follows:

- The wire which is coloured green and yellow must be connected to the terminal in the plug which is marked with the letter E or by the earth ground symbol  or coloured green or green and yellow.
- The wire coloured blue must be connected to the terminal which is marked with the letter N or coloured black.
- The wire coloured brown must be connected to the terminal which is marked with the letter L or coloured red.

Remote Electrical Wiring Connections

Warning

These diagrams are not intended to show proper wire routing, wire sizing, disconnects, etc., only the correct wire connections.

All electrical work, including wire routing and grounding, must conform to local, state and national electrical codes.

Though wire nuts are shown in the drawings, the ice machine field wiring connections may use either wire nuts or screw terminals.

**CVD CONDENSING UNIT
208-230/1/60**

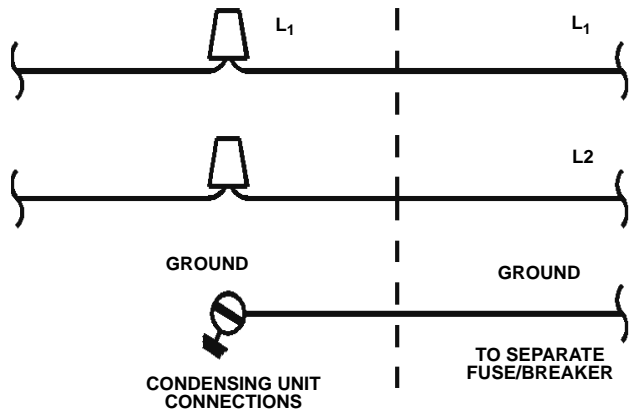

**CVD CONDENSING UNIT
208-230/3/60**

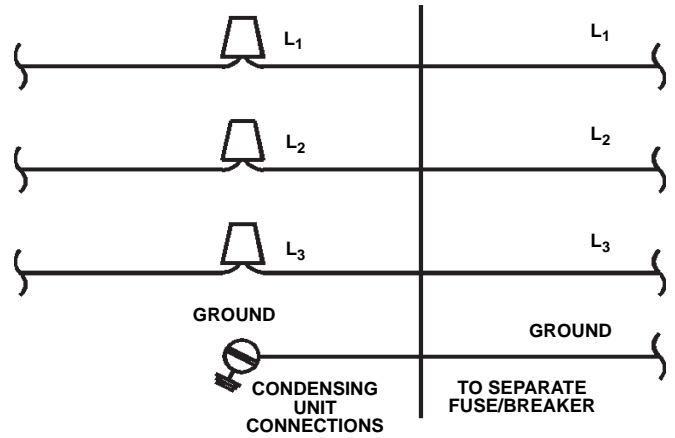

**CVD CONDENSING UNIT
230/1/50 (CVD1475 ONLY)**

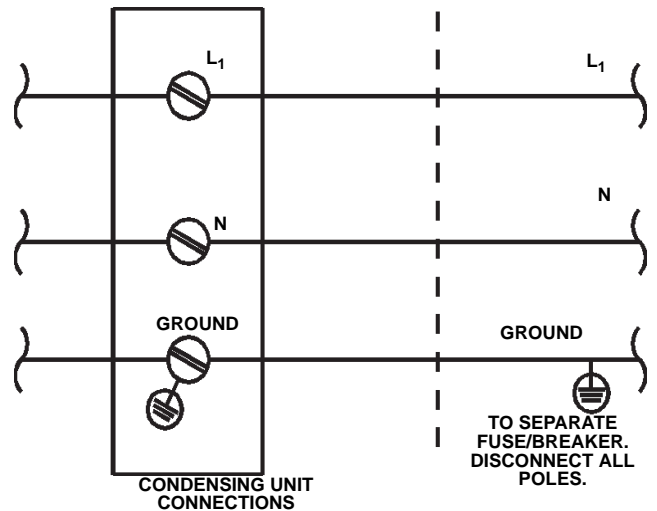

Ice Machine Head Section Water Supply and Drains

POTABLE WATER SUPPLY

Local water conditions may require treatment of the water to inhibit scale formation, filter sediment, and remove chlorine odor and taste.

Important

If you are installing a Manitowoc water filter system, refer to the Installation Instructions supplied with the filter system for ice making water inlet connections.

POTABLE WATER INLET LINES

Follow these guidelines to install water inlet lines:

- Do not connect the ice machine to a hot water supply. Be sure all hot water restrictors installed for other equipment are working. (Check valves on sink faucets, dishwashers, etc.)
- If water pressure exceeds the maximum recommended pressure, obtain a water pressure regulator from your Manitowoc distributor. Float Valve - 80 psig (551.5 kPA)
- Install a water shut-off valve for ice making potable water.
- Insulate water inlet lines to prevent condensation.

DRAIN CONNECTIONS

Follow these guidelines when installing drain lines to prevent drain water from flowing back into the ice machine and storage bin:

- Drain lines must have a 1.5 inch drop per 5 feet of run (2.5 cm per meter), and must not create traps.
- The floor drain must be large enough to accommodate drainage from all drains.
- Run separate bin and ice machine drain lines. Insulate them to prevent condensation.
- Vent the bin and ice machine drain to the atmosphere. The ice machine drain requires an 18" vent.

Water Cooled Condenser Water Supply and Drains

CONDENSER WATER SUPPLY

Local water conditions may require treatment of the water to inhibit scale formation, filter sediment, and remove chlorine odor and taste.

WATER COOLED CONDENSER LINES

Follow these guidelines to install water lines:

- Contact your distributor if your water pressure is greater than 150 psig (1034 kPA). A special order condensing unit is available that allows water pressure up to 350 psig (2413 kPA).
- Install a shutoff valve (inlet and outlet on cooling tower or closed loop circuits) to allow isolation of the water system.
- Water entering the condenser must not exceed 90°F (32.2°C).
- Water flow through the condenser must not exceed 5 gallons (19 liters) per minute.
- Allow for a pressure drop of 8 psig (55 kPA) between the condenser water inlet and outlet.
- Water exiting the condenser must not exceed 110°F (43.3°C).

CONDENSING UNIT DRAIN CONNECTIONS

The condensing unit drain is provided to remove any condensate produced by the suction accumulator. Condensate amounts will vary depending on temperature and humidity.

- The condensing unit must be level front to back and side to side to allow the condensate to drain.
- Drain lines must have a 1.5-inch drop per 5 feet of run (2.5 cm per meter), and must not create traps.
- Drain termination must meet applicable costs.

WATER SUPPLY AND DRAIN LINE SIZING/CONNECTIONS

⚠ Caution
Plumbing must conform to state and local codes.

| Location | Water Temperature | Water Pressure | Ice Machine Fitting | Tubing Size Up to Ice Machine Fitting |
|---------------------------------|---|--|-------------------------|---------------------------------------|
| Ice Making Water Inlet | 33°F (0.6°C) Min. 90°F (32.2°C) Max. | 20 psi (137.9 kPA) Min. 80 psi (551.5 kPA) Max. | 3/8" Female Pipe Thread | 3/8" (9.5 mm) min. inside diameter |
| Water Cooled Condenser | 33°F (0.6°C) Min. 90°F (32.2°C) Max. | 20 psi (137.9 kPA) Min. 80 psi (551.5 kPA) Max. CVD1476 20 psi (137.9 kPA) Min. 350 psi (2413 kPA) Max. | 1/2" Female Pipe Thread | 1/2" (12.7 mm) min. inside diameter |
| Ice Making Water Drain | --- | --- | 1/2" Female Pipe Thread | 1/2" (12.7 mm) min. inside diameter |
| Bin Drain | --- | --- | 3/4" Female Pipe Thread | 3/4" (19.1 mm) min. inside diameter |
| Large Capacity Bin Drain | --- | --- | 1" Female Pipe Thread | 1" (25.4 mm) min. inside diameter |

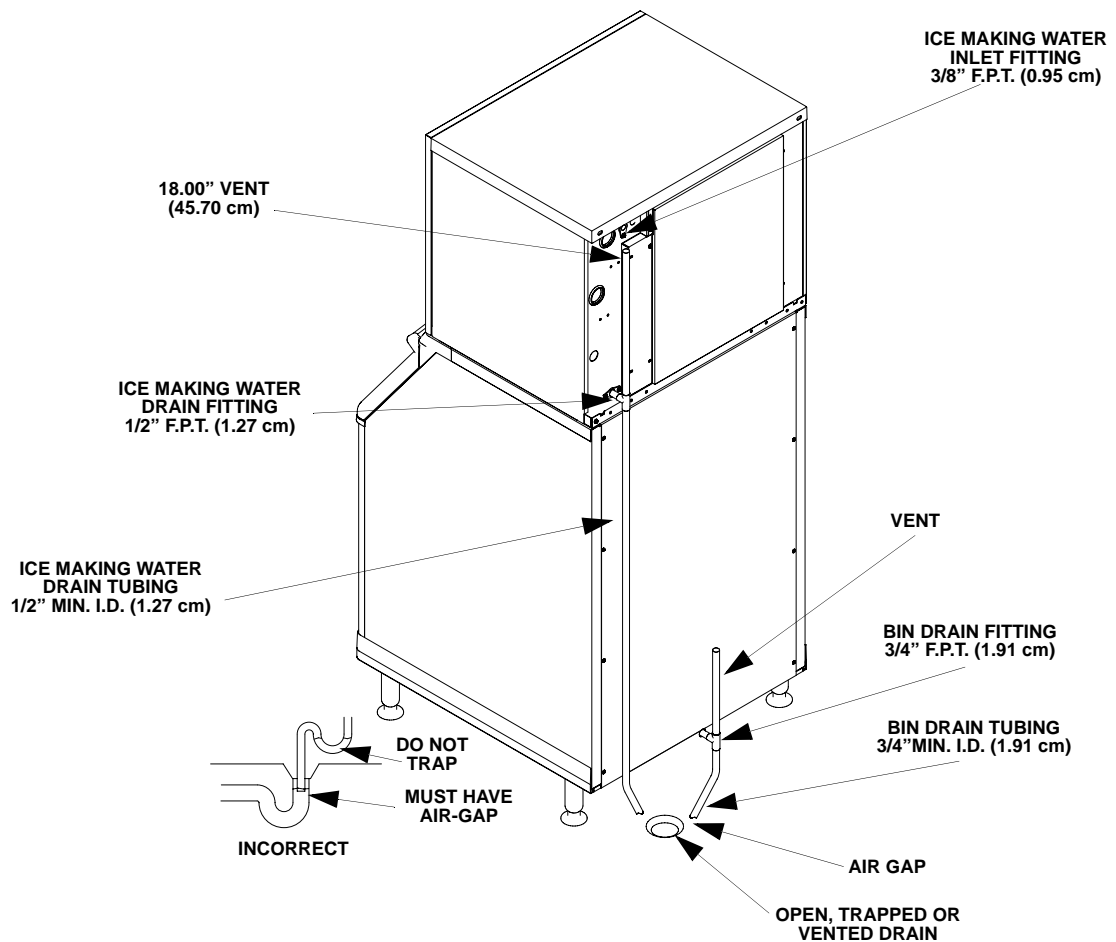

Refrigeration System Installation

| QuietQube® Ice Machine | Remote Single Circuit Condenser | Line Set* |
|------------------------|---------------------------------|-------------------------|
| Q1400C | CVD1475 CVD1476 | RC-20 RC-30 RC-50 |

| Line Set | Suction Line | Liquid Line | Insulation Thickness |
|-------------|-----------------------|-----------------------|--|
| RC 20/30/50 | 3/4 inch (19.1 mm) | 1/2 inch (12.7 mm) | 1/2" (13mm) Suction Line 1/4" (7mm) Liquid Line |

USAGE WITH NON-MANITOWOC CONDENSING UNITS

Manitowoc CVD® Condensing Units are specifically designed for usage with a QuietQube® Ice Machine Head Section. Standard condensing units and Non-Manitowoc condensing units will not operate a QuietQube® Ice Machine Head Section.

⚠ Caution

The 60-month compressor warranty (including the 36-month labor replacement warranty) will not apply if the Manitowoc Ice Machine and Manitowoc CVD Condensing Unit are not installed according to specifications. This warranty also will not apply if the refrigeration system is modified with a condenser, heat reclaim device, or other parts or assemblies not manufactured by Manitowoc Ice, Inc.

Factory Equipment Refrigeration Amounts

ICE MACHINE HEAD SECTION

Each ice machine head section ships from the factory with a R-404A refrigerant charge appropriate for the entire system operation. The serial tag on the ice machine indicates the refrigerant charge. The refrigerant charge is sufficient to operate the ice machine in ambient temperatures between -20°F (-28.9°C) and 130°F (54.4°C)*. With line set lengths of up to 100 feet (30.5 m).

***CVD1476** - 50°F to 110°F (10°C to 43°C)

⚠ Warning

The ice machine head section contains the refrigerant charge. Installation and brazing of the line sets must be performed by a properly trained and EPA certified refrigeration technician aware of the **dangers of dealing with refrigerant** charged equipment.

⚠ Caution

Never add more than nameplate charge to the refrigeration system for any application.

CVD® CONDENSING UNIT

Each condensing unit ships from the factory pressurized with 50/50 nitrogen helium mixture that must be removed during the installation process (approximately 20 psig).

REFRIGERATION LINE SETS/TRAP KIT

Refrigeration Rated Tubing and Trap Kits are shipped capped with atmospheric pressure.

⚠ Warning

Installation of a QuietQube® Condensing Unit may require the use of special equipment for placement. Trained and qualified personnel are required for proper rigging and lifting.

Refrigeration Line Set Installation

GENERAL

Refrigeration line set installations consist of vertical and horizontal line set distances between the ice machine and the condensing unit. The following guidelines, drawings and calculation methods must be followed to assure proper oil return and CVD® condensing unit/ice machine operation.

The refrigeration line set installer must be USA Government-Environmental Protection Agency (EPA) certified in proper refrigerant handling and servicing procedures.

Warning

The ice machine head section contains refrigerant charge. The ice machine head section contains three (3) refrigeration valves that **must remain closed** until proper installation of the line sets is completed.

Warning

Disconnect electrical power to the ice machine head section and CVD® condensing unit before proceeding.

Step 1 Verify Ice Machine and CVD® Condensing Unit Locations Are Within Guidelines.

Prior to installation of the ice machine head section and CVD® condensing unit be sure that the distance between them is within the line set routing guidelines outlined in this manual.

Roof/Wall Penetration

If required, cut a 3-inch (76.2 mm) circular hole in the wall or roof for routing of refrigeration tubing. A qualified person must perform all roof penetrations.

Step 2 Route Refrigeration Tubing

Properly route refrigeration tubing between the ice machine head section and the CVD® condensing unit.

A. LINE SET LENGTH

100 feet (30.5 m) Length: The maximum measured length the line set can be.

The receiver is designed to hold a charge sufficient to operate the ice machine in ambient temperatures between -20°F (-28.9°C) and 130°F (54.4°C), with line set lengths of up to 100 feet (30.5 m). **CVD1476** - 50°F to 110°F (10°C to 43°C)

Important

QuietQube® ice machines will not function with line sets greater than 100 feet (30.5 m). Do not attempt to go beyond this distance and add refrigerant charge to compensate!

B. LINE SET RISE OR DROP

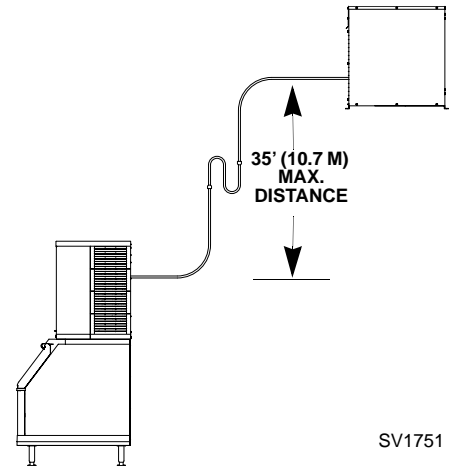

35 feet (10.7 m) Rise: The maximum distance the CVD® condensing unit can be above the ice machine.

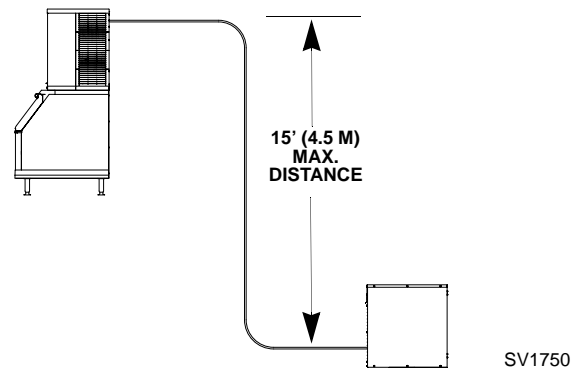

15 feet (4.5 m) Drop: The maximum distance the CVD® condensing unit can be below the ice machine.

C. SUCTION LINE OIL TRAPS

⚠ Caution

Do not form unwanted traps in refrigeration lines. Never coil excess refrigeration tubing.

0 to 20 feet (0 to 6.1 m) Rise: The ice machine head section has one oil trap built in which allows for a maximum condenser rise of 20 feet (6.1 m) without additional traps in the suction line.

21 to 35 feet (6.4 to 10.7 m) Rise: The suction line requires an additional Oil Trap (“S” type) to be installed. Install the trap as close as possible to midpoint between the ice machine head section and CVD condensing unit. S-Trap Kits are available from Manitowoc (refer to chart).

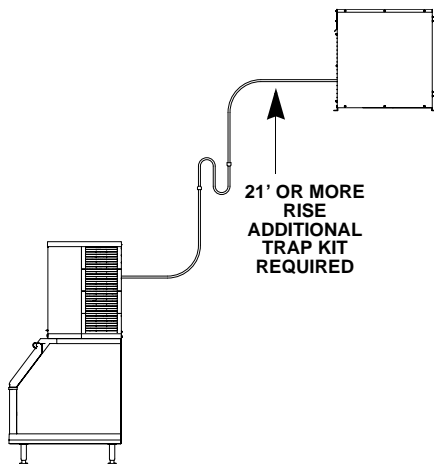

SV1751

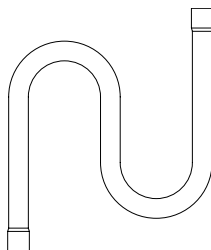

SV1760

Manitowoc S-Trap Kit

| Model | S-Trap Kit Number | Tubing Size |
|--------|-------------------|--------------------|
| Q1400C | K00166 | 3/4 inch (19.1 mm) |

Service Loop

A service loop in the line set permits easy access to the ice machine for cleaning and service.

- **The supplied service loop is an installation requirement. Excess tubing length must be sufficient to allow 180° rotation of the ice machine.**
- A service loop is not considered an oil trap.
- The service loop is not included when calculating length, rise or drop of the tubing run.
- Do not use hard rigid copper for the service loop.

⚠ Caution

If a line set has a rise followed by a drop, another rise cannot be made. Likewise, if a line set has a drop followed by a rise, another drop cannot be made.

Step 3 Lengthening or Reducing Line Set Lengths

⚠ Caution

Do not form unwanted traps in refrigeration lines. Never coil excess refrigeration tubing.

When the line set required shortening or lengthening, do so before connecting the line set to the ice machine head section or the CVD condensing unit.

Step 4 Connecting the line set.

To prevent oxidation of the copper, purge line set and condensing unit with dry nitrogen while brazing.

Connect The Line Set To The Ice Machine Head Section

Warning

The ice machine head section contains refrigerant charge. The ice machine head section contains three (3) refrigeration valves that **must remain closed** until proper installation of the line sets is completed.

The line set can be routed for entry through the top or rear of the ice machine head section.

- Top routing requires the cover to be trimmed.
- Rear routing requires the use of the supplies 90° elbows.

The line set shut off valves at the back of the ice machine must remain closed and be protected from heat during the brazing process. Wrap the valves in a wet rag or other type of heat sink prior to brazing. Cool braze joint with water immediately after brazing to prevent heat migration to the valve.

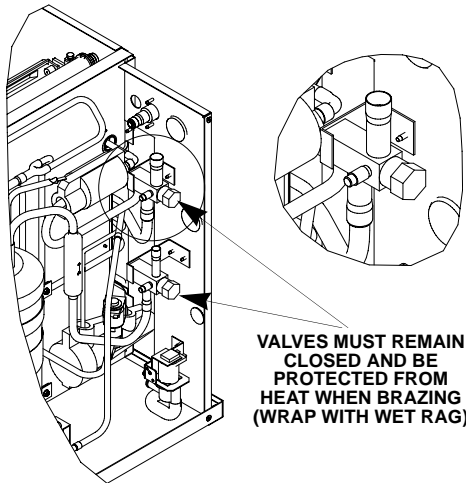

SV1757

Warning

The condensing unit ships from the factory pressurized with a 50/50 mixture of nitrogen/helium. Bleed off pressure from both suction and liquid line access ports prior to cutting into refrigeration lines.

Connect The Line Set To The CVD Condensing Unit

Warning

The condensing unit ships from the factory pressurized with a 50/50 mixture of nitrogen/helium. Bleed off pressure from both suction and liquid line access ports prior to cutting into refrigeration lines.

The compressor oil rapidly absorbs moisture. **Be prepared** to complete line set installation and start your evacuation process in order to minimize the time the compressor is exposed to the atmosphere. (Maximum amount of time the system can be exposed to the atmosphere is 15 minutes).

CVD1475

The line set can be routed for entry through the rear or left side of the condensing unit.

- Remove knockout for preferred location.
- Insert supplied plastic bushings in knockout holes to prevent tubing from contacting sheet metal.
- Use the supplied 90° elbows to route tubing.

CVD1475 and CVD1476

- Cut the tubing ends of the suction and liquid lines and braze the line sets to the condensing unit.

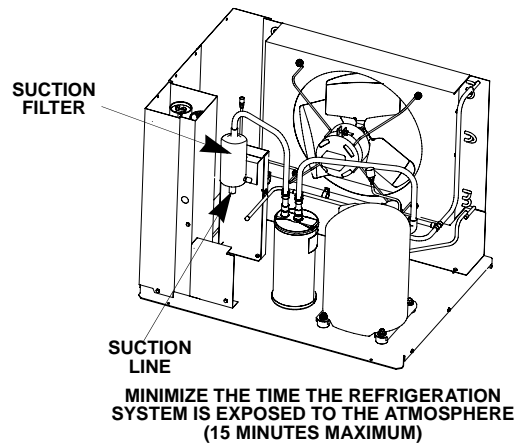

SV2085

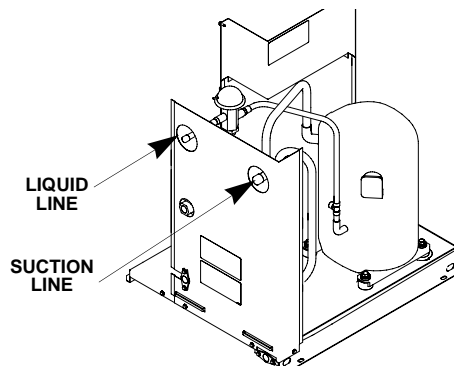

SV3077

Step 5 Pressure Test and Evacuate The Line Set and CVD Condensing Unit

Schrader valve core removal tools that allow for removal and installation of the valve cores without removing manifold gauge set hoses are recommended to decrease the evacuation time.

Leave the line set shut off valves closed (front seated). Pressure test the line sets and CVD condensing unit with 150 psig of dry nitrogen. Add nitrogen at the line set shut off valves located at the back of the ice machine. Complete the pressure test, verify no leaks are present and remove the nitrogen from the system before connecting the vacuum pump. Connect a vacuum pump to both of the line set shut off valves located at the back of the ice machine head section. Evacuate to 500 microns minimum. To completely evacuate the CVD condensing unit, continue the evacuation for 30 minutes after reaching the 500 micron point.

If required, the line set and condensing unit can be evacuated from the schrader valves located in the CVD condensing unit. Schrader valve core removal tools (that allow for putting the cores back in without removing vacuum pump hoses) must be used if evacuating from the condensing unit side.

Pressure test the condensing unit and line set with 150 psig of dry nitrogen. Add nitrogen at the condensing unit Schrader valves. Complete the pressure test, verify no leaks are present and remove the nitrogen from the system before connecting a vacuum pump. Connect the vacuum pump to both the Schrader valves and evacuate to 500 microns minimum.

Disconnect the vacuum pump from the condensing unit access ports prior to proceeding. Open refrigeration system shut off valves.

The suction line, liquid line and receiver service valves are closed during shipment and installation.

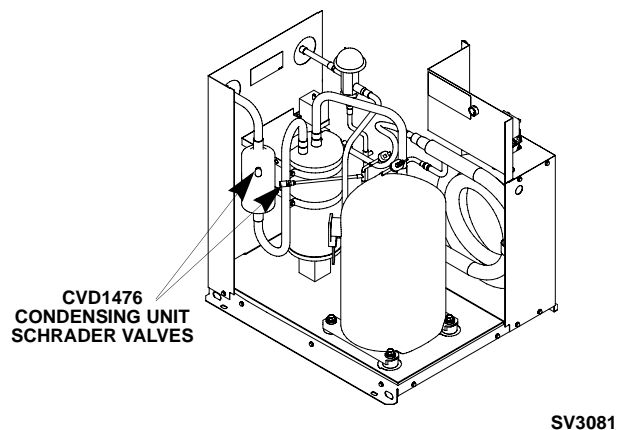
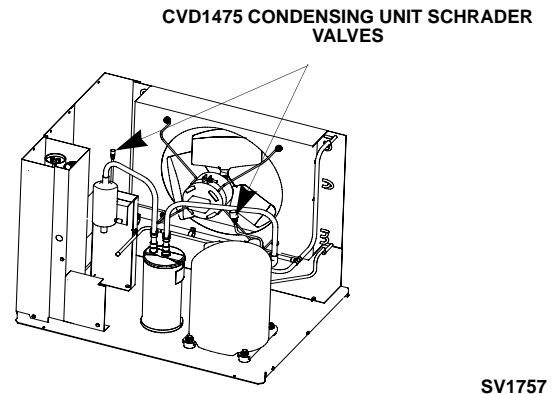
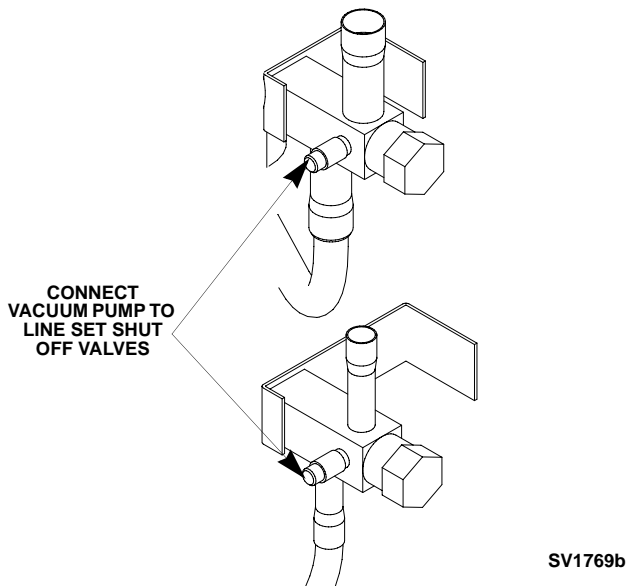

Step 6 Open The Valves Prior To Starting The Ice Machine.

The suction line, liquid line and receiver service valves are closed during shipment and installation. Open the valves prior to starting the ice machine.

- A. Slowly backseat (open-turn counterclockwise) the suction line shut off valve.
- B. Slowly backseat (open-turn counterclockwise) the liquid line shut off valve.
- C. Slowly backseat (open-turn counterclockwise) the receiver service valve.

NOTE: You will not hear refrigerant flow when the valves are opened. Refrigerant will not flow until the toggle switch is placed in the ice position and the liquid line solenoid valve opens.

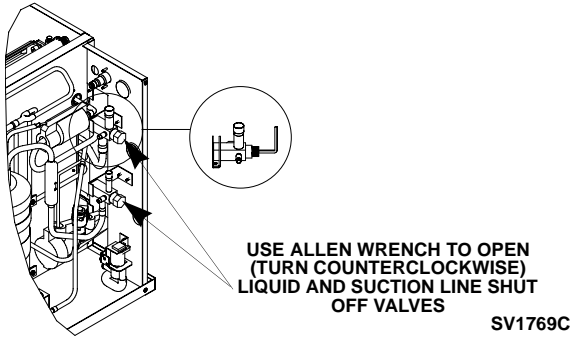

OPEN SUCTION AND LIQUID LINE SHUT OFF VALVES

⚠ Caution

After opening suction, discharge and receiver service valves, refrigerant pressure will not be detected until the toggle switch is placed in the ice position and the harvest solenoid valve energizes.

Important

All refrigeration valve caps must be reinstalled to prevent future refrigeration leaks.

Verify O-ring in schrader valve caps are intact and reinstall on shut off valves to prevent refrigerant leakage. Replace shut off valve access caps and torque to the following specifications.

Torque Value's

| | |
|---------------|----------------|
| Stem | 18-20 ft. lbs. |
| Caps | 12-15 ft. lbs. |
| Schrader Core | 1.5-3 in. lbs. |

Replace cap on receiver service valve and tighten.

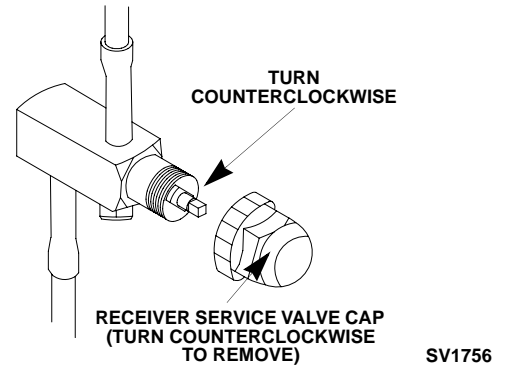

Open Receiver Service Valve

There is a liquid line solenoid valve at the outlet of the receiver; refrigerant will not flow to the condensing unit until the ice machine head section is started. Connect power to both the ice machine head section and the CVD condensing unit. Place the ICE/OFF/CLEAN toggle switch into the ICE position, this will allow refrigerant to enter the line set and condensing unit.

Step 7 Leak Check The Refrigeration System

Leak check the new line set connections at the ice machine head section, condensing unit and S trap as well as all factory joints throughout the entire system. Disconnect power to the CVD condensing unit. Place the ICE/OFF/CLEAN toggle switch into the ICE position. This allows the low side and high side pressures to equalize. Place the ICE/OFF/CLEAN toggle switch in the OFF position. Connect power to the CVD condensing unit and allow system to pump down.

Step 8 Insulation Requirements

To prevent condensation the entire suction line including the shut-off valve must be insulated. All insulation must be airtight and sealed at both ends. Insulate shut-off valves with the supplied preformed insulation.

The following insulation requirements prevent condensation at 90°F (32.2°C) ambient 90% Relative Humidity. If higher humidity is expected, increase insulation thickness.

The entire suction line set, including the suction service valve located on the back of the ice machine requires:

| Suction Line | Liquid Line | Min. Insulation Thickness |
|-----------------------|-----------------------|--|
| 3/4 inch (19.1 mm) | 1/2 inch (12.7 mm) | 1/2" (13mm) Suction Line 1/4" (7mm) Liquid Line |

Important

To prevent condensation the entire suction line including the shut off valve must be insulated. All insulation must be airtight and sealed at both ends. The minimum requirements are for conditions at or below 90% humidity and 90°F (32.2°C) ambient. When higher humidity will be experienced, insulation wall thickness will need to be increased.

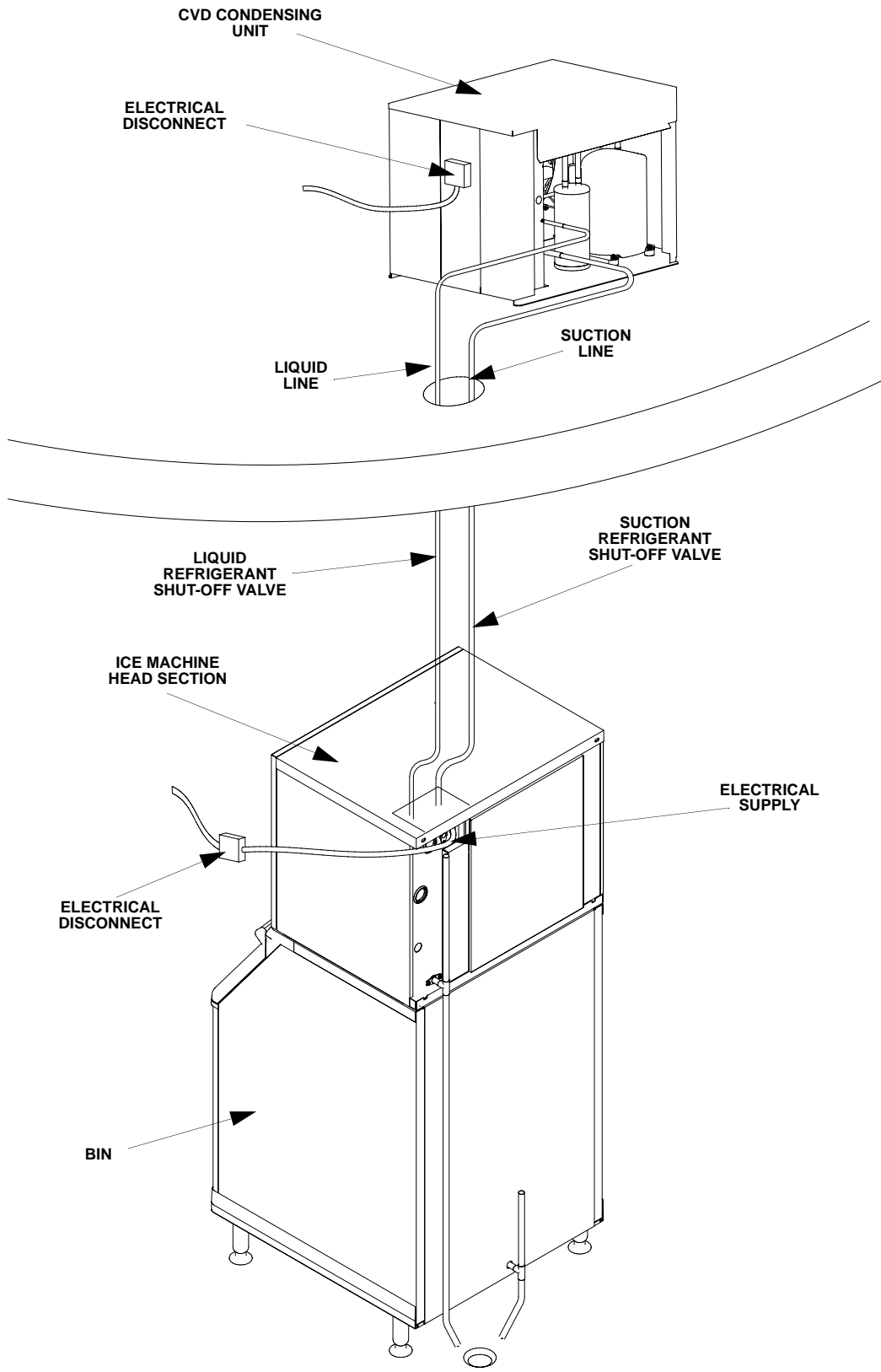

SV1768c

Typical QuietQube System Installation

Installation Checklist

- Is the Ice Machine level?
- Has all of the internal packing been removed?
- Have all of the electrical and water connections been made?
- Has the supply voltage been tested and checked against the rating on the nameplate?
- Is there proper clearance around the ice machine for air circulation?
- Has the ice machine been installed where ambient temperatures will remain in the range of 35° - 110°F (1.7° - 43.3°C)?
- Has the ice machine been installed where the incoming water temperature will remain in the range of 33° - 90°F (0.6° - 32.2°C)?
- Are the ice machine and bin drains separately vented?
- CVD1476 - Is the condensing unit level?
- Are all electrical leads free from contact with refrigeration lines and moving equipment?
- Has the owner/operator been instructed regarding maintenance and the use of Manitowoc Cleaner and Sanitizer?
- Has the warranty registration card been sent to the factory?
- Has the ice machine and bin been sanitized?
- Has the ice machine receiver service valve been opened?
- Does the condenser fan motor(s) operate properly after start-up?
- Have all the refrigeration fittings and joints been leak checked?
- Is the line set routed properly?
- Is a refrigeration oil trap (S-trap) installed if the condenser is installed 21 to 35 feet (6.1 to 10.7m) above the ice machine head?
- Has the CVD® condensing unit been installed to prevent any roofing damage?
- Have the refrigeration lines been insulated and secured properly to prevent vibration?
- Has the remote condensing unit been located where ambient temperatures will remain in the range of -20° to 130°F (-28.9° to 54.4°C)?
- Is the float valve in the OPEN position?
- Is the toggle switch set to ice?
- Is the ice thickness control set correctly?
- CVD1476 Only - Is the drain installed on the condensing unit?

Before Starting the Ice Machine

All Manitowoc ice machines are factory-operated and adjusted before shipment. Normally, new installations do not require any adjustment.

To ensure proper operation, follow the Operational Checks in Section 3 of this manual. Starting the ice machine and completing the Operational Checks are the responsibilities of the owner/operator.

Adjustments and maintenance procedures outlined in this manual are not covered by the warranty.

Warning

Do not operate equipment that has been misused, abused, neglected, damaged, or altered/modified from that of original manufactured specifications.

AuCS® Automatic Cleaning System

This optional accessory monitors ice making cycles and initiates cleaning procedures automatically. The AuCS® accessory can be set to automatically clean or sanitize the ice machine every 2, 4 or 12 weeks. Refer to the AuCS® Installation and Owner/Operator Use and Care Guide for details.

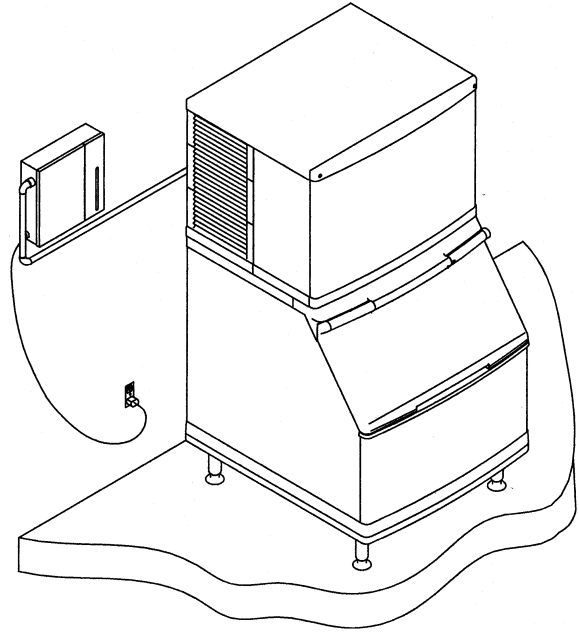

SV1601

THIS PAGE INTENTIONALLY LEFT BLANK

Section 3

Ice Machine Operation

Component Identification

ICE MACHINE HEAD SECTION

Q1400C

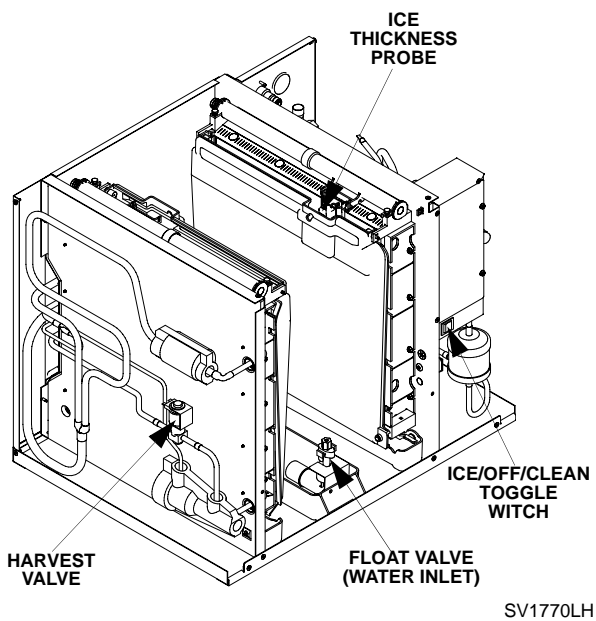
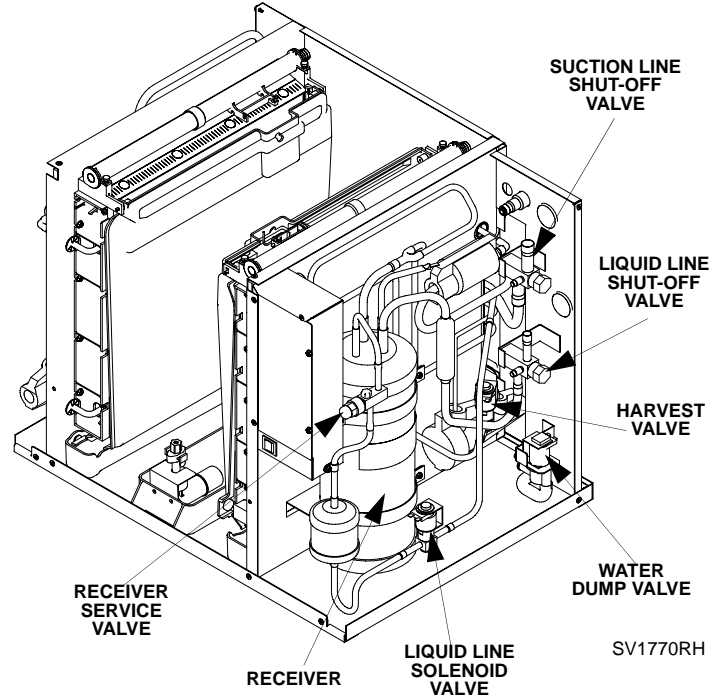
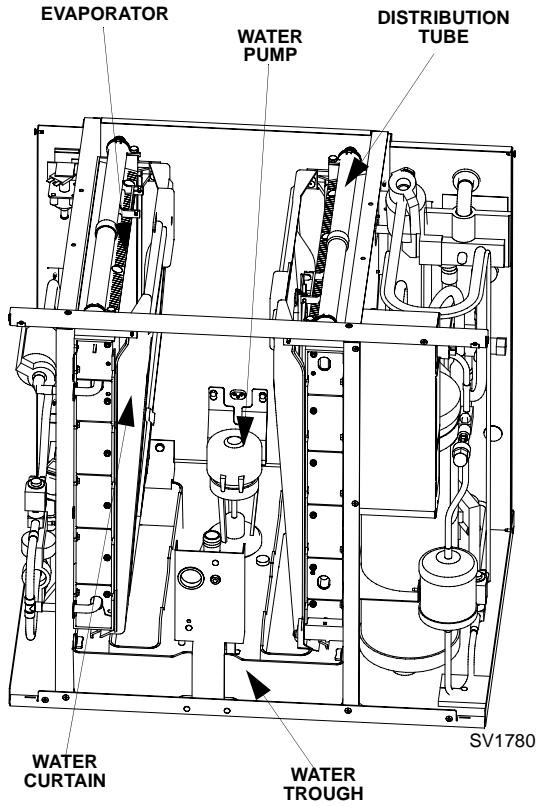

CVD CONDENSING UNIT

CVD1475

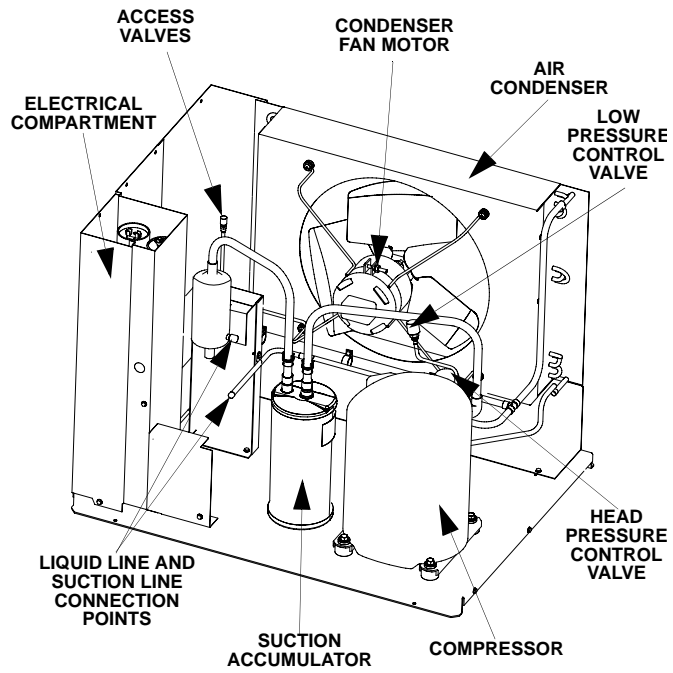

SV2085

CVD1476

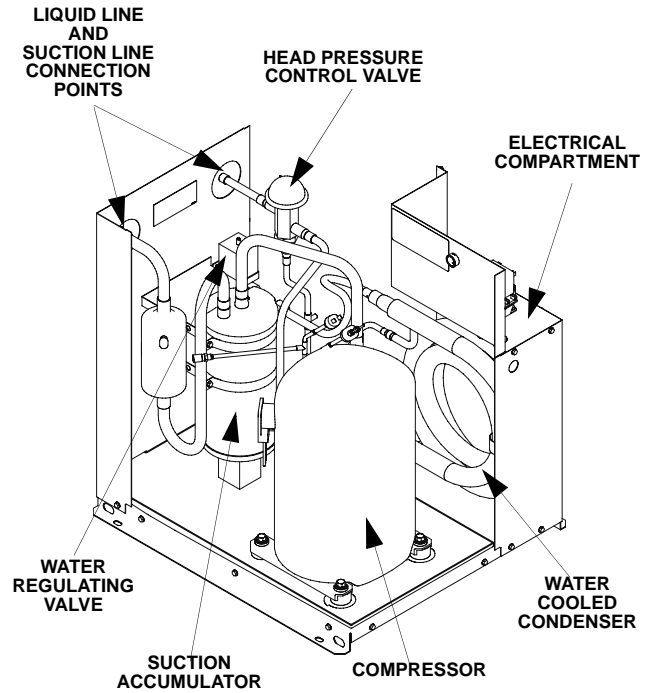

PT1382

Ice Making Sequence of Operation

INITIAL START-UP OR START-UP AFTER AUTOMATIC SHUT-OFF

1. Water Purge

Before the refrigeration system starts, the water pump and water dump solenoid are energized for 45 seconds, to completely purge the ice machine of old water. This feature ensures that the ice making cycle starts with fresh water.

FREEZE SEQUENCE

2. Prechill

Ice Machine Head Section: The liquid line solenoid valve energize after the 45 second water purge and remains on throughout the entire ice making Freeze and Harvest Sequences. The liquid line solenoid is energized for 30 seconds prior to water flow. This allows the refrigeration system to start-up and prechills the evaporator.

CVD Condensing Unit: When the refrigerant pressure is high enough to close the low pressure switch, the contactor coil is energized and the compressor and condenser fan motor (CVD1475 only) start. They are supplied with power throughout the entire Freeze and Harvest Sequences. The fan motor (CVD1475 only) is wired through a fan cycle pressure control, therefore it may cycle on and off.

3. Freeze

The water pump restarts after the 30 second Prechill. An even flow of water is directed across the evaporator and into each cube cell, where it freezes.

When sufficient ice has formed, the water flow (not the ice) contacts the ice thickness probe. After approximately 7 seconds of continual water contact, the Harvest Sequence is initiated. The ice machine cannot initiate a Harvest Sequence until a 6-minute freeze lock has been surpassed.

HARVEST SEQUENCE

4. Water Purge

The water pump continues to run, and the water dump valve energizes for 45 seconds to purge the water in the sump trough. After the 45 second water purge, the water pump and dump valve de-energizes.

Both harvest solenoid valves also open at the beginning of the water purge to divert refrigerant gas into the evaporator.

5. Harvest

The harvest solenoid valves remain open and the refrigerant gas warms each evaporator causing the cubes to slide as a sheet, off the evaporator and into the storage bin. The ice may fall first from either the right or the left evaporator, or both at the same time. The sliding sheet of cubes swings the water curtain out, opening the corresponding bin switch.

The momentary opening and closing of the bin switch de-energizes relay#2 (right) or #3 (left). Opening relay #2 or #3 de-energizes the corresponding harvest solenoid valve for the remainder of the Harvest Sequence. The momentary opening and closing of both bin switches terminates the Harvest Sequence and returns the ice machine to the Freeze Sequence (steps 2-3).

AUTOMATIC SHUT-OFF

6. Automatic Shut-Off

Ice Machine Head Section: When the storage bin is full at the end of a harvest sequence, the sheet of cubes fails to clear either one or both water curtains. After one or both water curtains are held open for 7 seconds, all five relays are held open the ice machine shuts off.

CVD Condensing Unit: When the refrigerant pressure is low enough to open the low-pressure switch, the contactor coil is de-energized and the compressor and condenser fan motor (CVD1475 Only) stop.

The ice machine remains off until enough ice has been removed from the storage bin to allow the ice to fall clear of the water curtain(s). As the water curtain(s) swing back to the operating position, the bin switch re-closes and the ice machine restarts (steps 1 - 2). Both curtains must be closed to start an ice making sequence.

Operational Checks

GENERAL

Manitowoc ice machines are factory-operated and adjusted before shipment. Normally, a newly installed ice machine does not require any adjustment.

To ensure proper operation, always follow the Operational Checks:

- when starting the ice machine for the first time
- after a prolonged out of service period
- after cleaning and sanitizing

NOTE: Routine adjustments and maintenance procedures outlined in this manual are not covered by the warranty.

WATER LEVEL

1. Check the water level while the ice machine is in the freeze mode and the water pump is running. The correct water level is 1/8" - 1/2" (3-12.5 mm)
2. The float valve is factory set for the proper water level. If adjustments are necessary:
 - A. Loosen the two screws on the float valve bracket.
 - B. Raise or lower the float valve assembly as necessary then tighten the screws.
 - C. If further adjustment is required, carefully bend the float arm to achieve the correct water level.

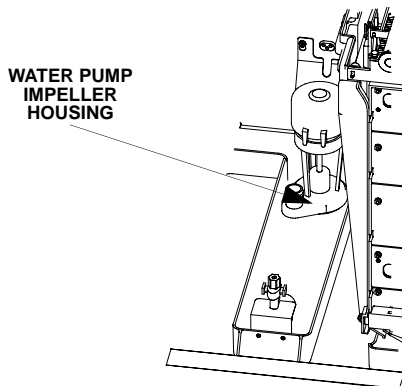

SV1616

WATER FLOAT VALVE CHECK

Before water will flow into the water trough the float valve shut-off must be in the OPEN position.

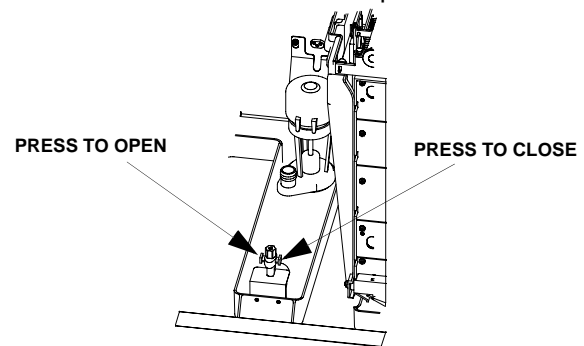

ICE THICKNESS CHECK

After a harvest cycle, inspect the ice cubes in the ice storage bin. The ice thickness probe is factory-set to maintain the ice bridge thickness at 1/8" (3.2 mm).

NOTE: Make sure the water curtain is in place when performing this check. It prevents water from splashing out of the water trough.

1. Inspect the bridge connecting the cubes. It should be about 1/8" (3.2 mm) thick.
2. If adjustment is necessary, turn the ice thickness probe adjustment screw clockwise to increase bridge thickness, counterclockwise to decrease bridge thickness.

NOTE: Turning the adjustment 1/3 of a turn will change the ice thickness about 1/16" (1.5 mm).

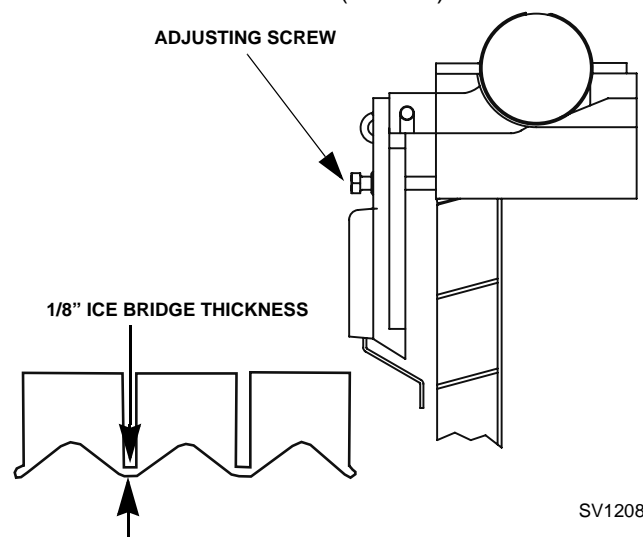

SV1208

Ice Thickness Check

3. Make sure the ice thickness probe wire and the bracket do not restrict movement of the probe.

Section 4 Maintenance

Interior Cleaning and Sanitizing

GENERAL

Clean and sanitize the ice machine every six months for efficient operation. If the ice machine requires more frequent cleaning and sanitizing, consult a qualified service company to test the water quality and recommend appropriate water treatment. The ice machine must be taken apart for cleaning and sanitizing.

 **Caution**

Use only Manitowoc approved Ice Machine Cleaner and Sanitizer for this application (Manitowoc Cleaner part number 94-0546-3 and Manitowoc Sanitizer part number 94-0565-3). It is a violation of Federal law to use these solutions in a manner inconsistent with their labeling. Read and understand all labels printed on bottles before use.

CLEANING PROCEDURE

 **Caution**

Do not mix Cleaner and Sanitizer solutions together. It is a violation of Federal law to use these solutions in a manner inconsistent with their labeling.

 **Warning**

Wear rubber gloves and safety goggles (and/or face shield) when handling ice machine Cleaner or Sanitizer.

Ice machine cleaner is used to remove lime scale and mineral deposits. Ice machine sanitizer disinfects and removes algae and slime.

Step 1 Set the toggle switch to the OFF position after ice falls from the evaporator at the end of a Harvest cycle. Or, set the switch to the OFF position and allow the ice to melt off the evaporator.

 **Caution**

Never use anything to force ice from the evaporator. Damage may result.

Step 2 Remove front cover.

Step 3 Remove all ice from the bin.

Step 4 Place the toggle switch in the CLEAN position. The water will flow through the water dump valve and down the drain. Wait until the water trough refills and water flows over the evaporator, then add the proper amount of ice machine cleaner.

| Model | Amount of Cleaner |
|--------|-------------------|
| Q1400C | 5 ounces (150 ml) |

Step 5 Wait until the clean cycle is complete (approximately 30 minutes) then place the toggle switch in the OFF position and disconnect power to the ice machine (and dispenser when used).

 **Warning**

Disconnect the electric power to the ice machine at the electric service switch box.

Step 6 Remove parts for cleaning.

Warning

Disconnect the electric power to the ice machine at the electric service switch box..

A. Remove the splash shield

- Pull forward on left and right nylatch connectors until disengaged from ice machine (connectors remain attached to splash shield).
- Remove panel from front of ice machine by lifting forward and up.

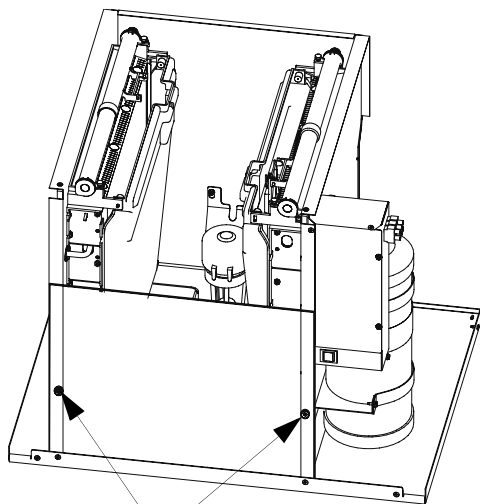

NYLATCH CONNECTORS
PULL FORWARD TO
DISENGAGE

SV1771A

Important

Splash Shield must be reinstalled to prevent water leakage.

B. Remove the water curtain

- Gently flex the curtain in the center and remove it from the right side.
- Slide the left pin out.

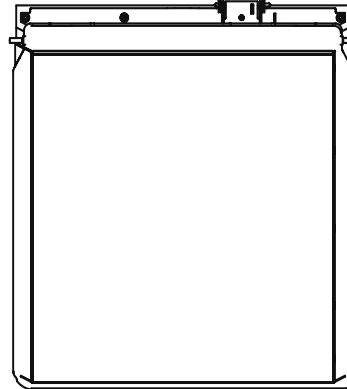

Water Curtain Removal

C. Remove the ice thickness probe

- Compress the hinge pin on the top of the ice thickness probe.

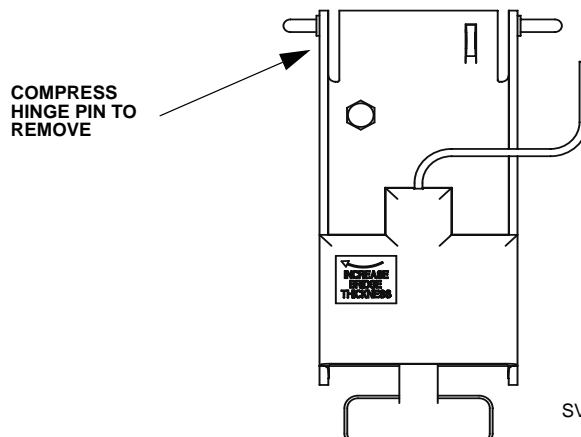

SV3135

Ice Thickness Probe Removal

- Pivot the ice thickness probe to disengage one pin then the other. The ice thickness probe can be cleaned at this point without complete removal. If complete removal is desired, disconnect the ice thickness control wiring from the control board.

D. Remove the water distribution tube

- Remove the clamp from the vinyl water hose on the right side of the distribution tube.

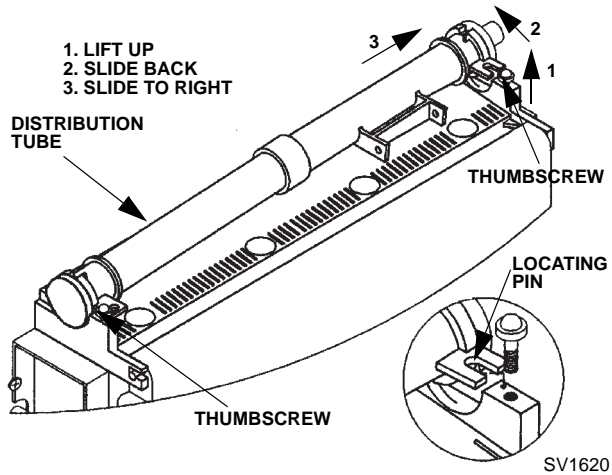

Water Distribution Tube Removal

- Loosen the two thumbscrews which secure the distribution tube.
SU1024YC - Loosen the three thumbscrews, which secure the distribution tube.
- Lift the right side of the distribution tube up, and then rotate it backward and to the right until the left side of the distribution tube disengages the thumbscrew.

⚠ Caution

Do not force this removal. Be sure the locating tab is clear before rotating the distribution tube back.

- Pull the vinyl hose off the distribution tube.
- Disassemble for cleaning:
- Twist both of the inner tube ends until the tabs line up with the keyways.
 - Pull the inner tube ends outward.

E. Remove the float valve

- Turn off the water supply to the ice machine at the water service valve.
- Turn the splash shield counterclockwise one or two turns.

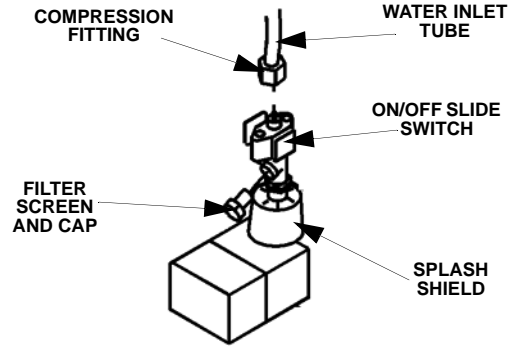

SV1217

Float Valve Removal

- Pull the float valve forward and off the mounting bracket.
- Disconnect the water inlet tube from the float valve at the compression fitting.
- Remove the filter screen and cap for cleaning.

F. Remove the water pump.

- Disconnect the water pump power cord.

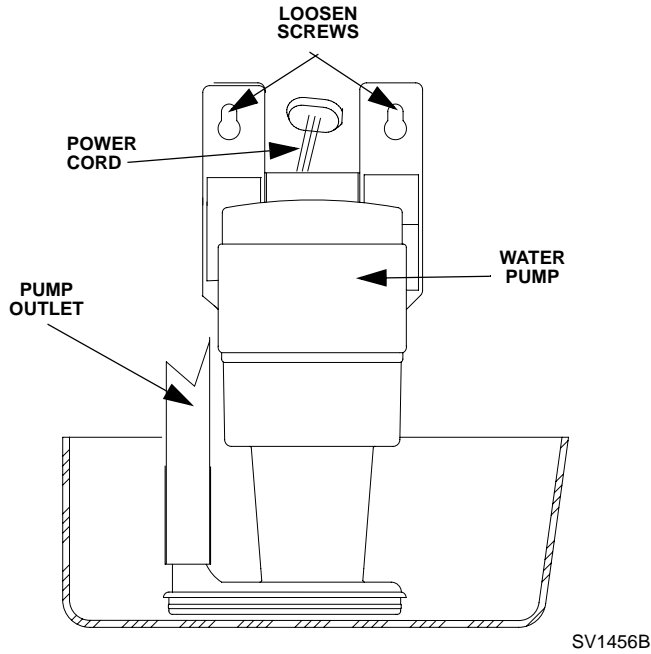

- Disconnect the hose from the pump outlet.
- Loosen the screws securing the pump mounting bracket to the bulkhead.
- Lift the pump and bracket assembly off the screws.
- Remove water pump assembly from ice machine. Do not soak the water pump motor in cleaner or sanitizer solution

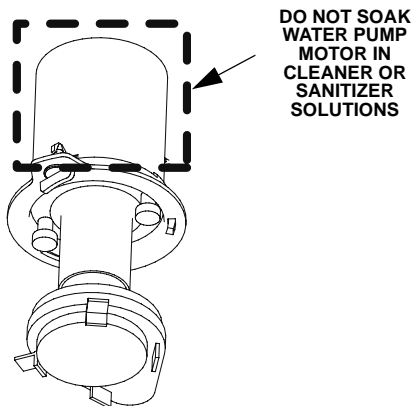

G. Remove the water trough

- Remove the quarter turn fasteners (turn counterclockwise) securing the trough in place.
- Lift up and forward on the front of the water trough while allowing the rear of the water trough to drop.
- Remove the water trough from the ice machine.

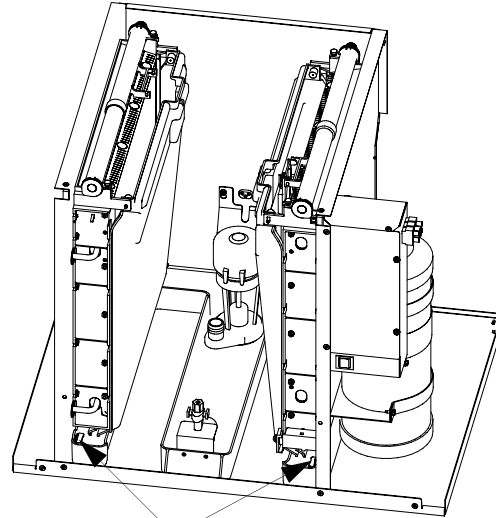

Step 7 Mix a solution of cleaner and warm water. Depending upon the amount of mineral buildup, a larger quantity of solution may be required. Use the ratio in the table below to mix enough solution to thoroughly clean all parts.

| Solution Type | Water | Mixed With |
|---------------|--------------|------------------------|
| Cleaner | 1 gal. (4 l) | 16 oz (500 ml) cleaner |

Step 8 Use 1/2 of the cleaner/water mixture to clean all components. The cleaner solution will foam when it contacts lime scale and mineral deposits; once the foaming stops use a soft-bristle nylon brush, sponge or cloth (NOT a wire brush) to carefully clean the parts. Soak parts for 5 minutes (15 - 20 minutes for heavily scaled parts). Rinse all components with clean water.

Step 9 While components are soaking, use 1/2 of the cleaner/water solution to clean all foodzone surfaces of the ice machine and bin (or dispenser). Use a nylon brush or cloth to thoroughly clean the following ice machine areas:

- Side walls
- Evaporator plastic parts - including top, bottom, and sides
- Bin or dispenser

Rinse all areas thoroughly with clean water.

Step 10 Mix a solution of sanitizer and warm water.

| Solution Type | Water | Mixed With |
|---------------|---------------|-------------------------|
| Sanitizer | 6 gal. (23 l) | 4 oz (120 ml) sanitizer |

Step 11 Use 1/2 of the sanitizer/water solution to sanitize all removed components. Use a cloth or sponge to liberally apply the solution to all surfaces of the removed parts or soak the removed parts in the sanitizer/water solution. Do not rinse parts after sanitizing.

Step 12 Use 1/2 of the sanitizer/water solution to sanitize all foodzone surfaces of the ice machine and bin (or dispenser). Use a cloth or sponge to liberally apply the solution. When sanitizing, pay particular attention to the following areas:

- Side walls
- Evaporator plastic parts - including top, bottom and sides
- Bin or dispenser

Do not rinse the sanitized areas.

Step 13 Replace all removed components.

Step 14 Reapply power to the ice machine and place the toggle switch in the CLEAN position.

Step 15 Wait about two minutes or until water starts to flow over the evaporator. Add the proper amount of Manitowoc Ice Machine Sanitizer to the water trough by pouring between the water curtain and evaporator.

| Model | Amount of Sanitizer |
|--------|---------------------|
| Q1400C | 5 ounces (150 ml) |

Step 16 The ice machine will stop after the sanitize cycle (approximately 30 minutes). Place the toggle switch in the OFF position and disconnect power to the ice machine.

 **Warning**

Disconnect the electric power to the ice machine at the electric service switch box..

Step 17 Repeat step 6.

Step 18 Mix a solution of sanitizer and warm water.

| Solution Type | Water | Mixed With |
|---------------|---------------|-------------------------|
| Sanitizer | 6 gal. (23 l) | 4 oz (120 ml) sanitizer |

Step 19 Use 1/2 of the sanitizer/water solution to sanitize all removed components. Use a cloth or sponge to liberally apply the solution to all surfaces of the removed parts or soak the removed parts in the sanitizer/water solution. Do not rinse parts after sanitizing.

Step 20 Use 1/2 of the sanitizer/water solution to sanitize all foodzone surfaces of the ice machine and bin (or dispenser). Use a cloth or sponge to liberally apply the solution. When sanitizing, pay particular attention to the following areas:

- Side walls
- Evaporator plastic parts - including top, bottom and sides
- Bin or dispenser

Do not rinse the sanitized areas.

Step 21 Install the removed parts, restore power and place the toggle switch in the ICE position.

ADDITIONAL COMPONENT REMOVAL

The following components may be removed for easier access in some installations or they may need to be removed and cleaned to correct an operational problem.

Water Dump Valve

The water dump valve normally does not require removal for cleaning. To determine if removal is necessary:

1. Set the toggle switch to ICE.
2. Verify the water trough fills with water at the beginning of the freeze cycle.
3. While the ice machine is in the freeze mode, check the drain to determine if the dump valve is leaking. If there is water exiting the ice machine through the drain during the freeze cycle the dump valve is leaking.
 - A. If the dump valve is leaking, remove, disassemble and clean it.
 - B. If the dump valve is not leaking, do not remove it. Instead, follow the "Ice Machine Cleaning Procedure".

Follow this procedure to remove the dump valve.

⚠ Warning

Disconnect the electric power to the ice machine at the electric service switch box and turn off the water supply before proceeding.

1. Leaving the wires attached, twist coil and rotate it counter-clockwise 1/4 turn.
2. Lift the coil assembly off the valve body.
3. Remove the spring, plunger, and nylon gasket from the valve body.

NOTE: At this point, the water dump valve can easily be cleaned. If complete removal is desired, continue with step 4.

NOTE: During cleaning, do not stretch or damage the spring.

4. Remove the tubing from the dump valve by twisting the clamps off.
5. Twist the valve body to remove from mounting bracket.

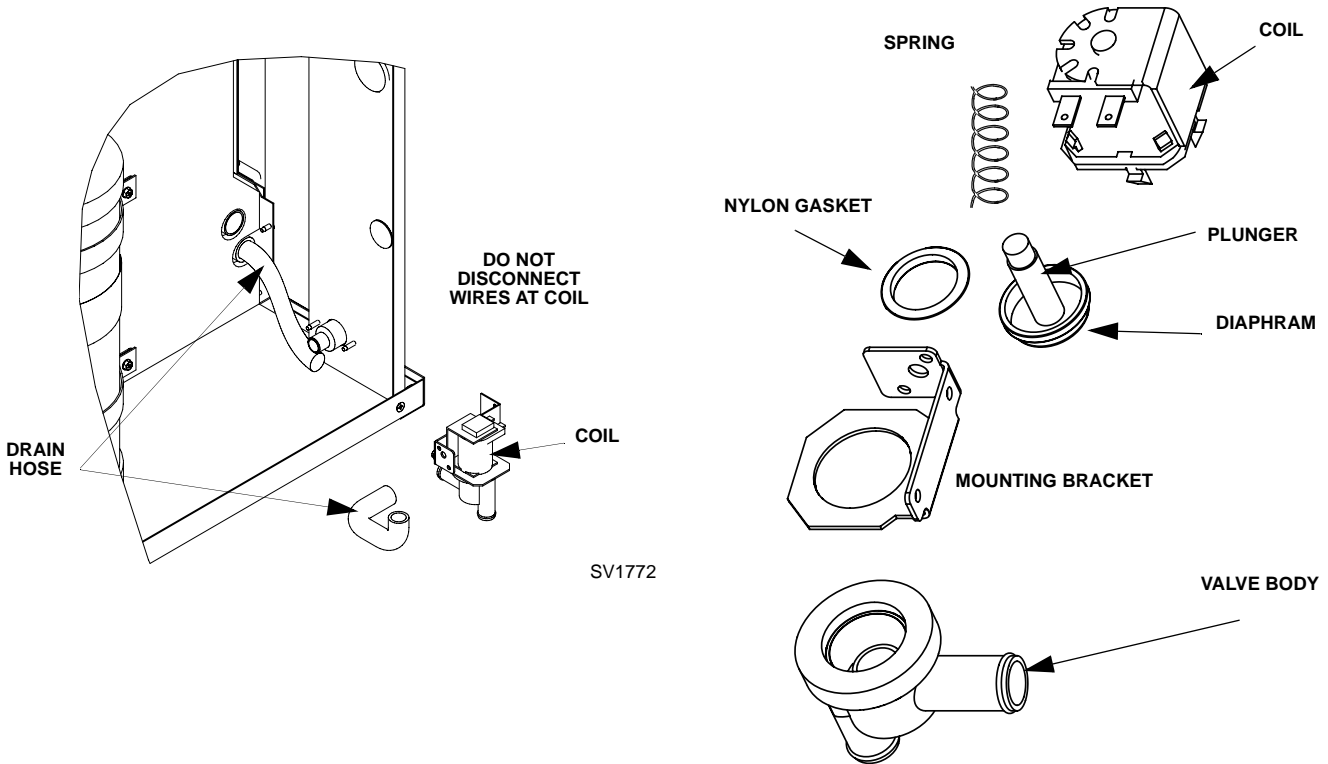

SV1772

Dump Valve Disassembly

Ice Machine Inspection

Check all water fittings and lines for leaks. Also, make sure the refrigeration tubing is not rubbing or vibrating against other tubing, panels, etc.

Do not put anything (boxes, etc.) on the sides or back of the ice machine. There must be adequate airflow through and around the ice machine to maximize ice production and ensure long component life.

Exterior Cleaning

Clean the area around the ice machine as often as necessary to maintain cleanliness and efficient operation. Use cleaners designed for use with stainless steel products.

Sponge any dust and dirt off the outside of the ice machine with mild soap and water. Wipe dry with a clean, soft cloth.

Heavy stains should be removed with stainless steel wool. Never use plain steel wool or abrasive pads. They will scratch the panels.

Cleaning the Condenser

GENERAL

Warning

Disconnect electric power to the ice machine head section and the remote condensing unit at the electric service switches before cleaning the condenser.

A dirty condenser restricts airflow, resulting in excessively high operating temperatures. This reduces ice production and shortens component life. Clean the condenser at least every six months.

Warning

The condenser fins are sharp. Use care when cleaning them.

Shine a flashlight through the condenser to check for dirt between the fins. To remove dirt:

- A. Blow compressed air or rinse with water from the inside out (opposite direction of airflow). Be careful not to bend the fan blades.
- B. Use a commercial condenser coil cleaner if required to remove dirt/grease. Follow the directions and cautions supplied with the cleaner.
- C. Straighten any bent condenser fins with a fin comb.

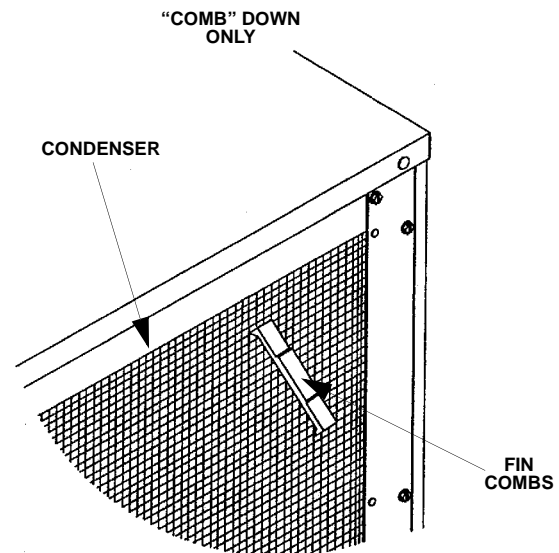

SV1515

Straighten Bent Condenser Fins

**Water-Cooled Condenser
and Water Regulating Valve CVD1476 Only**

Symptoms of restrictions in the condenser water circuit include:

- Low ice production
- High water consumption
- High operating temperatures
- High operating pressures

If the ice machine is experiencing any of these symptoms, the water-cooled condenser and water regulating valve may require cleaning due to scale build-up.

Because the cleaning procedures require special pumps and cleaning solutions, qualified maintenance or service personnel must perform them.

Removal from Service/Winterization

GENERAL

Special precautions must be taken if the ice machine is to be removed from service for an extended period of time or exposed to ambient temperatures of 32°F (0°C) or below.

Caution

If water is allowed to remain in the ice machine in freezing temperatures, severe damage to some components could result. Damage of this nature is not covered by the warranty.

Follow the applicable procedure below.

1. Move the ICE/OFF/CLEAN switch to OFF.
2. Disconnect the electric power at the circuit breaker or the electric service switch.
3. Turn off the water supply.
4. Remove the water from the water trough.
5. Disconnect and drain the incoming ice-making water line at the rear of the ice machine.
6. Energize the ice machine and wait one minute for the water inlet valve to open.
7. Blow compressed air in both the incoming water and the drain openings in the rear of the ice machine until no more water comes out of the inlet water lines or the drain.
8. Make sure water is not trapped in any of the water lines, drain lines, distribution tubes, etc.
9. "Frontseat" (shut off) the receiver service valves. Hang a tag on the switch as a reminder to open the valves before restarting.

CVD 1476 WATER COOLED CONDENSING UNIT

1. Place the ice machine toggle switch into the OFF position.
2. "Front seat" (shut off) the receiver service valve. Hang a tag on the switch as a reminder to open the valve before restarting.
3. Perform steps 1-6 in previous column.
4. Disconnect the incoming water and drain lines from the water-cooled condenser.
5. Insert a large screwdriver between the bottom spring coils of the water regulating valve. Pry upward to open the valve.

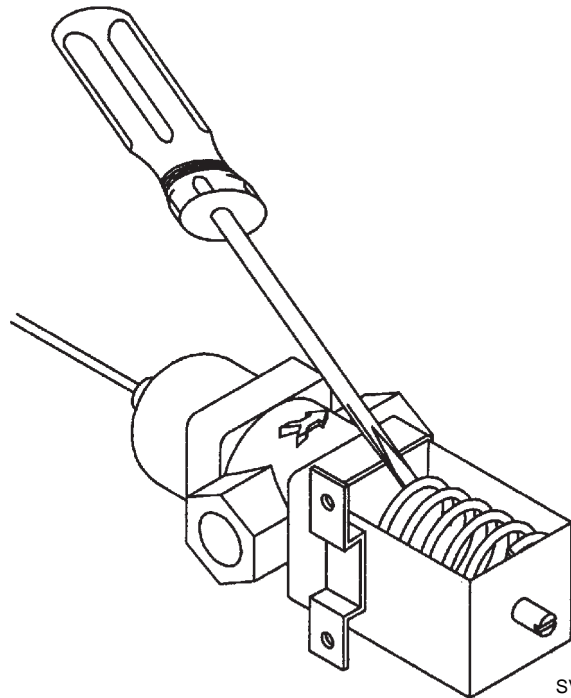

SV1624

Pry Open the Water Regulating Valve

6. Hold the valve open and blow compressed air through the condenser until no water remains.

Section 5 Before Calling For Service

Checklist

If a problem arises during operation of your ice machine, follow the checklist below before calling service. Routine adjustments and maintenance procedures are not covered by the warranty.

| Problem | Possible Cause | To Correct |
|---|--|--|
| Ice machine does not operate. | No electrical power to the ice machine and/or condensing unit. | Replace the fuse/reset the breaker/turn on the main switch. |
| | High pressure cutout tripping. | Clean condenser coil. (See Section 4) |
| | ICE/OFF/CLEAN toggle switch set improperly. | Move the toggle switch to the ICE position. |
| | Water curtain stuck open. | Water curtain must be installed and swinging freely. (See Section 4) |
| | Remote receiver service valve and/or Liquid/suction line shut off valves are closed. | Open the valve(s). (See Section 2) |
| Ice machine stops, and can be restarted by moving the toggle switch to OFF and back to ICE. | Safety limit feature stopping the ice machine. | Refer to "Safety Limit Feature" on the next page. |
| Ice machine does not release ice or is slow to harvest. | Ice machine is dirty. | Clean and sanitize the ice machine. (See Section 4) |
| | Ice machine is not level. | Level the ice machine. (See Section 2) |
| | Low air temperature around ice machine head section. | Air temperature must be at least 35°F (1.6°C). |
| | CVD1476 - Water regulating valve incorrectly adjusted or will not close. | Check for water at condenser water drain outlet. Contact a qualified service company to adjust/replace valve. |
| | CVD1475 - Fan cycling control does not de-energize condenser fan motor. | Verify pressure is below cut-out setpoint, replace fan cycling control. |
| Ice machine does not cycle into harvest mode. | The six-minute freeze time lock-in has not expired yet. | Wait for the freeze lock-in to expire. |
| | Ice thickness probe is dirty. | Clean and sanitize the ice machine. (See Section 4) |
| | Ice thickness probe is disconnected. | Connect the wire. |
| | Ice thickness probe is out of adjustment. | Adjust the ice thickness probe. (See Section 3) |
| | Uneven ice fill (thin at the top of evaporator). | Verify sufficient water level in sump trough. Contact a qualified service company to check refrigeration system. |
| Ice quality is poor (soft or not clear). | Poor incoming water quality. | Contact a qualified service company to test the quality of the incoming water and make appropriate filter recommendations. |
| | Water filtration is poor. | Replace the filter. |
| | Ice machine is dirty. | Clean and sanitize the ice machine. (See Section 4) |
| | Water dump valve is not working. | Disassemble and clean the water dump valve. (See Section 4) |
| | Water softener is working improperly (if applicable). | Repair the water softener. |

| Problem | Possible Cause | To Correct |
|--|---|---|
| Ice machine produces shallow or incomplete cubes, or the ice fill pattern on the evaporator is incomplete. | Ice thickness probe is out of adjustment. | Adjust the ice thickness probe. (See Section 4) |
| | Water trough level is too high or too low. | Check the water level probe for damage. (See Section 3) |
| | Water inlet valve filter screen is dirty. | Remove the water inlet valve and clean the filter screen. (See Section 4) |
| | Water filtration is poor. | Replace is filter. |
| | Hot incoming water. | Connect the ice machine to a cold water supply. (See Section 2) |
| | Incorrect incoming water pressure. | Water pressure must be 20-80 psi (137.9 - 551.5 kPA) |
| | Ice machine head section is not level. | Level the ice machine head section. (See Section 2) |
| Low ice capacity. | Water float valve filter screen is dirty. | Clean the filter screen. (See Section 4) |
| | Incoming water supply is shut off. | Open the water service valve. |
| | Water float valve stuck open or leaking. | Clean or replace the water float valve.(See Section 4) |
| | The condenser is dirty. | Clean the condenser. (See Section 4) |
| | High air temperature around condenser unit. | Air temperature must not exceed CVD1475 - 130°F (54.4°C) CVD1476 - 110°F (43.3°C) |

Safety Limit Feature

In addition to the standard safety controls, such as the high pressure cutout, your Manitowoc ice machine features built-in safety limits which will stop the ice machine if conditions arise which could cause a major component failure.

Before calling for service, re-start the ice machine using the following procedure:

1. Move the ICE/OFF/CLEAN switch to OFF and then back to ICE.
 - A. If the safety limit feature has stopped the ice machine, it will restart after a short delay. Proceed to step 2.
 - B. If the ice machine does not restart, see “Ice machine does not operate” on the previous page.
2. Allow the ice machine to run to determine if the condition is recurring.
 - A. If the ice machine stops again, the condition has recurred. Call for service.
 - B. If the ice machine continues to run, the condition has corrected itself. Allow the ice machine to continue running.

THIS PAGE INTENTIONALLY LEFT BLANK

THIS PAGE INTENTIONALLY LEFT BLANK

EC DECLARATION OF CONFORMITY

We hereby declare that our products, ice machines and Multiplex refrigeration equipment comply with all the essential requirements of the listed EC - directives.

Manufacturer:

*Manitowoc Ice, Inc.
2110 S. 26th Street, P.O. Box 1720
Manitowoc, Wisconsin 54221-1720 USA*

European Distributor:

Representative of Manitowoc Ice, Inc.:

Engineering Manager, (Printed name)

Representative of European Distributor:

Signature

Model and Serial No.

Applied EC Directives:

Applied Standards:

EN60335-1 Safety of household and similar electrical appliances
EN60335-2-24 Particular requirements refrigerators, food freezers and ice makers

EN55014 Electrical Motor Operated Appliances (Emissions)
EN55014 Electro Magnetic Compatibility (Immunity)
EN378 -1 to -4 Refrigeration Plants

Low Voltage 73/23/EEC
EMC 89/336/EEC
Pressure Equipment 97/23/EC



8201043
08/25/03

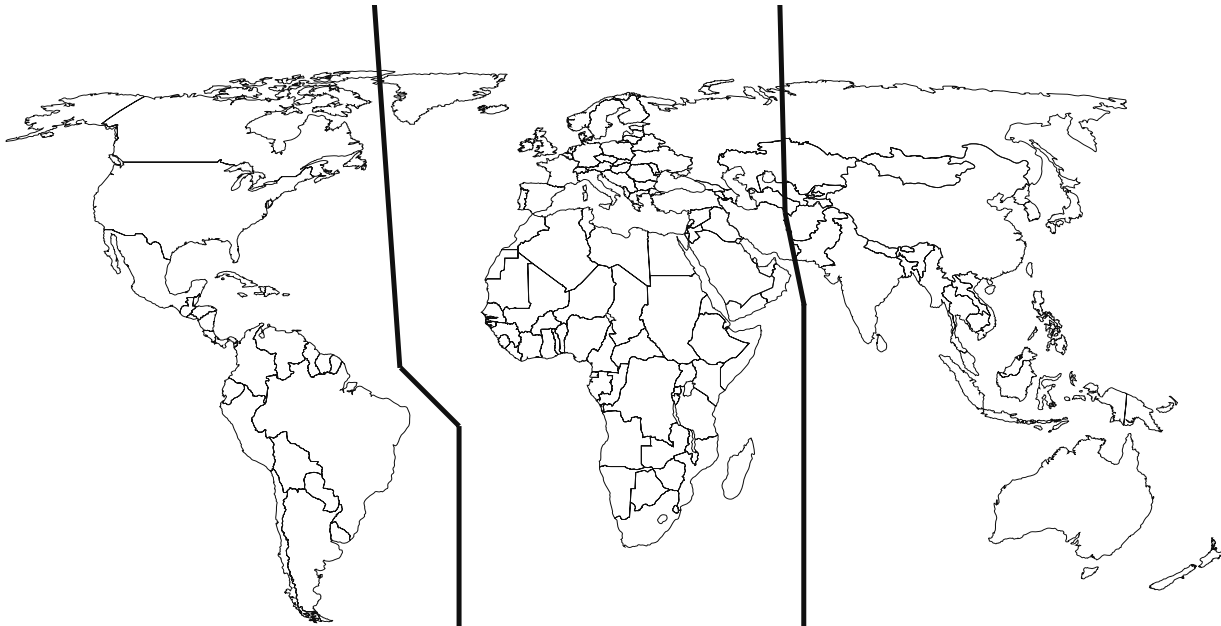

Manitowoc Ice, Inc.
2110 South 26th Street
P.O. Box 1720
Manitowoc, WI 54221-1720
Phone: (920) 682-0161
Service Fax: (920) 683-7585
Web Site - www.manitowocice.com

Manitowoc Foodservice International
S.A.S.
18 Chemin de Charbonnières
F-69132 Ecully Cedex
Téléphone : +33 (0)4 72 18 22 50
Fax : +33 (0)4 72 18 22 60
Site Web – www.manitowocice.com

Manitowoc (China) International Refrigeration
Company, LTD
No. 151 Jiam Ye Road
Hangzhou Hi-Tech Industry Development Zone
(Bin Jiang)
Hangzhou, Zhejiang 310052
P.R. China
Telephone: 86-571-86888688
Service Fax: 86-571-86622707
Web Site – www.manitowoc.com.cn

MANITOWOC ICE, INC.
Web Site - www.manitowocice.com

© 2006 Manitowoc Ice, Inc.