



**QM20/QM30/QM45  
SM50  
Q130/Q170/Q210/Q270  
Undercounter  
Ice Machines**

**Technician's  
Handbook**

This manual is updated as new information and models are released. Visit our website for the latest manual.  
[www.manitowocice.com](http://www.manitowocice.com)

***America's #1 Selling Ice Machine***

Part Number 80-0111-9 6/11



## Safety Notices

As you work on Manitowoc equipment, be sure to pay close attention to the safety notices in this handbook. Disregarding the notices may lead to serious injury and/or damage to the equipment.

Throughout this handbook, you will see the following types of safety notices:



### **Warning**

Text in a Warning box alerts you to a potential personal injury situation. Be sure to read the Warning statement before proceeding, and work carefully.



### **Caution**

Text in a Caution box alerts you to a situation in which you could damage the equipment. Be sure to read the Caution statement before proceeding, and work carefully.

## Procedural Notices

As you work on Manitowoc equipment, be sure to read the procedural notices in this handbook. These notices supply helpful information which may assist you as you work.

Throughout this handbook, you will see the following types of procedural notices:

### **Important**

Text in an Important box provides you with information that may help you perform a procedure more efficiently. Disregarding this information will not cause damage or injury, but it may slow you down as you work.

**NOTE:** Text set off as a Note provides you with simple, but useful, extra information about the procedure you are performing.

## Read These Before Proceeding:

### **Caution**

Proper installation, care and maintenance are essential for maximum performance and trouble-free operation of your Manitowoc equipment. If you encounter problems not covered by this handbook, do not proceed, contact Manitowoc Foodservice Group. We will be happy to provide assistance.

### **Important**

Routine adjustments and maintenance procedures outlined in this handbook are not covered by the warranty.

### **Warning**

#### **PERSONAL INJURY POTENTIAL**

Do not operate equipment that has been misused, abused, neglected, damaged, or altered/modified from that of original manufactured specifications.

### **Warning**

#### **POTENTIAL PERSONAL INJURY SITUATION**

This ice machine contains refrigerant charge. Installation and brazing of the line sets must be performed by a properly trained refrigeration technician aware of the **Dangers of dealing with refrigerant** charged equipment. The technician must also be US Government Environmental Protection Agency (EPA) certified in proper refrigerant handling and servicing procedures.

We reserve the right to make product improvements at any time. Specifications and design are subject to change without notice.

# Table of Contents

---

## GENERAL INFORMATION

<b>Model Numbers</b> .....	11
<b>How to Read a Model Number</b> .....	12
<b>Accessories</b> .....	12
Bin Caster .....	12
Manitowoc Cleaner and Sanitizer .....	12
<b>Model/Serial Number Location</b> .....	14
Q130/Q170/Q210/Q270 .....	14
QM20/QM30 .....	15
QM45 .....	15
<b>Ice Machine Warranty Information</b> .....	17
Owner Warranty Registration Card .....	17
Commercial Warranty Coverage .....	17
Residential Warranty Coverage .....	20

## INSTALLATION

<b>Location of Ice Machine</b> .....	23
<b>Ice Machine Clearance Requirements</b> .....	24
<b>Ice Machine Heat of Rejection</b> .....	24
<b>Leveling the Ice Machine</b> .....	25
QM45/Q130/Q170/Q210/Q270 .....	25
SM50/QM20/QM30 .....	26
<b>Electrical Requirements</b> .....	27
Voltage .....	27
<b>Electrical Specifications</b> .....	28
<b>Water Service/Drains</b> .....	31
Water Supply .....	31
Water Inlet Lines .....	31
Drain Connections .....	31
Cooling Tower Applications .....	32

## COMPONENT IDENTIFICATION

<b>QM45/Q130/Q170/Q210/Q270</b> .....	37
<b>QM20/QM30</b> .....	39
<b>SM50</b> .....	41

## MAINTENANCE

<b>Ice Machine Inspection</b> .....	43
<b>Exterior Cleaning</b> .....	43

<b>Cleaning the Condenser</b> .....	43
Air-cooled Condenser .....	44
Water-cooled Condenser and Water Regulating Valve .....	44
<b>QM45/Q130/Q170/Q210/Q270</b> .....	45
Interior Cleaning and Sanitizing .....	45
<b>QM20/QM30</b> .....	60
Cleaning and Sanitizing Procedure ..	60
<b>SM50</b> .....	67
Cleaning Procedure .....	67
Sanitizing Procedure .....	68
Removal of Parts for Cleaning and Sanitizing .....	69
<b>Removal from Service/Winterization</b> ...	77
General .....	77
Air-cooled Ice Machines .....	77
Water-cooled Ice Machines .....	78

## OPERATION

<b>QM45/Q130/Q170/Q210/Q270</b> .....	79
Initial Start-up or Start-up After Automatic Shut-off .....	79
Freeze Sequence .....	79
Harvest Sequence .....	80
Automatic Shut-off .....	80
Energized Parts Chart .....	81
<b>QM20/QM30</b> .....	83
Initial Start-up or Start-up After Automatic Shut-off .....	83
Freeze Sequence .....	83
Harvest Sequence .....	84
Automatic Shut-off .....	84
Energized Parts Chart .....	85
<b>SM50</b> .....	86
Initial Start-up or Start-up After Automatic Shut-off .....	86
Energized Parts Chart .....	88
<b>Operational Checks</b> .....	89
QM45/Q130/Q170/Q210/Q270 .....	89
QM20/QM30 .....	92
SM50 .....	95

## TROUBLESHOOTING

<b>QM45/Q130/Q170/Q210/Q270</b>	99
Diagnosing an Ice Machine that Will Not Run	99
Diagnosing Ice Thickness Control Circuitry	100
Ice Production Check	103
Installation and Visual Inspection Checklist	104
Water System Checklist	105
Ice Formation Pattern	106
Safety Limit Feature	108
Analyzing Discharge Pressure	115
Analyzing Suction Pressure	117
Hot Gas Valve	121
Comparing Evaporator Inlet/Outlet Temperatures	125
Discharge Line Temperature Analysis	126
Refrigeration Component Diagnostic Chart	128
Final Analysis	130
Refrigeration Component Diagnostic Chart	131
<b>QM20/QM30</b>	134
Diagnosing an Ice Machine that Will Not Run	134
Refrigeration Diagnostics	135
Ice Formation Pattern	137
<b>QM45</b>	139
Electrical	139
Refrigeration Diagnostics	140
Flooding Expansion Valve	143
Starving Expansion Valve/ Low Refrigerant Charge	143
Overcharged System	143
<b>SM50</b>	144
Diagnosing an Ice Machine that Will Not Run	144
Ice Machine Will Not Harvest	145
Ice Quality Is Poor — Cubes are Shallow, Incomplete or White	146

Freeze Cycle Is Long, Low Ice Production . . . . .	147
Ice Machine Runs and No Ice Is Produced . . . . .	148
Analyzing Discharge Pressure . . . . .	149
Discharge Pressure High Checklist . .	150
Freeze Cycle Discharge Pressure Low Checklist . . . . .	150
Analyzing Suction Pressure . . . . .	151
Hot Gas Valve . . . . .	154

## COMPONENT CHECK PROCEDURES

<b>Main Fuse</b> . . . . .	159
Function . . . . .	159
Specifications . . . . .	159
Check Procedure . . . . .	159
<b>Bin Switch</b> . . . . .	160
QM45/Q130/Q170/Q210/Q270 . . . . .	160
<b>Bin Thermostat</b> . . . . .	164
QM20/QM30 . . . . .	164
SM50 . . . . .	166
<b>Liquid Line Thermistor</b> . . . . .	169
QM20/QM30/SM50 . . . . .	169
<b>Diagnosing Start Components</b> . . . . .	171
Capacitor . . . . .	171
Relay . . . . .	171
<b>ON/OFF/WASH Toggle Switch</b> . . . . .	172
Function . . . . .	172
Specifications . . . . .	172
Check Procedure . . . . .	172
QM45/Q130/Q170/Q210/Q270 . . . . .	173
QM20/QM30 . . . . .	173
<b>Ice Thickness Probe</b> . . . . .	174
QM45/Q130/Q170/Q210/Q270 . . . . .	174
Ice Thickness Check . . . . .	175
<b>Compressor Electrical Diagnostics</b> . . . . .	176
Check Resistance (Ohm) Values . . . . .	176
Single Phase Compressors . . . . .	176
Check Motor Windings to Ground . . .	176
Compressor Drawing Locked Rotor . .	177
Compressor Drawing High Amps . . . .	177
<b>Fan Cycle Control</b> . . . . .	178
QM45/Q130/Q170/Q210/Q270 . . . . .	178



<b>High Pressure Cutout (HPCO) Control</b>	179
QM45/Q130/Q170/Q210/Q270	179
<b>Filter-Driers</b>	180
Liquid Line Filter Drier	180
<b>Refrigerant Recovery/Evacuation</b>	181
Definitions	181
Refrigerant Re-use Policy	182
Recovery and Recharging	184
<b>System Contamination Cleanup</b>	190
General	190
Determining Severity of Contamination	190
Mild System Contamination Cleanup Procedure	192
Severe System Contamination Cleanup Procedure	193
Replacing Pressure Controls without Removing Refrigerant Charge	194
<b>Q270 Condenser Fan Motor Replacement</b>	196
<b>Brazing Procedures for Danfoss Solenoid Valves</b>	197

## COMPONENT SPECIFICATIONS

<b>Main Fuse</b>	199
<b>Bin Switch</b>	199
QM45/Q130/Q170/Q210/Q270	199
<b>Bin Thermostat</b>	199
QM20/QM30/SM50	199
<b>ON/OFF/WASH Toggle Switch</b>	199
<b>Fan Control Cycle</b>	199
QM45/Q130/Q170/Q210/Q270	199
<b>High Pressure Cutout (HPCO) Control</b>	200
<b>Filter-Driers</b>	200
<b>Liquid Line Thermistor</b>	200
QM20/QM30/SM50	200
<b>Total System Refrigerant Charge</b>	201

## CHARTS

<b>Cycle Times, 24 Hr. Ice Production and Refrigerant Pressure Charts</b> . . . . .	203
QM20 Self-contained Air-cooled . . . . .	204
QM30 Self-contained Air-cooled . . . . .	205
QM45 Self-contained Air-cooled . . . . .	206
QM45 Operating Temperatures . . . . .	207
SM50 Self-contained Air-cooled . . . . .	208
Q130 Self-contained Air-cooled (Before Serial Number 310047287) . . . . .	209
Q130 Self-contained Air-cooled (After Serial Number 310047287) . . . . .	210
Q130 Self-contained Water-cooled . . . . .	211
Q170 Self-contained Air-cooled . . . . .	212
Q210 Self-contained Air-cooled . . . . .	213
Q210 Self-contained Water-cooled . . . . .	214
Q270 Self-contained Air-cooled . . . . .	215
Q270 Self-contained Water-cooled . . . . .	216

## DIAGRAMS

<b>Wiring Diagrams</b> . . . . .	217
QM20 . . . . .	218
QM30 . . . . .	219
QM30 . . . . .	220
QM45 . . . . .	221
SM50 . . . . .	222
Q130/Q210 . . . . .	223
Q130/Q170/Q210 . . . . .	224
Q270 . . . . .	225
Q270 . . . . .	226
<b>Electronic Control Boards</b> . . . . .	227
<b>Tubing Schematics</b> . . . . .	230

# General Information

## Model Numbers

This manual covers the following models:

<b>Self-contained Air-cooled</b>	<b>Self-contained Water-cooled</b>
QM20A*	N/A
QM30A*	N/A
QM45A*	N/A
SM50A	N/A
QR0130A	QR0131W
QD0132A	QD0133W
QY0134A	QY0135W
QD0172A	N/A
QY0174A	N/A
QR0210A	QR0211W
QD0212A	QD0213W
QY0214A	QY0215W
QR0270A	QR0271W
QD0272A	QD0273W
QY0274A	QY0275W

\*QM Models – the suffix E represents 230 volt/1 ph/50 hz machine.



### **Warning**

An ice machine contains high voltage electricity and refrigerant charge. Repairs are to be performed by properly trained refrigeration technicians aware of the dangers of dealing with high voltage electricity and refrigerant under pressure.

## How to Read a Model Number

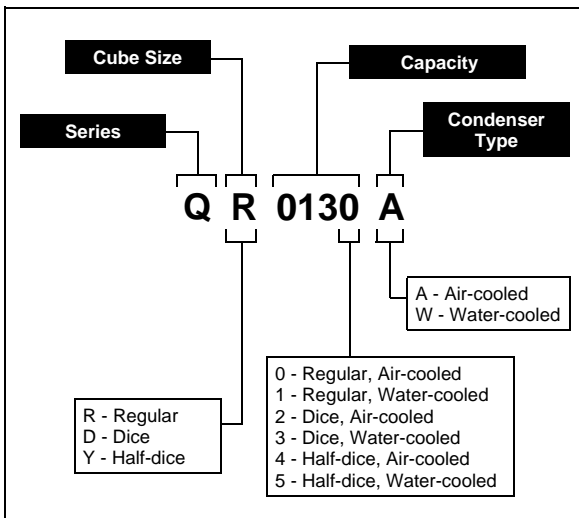

## Accessories

Contact your Manitowoc distributor for these optional accessories:

### BIN CASTER

Replaces standard legs.

### MANITOWOC CLEANER AND SANITIZER

Manitowoc Ice Machine Cleaner and Sanitizer are available in convenient 16 oz. (473 ml) and 1 gal (3.78 l) bottles. These are the only cleaner and sanitizer approved for use with Manitowoc products.

Cleaner Part Number	Sanitizer Part Number
16 oz 94-0456-3	16 oz 94-0565-3
*16 oz 000000084	
1 Gallon 4-0580-3	1 Gallon 94-0581-3

\* This cleaner must be used with all SM50 ice machines. Evaporator damage will result with repeated use or high concentrations of P/N 94-0565-3 cleaner with SM50 ice machines.

 **Caution**

Use only Manitowoc approved Ice Machine Cleaner (part number 94-0546-3 original green ice machine cleaner or 000000084 clear metal safe ice machine cleaner) and Sanitizer (part number 94-0565-3). It is a violation of Federal law to use these solutions in a manner inconsistent with their labeling. Read and understand all labels printed on bottles before use.

NOTE: The Manitowoc Automatic Cleaning System (AuCS®) accessory cannot be used with Undercounter ice machines SM50, QM20, QM30, QM45, Q130, Q170, Q210, or Q270.

QM20, QM30, QM45 ice machines do not have a water curtain covering the evaporator. Q130, Q210, Q170, Q270 have an ice damper that performs the functions of the water curtain see **Ice Damper Removal/Installation** for Details.

## Model/Serial Number Location

The model and serial numbers are required when requesting information from your local Manitowoc distributor, service representative, or Manitowoc Ice. The model and serial number are listed on the OWNER WARRANTY REGISTRATION CARD. They are also listed on the MODEL/SERIAL NUMBER DECAL affixed to the ice machine.

### Q130/Q170/Q210/Q270

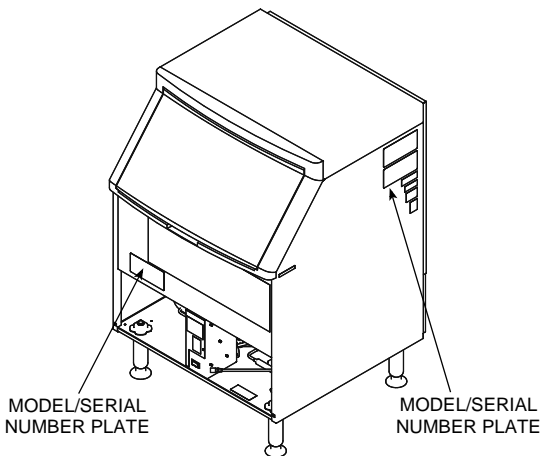

SV1687G

## Model/Serial Number Location

## QM20/QM30

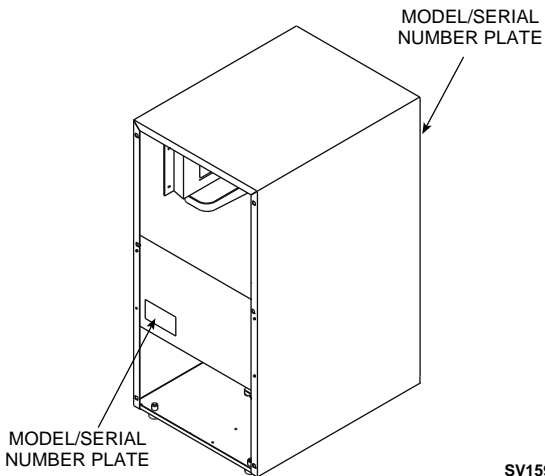

SV1599

## QM45

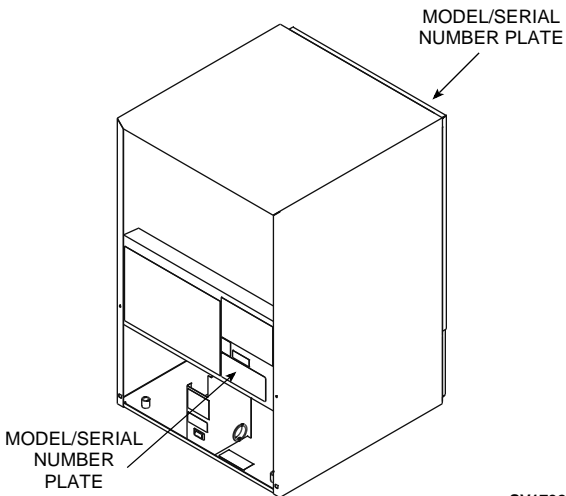

SV1732

# SM50

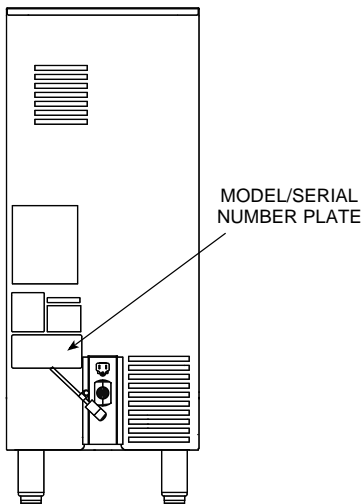



# Ice Machine Warranty Information

## OWNER WARRANTY REGISTRATION CARD

### General

Warranty coverage begins the day the ice machine is installed.

### Important

Complete and mail the OWNER WARRANTY-REGISTRATION CARD as soon as possible to validate the installation date.

If the OWNER WARRANTY REGISTRATION CARD is not returned, Manitowoc will use the date of sale to the Manitowoc Distributor as the first day of warranty coverage for your new ice machine.

## COMMERCIAL WARRANTY COVERAGE

### General

The following Warranty outline is provided for your convenience. For a detailed explanation, read the warranty bond shipped with each product.

Contact your local Manitowoc representative or Manitowoc Ice, if you need further warranty information.

### Parts

#### Q130/Q170/Q210/Q270

1. Manitowoc warrants the ice machine against defects in materials and workmanship, under normal use and service for three (3) years from the date of original installation.
2. The evaporator and compressor are covered by an additional two (2) year (five years total) warranty beginning on the date of the original installation.

#### SM50/QM20/QM30/QM45

1. Manitowoc warrants the ice machine against defects in materials and workmanship, under normal use and service for three (3) years from the date of original installation.

## **Labor**

### Q130/Q170/Q210/Q270

1. Labor required to repair or replace defective components is covered for three (3) years from the date of original installation.
2. The evaporator is covered by an additional two-(2) year (five years total) labor warranty beginning on the date of the original installation (Q130/Q170/Q210/Q270 only).

### SM50/QM20/QM30/QM45

1. Labor required to repair or replace defective components is covered for three (3) years from the date of original installation.

## **Exclusions**

The following items are not included in the ice machine's warranty coverage:

1. Normal maintenance, adjustments and cleaning as outlined in this manual.
2. Repairs due to unauthorized modifications to the ice machine or use of non-standard parts without prior written approval from Manitowoc Ice.
3. Damage caused by improper installation of the ice machine, electrical supply, water supply or drainage, or damage caused by floods, storms, or other acts of God.
4. Premium labor rates due to holidays, overtime, etc.; travel time; flat rate service call charges; mileage and miscellaneous tools and material charges not listed on the payment schedule. Additional labor charges resulting from the inaccessibility of equipment are also excluded.
5. Parts or assemblies subjected to misuse, abuse, neglect or accidents.
6. Damage or problems caused by installation, cleaning and/or maintenance procedures inconsistent with the technical instructions provided in this manual.
7. This warranty is intended exclusively for commercial application. No warranty is extended for personal, family, or household purposes.

## **Authorized Warranty Service**

To comply with the provisions of the warranty, a refrigeration service company qualified and authorized by your Manitowoc distributor, or a Contracted Service Representative must perform the warranty repair.

## **Service Calls**

Normal maintenance, adjustments and cleaning as outlined in this manual are not covered by the warranty.

## **RESIDENTIAL WARRANTY COVERAGE**

### **What Does this Limited Warranty Cover?**

Subject to the exclusions and limitations below, Manitowoc Ice (“Manitowoc”) warrants to the original consumer that any new ice machine manufactured by Manitowoc (the “Product”) shall be free of defects in material or workmanship for the warranty period outlined below under normal use and maintenance, and upon proper installation and start-up in accordance with the instruction manual supplied with the Product.

### **How Long Does this Limited Warranty Last?**

<b>Product Covered</b>	<b>Warranty Period</b>
Ice Machine	Twelve (12) months from the sale date

### **Who is Covered by this Limited Warranty?**

This limited warranty only applies to the original consumer of the Product and is not transferable.

### **What are MANITOWOC ICE’S Obligations Under this Limited Warranty?**

If a defect arises and Manitowoc receives a valid warranty claim prior to the expiration of the warranty period, Manitowoc shall, at its option: (1) repair the Product at Manitowoc’s cost, including standard straight time labor charges, (2) replace the Product with one that is new or at least as functionally equivalent as the original, or (3) refund the purchase price for the Product. Replacement parts are warranted for 90 days or the balance of the original warranty period, whichever is longer. The foregoing constitutes Manitowoc’s sole obligation and the consumer’s exclusive remedy for any breach of this limited warranty. Manitowoc’s liability under this limited warranty is limited to the purchase price of Product. Additional expenses including, without limitation, service travel time, overtime or premium labor charges, accessing or removing the Product, or shipping are the responsibility of the consumer.

## **What Is Not Covered?**

This limited warranty does cover, and you are solely responsible for the costs of: (1) periodic or routine maintenance, (2) repair or replacement of the Product or parts due to normal wear and tear, (3) defects or damage to the Product or parts resulting from misuse, abuse, neglect, or accidents, (4) defects or damage to the Product or parts resulting from improper or unauthorized alterations, modifications, or changes; and (5) defects or damage to any Product that has not been installed and/or maintained in accordance with the instruction manual or technical instructions provided by Manitowoc. To the extent that warranty exclusions are not permitted under some state laws, these exclusions may not apply to you.

EXCEPT AS STATED IN THE FOLLOWING SENTENCE, THIS LIMITED WARRANTY IS THE SOLE AND EXCLUSIVE WARRANTY OF MANITOWOC WITH REGARD TO THE PRODUCT. ALL IMPLIED WARRANTIES ARE STRICTLY LIMITED TO THE DURATION OF THE LIMITED WARRANTY APPLICABLE TO THE PRODUCTS AS STATED ABOVE, INCLUDING BUT NOT LIMITED TO, ANY WARRANTY OF MERCHANTABILITY OR OF FITNESS FOR A PARTICULAR PURPOSE. Some states do not allow limitations on how long an implied warranty lasts, so the above limitation may not apply to you.

IN NO EVENT SHALL MANITOWOC OR ANY OF ITS AFFILIATES BE LIABLE TO THE CONSUMER OR ANY OTHER PERSON FOR ANY INCIDENTAL, CONSEQUENTIAL OR SPECIAL DAMAGES OF ANY KIND (INCLUDING, WITHOUT LIMITATION, LOSS OF PROFITS, REVENUE OR BUSINESS) ARISING FROM OR IN ANY MANNER CONNECTED WITH THE PRODUCT, ANY BREACH OF THIS LIMITED WARRANTY, OR ANY OTHER CAUSE WHATSOEVER, WHETHER BASED ON CONTRACT, TORT OR ANY OTHER THEORY OF LIABILITY. Some states do not allow the exclusion or limitation of incidental or consequential damages, so the above limitation or exclusion may not apply to you.

## **How State Law Applies**

This limited warranty gives you specific legal rights, and you may also have rights that vary from state to state or from one jurisdiction to another.

## **Registration Card**

To secure prompt and continuing warranty service, this warranty registration card must be completed and sent to Manitowoc within thirty (30) days from the sale date. Complete the following registration card and send it to Manitowoc at the address shown above. Retain a copy for your records.

## **HOW TO OBTAIN WARRANTY SERVICE**

To obtain warranty service or information regarding your Product, please contact us at:

MANITOWOC ICE  
2110 S. 26<sup>th</sup> St.,  
P.O. Box 1720  
Manitowoc, WI 54221-1720  
Telephone: 920-682-0161 Fax: 920-683-7585  
[www.manitowocice.com](http://www.manitowocice.com)

# Installation

---

## Location of Ice Machine

The location selected for the ice machine must meet the following criteria. If any of these criteria are not met, select another location.

- The location must be indoors.
- The location must be free of airborne and other contaminants.
- Air temperature:
  - Q130/Q170/Q210/Q270/QM45 must be at least 40°F (4°C) but must not exceed 110°F (43.4°C).
  - QM20/QM30 must be at least 50°F (10°C) but must not exceed 113°F (45°C).
  - SM50 must be at least 50°F (10°C) but must not exceed 110°F (43°C).
- The location must not be near heat-generating equipment or in direct sunlight.
- The location must be capable of supporting the weight of the ice machine and a full bin of ice.
- The location must allow enough clearance for water, drain, and electrical connections in the **rear of the ice machine**.
- The location must not obstruct airflow through or around the ice machine (condenser airflow is in and out the front). Refer to the chart below for clearance requirements.
- The ice machine must be protected if it will be subjected to temperatures below 32°F (0°C). Failure caused by exposure to freezing temperatures is not covered by the warranty.

## Ice Machine Clearance Requirements

	<b>Self-contained Air-cooled</b>	<b>Self-contained Water-cooled</b>
Top/Sides	5" (127 mm)*	5" (127 mm)*
Back	5" (127 mm)*	5" (127 mm)*

\*NOTE: The ice machine may be built into a cabinet.

There is no minimum clearance requirement for the top or left and right sides of the ice machine. The listed values are recommended for efficient operation and servicing only.

## Ice Machine Heat of Rejection

<b>Series Ice Machine</b>	<b>Heat of Rejection*</b>	
	<b>Air Conditioning**</b>	<b>Peak</b>
SM50	1145	2300
QM20	1450	2100
QM30	1600	2350
QM45	1750	2600
Q130	2100	3300
Q170	2200	2600
Q210	2400	3400
Q270	3800	6000

\* B.T.U./Hour

\*\* Because the heat of rejection varies during the ice making cycle, the figure shown is an average.

Ice machines, like other refrigeration equipment, reject heat through the condenser. It is helpful to know the amount of heat rejected by the ice machine when sizing air conditioning equipment where self-contained air-cooled ice machines are installed.



## Leveling the Ice Machine

### QM45/Q130/Q170/Q210/Q270

1. Screw the leveling legs onto the bottom of the ice machine.
2. Screw the foot of each leg in as far as possible.

#### **Caution**

The legs must be screwed in tightly to prevent them from bending.

3. Move the ice machine into its final position.
4. Level the ice machine to ensure that the siphon system functions correctly. Use a level on top of the ice machine. Turn each foot as necessary to level the ice machine from front to back and side to side.

**NOTE:** An optional 2-1/2" (6.35 cm) caster assembly is available for use in place of the legs on the Q130, Q170, Q210, Q270, or QM45. Installation instructions are supplied with the casters.

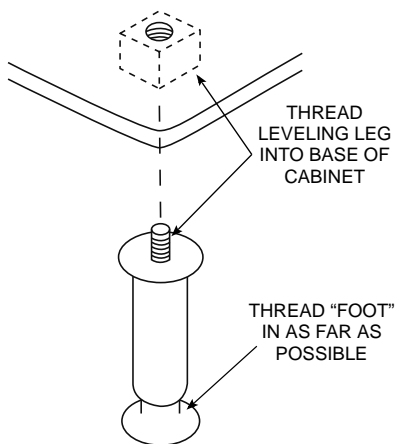

SV1606

### Leg Installation

## SM50/QM20/QM30

After moving the ice machine into the installation location, it must be leveled for proper operation. Follow these steps to level the ice machine:

1. Use a level to check the levelness of the ice machine from front to back and from side to side.
2. If the ice machine is not level, adjust the leveling glides or legs on each corner of the base of the ice machine as necessary.
3. Check the levelness of the ice machine after each adjustment.
4. Repeat steps 2 and 3 until the ice machine is level from front to back and from side to side.

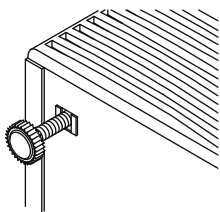

SV1705

### Levelers

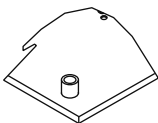

SV1679B

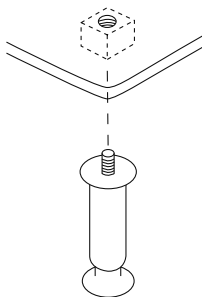

SV1606

### Legs

## **Electrical Requirements**

### **VOLTAGE**

The maximum allowable voltage variation is  $\pm 10\%$  of the rated voltage on the ice machine model/serial number plate at start-up (when the electrical load is highest).

The 115/1/60 ice machines are factory pre-wired with a 6' (1.8 m) power cord, and NEMA 5-15P-plug configuration.

The 208-230/1/60 and 230/1/50 ice machines are factory pre-wired with a power cord only, no plug is supplied.

### **FUSE/CIRCUIT BREAKER**

A separate fuse/circuit breaker must be provided for each ice machine. Circuit breakers must be H.A.C.R. rated (does not apply in Canada).

### **TOTAL CIRCUIT AMPACITY**

The total circuit ampacity is used to help select the wire size of the electrical supply.

The wire size (or gauge) is also dependent upon location, materials used, length of run, etc., so it must be determined by a qualified electrician.

# Electrical Specifications

## Q130/Q170/Q210/Q270 Air-cooled Ice Machine

Ice Machine	Voltage Phase Cycle	Max. Fuse/ Circuit Breaker	Total Amps
<b>Q130 (Before Serial Number 310047287)</b>	115/1/60	15 amp	7.6
	208-230/1/60	15 amp	3.3
	230/1/50	15 amp	3.3
<b>Q130 (After Serial Number 310047287)</b>	115/1/60	15 amp	7.0
	208/1/60	15 amp	3.1
	230/1/50	15 amp	3.0
<b>Q170</b>	115/1/60	15 amp	7.0
<b>Q210</b>	115/1/60	15 amp	6.5
	208-230/1/60	15 amp	3.6
	230/1/50	15 amp	3.6
<b>Q270 Danfoss</b>	115/1/60	15 amp	10.7
	208-230/1/60	15 amp	5.2
	230/1/50	15 amp	5.2
<b>Q270 Tecumseh</b>	115/1/60	15 amp	8.5
	208-230/1/60	15 amp	4.5
	230/1/50	15 amp	4.5

## Q130/Q210/Q270 Water-cooled Ice Machine

Ice Machine	Voltage Phase Cycle	Max. Fuse/ Circuit Breaker	Total Amps
<b>Q130 (Before Serial Number 310047287)</b>	115/1/60	15 amp	6.8
	208-230/1/60	15 amp	2.8
	230/1/50	15 amp	2.8
<b>Q130 (After Serial Number 310047287)</b>	115/1/60	15 amp	6.3
	208/1/60	15 amp	2.6
	230/1/50	15 amp	2.5
<b>Q210</b>	115/1/60	15 amp	6.1
	208-230/1/60	15 amp	3.1
	230/1/50	15 amp	3.1
<b>Q270 Danfoss</b>	115/1/60	15 amp	9.9
	208-230/1/60	15 amp	4.7
	230/1/50	15 amp	4.7
<b>Q270 Tecumseh</b>	115/1/60	15 amp	7.7
	208-230/1/60	15 amp	4.0
	230/1/50	15 amp	4.0



### Warning

All wiring must conform to local, state and national codes.



### Warning

The ice machine must be grounded in accordance with national and local electrical code.

## QM20/QM30/QM45 Air-cooled Ice Machine

<b>Ice Machine</b>	<b>Voltage Phase Cycle</b>	<b>Max. Fuse/ Circuit Breaker</b>	<b>Total Amps</b>
<b>QM20</b>	115/1/60	15 amp	3.5
	230/1/50	15 amp	1.5
<b>QM30</b>	115/1/60	15 amp	5.3
	230/1/50	15 amp	2.6
<b>QM45</b>	115/1/60	15 amp	5.2
	230/1/50	15 amp	2.6

## SM50 Air-cooled Ice Machine

<b>Ice Machine</b>	<b>Voltage Phase Cycle</b>	<b>Max. Fuse/ Circuit Breaker</b>	<b>Total Amps</b>
<b>SM50</b>	115/1/60	15 amp	4.1

## Water Service/Drains

### WATER SUPPLY

Local water conditions may require treatment of the water to inhibit scale formation, filter sediment, and remove chlorine odor and taste.

#### **Important**

If you are installing a Manitowoc water filter system, refer to the Installation Instructions supplied with the filter system for ice making water inlet connections.

### WATER INLET LINES

Follow these guidelines to install water inlet lines:

- Do not connect the ice machine to a hot water supply. Be sure all hot water restrictors installed for other equipment are working. (Check valves on sink faucets, dishwashers, etc.)
- If water pressure exceeds the maximum recommended pressure, 80 psig (5.5 bar) obtain a water pressure regulator from your Manitowoc distributor.
- Install a water shut-off valve for ice making potable water.
- Insulate water inlet lines to prevent condensation.

### DRAIN CONNECTIONS

Follow these guidelines when installing drain lines to prevent drain water from flowing back into the ice machine and storage bin:

- Drain lines must have a 1.5-inch drop per 5 feet of run (2.5 cm per meter), and must not create traps.
- The floor drain must be large enough to accommodate drainage from all drains.
- Run separate bin and ice machine drain lines. Insulate them to prevent condensation.
- Vent the bin and ice machine drain to the atmosphere.

## COOLING TOWER APPLICATIONS

### Water Cooled Models Only

A water-cooling tower installation does not require modification of the ice machine. The water regulator valve for the condenser continues to control the refrigeration discharge pressure.

It is necessary to know the amount of heat rejected, and the pressure drop through the condenser and water valves (inlet to outlet) when using a cooling tower on an ice machine.

- Water entering the condenser must not exceed 90°F (32.2°C).
- Water flow through the condenser must not exceed 5 gallons (19 liters) per minute.
- Allow for a pressure drop of 7 psig (.48 bar) between the condenser water inlet and the outlet of the ice machine.
- Water exiting the condenser must not exceed 110°F (43.3°C).

 **Caution**

Plumbing must conform to state and local codes



## WATER SUPPLY AND DRAIN LINE SIZING/ CONNECTIONS

QM45/Q130/Q170/Q210/Q270

Location	Water Temperature	Water Pressure	Ice Machine Fitting	Tubing Size Up to Ice Machine Fitting
<b>Ice Making Water Inlet</b>	33°F (0.6°C) min. 90°F (32.2°C) max.	20 psi (1.38 bar) min. 80 psi (5.5 bar) max.	3/8" Female Pipe Thread	3/8" (9.5 mm) min. inside diameter
<b>Condenser Water Inlet</b>	33°F (0.6°C) min. 90°F (32.2°C) max.	20 psi (1.38 bar) min. 150 psi (10.3 bar) max.	3/8" Female Pipe Thread	3/8" (9.5 mm) min. inside diameter
<b>Condenser Water Drain</b>	—	—	3/8" Female Pipe Thread	3/8" (9.5 mm) min. inside diameter
<b>Bin Drain</b>	—	—	1/2" Female Pipe Thread	1/2" (12.7 mm) min. inside diameter

Location	Water Temperature	Water Pressure	Ice Machine Fitting	Tubing Size Up to Ice Machine Fitting
<b>Ice Making Water Inlet</b>	50°F (10°C) min. 86°F (30°C) max.	34.8 psi (2.4 bar) min. 89.9 psi (6.2 bar) max.	3/4" Male Connection	3/8" (.95 cm) min. inside diameter
<b>Bin Drain</b>	—	—	5/8" (1.59 cm) inside diameter flexible hose	5/8" (1.59 cm) min. inside diameter

Location	Water Temperature	Water Pressure	Ice Machine Fitting	Tubing Size Up to Ice Machine Fitting
<b>Ice Making Water Inlet</b>	50°F (10°C) min. 90°F (32.2°C) max.	20 psi (1.38 bar) min. 80 psi (5.5 bar) max.	1/4" (.64 cm) ID Copper Tubing	1/4" (.64 cm) min. inside diameter
<b>Bin Drain</b>	—	—	3/4" (1.9 cm) Hose Barb	3/4" (1.9 cm) min. inside diameter
<b>Drain Pump</b>	—	—	3/8" (.96 cm) Hose	3/8" (.96 cm) min. inside diameter
<b>Note:</b> If air temperature is less than 60°F (15.5°C) water temperature must be equal or greater than 50°F (10°C).				

**This Page Intentionally Left Blank**

# Component Identification

## QM45/Q130/Q170/Q210/Q270

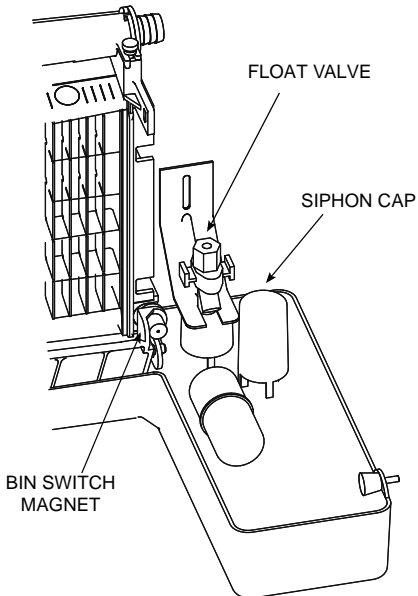
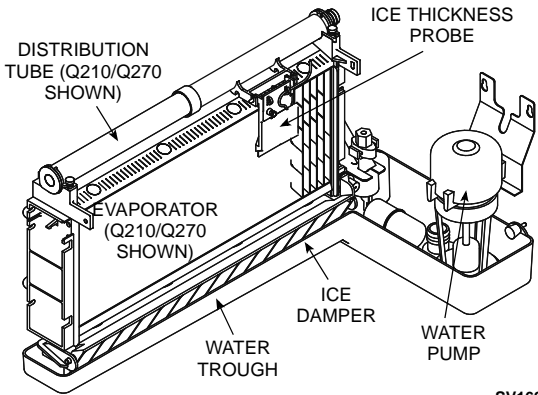

### Evaporator Compartment

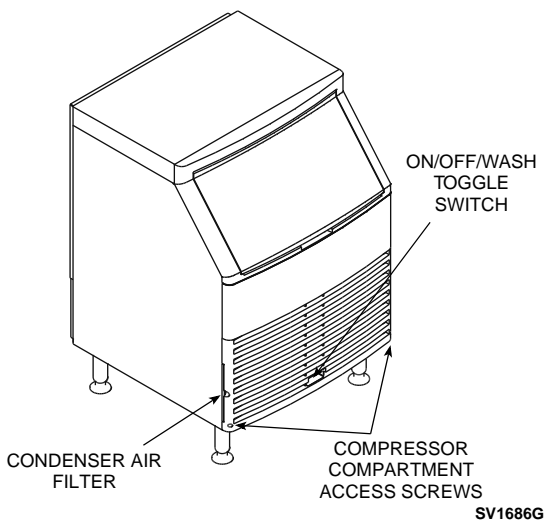

### QM45/Q130/Q170/Q210 Ice Machines

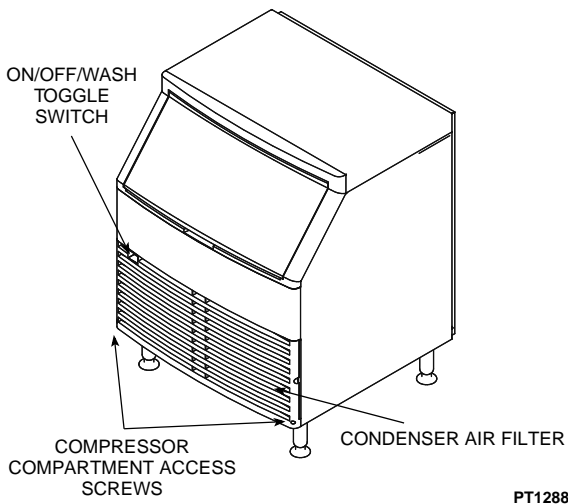

### Q270 Ice Machines

# QM20/QM30

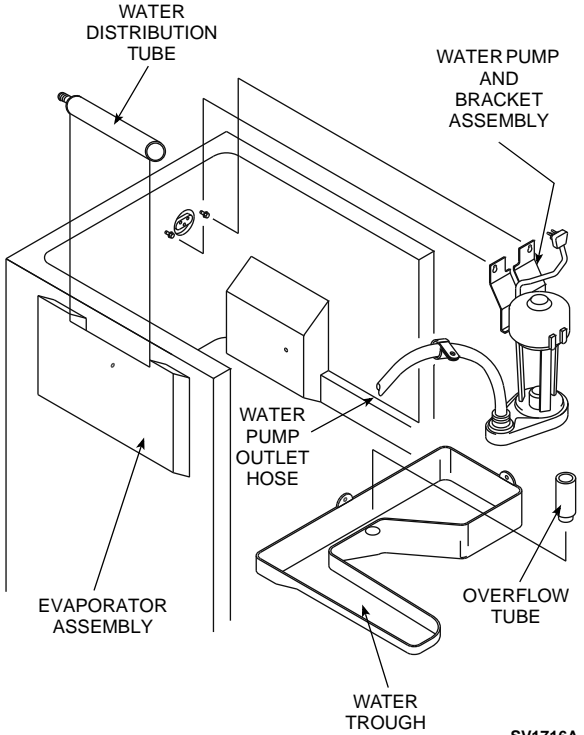

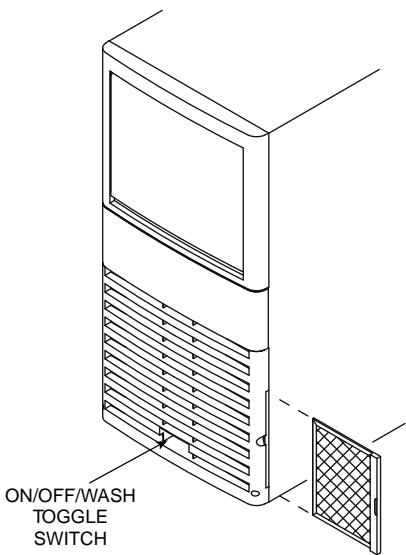

SV1711

### QM20 Ice Machines

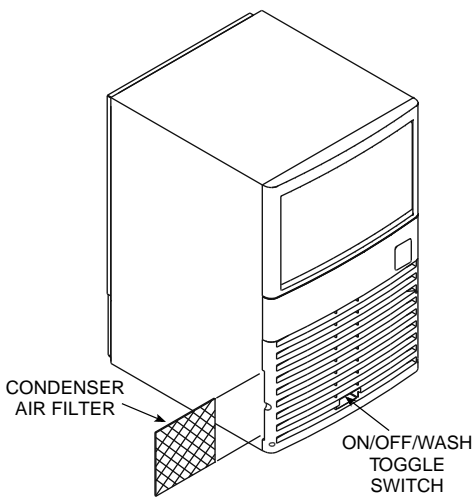

SV1681A

### QM30 Ice Machines



# SM50

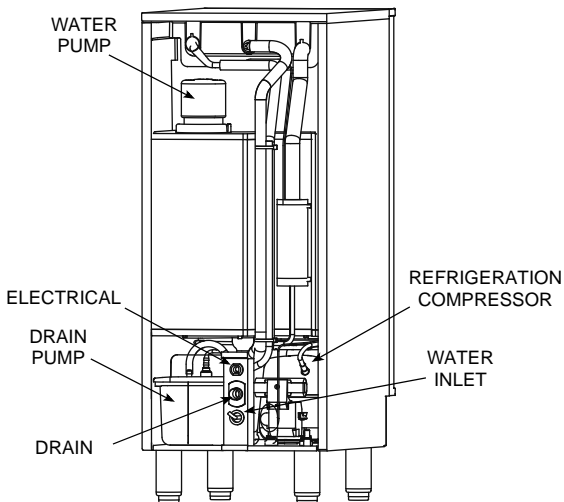
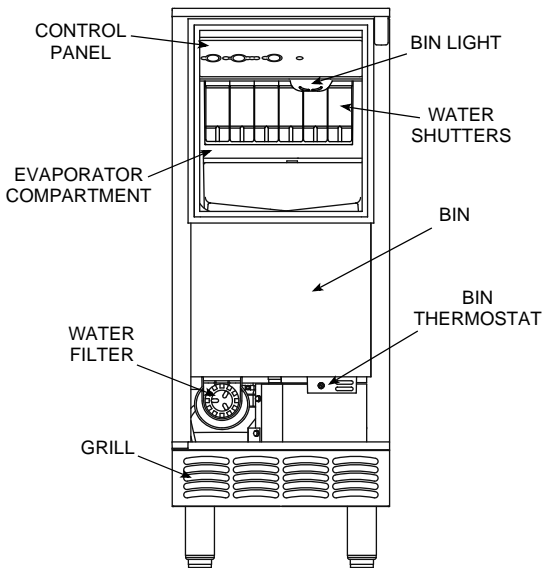

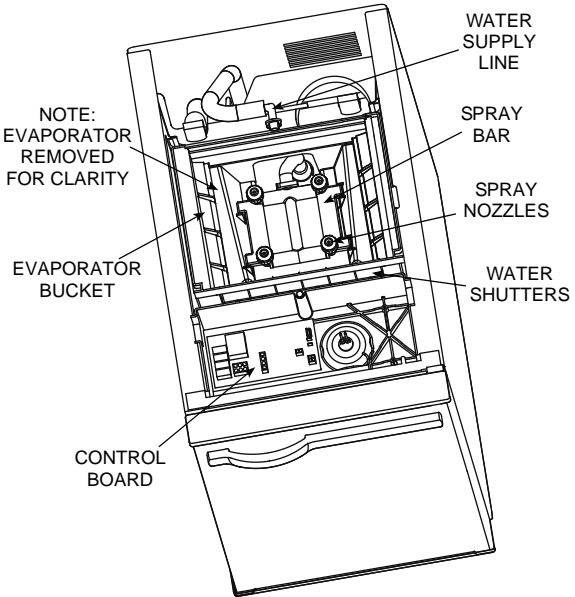
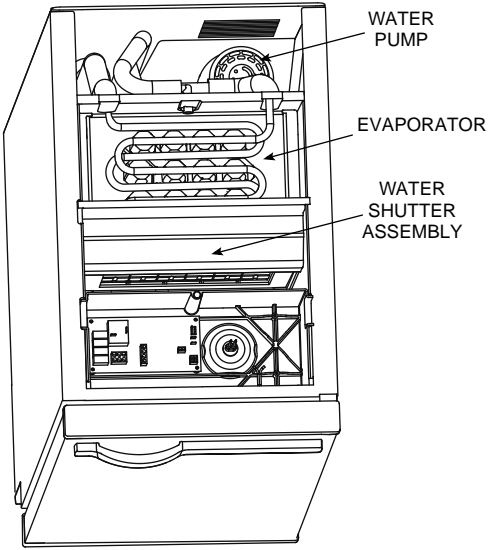

# Maintenance

## Ice Machine Inspection

Check all water fittings and lines for leaks. Also, make sure the refrigeration tubing is not rubbing or vibrating against other tubing, panels, etc.

Do not put anything (boxes, etc.) in front of the ice machine. There must be adequate airflow through and around the ice machine to maximize ice production and ensure long component life.

## Exterior Cleaning

Clean the area around the ice machine as often as necessary to maintain cleanliness and efficient operation.

Sponge any dust and dirt off the outside of the ice machine with mild soap and water. Wipe dry with a clean, soft cloth.

A commercial grade stainless steel cleaner/polish can be used as necessary.

## Cleaning the Condenser



### Warning

Disconnect electric power to the ice machine at the electric service switch before cleaning the condenser.



### Caution

If you are cleaning the condenser fan blades with water, cover the fan motor to prevent water damage.

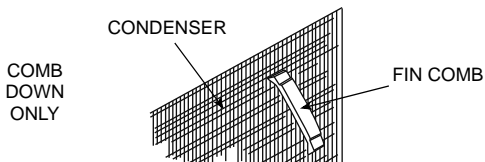

## AIR-COOLED CONDENSER

A dirty condenser restricts airflow, resulting in excessively high operating temperatures. This reduces ice production and shortens component life. Clean the condenser at least every six months. Follow the steps below.



### Warning

The condenser fins are sharp. Use care when cleaning them.

1. The washable aluminum filter on self-contained air-cooled ice machines is designed to catch dust, dirt, lint and grease. This helps keep the condenser clean. Clean the filter with a mild soap and water solution.
2. Clean the outside of the condenser with a soft brush or a vacuum with a brush attachment. Clean from top to bottom, not side to side. Be careful not to bend the condenser fins.
3. Shine a flashlight through the condenser to check for dirt between the fins. If dirt remains:
  - A. Blow compressed air through the condenser fins from the inside. Be careful not to bend the fan blades.
  - B. Use a commercial condenser coil cleaner. Follow the directions and cautions supplied with the cleaner.
4. Straighten any bent condenser fins with a fin comb.
5. Carefully wipe off the fan blades and motor with a soft cloth. Do not bend the fan blades. If the fan blades are excessively dirty, wash with warm, soapy water and rinse thoroughly.

## WATER-COOLED CONDENSER AND WATER REGULATING VALVE

The water-cooled condenser and water regulating valve may require cleaning due to scale build-up.

Low ice production, high water consumption and high operating temperatures and pressures all may be symptoms of restrictions in the condenser water circuit.

Because the cleaning procedures require special pumps and cleaning solutions, they must be performed by qualified maintenance or service personnel.

## QM45/Q130/Q170/Q210/Q270

### INTERIOR CLEANING AND SANITIZING

#### General

Clean and sanitize the ice machine every six months for efficient operation. If the ice machine requires more frequent cleaning and sanitizing, consult a qualified service company to test the water quality and recommend appropriate water treatment.

The ice machine must be taken apart for cleaning and sanitizing.

#### **Caution**

Use only Manitowoc approved Ice Machine Cleaner (part number 95-0546-3) and Sanitizer (part number 94-0565-3). It is a violation of Federal law to use these solutions in a manner inconsistent with their labeling. Read and understand all labels printed on bottles before use.

#### Cleaning and Sanitizing Procedure

#### **Caution**

Do not mix Ice Machine Cleaner and Sanitizer solutions together. It is a violation of Federal law to use these solutions in a manner inconsistent with their labeling.

#### **Warning**

Wear rubber gloves and safety goggles (and/or face shield) when handling Ice Machine Cleaner or Sanitizer.

Ice machine cleaner is used to remove lime scale and mineral deposits. Ice machine sanitizer disinfects and removes algae and slime.

**Step 1** Set the toggle switch to the OFF position after ice falls from the evaporator at the end of a Harvest cycle. Or, set the switch to the OFF position and allow the ice to melt off the evaporator.



### **Caution**

Never use anything to force ice from the evaporator. Damage may result.

**Step 2** Remove all ice from the bin.

**Step 3** To start a cleaning cycle, move the toggle switch to the WASH position.

**Step 4** Add the proper amount of Manitowoc Ice Machine Cleaner to the water trough.

<b>Model</b>	<b>Amount of Cleaner</b>
QM45	1.5 ounce (45 ml)
Q130	1 ounce (30 ml)
Q170	2 ounces (60 ml)
Q210	2 ounces (60 ml)
Q270	2 ounces (60 ml)

**Step 5** Wait until the clean cycle is complete (approximately 22 minutes) then place the toggle switch in the OFF position, disconnect power and water supplies to the ice machine.



### **Warning**

Disconnect electric power to the ice machine at the electric switch box before proceeding.

**Step 6** Remove parts for cleaning.

- A. Remove Two Thumbscrews and Water Pump Cover (When Used).**
- B. Remove the Vinyl Hose Connecting the Water Pump and Water Distribution Tube**
- C. Remove Water Pump**
  - Disconnect the water pump power cord
  - Loosen the screws securing the pump-mounting bracket to the bulkhead
  - Lift the pump and bracket assembly off the mounting screws.

WHEN USED- REMOVE  
THUMBSCREWS AND  
WATER PUMP COVER

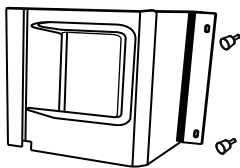

DO NOT SOAK  
WATER PUMP MOTOR IN  
CLEANER OR SANITIZER  
SOLUTIONS

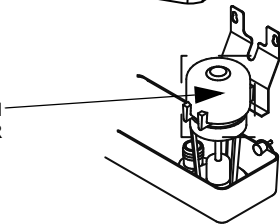

### Water Pump Removal

## D. Remove the Ice Thickness Probe

- Compress the side of the ice thickness probe near the top hinge pin and remove it from the bracket.

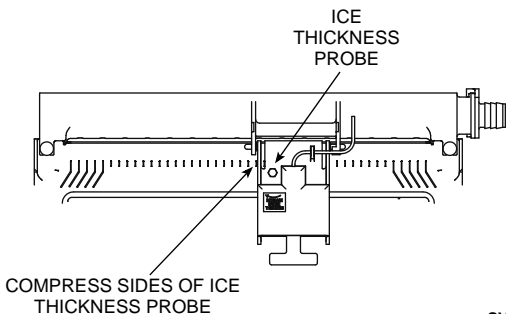

SV1138A

### Ice Thickness Probe Removal

**NOTE:** At this point, the ice thickness probe can easily be cleaned. If complete removal is desired follow the ice thickness probe wire to the bulkhead grommet (exit point) in the back wall. Pop the bulkhead grommet out of the back wall by inserting fingernails or a flat object between the back wall and the grommet and prying forward. Pull the bulkhead grommet and wire forward until the connector is accessible, then disconnect the wire lead from the connector.

### Ice Thickness Probe Cleaning

- Mix a solution of Manitowoc ice machine cleaner and water (2 ounces of cleaner to 16 ounces of water) in a container.
- Soak the ice thickness probe a minimum of 10 minutes.

Clean all ice thickness probe surfaces and verify the ice thickness probe cavity is clean. Rinse thoroughly with clean water, then dry completely. Incomplete rinsing and drying of the ice thickness probe can cause premature harvest.



## E. Remove the Water Distribution Tube

### Q170/Q210/Q270 Models

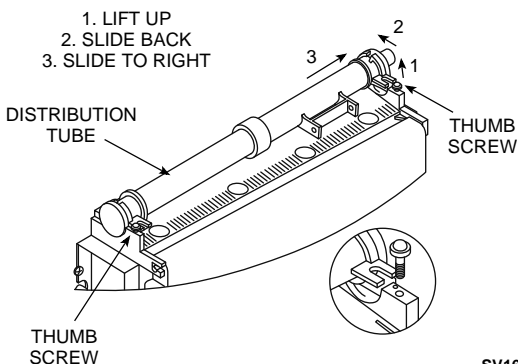

SV1630

### Q170/Q210/Q270 Water Distribution Tube Removal

- Loosen the two thumbscrews, which secure the distribution tube.
- Lift the right side of the distribution tube up off the locating pin, then slide it back and to the right.

#### **Caution**

Do not force this removal. Be sure the locating pin is clear of the hole before sliding the distribution tube out.

## Disassembly

- Twist both of the inner tube ends until the tabs line up with the keyways.
- Pull the inner tube ends outward.

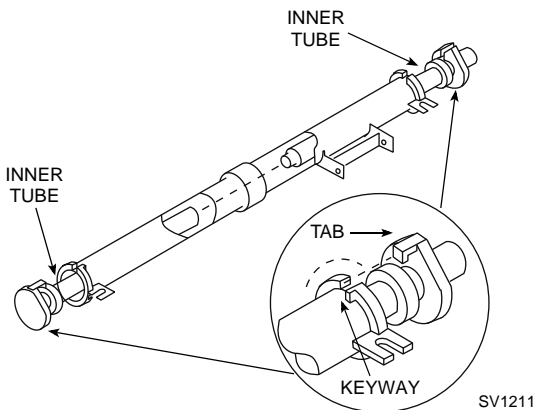

**Q210/Q270 Water Distribution Tube Disassembly**

## Q130 Models

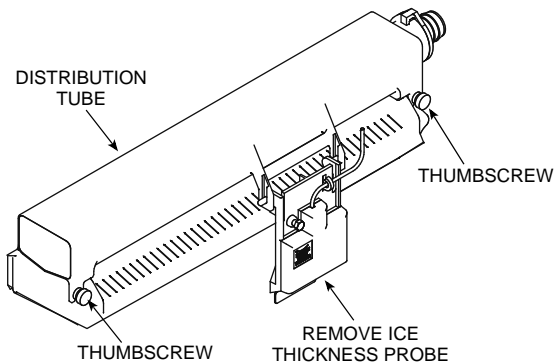

SV1731C

### Q130 Water Distribution Tube Removal

- Loosen the two thumbscrews, which secure the distribution tube.
- Lift the distribution tube up off the thumbscrews.

### Disassembly

- Twist the barbed end until the tab lines up with the keyway.
- Pull the inner tube end outward.

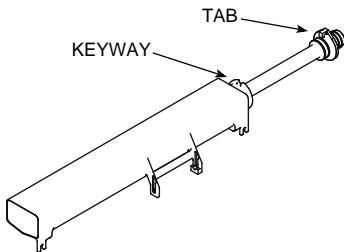

SV1741

### Q130 Water Distribution Tube Disassembly

## F. Remove the Float Valve

- Turn the splash shield counterclockwise one or two turns.

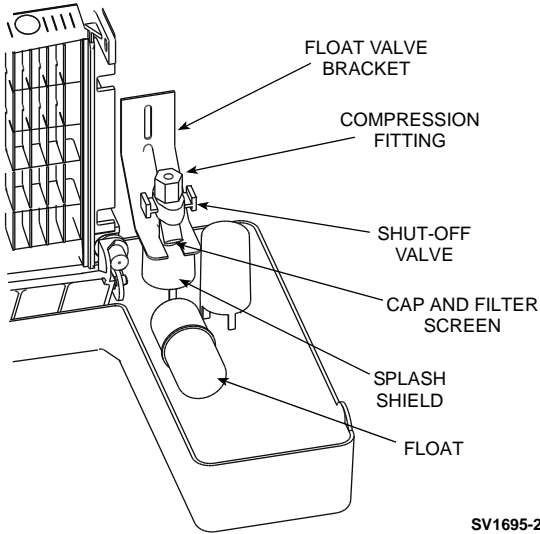

SV1695-2

### FLOAT VALVE REMOVAL

- Pull the float valve forward and off the mounting bracket.
- Disconnect the water inlet tube from the float valve at the compression fitting.
- Remove the cap and filter screen for cleaning.

## G. Remove the Water Trough

- Apply downward pressure on the siphon tube and remove from the bottom of the water trough.
- Remove the upper thumbscrew.
- While supporting the water trough remove the two thumbscrews from beneath the water trough.
- Remove the water trough from the bin area.

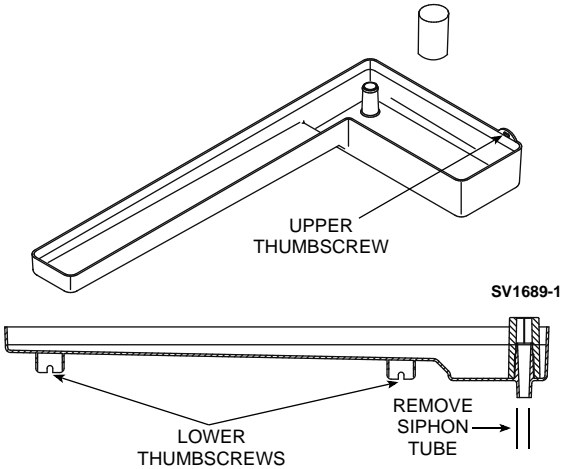

SV1689-2

REMOVE THE ICE DAMPER.

## Q130

- Grasp left side of ice damper and apply pressure against the right-hand ice damper mounting bracket.
- Pull forward on the ice damper until the left-hand mounting pin disengages.

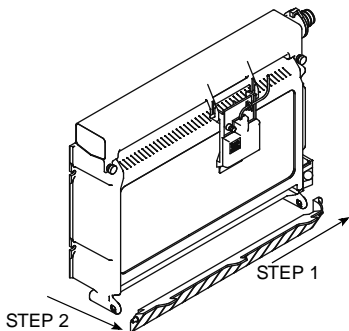

SV1731F

## Installation

- Grasp the right side of ice damper and place left hand pin in the mounting bracket.
- While applying pressure against the left-hand mounting bracket push the damper until the right-hand mounting pin engages.

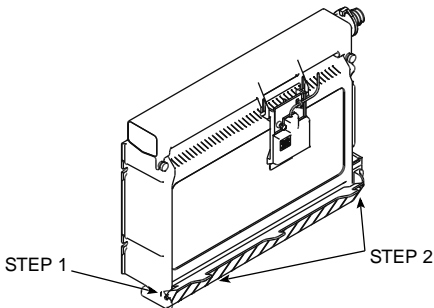

SV1731G

## Q170/Q210/Q270

- Grasp ice damper and apply pressure toward the left hand mounting bracket.
- Apply pressure to the right hand mounting bracket with thumb.
- Pull ice damper forward when the right hand ice damper pin disengages.

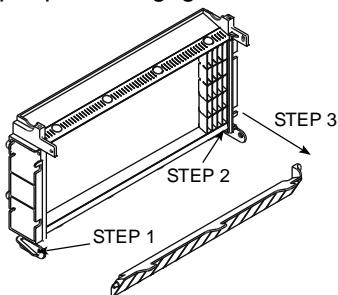

SV1742A

## Installation

- Place ice damper pin in left hand mounting bracket and apply pressure toward the left hand mounting bracket.
- Apply pressure to the right hand mounting bracket with thumb.
- Push ice damper toward evaporator until right hand damper pin engages.

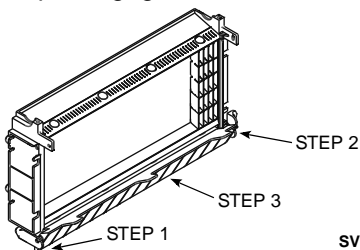

SV1742H

## Remove the Bin Door

- Grasp the rear of the bin door and pull bin door forward approximately 5".
- Slide bin door to the rear while applying upward pressure (The rear door pins will ride up into the track slot and slide backward to the stop tab).
- While applying pressure against the bin door pull down on the rear of each bin door track until the door pins clear the stop tabs.
- Slide the rear door pins off the end and then below the door track. Slide bin door forward allowing the back of the door to lower into the bin. Continue forward with the bin door until the front pins bottom out in the track.
- Lift right side of door until the front pins clear the track, then remove door from bin.
- Remove rollers (4) from all door pins.

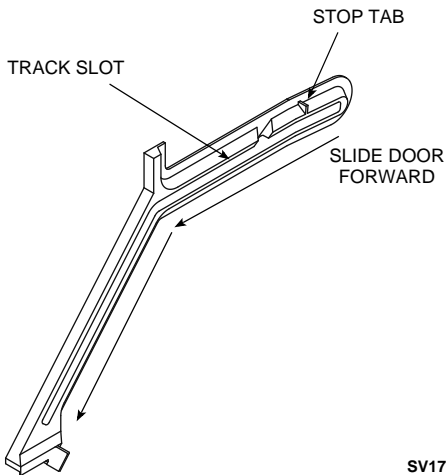

SV1748

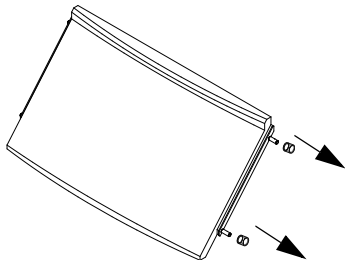



**Step 7** Mix a solution of cleaner and warm water. Depending on the amount of mineral buildup, a larger quantity of solution may be required. Use the ratio in the table below to mix enough solution to thoroughly clean all parts.

Solution Type	Water	Mixed with
Cleaner	1 gal. (4 l)	16 oz (500 ml) cleaner

**Step 8** Use  $\frac{1}{2}$  of the cleaner/water solution to clean all components. The cleaner solution will foam when it contacts lime scale and mineral deposits; once the foaming stops use a soft bristle brush, sponge or cloth (not a wire brush) to carefully clean the parts. Soak the parts for 5 minutes (15 – 20 minutes for heavily scaled parts). Rinse all components with clean water.

**Step 9** While components are soaking, use  $\frac{1}{2}$  of the cleaner/water solution to clean all foodzone surfaces of the ice machine and bin. Use a nylon brush or cloth to thoroughly clean the following ice machine areas:

- Evaporator plastic parts – including top, bottom and sides
- Bin bottom, sides and top

Rinse all areas thoroughly with clean water.

**Step 10** Mix a solution of sanitizer and warm water.

Solution Type	Water	Mixed With
Sanitizer	6 gal. (23 l)	4 oz (120 ml) sanitizer

**Step 11** Use  $\frac{1}{2}$  of the sanitizer/water solution to sanitize all removed components. Use a cloth or sponge to liberally apply the solution to all surfaces of the removed parts or soak the removed parts in the sanitizer/water solution. Do not rinse parts after sanitizing.

**Step 12** Use 1/2 of the sanitizer/water solution to sanitize all foodzone surfaces of the ice machine and bin. Use a cloth or sponge to liberally apply the solution. When sanitizing, pay particular attention to the following areas:

- Evaporator plastic parts - including top, bottom and sides
- Bin bottom, sides and top

Do not rinse the sanitized areas.

**Step 13** Replace all removed components.

**Step 14** Reapply power and water to the ice machine and place the toggle switch in the WASH position.

Add the proper amount of Manitowoc Ice Machine Sanitizer to the water trough.

Model	Amount of Sanitizer
QM45	1.5 ounces (45 ml)
Q130	1.6 ounces (48 ml)
Q170	2.2 ounces (66 ml)
Q210	2.2 ounces (66 ml)
Q270	1.9 ounces (57 ml)

**Step 15** Wait until the sanitize cycle is complete (approximately 22 minutes) then place the toggle switch in the OFF position, disconnect power and water supplies to the ice machine.



### Warning

Disconnect electric power to the ice machine at the electric switch box before proceeding.

**Step 16** Repeat step 6 to remove parts for hand sanitizing.

**Step 17** Mix a solution of sanitizer and warm water.

Solution Type	Water	Mixed With
Sanitizer	6 gal. (23 l)	4 oz (120 ml) sanitizer

**Step 18** Use 1/2 of the sanitizer/water solution to sanitize all removed components. Use a cloth or sponge to liberally apply the solution to all surfaces of the removed parts or soak the removed parts in the sanitizer/water solution. Do not rinse parts after sanitizing.

**Step 19** Use 1/2 of the sanitizer/water solution to sanitize all foodzone surfaces of the ice machine and bin. Use a cloth or sponge to liberally apply the solution. When sanitizing, pay particular attention to the following areas:

- Evaporator plastic parts - including top, bottom and sides
- Bin bottom, sides and top

Do not rinse the sanitized areas.

**Step 20** Replace all removed components.

**Step 21** Reapply power and water to the ice machine and place the toggle switch in the ICE position.

## QM20/QM30

### CLEANING AND SANITIZING PROCEDURE

#### **Caution**

Use only Manitowoc approved Ice Machine Cleaner (part number 94-0546-3) and Sanitizer (part number 94-0565-3). It is a violation of Federal law to use these solutions in a manner inconsistent with their labeling. Read and understand all labels printed on bottles before use.

#### **Caution**

Do not mix Ice Machine Cleaner and Sanitizer solutions together. It is a violation of Federal law to use these solutions in a manner inconsistent with their labeling.

#### **Warning**

Wear rubber gloves and safety goggles (and/or face shield) when handling Ice Machine Cleaner or Sanitizer.

Ice machine cleaner is used to remove lime scale and mineral deposits. Ice machine sanitizer disinfects and removes algae and slime.

**Step 1** Set the toggle switch to the OFF position after ice falls from the evaporator at the end of a Harvest cycle. Or, set the switch to the OFF position and allow the ice to melt off the evaporator.

 **Caution**

Never use anything to force ice from the evaporator. Damage may result.

**Step 2** Remove all ice from the bin.

**Step 3** To start a cleaning cycle, move the toggle switch to the WASH position.

**Step 4** Wait until water flows over the evaporator (about three minutes) then add the proper amount of Manitowoc Ice Machine Cleaner to the water trough.

Model	Amount of Cleaner
QM20/QM30	45 ml

**Step 5** Wait until the clean cycle is complete (approximately 45 minutes) then place the toggle switch in the OFF position, disconnect power and water supplies to the ice machine.

 **Warning**

Disconnect electric power to the ice machine at the electric switch box before proceeding.

**Step 6** Remove parts for cleaning.

**A. Remove the Overflow Tube**

- To remove the tube, lift it up while using a slight back and forth motion to loosen it from the drain hole.

When installing the tube, be sure it is completely inserted into the drain hole to prevent water leakage during normal operation.

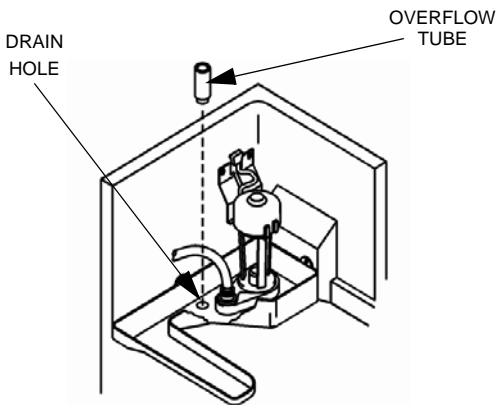

**Removing the Overflow Tube**

**B. Remove the Vinyl Hose**

- Disconnect the water pump discharge hose from the distribution tube and water pump.

### C. Remove the Water Pump

- Disconnect the water pump power cord.
- Loosen the screws that hold the water pump in place.
- Lift the water pump and bracket assembly up and off the screws.

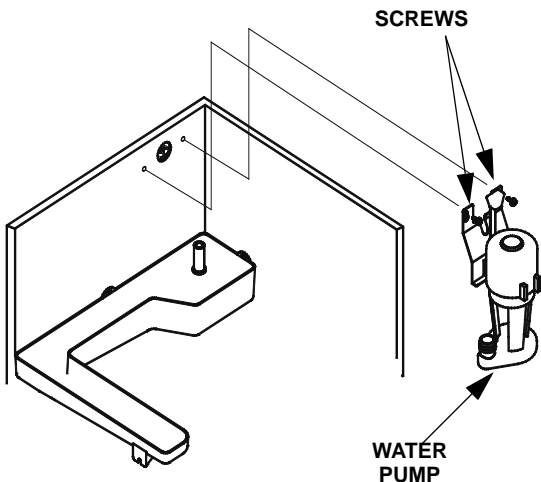

### Removing the Water Pump

### D. Remove the Water Trough

- Remove the screws holding the water trough to the walls of the cabinet.

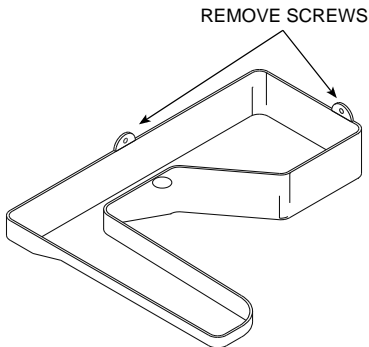

SV3019

**Step 7** Mix a solution of cleaner and warm water. Depending on the amount of mineral buildup, a larger quantity of solution may be required. Use the ratio in the table below to mix enough solution to thoroughly clean all parts.

Solution Type	Water	Mixed with
Cleaner	4L. (1 gal)	500 ml (16 oz) cleaner

**Step 8** Use half of the cleaner/water solution to clean all components. The cleaner solution will foam when it contacts lime scale and mineral deposits; once the foaming stops use a soft bristle brush, sponge or cloth (not a wire brush) to carefully clean the parts. Soak the parts for 5 minutes (15 – 20 minutes for heavily scaled parts). Rinse all components with clean water.

**Step 9** While components are soaking, use half of the cleaner/water solution to clean all foodzone surfaces of the ice machine and bin. Use a nylon brush or cloth to thoroughly clean the following ice machine areas:

- Evaporator plastic parts – including top, bottom and sides
- Bin bottom, sides and top

Rinse all areas thoroughly with clean water.

**Step 10** Mix a solution of sanitizer and warm water.

Solution Type	Water	Mixed With
Sanitizer	23 L. (6 gal )	120 ml (4 ounces) sanitizer

**Step 11** Use half of the sanitizer/water solution to sanitize all removed components. Use a cloth or sponge to liberally apply the solution to all surfaces of the removed parts or soak the removed parts in the sanitizer/water solution. Do not rinse parts after sanitizing.



**Step 12** Use half of the sanitizer/water solution to sanitize all foodzone surfaces of the ice machine and bin. Use a cloth or sponge to liberally apply the solution. When sanitizing, pay particular attention to the following areas:

- Evaporator plastic parts - including top, bottom and sides
- Bin bottom, sides and top

Do not rinse the sanitized areas.

**Step 13** Replace all removed components.

**Step 14** Reapply power and water to the ice machine and place the toggle switch in the WASH position.

**Step 15** Add the proper amount of Manitowoc Ice Machine Sanitizer to the water trough.

Model	Amount of Sanitizer
QM20/QM30	45 ml

**Step 16** Wait until the sanitize cycle is complete (approximately 45 minutes) then place the toggle switch in the OFF position, disconnect power and water supplies to the ice machine.



### Warning

Disconnect electric power to the ice machine at the electric switch box before proceeding.

**Step 17** Repeat step 6 to remove parts for hand sanitizing.

**Step 18** Mix a solution of sanitizer and warm water.

Solution Type	Water	Mixed With
Sanitizer	23L. (6 gal )	120 ml (4 oz) sanitizer

**Step 19** Use half of the sanitizer/water solution to sanitize all removed components. Use a cloth or sponge to liberally apply the solution to all surfaces of the removed parts or soak the removed parts in the sanitizer/water solution. Do not rinse parts after sanitizing.

**Step 20** Use half of the sanitizer/water solution to sanitize all foodzone surfaces of the ice machine and bin. Use a cloth or sponge to liberally apply the solution. When sanitizing, pay particular attention to the following areas:

- Evaporator plastic parts - including top, bottom and sides
- Bin bottom, sides and top

Do not rinse the sanitized areas.

**Step 21** Replace all removed components.

**Step 22** Reapply power and water to the ice machine and place the toggle switch in the ICE position.

## SM50

### CLEANING PROCEDURE

SM50 uses a tin plated evaporator. Do not use standard cleaner, use only 000000084 cleaner for this ice machine.

#### **Caution**

Use only Manitowoc approved Ice Machine Cleaner (part number 000000084 clear metal safe ice machine cleaner) and Sanitizer (part number 94-0565-3). It is a violation of Federal law to use these solutions in a manner inconsistent with their labeling. Read and understand all labels printed on bottles before use.

Ice machine cleaner is used to remove lime scale or other mineral deposits. It is not used to remove algae or slime. Refer to "Sanitizing Procedure" on page 68 for removal of algae and slime.

1. To start a cleaning cycle, press the CLEAN switch. The ice machine will initiate a 2 minute harvest to remove any ice from the evaporator. Or, set the switch to the OFF position and allow the ice to melt off the evaporator.

#### **Caution**

Never use anything to force ice from the evaporator. Damage may result.

2. Remove all ice from the bin.
3. The clean light will energize to indicate the clean cycle has started.
4. Wait until the Clean light flashes (3 minutes) then add 3 oz of Manitowoc cleaner by lifting the water shutter and pouring directly into the spray area. The ice machine will automatically time out a ten minute cleaning cycle, followed by eight rinse cycles, and stop. The Clean light will turn off to indicate the Clean cycle is complete. This entire cycle lasts approximately 30 minutes.

5. When the cleaning process stops, remove all parts as described in Removal of Parts for Cleaning and Sanitizing.
6. Mix 16 oz (480 ml) cleaner with 1 gal (4 L) of warm water in a non metallic container.-
7. Take all components to sink for cleaning. Use 1/2 of the Cleaner/Water mixture and clean all components with a soft nylon brush or cloth. Disassemble spray bar, remove nozzles and inserts and soak for 5 minutes. For heavily scaled parts, soak in solution for 15 – 20 minutes. Rinse all components with clean water.
8. While components are soaking, use nylon brush or cloth to clean inside of ice bin. Clean inside of door, door gasket, bin, top of evaporator and evaporator bucket. Rinse all areas thoroughly with clean water.

## **SANITIZING PROCEDURE**

Use sanitizer to remove algae or slime. Do not use it to remove lime scale or other mineral deposits.

**NOTE:** Always perform a cleaning procedure before sanitizing the ice machine.

1. Mix 4 oz (120 ml) sanitizer with 6 gal (13 L) of warm water in a non metallic container.
2. Take all components to sink for sanitizing. Use the Sanitizer/Water mixture and sanitize all components that were removed for the Cleaning Procedure with a soft nylon brush or cloth. Soak for 5 minutes. Do not rinse sanitized components.
3. While components are soaking, use nylon brush or cloth to sanitize the inside of ice bin. Sanitize inside of door, door gasket, bin, top of evaporator and evaporator bucket. Do not rinse sanitized components.
4. Replace all components removed.
5. To start a sanitizing cycle, press the CLEAN switch. The Clean light will energize to indicate the sanitizing cycle has started.

6. Wait until the Clean light flashes (3 minutes) then add 0.5 oz (15 ml) of Manitowoc sanitizer by lifting the water shutter and pouring directly into the spray area. The ice machine will automatically time out a ten minute cleaning cycle, followed by eight rinse cycles, and stop. The Clean light will turn off to indicate the Cleaning cycle is completed. This entire cycle lasts approximately 30 minutes.

NOTE: The ice machine will automatically continue from the previous point before the clean cycle was initiated.

- If the ice machine was in the ice making cycle, the control board will initiate a 2 minute harvest cycle, perform the clean cycle and start ice making again automatically.
- If the ice machine was in the off cycle, the control board will perform a clean cycle and turn off automatically.
- If the ice machine was in a delay mode, the control board will perform a clean cycle and resume the delay period automatically.

## REMOVAL OF PARTS FOR CLEANING AND SANITIZING

1. Disconnect power to the ice machine at the electric switch box.
2. Turn off the water supply to the ice machine at the water service valve.



### Warning

Disconnect electric power to the ice machine at the electric switch box before proceeding.

3. Remove the parts or components you want to clean or sanitize:

### WATER SHUTTERS

The water shutter is designed to keep the spraying water from escaping the evaporator compartment.

To remove just the water shutters:

1. Grasp one end of the water shutter and lift up.
2. Pivot water shutter and disengage remaining end.

3. To re-install into ice machine, grasp one end of the water shutters, install one end, pivot the opposite end and pull down into position. Make sure tabs are secure in grooves.

To remove water shutter assembly:

1. Slide evaporator bucket forward 1/2" (13 mm).
2. Lift shutter assembly straight up.

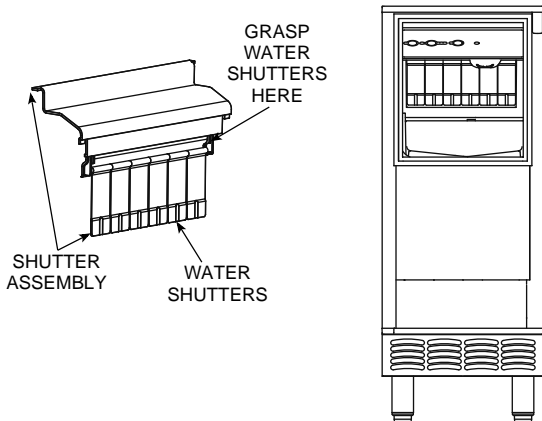

**Warning**

Removing the water shutters while the water pump is running will allow water to spray from ice machine. Disconnect the electrical power to the ice machine at the electric service switch box and turn off the water supply.

## ICE CHUTE

The ice chute is positioned over the spray nozzles and allows the ice to easily fall into the bin. It must be firmly positioned over the spray bar, with the front edge inside the water trough. Spray nozzles must align with the spray holes or spray water will fall into the bin.

1. Grab protruding spray hole on one end and lift up and remove.
2. To re-install ice chute, grasp protruding spray hole and position over Water Distribution Assembly. Make sure rear supports are over spray bar, and front edge is inside of water trough.

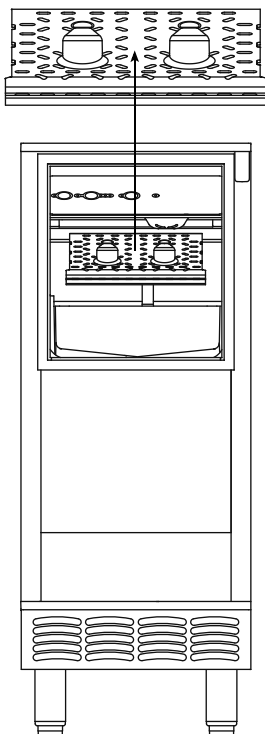

## SUMP DRAIN OVERFLOW TUBE

1. Remove clamp.
2. Pull down to remove overflow tube and tubing as an assembly. The sump trough water will drain into the bin.
3. Remove overflow tube from vinyl tubing by pulling.

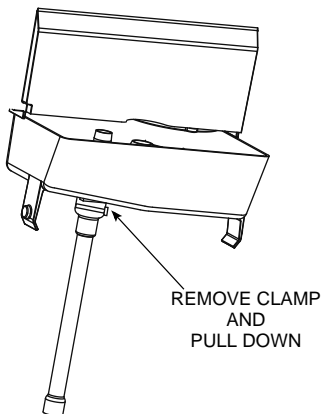



## WATER TROUGH

1. Depress tabs on right and left side of the water trough.
2. Allow front of water trough to drop as you pull forward to disengage the rear pins.

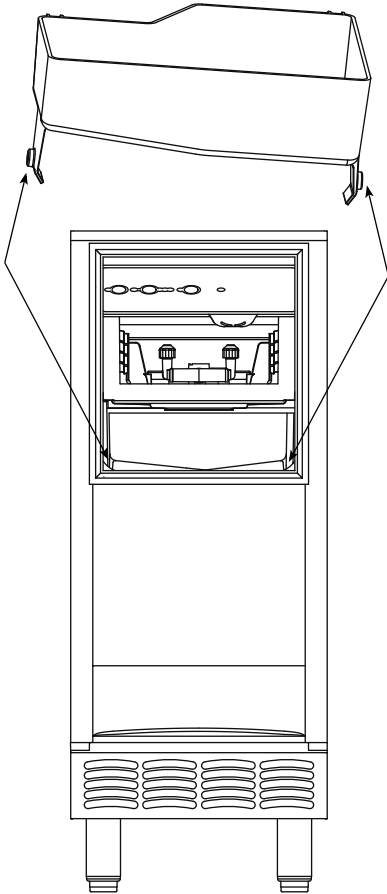

## SPRAY BAR, WATER PUMP AND HOSE

### **Warning**

Disconnect the electric power to the ice machine at the electric service switch box and turn off the water supply before proceeding.

Remove spray bar clamp and spray bar.

1. Grasp pump and pull straight down until water pump disengages and electrical connector is visible.
2. Disconnect the electrical connector.
3. Remove the water pump from ice machine.
4. Remove clamp from hose to remove from pump.
5. Do not submerge the water pump motor in cleaner or sanitizer. If soaking is required, immerse pump to normal water level during the freeze.

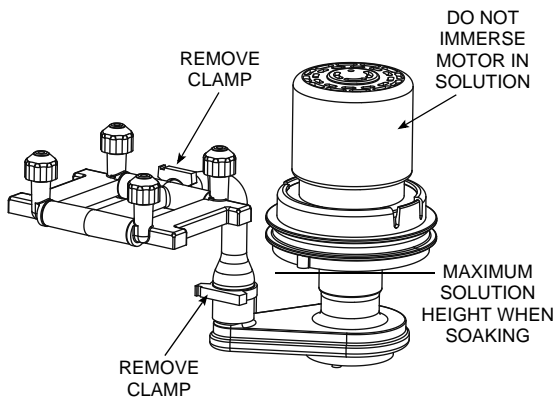

## SPRAY BAR DISASSEMBLY

The spray bar supplies water to the individual ice making cups. Water from the water pump sprays through the nozzles, located on the upper portion of the tubes.

1. Grasp one end of the spray bar, lift up and remove from seat formed in evaporator bucket.
2. Remove clamp on water inlet tubing by grasping both ears on clip and separating.
3. Apply food grade lubricant to ease re-assembly of spray bar components when necessary.
4. To re-install spray bar, position water inlet tubing on inlet ports, and squeeze clips until tight.
5. Reposition assembly on water trough seat. Nozzles and inserts can be removed for cleaning by unscrewing nozzles. Inserts are located inside the spray bar ports. The spray bar also disassembles for easy cleaning.

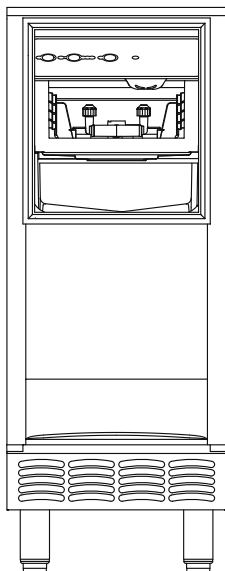
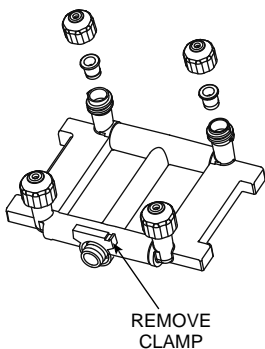

 **Warning**

Wear rubber gloves and safety goggles (and/or face shield) when handling Ice Machine Cleaner or Sanitizer.

6. Soak the removed part(s) in a properly mixed solution.

<b>Solution Type</b>	<b>Water</b>	<b>Mixed With</b>
Cleaner	1 gal (4 l)	16 oz (500 ml) cleaner
Sanitizer	6 gal (23 l)	4 oz (120 ml) sanitizer

7. Use a soft-bristle brush or sponge (NOT a wire brush) to carefully clean the parts.

 **Warning**

Do not mix Cleaner and Sanitizer solutions together. It is a violation of Federal law to use these solutions in a manner inconsistent with their labeling.

 **Caution**

Do not immerse the water pump motor in the cleaning or sanitizing solution.

8. Use the solution and a brush to clean the top, sides, and bottom evaporator extrusions; the inside of the ice machine panels; and the entire inside of the bin.

NOTE: Do not rinse sanitized components.

9. Install the removed parts.
10. Turn on the water and electrical supply.

## Removal from Service/Winterization

### GENERAL

Special precautions must be taken if the ice machine is to be removed from service for an extended period of time or exposed to ambient temperatures of 32°F (0°C) or below.



### Caution

If water is allowed to remain in the ice machine in freezing temperatures, severe damage to some components could result. Damage of this nature is not covered by the warranty.

Follow the applicable procedure below.

### SELF-CONTAINED AIR-COOLED ICE MACHINES

1. Disconnect the electric power at the circuit breaker or the electric service switch.
2. Turn off the water supply.
3. Remove the water from the water trough.
4. Disconnect and drain the incoming ice-making water line at the rear of the ice machine.
5. Blow compressed air in both the incoming water and the drain openings in the rear of the ice machine until no more water comes out of the inlet water lines or the drain.
6. Make sure water is not trapped in any of the water lines, drain lines, distribution tubes, etc.

## WATER-COOLED ICE MACHINES

1. Perform steps 1-6 under “Self-contained Air-cooled Ice Machines” on page 77.
2. Disconnect the incoming water and drain lines from the water-cooled condenser.
3. Insert a large screwdriver between the bottom spring coils of the water regulating valve. Pry upward to open the valve.

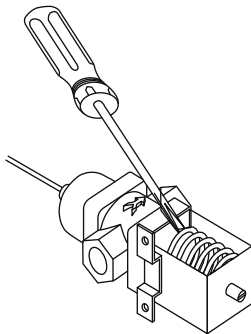

SV1624

### **Pry Open the Water Regulating Valve**

4. Hold the valve open and blow compressed air through the condenser until no water remains.

# Operation

---

## QM45/Q130/Q170/Q210/Q270

### INITIAL START-UP OR START-UP AFTER AUTOMATIC SHUT-OFF

#### 1. Pressure Equalization

Before the compressor starts the hot gas valve is energized for 15 seconds to equalize pressures during the initial refrigeration system start-up.

#### 2. Refrigeration System Start-up

The compressor starts after the 15-second pressure equalization, and remains on throughout the entire Freeze and Harvest Sequences. The hot gas valve remains on for 5 seconds during initial compressor start-up and then shuts off.

At the same time the compressor starts, the condenser fan motor (air-cooled models) is supplied with power throughout the entire Freeze and Harvest Sequences. The fan motor is wired through a fan cycle pressure control, therefore it may cycle on and off. (The compressor and condenser fan motor are wired through the relay. As a result, any time the relay coil is energized, the compressor and fan motor are supplied with power.)

### FREEZE SEQUENCE

#### 3. Prechill

The compressor is on for 30 seconds prior to water flow to prechill the evaporator.

#### 4. Freeze

The water pump starts after the 30-second prechill. An even flow of water is directed across the evaporator and into each cube cell, where it freezes.

When sufficient ice has formed, the water flow (not the ice) contacts the ice thickness probe. After approximately 7 seconds of continual water contact, the Harvest Sequence is initiated. The ice machine cannot initiate a Harvest Sequence until a 6-minute freeze time has been surpassed.

## **HARVEST SEQUENCE**

### **5. Harvest**

The water pump de-energizes stopping flow over the evaporator. The rising level of water in the sump trough diverts water out of the overflow tube, purging excess minerals from the sump trough. The hot gas valve also opens to divert hot refrigerant gas into the evaporator.

The refrigerant gas warms the evaporator causing the cubes to slide, as a sheet, off the evaporator and into the storage bin. The sliding sheet of cubes contacts the ice damper, opening the bin switch.

The momentary opening and re-closing of the bin switch terminates the Harvest Sequence and returns the ice machine to the Freeze Sequence (steps 3 - 4).

## **AUTOMATIC SHUT-OFF**

### **6. Automatic Shut-off**

When the storage bin is full at the end of a harvest sequence, the sheet of cubes fails to clear the ice damper and will hold it down. After the ice damper is held open for 7 seconds, the ice machine shuts off. The ice machine remains off for 3 minutes before it can automatically restart.

The ice machine remains off until enough ice has been removed from the storage bin to allow the ice to fall clear of the damper. As the ice damper swings back to the operating position, the bin switch re-closes and the ice machine restarts (steps 1 - 2), provided the 3 minute delay period is complete.



## ENERGIZED PARTS CHART

### Q130/Q170/Q210/Q270/QM45

### Self-Contained Ice Machines

ICE MAKING SEQUENCE OF OPERATION	Control Board Relays			Relay		Length of Time
	1 Water Pump	2 Hot Gas Valve	3 Relay Coil	3A Compressor	3B Compressor Fan Motor*	
<b>Initial Start-up</b>						
1. Water purge	off	on	off	off	off	15 seconds
2. Refrigeration System Start-up	off	on	on	on	on	5 seconds
<b>Freeze Sequence</b>						
3. Pre chill	off	off	on	on	on	30 seconds
4. Freeze	on	off	on	on	on	Until 7 sec. Water contact w/ice thickness probe

\* Condenser Fan Motor: The fan motor is wired through a fan cycle pressure control; therefore, it may cycle on and off.

ICE MAKING SEQUENCE OF OPERATION	Control Board Relays			Relay		Length of Time
	1 Water Pump	2 Hot Gas Valve	3 Relay Coil	3A Compressor	3B Condenser Fan Motor*	
Harvest Sequence 5. Harvest	off	on	on	on	on	Bin switch activation
Automatic Shut-off 6. Auto Shut-off	off	off	off	off	off	Until bin switch re-closes

## **QM20/QM30**

### **INITIAL START-UP OR START-UP AFTER AUTOMATIC SHUT-OFF**

#### **1. Water Purge**

The water fill valve and the hot gas valve are energized for 2.9 minutes (175 seconds). This ensures that the ice making cycle starts with fresh water, and that the refrigerant pressures are equalized prior to refrigeration system start-up.

#### **2. Refrigeration System Start-up**

The compressor starts 2.9 minutes (175 seconds) after the water fill valve and hot gas valve are energized. (The water fill valve and hot gas valve remain energized for 5 seconds during compressor start-up, and then shut off.) The compressor remains on throughout the entire freeze and harvest cycles.

### **FREEZE SEQUENCE**

#### **3. Freeze Cycle**

The condenser fan motor and water pump are energized and remain on throughout the entire freeze cycle. An even flow of water is directed across the evaporator and into each cube cell, where it freezes.

The control system automatically determines the length of the freeze cycle by monitoring the temperature of the refrigeration system liquid line.

## **HARVEST SEQUENCE**

### **4. Harvest Cycle**

The condenser fan motor and water pump de-energize. The water fill valve energizes to purge the water in the water trough. The hot gas valve also energizes at the beginning of the harvest cycle to divert hot refrigerant gas into the evaporator. The hot refrigerant gas warms the evaporator, causing the cubes to slide, as a sheet, off the evaporator and into the ice storage bin.

The control system automatically determines the length of the harvest cycle, based on the temperature of the refrigeration system liquid line at the end of the freeze cycle. At the end of the harvest cycle, the ice machine returns to another freeze cycle (step 3).

## **AUTOMATIC SHUT-OFF**

### **5. Automatic Shut-off**

The level of ice in the ice storage bin controls the ice machine shut-off. When the bin is full, ice cubes contact the bin thermostat bulb holder, which cools down and opens to stop the ice machine. The ice machine remains off until enough ice has been removed from the bin. This causes the thermostat bulb holder to warm and close, restarting the ice machine. When the ice machine restarts, it returns to the start-up sequence (steps 1 – 2).

**ENERGIZED PARTS CHART**  
**QM20/QM30**  
**Self-Contained Ice Machines**

ICE MAKING SEQUENCE OF OPERATION	Control Board Relays			Length of "ON" Time
	1 Compressor	2 Hot Gas Valve Water Fill Valve	3 Water Pump Fan Motor	
<b>Initial Start-up</b>				
1. Water purge	off	on	off	2.9 minutes (175 seconds)
2. Refrigeration System Start-up	on	on	off	5 seconds
3. Freeze Cycle	on	off	on	Automatically determined
4. Harvest Cycle	on	on	off	Automatically determined
5. Auto-shut-off	off	off	off	Until bin thermostat re-closes

# SM50

## INITIAL START-UP OR START-UP AFTER AUTOMATIC SHUT-OFF

### Sequence of Operation

Bin thermostat and the optional drain pump safety switch must be closed before the ice machine will start.

#### 1. Initial Start-up or Start-up After Automatic Shut-off – Water Fill

Before the compressor starts, the water pump, water inlet valve and hot gas valve are energized for about 3 minutes.

#### 2. Refrigeration System Start-up

The compressor starts after the water fill, and remains on throughout the Freeze and Harvest cycles. The hot gas valve remains on for 5 seconds during initial compressor start-up and then shuts off.

At the same time the compressor starts, the condenser fan motor (air-cooled models) is supplied with power. The condenser fan motor will remain energized during the entire freeze cycle.

#### 3. Freeze

The water pump sprays water into the inverted cups. The water freezes layer by layer, until an ice cube forms in each cup. The control system monitors the temperature of the refrigeration system liquid line to determine the length of the freeze cycle.

#### **4. Harvest**

The water pump de-energizes and the water inlet valve energizes to assist harvest and refill the water sump. The hot gas valve opens and the refrigerant gas warms the evaporator allowing the cubes to release from the evaporator and drop into the storage bin.

The control system automatically determines:

- Length of time the ice machine will remain in the harvest cycle
- Whether the condenser fan motor is energized or de-energized during the harvest cycle

At the end of the harvest cycle the ice machine will start another freeze cycle (step 3).

#### **5. Automatic Shut-off**

The level of ice in the ice storage bin controls the ice machine shut-off. When the bin is full, ice cubes contact the bin thermostat bulb holder, which cools down and opens to stop the ice machine. The ice machine remains off until enough ice has been removed from the bin. This causes the thermostat bulb holder to warm and close, restarting the ice machine. When the ice machine restarts, it returns to the start-up sequence (steps 1 – 2).

## ENERGIZED PARTS CHART

### SM50

### Self-contained Ice Machines

SEQUENCE (Relay)	Water Pump Pump (1)	Water Inlet Valve (2)	Harvest Valve (3)	Compressor (4)	Fan Motor (5)	Duration
Initial Start-up/ Start-up after Automatic Shutoff	on	on	on	off	off	175 seconds
Refrigeration System Start-up	on	on	on	on	on	5 seconds
Freeze Cycle	on	off	off	on	on	Automatically determined*
Harvest	off	on	on	on	on or off	Automatically determined*
Automatic Shutoff	off	off	off	off	off	Until bin thermostat Re-closes

\* Liquid line thermistor determines the length of the freeze and harvest cycles. Liquid line temperature also determines fan motor operation during the harvest cycle.



## Operational Checks

### QM45/Q130/Q170/Q210/Q270

#### Siphon System

To reduce mineral build-up and cleaning frequency, the water in the sump trough must be purged during each harvest cycle.

When the water pump de-energizes the level in the water trough rises above the standpipe starting a siphon action. The siphon action stops when the water level in the sump trough drops. When the siphon action stops, the float valve refills the water trough to the correct level.

Follow steps 1 through 6 under water level check to verify the siphon system functions correctly

#### Water Level

Check the water level while the ice machine is in the ice mode and the water pump is running. The correct water level is 1/4" (6.3 mm) to 3/8" (9.5 mm) below the top of the standpipe, a line in the water trough indicates the correct level.

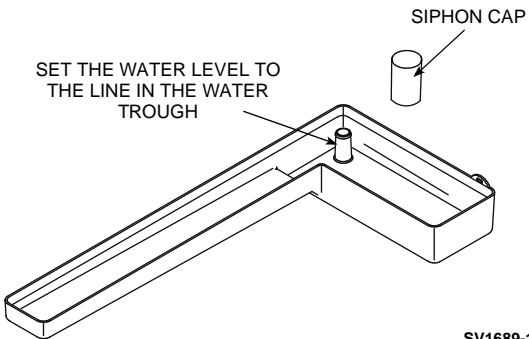

## Water Level Check

The float valve is factory-set for the proper water level. If adjustments are necessary:

1. Verify the ice machine is level.
2. Remove the siphon cap from the standpipe.
3. Place the main ON/OFF/WASH toggle switch to the ON position, and wait until the float valve stops adding water.
4. Adjust the water level to [1/4" to 3/8" (6.3 to 9.5 mm) below the standpipe] the line in the water trough:
  - A. Loosen the two screws on the float valve bracket.
  - B. Raise or lower the float valve assembly as necessary, then tighten the screws.
5. Move the main ON/OFF/WASH toggle switch to the OFF position. The water level in the trough will rise above the standpipe and run down the drain.
6. Replace the siphon cap on the standpipe, and verify water level and siphon action by repeating steps 3 through 5.

## Ice Thickness Check

After a harvest cycle, inspect the ice cubes in the ice storage bin. The ice thickness probe is set to maintain an ice bridge of 1/8" (3.2 mm). If an adjustment is needed, follow the steps below.

1. Turn the ice thickness probe adjustment screw clockwise for a thicker ice bridge, or counterclockwise for a thinner ice bridge.

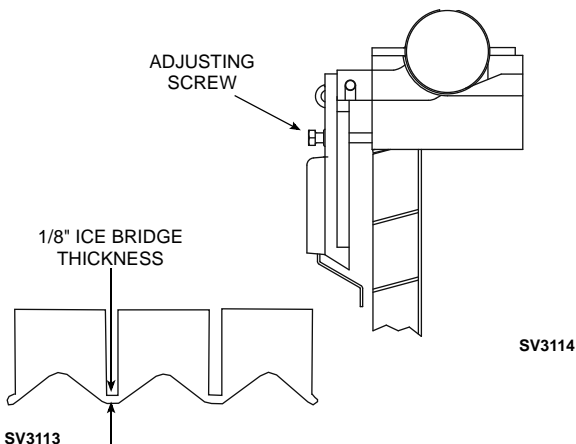

### Ice Thickness Adjustment

2. Make sure the ice thickness probe wire and bracket does not restrict movement of the probe.

## QM20/QM30

Routine adjustments and maintenance procedures outlined in this manual are not covered by the warranty.

### Water Inlet Valve

The water inlet valve energizes in the harvest cycle. The water level will rise and flow out the overflow tube and down the drain. Verify the overflow tube is in place in the water trough. The water level is not adjustable.

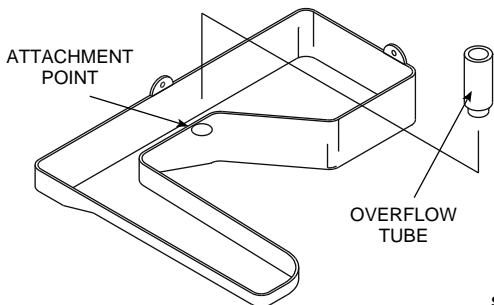

## Ice Thickness Check

QM20/QM30 dice ice cube formation is slightly different from our previous models. Manitowoc ice machines have a unique cube shape. It is normal to have a dimple in the ice cube (a concave indentation in the cube). Ice cubes from the QM20/QM30 may appear to have a slightly larger dimple than other Manitowoc ice cube machines. Therefore, cube size for the QM20/QM30 is determined by measuring the slab weight (the combined weight of all cubes from one harvest cycle). To determine proper slab weight follow the instructions listed below.

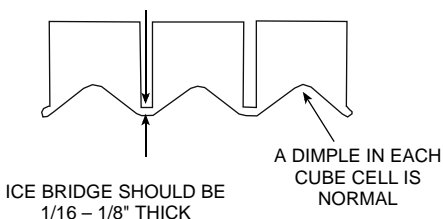

SV3113

### Correct Ice Bridge Thickness

1. Ensure the air filter, front, and back panels are installed properly and close the bin door.
2. During the **third** harvest cycle open the bin door and catch the entire slab of ice.
3. Weigh the ice slab. The combined weight of all cubes from one harvest should weigh between 7 – 9 oz (200 – 270 g). If the slab weight is within this range, the ice machine is working properly and no further action is needed. If the slab weight is not within this range or you desire a slightly thicker or thinner cube, continue to step 4.



### Warning

Do not touch electrical wires. Disconnect power to the ice machine before making any ice thickness adjustments.

4. Remove the air filter.

5. Remove the two screws holding the front panel in place and remove the front cover.
6. Locate the ice thickness control dial on the control board (see below). Turn the dial clockwise for a thicker cube or counterclockwise for a thinner cube.

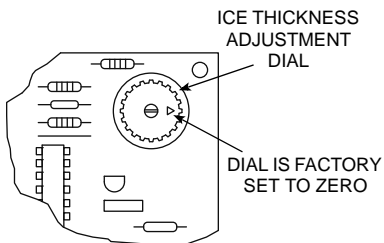

SV1710

### **Ice Thickness Adjustment Dial**

7. Ensure all of the panels and air filter are reinstalled properly and the bin door is closed. Repeat steps 1 – 3.

After completing the procedure above, if you are unable to obtain a sheet of ice weighing 7 – 9 oz (200 – 270 g) contact the Manitowoc Service Department for further assistance.

## **SM50**

Routine adjustments and maintenance procedures outlined in this manual are not covered by the warranty

### **Water Inlet Valve**

The water inlet valve energizes in the harvest cycle. The water level will rise and flow out the overflow tube and down the drain. Verify the overflow tube is in place in the water trough. The water level is not adjustable.

### **Bin Thermostat Adjustment**

The bin thermostat stops the ice machine when the bin is full. Turn the thermostat to the left to decrease the level of ice in bin or to the right to increase the level of ice in bin.

### **Power Button (Green)**

Pressing the "Power" button once will energize the ice machine and green Power light. Pressing the "Power" button a second time will de-energize the ice machine.

### **Automatic Ice Making Light (Blue)**

This light is energized when the ice machine is the ice making position. The light is off when the ice machine is in the clean cycle.

### **Delay Start**

Pressing the "Delay Start" button will initiate a delay cycle. The ice machine will not run until the delay time expires.

- Pressing the button once will energize the 2 hour light and initiate a two hour delay period.
- Pressing the button a second time will energize the 4 hour light and initiate a four hour delay period.
- Pressing the button a third time will energize the 8 hour light and initiate an eight hour delay period.
- Pressing the button a fourth time will cancel the delay cycle.

## **Clean (Green)**

Pressing the “Clean” button will initiate a clean cycle and de-energize the “Automatic Ice Making” light. The clean light will flash during the clean cycle to indicate the proper time to add ice machine cleaner or sanitizer.

## **Replace Filter (Red)**

When the ice machine completes 8000 freeze/harvest cycles the light will energize to indicate the filter needs replacement. Depressing the “Clean” button for 6 seconds will reset the counter and de-energize the light.

## **Safety Timers**

The control board has the following non-adjustable safety timers:

- Initial cycle is 5 minutes longer than subsequent cycles.
- The ice machine is locked into the freeze cycle for 10 minutes (15 minutes initial cycle) before a harvest cycle can be initiated.
- The maximum freeze time is 120 minutes at which time the control board automatically initiates a harvest cycle (step 4).
- The maximum harvest time is 5 minutes at which time the control board automatically starts a freeze cycle.



## Cube Weight Adjustment

The cube weight can be increased from the factory setting by adjusting the finish time.

### ADDITIONAL FINISHING TIME CHECK

1. Press and hold the power button for 5 seconds.
2. Count the flashes on the Automatic Ice Making light. The light will flash once for each additional minute of freeze cycle time.

### ADJUSTING FINISHING TIME

Adjust in 1 minute increments and allow the ice machine to run several freeze/harvest cycles, then inspect the ice cubes. If a heavier cube weight is desired add another minute of freeze time and repeat the process.

1. Press and hold the "Power" button.
2. Press and release the "Clean" button once for each additional minute of freeze cycle time desired.
3. Five minutes is the maximum additional freeze time that can be added. Pressing the clean button 6 times will reset the finishing time to zero additional minutes.

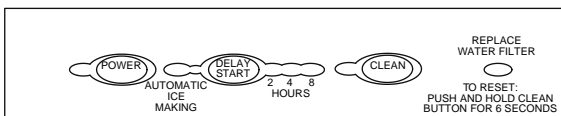

## SM050 Control Panel

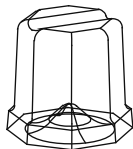

## SM050 Ice Cube

**This Page Intentionally Left Blank**

# Troubleshooting

---

## QM45/Q130/Q170/Q210/Q270

### DIAGNOSING AN ICE MACHINE THAT WILL NOT RUN



#### Warning

High (line) voltage is applied to the control board (terminals #2 and #4) at all times. Removing control board fuse or moving the toggle switch to OFF will not remove the power supplied to the control board.

1. Verify primary voltage is supplied to ice machine and the fuse/circuit breaker is closed.
2. Verify control board fuse is okay.
3. If the bin switch light functions, the fuse is okay.
4. Verify the bin switch functions properly. A defective bin switch can falsely indicate a full bin of ice.
5. Verify ON/OFF/WASH toggle switch functions properly. A defective toggle switch may keep the ice machine in the OFF mode.
6. Verify low DC voltage is properly grounded. Loose DC wire connections may intermittently stop the ice machine.
7. Replace the control board.
8. Be sure Steps 1 – 5 were followed thoroughly. Intermittent problems are not usually related to the control board.

## DIAGNOSING ICE THICKNESS CONTROL CIRCUITRY

### Ice Machine Does Not Cycle Into Harvest when Water Contacts the Ice Thickness Control Probe

**Step 1** Bypass the freeze time lock-in feature by moving the ON/OFF/WASH switch to OFF and back to ON. Wait until the water starts to flow over the evaporator.

**Step 2** Clip the jumper wire to the ice thickness probe and any cabinet ground.

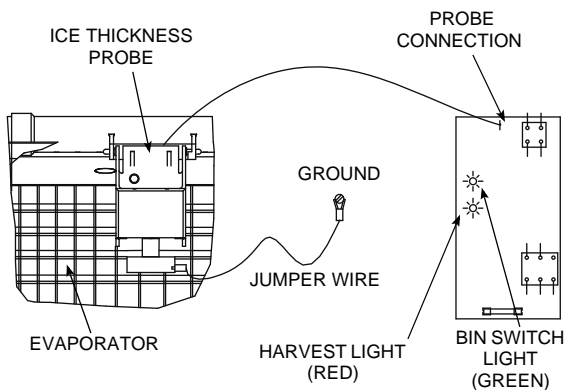

SV1592I

Step 2 Jumper wire connected from probe to ground	
Monitoring Harvest Light	Correction
The harvest light comes on, and 6-10 seconds later, ice machine cycles from freeze to harvest.	The ice thickness control circuitry is functioning properly. Do not change any parts.
The harvest light comes on but the ice machine stays in the freeze sequence.	The ice control circuitry is functioning properly. The ice machine is in a six minute freeze time lock-in. Verify Step 1 of this procedure was followed correctly.
The harvest light does not come on.	Proceed to Step 3.

**Step 3** Disconnect the ice thickness probe from the control board terminal. Clip the jumper wire to the terminal on the control board and any cabinet ground. Monitor the harvest light.

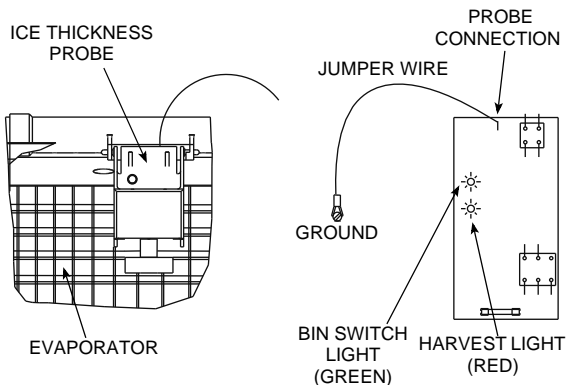

SV1592J

<b>Step 3 Jumper wire connected from control board terminal to ground</b>	
<b>Monitoring Harvest Light</b>	<b>Correction</b>
The harvest light comes on, and 6-10 seconds later, ice machine cycles from freeze to harvest.	The ice thickness probe is causing the malfunction.
The harvest light comes on but the ice machine stays in the freeze sequence.	The control circuitry is functioning properly. The ice machine is in a six-minute freeze time lock-in (verify step 1 of this procedure was followed correctly).
The harvest light does not come on.	The control board is causing the malfunction.

## Ice Machine Cycles Into Harvest Before Water Contact with the Ice Thickness Probe

**Step 1** Bypass the freeze time lock-in feature by moving the ON/OFF/WASH switch to OFF and back to ON. Wait until the water starts to flow over the evaporator, then monitor the harvest light.

**Step 2** Disconnect the ice thickness probe from the control board terminal.

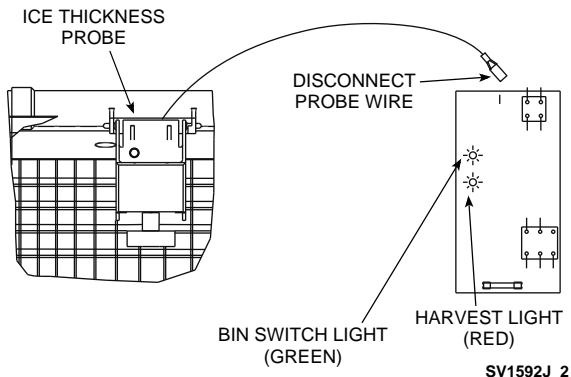

### Step 2 Disconnect probe from control board terminal.

Monitoring Harvest Light	Correction
The harvest light stays off and the ice machine remains in the freeze sequence.	The ice thickness probe is causing the malfunction. Verify that the Ice Thickness probe is adjusted correctly.
The harvest light comes on, and 6-10 seconds later, the ice machine cycles from freeze to harvest.	The control board is causing the malfunction.

## ICE PRODUCTION CHECK

The amount of ice a machine produces directly relates to the operating water and air temperatures. This means an ice machine with a 70°F (21.2°C) ambient temperature and 50°F (10.0°C) water produces more ice than the same ice machine with 90°F (32.2°C) ambient and 70°F (21.2°C) water.

- Determine the ice machine operating conditions:  
 Air temp entering condenser: \_\_\_\_°  
 Air temp around ice machine: \_\_\_\_°  
 Water temp entering sump trough: \_\_\_\_°
- Refer to the appropriate 24-Hour Ice Production Chart. Use the operating conditions determined in Step 1 to find published 24 hr. ice production: \_\_\_\_  
 Times are in minutes.  
 Example: 1 min., 15 sec. converts to 1.25 min.  
 (15 seconds ÷ 60 seconds = .25 minutes)  
 Weights are in pounds.  
 Example: 2 lb., 6 oz. converts to 2.375 lb.  
 (6 oz. ÷ 16 oz. = .375 lb.)
- Perform an ice production check using the formula below.

1. _____	+	_____	=	_____
Freeze Time		Harvest Time		Total Cycle Time
2. <u>1440</u>	÷	_____	=	_____
Mins in 24 hrs		Total Cycle Time		Cycles Per Day
3. _____	x	_____	=	_____
Weight of One Harvest		Cycles Per Day		Actual 24 Hr Production

Weighing the ice is the only 100% accurate check. However, if the ice pattern is normal and the 1/8" (.44 cm) thickness is maintained, the ice slab weights listed with the 24-Hour Ice Production Charts may be used.

- Compare the results of step 3 with step 2. Ice production is normal when these numbers match closely. If they match closely, determine if:  
 Another larger ice machine is required.  
 Relocating the existing equipment to lower the load conditions is required.

Contact the local Manitowoc distributor for information on available options and accessories.

## **INSTALLATION AND VISUAL INSPECTION CHECKLIST**

### ***Ice machine is not level***

- Level the ice machine

### ***Condenser is dirty***

- Clean the condenser

### ***Water filtration is plugged (if used)***

- Install a new water filter

### ***Water drains are not run separately and/or are not vented***

- Run and vent drains according to the Installation Manual



## **WATER SYSTEM CHECKLIST**

A water-related problem often causes the same symptoms as a refrigeration system component malfunction.

Example: A water dump valve leaking during the freeze cycle, a system low on charge, and a starving TXV have similar symptoms.

Water system problems must be identified and eliminated prior to replacing refrigeration components.

### ***Water area (evaporator) is dirty***

- Clean as needed

### ***Water inlet pressure not between 20 and 80 psig (1–5 bar, 138–552 kPa)***

- Install a water regulator valve or increase the water pressure

### ***Incoming water temperature is not between 35°F (1.7°C) and 90°F (32.2°C)***

- If too hot, check the hot water line check valves in other store equipment

### ***Water filtration is plugged (if used)***

- Install a new water filter

### ***Vent tube is not installed on water outlet drain***

- See Installation Instructions

### ***Hoses, fittings, etc., are leaking water***

- Repair/replace as needed

### ***Water float valve is stuck open or closed***

- Clean/replace as needed

### ***Water is spraying out of the sump trough area***

- Stop the water spray

### ***Uneven water flow across the evaporator***

- Clean the ice machine

### ***Water is freezing behind the evaporator***

- Correct the water flow

### ***Plastic extrusions and gaskets are not secured to the evaporator***

- Remount/replace as needed

## ICE FORMATION PATTERN

Evaporator ice formation pattern analysis is helpful in ice machine diagnostics.

Analyzing the ice formation pattern alone cannot diagnose an ice machine malfunction. However, when this analysis is used along with Manitowoc's Refrigeration System Operational Analysis Table, it can help diagnose an ice machine malfunction.

Any number of problems can cause improper ice formation.

Example: An ice formation that is "extremely thin at the outlet" could be caused by a hot water supply, water leaking out the overflow pipe, a faulty water float valve, a low refrigerant charge, etc.



Q130

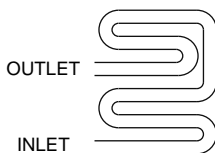

Q170/Q210/Q270

### Examples of Evaporator Tubing Routing

#### Normal Ice Formation

Ice forms across the entire evaporator surface.

At the beginning of the Freeze cycle, it may appear that more ice is forming on the inlet of the evaporator than at the outlet. At the end of the Freeze cycle, ice formation at the outlet will be close to, or just a bit thinner than, ice formation at the inlet. The dimples in the cubes at the outlet of the evaporator may be more pronounced than those at the inlet. This is normal.

If ice forms uniformly across the evaporator surface, but does not do so in the proper amount of time, this is still considered a normal ice fill pattern.

### **Extremely Thin at Evaporator Outlet**

There is no ice, or a considerable lack of ice formation on the outlet of the evaporator.

Examples: No ice at all at the outlet of the evaporator, but ice forms at the inlet half of the evaporator. Or, the ice at the outlet of the evaporator reaches the correct thickness, but the outlet of the evaporator already has 1/2" to 1" of ice formation.

Possible cause: Water loss, low on refrigerant, starving TXV, hot water supply, faulty float valve, etc.

### **Extremely Thin at Evaporator Inlet**

There is no ice, or a considerable lack of ice formation at the inlet of the evaporator. Examples: The ice at the outlet of the evaporator reaches the correct thickness, but there is no ice formation at all at the inlet of the evaporator.

Possible cause: Insufficient water flow, flooding TXV, etc.

### **Spotty Ice Formation**

There are small sections on the evaporator where there is no ice formation. This could be a single corner, or a single spot in the middle of the evaporator. This is generally caused by loss of heat transfer from the tubing on the backside of the evaporator.

### **No Ice Formation**

The ice machine operates for an extended period, but there is no ice formation at all on the evaporator.

Possible cause: Water float valve, water pump, starving expansion valve, low refrigerant charge, compressor, etc.

## **SAFETY LIMIT FEATURE**

In addition to the standard safety controls, your Manitowoc ice machine features built-in safety limits that will stop the ice machine if conditions arise which could cause a major component failure.

Before calling for service, re-start the ice machine using the following procedure:

1. Move the ON/OFF/WASH switch to OFF and then back to ON.
2. If the safety limit feature has stopped the ice machine, it will restart after a short delay. Proceed to step 4.
3. If the ice machine does not restart, see "Ice machine does not operate".
4. Allow the ice machine to run to determine if the condition is reoccurring.
  - A. If the ice machine stops again, the condition has reoccurred. Call for service.
  - B. If the ice machine continues to run, the condition has corrected itself. Allow the ice machine to continue running.

## Safety Limits

In addition to standard safety controls, the control board has two built in safety limit controls which protect the ice machine from major component failures.

**Safety Limit #1:** If the freeze time reaches 60 minutes, the control board automatically initiates a harvest cycle. 3 cycles outside the time limit = 1 hour Stand-by Mode.

**Safety Limit #2:** If the harvest time reaches 3.5 minutes, the control board automatically returns the ice machine to the freeze cycle. 3 cycles outside the time limit = Safety Limit (must be MANUALLY reset).

**Safety Limit Stand-by Mode:** The first time a safety limit shut down occurs, the ice machine turns off for 60 minutes (Stand-by Mode). The ice machine will then automatically restart to see if the problem reoccurs. During the Stand-by Mode the harvest light will be flashing continuously and a safety limit indication can be viewed. If the same safety limit is reached a second time (the problem has reoccurred), the ice machine will initiate a safety limit shut down and remain off until it is manually restarted. During a safety limit shut down the harvest light will be flashing continuously.

**Determining Which Safety Limit Stopped the Ice Machine:** When a safety limit condition causes the ice machine to stop, the harvest light on the control board continually flashes on and off. Use the following procedures to determine which safety limit has stopped the ice machine.

1. Move the toggle switch to OFF.
2. Move the toggle switch back to ON.
3. Watch the harvest light. It will flash one or two times, corresponding to safety limits 1 and 2, to indicate which safety limit stopped the ice machine.

After safety limit indication, the ice machine will restart and run until a safety limit is exceeded again.

## Safety Limit Notes

- A safety limit indication is completed before the water pump starts. Water contacting the ice thickness probe in the freeze cycle will cause the harvest light to flash. Do not mistake a harvest light flashing in the freeze cycle with a safety limit indication.
- A continuous run of 100 harvests automatically erases the safety limit code.
- The control board will store and indicate only one safety limit – the last one exceeded.
- If the toggle switch is moved to the OFF position and then back to the ON position prior to reaching the 100-harvest point, the last safety limit exceeded will be indicated.
- If the harvest light did not flash prior to the ice machine restarting, then the ice machine did not stop because it exceeded a safety limit.

## ANALYZING WHY SAFETY LIMITS MAY STOP THE ICE MACHINE

According to the refrigeration industry, a high percentage of compressor failure is a result of external causes. These can include flooding or starving expansion valves, dirty condensers, water loss to the ice machine, etc. The safety limits protect the ice machine (primarily the compressor) from external failures by stopping ice machine operation before major component damage occurs.

The safety limit system is similar to a high-pressure cutout control. It stops the ice machine, but does not tell what is wrong. The service technician must analyze the system to determine what caused the high-pressure cutout, or a particular safety limit, to stop the ice machine.

The safety limits are designed to stop the ice machine prior to major component failures, most often a minor problem or something external to the ice machine. This may be difficult to diagnose, as many external problems occur intermittently.

**Example:** An ice machine stops intermittently on safety limit #1 (long freeze times). The problem could be a low ambient temperature at night, a water pressure drop; the water is turned off one night a week, etc.

When a high-pressure cutout or a safety limit stops the ice machine, they are doing what they are supposed to do. That is, stopping the ice machine before a major component failure occurs.

Refrigeration and electrical component failures may also trip a safety limit. Eliminate all electrical components and external causes first. If it appears that the refrigeration system is causing the problem, use Manitowoc's Refrigeration System Operational Analysis Table, along with detailed charts, checklists, and other references to determine the cause.

## **Safety Limit Checklist**

The following checklists are designed to assist the service technician in analysis. However, because there are many possible external problems, do not limit your diagnosis to only the items listed.

### **Safety Limit #1**

**Freeze time exceeds 60 minutes for 6 consecutive freeze cycles.**

Possible Cause Checklist

#### ***Improper installation***

- Refer to “Installation and Visual Inspection Checklist” on page 104

#### ***Water System***

- Water Level set too high (water escaping through over flow tube)
- Low water pressure (20 psig min.)
- High water pressure (80 psig max.)
- High water temperature (90°F/32.2°C max.)
- Clogged water distribution tube
- Dirty/defective float valve
- Defective water pump

#### ***Electrical System***

- Ice thickness probe out of adjustment
- Harvest cycle not initiated electrically
- Contactor not energizing
- Compressor electrically non-operational
- Restricted condenser air flow
- High inlet air temperature (110°F/43.3°C max.)
- Condenser discharge air re-circulation
- Dirty condenser fins
- Defective fan cycling control
- Defective fan motor
- Low water pressure (20 psig min.)
- High water temperature (90°F/32.2°C max.)
- Dirty condenser



## ***Refrigeration System***

- Non-Manitowoc components
- Improper refrigerant charge
- Defective compressor
- TXV starving or flooding (check bulb mounting)
- Non-condensable in refrigeration system
- Plugged or restricted high side refrigerant lines or component
- Defective hot gas valve

## **Safety Limit #2**

### **Harvest time exceeds 3.5 minutes for 6 Consecutive harvest cycles.**

#### Possible Cause Checklist

##### ***Improper installation***

- Refer to “Installation and Visual Inspection Checklist” on page 104.

##### ***Water System***

- Water area (evaporator) dirty
- Dirty/defective water dump valve
- Vent tube not installed on water outlet drain
- Water freezing behind evaporator
- Plastic extrusions and gaskets not securely mounted to the evaporator
- Low water pressure (20 psig min.)
- Loss of water from sump area
- Clogged water distribution tube
- Dirty/defective float valve
- Defective water pump

##### ***Electrical system***

- Ice thickness probe out of adjustment
- Ice thickness probe dirty
- Bin switch defective
- Premature harvest

##### ***Refrigeration system***

- Non-Manitowoc components
- Improper refrigerant charge
- Defective hot gas valve
- TXV flooding (check bulb mounting)
- Defective fan cycling control

## ANALYZING DISCHARGE PRESSURE

### Q130/Q170/Q210/Q270 Ice Machines Only

1. Determine the ice machine operating conditions:  
Air temp. entering condenser \_\_\_\_\_  
Air temp. around ice machine \_\_\_\_\_  
Water temp. entering sump trough \_\_\_\_\_
2. Refer to "Cycle Times, 24 Hr. Ice Production and Refrigerant Pressure Charts" on page 203 for ice machine being checked.

Use the operating conditions determined in step 1 to find the published normal discharge pressures.

Freeze Cycle \_\_\_\_\_

Harvest Cycle \_\_\_\_\_

3. Perform an actual discharge pressure check.

	<b>Freeze Cycle PSIG</b>	<b>Harvest Cycle PSIG</b>
Beginning of Cycle	_____	_____
Middle of Cycle	_____	_____
End of Cycle	_____	_____

4. Compare the actual discharge pressure (step 3) with the published discharge pressure (step 2).

The discharge pressure is normal when the actual pressure falls within the published pressure range for the ice machine's operating conditions. It is normal for the discharge pressure to be higher at the beginning of the freeze cycle (when load is greatest), then drop through out the freeze cycle.

## **Discharge Pressure High Checklist**

### ***Improper Installation***

- Refer to “Installation and Visual Inspection Checklist” on page 104.

### ***Restricted Condenser Air Flow***

- High inlet air temperature
- Condenser discharge air re-circulation
- Dirty condenser fins
- Defective fan cycling control
- Defective fan motor

### ***Improper Refrigerant Charge***

- Overcharged
- Non-condensable in system
- Wrong type of refrigerant

### ***Other***

- Non-Manitowoc components in system
- High side refrigerant lines/component
- Restricted (before mid-condenser)

## **Freeze Cycle Discharge Pressure Low Checklist**

### ***Improper Installation***

- Refer to “Installation and Visual Inspection Checklist” on page 104.

### ***Improper Refrigerant Charge***

- Undercharged
- Wrong type of refrigerant

### ***Other***

- Non-Manitowoc components in system
- High side refrigerant lines/component restricted (before mid-condenser)
- Defective fan cycle control

NOTE: Do not limit your diagnosis to only the items listed in the checklists.

## **ANALYZING SUCTION PRESSURE**

### **Q130/Q170/Q210/Q270 Ice Machines Only**

The suction pressure gradually drops throughout the freeze cycle. The actual suction pressure (and drop rate) changes as the air and water temperature entering the ice machine changes. These variables also determine the freeze cycle times.

To analyze and identify the proper suction pressure drop throughout the freeze cycle, compare the published suction pressure to the published freeze cycle time.

**NOTE:** Analyze discharge pressure before analyzing suction pressure. High or low discharge pressure may be causing high or low suction pressure.

## Procedure

Step																												
<p>1. Determine the ice machine operating conditions.</p> <p><i>Example:</i> <i>Air temp. entering condenser: 90°F/32.2°C</i> <i>Air temp. around ice machine: 80°F/26.7°C</i> <i>Water temp. entering water fill valve: 70°F/21.1°C</i></p>																												
<p>2A. Refer to "Cycle Time" and "Operating Pressure" charts for ice machine model being checked. Using operating conditions from Step 1, determine published freeze cycle time and published freeze cycle suction pressure.</p> <p><i>Example:</i> <i>Published freeze cycle time: 14.8 - 15.9 minutes</i> <i>Published freeze cycle suction pressure: 65 - 26 psig</i></p>																												
<p>2B. Compare the published freeze cycle time and published freeze cycle suction pressure. Develop a chart.</p> <p><i>Example:</i></p> <table><thead><tr><th colspan="7"><u>Published Freeze Cycle Time (minutes)</u></th></tr></thead><tbody><tr><td style="text-align: center;">1</td><td style="text-align: center;">2</td><td style="text-align: center;">4</td><td style="text-align: center;">7</td><td style="text-align: center;">10</td><td style="text-align: center;">12</td><td style="text-align: center;">14</td></tr><tr><td style="text-align: center;"> </td><td style="text-align: center;"> </td><td style="text-align: center;"> </td><td style="text-align: center;"> </td><td style="text-align: center;"> </td><td style="text-align: center;"> </td><td style="text-align: center;"> </td></tr><tr><td style="text-align: center;">65</td><td style="text-align: center;">55</td><td style="text-align: center;">47</td><td style="text-align: center;">39</td><td style="text-align: center;">34</td><td style="text-align: center;">30</td><td style="text-align: center;">26</td></tr></tbody></table> <p><u>Published Freeze Cycle Suction Pressure (psig)</u> <i>In the example, the proper suction pressure should be approximately 39 psig at 7 minutes; 30 psig at 12 minutes; etc.</i></p>	<u>Published Freeze Cycle Time (minutes)</u>							1	2	4	7	10	12	14								65	55	47	39	34	30	26
<u>Published Freeze Cycle Time (minutes)</u>																												
1	2	4	7	10	12	14																						
65	55	47	39	34	30	26																						
<p>3. Perform an actual suction pressure check at the beginning, middle and end of the freeze cycle. Note the times at which the readings are taken.</p> <p><i>Example:</i> <i>Manifold gauges were connected to the example ice machine and suction pressure readings taken as follows: _____ PSIG</i> <i>Beginning of Freeze cycle: 79 (at 1 min.)</i> <i>Middle of freeze cycle: 48 (at 7 min.)</i> <i>End of freeze cycle: 40 (at 14 min.)</i></p>																												
<p>4. Compare the actual freeze cycle suction pressure (Step 3) to the published freeze cycle time and pressure comparison (Step 2B). Determine if the suction pressure is high, low or acceptable.</p> <p><i>Example:</i> <i>In this example, the suction pressure is considered high throughout the freeze cycle. It should have been:</i> <i>Approximately 65 psig (at 1 minute) – not 79</i> <i>Approximately 39 psig (at 7 minutes) – not 48</i> <i>Approximately 26 psig (at 14 minutes) – not 40</i></p>																												

## **Suction Pressure High Checklist**

### ***Improper Installation***

- Refer to “Installation and Visual Inspection Checklist” on page 104.

### ***Discharge Pressure***

- Discharge pressure is too high, and is affecting suction pressure, refer to “Discharge Pressure High Checklist” on page 150.

### ***Improper Refrigerant Charge***

- Overcharged
- Wrong type of refrigerant
- Non-condensables in system

### ***Other***

- Non-Manitowoc components in system
- Hot gas valve leaking
- TXV flooding (check bulb mounting)
- Defective compressor

## **Suction Pressure Low Checklist**

### ***Improper Installation***

- Refer to “Installation and Visual Inspection Checklist” on page 104.

### ***Discharge Pressure***

- Discharge pressure is too low, and is affecting suction pressure, refer to “Freeze Cycle Discharge Pressure Low Checklist”

### ***Improper Refrigerant Charge***

- Undercharged
- Wrong type of refrigerant

### ***Other***

- Non-Manitowoc components in system
- Improper water supply over evaporator refer to “Water System Checklist” on page 105.
- Loss of heat transfer from tubing on back side of evaporator
- Restricted/plugged liquid line drier
- Restricted/plugged tubing in suction side of refrigeration system
- TXV starving

NOTE: Do not limit your diagnosis to only the items listed in the checklists.



## **HOT GAS VALVE**

### **General**

The hot gas valve is an electrically operated valve that opens when energized, and closes when de-energized.

### **Normal Operation**

The valve is de-energized (closed) during the freeze cycle and energized (open) during the harvest cycle. The valve is positioned between the receiver and the evaporator and performs two functions:

1. Prevents refrigerant from entering the evaporator during the freeze cycle.

The hot gas valve is not used during the freeze cycle. The hot gas valve is de-energized (closed) preventing refrigerant flow from the receiver into the evaporator.

2. Allows refrigerant vapor to enter the evaporator in the harvest cycle.

During the harvest cycle, the hot gas valve is energized (open) allowing refrigerant gas from the discharge line of the compressor to flow into the evaporator. The heat is absorbed by the evaporator and allows release of the ice slab.

Exact pressures vary according to ambient temperature and ice machine model. Harvest pressures (for Q130/Q170/Q210/Q270 ice machines) can be found in the Cycle Time/24 Hour Ice Production/ Refrigerant Pressure Charts in this book.

## Hot Gas Valve Analysis

The valve can fail in two positions:

- Valve will not open in the harvest cycle.
- Valve remains open during the freeze cycle.

### VALVE WILL NOT OPEN IN THE HARVEST CYCLE

Although the circuit board has initiated a harvest cycle, the evaporator temperature remains unchanged from the freeze cycle.

#### **Caution**

Coil must be seated 100% on solenoid to function correctly. Install coil with a twisting motion to properly seat.

### VALVE REMAINS OPEN IN THE FREEZE CYCLE:

Symptoms of a hot gas valve remaining partially open during the freeze cycle can be similar to symptoms of an expansion valve, float valve or compressor problem. Symptoms are dependent on the amount of leakage in the freeze cycle.

A small amount of leakage will cause increased freeze times and an ice fill pattern that is “Thin at the Outlet”, but fills in at the end of the cycle.

As the amount of leakage increases the length of the freeze cycle increases and the amount of ice at the outlet of the evaporator decreases.

Refer to the Parts Manual for proper valve application. If replacement is necessary, use only “original” Manitowoc replacement parts.

Use the following procedure and table to help determine if a hot gas valve is remaining partially open during the freeze cycle.

1. Wait five minutes into the freeze cycle.
2. Feel the inlet of the hot gas valve(s).

### **Important**

Feeling the hot gas valve outlet or across the hot gas valve itself will not work for this comparison. The hot gas valve outlet is on the suction side (cool refrigerant). It may be cool enough to touch even if the valve is leaking.

3. Feel the compressor discharge line.



### **Warning**

The inlet of the hot gas valve and the compressor discharge line could be hot enough to burn your hand. Just touch them momentarily.

4. Compare the temperature of the inlet of the hot gas valves to the temperature of the compressor discharge line.

<b>Findings</b>	<b>Comments</b>
<p>The inlet of the harvest valve is cool enough to touch and the compressor discharge line is hot.</p> <p><b>Cool &amp; Hot</b></p>	<p>This is normal as the discharge line should always be too hot to touch and the harvest valve inlet, although too hot to touch during harvest, should be cool enough to touch after 5 minutes into the freeze cycle.</p>
<p>The inlet of the harvest valve is hot and approaches the temperature of a hot compressor discharge line.</p> <p><b>Hot &amp; Hot</b></p>	<p>This is an indication something is wrong, as the harvest valve inlet did not cool down during the freeze cycle. If the compressor dome is also entirely hot, the problem is not a harvest valve leaking, but rather something causing the compressor (and the entire ice machine) to get hot.</p>
<p>Both the inlet of the harvest valve and the compressor discharge line are cool enough to touch.</p> <p><b>Cool &amp; Cool</b></p>	<p>This is an indication something is wrong, causing the compressor discharge line to be cool to the touch. This is not caused by a harvest valve leaking.</p>

5. Record your findings on the table.

## COMPARING EVAPORATOR INLET/OUTLET TEMPERATURES

### Q130/Q170/Q210/Q270 Ice Machines Only

The temperatures of the suction lines entering and leaving the evaporator alone cannot diagnose an ice machine. However, comparing these temperatures during the freeze cycle, along with using Manitowoc's Refrigeration System Operational Analysis Table, can help diagnose an ice machine malfunction.

The actual temperatures entering and leaving the evaporator vary by model, and change throughout the freeze cycle. This makes documenting the "normal" inlet and outlet temperature readings difficult. The key to the diagnosis lies in the difference between the two temperatures five minutes into the freeze cycle. These temperatures must be within 7°F (4°C) of each other.

Use this procedure to document freeze cycle inlet and outlet temperatures.

1. Use a quality temperature meter, capable of taking temperature readings on curved copper lines.
2. Attach the temperature meter sensing device to the copper lines entering and leaving the evaporator.

### Important

Do not simply insert the sensing device under the insulation. It must be attached to and reading the actual temperature of the copper line.

3. Wait five minutes into the freeze cycle.
4. Record the temperatures below and determine the difference between them.

_____	_____	_____
Inlet Temperature	Difference must be within 7°F (4°C) at 5 minutes into the freeze cycle	Outlet Temperature

5. Use this with other information gathered on the Refrigeration System Operational Analysis Table to determine the ice machine malfunction.

## **DISCHARGE LINE TEMPERATURE ANALYSIS**

### **Q130/Q170/Q210/Q270 Ice Machines Only**

#### **GENERAL**

Knowing if the discharge line temperature is increasing, decreasing or remaining constant can be an important diagnostic tool. Maximum compressor discharge line temperature on a normally operating ice machine steadily increases throughout the freeze cycle. Comparing the temperatures over several cycles will result in a consistent maximum discharge line temperature.

Ambient air temperatures affect the maximum discharge line temperature.

Higher ambient air temperatures at the condenser = higher discharge line temperatures at the compressor.

Lower ambient air temperatures at the condenser = lower discharge line temperatures at the compressor.

Regardless of ambient temperature, the freeze cycle discharge line temperature will be higher than 150°F (66°C) on a normally operating ice machine.

#### **PROCEDURE**

Connect a temperature probe on the compressor discharge line within 6" (15.2 cm) of the compressor. Observe the discharge line temperature for the last three minutes of the freeze cycle and record the maximum discharge line temperature.

### **Discharge Line Temperature Above 150°F (66°C) at End of Freeze Cycle:**

Ice machines that are operating normally will have consistent maximum discharge line temperatures above 150°F (66°C).

Verify the expansion valve sensing bulb is positioned and secured correctly.

### **Discharge Line Temperature Below 150°F (66°C) at End of Freeze Cycle**

Ice machines that have a flooding expansion valve will have a maximum discharge line temperature that decreases each cycle.

Verify the expansion valve sensing bulb is 100% insulated and sealed airtight. Condenser air contacting an incorrectly insulated sensing bulb will cause overfeeding of the expansion valve.

## **REFRIGERATION COMPONENT DIAGNOSTIC CHART**

### **Q130/Q170/Q210/Q270 Ice Machines Only**

All electrical and water related problems must be corrected before these charts will work properly. These tables must be used with charts, checklists and other references to eliminate refrigeration components not listed and external items and problems that will cause good refrigeration components to appear defective.

The tables list four different defects that may affect the ice machine's operation.

**NOTE:** A low-on-charge ice machine and a starving expansion valve have very similar characteristics and are listed under the same column.



## PROCEDURE

**Step 1** Complete each item individually in the “Operational Analysis” column.

Enter check marks (✓) in the boxes.

Each time the actual findings of an item in the “Operational Analysis” column matches the published findings on the table, enter a check mark.

Example: Freeze cycle suction pressure is determined to be low. Enter a check mark in the “low” box.

Perform the procedures and check all information listed. Each item in this column has supporting reference material.

While analyzing each item separately, you may find an “external problem” causing a good refrigerant component to appear bad. **Correct problems as they are found. If the operational problem is found, it is not necessary to complete the remaining procedures.**

**Step 2** Add the check marks listed under each of the four columns. Note the column number with the highest total and proceed to “Final Analysis.”

NOTE: If two columns have matching high numbers, a procedure was not performed properly and/or supporting material was not analyzed correctly.

## **FINAL ANALYSIS**

The column with the highest number of check marks identifies the refrigeration problem.

### **Column 1 – Hot Gas Valve Leaking**

A leaking hot gas valve must be replaced.

### **Column 2 – Low Charge/TXV Starving**

Normally, a starving expansion valve only affects the freeze cycle pressures, not the harvest cycle pressures. A low refrigerant charge normally affects both pressures. Verify the ice machine is not low on charge before replacing an expansion valve.

Add refrigerant charge in 2 oz. increments as a diagnostic procedure to verify a low charge. (Do not add more than the total charge of refrigerant). If the problem is corrected, the ice machine is low on charge. Find the refrigerant leak.

The ice machine must operate with the nameplate charge. If the leak cannot be found, proper refrigerant procedures must still be followed. Change the liquid line drier, evacuate the system and weigh in the proper charge.

If the problem is not corrected by adding charge, the expansion valve is faulty.

### **Column 3 – TXV Flooding**

A loose or improperly mounted expansion valve bulb causes the expansion valve to flood. Check bulb mounting, insulation, etc., before changing the valve.

### **Column 4 – Compressor**

Replace the compressor and start components. To receive warranty credit, the compressor ports must be properly sealed by crimping and soldering them closed. Old start components must be returned with the faulty compressor.

# REFRIGERATION COMPONENT DIAGNOSTIC CHART

## Q130/Q170/Q210/Q270 Ice Machines Only

Operational Analysis	1	2	3	4
<b>Ice Production</b>	<p>Published 24 hour ice production _____            Calculated (actual) 24 hour ice production _____</p> <p>Note: The ice machine is operating properly if the ice fill patterns is normal and ice production is within 10% of charted capacity.</p>			
<b>Installation and Water system</b>	<p>All installation and water related problems must be corrected before proceeding with chart.</p>			
<b>Ice Formation Pattern</b>	<p>Ice formation is extremely thin on top of evaporator            -or-            No ice formation on entire evaporator</p>	<p>Ice formation is extremely thin on top of evaporator            -or-            No ice formation on entire evaporator</p>	<p>Ice formation is normal            -or-            ice formation is extremely thin on the bottom of the evaporator or            No ice formation on evaporator</p>	<p>Ice formation is normal            -or-            No ice formation on entire evaporator</p>

**Q130/Q170/Q210/Q270 Ice Machines Only  
(continued)**

Operational Analysis	1	2	3	4
<p><b>Safety limits</b> Refer to "Analyzing Safety Limits" to eliminate all non-refrigeration problems.</p>	<p>Stops on <b>safety limit:</b> 1 or 2</p>	<p>Stops on <b>safety limit:</b> 1</p>	<p>Stops on <b>safety limit:</b> 1 or 2</p>	<p>Stops on <b>safety limit:</b> 1</p>
<p><b>Freeze cycle Discharge Pressure</b> _____ Middle _____ End 1 minute</p>	<p>If discharge pressure is High or Low, refer to freeze cycle high or low discharge pressure problem checklist to eliminate problems and/or components not listed on this table before proceeding.</p>			
<p><b>Freeze cycle Suction Pressure</b> _____ Middle _____ End 1 minute</p>	<p>If suction pressure is High or Low refer to freeze cycle high or low suction pressure problem checklist to eliminate problems and/or components not listed on this table before proceeding.</p>			
	<p>Suction pressure is High</p>	<p>Suction pressure is Low</p>	<p>Suction pressure is High</p>	<p>Suction pressure is High</p>

**Q130/Q170/Q210/Q270 Ice Machines Only  
(continued)**

<b>Operational Analysis</b>	<b>1</b>	<b>2</b>	<b>3</b>	<b>4</b>
<p><b>Hot Gas Valve</b></p>	<p>The hot gas valve inlet is <b>HOT</b> and the compressor discharge line is <b>HOT</b></p>	<p>The hot gas valve inlet is <b>COOL</b> and the compressor discharge line is <b>HOT</b></p>	<p>The hot gas valve inlet is <b>COOL</b> and the compressor discharge line is <b>COOL</b></p>	<p>The hot gas valve inlet is <b>COOL</b> and the compressor discharge line is <b>HOT</b></p>
<p><b>Discharge Line Temp.</b> Record freeze cycle discharge line temp at the end of freeze cycle.</p>	<p>Discharge line temp <b>150°F (66°C) or higher</b> at the end of freeze cycle</p>	<p>Discharge line temp <b>150°F (66°C) or higher</b> at the end of freeze cycle</p>	<p>Discharge line temp <b>less than 150°F (66°C)</b> at the end of freeze cycle</p>	<p>Discharge line temp <b>150°F (66°C) or higher</b> at the end of freeze cycle</p>
<p><b>Final Analysis</b> Enter total number of boxes checked in each column.</p>	<p>Hot Gas Valve Leaking</p>	<p>Low On Charge -or- TXV Starving</p>	<p>TXV Flooding</p>	<p>Compressor</p>

## QM20/QM30

### DIAGNOSING AN ICE MACHINE THAT WILL NOT RUN



#### **Warning**

High (line) voltage is applied to the control board (terminals #8 and #2) at all times. Removing control board fuse or moving the toggle switch to OFF will not remove the power supplied to the control board.

1. Verify primary voltage is supplied to ice machine.
2. Verify that the fuse or circuit breaker is closed.
3. Verify control board fuse is OK. If the power light functions, the fuse is OK.
4. Verify ICE/OFF/WASH toggle switch functions properly. A defective toggle switch may keep the ice machine in the OFF mode.
5. Verify the bin thermostat functions properly. A defective bin thermostat can falsely indicate a full bin of ice.
6. Verify low DC voltage is properly grounded. Loose DC wire connections may intermittently stop the ice machine.
7. Replace the control board.
8. Be sure steps 1-6 were followed thoroughly. Intermittent problems are not usually related to the control board.

## REFRIGERATION DIAGNOSTICS

### QM20

The QM20 ice machines have a very small refrigerant charge, 4.59 oz (130 g) and we do not recommend diagnosing the ice machine using refrigerant pressures. For this reason we have not included refrigeration access fittings.

Verify that your water flow is even across the entire evaporator before diagnosing the refrigeration system. Mineral build-up on the evaporator assembly can cause water tracking and an erratic ice fill pattern. Clean with Manitowoc Ice Machine cleaner to remove any mineral build-up before entering the refrigeration system.

The following can be used for diagnostics:

Capillary Tube failures or low refrigerant charge will always result in a starving evaporator.

Assume 86°F (30°C) air temperature 68°F (20°C) water temperature.

Suction line temperature at the compressor will range from 86°F (30°C) three minutes into the cycle to 8°F (-13°C) at the end of the freeze cycle. An obstructed capillary tube or low refrigerant charge will have a suction line temperature higher than normal.

Discharge line temperature at the compressor will range from 168°F (76°C) to 140°F (60°C) through the freeze cycle. An obstructed capillary tube or low refrigerant charge will have a lower discharge line temperature than normal.

Suction line temperature at the compressor will range from 64°F (18°C) to 111°F (44°C) through the harvest cycle. An obstructed capillary tube will not affect suction line temperature range during the harvest cycle. Low refrigerant charge will have a lower temperature than normal.

Discharge line temperature at the compressor will range from 180°F (82°C) to 150°F (60°C) through the harvest cycle. An obstructed capillary tube will not affect discharge line temperature range during the harvest cycle. Low refrigerant charge will have a lower temperature than normal.

Ice fill pattern will vary depending on severity of the obstruction or refrigeration loss. Ice fill patterns will range from no ice on the entire evaporator to thin only at the evaporator outlet (thin at the bottom, thick at the top of the evaporator).

## QM30

The QM30 ice machines have a very small refrigerant charge, 5.78 oz (165 g) and we do not recommend diagnosing the ice machine using refrigerant pressures. For this reason we have not included refrigeration access fittings.

Verify that your water flow is even across the entire evaporator before diagnosing the refrigeration system. Mineral build-up on the evaporator assembly can cause water tracking and an erratic ice fill pattern. Clean with Manitowoc Ice Machine cleaner to remove any mineral build-up before entering the refrigeration system.

The following can be used for diagnostics:

Capillary Tube failures or low refrigerant charge will always result in a starving evaporator.

Assume 86°F (30°C) air temperature 68°F (20°C) water temperature.

Suction line temperature at the compressor will range from 86°F (30°C) three minutes into the cycle to 8°F (-13°C) at the end of the freeze cycle. An obstructed capillary tube or low refrigerant charge will have a suction line temperature higher than normal.

Discharge line temperature at the compressor will range from 168°F (76°C) to 140°F (60°C) through the freeze cycle. An obstructed capillary tube or low refrigerant charge will have a lower discharge line temperature than normal.

Suction line temperature at the compressor will range from 64°F (18°C) to 111°F (44°C) through the harvest cycle. An obstructed capillary tube will not affect suction line temperature range during the harvest cycle. Low refrigerant charge will have a lower temperature than normal.

Discharge line temperature at the compressor will range from 180°F (82°C) to 150°F (60°C) through the harvest cycle. An obstructed capillary tube will not affect discharge line temperature range during the harvest cycle. Low refrigerant charge will have a lower temperature than normal.

Ice fill pattern will vary depending on severity of the obstruction or refrigeration loss. Ice fill patterns will range from no ice on the entire evaporator to thin only at the evaporator outlet (thin at the bottom, thick at the top of the evaporator).



## ICE FORMATION PATTERN

Evaporator ice formation pattern analysis is helpful in ice machine diagnostics.

Analyzing the ice formation pattern alone cannot diagnose an ice machine malfunction. However, when this analysis is used along with Manitowoc's Refrigeration System Operational Analysis Table, it can help diagnose an ice machine malfunction.

Any number of problems can cause improper ice formation.

Example: An ice formation that is "extremely thin at the outlet" could be caused by a hot water supply, water leaking water out the overflow pipe, a faulty water float valve, a low refrigerant charge, etc.

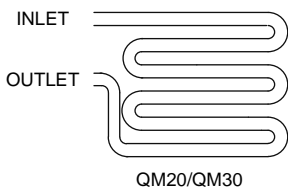

### Evaporator Tubing Routing

## Ice Production Check

The QM20/QM30 dice ice cube formation is slightly different from our previous models. Manitowoc ice machines have a unique cube shape. It is normal to have a dimple in the ice cube (a concave indentation in the cube). Ice cubes from the QM20/QM30 may appear to have a slightly larger dimple than other Manitowoc ice cube machines. Therefore, cube size for the QM20/QM30 is determined by measuring the slab weight (the combined weight of all cubes from one harvest cycle). To determine proper slab weight, follow the instructions listed below.

1. Ensure the air filter, front, and back panels are installed properly and close the bin door.
2. During the **third** harvest cycle open the bin door and catch the entire slab of ice.
3. Weigh the ice slab. The combined weight of all cubes from one harvest should weigh between 7 – 9 oz (200 – 270 g). If the slab weight is within this range, the ice machine is working properly and no further action is needed. If the slab weight is not within this range or you desire a slightly thicker or thinner cube, continue to step 4.

### Warning

Disconnect electric power to the ice machine at the electric switch box before proceeding.

4. Remove the air filter.
5. Remove the two screws holding the front panel in place and remove the front cover.

Locate the ice thickness control dial on the control board (see figure). Turn the dial clockwise for a thicker cube or counter clockwise for a thinner cube.

6. Ensure all of the panels and air filter are reinstalled properly and the bin door is closed. Repeat steps 1 – 3.

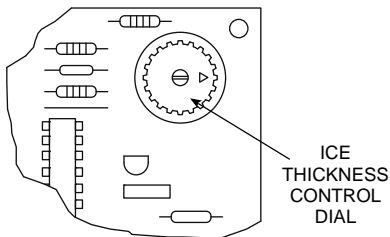

SV1710\_2

## **QM45**

### **ELECTRICAL**

The QM45 electrical sequence of Operation and troubleshooting is identical to the Q130/Q210/Q270. Refer to those models for electrical troubleshooting of:

- Ice machine will not run
- Diagnosing Ice Thickness Control Circuitry
- Ice production check
- Ice formation pattern
- Safety limits

Refer to the following pages for refrigeration diagnostics.

## REFRIGERATION DIAGNOSTICS

### Important:

- DO NOT install a manifold gauge set on the ice machine! Refrigerant pressures are not used to diagnose this ice machine.
- If the ice machine is “slushing” remove the screen from the bottom of the water pump.
- Normal Ice Fill Pattern is less fill on the left side of the evaporator. This occurs because the refrigeration tubing exits the evaporator on the left side.

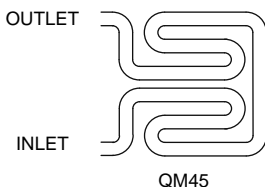

### Evaporator Tubing Routing

#### Procedure

1. Remove siphon cap from siphon tube and verify that the water level is between 1/4 and 3/8 inch (6.4 – 9.5 mm) from the top of the standpipe, a line in the water trough indicates the correct level.

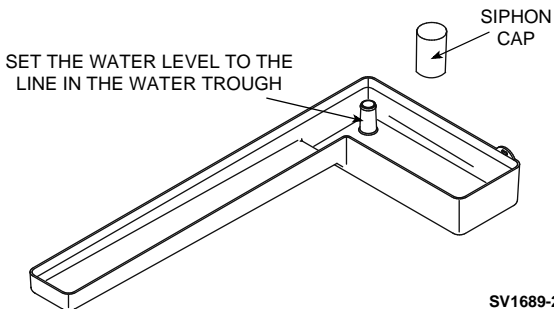

2. Verify that the incoming water pressure is more than 20 psi and less than 80 psi.

3. Verify that the ice thickness probe is properly adjusted.

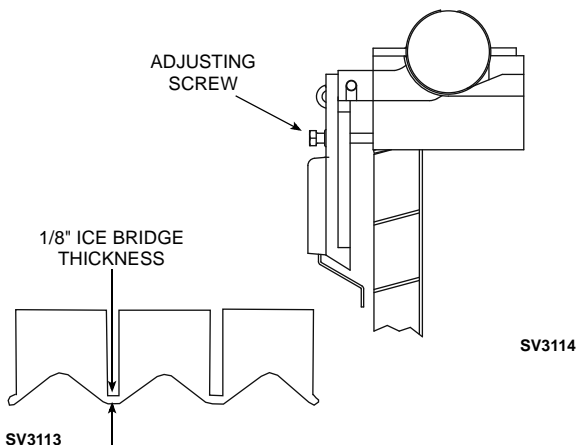

### Ice Thickness Adjustment

4. Verify that the machine has properly sized drain line leaving the machine and that the bin drain is not restricted. Refer to "Drain Connections" on page 31 for installation details.

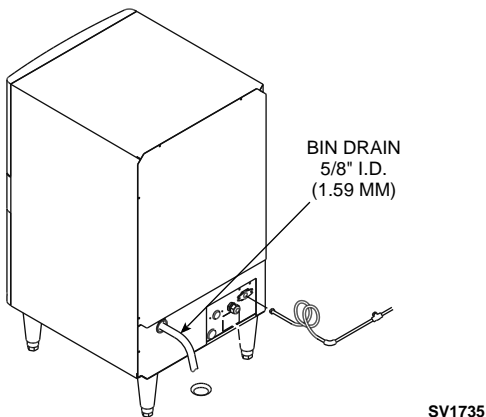

5. Install thermometer thermocouples on Suction and Discharge line:
  - Digital thermometers with remote thermocouples must be used to obtain temperatures
  - Suction and Discharge line thermocouples must be within 3" (76.2 mm) of the compressor
  - Thermocouples must be insulated
  - Doors and all panels must be in place
  - Initial freeze cycle is not used for diagnostics. Start monitoring temperatures 3 minutes into the second freeze cycle.
6. Compare Suction and Discharge temperatures to "QM45 Operating Temperatures" on page 207. The charts list **Normal** suction and discharge temperatures.

## Analysis

Discharge Line Temp	Suction Line Temp	Ice Fill Pattern	Refer to Diagnostics for:
Normal	Normal	Less fill on the left side of the evaporator	This is normal operation
Low (20°F [-7°C] or more)	Low (20°F [-7°C] or more)	Less fill on the left side of the evaporator	Expansion Valve Flooding
Normal or High	High (10°F [-12°C] or more)	Less fill on the left side and top 2 rows of the evaporator	Low on Refrigerant/ Expansion Valve Starving
Normal	Low (5°F [-15°C] or less)	Less fill on the left side of the evaporator	Refrigerant Overcharge

## **FLOODING EXPANSION VALVE**

A flooding expansion valve will have discharge and suction line temperatures 20°F (-7°C) lower than normal freeze cycle temperatures. Normal suction line temperature and low discharge line temperature DO NOT verify a flooding valve. Both discharge line temperature and suction line temperature must be low to verify a flooding expansion valve. Ice fill pattern is thin on the left hand side of the evaporator.

## **STARVING EXPANSION VALVE/LOW REFRIGERANT CHARGE**

### **Important**

Confirm water float valve is set correctly. An overflowing standpipe mimics these symptoms exactly.

### **SYMPTOMS:**

- Ice Fill Pattern
  - Thin on top two rows of the evaporator
  - Thin on entire left side of the evaporator
  - Thick on the bottom of the evaporator
- Freeze time longer than normal

Diagnosis can be confirmed by adding 2 oz (56.7 g) of refrigerant: if the Suction line temperature drops or the ice fill pattern on the top two rows fills in, the ice machine is low on refrigerant. Refer to charging procedures for access valve installation procedure.

## **OVERCHARGED SYSTEM**

Suction line temperature will be slightly low during freeze cycle 5°F (-15°C). Discharge line temperature is normal. Actual amperage readings will be higher than nameplate rating.

## SM50

### DIAGNOSING AN ICE MACHINE THAT WILL NOT RUN



#### Warning

High (line) voltage is applied to the control board (terminals #20 and #21) at all times. Removing control board fuse or moving the toggle switch to OFF will not remove the power supplied to the control board.

1. Verify primary voltage is supplied to ice machine.
2. Verify that the fuse or circuit breaker is closed and the ice machine is plugged into a receptacle.
3. Verify control board fuse is OK.
4. Verify the transformer is supplying power to the control board.
  - If the interior light functions or the red control board light is energized the transformer is OK.
  - If the transformer is supplying power to the control board and the red control board light will not energize, replace the control board.
5. Verify the "Power" switch functions properly.
  - If the red control board light is energized and depressing the "Power" switch does not energize the green "Power" light, check the interconnecting wire, then replace the interface board.
6. Verify the bin thermostat functions properly.
  - The green "Power" light will be energized and the ice machine will function in the "Clean" cycle when the bin thermostat is open.
7. Check control board light to see if ice machine shutdown on over temperature limit (control board light will flash rapidly).
8. Replace the control board.
  - Be sure Steps 1-6 were followed thoroughly. Intermittent problems are not usually related to the control board.



## ICE MACHINE WILL NOT HARVEST

1. Verify cubes are present in evaporator and freeze time exceeds freeze chart cycle time.
  - Initial freeze cycle after resetting at toggle switch will be 5 minutes longer than chart time (refer to “Sequence of Operation” on page 86).
  - Verify control board is not set for additional freeze time to fill out the ice cubes, see “Cube Weight Adjustment” on page 97.
2. Observe control board light:
  - Steady light indicates thermistor operation is normal.
  - Slow flash indicates a thermistor problem (open or disconnected). Verify liquid line thermistor is connected to control board, securely attached to liquid line and insulated. Refer to Resistance chart and Ohm thermistor.
  - Rapid flash indicates liquid line temperature exceeded 170°F (76.7°C) (refer to “Discharge Pressure High Checklist” on page 150). If unable to determine cause, refer to Resistance chart and Ohm thermistor.
3. Reset ice machine.
  - Wait freeze cycle time plus an additional 5 minutes (refer to “Sequence of Operation” on page 86).
4. Verify the water inlet valve is energized during the entire harvest cycle and water flow is normal.
  - Although the hot gas valve is energized, the ice machine will not consistently harvest if the water inlet valve does not energize or has low water flow.
5. Check for power at the hot gas valve
  - Power is present – replace coil/valve.
  - No power at hot gas valve – check for power at circuit board connector, replace control board if no power is present.

**ICE QUALITY IS POOR — CUBES ARE SHALLOW, INCOMPLETE OR WHITE**

***Ice machine is dirty***

- Clean and sanitize the ice machine

***Water filtration is poor***

- Replace the filter

***Water softener is working improperly (if applicable)***

- Repair the water softener

***Poor incoming water quality***

- Contact a qualified company to test the quality of the incoming water and make appropriate filter recommendations

***Water escaping from sump during freeze cycle***

- Check standpipe and drain
- Check for water tracking out of water circuit

## **FREEZE CYCLE IS LONG, LOW ICE PRODUCTION**

### ***Water temperature is too high***

- Connect to a cold water supply, verify check valves in faucets and other equipment are functioning correctly

### ***Dirty Condenser***

- Clean condenser

### ***High air temperature entering condenser***

- Air temperature must not exceed 120°F (39°C)

### ***Water inlet valve filter screen is dirty***

- Remove the water inlet valve and clean the filter screen

### ***Water inlet valve stuck open or leaking***

- Turn off ice machine, if water continues to enter ice machine, verify water pressure is ok then replace water inlet valve

### ***Water inlet valve is not working***

- Water inlet valve must be replaced

### ***Refrigeration problem***

- Refer to refrigeration diagnostics

### ***Water escaping from sump during freeze cycle***

- Check standpipe and drain
- Check for water tracking out of water circuit

## **ICE MACHINE RUNS AND NO ICE IS PRODUCED**

### ***No water to ice machine***

- Correct water supply

### ***Incorrect incoming water pressure***

- Water pressure must be 20-80 psi (1.4-5.5 bar)

### ***Spray nozzle is blocked with mineral buildup***

- Clean and sanitize the ice machine

### ***Ambient temperature is too high or low***

- Ambient temperature must be between 50°F and 110°F (10°C and 43°C)

### ***Thermistor Disconnected or Open***

- Refer to thermistor diagnostics

## ANALYZING DISCHARGE PRESSURE

1. Determine the ice machine operating conditions:

Air temp. entering condenser \_\_\_\_\_

Air temp. around ice machine \_\_\_\_\_

Water temp. entering sump trough \_\_\_\_\_

2. Refer to "Cycle Times, 24 Hr. Ice Production and Refrigerant Pressure Charts" on page 203 for ice machine being checked.

Use the operating conditions determined in step 1 to find the published normal discharge pressures.

Freeze Cycle \_\_\_\_\_

Harvest Cycle \_\_\_\_\_

3. Perform an actual discharge pressure check.

	Freeze Cycle PSIG	Harvest Cycle PSIG
Beginning of Cycle	_____	_____
Middle of Cycle	_____	_____
End of Cycle	_____	_____

4. Compare the actual discharge pressure (step 3) with the published discharge pressure (step 2).

The discharge pressure is normal when the actual pressure falls within the published pressure range for the ice machine's operating conditions. It is normal for the discharge pressure to be higher at the beginning of the freeze cycle (when load is greatest), then drop throughout the freeze cycle.

## **DISCHARGE PRESSURE HIGH CHECKLIST**

### ***Improper Installation***

- Refer to “Installation and Visual Inspection Checklist” on page 104.

### ***Restricted Condenser Air Flow***

- High inlet air temperature
- Condenser discharge air re-circulation
- Dirty condenser fins
- Defective fan motor

### ***Improper Refrigerant Charge***

- Overcharged
- Non-condensable in system
- Wrong type of refrigerant

### ***Other***

- Non-Manitowoc components in system
- High side refrigerant lines/component restricted (before mid-condenser)

## **FREEZE CYCLE DISCHARGE PRESSURE LOW CHECKLIST**

### ***Improper Installation***

- Refer to “Installation and Visual Inspection Checklist” on page 104.

### ***Improper Refrigerant Charge***

- Undercharged
- Wrong type of refrigerant

### ***Other***

- Non-Manitowoc components in system
- High side refrigerant lines/component restricted (after condenser)
- Ambient temperature too low

NOTE: Do not limit your diagnosis to only the items listed in the checklists.

## **ANALYZING SUCTION PRESSURE**

The suction pressure gradually drops throughout the freeze cycle. The actual suction pressure (and drop rate) changes as the air and water temperature entering the ice machine changes. These variables also determine the freeze cycle times.

To analyze and identify the proper suction pressure drop throughout the freeze cycle, compare the published suction pressure to the published freeze cycle time.

**NOTE:** Analyze discharge pressure before analyzing suction pressure. High or low discharge pressure may be causing high or low suction pressure.

## Procedure

Step																				
<p>1. Determine the ice machine operating conditions.</p> <p><i>Example:</i> <i>Air temp. entering condenser: 90°F/32.2°C</i> <i>Air temp. around ice machine: 80°F/26.7°C</i> <i>Water temp. entering water fill valve: 70°F/21.1°C</i></p>																				
<p>2A. Refer to "Cycle Time" and "Operating Pressure" charts for ice machine model being checked. Using operating conditions from Step 1, determine published freeze cycle time and published freeze cycle suction pressure.</p> <p><i>Example:</i> <i>Published freeze cycle time: 19.1 - 21.7 minutes</i> <i>Published freeze cycle suction pressure: 20 - 3 psig</i></p>																				
<p>2B. Compare the published freeze cycle time and published freeze cycle suction pressure. Develop a chart.</p> <p><i>Example:</i></p> <table><tr><td colspan="5"><u>Published Freeze Cycle Time (minutes)</u></td></tr><tr><td>1</td><td>5</td><td>10</td><td>15</td><td>20</td></tr><tr><td> </td><td> </td><td> </td><td> </td><td> </td></tr><tr><td>20</td><td>16</td><td>12</td><td>8</td><td>3</td></tr></table> <p><u>Published Freeze Cycle Suction Pressure (psig)</u> <i>In the example, the proper suction pressure should be approximately 16 psig at 5 minutes; 12 psig at 10 minutes; etc.</i></p>	<u>Published Freeze Cycle Time (minutes)</u>					1	5	10	15	20						20	16	12	8	3
<u>Published Freeze Cycle Time (minutes)</u>																				
1	5	10	15	20																
20	16	12	8	3																
<p>3. Perform an actual suction pressure check at the beginning, middle and end of the freeze cycle. Note the times at which the readings are taken.</p> <p><i>Example:</i> <i>Manifold gauges were connected to the example ice machine and suction pressure readings taken as follows: _____ psig</i> <i>Beginning of Freeze cycle: 30 (at 1 min.)</i> <i>Middle of freeze cycle: 22 (at 10 min.)</i> <i>End of freeze cycle: 8 (at 20 min.)</i></p>																				
<p>4. Compare the actual freeze cycle suction pressure (step 3) to the published freeze cycle time and pressure comparison (step 2B). Determine if the suction pressure is high, low or acceptable.</p> <p><i>Example:</i> <i>In this example, the suction pressure is considered high throughout the freeze cycle. It should have been:</i> <i>Approximately 20 psig (at 1 minute) – not 30</i> <i>Approximately 12 psig (at 10 minutes) – not 22</i> <i>Approximately 3 psig (at 20 minutes) – not 8</i></p>																				



## **Suction Pressure High Checklist**

### ***Improper Installation***

- Refer to “Installation and Visual Inspection Checklist” on page 104.

### ***Discharge Pressure***

- Discharge pressure is too high, and is affecting suction pressure, refer to “Discharge Pressure High Checklist” on page 150.

### ***Improper Refrigerant Charge***

- Overcharged
- Wrong type of refrigerant
- Non-condensables in system

### ***Other***

- Non-Manitowoc components in system
- Hot gas valve leaking
- Defective compressor
- Water inlet valve leaking

## **Suction Pressure Low Checklist**

### ***Improper Installation***

- Refer to “Installation and Visual Inspection Checklist” on page 104.

### ***Discharge Pressure***

- Discharge pressure is too low, and is affecting suction pressure, refer to “Freeze Cycle Discharge Pressure Low Checklist” on page 150.

### ***Improper Refrigerant Charge***

- Undercharged
- Wrong type of refrigerant

## **Other**

- Non-Manitowoc components in system
- Improper water supply over evaporator refer to “Water System Checklist” on page 105.
- Loss of heat transfer from tubing on back side of evaporator
- Restricted/plugged liquid line drier
- Restricted/plugged tubing in suction side of refrigeration system

NOTE: Do not limit your diagnosis to only the items listed in the checklists.

## **HOT GAS VALVE**

### **General**

The hot gas valve is an electrically operated valve that opens when energized, and closes when de-energized.

### **Normal Operation**

The valve is de-energized (closed) during the freeze cycle and energized (open) during the harvest cycle. The valve is positioned between the receiver and the evaporator and performs two functions:

1. Prevents refrigerant from entering the evaporator during the freeze cycle.

The hot gas valve is not used during the freeze cycle. The hot gas valve is de-energized (closed) preventing refrigerant flow from the receiver into the evaporator.

2. Allows refrigerant vapor to enter the evaporator in the harvest cycle.

During the harvest cycle, the hot gas valve is energized (open) allowing refrigerant gas from the discharge line of the compressor to flow into the evaporator. The heat is absorbed by the evaporator and allows release of the ice slab.

Exact pressures vary according to ambient temperature. Harvest pressures can be found in the “Cycle Time/24 Hour Ice Production/Refrigerant Pressure Charts” in this book.

## Hot Gas Valve Analysis

The valve can fail in two positions:

- Valve will not open in the harvest cycle.
- Valve remains open during the freeze cycle.

### Valve Will Not Open in the Harvest Cycle

Although the circuit board has initiated a harvest cycle, the evaporator temperature remains unchanged from the freeze cycle.

### Valve Remains Open in the Freeze Cycle

Symptoms are dependent on the amount of leakage in the freeze cycle. A small amount of leakage will cause increased freeze cycle times. A large amount of leakage will result in no ice produced.

Use the following procedure and table to help determine if a hot gas valve is remaining partially open during the freeze cycle.

1. Wait five minutes into the freeze cycle.
2. Feel the inlet of the hot gas valve(s).

### Important

Feeling the hot gas valve outlet or across the hot gas valve itself will not work for this comparison. The hot gas valve outlet is on the suction side (cool refrigerant). It may be cool enough to touch even if the valve is leaking.

3. Feel the compressor discharge line.



### Warning

The inlet of the hot gas valve and the compressor discharge line could be hot enough to burn your hand. Just touch them momentarily.

4. Compare the temperature of the inlet of the hot gas valves to the temperature of the compressor discharge line.

<b>Findings</b>	<b>Comments</b>
<p>The inlet of the harvest valve is cool enough to touch and the compressor discharge line is hot.</p> <p style="text-align: center;"><b>Cool &amp; Hot</b></p>	<p>This is normal as the discharge line should always be too hot to touch and the harvest valve inlet, although too hot to touch during harvest, should be cool enough to touch after 5 minutes into the freeze cycle.</p>
<p>The inlet of the harvest valve is hot and approaches the temperature of a hot compressor discharge line.</p> <p style="text-align: center;"><b>Hot &amp; Hot</b></p>	<p>This is an indication something is wrong, as the harvest valve inlet did not cool down during the freeze cycle. If the compressor dome is also entirely hot, the problem is not a harvest valve leaking, but rather something causing the compressor (and the entire ice machine) to get hot.</p>
<p>Both the inlet of the harvest valve and the compressor discharge line are cool enough to touch.</p> <p style="text-align: center;"><b>Cool &amp; Cool</b></p>	<p>This is an indication something is wrong, causing the compressor discharge line to be cool to the touch. This is not caused by a harvest valve leaking.</p>

5. Record your findings on the table.

## Ice Production Check

The amount of ice a machine produces directly relates to the operating water and air temperatures. This means an ice machine with a 70°F (21.2°C) ambient temperature and 50°F (10.0°C) water produces more ice than the same ice machine with 90°F (32.2°C) ambient and 70°F (21.2°C) water.

1. Determine the ice machine operating conditions:  
Air temp entering condenser: \_\_\_\_°  
Air temp around ice machine: \_\_\_\_°  
Water temp entering sump trough: \_\_\_\_°
2. Refer to the appropriate 24-Hour Ice Production Chart. Use the operating conditions determined in Step 1 to find published 24 hr. ice production: \_\_\_\_  
Times are in minutes.  
Example: 1 min., 15 sec. converts to 1.25 min.  
(15 seconds ÷ 60 seconds = .25 minutes)  
Weights are in pounds.  
Example: 2 lb., 6 oz. converts to 2.375 lb.  
(6 oz. ÷ 16 oz. = .375 lb.)
3. Perform an ice production check using the formula below.

1. _____	+	_____	=	_____
Freeze Time		Harvest Time		Total Cycle Time
2. <u>1440</u>	÷	_____	=	_____
Mins in 24 hrs		Total Cycle Time		Cycles Per Day
3. _____	x	_____	=	_____
Weight of One Harvest		Cycles Per Day		Actual 24 Hr Production

4. Compare the results of Step 3 with Step 2. Ice production is normal when these numbers match closely. If they match closely, determine if:  
Another larger ice machine is required.  
Relocating the existing equipment to lower the load conditions is required.

## ADJUSTING CUBE WEIGHT

The cube weight can be increased from the factory setting by adjusting the finish time.

## ADDITIONAL FINISHING TIME CHECK

Press and hold the power button for 5 seconds.

- Count the flashes on the Automatic Ice Making light. The light will flash once for each additional minute of freeze cycle time.

## ADJUSTING FINISHING TIME

Adjust in 1-minute increments and allow the ice machine to run several freeze/harvest cycles, and then inspect the ice cubes. If a heavier cube weight is desired add another minute of freeze time and repeat the process.

Press and hold the power button.

- Press and release the clean button once for each additional minute of freeze cycle time desired.

Five minutes is the maximum additional freeze time that can be added. Pressing the clean button 6 times will reset the finishing time to zero additional minutes.

# Component Check Procedures

---

## Main Fuse

### FUNCTION

The control board fuse stops ice machine operation if electrical components fail causing high amp draw.

### SPECIFICATIONS

- QM20/QM30  
The main fuse is 250 Volt, 8 amp.
- QM45/SM50/Q130/Q170/Q210/Q270  
The main fuse is 250 Volt, 10 amp.



### Warning

High (line) voltage is applied to the control board at all times. Removing the control board fuse or moving the toggle switch to OFF will not remove the power supplied to the control board.

### CHECK PROCEDURE

1. If the bin switch light is on with the ice damper closed, the fuse is good.



### Warning

Disconnect electrical power to the entire ice machine before proceeding.

2. Remove the fuse. Check the resistance across the fuse with an ohmmeter.

Reading	Result
Open (OL)	Replace fuse
Closed (O)	Fuse is good

## Bin Switch

### QM45/Q130/Q170/Q210/Q270

#### Function

Bin switch operation is controlled by the movement of the ice damper. The bin switch has two main functions:

1. Terminating the harvest cycle and returning the ice machine to the freeze cycle.  
This occurs when the bin switch is opened and closed again within 7 seconds of opening during the harvest cycle.
2. Automatic ice machine shut-off.  
If the storage bin is full at the end of a harvest cycle, the sheet of cubes fails to clear the ice damper and holds it down. After the ice damper is held down for 7 seconds, the ice machine shuts off.

The ice machine remains off until enough ice is removed from the storage bin to allow the sheet of cubes to drop clear of the ice damper. As the ice damper swings back to the operating position, the bin switch closes and the ice machine restarts.

#### **Important**

The ice damper must be up (bin switch closed) to start ice making.

#### Check Procedure

1. Set the toggle switch to OFF.
2. Watch the bin switch light on the control board.
3. Move the ice damper upward, toward the evaporator. The bin switch must close. The bin switch light "on" indicates the bin switch has closed properly.
4. Move the ice damper away from the evaporator. The bin switch must open. The bin switch light "off" indicates the bin switch has opened properly.



## Ohm Test

1. Disconnect the bin switch wires to isolate the bin switch from the control board.
2. Connect an ohmmeter to the disconnected bin switch wires.
3. Cycle the bin switch open and closed numerous times by opening and closing the water curtain.

NOTE: To prevent misdiagnosis:

- Always use the water curtain magnet to cycle the switch (a larger or smaller magnet will affect switch operation).
- Watch for consistent readings when the bin switch is cycled open and closed (bin switch failure could be erratic).

## Bin Switch Removal — QM45/Q130

1. Disconnect power to the ice machine at service disconnect.
2. Disconnect bin switch wires in control box.
3. Depress tab on right side of evaporator with thumb.
4. Slide bin switch to right to remove.
5. Pull wiring into evaporator compartment.

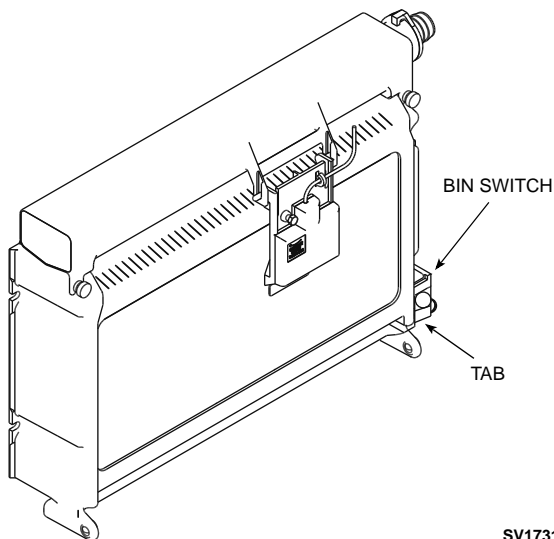

SV1731H

### Bin Switch Removal

## Bin Switch Removal — Q170/Q210/Q270

1. Disconnect power to the ice machine at service disconnect.
2. Disconnect bin switch wires in control box.
3. Insert a small screwdriver through the hole located in the top of the bin switch, and depress mounting tab slightly.
4. While depressing mounting tab roll bin switch to right to release.
5. Pull wiring into evaporator compartment.

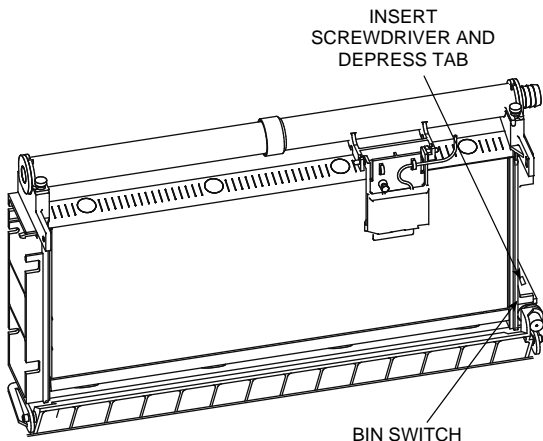

SV1695B

### Bin Switch Removal

# Bin Thermostat

## QM20/QM30

### Function

The bin thermostat stops the ice machine when the bin is full.

The level of ice in the ice storage bin controls the ice machine shut-off. When the bin is full, ice cubes contact the bin thermostat bulb holder, which cools down and opens the bin thermostat to stop the ice machine. The ice machine remains off until enough ice has been removed from the bin. This causes the thermostat bulb holder to warm and closes the bin thermostat, restarting the ice machine.

### Specifications

Control	Setting
Bin Thermostat	Cut in: 40°F (4.5°C) Cut out: 34°F (1.0°C)

### Check Procedure

#### **Warning**

High (line) voltage is applied to the control board (terminals #8 and #2) at all times. Removing the control board fuse or moving the toggle switch to OFF will not remove the power supplied to the control board.

#### **Warning**

Disconnect electrical power to the entire ice machine before proceeding.

1. Remove the back panel to access the bin thermostat.
2. Disconnect both wires #12 and #1 from the bin thermostat and check the resistance across the bin thermostat terminals.

No Ice on Bulb	Ice on Bulb	Result
Closed (O)	Open (OL)	Thermostat good
Open (OL)	Closed (O)	Replace thermostat

NOTE: After covering/uncovering the bulb holder with ice, wait at least three minutes to allow the thermostat to react. (Open/Close)

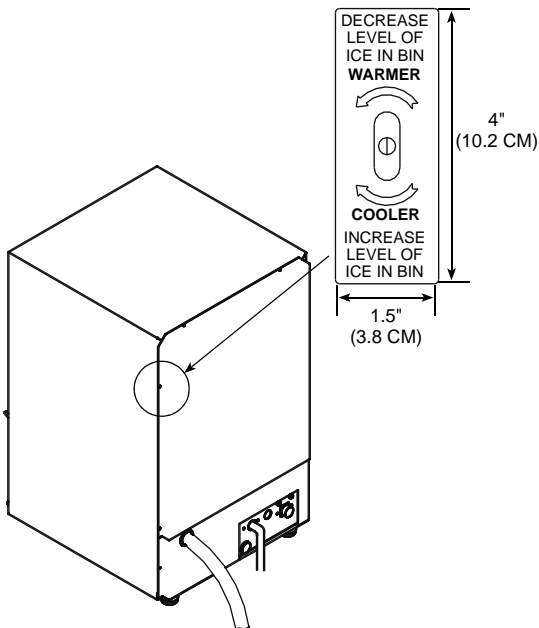

SV1680B

## SM50

### Function

The bin thermostat stops the ice machine when the bin is full. It is preset for normal ambient temperatures and adjustments are usually not required.

The level of ice in the ice storage bin controls the ice machine shut-off. When the bin is full, ice cubes contact the bin thermostat bulb holder, which cools down and opens the bin thermostat to stop the ice machine. The ice machine remains off until enough ice has been removed from the bin. This causes the thermostat bulb holder to warm and closes the bin thermostat, restarting the ice machine.

The thermostat is functioning correctly if, when three ice cubes are placed on the thermostat tube for 5 minutes, the ice machine stops. The ice machine should restart 5 minutes after the cubes are removed.

### Specifications

Control	Setting
Bin Thermostat	Cut in: 40°F (4.5°C) Cut out: 34°F (1.0°C)

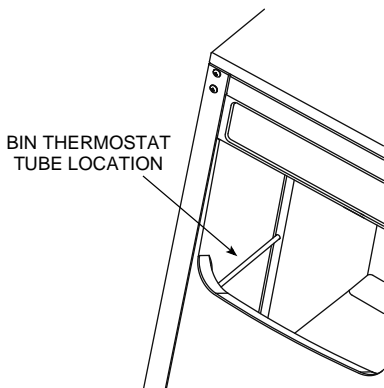

## Adjusting

If the ice machine stops before the bin is full or runs after the bin is full, ambient temperatures are probably high or low and the bin thermostat can be adjusted as follows:



### Warning

#### HAZARDOUS MOVING PARTS

Power is supplied to ice machine during this procedure. Avoid contact with the fan blade and the electrical connections.

1. To access the thermostat, remove the two screws attaching the front grill and remove the grill.
2. Remove the lower white plastic panel by pulling straight down.

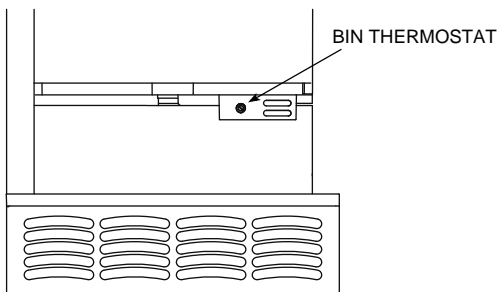

3. Turn the thermostat to the left to decrease the level of ice before automatic shut-off. Turn to the right to increase the level of ice before automatic shut-off.
4. Reassemble the plastic panel and grill.

## Check Procedure

### **Warning**

High (line) voltage is applied to the control board (terminals #20 and #21) at all times. Removing the control board fuse or depressing the power button will not remove the power supplied to the control board.

### **Warning**

Disconnect electrical power to the entire ice machine before proceeding.

1. Verify the capillary tube is inserted correctly in the bulb holder (17"/43 cm).
2. Remove the 2 bottom front panels to access the bin thermostat.
3. Disconnect wires #45 and #46 from the bin thermostat or control board and check the resistance across the bin thermostat terminals.

No Ice on Bulb	Ice on Bulb	Result
Closed (O)	Open (OL)	Thermostat good
Open (OL)	Closed (O)	Replace thermostat

NOTE: After covering/uncovering the bulb holder with ice, wait at least three minutes to allow the thermostat to react. (Open/Close)



# Liquid Line Thermistor

## QM20/QM30/SM50

### Function

The liquid line thermistor senses the refrigeration system liquid line temperature. This is used in conjunction with the control board to determine the length of the freeze and harvest cycles.

### Specifications

10,000 Ohms  $\pm$  2% at 25°C (77°F)



### Caution

Use only Manitowoc thermistors.

### Check Procedure

Thermistors generally fail because of moisture or physical damage. Manitowoc liquid line thermistors are encased in a specially designed, moisture-sealed aluminum block. This eliminates physical damage and moisture concerns.

Verify that the thermistor resistance is accurate and corresponds to the high and low temperature ranges.

1. Disconnect the thermistor at the control board. Connect the ohmmeter to the isolated thermistor wire leads.
2. Using a temperature meter capable of taking readings on curved copper lines, attach the temperature meter-sensing device to the liquid line next to the thermistor aluminum block.

### Important

Do not simply “insert” the sensing device under the insulation. It must be attached to and reading the actual temperature of the copper liquid line.

3. With the ice machine running, verify that the temperature of the discharge line (step 2) corresponds to the thermistor resistance reading (step 1) as stated in the temperature/resistant chart.

### Important

If the thermistor would fail closed, the light on the control board will flash rapidly.

If the thermistor would fail open, the light on the control board will flash slowly.

## Temperature/Resistance Chart

As the temperature rises at the thermistor block, the resistance drops.

### Important

If the ohmmeter reads "OL," check the scale setting on the meter before assuming the thermistor is bad.

Temperature of Thermistor		Resistance
°C	°F	K Ohms (x 1000)
15.6° - 21.1°	60° - 70°	15.31 - 11.88
21.1° - 26.7°	70° - 80°	11.88 - 9.29
26.7° - 32.2°	80° - 90°	9.29 - 7.33
32.2° - 37.8°	90° - 100°	7.33 - 5.82
37.8° - 43.3°	100° - 110°	5.82 - 4.66
43.3° - 48.9°	110° - 120°	4.66 - 3.75
48.9° - 54.4°	120° - 130°	3.75 - 3.05
54.4° - 60.0°	130° - 140°	3.05 - 2.49
60.0° - 65.6°	140° - 150°	2.49 - 2.04
65.6° - 71.1°	150° - 160°	2.04 - 1.68
71.1° - 76.7°	160° - 170°	1.68 - 1.40
76.7° - 82.2°	170° - 180°	1.40 - 1.17
82.2° - 87.8°	180° - 190°	1.17 - 0.98
87.8° - 93.3°	190° - 200°	0.98 - 0.82
93.3° - 98.9°	200° - 210°	0.82 - 0.70
100° (boiling water bath)	212°	0.73 - 0.62
104.4° - 110.0°	220° - 230°	0.59 - 0.51
110.0° - 115.6°	230° - 240°	0.51 - 0.43
115.6° - 121.1°	240° - 250°	0.43 - 0.37
121.1° - 126.7°	250° - 260°	0.37 - 0.33

## **Diagnosing Start Components**

If the compressor attempts to start, or hums and trips the overload protector, check the start components before replacing the compressor.

### **CAPACITOR**

Visual evidence of capacitor failure can include a bulged terminal end or a ruptured membrane. Do not assume a capacitor is good if no visual evidence is present. A good test is to install a known good substitute capacitor. Use a capacitor tester when checking a suspect capacitor. Clip the bleed resistor off the capacitor terminals before testing.

### **RELAY**

The relay has a set of contacts that connect and disconnect the start capacitor from the compressor start winding. The contacts on the relay are normally open. The relay senses the voltage generated by the start winding and closes and then opens the contacts as the compressor motor starts. The contacts remain open until the compressor is de-energized.

# **ON/OFF/WASH Toggle Switch**

## **FUNCTION**

The switch is used to place the ice machine in ON, OFF or WASH mode of operation.

## **SPECIFICATIONS**

Single-pole, double-throw switch. The switch is connected into a varying low D.C. voltage circuit.

## **CHECK PROCEDURE**

NOTE: Because of a wide variation in D.C. voltage, it is not recommended that a voltmeter be used to check toggle switch operation.

1. Inspect the toggle switch for correct wiring.
2. Isolate the toggle switch by disconnecting all wires from the switch, or by disconnecting the Molex connector from the control board.
3. Check across the toggle switch terminals using a calibrated ohmmeter. Note where the wire numbers are connected to the switch terminals, or refer to the wiring diagram to take proper readings.

## QM45/Q130/Q170/Q210/Q270

Switch Setting	Terminals	Ohm Reading
ON	24-21	Open
	24-20	Closed
	20-21	Open
WASH	24-20	Open
	24-21	Closed
	20-21	Open
OFF	24-20	Open
	24-21	Open
	20-21	Open

Replace the toggle switch if ohm readings do not match all three-switch settings.

## QM20/QM30

Switch Setting	Terminals	Ohm Reading
ON	7-4	Open
	7-12	Closed
	12-4	Open
WASH	7-12	Open
	7-4	Closed
	12-4	Open
OFF	7-12	Open
	7-4	Open
	12-4	Open

Replace the toggle switch if ohm readings do not match all three-switch settings.

## **Ice Thickness Probe**

**QM45/Q130/Q170/Q210/Q270**

### **How The Probe Works**

Manitowoc's electronic sensing circuit does not rely on refrigerant pressure, evaporator temperature, water levels or timers to produce consistent ice formation.

As ice forms on the evaporator, water (not ice) contacts the ice thickness probe. After the water completes this circuit across the probe continuously for 6-10 seconds, a harvest cycle is initiated.

### **Freeze Time Lock-In Feature**

The ice machine control system incorporates a freeze time lock-in feature. This prevents the ice machine from short cycling in and out of harvest.

The control board locks the ice machine in the freeze cycle for six minutes. If water contacts the ice thickness probe during these six minutes, the harvest light will come on (to indicate that water is in contact with the probe), but the ice machine will stay in the freeze cycle. After the six minutes are up, a harvest cycle is initiated. This is important to remember when performing diagnostic procedures on the ice thickness control circuitry.

To allow the service technician to initiate a harvest cycle without delay, this feature is not used on the first cycle after moving the toggle switch OFF and back to ON.

### **Maximum Freeze Time**

The control system includes a built-in safety, which will automatically cycle the ice machine into harvest after 60 minutes in the freeze cycle.

## ICE THICKNESS CHECK

The ice thickness probe is factory-set to maintain the ice bridge thickness at 1/8" (3.2 mm).

**NOTE:** Make sure the water curtain is in place when performing this check. It prevents water from splashing out of the water trough.

1. Inspect the bridge connecting the cubes. It should be about 1/8" (3.2 mm) thick.
2. If adjustment is necessary, turn the ice thickness probe adjustment screw clockwise to increase bridge thickness, or counterclockwise to decrease bridge thickness.

**NOTE:** Turning the adjustment 1/3 of a turn will change the ice thickness about 1/16" (1.5 mm).

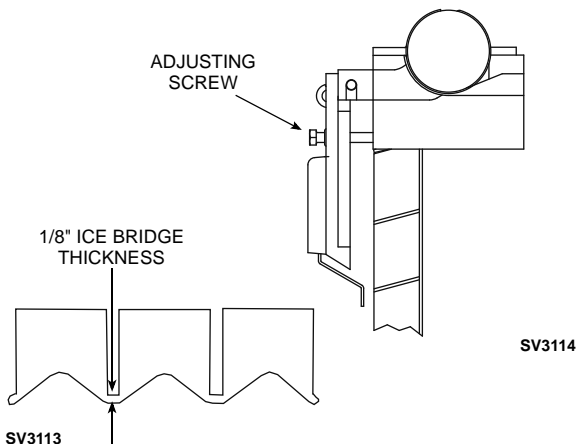

### Ice Thickness Check

Make sure the ice thickness probe wire and the bracket do not restrict movement of the probe.

## **Compressor Electrical Diagnostics**

The compressor does not start or will trip repeatedly on overload.

### **CHECK RESISTANCE (OHM) VALUES**

NOTE: Compressor windings can have very low ohm values. Use a properly calibrated meter.

Perform the resistance test after the compressor cools. The compressor dome should be cool enough to touch (below 120°F/49°C) to ensure that the overload is closed and the resistance readings will be accurate.

### **SINGLE PHASE COMPRESSORS**

1. Disconnect power from the condensing unit and remove the wires from the compressor terminals.
2. The resistance values between C and S and between C and R, when added together should equal the resistance value between S and R.
3. If the overload is open, there will be a resistance reading between S and R, and open readings between C and S and between C and R. Allow the compressor to cool, then check the readings again.

### **CHECK MOTOR WINDINGS TO GROUND**

Check continuity between all three terminals and the compressor shell or copper refrigeration line. Scrape metal surface to get good contact. If continuity is present, the compressor windings are grounded and the compressor should be replaced.

To determine if the compressor is seized check the amp draw while the compressor is trying to start.



## **COMPRESSOR DRAWING LOCKED ROTOR**

The two likely causes of this are:

- Defective starting component
- Mechanically seized compressor

To determine which you have:

1. Install high and low side gauges.
2. Try to start the compressor.
3. Watch the pressures closely.
  - If the pressures do not move, the compressor is seized. Replace the compressor.
  - If the pressures move, the compressor is turning slowly and is not seized. Check the capacitors and relay.

## **COMPRESSOR DRAWING HIGH AMPS**

The continuous amperage draw on start-up should not be near the maximum fuse size indicated on the serial tag.

The wiring must be correctly sized to minimize voltage drop at compressor start-up. The voltage when the compressor is trying to start must be within  $\pm 10\%$  of the nameplate voltage.

# Fan Cycle Control

## QM45/Q130/Q170/Q210/Q270

### Function

Cycles the fan motor on and off to maintain proper operating discharge pressure.

The fan cycle control closes on an increase, and opens on a decrease in discharge pressure.

### Specifications

Model	Cut-In (Close)	Cut-Out (Open)
QM45	145 psig $\pm$ 5	110 psig $\pm$ 5
Q130	250 psig $\pm$ 5	200 psig $\pm$ 5
Q170	275 psig $\pm$ 5	225 psig $\pm$ 5
Q210	275 psig $\pm$ 5	225 psig $\pm$ 5
Q270	250 psig $\pm$ 5	200 psig $\pm$ 5

### Check Procedure

Disconnect electrical power to the ice machine at the electrical service disconnect.

Verify fan motor windings are not open or grounded, and fan spins freely.

Connect manifold gauges to ice machine.

Hook voltmeter in parallel across the fan cycle control, leaving wires attached.

Reconnect electrical power to the ice machine and set the ON/OFF/WASH toggle switch to ON.

Wait until water flows over the evaporator then refer to chart below.

System Pressure:	Reading Should Be:	Fan Should Be:
above cut-in	0 volts	running
below cut-out	line voltage	off

## High Pressure Cutout (HPCO) Control

QM45/Q130/Q170/Q210/Q270

### Function

Stops the ice machine if subjected to excessive high-side pressure.

The HPCO control is normally closed, and opens on a rise in discharge pressure.

### Specifications

Cut-out: 450 psig  $\pm$ 10

Cut-in: Automatic reset

(Must be below 300 psig to reset).

### Check Procedure

1. Set ON/OFF/WASH switch to OFF.
2. Connect manifold gauges.
3. Hook voltmeter in parallel across the HPCO, leaving wires attached.
4. On water-cooled models, close the water service valve to the water condenser inlet. On self-contained air-cooled models, disconnect the fan motor.
5. Set ON/OFF/WASH switch to ON.
6. No water or air flowing through the condenser will cause the HPCO control to open because of excessive pressure. Watch the pressure gauge and record the cut-out pressure.



### Warning

If discharge pressure exceeds 460 psig and the HPCO control does not cut out, set ON/OFF/WASH switch to OFF to stop ice machine operation.

Replace the HPCO control if it:

- Will not reset (below 300 psig)
- Does not open at the specified cut-out point

## Filter-Driers

### LIQUID LINE FILTER DRIER

The filter-drier used on Manitowoc ice machines are manufactured to Manitowoc specifications.

The difference between a Manitowoc drier and an off-the-shelf drier is in filtration. A Manitowoc drier has dirt-retaining filtration, with fiberglass filters on both the inlet and outlet ends. This is very important because ice machines have a back-flushing action that takes place during every harvest cycle.

A Manitowoc filter-drier has a very high moisture removal capability and a good acid removal capacity.

#### **Important**

The liquid line drier is covered as a warranty part. The liquid line drier must be replaced any time the system is opened for repair.

# Refrigerant Recovery/Evacuation

## DEFINITIONS

### Recover

To remove refrigerant, in any condition, from a system and store it in an external container, without necessarily testing or processing it in any way.

### Recycle

To clean refrigerant for re-use by oil separation and single or multiple passes through devices, such as replaceable core filter-driers, which reduce moisture, acidity and particulate matter. This term usually applies to procedures implemented at the field job site or at a local service shop.

### Reclaim

To reprocess refrigerant to new product specifications (see below) by means which may include distillation. A chemical analysis of the refrigerant is required after processing to be sure that product specifications are met. This term usually implies the use of processes and procedures available only at a reprocessing or manufacturing facility.

Chemical analysis is the key requirement in this definition. Regardless of the purity levels reached by a reprocessing method, refrigerant is not considered "reclaimed" unless it has been chemically analyzed and meets ARI Standard 700 (latest edition).

### New Product Specifications

This means ARI Standard 700 (latest edition). Chemical analysis is required to assure that this standard is met.

## REFRIGERANT RE-USE POLICY

Manitowoc recognizes and supports the need for proper handling, re-use, and disposal of CFC and HCFC refrigerants. Manitowoc service procedures require recapturing refrigerants, not venting them to the atmosphere.

It is not necessary, in or out of warranty, to reduce or compromise the quality and reliability of your customers' products to achieve this.

### **Important**

Manitowoc Ice assumes no responsibility for use of contaminated refrigerant. Damage resulting from the use of contaminated, recovered, or recycled refrigerant is the sole responsibility of the servicing company.

Manitowoc approves the use of:

1. New Refrigerant

- Must be of original nameplate type.

2. Reclaimed Refrigerant

- Must be of original nameplate type.
- Must meet ARI Standard 700 (latest edition) specifications.

3. Recovered or Recycled Refrigerant

- Must be recovered or recycled in accordance with current local, state and federal laws.
- Must be recovered from and re-used in the same Manitowoc product. Re-use of recovered or recycled refrigerant from other products is not approved.
- Recycling equipment must be certified to ARI Standard 740 (latest edition) and be maintained to consistently meet this standard.

4. Recovered refrigerant must come from a “contaminant-free” system. To decide whether the system is contaminant free, consider:
  - Type(s) of previous failure(s)
  - Whether the system was cleaned, evacuated and recharged properly following failure(s)
  - Whether the system has been contaminated by this failure
  - Compressor motor burnouts and improper past service prevent refrigerant re-use.
  - Refer to “System Contamination Cleanup” on page 190 to test for contamination.
5. “Substitute” or “Alternative” Refrigerant
  - Must use only Manitowoc-approved alternative refrigerants.
  - Must follow Manitowoc-published conversion procedures.

## RECOVERY AND RECHARGING PROCEDURES

### Q130/Q170/Q210/Q270

Do not purge refrigerant to the atmosphere. Capture refrigerant using recovery equipment. Follow the manufacturer's recommendations.

#### **Important**

Manitowoc Ice assumes no responsibility for the use of contaminated refrigerant. Damage resulting from the use of contaminated refrigerant is the sole responsibility of the servicing company.

#### **Important**

Replace the liquid line drier before evacuating and recharging. Use only a Manitowoc (O.E.M.) liquid line filter drier to prevent voiding the warranty.

## CONNECTIONS

1. Suction side of the compressor through the suction service valve.
2. Discharge side of the compressor through the discharge service valve.



## SELF-CONTAINED RECOVERY/EVACUATION

1. Place the toggle switch in the OFF position.
2. Install manifold gauges, charging cylinder/scale, and recovery unit or two-stage vacuum pump.
3. Open (backseat) the high and low side ice machine service valves, and open high and low side on manifold gauges.
4. Perform recovery or evacuation:
  - A. Recovery: Operate the recovery unit as directed by the manufacturer's instructions.
  - B. Evacuation prior to recharging: Pull the system down to 500 microns. Then, allow the pump to run for an additional half hour. Turn off the pump and perform a standing vacuum leak check.

NOTE: Check for leaks using a halide or electronic leak detector after charging the ice machine.

Follow the Charging Procedures below.

## CHARGING PROCEDURES

### **Important**

The charge is critical on all Manitowoc ice machines. Use a scale or a charging cylinder to ensure the proper charge is installed.

1. Be sure the toggle switch is in the OFF position.
2. Close the vacuum pump valve, the low side service valve, and the low side manifold gauge valve.
3. Open the high side manifold gauge valve, and backseat the high side service valve.
4. Open the charging cylinder and add the proper refrigerant charge (shown on nameplate) through the discharge service valve.
5. Let the system "settle" for 2 to 3 minutes.
6. Place the toggle switch in the ICE position.
7. Close the high side on the manifold gauge set. Add any remaining vapor charge through the suction service valve (if necessary).

**NOTE:** Manifold gauges must be removed properly to ensure that no refrigerant contamination or loss occurs.

8. Make sure that all of the vapor in the charging hoses is drawn into the ice machine before disconnecting the charging hoses.
  - A. Run the ice machine in freeze cycle.
  - B. Close the high side service valve at the ice machine.
  - C. Open the low side service valve at the ice machine (when supplied) or disconnect the low loss fitting from the access valve.
  - D. Open the high and low side valves on the manifold gauge set. Any refrigerant in the lines will be pulled into the low side of the system.
  - E. Allow the pressures to equalize while the ice machine is in the freeze cycle.
  - F. Close the low side service valve at the ice machine.
9. Remove the hoses from the ice machine and install the caps.

## QM20/QM30/QM45

Do not purge refrigerant to the atmosphere. Capture refrigerant using recovery equipment. Follow the manufacturer's recommendations.

### **Important**

Manitowoc Ice assumes no responsibility for the use of contaminated refrigerant. Damage resulting from the use of contaminated refrigerant is the sole responsibility of the servicing company.

### **Important**

Replace the liquid line drier before evacuating and recharging. Use only a Manitowoc (O.E.M.) liquid line filter drier to prevent voiding the warranty.

## CONNECTIONS

The QM series ice machines are critically charged. There are no refrigerant access ports on QM series ice machines.

1. Locate the high and low side process tubes.
2. Install a piercing valve (saddle valve) on both the high and low side process tubes.

### **Important**

Remove piercing valves after charging. Unit is critically charged.

### **Important**

Purge system with nitrogen while brazing to prevent build up of copper oxide in the refrigeration system.

## **Important**

Manifold gauges must be removed properly to ensure that no refrigerant contamination or loss occurs. A quick disconnect is required for the high side connection unless high side valve has shut off.

### **RECOVERY/EVACUATION**

1. Place the toggle switch in the OFF position.
2. Install manifold gauges, charging scale, and recovery unit or two-stage vacuum pump.
3. Open the high and low side valves on manifold gauges.
4. Perform recovery or evacuation:
  - A. Recovery: Operate the recovery unit as directed by the manufacturer's instructions.
  - B. Evacuation prior to recharging: Pull the system down to 500 microns. Then, allow the pump to run for an additional half hour. Turn off the pump and perform a standing vacuum leak check.

**NOTE:** Check for leaks using a halide or electronic leak detector after charging the ice machine.

## CHARGING PROCEDURES

### **Important**

The charge is critical on all Manitowoc ice machines. Use a scale to ensure the proper charge is installed. A quick disconnect is required for the high side connection.

1. Be sure the toggle switch is in the OFF position.
2. Close the vacuum pump valve and the low side manifold gauge valve.
3. Open the high side manifold gauge valve.
4. Open the refrigerant cylinder and add the proper refrigerant charge (shown on nameplate) through the discharge service valve.
5. Close the high side on the manifold gauge set. Add any remaining vapor charge through the suction access fitting (if necessary).
6. Let the system "settle" for 2 to 3 minutes.
7. Place the toggle switch in the ICE position.

NOTE: Manifold gauges must be removed properly to ensure that no refrigerant contamination or loss occurs.

8. Make sure that all of the vapor in the charging hoses is drawn into the ice machine before disconnecting the charging hoses.
  - A. Run the ice machine in the freeze cycle.
  - B. Verify the refrigerant cylinder valve is closed.
  - C. Open the high and low side valves on the manifold gauge set. Any refrigerant in the lines will be pulled into the low side of the system.
  - D. Allow the pressures to equalize while the ice machine is in the freeze cycle.
  - E. Close the high and low side manifold gauge set.
  - F. Remove the hoses from the ice machine and install the caps.

# System Contamination Cleanup

## GENERAL

This section describes the basic requirements for restoring contaminated systems to reliable service.

### Important

Manitowoc Ice assumes no responsibility for the use of contaminated refrigerant. Damage resulting from the use of contaminated refrigerant is the sole responsibility of the servicing company.

## DETERMINING SEVERITY OF CONTAMINATION

System contamination is generally caused by either moisture or residue from compressor burnout entering the refrigeration system.

Inspection of the refrigerant usually provides the first indication of system contamination. Obvious moisture or an acrid odor in the refrigerant indicates contamination.

If either condition is found, or if contamination is suspected, use a Total Test Kit from Totaline or a similar diagnostic tool. These devices sample refrigerant, eliminating the need to take an oil sample. Follow the manufacturer's directions.

If a refrigerant test kit indicates harmful levels of contamination, or if a test kit is not available, inspect the compressor oil.

1. Remove the refrigerant charge from the ice machine.
2. Remove the compressor from the system.
3. Check the odor and appearance of the oil.
4. Inspect open suction and discharge lines at the compressor for burnout deposits.
5. If no signs of contamination are present, perform an acid oil test to determine the type of cleanup required.

<b>Contamination/Cleanup Chart</b>	
<b>Symptoms/Findings</b>	<b>Required Cleanup Procedure</b>
No symptoms or suspicion of contamination	Normal evacuation/recharging procedure
Moisture/Air Contamination symptoms Refrigeration system open to atmosphere for longer than 15 minutes Refrigeration test kit and/or acid oil test shows contamination No burnout deposits in open compressor lines	Mild contamination cleanup procedure
Mild Compressor Burnout symptoms Oil appears clean but smells acrid Refrigeration test kit or acid oil test shows harmful acid content No burnout deposits in open compressor lines	Mild contamination cleanup procedure
Severe Compressor Burnout symptoms Oil is discolored, acidic, and smells acrid Burnout deposits found in the compressor, lines, and other components	Severe contamination cleanup procedure

## MILD SYSTEM CONTAMINATION CLEANUP PROCEDURE

1. Replace any failed components.
2. If the compressor is good, change the oil.
3. Replace the liquid line drier.

NOTE: If the contamination is from moisture, use heat lamps during evacuation. Position them at the compressor, condenser and evaporator prior to evacuation. Do not position heat lamps too close to plastic components, or they may melt or warp.

### Important

Dry nitrogen is recommended for this procedure. This will prevent CFC release.

4. Follow the normal evacuation procedure, except replace the evacuation step with the following:
  - A. Pull vacuum to 1000 microns. Break the vacuum with dry nitrogen and sweep the system. Pressurize to a minimum of 5 psig.
  - B. Pull vacuum to 500 microns. Break the vacuum with dry nitrogen and sweep the system. Pressurize to a minimum of 5 psig.
  - C. Change the vacuum pump oil.
  - D. Pull vacuum to 500 microns. Run the vacuum pump for 1/2 hour on self-contained models, 1 hour on remotes.

NOTE: You may perform a pressure test as a preliminary leak check. You should use an electronic leak detector after system charging to be sure there are no leaks.

5. Charge the system with the proper refrigerant to the nameplate charge.
6. Operate the ice machine.



## SEVERE SYSTEM CONTAMINATION CLEANUP PROCEDURE

1. Remove the refrigerant charge.
2. Remove the compressor.
3. Disassemble the hot gas solenoid valve. If burnout deposits are found inside the valve, install a rebuild kit, and replace the TXV and head pressure control valve.
4. Wipe away any burnout deposits from suction and discharge lines at compressor.
5. Sweep through the open system with dry nitrogen.

### Important

Refrigerant sweeps are not recommended, as they release CFCs into the atmosphere. Dry nitrogen is recommended for this procedure. This will prevent CFC release.

6. Install a new compressor and new start components.
7. Install suction line filter-drier in front of compressor.
8. Install a new liquid line drier.
9. Follow the normal evacuation procedure, except replace the evacuation step with the following:
  - A. Pull vacuum to 1000 microns. Break the vacuum with dry nitrogen and sweep the system. Pressurize to a minimum of 5 psig.
  - B. Change the vacuum pump oil.
  - C. Pull vacuum to 500 microns. Break the vacuum with dry nitrogen and sweep the system. Pressurize to a minimum of 5 psig.
  - D. Change the vacuum pump oil.
  - E. Pull vacuum to 500 microns. Run the vacuum pump for 1 additional hour.
10. Charge the system with the proper refrigerant to the nameplate charge.
11. Operate the ice machine for one hour. Then, check the pressure drop across the suction line filter-drier.
  - A. If the pressure drop is less than 2 psig, the filter-drier should be adequate for complete cleanup.
  - B. If the pressure drop exceeds 2 psig, change the suction line filter-drier and the liquid line drier. Repeat until the pressure drop is acceptable.
12. Operate the ice machine for 48 – 72 hours. Replace the suction line and liquid line drier if necessary.
13. Follow normal evacuation procedures.

## REPLACING PRESSURE CONTROLS WITHOUT REMOVING REFRIGERANT CHARGE

This procedure reduces repair time and cost. Use it when any of the following components require replacement, and the refrigeration system is operational and leak-free.

- Fan cycle control
- High pressure cut-out control
- High side access valve
- Low side access valve

### Important

This is a required in-warranty repair procedure.

1. Disconnect power to the ice machine.
2. Follow all manufacturers' instructions supplied with the pinch-off tool. Position the pinch-off tool around the tubing as far from the pressure control as feasible. (See the figure on next page.) Clamp down on the tubing until the pinch-off is complete.



### Warning

Do not unsolder a defective component. Cut it out of the system. Do not remove the pinch-off tool until the new component is securely in place.

3. Cut the tubing of the defective component with a small tubing cutter.
4. Solder the replacement component in place. Allow the solder joint to cool.
5. Remove the pinch-off tool.
6. Re-round the tubing. Position the flattened tubing in the proper hole in the pinch off tool. Tighten the wing nuts until the block is tight and the tubing is rounded.

**NOTE:** The pressure controls will operate normally once the tubing is re-rounded. Tubing may not re-round 100%.

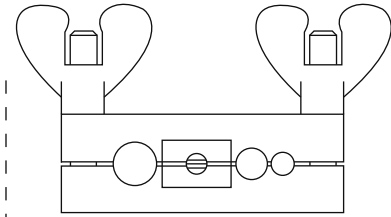

FIG. A - "PINCHING OFF" TUBING

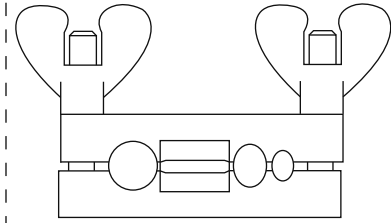

FIG. B - RE-ROUNDING TUBING

SV1406

### Using Pinch Off Tool

## Q270 Condenser Fan Motor Replacement

Access to remove, clean or replace the condenser fan/motor can be obtained by performing the following:

1. Disconnect electrical power to the ice machine at the electrical service disconnect.
2. Remove the screws that secure the condenser to the cabinet and the base to the cabinet.
3. Slide the base forward until contact is made with the stop screw (approximately 2.5" [6.3 cm]).

### **Caution**

Do not move base past the stop screw, tubing damage could result.

4. Remove right hand screw securing condenser to base.
5. Pivot condenser forward to obtain 5" (12.7 cm) between the cabinet and condenser shroud. Take care not to kink refrigeration tubing.

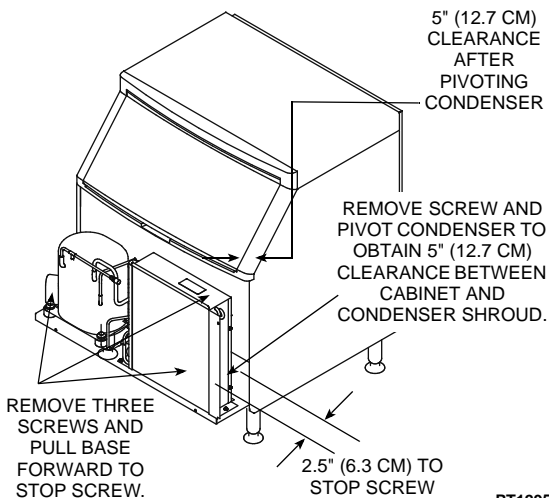

PT1295A

### Accessing the Condenser Fan Motor

## Brazing Procedures for Danfoss Solenoid Valves

- Danfoss stainless steel solenoid valves require a slightly different brazing technique than brass-bodied valves.  
Copper clad stainless steel does not require as much flame contact as copper tubing.  
Apply heat to the copper tubing first then the solenoid socket.
- 15% silver solder is recommended although silver bearing solder in the 5% to 55% range can be used.

1. Remove coil and verify direction of flow.

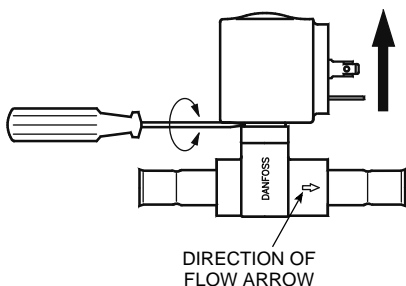

SV3069

2. Fit valve in place and align stem at the 12:00 position.

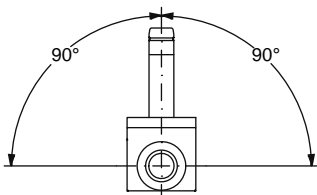

SV3070

3. **Do not disassemble valve.**

MAX. 1300°F  
(700°C)

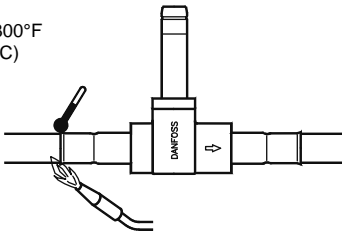

SV3071

4. Apply heat to copper tubing first and move flame toward valve socket.
  - A. Heat copper tubing for approximately 10 to 15 seconds then direct the heat to the solenoid socket.
  - B. Heat the solenoid socket for 2 to 5 seconds and apply silver solder to joint.
  - C. Do not attempt to fill solenoid flange with solder. Solder will draw into socket.
5. Install new liquid line drier.
6. Leak check joints by pressurizing system with 150 psig nitrogen.
7. Evacuate and re-charge system to nameplate charge.
8. Reinstall coil (using a twisting motion) and attach wiring.

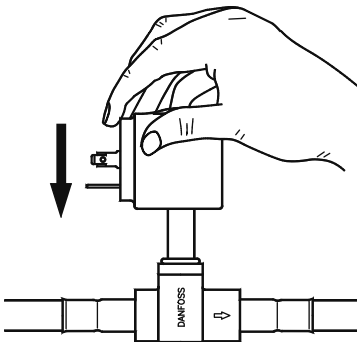

SV3073

# Component Specifications

## Main Fuse

	Volt	Amp
QM20/QM30	250	8
QM45/SM50/ Q130/Q170/Q210/Q270	250	10

## Bin Switch

### QM45/Q130/Q170/Q210/Q270

Bin switch operation is controlled by the movement of the ice damper.

## Bin Thermostat

### QM20/QM30/SM50

Control	Setting
Bin Thermostat	Cut in: 40°F (4.5°C) Cut out: 34°F (1.0°C)

## ON/OFF/WASH Toggle Switch

Single-pole, double-throw switch. The switch is connected into a varying low D.C. voltage circuit.

## Fan Control Cycle

### QM45/Q130/Q170/Q210/Q270

Model	Cut-in (Close)	Cut-out (Open)
QM45	145 psig $\pm$ 5	110 psig $\pm$ 5
Q130	250 psig $\pm$ 5	200 psig $\pm$ 5
Q170	275 psig $\pm$ 5	225 psig $\pm$ 5
Q210	275 psig $\pm$ 5	225 psig $\pm$ 5
Q270	250 psig $\pm$ 5	200 psig $\pm$ 5

## High Pressure Cutout (HPCO) Control

Cut-out	Cut-in
450 psig $\pm$ 10 (3103 kPa $\pm$ 69) 31 bar $\pm$ .69	Automatic Reset
Must be below 300 psig (2068 kPa, 20.68 bar) to reset.	

## Filter-Driers

Drier with dirt-retaining filtration.

## Liquid Line Thermistor

### QM20/QM30/SM50

10,000 Ohms  $\pm$  2% at 25°C (77°F)



### Caution

Use only Manitowoc thermistors.



## Total System Refrigerant Charge

### Important

This information is for reference only. Refer to the ice machine serial number tag to verify the system charge. Serial plate information overrides information listed on this page.

Model	Air-Cooled	Water-Cooled	Refrigerant Type
QM20	4.6 oz (130 g)	NA	R134A
QM30	5.8 oz (165 g)	NA	R134A
QM45	8 oz (227 g)	NA	R134A
Q130 Tecumseh Compressor	11 oz (312 g)	11 oz (312 g)	R404A
Q130 Danfoss Compressor Before Serial Number 310047287	8 oz (227 g)	11 oz (312 g)	R404A
Q130 Danfoss Compressor After Serial Number 310047287	10 oz (290 g)	12 oz (340 g)	R404A
Q170	14 oz (397 g)	NA	R404A
Q210	15 oz (425 g)	11 oz (312 g)	R404A
Q270 Tecumseh Compressor	17 oz (482 g)	16 oz (454 g)	R404A
Q270 Danfoss Compressor	22 oz (624 g)	16 oz (454 g)	R404A
SM50	5.6 oz	NA	R134A

**This Page Intentionally Left Blank**

## Charts

---

### **Cycle Times, 24 Hr. Ice Production and Refrigerant Pressure Charts**

These charts are used as guidelines to verify correct ice machine operation.

Accurate collection of data is essential to obtain the correct diagnosis.

- Refer to “Operational Analysis Chart” for the list of data that must be collected for refrigeration diagnostics. This list includes: before beginning service, ice production check, installation/visual inspection, water system checklist, ice formation pattern, safety limits, comparing evaporator inlet/outlet temperatures, hot gas valve analysis, discharge and suction pressure analysis.
- Ice production checks that are within 10% of the chart are considered normal. This is due to variances in water and air temperature. Actual temperatures will seldom match the chart exactly.
- Zero out manifold gauge set before obtaining pressure readings to avoid misdiagnosis.
- Discharge and suction pressure are highest at the beginning of the cycle. Suction pressure will drop throughout the cycle. Verify the pressures are within the range indicated.

## QM20 SELF-CONTAINED AIR-COOLED

NOTE: These characteristics may vary depending on operating conditions.

NOTE: The first cycle, at any temperature, will take up to three minutes longer.

### Cycle Times

Freeze Time + Harvest Time = Total Cycle Time

Air Temp. Entering Condenser °F/°C	Freeze Time			Harvest Time
	Water Temperature °F/°C			
	50/10	68/20	86/30	
68/20	15-18	16-19	16-19	1.5-3.5
77/25	16-19	18-21	18-21	
86/30	20-23	21-24	21-24	
95/35	24-27	26-29	26-29	

Times in minutes

### 24-Hour Ice Production

Air Temp. Entering Condenser °F/°C	Water Temperature °F/°C					
	50/10		68/20		86/30	
	lb	kg	lb	kg	lb	kg
68/20	46	21	42	19	37	17
77/25	44	20	40	18	35	16
86/30	40	18	37	17	33	15
95/35	35	16	33	15	29	13

Based on average ice slab weight of 0.46 – 0.60 lb (200 – 275 g)

## QM30 SELF-CONTAINED AIR-COOLED

NOTE: These characteristics may vary depending on operating conditions.

NOTE: The first cycle, at any temperature, will take up to three minutes longer.

### Cycle Times

Freeze Time + Harvest Time = Total Cycle Time

Air Temp. Entering Condenser °F/°C	Freeze Time			Harvest Time
	Water Temperature °F/°C			
	50/10	95/35	104/40	
70/21	9.1-12.9	9.4-13.4	10.2-14.5	1.25- 3.25
80/27	10.0-14.2	10.5-14.8	11.4-16.1	
90/32	10.9-15.4	11.4-16.1	12.6-17.7	
100/38	12.3-17.3	12.9-18.1	14.3-20.1	

Times in minutes

### 24-Hour Ice Production

Air Temp. Entering Condenser °F/°C	Water Temperature °F/°C		
	50/10	70/21	90/32
70/21	60	58	54
80/27	55	53	49
90/32	51	49	45
100/38	46	44	40

Based on ice slab weight of .44 – .60 lb (200 – 275 g)

## QM45 SELF-CONTAINED AIR-COOLED

NOTE: These characteristics may vary depending on operating conditions.

NOTE: The first cycle, at any temperature, will take up to three minutes longer.

### Cycle Times

Freeze Time + Harvest Time = Total Cycle Time

Air Temp. Entering Condenser °F/°C	Freeze Time			Harvest Time
	Water Temperature °F/°C			
	50/10	70/21	90/32	
70/21	14.6-16.5	17.6-19.9	20.3-23.0	1.0-2.5
80/27	15.5-17.5	18.9-21.3	22.0-24.9	
90/32	17.6-19.9	22.0-24.9	26.3-29.7	
100/38	20.3-23.0	23.9-27.1	29.0-32.8	

Times in minutes

### 24-Hour Ice Production

Air Temp. Entering Condenser °F/°C	Water Temperature °F/°C		
	50/10	70/21	90/32
	lb/kg	lb/kg	lb/kg
70/21	95/43	80/36	70/32
80/27	90/41	75/34	65/29
90/32	80/36	65/30	55/25
100/38	70/32	60/27	50/23

Based on an average ice slab weight of 1.0 – 1.3 lb (400 – 600g)

## QM45 OPERATING TEMPERATURES

NOTE: Suction temp drops gradually throughout the freeze cycle.

### 50°F (10°C) Water

Air Temp. Entering Condenser	Freeze Cycle		Harvest Cycle	
	Discharge Temp °F (°C)	Suction Temp °F (°C)	Discharge Temp °F (°C)	Suction Temp °F (°C)
50°F (10°C)	150-165 (66-74)	67-50 (19-10)	155-190 (68-88)	50-60 (10-16)
70°F (21°C)	155-185 (68-85)	67-50 (19-10)	160-190 (71-88)	50-60 (10-16)
80°F (27°C)	170-190 (78-88)	71-58 (22-14)	175-190 (79-88)	52-65 (11-18)
90°F (32°C)	180-205 (82-96)	75-65 (24-18)	185-210 (85-99)	55-70 (13-21)
100°F (39°C)	190-215 (88-102)	85-70 (29-21)	195-220 (91-104)	60-75 (16-24)

### 70°F (21°C) Water

Air Temp. Entering Condenser	Freeze Cycle		Harvest Cycle	
	Discharge Temp °F (°C)	Suction Temp °F (°C)	Discharge Temp °F (°C)	Suction Temp °F (°C)
50°F (10°C)	155-175 (68-79)	68-58 (20-14)	160-175 (71-79)	50-60 (10-16)
70°F (21°C)	160-185 (71-85)	70-50 (21-10)	160-190 (71-85)	50-65 (10-18)
80°F (27°C)	170-200 (77-93)	75-58 (24-14)	170-200 (77-94)	55-70 (13-21)
90°F (32°C)	180-205 (82-96)	85-65 (29-18)	185-210 (85-99)	55-75 (13-24)
100°F (39°C)	190-220 (88-104)	88-70 (31-21)	200-220 (93-104)	60-75 (16-24)

### 90°F (32°C) Water

Air Temp. Entering Condenser	Freeze Cycle		Harvest Cycle	
	Discharge Temp °F (°C)	Suction Temp °F (°C)	Discharge Temp °F (°C)	Suction Temp °F (°C)
50°F (10°C)	155-180 (68-82)	75-50 (24-10)	160-185 (71-85)	52-65 (11-18)
70°F (21.1°C)	160-185 (71-85)	75-53 (24-12)	165-190 (74-88)	52-65 (11-18)
80°F (26.7°C)	170-195 (77-91)	80-58 (27-14)	175-195 (79-91)	57-75 (14-24)
90°F (32.2°C)	190-205 (88-96)	85-64 (29-18)	195-215 (91-102)	55-75 (13-24)
100°F (38.8°C)	190-215 (88-102)	91-70 (33-21)	195-220 (91-104)	60-80 (16-27)

## SM50 SELF-CONTAINED AIR-COOLED

NOTE: These characteristics may vary depending on operating conditions.

### Cycle Times

Freeze Time + Harvest Time = Total Cycle Time

Air Temp. Entering Condenser °F/°C	Freeze Time			Harvest Time
	Water Temperature °F/°C			
	50/10	70/21	90/32	
70/21	15.6-17.8	15.3-17.4	15.6-17.8	1.0-3.5
80/27	16.6-18.9	17.0-19.4	17.4-19.8	
90/32	17.4-19.8	19.1-21.7	18.2-20.7	
100/38	19.2-22.1	19.8-22.7	22.4-25.4	
110/43	24.9-28.2	25.7-29.1	31.4-35.5	

Times in minutes

### 24 Hour Ice Production

Air Temp. Entering Condenser °F/°C	Water Temperature °F/°C		
	50/10	70/21	90/32
70/21	53	54	53
80/27	50	49	48
90/32	48	44	46
100/38	40	39	38
110/43	35	34	28

Based on the average weight of 1 harvest cycle .63 – .71 lb  
(286 – 322 g).

Nominal Individual Cube Weight .70 ounces (20 g)

Cubes Per Harvest Cycle 16

### Operating Pressures

Air Temp. Entering Condenser °F/°C	Freeze Cycle		Harvest Cycle	
	Discharge Pressure PSIG	Suction Pressure PSIG	Discharge Pressure PSIG	Suction Pressure PSIG
50/10	125-70	18-0	50-75	20-55
70/21	135-95	18-0	65-85	35-60
80/27	165-115	19-2	75-100	40-70
90/32	195-135	20-3	85-120	40-70
100/38	235-165	24-5	100-135	50-80
110/43	255-185	28-7	110-155	50-90

Suction pressure drops gradually throughout the freeze cycle



## Q130 SELF-CONTAINED AIR-COOLED (Before Serial Number 310047287)

NOTE: These characteristics may vary depending on operating conditions.

### Cycle Times

Freeze Time + Harvest Time = Total Cycle Time

Air Temp. Entering Condenser °F/°C	Freeze Time			Harvest Time
	Water Temperature °F/°C			
	50/10	70/21	90/32	
70/21	10.2-11.7	12.4-14.1	14.6-16.5	1.0-2.5
80/27	11.2-12.8	13.0-14.8	15.5-17.5	
90/32	13.0-14.8	15.5-17.5	17.6-19.9	
100/38	14.6-16.5	17.6-19.9	20.3-23.0	

Times in minutes

### 24 Hour Ice Production

Air Temp. Entering Condenser °F/°C	Water Temperature °F/°C		
	50/10.0	70/21.1	90/32.2
70/21.1	130	110	95
80/26.7	120	105	90
90/32.2	105	90	80
100/37.8	95	80	70

Based on average ice slab weight of 1.06-1.19 lb (481 – 540 g).  
Regular cube derate is 7%

### Operating Pressures

Air Temp. Entering Condenser °F/°C	Freeze Cycle		Harvest Cycle	
	Discharge Pressure PSIG	Suction Pressure PSIG	Discharge Pressure PSIG	Suction Pressure PSIG
50/10	220-255	54-20	150-180	80-110
70/21	220-270	54-20	160-190	90-115
80/27	220-300	56-22	180-200	100-120
90/32	250-340	58-24	190-210	110-130
100/38	280-380	60-26	220-240	120-140
110/43	290-400	62-28	230-260	120-160

Suction pressure drops gradually throughout the freeze cycle

## Q130 SELF-CONTAINED AIR-COOLED (After Serial Number 310047287)

NOTE: These characteristics may vary depending on operating conditions.

### Cycle Times

Freeze Time + Harvest Time = Total Cycle Time

Air Temp. Entering Condenser °F/°C	Freeze Time			Harvest Time
	Water Temperature °F/°C			
	50/10	70/21	90/32	
70/21	10.2-12.4	12.3-14.8	14.3-17.2	0.75-2.5
80/27	11.7-14.1	13.6-16.3	16.1-19.3	
90/32	13.6-16.3	15.2-18.2	18.3-21.9	
100/38	15.2-18.2	18.3-21.9	21.1-25.2	

Times in minutes

### 24 Hour Ice Production

Air Temp. Entering Condenser °F/°C	Water Temperature °F/°C		
	50/10	70/21	90/32
70/21	135	115	100
80/27	120	105	90
90/32	105	95	80
100/38	95	80	70

Based on average ice slab weight of 1.06-1.19 lb (481 – 540 g).  
Regular cube derate is 7%

### Operating Pressures

Air Temp. Entering Condenser °F/°C	Freeze Cycle		Harvest Cycle	
	Discharge Pressure PSIG	Suction Pressure PSIG	Discharge Pressure PSIG	Suction Pressure PSIG
50/10	200-255	55-28	135-170	80-110
70/21	200-255	60-28	140-170	90-120
80/27	220-265	65-29	145-190	100-130
90/32	250-320	70-31	155-200	110-150
100/38	300-380	80-33	100-235	120-180
110/43	330-400	90-34	200-250	140-190

Suction pressure drops gradually throughout the freeze cycle

## Q130 SELF-CONTAINED WATER-COOLED

NOTE: These characteristics may vary depending on operating conditions.

### Cycle Times

Freeze Time + Harvest Time = Total Cycle Time

Air Temp. Around Ice Machine °F/°C	Freeze Time			Harvest Time
	Water Temperature °F/°C			
	50/10	70/21	90/32	
70/21	10.2-12.4	12.3-14.8	14.3-17.2	1.0-2.5
80/27	10.7-12.9	12.3-14.8	15.2-18.2	
90/32	10.7-12.9	12.9-15.5	15.2-18.2	
100/38	11.2-13.5	12.9-15.5	16.1-19.3	

Times in minutes

### 24 Hour Ice Production

Air Temp. Around Ice Machine °F/°C	Water Temperature °F/°C		
	50/10	70/21	90/32
70/21	135	115	100
80/27	130	115	95
90/32	130	110	95
100/38	125	110	90

Based on average ice slab weight of 1.06 - 1.19 lb (481 – 540 g).  
Regular cube derate is 7%

Condenser Water Consumption	90/32 Air Temperature Around Ice Machine		
	Water Temperature °F/°C		
	50/10	70/21	90/32
Gal/24 hours	150	200	460

Water regulating valve set to maintain 250 PSIG discharge pressure

### Operating Pressures

Air Temp. Around Ice Machine °F/°C	Freeze Cycle		Harvest Cycle	
	Discharge Pressure PSIG	Suction Pressure PSIG	Discharge Pressure PSIG	Suction Pressure PSIG
50/10	225-235	54-20	160-180	80-110
70/21	225-235	54-21	160-190	80-115
80/27	225-240	55-22	165-200	90-120
90/32	225-245	56-22	165-200	95-125
100/38	225-245	57-22	170-200	100-130
110/43	225-245	58-23	180-210	105-140

Suction pressure drops gradually throughout the freeze cycle

## Q170 SELF-CONTAINED AIR-COOLED

NOTE: These characteristics may vary depending on operating conditions.

NOTE: Data is preliminary.

### Cycle Times

Freeze Time + Harvest Time = Total Cycle Time

Air Temp. Entering Condenser °F/°C	Freeze Time			Harvest Time
	Water Temperature °F/°C			
	50/10	70/21	90/32	
70/21	17.6-20-1	NA	24.5-28.0	1.0-2.5
80/27	NA	20.9-23.9	NA	
90/32	20.9-23.9	24.5-28.0	28.1-31.9	
100/38	NA	NA	33.7-38.3	

Times in minutes

### 24 Hour Ice Production

Air Temp. Entering Condenser °F/°C	Water Temperature °F/°C		
	50/10	70/21	90/32
70/21	175	NA	130
80/27	NA	150	NA
90/32	150	130	115
100/38	NA	NA	97

Based on average ice slab weight of 2.44 - 2.75 lb (1107 – 1247 g).  
Regular cube derate is 7%

### Operating Pressures

Air Temp. Entering Condenser °F/°C	Freeze Cycle		Harvest Cycle	
	Discharge Pressure PSIG	Suction Pressure PSIG	Discharge Pressure PSIG	Suction Pressure PSIG
50/10	220-280	60-38	150-170	90-110
70/21	220-280	60-38	150-170	95-115
80/27	240-290	70-38	160-190	100-120
90/32	280-330	75-38	180-210	160-140
100/38	310-380	85-41	200-230	120-160
110/43	315-390	90-41	200-240	140-170

Suction pressure drops gradually throughout the freeze cycle

## Q210 SELF-CONTAINED AIR-COOLED

NOTE: These characteristics may vary depending on operating conditions.

### Cycle Times

Freeze Time + Harvest Time = Total Cycle Time

Air Temp. Entering Condenser °F/°C	Freeze Time			Harvest Time
	Water Temperature °F/°C			
	50/10	70/21	90/32	
70/21	14.8-16.9	17.5-19.9	19.8-22.5	1.0-2.5
80/27	16.1-18.3	19.2-21.8	21.9-24.9	
90/32	17.5-19.9	21.2-24.0	24.5-27.8	
100/38	19.2-21.8	23.6-26.8	27.8-31.5	

Times in minutes

### 24 Hour Ice Production

Air Temp. Entering Condenser °F/°C	Water Temperature °F/°C		
	50/10	70/21	90/32
70/21	215	185	165
80/27	200	170	150
90/32	185	155	135
100/38	170	140	120

Based on average ice slab weight of 2.44 - 2.75 lb (1107 – 1247 g).  
Regular cube derate is 7%

### Operating Pressures

Air Temp. Entering Condenser °F/°C	Freeze Cycle		Harvest Cycle	
	Discharge Pressure PSIG	Suction Pressure PSIG	Discharge Pressure PSIG	Suction Pressure PSIG
50/10	220-270	60-36	180-205	90-110
70/21	220-270	60-36	185-210	95-115
80/27	235-280	66-36	190-215	100-120
90/32	265-310	70-38	200-225	105-125
100/38	310-360	76-40	220-245	110-130
110/43	320-380	80-42	230-255	115-135

Suction pressure drops gradually throughout the freeze cycle

## Q210 SELF-CONTAINED WATER-COOLED

NOTE: These characteristics may vary depending on operating conditions.

### Cycle Times

Freeze Time + Harvest Time = Cycle Time

Air Temp. Around Ice Machine °F/°C	Freeze Time			Harvest Time
	Water Temperature °F/°C			
	50/10	70/21	90/32	
70/21	14.5-16.5	15.6-17.8	19.2-21.8	1.0-2.5
80/27	14.8-16.9	16.1-18.3	19.8-22.5	
90/32	15.6-17.8	17.0-19.3	21.2-24.0	
100/38	16.1-18.3	17.5-19.9	21.9-24.9	

Times in minutes

### 24 Hour Ice Production

Air Temp. Around Ice Machine °F/°C	Water Temperature °F/°C		
	50/10	70/21	90/32
70/21	220	205	170
80/27	215	200	165
90/32	205	190	155
100/38	200	185	150

Based on average ice slab weight of 2.44 - 2.75 lb (1107 – 1247 g).  
Regular cube derate is 7%

Condenser Water Consumption	90/32 Air Temperature Around Ice Machine		
	Water Temperature °F/°C		
	50/10	70/21	90/32
Gal/24 hours	160	270	1500

Water regulating valve set to maintain 230 PSIG discharge pressure

### Operating Pressures

Air Temp. Around Ice Machine °F/°C	Freeze Cycle		Harvest Cycle	
	Discharge Pressure PSIG	Suction Pressure PSIG	Discharge Pressure PSIG	Suction Pressure PSIG
50/10	225-235	60-35	160-180	70-95
70/21	225-235	60-36	160-180	70-95
80/27	225-235	60-36	165-185	80-100
90/32	225-240	60-37	170-190	90-115
100/38	225-240	60-38	175-195	100-120
110/43	225-245	60-38	180-200	100-120

Suction pressure drops gradually throughout the freeze cycle.

## Q270 SELF-CONTAINED AIR-COOLED

NOTE: These characteristics may vary depending on operating conditions.

### Cycle Times

Freeze Time + Harvest Time = Total Cycle Time

Air Temp. Entering Condenser °F/°C	Freeze Time			Harvest Time
	Water Temperature °F/°C			
	50/10	70/21	90/32	
70/21	11.0-12.6	12.8-14.7	14.5-16.5	1.0-2.5
80/27	11.3-12.9	13.1-15.0	14.8-16.9	
90/32	12.6-14.3	14.8-16.9	17.0-19.3	
100/38	14.1-16.1	17.0-19.3	19.8-22.5	

Times in minutes

### 24 Hour Ice Production

Air Temp. Entering Condenser °F/°C	Water Temperature °F/°C		
	50/10	70/21	90/32
70/21	280	245	220
80/27	275	240	215
90/32	250	215	190
100/38	225	190	165

Based on average ice slab weight of 2.44 - 2.75 lb (1107 – 1247 g).  
Regular cube derate is 7%

### Operating Pressures

Air Temp. Entering Condenser °F/°C	Freeze Cycle		Harvest Cycle	
	Discharge Pressure PSIG	Suction Pressure PSIG	Discharge Pressure PSIG	Suction Pressure PSIG
50/10	200-255	60-22	165-200	70-95
70/21	200-255	60-22	170-205	70-100
80/27	200-295	61-23	175-210	75-100
90/32	240-330	65-26	205-240	80-100
100/38	265-375	66-30	220-260	85-115

Suction pressure drops gradually throughout the freeze cycle

## Q270 SELF-CONTAINED WATER-COOLED

NOTE: These characteristics may vary depending on operating conditions.

### Cycle Times

Freeze Time + Harvest Time = Total Cycle Time

Air Temp. Around Ice Machine °F/°C	Freeze Time			Harvest Time
	Water Temperature °F/°C			
	50/10	70/21	90/32	
70/21	10.6-12.2	12.3-14.0	13.5-15.4	1.0-2.5
80/27	10.8-12.4	12.6-14.3	13.8-15.7	
90/32	11.0-12.6	12.8-14.7	14.1-16.1	
100/38	11.3-12.9	13.1-15.0	14.5-16.5	

Times in minutes

### 24 Hour Ice Production

Air Temp. Around Ice Machine °F/°C	Water Temperature °F/°C		
	50/10	70/21	90/32
70/21	290	255	235
80/27	285	250	230
90/32	280	245	225
100/8	275	240	220

Based on average ice slab weight of 2.44 - 2.75 lb (1107 – 1247 g).  
Regular cube derate is 7%

Condenser Water Consumption	90/32 Air Temperature Around Ice Machine		
	Water Temperature °F/°C		
	50/10	70/21	90/32
Gal/24 hours	240	410	2740

Water regulating valve set to maintain 240 PSIG discharge pressure

### Operating Pressures

Air Temp. Around Ice Machine °F/°C	Freeze Cycle		Harvest Cycle	
	Discharge Pressure PSIG	Suction Pressure PSIG	Discharge Pressure PSIG	Suction Pressure PSIG
50/10	235-245	52-24	175-210	80-95
70/21	235-245	54-24	175-210	80-95
80/27	235-250	56-24	175-210	80-95
90/32	235-255	58-24	175-210	80-95
100/38	235-260	60-24	175-210	80-95

Suction pressure drops gradually throughout the freeze cycle



# Diagrams

---

## Wiring Diagrams

The following pages contain electrical wiring diagrams. Be sure you are referring to the correct diagram for the ice machine you are servicing.



### Warning

Always disconnect power before working on electrical circuitry.

## Wiring Diagram Legend

The following symbols are used on all of the wiring diagrams:

- \* Internal Compressor Overload  
(Some models have external compressor overloads)
- \*\* Fan Motor Run Capacitor  
(Some models do not incorporate fan motor run capacitor)
- ( ) Wire Number Designation  
(The number is marked at each end of the wire)
- >>— Multi-pin Connection  
(Electrical Box Side) —>>—  
(Compressor Compartment Side)

# QM20

CAUTION: DISCONNECT POWER BEFORE WORKING ON ELECTRICAL CIRCUITRY.  
 NOTE: DIAGRAM SHOWN DURING THE FREEZE CYCLE.  
 SEE SERIAL PLATE FOR VOLTAGE.

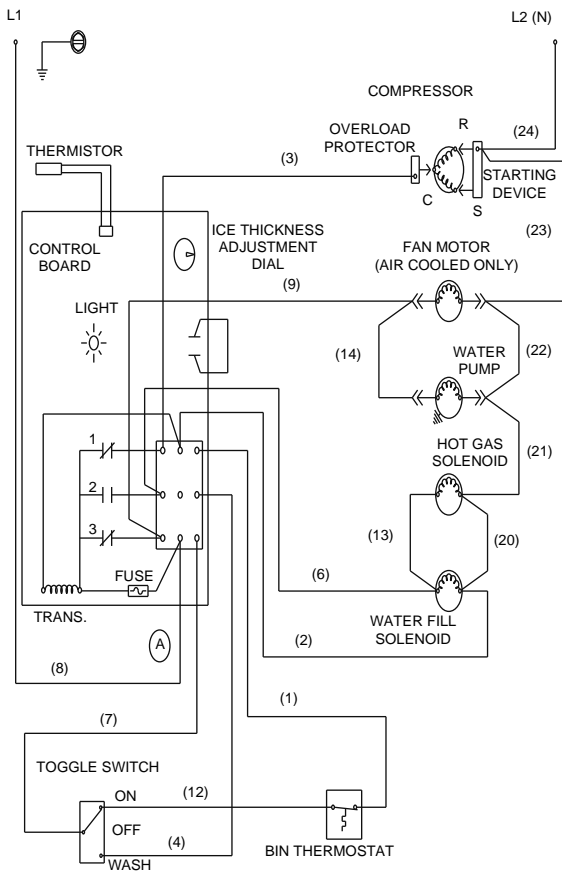

( ) - WIRE NUMBER DESIGNATION  
 (IS MARKED AT EACH END OF WIRE)  
 —<< - FEMALE/MALE CONNECTOR

SV1774

# QM30

## 115V/1 Ph/60 Hz

CAUTION: DISCONNECT POWER BEFORE WORKING ON ELECTRICAL CIRCUITRY.

NOTE: DIAGRAM SHOWN DURING THE FREEZE CYCLE.

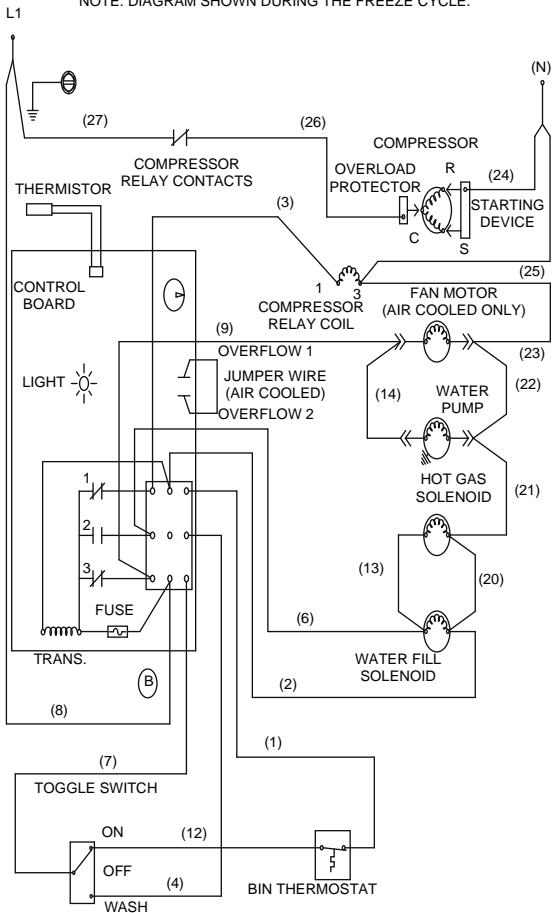

( ) - WIRE NUMBER DESIGNATION  
(IS MARKED AT EACH END OF WIRE)

—<< - FEMALE/MALE CONNECTOR

SV1775

# QM30

## 230V/1 Ph/50 Hz

CAUTION: DISCONNECT POWER BEFORE WORKING ON ELECTRICAL CIRCUITRY.

NOTE: DIAGRAM SHOWN DURING THE FREEZE CYCLE. SEE SERIAL PLATE FOR VOLTAGE.

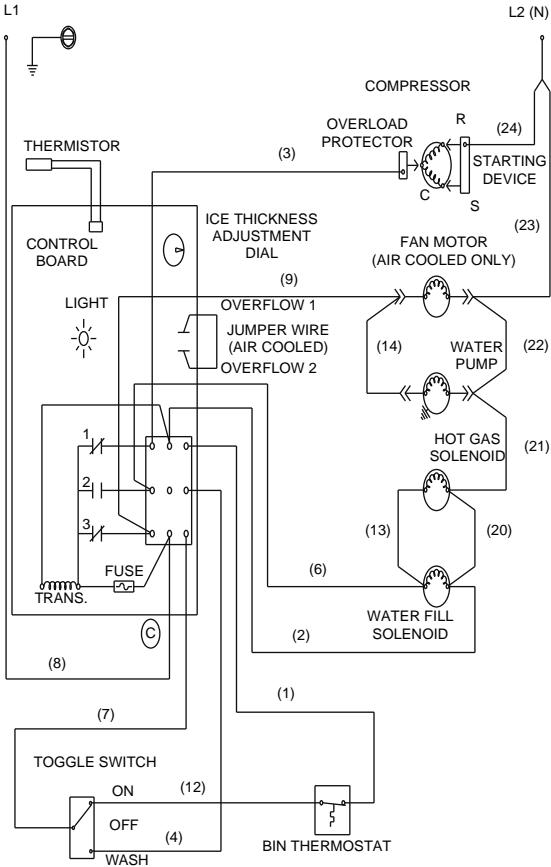

( ) - WIRE NUMBER DESIGNATION  
(IS MARKED AT EACH END OF WIRE)

—♀♂— - FEMALE/MALE CONNECTOR

SV1773

# QM45

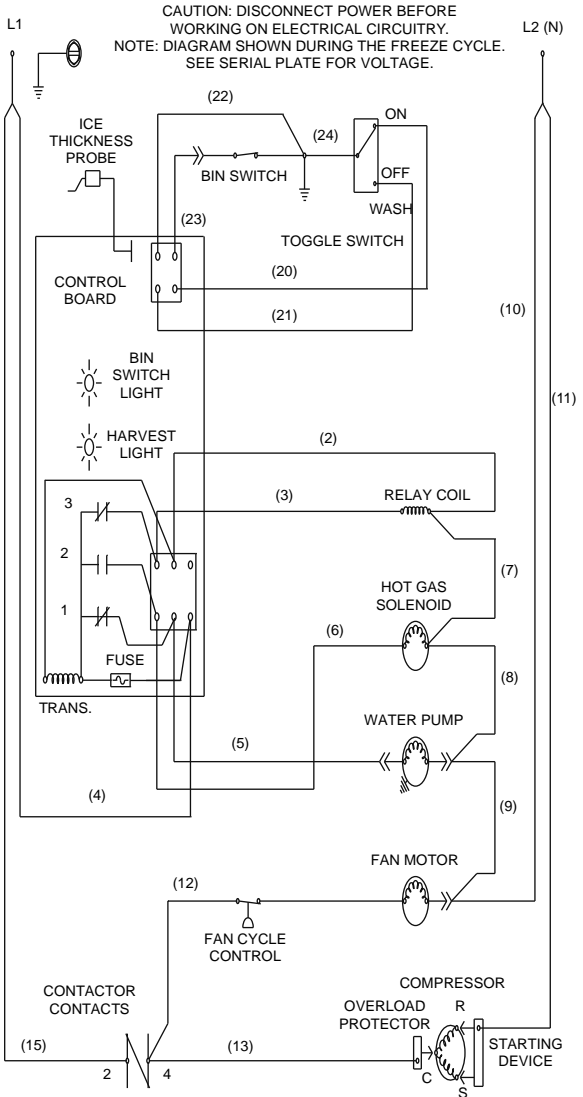

SV1776

# SM50

CAUTION: DISCONNECT POWER BEFORE WORKING ON ELECTRICAL CIRCUITRY.  
NOTE: DIAGRAM SHOWN DURING THE FREEZE CYCLE.

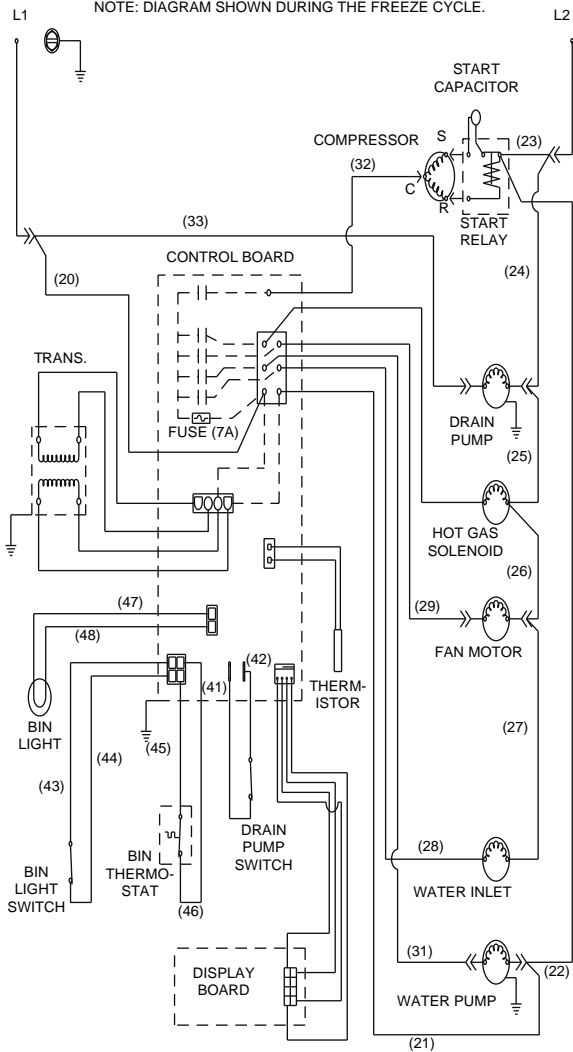

# Q130/Q210

## Tecumseh Compressor

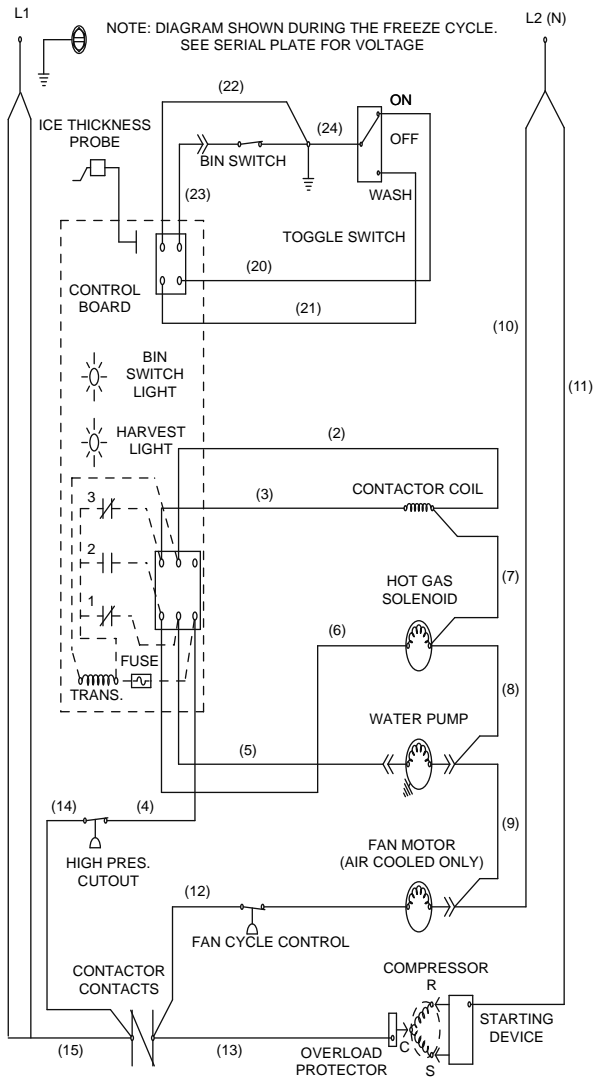

# Q130/Q170/Q210

## Danfoss Compressor

NOTE: DIAGRAM SHOWN DURING THE FREEZE CYCLE.  
SEE SERIAL PLATE FOR VOLTAGE

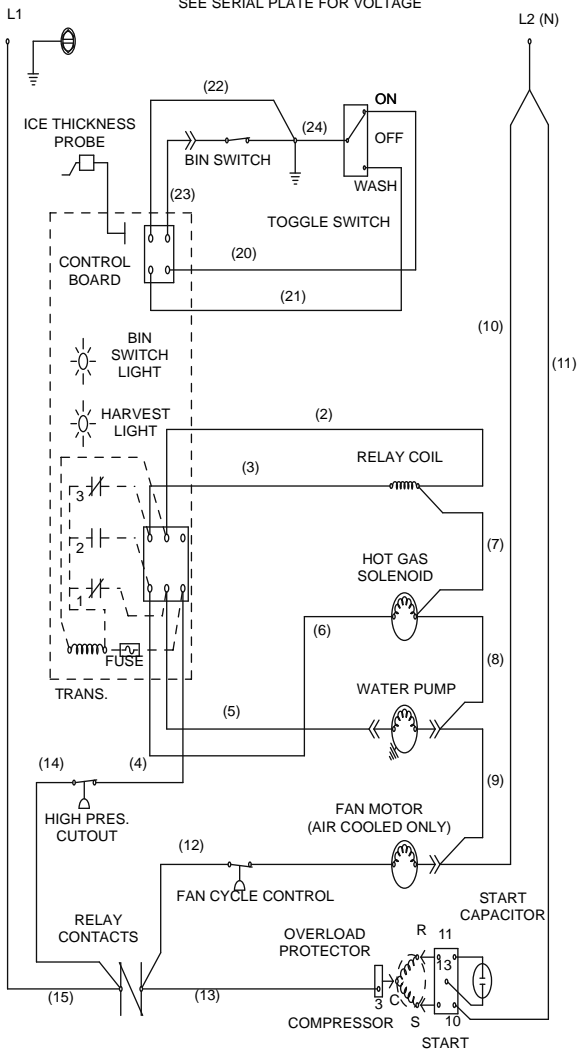



# Q270

## Tecumseh Compressor

CAUTION: DISCONNECT POWER BEFORE WORKING ON ELECTRICAL CIRCUITRY.  
 DIAGRAM SHOWN DURING THE FREEZE CYCLE.  
 SEE SERIAL PLATE FOR VOLTAGE

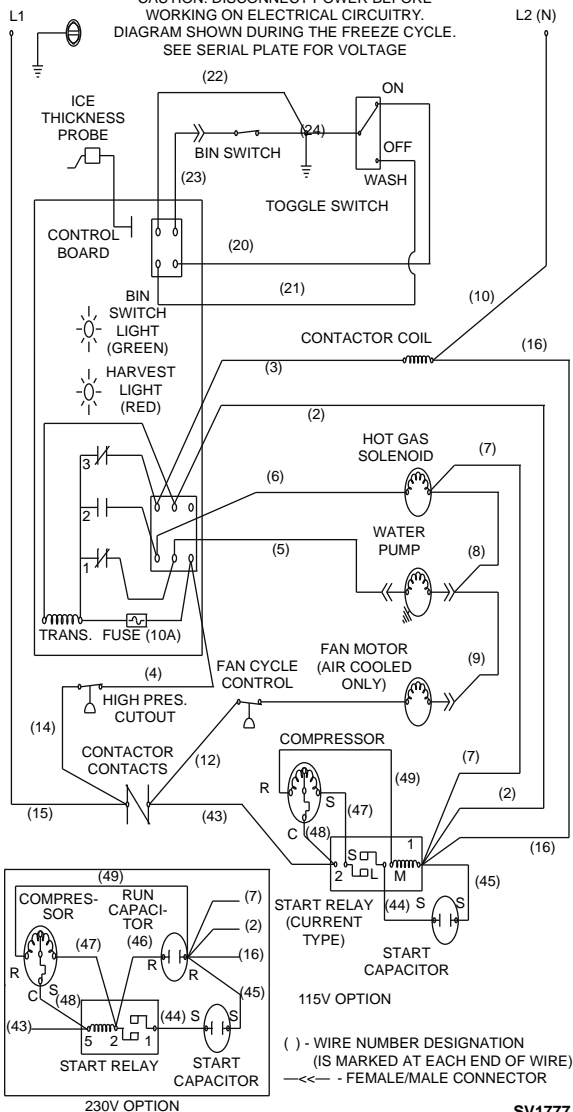

# Q270

## Danfoss Compressor

NOTE: DIAGRAM SHOWN DURING THE FREEZE CYCLE.  
SEE SERIAL PLATE FOR VOLTAGE

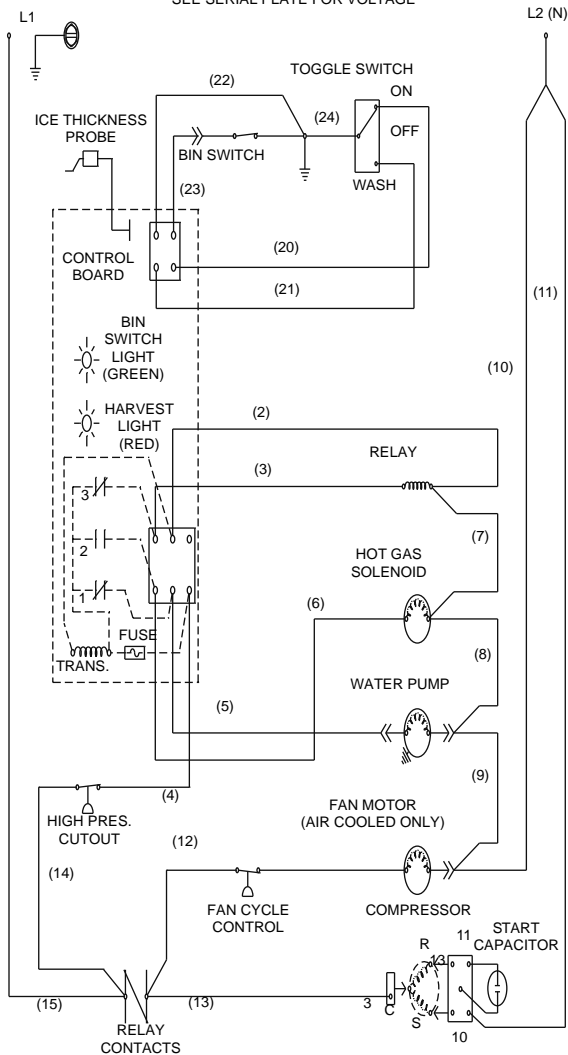

# Electronic Control Boards

QM20/QM30

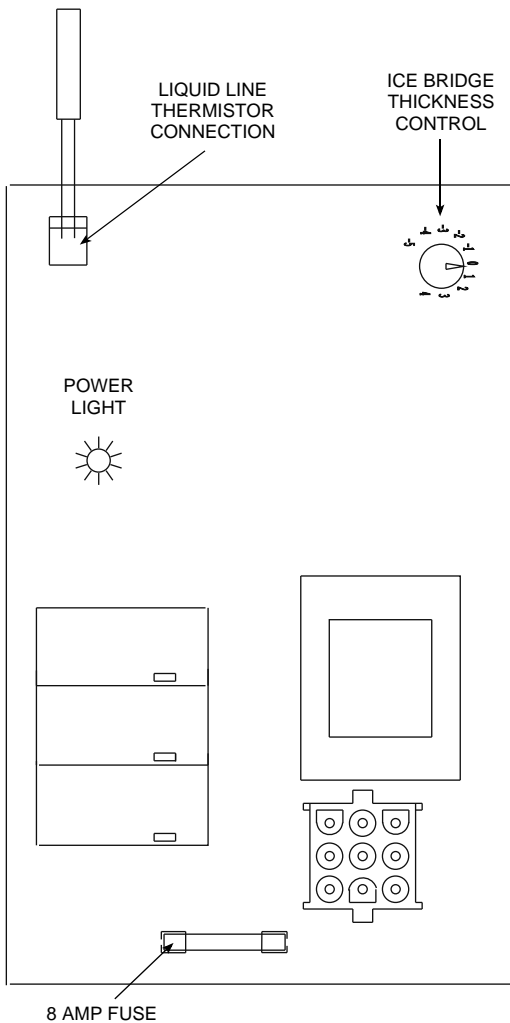

# QM45/Q130/Q170/Q210/Q270

ICE THICKNESS  
PROBE

DC LOW VOLTAGE  
ELECTRICAL PLUG

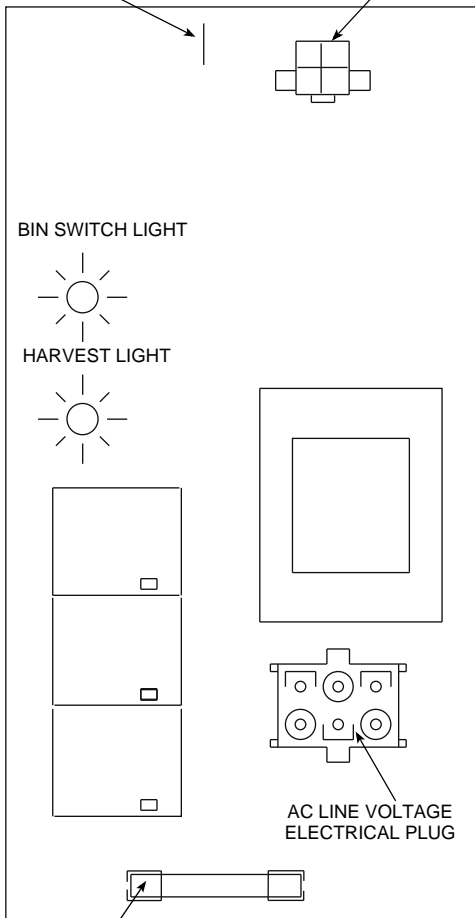

10 AMP FUSE

# SM50

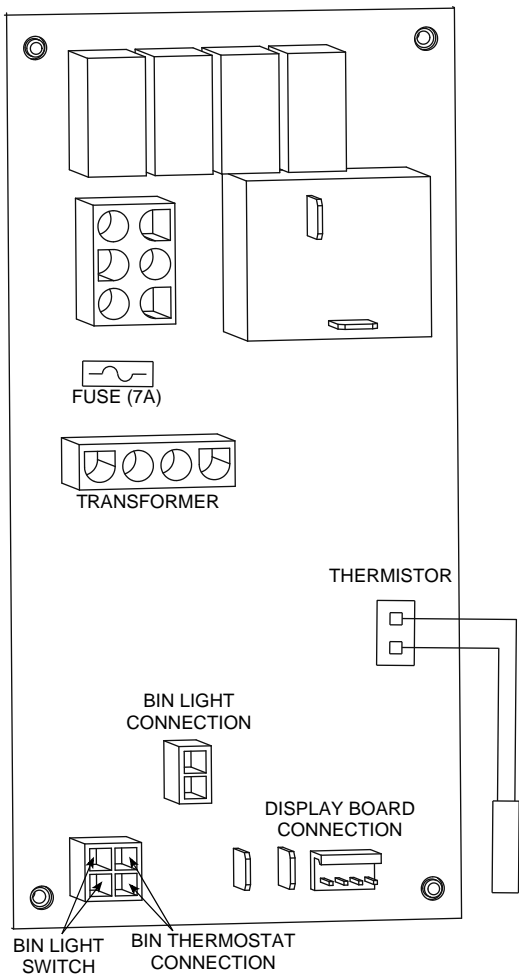

# Tubing Schematics

## QM20/QM30 Tubing Schematic

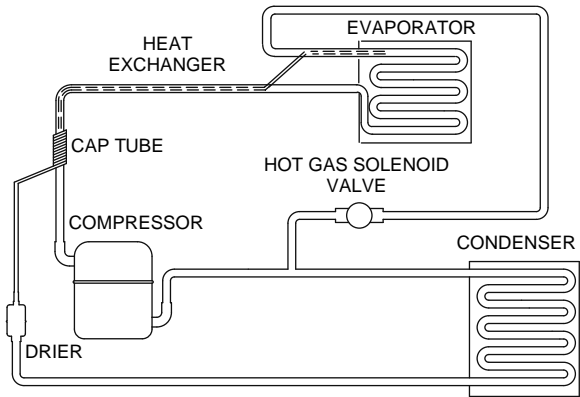

SV3022

# QM45/Q130 Tubing Schematic

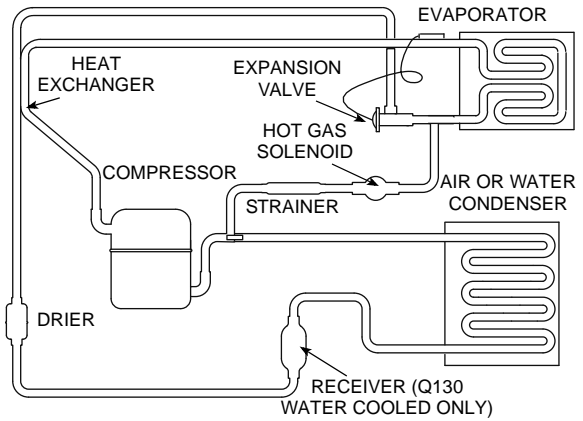

SV3024

## SM50 Tubing Schematic

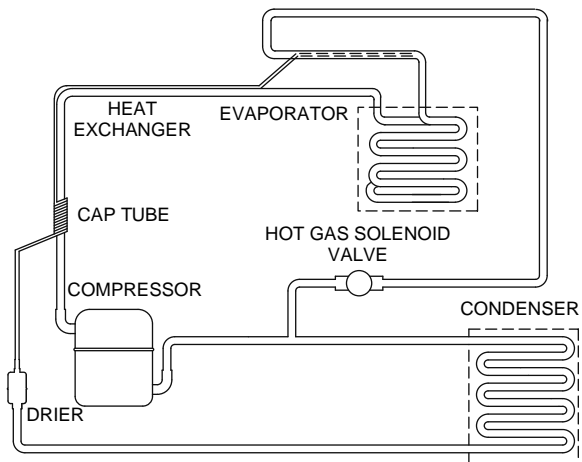



## Q170/Q210/Q270 Tubing Schematic

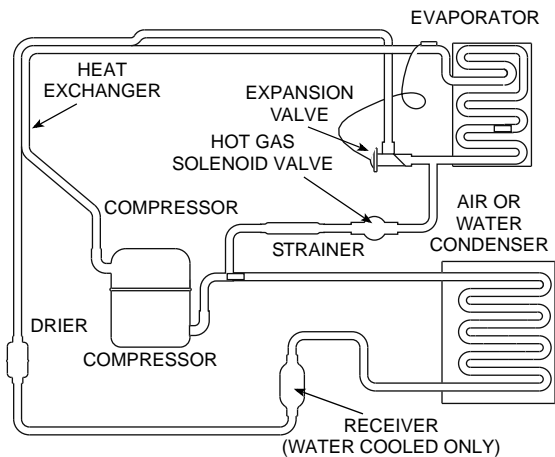

SV3023

**This Page Intentionally Left Blank**





© 2008 Manitowoc  
Part Number 80-0111-9 6/11

**Manitowoc Foodservice**  
2110 South 26th Street, P.O. Box 1720  
Manitowoc, WI 54221-1720, USA  
Ph: 920-682-0161 Fax: 920-683-7589  
Visit us online at: [www.manitowocice.com](http://www.manitowocice.com)