

Manitowoc®

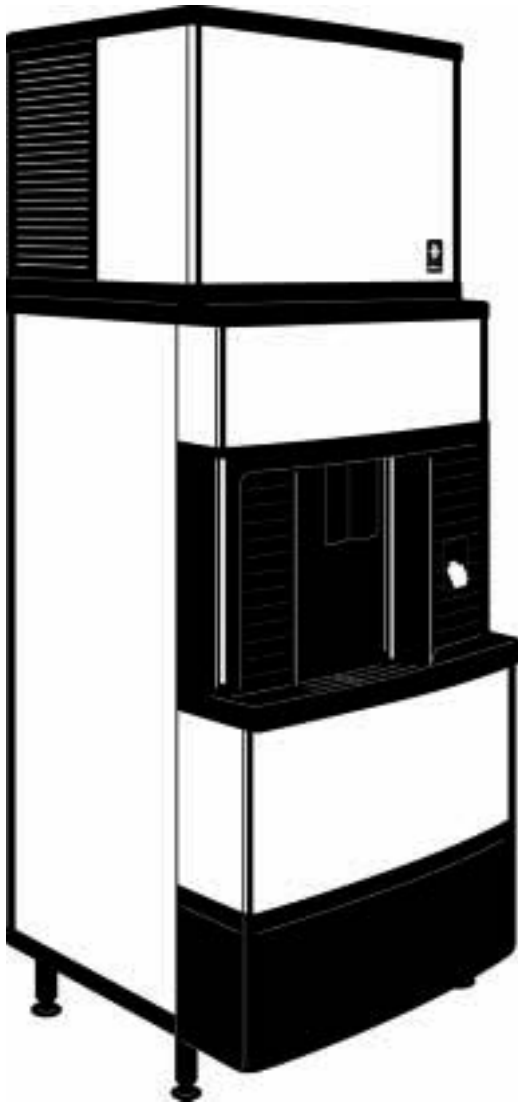

Q Model Dispenser

Installation, Use, Care, and Service Manual

Thank you for selecting a Manitowoc Dispenser, the dependability leader in ice making equipment and related products. With proper care and maintenance, your new Manitowoc Dispenser will provide you with many years of reliable and economical performance.

Safety Notices

When using or servicing a Q Model Dispenser, be sure to pay close attention to the safety notices in this manual. Disregarding the notices may lead to serious injury and/or damage to the dispenser.

Throughout this manual, you will see the following types of safety notices:

WARNING

Text in a Warning box alerts you to a potential personal injury situation. Be sure to read the Warning statement, and then proceed carefully.

CAUTION

Text in a Caution box alerts you to a situation in which you could damage the dispenser. Be sure to read the Caution statement, and then proceed carefully.

CAUTION

Proper care and maintenance are essential for trouble-free operation of your Manitowoc Dispenser.

Read and understand this manual. It contains valuable care and maintenance information. If you encounter problems not covered by this manual, feel free to contact Manitowoc Ice, Inc. We will be happy to provide assistance.

Procedural Notices

When using or servicing a Q Model Dispenser, be sure to read the procedural notices in this manual. These notices supply helpful and important information.

Throughout this manual, you will see the following types of procedural notices:

Important

Important boxes serve two functions.

They call the operator's attention to important information.

They also provide the service technician with information that may help in performing a procedure more efficiently. Disregarding this information may slow down the work.

NOTE: Text set off as a Note provides you with simple, but useful, extra information.

Dispensers Covered In This Manual

FLOOR-STANDING MODELS

QFA-291 Glass Fill Dispensers

HOTEL/MOTEL DISPENSERS

QPA-310 Push Button Operated

QRA-340 Card Operated

QCA-330 Coin Operated

NOTE: These dispensers are designed to dispense both dice and half dice ice.

NOTE: These dispensers may be used in conjunction with a Manitowoc ice machine for automatic fill of dispenser.

NOTE: These dispensers are capable of storing 180 lbs (82 kgs) of ice.

Table of Contents

Section 1 - General Information

Model/Serial Number Location	1-1
Owner Warranty Registration Card.....	1-2
Warranty Coverage	1-2

Section 2 - Installation Instructions

Dimensions.....	2-1
General Installation Information	2-2
Location of Dispenser	2-3
Leveling the Dispenser.....	2-3
Electrical Service.....	2-4
Water Service/Drains	2-5

Section 3 - Dispenser Operation

Method of Operation (All Models)	3-1
Rate of Delivery.....	3-1
Sequence of Operation.....	3-2

Section 4 - Maintenance

General.....	4-1
Dispenser Inspection.....	4-1
Exterior Cleaning.....	4-1
Cleaning and Sanitizing.....	4-1
Removal of Parts	4-3
Removal from Service/Winterization.....	4-4

Section 5 - Before Calling for Service

Checklist	5-1
-----------------	-----

Section 6 - Service

Door Removal.....	6-1
Delivery Auger and Agitator Auger Removal.....	6-2
Delivery Auger	6-3
Agitator Auger	6-3
Belt Tightening and Replacement	6-3
Lower Bearing Assembly	6-4
Upper Bearing Assembly.....	6-5
Wiring Diagrams.....	6-6

Table of Contents

THIS PAGE INTENTIONALLY LEFT BLANK

**Section 1
General Information**

Model/Serial Number Location

Record the model and serial number of your dispenser in the space provided below. These numbers are required when requesting information from your Manitowoc distributor, service representative, or the factory.

The model and serial number are listed on the OWNER WARRANTY REGISTRATION CARD. They are also listed on the MODEL/SERIAL NUMBER DECAL affixed to the rear of the dispenser and also located inside the front door.

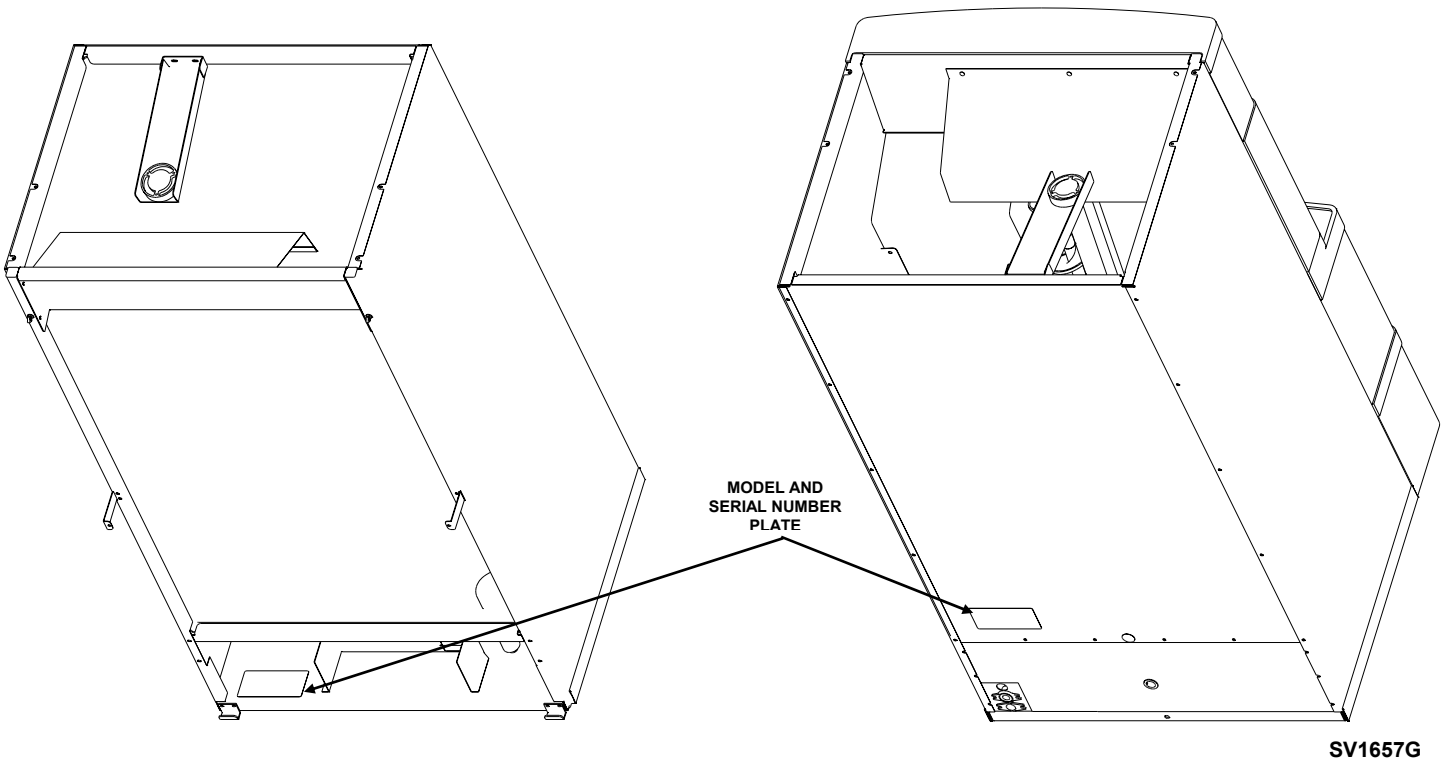

Model/Serial Number Location

MODEL NUMBER: _____

SERIAL NUMBER: _____

Owner Warranty Registration Card

GENERAL

The packet containing this manual also includes warranty information. Warranty coverage begins the day your new dispenser is installed.

Important

Complete and mail the OWNER WARRANTY REGISTRATION CARD as soon as possible to validate the installation date.

If you do not return your OWNER WARRANTY REGISTRATION CARD, Manitowoc will use the date of sale to the Manitowoc Distributor as the first day of warranty coverage for your new dispenser.

Warranty Coverage

GENERAL

The following Warranty outline is provided for your convenience. For a detailed explanation, read the warranty bond shipped with each product.

Contact your local Manitowoc representative or Manitowoc Ice, Inc. if you need further warranty information.

PARTS

Manitowoc warrants the dispenser against defects in materials and workmanship, under normal use and service, for three (3) years from the date of original installation.

LABOR

Labor required to repair or replace defective components is covered for three (3) years from the date of original installation.

EXCLUSIONS

The following items are not included in the dispenser's warranty coverage:

1. Normal maintenance, adjustments and cleaning as outlined in this manual.
2. Repairs due to unauthorized modifications to the dispenser or the use of non-standard parts without prior written approval from Manitowoc Ice, Inc.
3. Damage caused by improper installation of the dispenser, electrical supply, water supply or drainage, or damage caused by floods, storms, or other acts of God.
4. Premium labor rates due to holidays, overtime, etc.; travel time; flat rate service call charges; mileage and miscellaneous tools and material charges not listed on the payment schedule. Additional labor charges resulting from the inaccessibility of the dispenser are also excluded.
5. Parts or assemblies subjected to misuse, abuse, neglect or accidents.
6. Damage or problems caused by installation, cleaning and/or maintenance procedures inconsistent with the technical instructions provided in this manual.

AUTHORIZED WARRANTY SERVICE

To comply with the provisions of the warranty, a refrigeration service company, qualified and authorized by a Manitowoc distributor, or a Contracted Service Representative must perform the warranty repair.

NOTE: If the dealer the dispenser was purchased from is not authorized to perform warranty service, contact the Manitowoc distributor or Manitowoc Ice, Inc. for the name of the nearest authorized service representative.

SERVICE CALLS

If you have followed the procedures listed in Section 5 of this manual, and the dispenser still does not perform properly, call your authorized service company.

**Section 2
Installation Instructions**

Dimensions

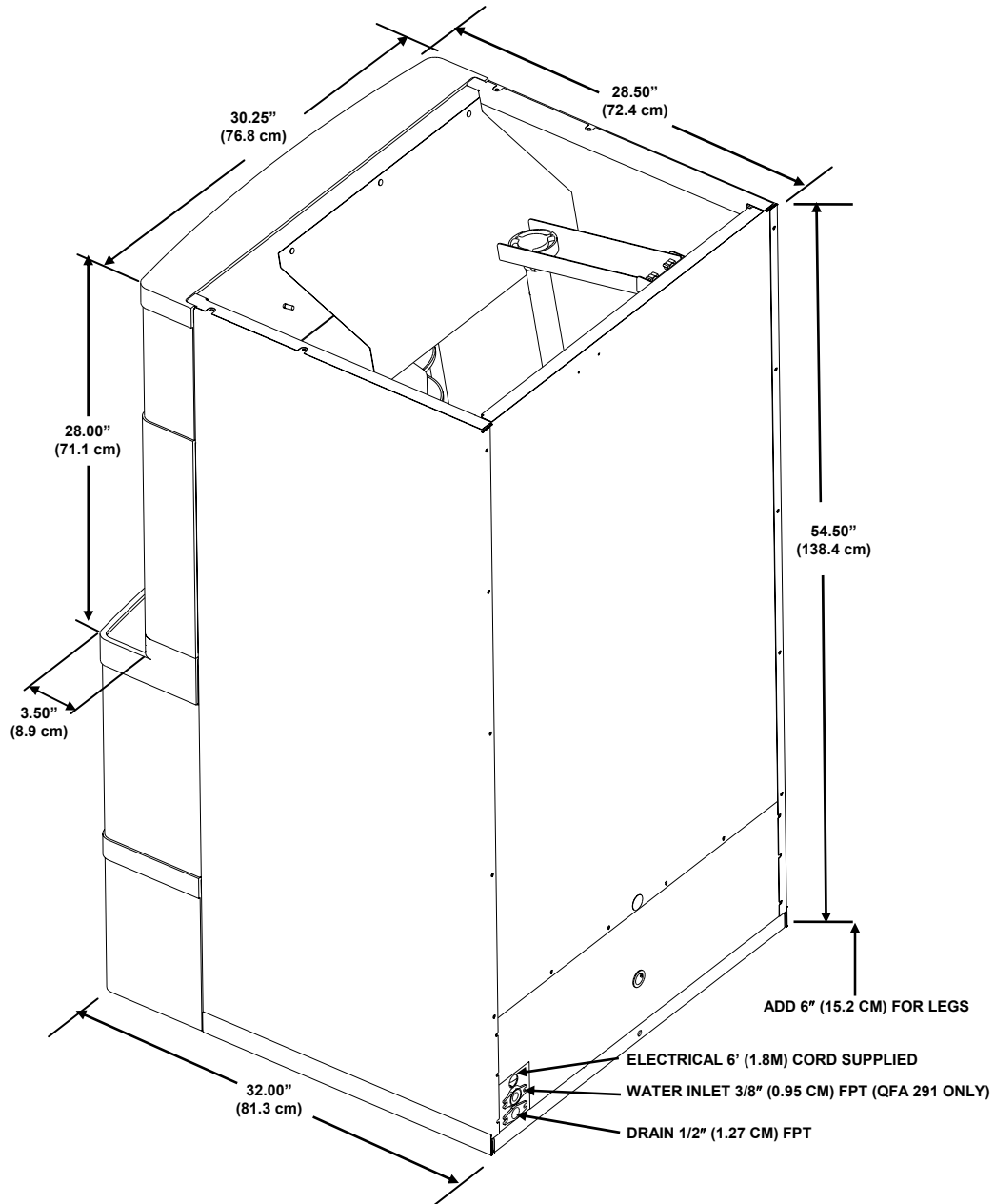

SV1658G

General Installation Information

DISPENSER INSTALLATION



CAUTION

This equipment is to be installed by trained and qualified personnel.

ICE MACHINE INSTALLATION

- Refer to the ice machine's Installation/Use and Care Guide for the ice machine installation procedure.
- Order adapter kit K00141, when installing a 22" Ice Machine with a Dispenser.
- Observe all clearance requirements (see location of dispenser on page 2-3).
- Install the mounting clip to connect the ice machine to the dispenser.
- Install legs on the dispenser (to access legs from their shipping position remove back panel).

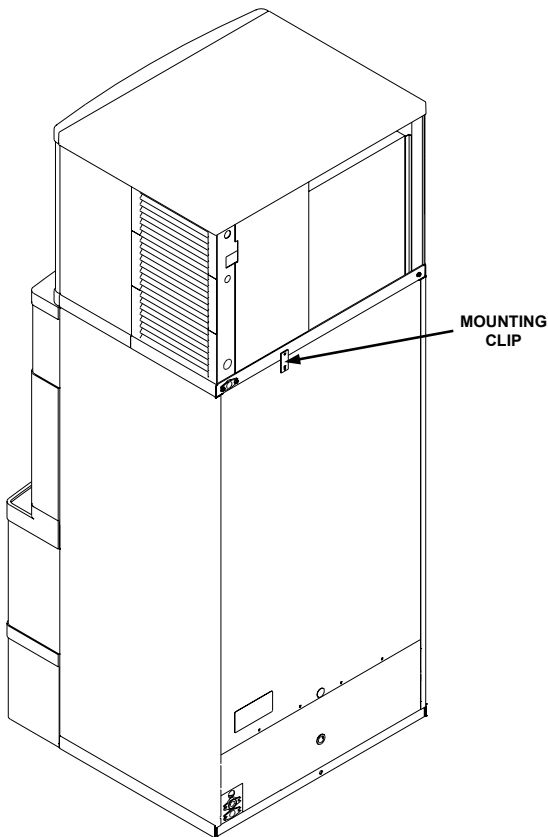

SV1659G

Mounting Clip Installation

MOUNTING CLIP INSTALLATION

1. Open the shipping envelope and remove the mounting clip (flat plate).
2. Remove the back panel lower mounting screw from the ice machine. Insert the screw through the bottom hole on the clip and reinstall the screw.
3. Remove the screw from the shipping envelope. Insert it through the top hole on the clip and into the pre-drilled 5/32" hole on the dispenser back.

NOTE: The ice machine's ice bridge thickness must be set for easy dispensing. Set the ice bridge as directed in the ice machine's Installation/Use and Care Guide.

The ice bridge setting must be set thin enough to allow the ice to break up easily, but thick enough to insure a clean harvest of the evaporator. An overly thick bridge will allow ice chunks to fall into the bin, preventing the sheet of cubes from breaking up for easy dispensing. This will cause a slower dispensing rate.



WARNING

Do not attempt to move a dispenser without first removing the ice machine. The combination can be unstable and could tip.

Location of Dispenser

The location selected for the dispenser must meet the following criteria. If any of these criteria are not met, select another location.

- The location must be indoors.
- The location must be free of airborne and other contaminants.
- The air temperature must be at least 35°F (1.6°C), but must not exceed 110°F (43.3°C).
- The location must not be near heat-generating equipment or in direct sunlight.
- The resting surface must be able to support 600 lb. (272 kg per square meter), which includes the dispenser, the ice machine and ice.
- The location must allow enough clearance for water, drain, and electrical connections in the rear of the dispenser. The location must not obstruct airflow.
- The dispenser has no minimum air clearance requirements. When installing an Ice Machine/Dispenser combination, follow the air clearance requirements for the Ice Machine being installed

CAUTION

The dispenser must be protected if it will be subjected to temperatures below 32°F (0°C). Failure caused by exposure to freezing temperatures is not covered by the warranty. See "Removal from Service/Winterization" on page 4-4.

Leveling the Dispenser

After moving the dispenser into the installation location, it must be leveled for proper operation. Follow these steps to level the dispenser:

1. Use a level to check the levelness of the ice machine from front to back and from side to side.

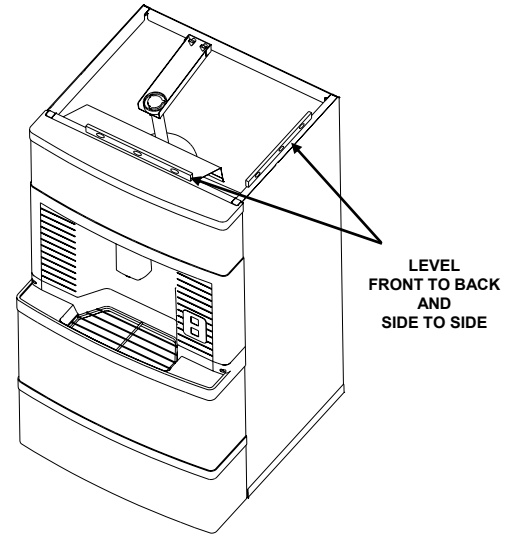

SV1660G

Checking Levelness

2. If the dispenser is not level, adjust the legs on each corner of the dispenser as necessary.
3. Check the levelness of the dispenser after each adjustment of the legs.
4. Repeat steps 2 and 3 until the dispenser is level from front to back and from side to side.

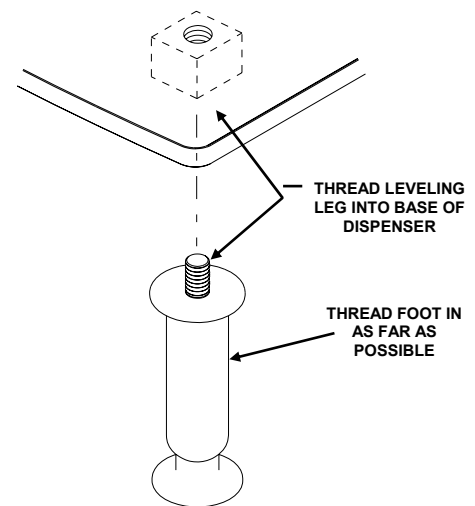

SV1606G

Leveling Leg

Electrical Service

GENERAL

 **WARNING**

All wiring must conform to local, state and national codes.

 **WARNING**

Never use an extension cord. If an outlet is not within reach of the dispenser power cord, have a proper amperage outlet wired closer to the dispenser.

Voltage Phase Cycle	Maximum Fuse/Circuit Breaker Minimum Circuit Amps
115/1/60	15 amp
230/1/50	15 amp

ELECTRICAL CORD STRAIN RELIEF

To prevent strain at the electrical connection inside the dispenser, an electrical cord strain relief device has been installed on the rear panel of the dispenser.

VOLTAGE

The maximum allowable voltage variation is $\pm 10\%$ of the rated voltage at dispenser start-up (when the electrical load is highest).

 **WARNING**

The dispenser must be grounded in accordance with national and local electrical codes.

FUSE/CIRCUIT BREAKER

A separate fuse/circuit breaker must be provided for each dispenser.

NOTE: A disconnect means must be provided for field wiring.

ELECTRICAL RATING

The electrical rating is used to help select the wire size of the electrical supply. The wire size (or gauge) also depends on location, materials used, length of run, etc., so it must be determined by a qualified electrician.

Water Service/Drains

WATER CONNECTIONS

Local water conditions may require treatment of the water to inhibit scale formation, filter sediment, and remove chlorine odor and taste.

Follow these guidelines to install water inlet lines:



CAUTION

Plumbing must conform to state and local codes.

- Connect to potable water supply only.
- Do not connect to a hot water supply. Be sure all hot water restrictors installed for other equipment are working. (Check valves on sink faucets, dishwashers, etc.)
- If water pressure exceeds the maximum recommended pressure (90 psig), obtain a water pressure regulator from your Manitowoc distributor.
- Install a water shut-off valve at the dispenser.
- Insulate water lines to prevent condensation.

DRAIN CONNECTIONS

Follow these guidelines when installing drain lines to prevent drain water from backing up into the dispenser.



CAUTION

Plumbing must conform to state and local codes.

- The dispenser is equipped with a 1/2" F.P.T. (female pipe thread) fitting at the rear of the dispenser.
- The dispenser drain must be run separately to prevent water from other sources from entering machine.
- Drain lines must be vented to atmosphere.
- Drain lines must have a 1.5 inch (3.75 cm) drop per 40 inches (1 meter) of run, and must not create traps.
- The floor drain must be large enough to accommodate drainage from all drains.
- Insulate the drain line to prevent condensation.

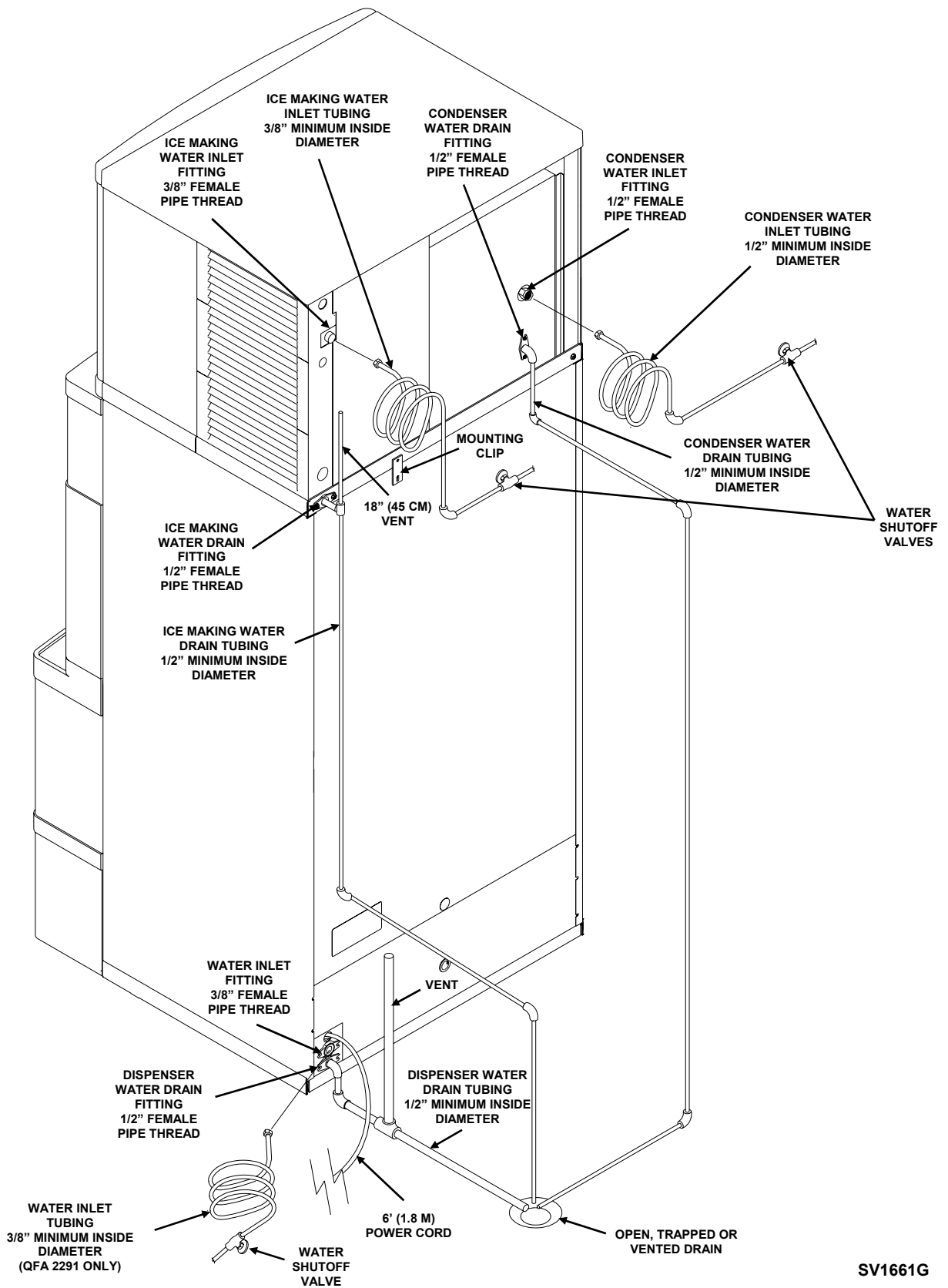

Water Service and Drain Connections

SV1661G

**Section 3
Dispenser Operation**

Method of Operation (All Models)

When ice is required, the customer or attendant presses the ice delivery push button switch. This action activates a relay, which is located in the control box enclosure. The relay energizes the dispenser motor.

The dispenser motor is direct-coupled to a right angle gearbox. This gearbox drives a toothed positive-displacement belt, the dispensing auger, and the agitating auger.

Auger	Revolutions per Minute
Dispensing Auger	35
Agitator Auger	17

Rate of Delivery

Model	Rate of Delivery*
Q290	0.50 - 1.3 oz/sec (15 - 38 g/sec)
Q310 Q330 Q340	0.85 - 3.7 oz/sec (24 - 105 g/sec)

*Depending on cube size and quantity of ice in bin.

 Warning

PERSONAL INJURY POTENTIAL

Do not operate equipment that has been, misused, abused, neglected, damaged, or altered/modified from that of original manufactured specifications.

Sequence of Operation

QFA-290 PUSHBUTTON OPERATED

ICE DELIVERY

Depressing the ice delivery push button allows power to flow through the switch to the solid state relay. The relay energizes and powers the windings of the dispenser motor. This motor drives a gearbox, which in turn drives a pulley. A toothed positive-displacement v-belt is attached to the drive pulley, a spring loaded tension pulley, and the agitator and dispenser pulleys. The turning of the augers causes the ice to ride to the top of the dispensing auger, where it will open a door and drop through the ice chute into the glass held beneath the outlet.

When sufficient ice has been dispensed, the push button is released and delivery stops.

WATER DELIVERY

Depressing the water delivery push button allows power to flow through the switch to the coil located on the water valve. The magnetic action of the solenoid coil lifts the plunger off its seat on the diaphragm. Water pressure forces the diaphragm open allowing water to flow through the tubing and out the water delivery spout.

When sufficient water has been dispensed into the glass, the push button is released and delivery stops.

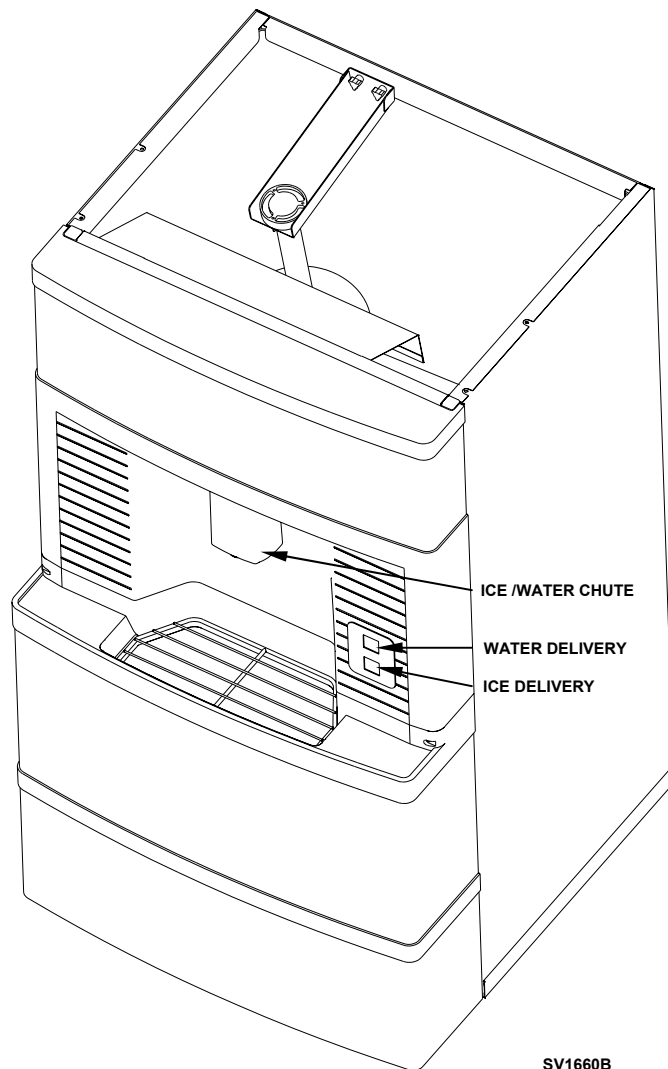

QPA-310 PUSH BUTTON OPERATED

ICE DELIVERY

Depressing the ice delivery push button allows power to flow through the switch to the solid state relay. The relay energizes and powers the windings of the dispenser motor. This motor drives a gearbox, which in turn drives a pulley. A toothed positive displacement v-belt is attached to the drive pulley, a spring loaded tension pulley, and the agitator and dispenser pulleys. The turning of the augers causes the ice to ride to the top of the dispensing auger, where it will open a door and drop through the ice chute into the bucket placed beneath the outlet.

When sufficient ice has been dispensed, the push button is released and delivery stops.

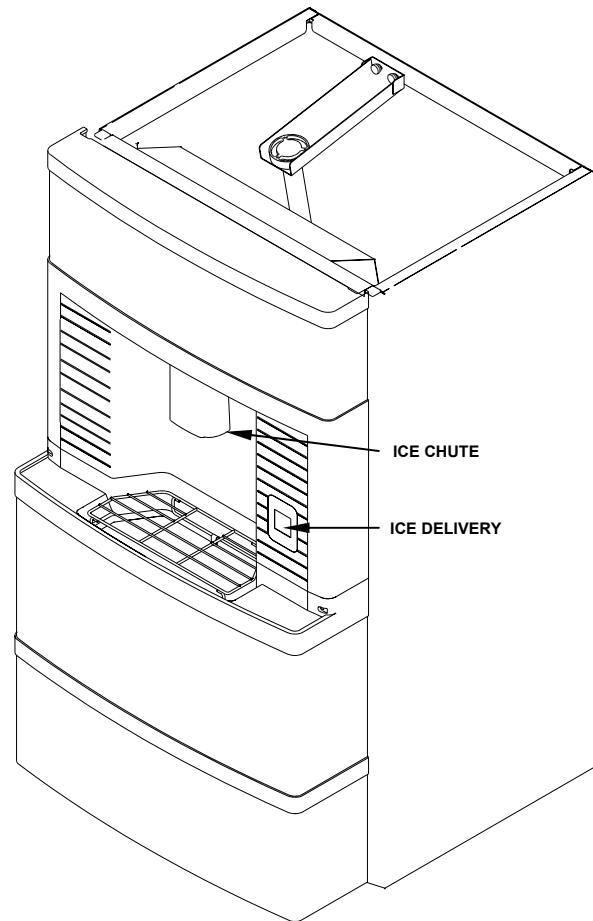

SV1246C

QCA-330 COIN OPERATED

Inserting a coin into the slot activates a micro switch on the coin mechanism. Power flows to the time delay relay, and closes the normally open relay contacts. The closed contacts supply power to the push button switch.

Depressing the ice delivery push button allows power to flow through the switch to the solid state relay. The relay energizes and powers the windings of the dispenser motor. This motor drives a gearbox, which in turn drives a pulley. A toothed positive displacement v-belt is attached to the drive pulley, a spring loaded tension pulley, and the agitator and dispenser pulleys. The turning of the augers causes the ice to ride to the top of the dispensing auger, where it will open a door and drop through the ice chute into the bucket placed beneath the outlet.

When sufficient ice has been dispensed, the push button is released, and delivery stops.

The dispenser will not dispense ice until another coin is inserted.

Time Delay Relay

The time delay relay can be adjusted from 1 second to 100 seconds. It ships from the factory set to 40 seconds. This setting covers the majority of applications. Settings of less than 40 seconds can lead to insufficient quantities of ice being dispensed if the level of ice in the dispenser is low.

Delivery of ice can be stopped two ways:

1. The vend push button is released.
2. The setting on the time delay relay has been exceeded.

Coin Removal

The coin mechanism accepts U.S. 25-cent coins only. Tokens are not available for the Q Series dispensers.

Removal of the front door is not required to access the coin box.

Insert the key into the cam lock and turn clockwise to open. The coin door assembly is hinged to swing downward.

Lift and pull forward on the cash box to remove and empty.

Re-install the cash box, engage cam lock, and remove key.

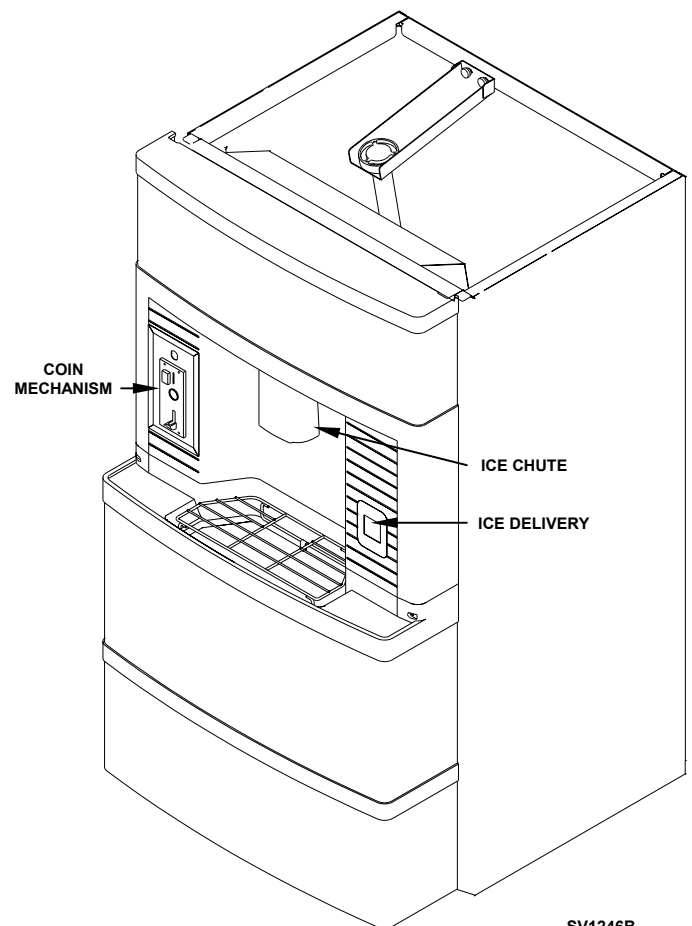

SV1246B

QRA-340 CARD OPERATED

ICE DELIVERY

Inserting the card into the slot closes the normally open contacts of the microswitch. The closed contacts supply power to the push button switch.

Depressing the ice delivery push button allows power to flow through the switch to the solid state relay. The relay energizes and powers the windings of the dispenser motor. This motor drives a gearbox, which in turn drives a pulley. A toothed positive displacement v-belt is attached to the drive pulley, a spring loaded tension pulley, and the agitator and dispenser pulleys. The turning of the augers causes the ice to ride to the top of the dispensing auger, where it will open a door and drop through the ice chute into the bucket placed beneath the outlet.

When sufficient ice has been dispensed, the push button is released, delivery stops and the card is removed.

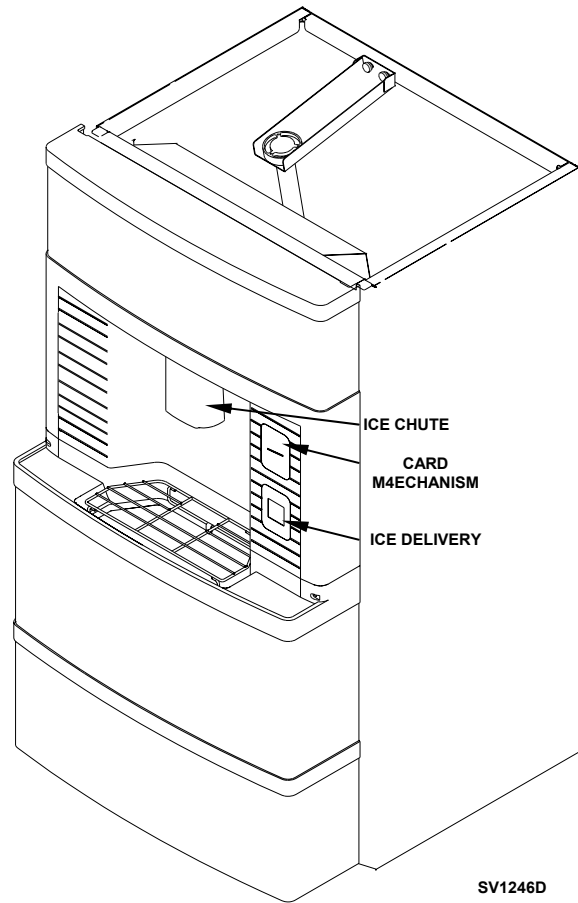

THIS PAGE INTENTIONALLY LEFT BLANK

Section 4 Maintenance

General

You are responsible for maintaining the dispenser in accordance with the instructions in this manual.

 **WARNING**

If you do not understand the procedures or the safety precautions that must be followed, call your local Manitowoc service representative to perform the maintenance procedures for you.

We recommend that you perform the following maintenance procedures every six months to ensure reliable, trouble-free operation.

Dispenser Inspection

- Check all water fittings and lines for leaks.
- Verify drains are unobstructed.

Exterior Cleaning

- Clean the area around the dispenser as often as necessary to maintain cleanliness and efficient operation.
- Sponge any dust and dirt off the outside of the dispenser with mild soap and water. Wipe dry with a clean, soft cloth.

Cleaning and Sanitizing

When cleaning or sanitizing the dispenser, pay close attention to the safety information below.

 **WARNING**

Before removing any parts, unplug or disconnect the electric power to the dispenser at the electric service switch box.

 **WARNING**

Do not mix Ice Machine Cleaner and Sanitizer solutions together. It is a violation of Federal law to use these solutions in a manner inconsistent with their labeling.

 **WARNING**

Wear rubber gloves and safety goggles (and/or face shield) when handling Ice Machine Cleaner or Sanitizer.

 **CAUTION**

Do not use metal scrapers or abrasives on the bin liner or plastic parts. The smooth surfaces will be damaged.

 **CAUTION**

Use only Manitowoc approved Ice Machine Cleaner (part number 94-0546-3) and Sanitizer (part number 94-0565-3). It is a violation of Federal law to use these solutions in a manner inconsistent with their labeling. Read and understand all labels printed on bottles before use.

CLEANING PROCEDURE

Ice machine cleaner is used to remove lime scale or other mineral deposits. It is not used to remove algae or slime. Refer to the “Sanitizing Procedure” for removal of algae and slime.



WARNING

Before beginning this procedure, unplug or disconnect the electric power to the dispenser at the electric service switch box.

1. Remove all ice from the dispenser.
2. Remove the front door assembly. (Refer to “Door Removal” on page 6-1.)
3. Remove the thumbscrews securing the top and sides of the access panel. Remove the panel by lifting up and forward.
4. Remove the three thumbscrews securing the delivery auger bearing. Remove the delivery auger by lifting up.
5. Remove the two thumbscrews securing the agitator auger bearing. Remove the agitator auger by lifting up.
6. Remove the false bottom by lifting the left or right side and tipping it up on edge.
7. Clean the inside of the bin, augers, false bottom and inside of the front door with a solution of 3 oz. (100 ml) Manitowoc cleaner per 1 gallon (4 liters) of water.
8. Rinse all parts thoroughly with clean water.
9. To sanitize the dispenser, refer to “Sanitizing Procedure.”
10. Reassemble by reversing steps 1 - 6.

SANITIZING PROCEDURE

Use sanitizer to remove algae or slime. Do not use it to remove lime scale or other mineral deposits.



WARNING

Before removing any parts, unplug or disconnect the electric power to the dispenser at the electric service switch box.

1. Follow steps 1 - 8 under “Cleaning Procedure.”
2. Sanitize the ice bin with a solution of 1 oz. (30 ml) of sanitizer with up to 4 gal. (15 liters) of water.
3. Allow parts to air dry.
4. Reassemble by reversing steps 1 - 7 under “Cleaning Procedure.”

Removal of Parts

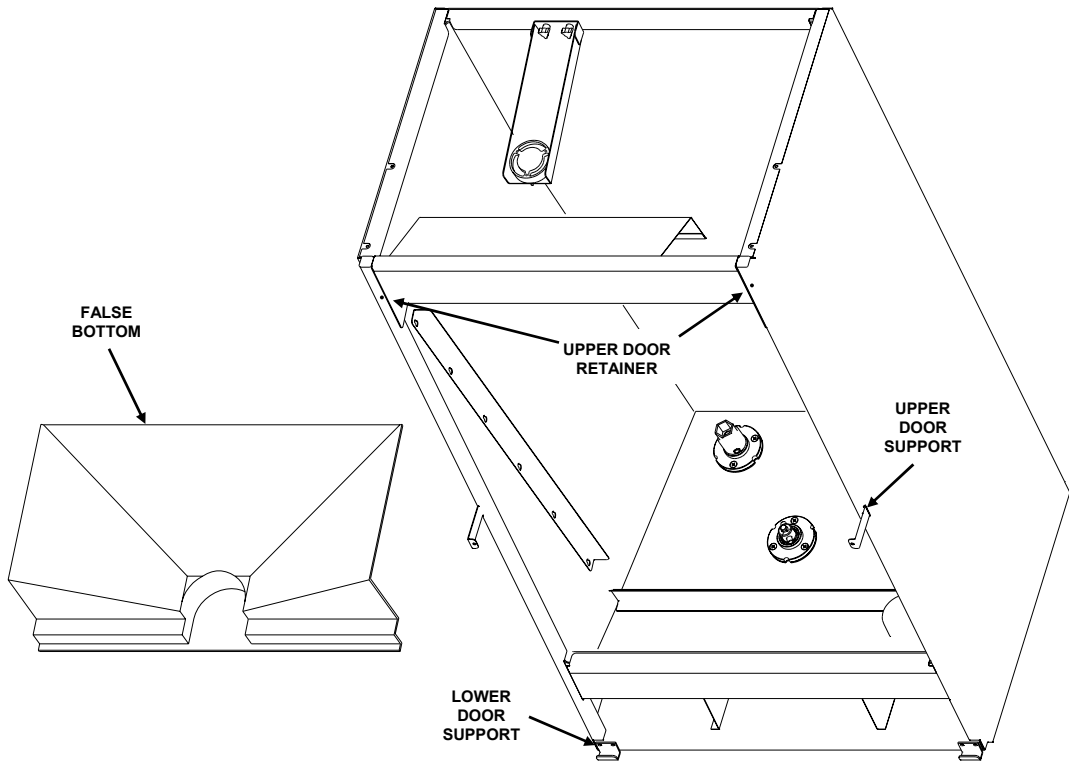
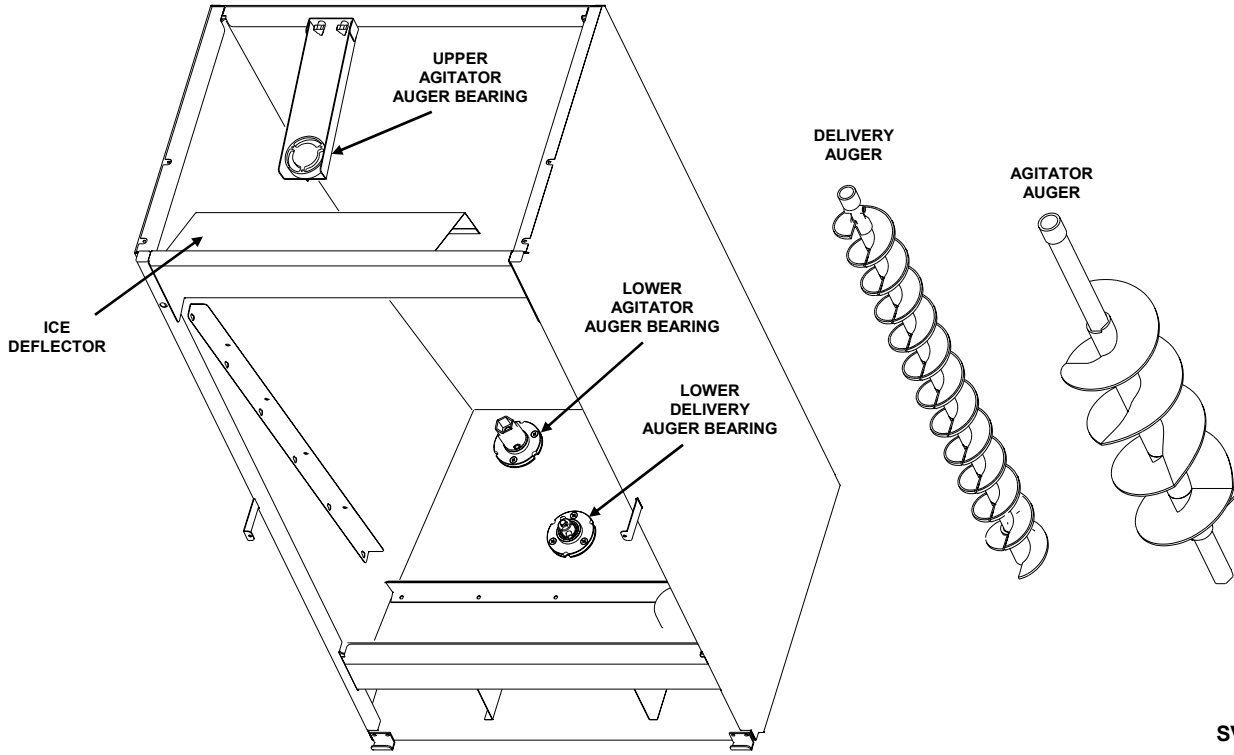

Overview of Parts Removal

Removal from Service/Winterization

GENERAL

Special precautions must be taken if the dispenser is to be removed from service for an extended period of time or exposed to ambient temperatures of 32°F (0°C) or below.



CAUTION

If water is allowed to remain in the dispenser in freezing temperatures, severe damage to some components could result. Damage of this nature is not covered by the warranty.

PROCEDURE

1. Disconnect the electric power at the circuit breaker or the electric service switch.
2. Turn off the water supply.
3. Disconnect and drain the incoming water line at the rear of the dispenser.
4. Blow compressed air in both the incoming water and the drain openings in the bottom of the dispenser until no more water comes out of the water valve or the drain.
5. Make sure water is not trapped in any of the water lines or drain lines.

Section 5 Before Calling for Service

Checklist

If a problem arises during operation of your dispenser, follow the checklist below before calling for service.

Problem	Possible Cause	To Correct
Dispenser will not dispense ice.	No electrical power to dispenser.	Check fuse/breaker. Check power cord.
	Bin empty.	Allow ice machine time to replenish ice.
	Ice jammed in ice chute opening.	Clear ice chute opening.
Drive motor operates but auger doesn't turn.	Drive belt broken or loose. (A loose belt causes a ratcheting noise.)	Tighten tensioner or replace belt.
	Auger not properly seated on lower bearing.	Remove ice from dispenser and correctly reposition shaft.
Water on floor.	Drain obstructed.	Clear drain.
	Dispenser not level.	Refer to "Leveling the Dispenser" on page 2-3.
	Drain installed incorrectly.	Refer to "Drain Connections" on page 2-5.

THIS PAGE INTENTIONALLY LEFT BLANK

Section 6 Service

Door Removal

⚠ WARNING

Before removing any parts, unplug or disconnect the electric power to the dispenser at the electric service switch box.

1. Shut off the water if applicable.
2. Loosen the two access screws located on the sides of the front panel, above the catch basin.
3. Lift up and pull forward on the top of the door until the upper door retainers disengage.
4. Pivot the door 90°. This should provide adequate access. If complete door removal is desired, perform steps 5-8.
5. Disconnect the water supply line at the water delivery spout quick disconnect if applicable.
6. Disconnect the push button switch wiring by removing the female push-on terminals at the switch.
7. Remove the door.

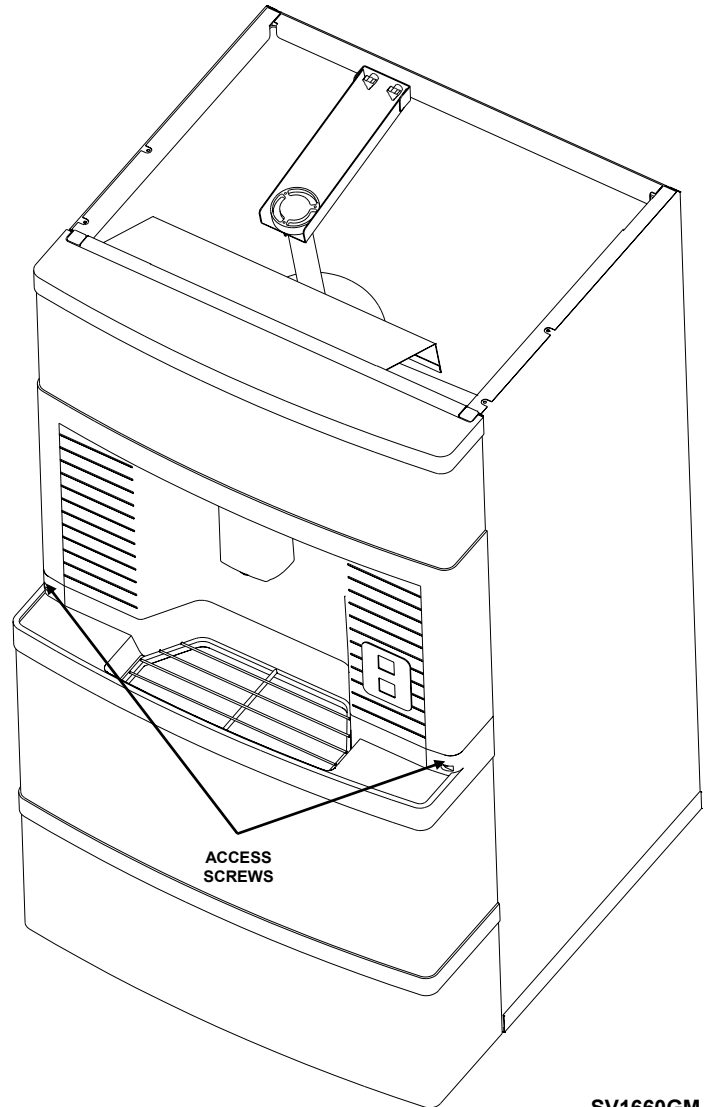

SV1660GM

Door Removal

Delivery Auger and Agitator Auger Removal

WARNING
 Before removing any parts, unplug or disconnect the electric power to the dispenser at the electric service switch box.

1. Empty the ice from the dispenser.
2. Unplug the power cord from the wall outlet.
3. Remove the front panel from the ice machine.
4. Move the ice machine's ICE/OFF/CLEAN switch to the OFF position.
5. Remove the front door from the dispenser. (See "Door Removal" on page 6-1.)
6. Remove the thumbscrews from the front of the bin liner. Remove the bin liner.
7. Remove the ice deflector and upper bearing supports for the delivery auger and agitator auger by removing the thumbscrews, which fasten the supports to the dispenser.
8. Lift the two augers vertically off the drive shafts and out of the dispenser.
9. Remove the false bottom.
10. If lower bearing removal is desired, see "Lower Bearing Assembly" on page 6-4.

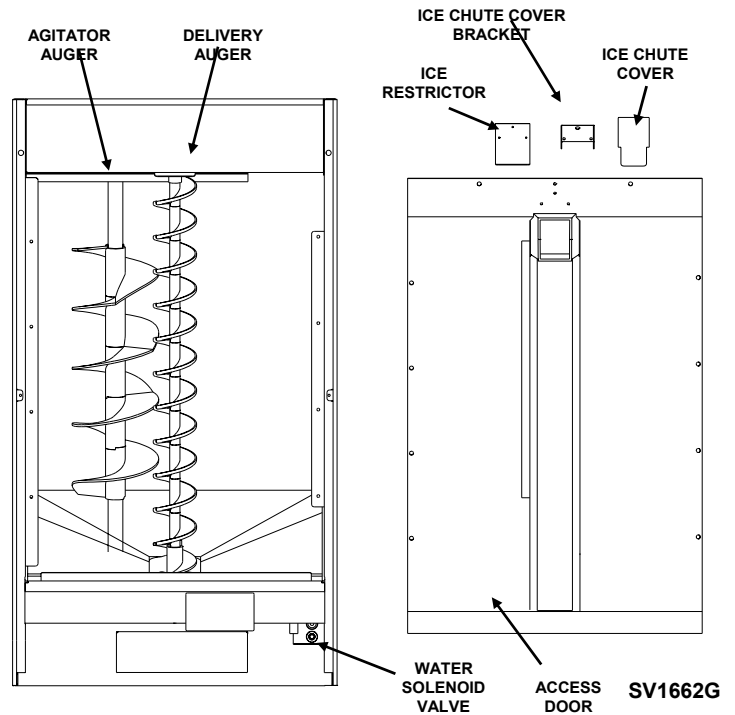

Auger Removal

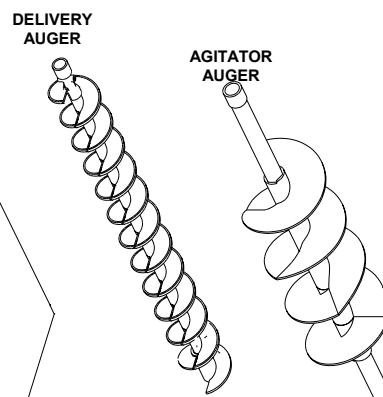
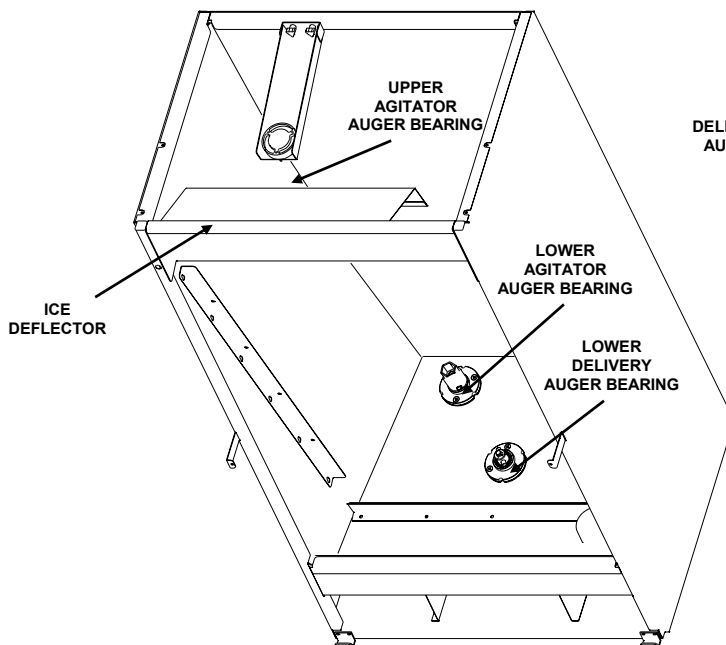

SV1664G

Auger Removal

Delivery Auger

DISASSEMBLY

1. Remove the clevis pin from the upper bearing coupling and auger shaft.
2. Remove the upper bearing coupling and auger flights by sliding them up the shaft.

ASSEMBLY

1. Slide the lower bearing coupling down the auger shaft. Align and fully engage the bearing with the hex on the shaft.
2. Add flights to form a spiral.
3. Install the upper bearing coupling and clevis pin.

Agitator Auger

DISASSEMBLY

1. Remove the upper bearing coupling by pulling upward in a rocking motion.
2. Remove the flights by sliding them up the shaft.

ASSEMBLY

1. Slide an auger flight down the shaft until it fully engages the shaft pin.
2. Add flights to form a spiral.
3. Install the upper bearing coupling.

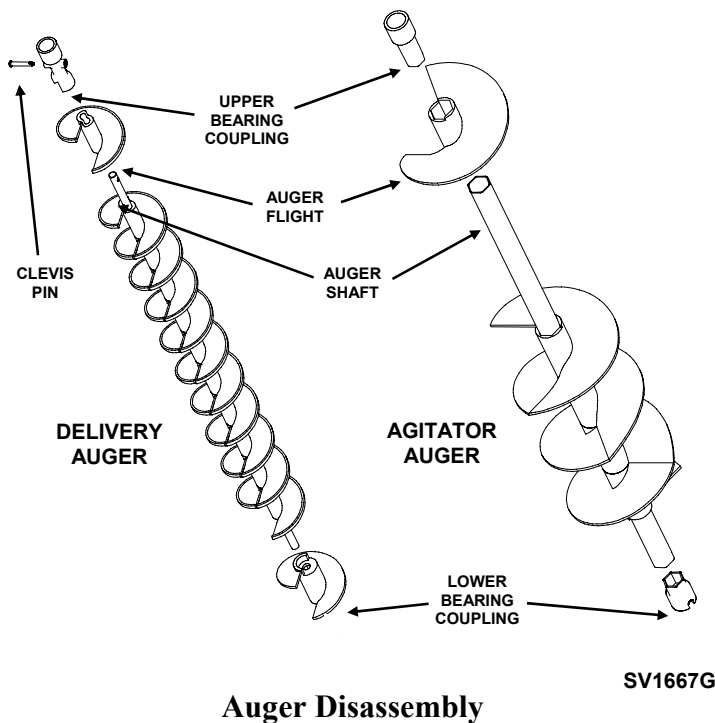

Belt Tightening and Replacement

WARNING
Unplug the power cord from the wall outlet before tightening or replacing the belt.

The belt is held snug by a tension spring. This is accessible either from the rear by removing the rear panel, or from the front by opening the front door. (For increased access, remove the electrical control box fasteners and move the box aside.)

To adjust or replace the belt:

1. Cut the plastic wire tie and loosen the bolt securing the spring tension bracket. Pivot the bracket toward the front of the dispenser to release the spring tension.
2. If replacing, remove the old belt. Install new belt.
3. Assure that all slack in the belt is taken up between the auger and the agitator pulley.
4. Make sure the belt tensioner mounting bracket slides freely. Grease the dispenser base if necessary.
5. Move the spring tension bracket back into position and tighten the bolt.
6. Install a new plastic wire tie.

Important
Pulley alignment can be adjusted by moving the gearbox angle bracket located underneath the gearbox. Make sure it is positioned correctly.

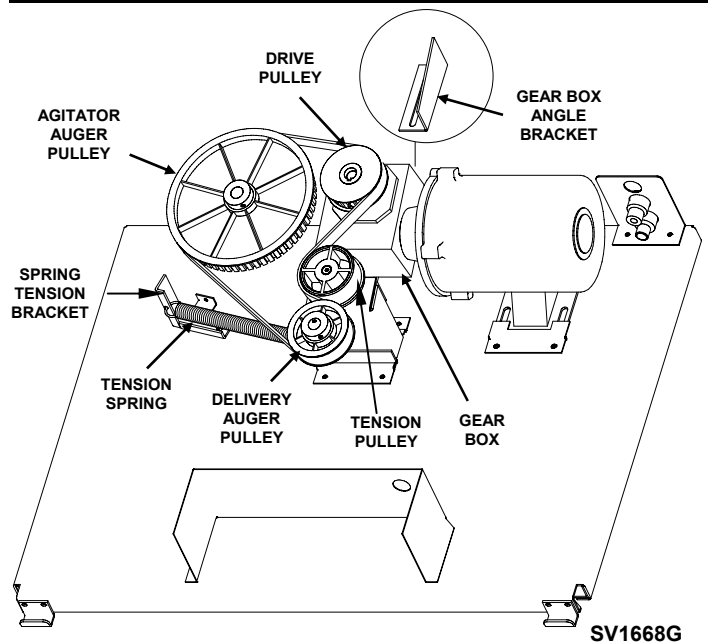

Belt Tightening and Replacement

Lower Bearing Assembly

⚠ WARNING
 Before removing any parts, unplug or disconnect the electric power to the dispenser at the electric service switch box.

⚠ CAUTION
 Protect the water seal from damage during disassembly and reassembly.

REMOVAL

1. Remove all ice from the bin.
2. Remove the auger assembly. (Refer to page 6-2.)
3. Remove the bolt securing the drive pin (located on top of the bearing drive shaft) and remove the drive pin
4. Remove the belt. (Refer to page 6-3.)
5. Remove the lower bearing drive pin, pulley, and plastic drive coupling on the agitator drive shaft.
6. Remove the three bolts holding the upper bearing housing assembly to the lower bearing housing assembly.

NOTE: The bolt heads have been filled with silicone sealant. Clean it out to ensure good wrench engagement. (Use a #27 Torx driver.)

7. Remove the three bolts from the inside of the bin to remove the upper bearing assembly.
8. Remove the lower bearing housing assembly from the gear/motor compartment side.

INSTALLATION

1. Coat the sealing face of the upper bearing housing with silicone sealant to ensure a watertight seal between the housing and the bin liner.
2. Position the bearing assembly in the bin bottom.

NOTE: Seal under the bolt heads with silicone sealant to ensure a watertight seal.

3. From inside the bin, insert the three mounting bolts through the upper bearing housing.
4. Install the lower bearing housing and shaft from the gear/motor compartment side.
5. Start all three bolts and tighten evenly to ensure proper alignment. Tighten the bolts to 95 in-lbs. (110 kg-cm).

6. Install the pulley and insert the pin into the lower bearing drive shaft.
7. Insert the bolt and washer.
8. Replace the plastic drive coupling on the agitator drive shaft.
9. Install the belt. (Refer to page 6-3.)
10. Install drive pin in bearing shaft and lock in place with bolt removed in step 3.
11. Install the auger assembly. (Refer to page 6-2.)

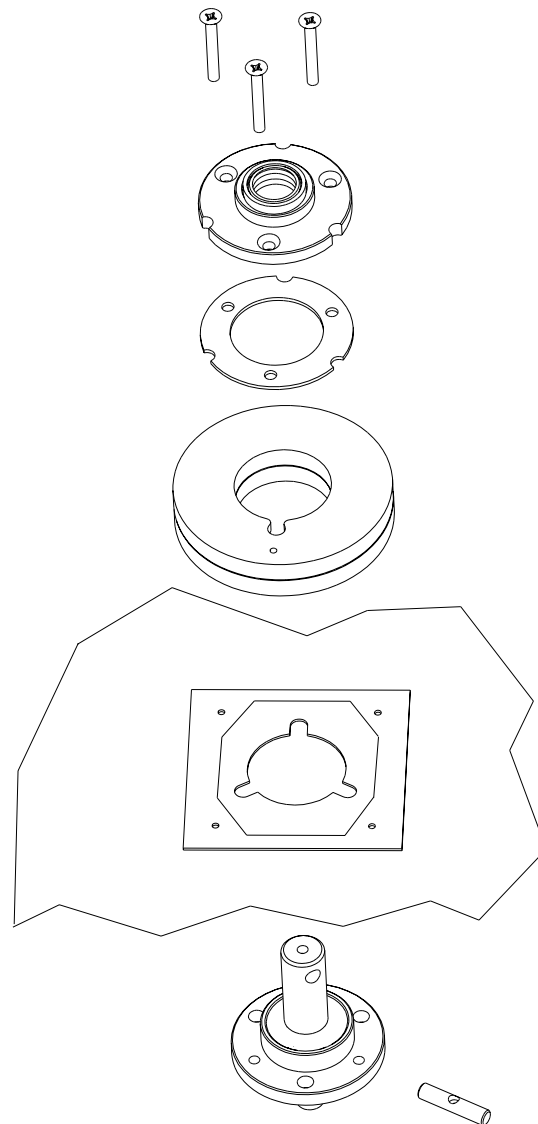

SV1665G

Lower Bearing Assembly

Upper Bearing Assembly Removal

**WARNING**

Before removing any parts, unplug or disconnect the electric power to the dispenser at the electric service switch box.

1. Remove all ice from the bin.
2. Remove the auger assembly. (Refer to page 6-2.)
3. Remove three thumbscrews from the agitator auger bearing to remove the bearing.
4. Remove three thumbscrews from the delivery auger bearing to remove the bearing.

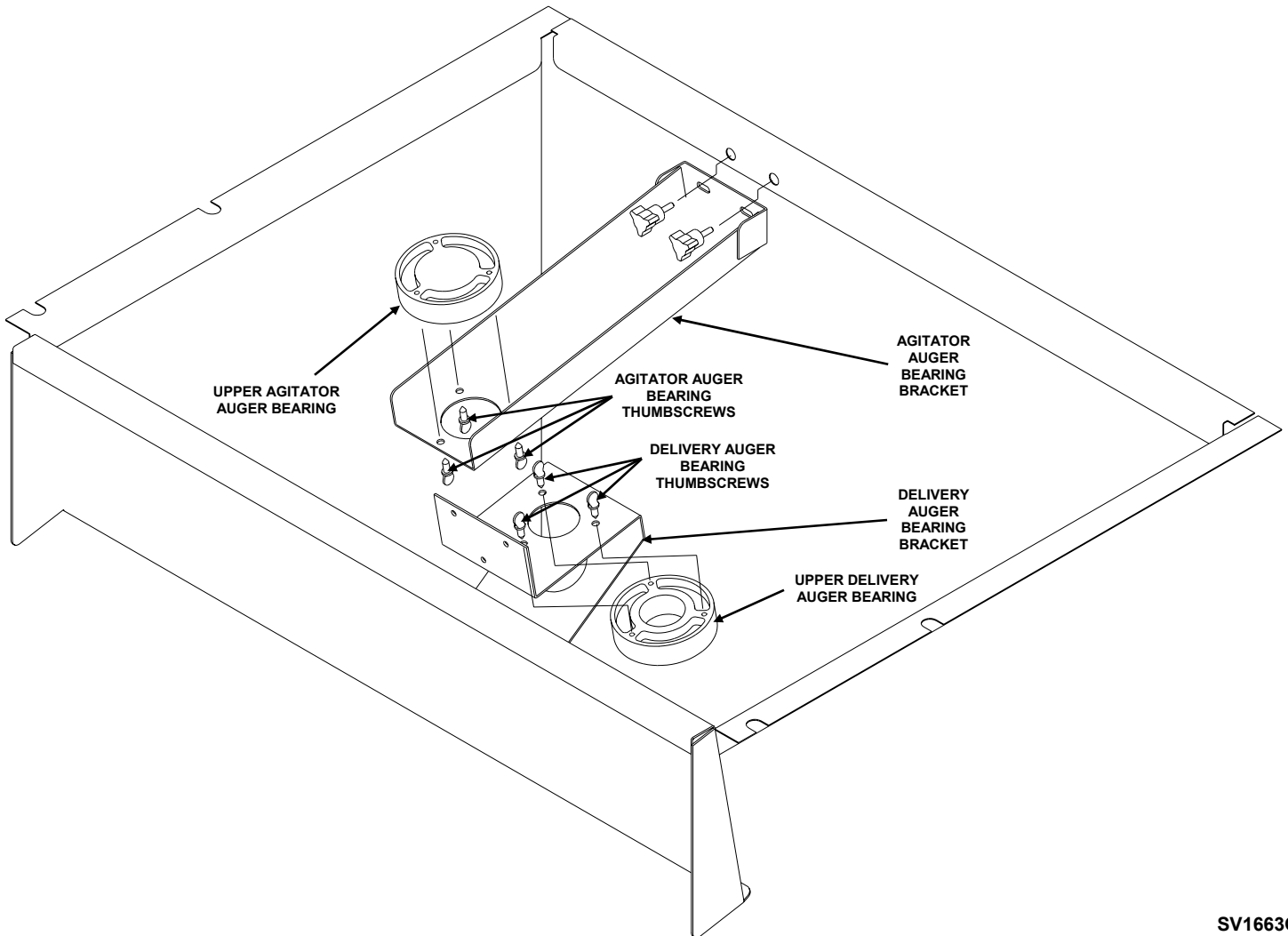

SV1663G

Upper Bearing Assembly

Wiring Diagrams

QPA-310 PUSH BUTTON OPERATED

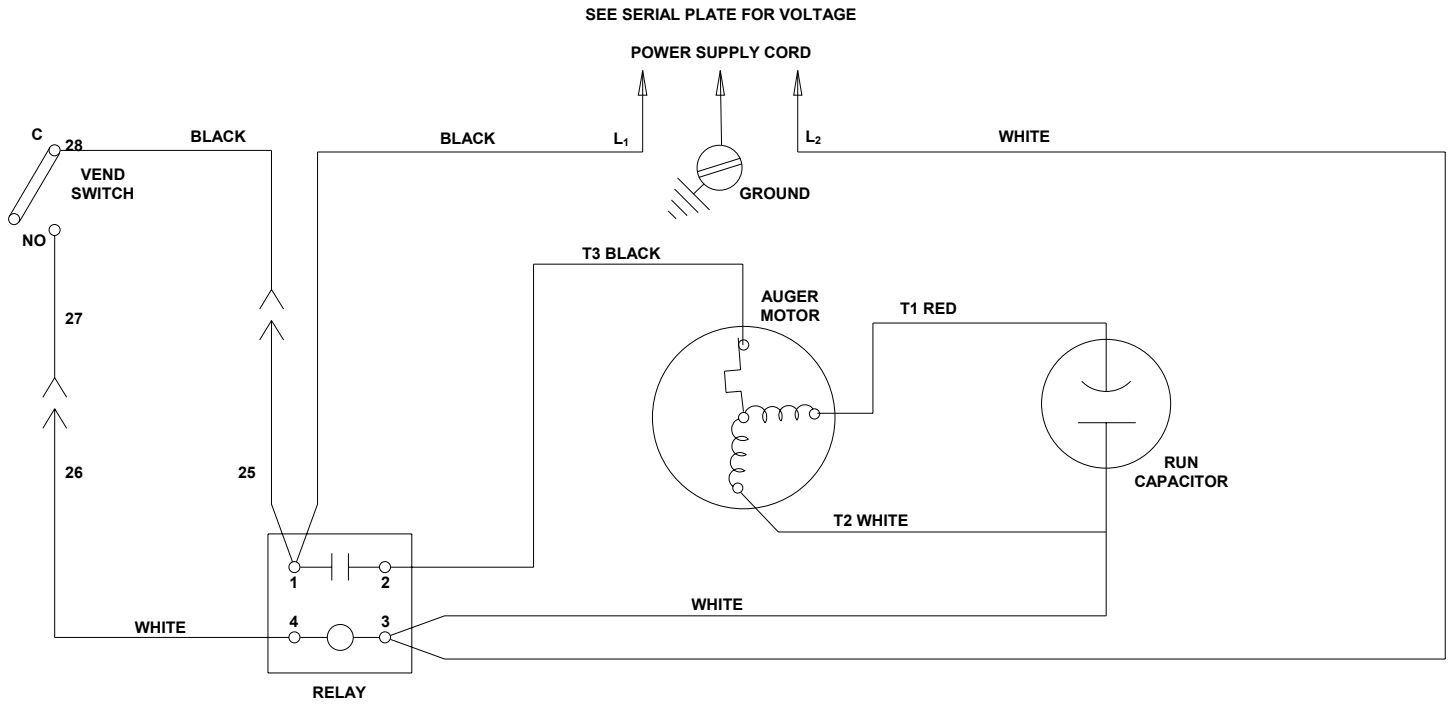

QRA-340 ROOM CARD OPERATED

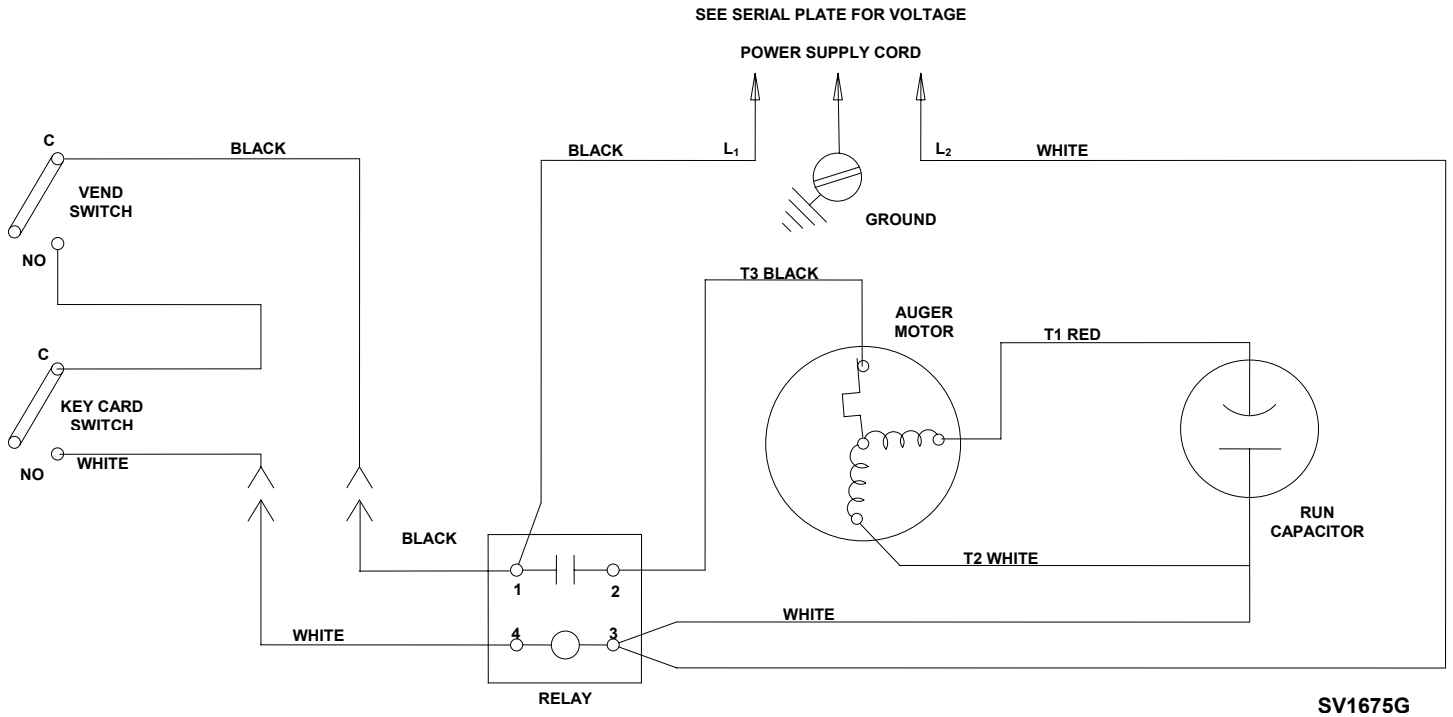

Wiring Diagrams

QFA-291 GLASS FILL OPERATED

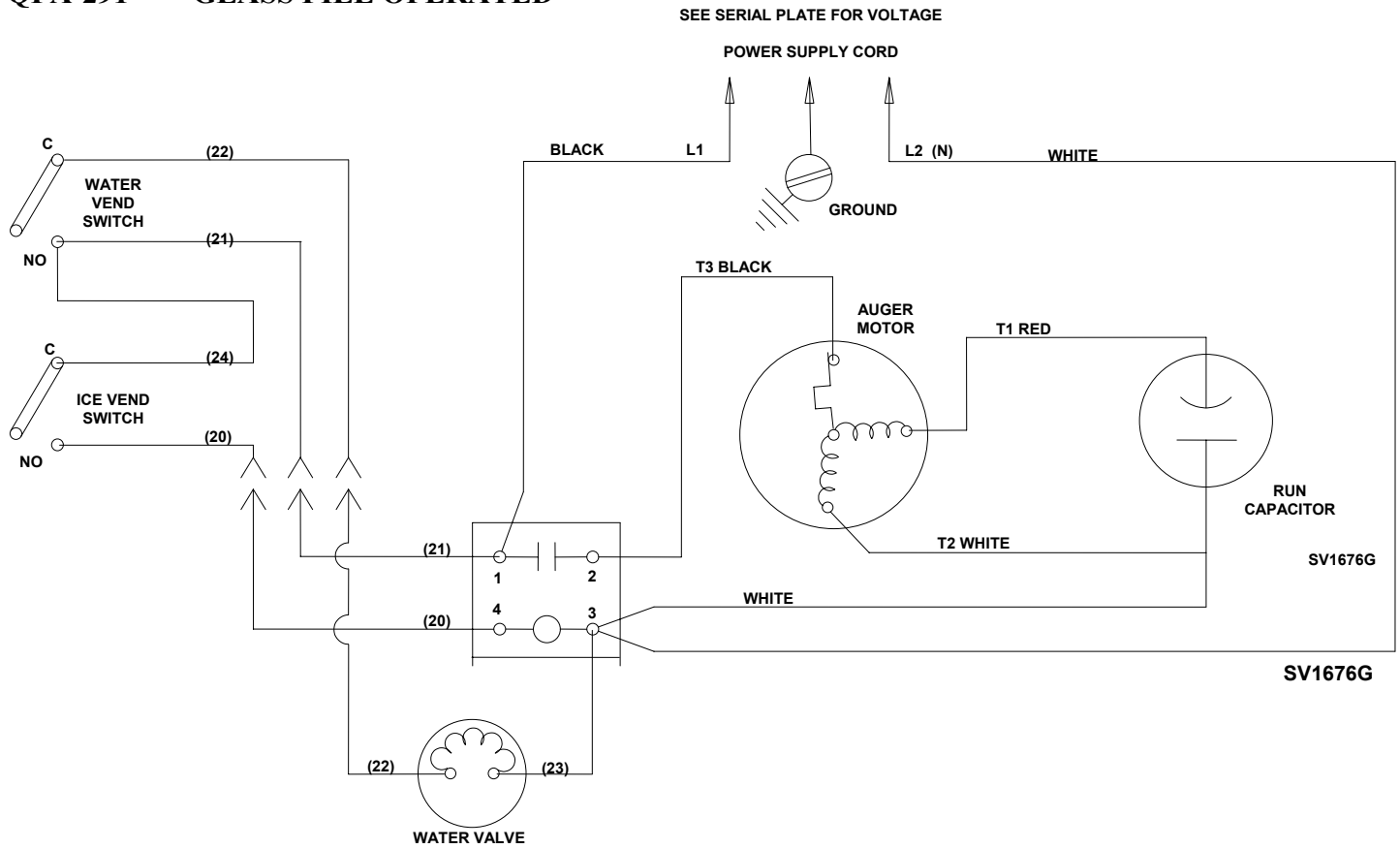

QCA-330 COIN OPERATED

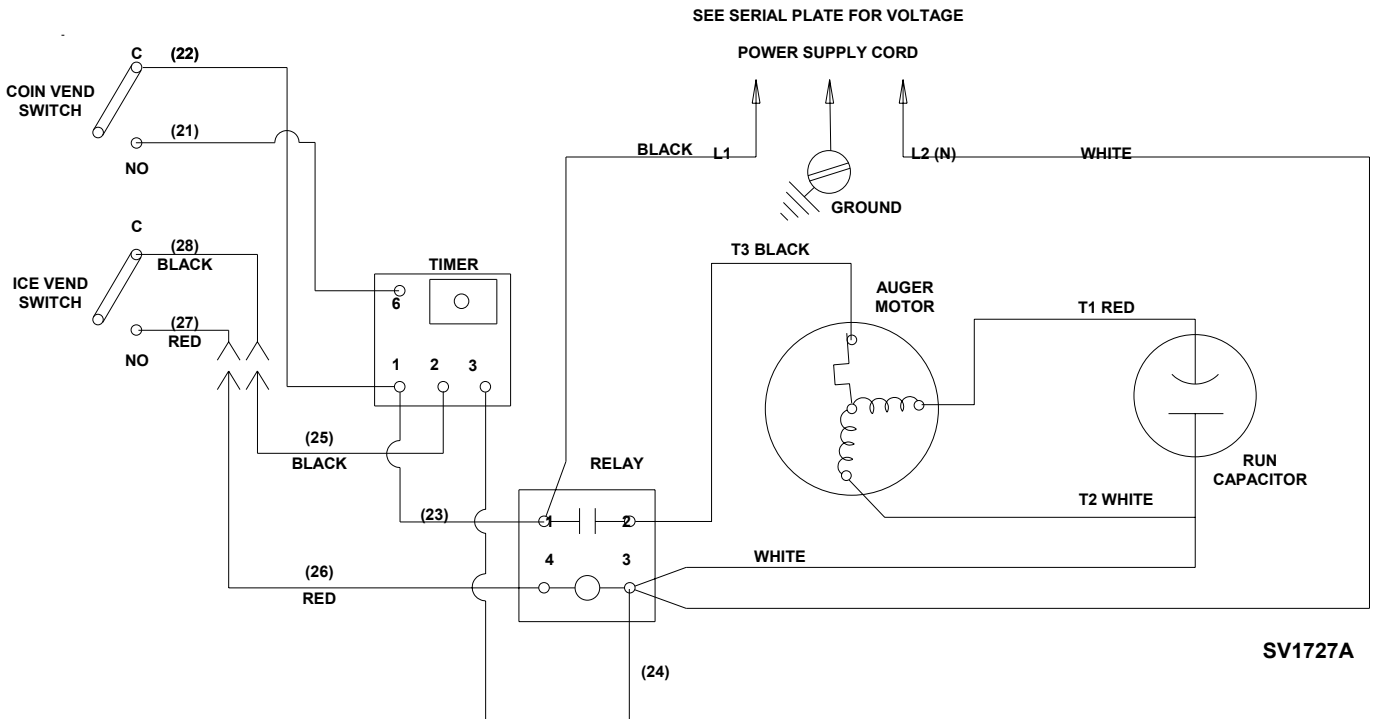

We reserve the right to make product improvements at any time.

Specifications and design are subject to change without notice.

MANITOWOC ICE, INC.

2110 South 26th Street P.O. Box 1720

Manitowoc, WI 54221-1720

Phone: (920) 682-0161

Service Fax: (920) 683-7585

Web Site: <http://www.manitowocice.com>

©1998 Manitowoc Ice, Inc.

Litho in USA