



**Manitowoc<sup>®</sup>**

---

# ICE MACHINES

## Q-Model Service Manual



## Safety Notices

As you work on a Q-Series Ice Machine, be sure to pay close attention to the safety notices in this manual. Disregarding the notices may lead to serious injury and/or damage to the ice machine.

Throughout this manual, you will see the following types of safety notices:

### **Warning**

#### **PERSONAL INJURY POTENTIAL**

Do not operate equipment that has been misused, abused, neglected, damaged, or altered/modified from that of original manufactured specifications.

### **Warning**

Text in a Warning box alerts you to a potential personal injury situation. Be sure to read the Warning statement before proceeding, and work carefully.

### **Caution**

Text in a Caution box alerts you to a situation in which you could damage the ice machine. Be sure to read the Caution statement before proceeding, and work carefully.

## Procedural Notices

As you work on a Q-Series Ice Machine, be sure to read the procedural notices in this manual. These notices supply helpful information which may assist you as you work.

Throughout this manual, you will see the following types of procedural notices:

### **Important**

Text in an Important box provides you with information that may help you perform a procedure more efficiently. Disregarding this information will not cause damage or injury, but it may slow you down as you work.

**NOTE:** Text set off as a Note provides you with simple, but useful, extra information about the procedure you are performing.

We reserve the right to make product improvements at any time. Specifications and design are subject to change without notice.

# Table of Contents

---

## Section 1

### General Information

|   |     |
|---|-----|
| <b>Model Numbers</b> .....                | 1-1 |
| <b>How to Read a Model Number</b> .....   | 1-1 |
| <b>Ice Cube Sizes</b> .....               | 1-1 |
| <b>Model/Serial Number Location</b> ..... | 1-2 |
| <b>Warranty Coverage</b> .....            | 1-3 |
| General .....                             | 1-3 |
| Parts .....                               | 1-3 |
| Labor .....                               | 1-3 |
| Exclusions .....                          | 1-3 |
| Authorized Warranty Service .....         | 1-3 |

## Section 2

### Installation Instructions

|  |     |
|--|-----|
| <b>General</b> .....   | 2-1 |
| <b>Ice Machine Dimensions</b> .....                            | 2-1 |
| Q320/Q370/Q420 Ice Machines .....                              | 2-1 |
| Q200 – Q1000 Ice Machines .....                                | 2-2 |
| Q1300/Q1600/Q1800 Ice Machines .....                           | 2-2 |
| Q1300/Q1600/Q1800 Ice Machines (Cont.) .....                   | 2-3 |
| <b>Ice Storage Bin Dimensions</b> .....                        | 2-3 |
| S170/S400/S570 Ice Storage Bins .....                          | 2-3 |
| S320/S420 Ice Storage Bins .....                               | 2-3 |
| S970 Ice Storage Bins .....                                    | 2-4 |
| <b>Remote Condenser Dimensions</b> .....                       | 2-4 |
| JC0495/JC0895/JC1095/JC1395 .....                              | 2-4 |
| JC1895 .....   | 2-4 |
| <b>Location of Ice Machine</b> .....                           | 2-5 |
| <b>Stacking Two Ice Machines on a Single Storage Bin</b> ..... | 2-5 |
| <b>Ice Machine Heat of Rejection</b> .....                     | 2-5 |
| <b>Leveling the Ice Storage Bin</b> .....                      | 2-6 |
| <b>Air-Cooled Baffle</b> .....                                 | 2-6 |
| <b>Electrical Service</b> .....                                | 2-7 |
| General .....  | 2-7 |
| Voltage .....  | 2-7 |
| Fuse/Circuit Breaker .....                                     | 2-7 |
| Minimum Circuit Ampacity .....                                 | 2-7 |
| <b>Self-Contained Electrical Wiring Connections</b> .....      | 2-9 |
| Self Contained Ice Machine<br>115/1/60 or 208-230/1/60 .....   | 2-9 |
| Self Contained Ice Machine<br>208-230/3/60 .....               | 2-9 |
| Self Contained Ice Machine<br>230/1/50 .....                   | 2-9 |
| <b>For United Kingdom Only</b> .....                           | 2-9 |

## Table of Contents (continued)

---

|   |             |
|---|-------------|
| <b>Remote Electrical Wiring Connections</b> .....                             | <b>2-10</b> |
| Remote Ice Machine  |             |
| With Single Circuit Model Condenser   |             |
| 115/1/60 or 208-230/1/60 .....  | <b>2-10</b> |
| Remote Ice Machine  |             |
| With Single Circuit Model Condenser   |             |
| 208-230/3/60 or 380-415/3/50 .....  | <b>2-10</b> |
| Remote Ice Machine  |             |
| With Single Circuit Model Condenser   |             |
| 230/1/50 .....  | <b>2-10</b> |
| <b>Water Supply and Drain Requirements</b> .....                              | <b>2-11</b> |
| Water Supply .....  | <b>2-11</b> |
| Water Inlet Lines .....   | <b>2-11</b> |
| Drain Connections .....   | <b>2-11</b> |
| <b>Cooling Tower Applications</b>   |             |
| <b>(Water-Cooled Models)</b> .....  | <b>2-11</b> |
| Water Supply and Drain Line Sizing/Connections .....                          | <b>2-12</b> |
| <b>Remote Condenser/Line Set Installation</b> .....                           | <b>2-13</b> |
| Remote Ice Machines   |             |
| Refrigerant Charge .....  | <b>2-13</b> |
| General .....   | <b>2-14</b> |
| Guidelines for Routing Line Sets .....  | <b>2-14</b> |
| Calculating Remote Condenser Installation Distances .....                     | <b>2-15</b> |
| Lengthening or Reducing Line Set Lengths .....                                | <b>2-16</b> |
| Connecting A Line Set .....   | <b>2-16</b> |
| Remote Receiver Service Valve .....   | <b>2-16</b> |
| <b>Remote Ice Machine Usage with Non-Manitowoc Multi-Circuit Condensers</b> . | <b>2-17</b> |
| Warranty .....  | <b>2-17</b> |
| Head Pressure Control Valve .....   | <b>2-17</b> |
| Fan Motor .....   | <b>2-17</b> |
| Internal Condenser Volume .....   | <b>2-17</b> |
| Condenser DT .....  | <b>2-17</b> |
| Refrigerant Charge .....  | <b>2-17</b> |
| Quick Connect Fittings .....  | <b>2-17</b> |
| Non-Manitowoc Multi-Circuit Condenser Sizing Chart .....                      | <b>2-18</b> |
| <b>Installation Check List</b> .....  | <b>2-19</b> |
| <b>Additional Checks for Remote Models</b> .....                              | <b>2-19</b> |

## Table of Contents (continued)

---

### Section 3

#### Ice Machine Operation

|  |     |
|--|-----|
| <b>Component Identification</b> .....                                    | 3-1 |
| <b>Self-Contained Air- and Water-Cooled</b>                              |     |
| <b>Q200/Q280/Q320/Q370/Q420/Q450/Q600/Q800/Q1000/Q1300/Q1600/Q1800</b> . | 3-2 |
| Initial Start-Up or Start-Up After Automatic Shut-Off .....              | 3-2 |
| Freeze Sequence .....  | 3-2 |
| Harvest Sequence .....   | 3-3 |
| Automatic Shut-Off .....   | 3-3 |
| <b>Remote</b>  |     |
| <b>Q450/Q600/Q800/Q1000/Q1300/Q1600/Q1800</b> .....                      | 3-4 |
| Initial Start-Up or Start-Up After Automatic Shut-Off .....              | 3-4 |
| Freeze Sequence .....  | 3-4 |
| Harvest Sequence .....   | 3-5 |
| Automatic Shut-Off .....   | 3-5 |
| <b>Operational Checks</b> .....  | 3-6 |
| General .....  | 3-6 |
| Water Level .....  | 3-6 |
| Ice Thickness Check .....  | 3-6 |
| Harvest Sequence Water Purge .....                                       | 3-7 |

### Section 4

#### Maintenance

|   |      |
|---|------|
| <b>General</b> .....                                    | 4-1  |
| <b>Interior Cleaning and Sanitizing</b> .....           | 4-1  |
| General .....   | 4-1  |
| Cleaning & Sanitizing Procedure .....                   | 4-1  |
| <b>Ice Machine Inspection</b> .....                     | 4-8  |
| <b>Exterior Cleaning</b> .....                          | 4-8  |
| <b>Cleaning the Condenser</b> .....                     | 4-8  |
| General .....   | 4-8  |
| Water-Cooled Condenser and Water Regulating Valve ..... | 4-9  |
| <b>Removal from Service/Winterization</b> .....         | 4-10 |
| General .....   | 4-10 |
| Self-Contained Air-Cooled Ice Machines .....            | 4-10 |
| Water-Cooled Ice Machines .....                         | 4-10 |
| Remote Ice Machines .....                               | 4-10 |

### Section 5

#### Water System Ice Making Sequence of Operation

|   |     |
|---|-----|
| Initial Start-Up or Start-Up After Automatic Shut-Off ..... | 5-1 |
| Freeze Cycle .....  | 5-1 |
| Water Inlet Valve Safety Shut-Off .....                     | 5-1 |
| Harvest Cycle .....   | 5-2 |
| Automatic Shut-Off .....                                    | 5-2 |

## Table of Contents (continued)

### Section 6 Electrical System

|  |             |
|--|-------------|
| <b>Energized Parts Charts</b> .....  | <b>6-1</b>  |
| Self-Contained Air- And Water-Cooled Models .....                                    | 6-1         |
| Remote Models .....  | 6-2         |
| <b>Wiring Diagram Sequence of Operation</b> .....                                    | <b>6-3</b>  |
| Self-Contained Models .....  | 6-3         |
| Remote Models .....  | 6-10        |
| <b>Wiring Diagrams</b> .....   | <b>6-17</b> |
| Wiring Diagram Legend .....  | 6-17        |
| Q200/Q280/Q320 - Self Contained - 1 Phase With Terminal Board .....                  | 6-18        |
| Q280/Q370 - Self Contained - 1 Phase Without Terminal Board .....                    | 6-19        |
| Q320 - Self Contained - 1 Phase Without Terminal Board .....                         | 6-20        |
| Q420/Q450/Q600/Q800/Q1000 - Self Contained -<br>1 Phase With Terminal Board .....    | 6-21        |
| Q420/Q450/Q600/Q800/Q1000 - Self Contained -<br>1 Phase Without Terminal Board ..... | 6-22        |
| Q800/Q1000 - Self Contained - 3 Phase With Terminal Board .....                      | 6-23        |
| Q800/Q1000 - Self Contained - 3 Phase Without Terminal Board .....                   | 6-24        |
| Q1300/Q1800 - Self Contained - 1 Phase With Terminal Board .....                     | 6-25        |
| Q1300/Q1600/Q1800 - Self Contained - 1 Phase Without Terminal Board .                | 6-26        |
| Q1300/Q1800 - Self Contained - 3 Phase With Terminal Board .....                     | 6-27        |
| Q1300/Q1600/Q1800 - Self Contained - 3 Phase Without Terminal Board .                | 6-28        |
| Q450/Q600/Q800/Q1000 - Remote - 1 Phase With Terminal Board .....                    | 6-29        |
| Q450/Q600/Q800/Q1000 - Remote - 1 Phase Without Terminal Board ....                  | 6-30        |
| Q800/Q1000 -Remote - 3 Phase With Terminal Board .....                               | 6-31        |
| Q800/Q1000 -Remote - 3 Phase Without Terminal Board .....                            | 6-32        |
| Q1300/Q1800 - Remote - 1 Phase With Terminal Board .....                             | 6-33        |
| Q1300/Q1600/Q1800 - Remote - 1 Phase Without Terminal Board .....                    | 6-34        |
| Q1300/Q1800 - Remote - 3 Phase With Terminal Board .....                             | 6-35        |
| Q1300/Q1600/Q1800 - Remote - 3 Phase Without Terminal Board .....                    | 6-36        |
| <b>Component Specifications and Diagnostics</b> .....                                | <b>6-38</b> |
| Main Fuse .....  | 6-38        |
| Bin Switch .....   | 6-38        |
| Compressor Electrical Diagnostics .....  | 6-40        |
| PTCR Diagnostics .....   | 6-41        |
| ICE/OFF/CLEAN Toggle Switch .....  | 6-44        |
| Control Board Relays .....   | 6-44        |
| Electronic Control Board .....   | 6-45        |
| <b>Ice Thickness Probe (Harvest Initiation)</b> .....                                | <b>6-47</b> |
| How The Probe Works .....  | 6-47        |
| Harvest/Safety Limit Light .....   | 6-47        |
| Freeze Time Lock-In Feature .....  | 6-47        |
| Maximum Freeze Time .....  | 6-47        |
| Ice Thickness Check .....  | 6-47        |
| Diagnosing Ice Thickness Control Circuitry .....                                     | 6-48        |
| <b>Water Level Control Circuitry</b> .....   | <b>6-50</b> |
| Water Level Probe Light .....  | 6-50        |
| Water Inlet Valve Safety Shut-Off .....  | 6-50        |
| Freeze Cycle Circuitry .....   | 6-50        |
| Harvest Cycle Circuitry .....  | 6-50        |
| Diagnosing Freeze Cycle Potable Water Level Control Circuitry .....                  | 6-51        |
| <b>Diagnosing An Ice Machine That Will Not Run</b> .....                             | <b>6-54</b> |

## Table of Contents (continued)

### Section 7 Refrigeration System

|  |      |
|--|------|
| <b>Sequence of Operation</b> .....   | 7-1  |
| Self-Contained Air or Water -Cooled Models .....                           | 7-1  |
| Remote Models .....  | 7-3  |
| Q1300/Q1600/Q1800 Refrigeration Tubing Schematics .....                    | 7-6  |
| <b>Operational Analysis (Diagnostics)</b> .....                            | 7-8  |
| General .....  | 7-8  |
| Before Beginning Service .....   | 7-9  |
| Ice Production Check .....   | 7-9  |
| Installation/Visual Inspection Checklist .....                             | 7-10 |
| Water System Checklist .....   | 7-10 |
| Ice Formation Pattern .....  | 7-11 |
| Safety Limits .....  | 7-13 |
| Analyzing Discharge Pressure   |      |
| During Freeze or Harvest Cycle .....                                       | 7-17 |
| Analyzing Suction Pressure   |      |
| During Freeze Cycle .....  | 7-18 |
| Single Expansion Valve Ice Machines -                                      |      |
| Comparing Evaporator Inlet and   |      |
| Outlet Temperatures .....  | 7-20 |
| Harvest Valve Temperature Check .....                                      | 7-21 |
| Discharge Line Temperature Analysis .....                                  | 7-22 |
| How to Use the Refrigeration System  |      |
| Operational Analysis Tables .....  | 7-24 |
| Refrigeration System Operational Analysis Tables .....                     | 7-25 |
| Harvest Pressure Regulating  |      |
| (H.P.R.) System .....  | 7-27 |
| Headmaster Control Valve .....   | 7-29 |
| <b>Pressure Control Specifications and Diagnostics</b> .....               | 7-31 |
| Fan Cycle Control .....  | 7-31 |
| High Pressure Cut-Out (HPCO) Control .....                                 | 7-31 |
| <b>Cycle Time/24 Hour Ice Production/Refrigerant Pressure Charts</b> ..... | 7-32 |
| Q200 Series .....  | 7-32 |
| Q280 Series .....  | 7-33 |
| Q320 Series .....  | 7-34 |
| Q370 Series .....  | 7-35 |
| Q420/450 Series .....  | 7-36 |
| Q450 Series .....  | 7-37 |
| Q600 Series .....  | 7-37 |
| Q800 Series .....  | 7-39 |
| Q1000 Series .....   | 7-40 |
| Q1300 Series .....   | 7-42 |
| Q1600 Series .....   | 7-43 |
| Q1800 Series .....   | 7-44 |

## Table of Contents (continued)

---

|  |             |
|--|-------------|
| <b>Refrigerant Recovery/Evacuation and Recharging</b> .....              | <b>7-46</b> |
| Normal Self-Contained Model Procedures .....                             | <b>7-46</b> |
| Normal Remote Model Procedures .....                                     | <b>7-48</b> |
| System Contamination Clean-Up .....                                      | <b>7-52</b> |
| Replacing Pressure Controls Without<br>Removing Refrigerant Charge ..... | <b>7-54</b> |
| Filter-Driers .....  | <b>7-56</b> |
| Total System Refrigerant Charges .....                                   | <b>7-56</b> |
| Refrigerant Definitions .....  | <b>7-57</b> |
| Refrigerant Re-Use Policy .....  | <b>7-58</b> |
| HFC Refrigerant Questions and Answers .....                              | <b>7-59</b> |



# Section 1

## General Information

### Model Numbers

This manual covers the following models:

| Self-Contained Air-Cooled     | Self-Contained Water-Cooled   | Remote                        |
|-------------------------------|-------------------------------|-------------------------------|
| QR0320A<br>QD0322A<br>QY0324A | QR0321W<br>QD0323W<br>QY0325W | --                            |
| QR0420A<br>QD0422A<br>QY0424A | QR0421W<br>QD0423W<br>QY0425W | --                            |
| QR0200A<br>QD0202A<br>QY0204A | QR0201W<br>QD0203W<br>QY0205W | --                            |
| QR0280A<br>QD0282A<br>QY0284A | QR0281W<br>QD0283W<br>QY0285W | --                            |
| QD0372A<br>QY0374A            | QD0373W<br>QY0375W            | --                            |
| QR0450A<br>QD0452A<br>QY0454A | QR0451W<br>QD0453W<br>QY0455W | QR0490N<br>QD0492N<br>QY0494N |
| QR0600A<br>QD0602A<br>QY0604A | QR0601W<br>QD0603W<br>QY0605W | QR0690N<br>QD0692N<br>QY0694N |
| QR0800A<br>QD0802A<br>QY0804A | QR0801W<br>QD0803W<br>QY0805W | QR0890N<br>QD0892N<br>QY0894N |
| QR1000A<br>QD1002A<br>QY1004A | QR1001W<br>QD1003W<br>QY1005W | QR1090N<br>QD1092N<br>QY1094N |
| QR1300A<br>QD1302A<br>QY1304A | QR1301W<br>QD1303W<br>QY1305W | QR1390N<br>QD1392N<br>QY1394N |
| --<br>--                      | QD1603W<br>QY1605W            | QD1693N<br>QY1694N            |
| QR1800A<br>QD1802A<br>QY1804A | QR1801W<br>QD1803W<br>QY1805W | QR1890N<br>QD1892N<br>QY1894N |

### How to Read a Model Number

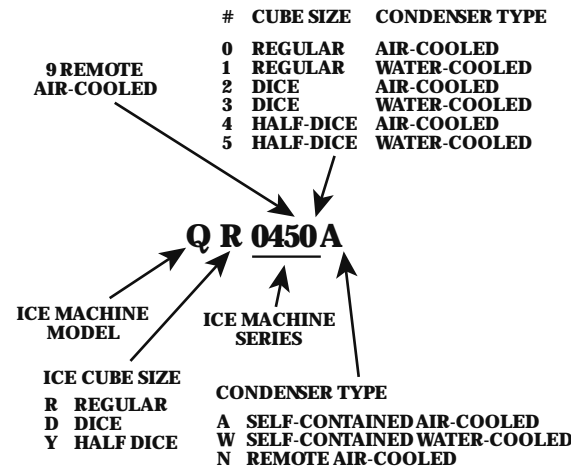

### Ice Cube Sizes



**Regular**

1-1/8" x 1-1/8" x 7/8"  
2.86 x 2.86 x 2.22 cm

**Dice**

7/8" x 7/8" x 7/8"  
2.22 x 2.22 x 2.22 cm

**Half Dice**

3/8" x 1-1/8" x 7/8"  
0.95 x 2.86 x 2.22 cm

NOTE: Model numbers ending in 3 indicate a 3-phase unit. Example: QY1804A3



#### Warning

#### PERSONAL INJURY POTENTIAL

Do not operate equipment that has been misused, abused, neglected, damaged, or altered/modified from that of original manufactured specifications.

**Model/Serial Number Location**

These numbers are required when requesting information from your local Manitowoc distributor, or Manitowoc Ice, Inc.

The model and serial number are listed on the MODEL/SERIAL NUMBER DECAL affixed to the ice machine, remote condenser and storage bin.

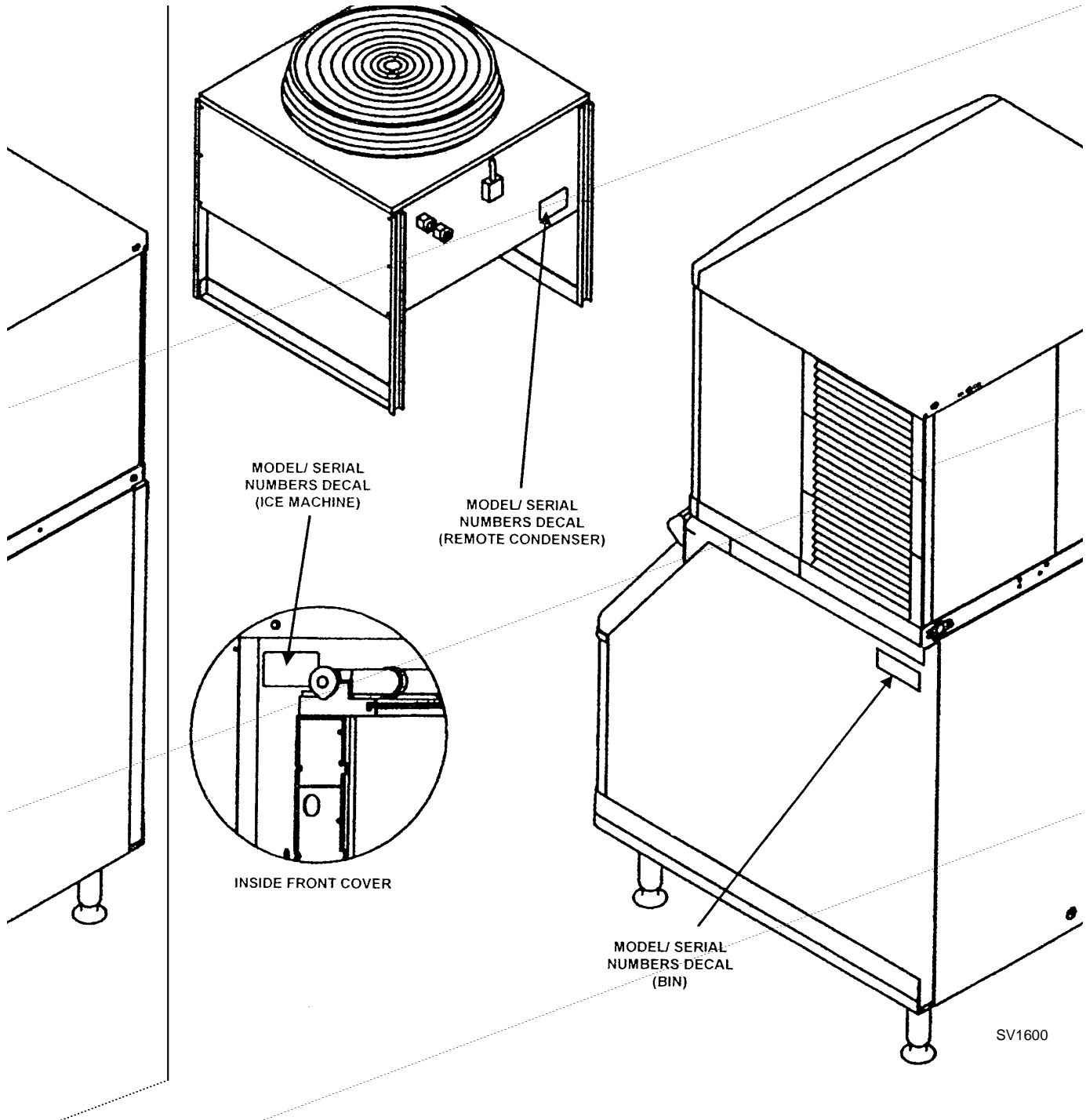

**Figure 1-1. Model/Serial Number Location**

## Warranty Coverage

### GENERAL

The following Warranty outline is provided for your convenience. For a detailed explanation, read the warranty bond shipped with each product.

Contact your local Manitowoc Distributor or Manitowoc Ice, Inc. if you need further warranty information.

#### Important

This product is intended exclusively for commercial application. No warranty is extended for personal, family, or household purposes.

### PARTS

1. Manitowoc warrants the ice machine against defects in materials and workmanship, under normal use and service for three (3) years from the date of original installation.
2. The evaporator and compressor are covered by an additional two (2) year (five years total) warranty beginning on the date of the original installation.

### LABOR

1. Labor required to repair or replace defective components is covered for three (3) years from the date of original installation.
2. The evaporator is covered by an additional two (2) year (five years total) labor warranty beginning on the date of the original installation.

### EXCLUSIONS

The following items are not included in the ice machine's warranty coverage:

1. **Normal maintenance**, adjustments and cleaning.
2. Repairs due to unauthorized modifications to the ice machine or use of non-standard parts without prior written approval from Manitowoc Ice, Inc.
3. Damage caused by improper installation of the ice machine, electrical supply, water supply or drainage, or damage caused by floods, storms, or other acts of God.
4. **Premium labor rates** due to holidays, **overtime**, etc.; travel time; flat rate service call charges; mileage and miscellaneous tools and material charges not listed on the payment schedule. Additional labor charges resulting from the inaccessibility of equipment are also excluded.
5. Parts or assemblies subjected to misuse, abuse, neglect or accidents.
6. Damage or problems caused by installation, cleaning and/or maintenance procedures inconsistent with the technical instructions provided in this manual.
7. This product is intended exclusively for commercial application. No warranty is extended for personal, family, or household purposes.

### AUTHORIZED WARRANTY SERVICE

To comply with the provisions of the warranty, a refrigeration service company qualified and authorized by a Manitowoc distributor, or a Contracted Service Representative must perform the warranty repair.

THIS PAGE INTENTIONALLY LEFT BLANK

## Section 2 Installation Instructions

### General

Refer to Installation Manual for complete installation guidelines.

### Important

Failure to follow these installation guidelines may affect warranty coverage.

### Ice Machine Dimensions

#### Q320/Q370/Q420 ICE MACHINES

**WATER COOLED**

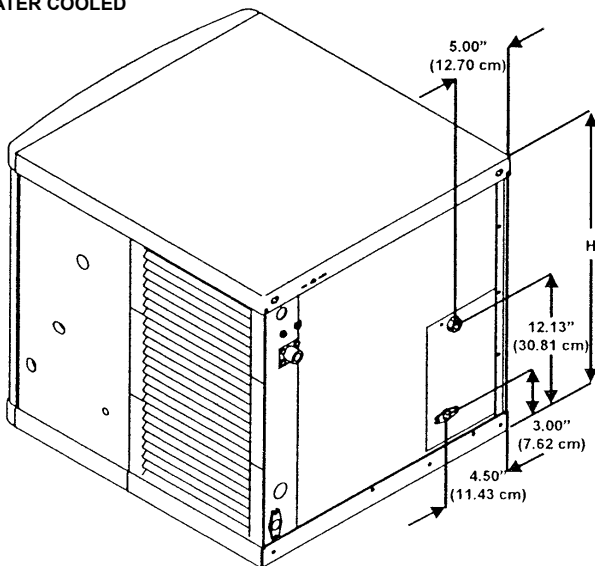

SV1602

**AIR COOLED**

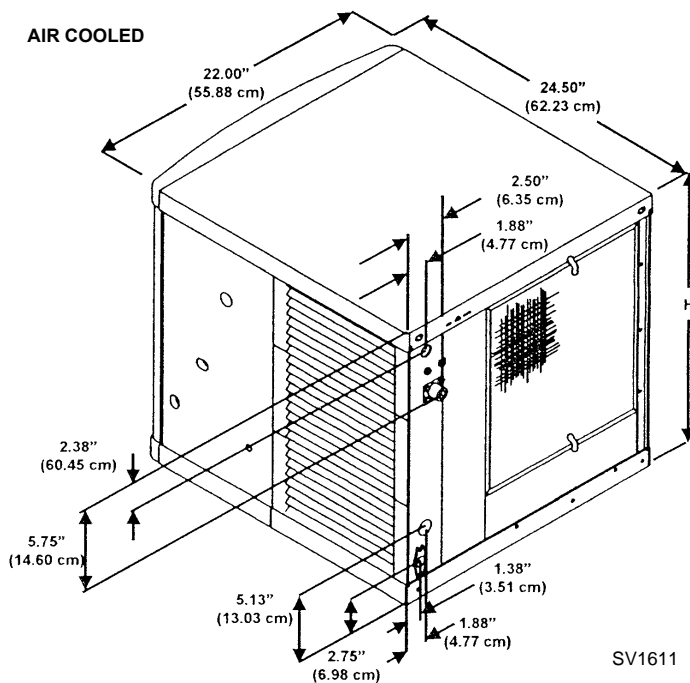

SV1611

| Ice Machine | Dimension H       |
|-------------|-------------------|
| Q320        | 21.5 in (54.6 cm) |
| Q370        | 21.5 in (54.6 cm) |
| Q420        | 26.5 in (67.3 cm) |

Q200 – Q1000 ICE MACHINES

Q1300/Q1600/Q1800 ICE MACHINES

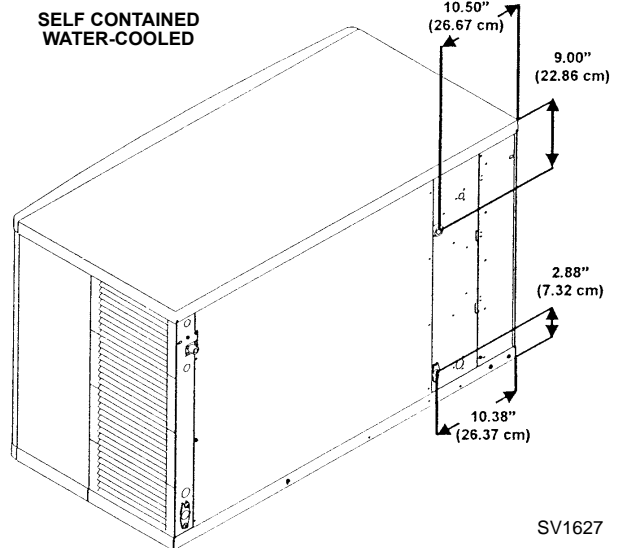
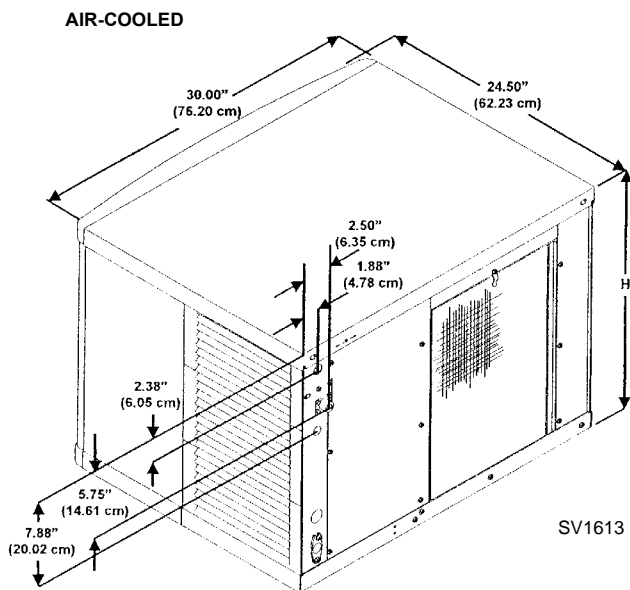
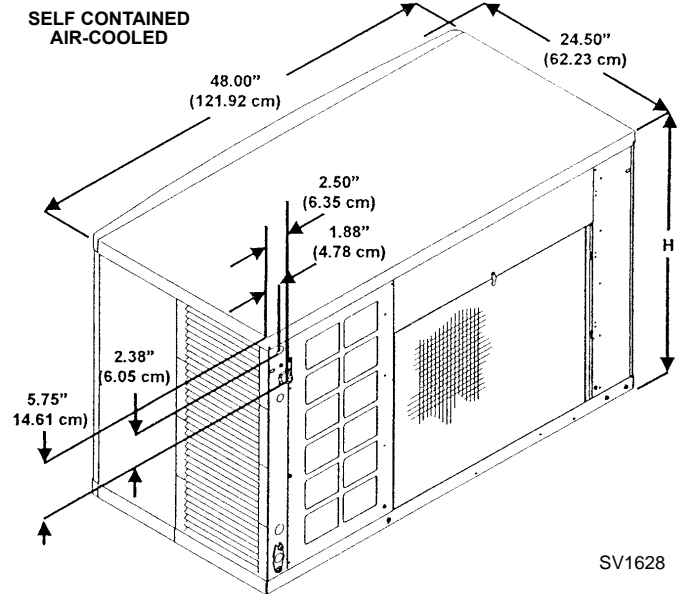
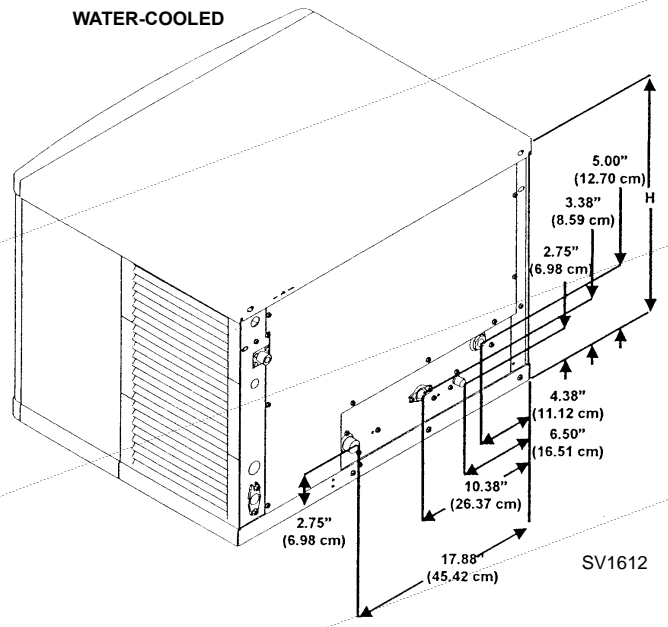

| Ice Machine | Dimension H       |
|-------------|-------------------|
| Q200 – Q280 | 16.5 in (41.9 cm) |
| Q450        | 21.5 in (54.6 cm) |
| Q600        | 21.5 in (54.6 cm) |
| Q800        | 26.5 in (67.3 cm) |
| Q1000       | 29.5 in (74.9 cm) |

| Ice Machine | Dimension H       |
|-------------|-------------------|
| Q1300/Q1600 | 29.5 in (74.9 cm) |
| Q1800       | 29.5 in (74.9 cm) |

Q1300/Q1600/Q1800 ICE MACHINES (CONT.)

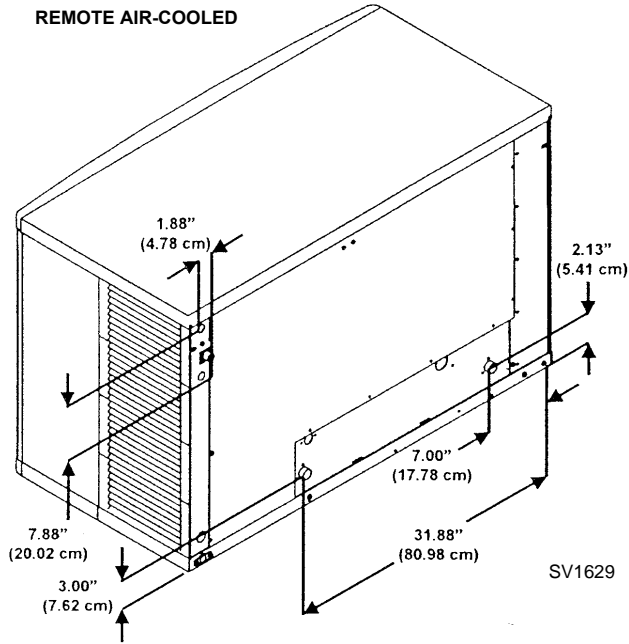

Ice Storage Bin Dimensions

S170/S400/S570 ICE STORAGE BINS

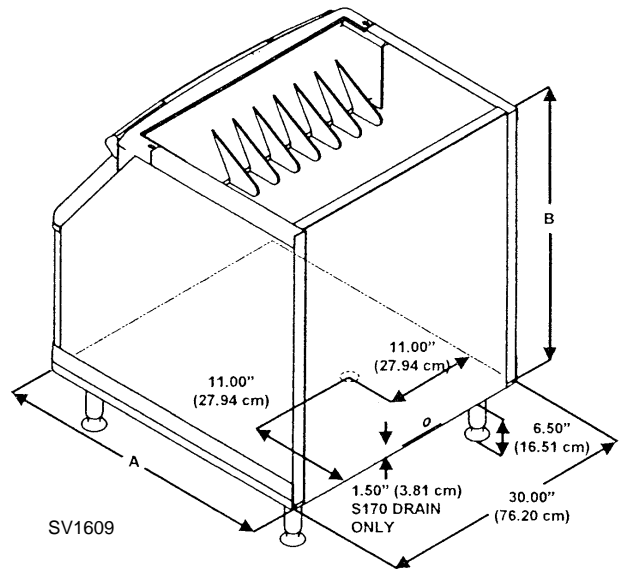

| Bin Model | Dimension A       | Dimension B        |
|-----------|-------------------|--------------------|
| S170      | 29.5 in (74.9 cm) | 19.1 in (48.5 cm)  |
| S400      | 34.0 in (86.3 cm) | 32.0 in (81.3 cm)  |
| S570      | 34.0 in (86.3 cm) | 44.0 in (111.7 cm) |

S320/S420 ICE STORAGE BINS

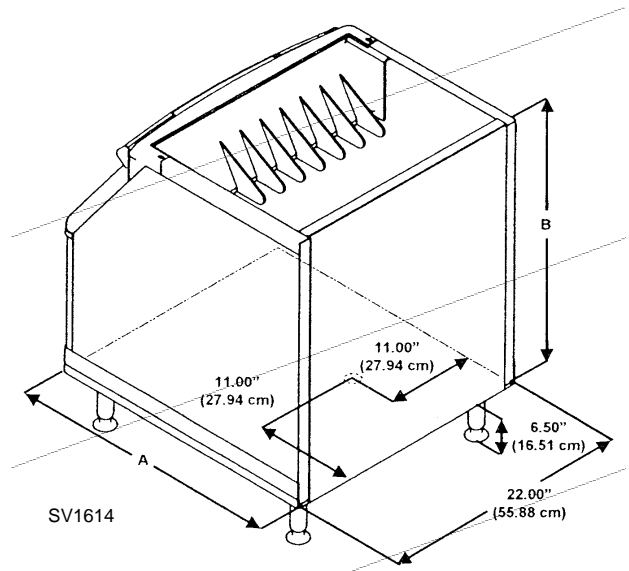

| Bin Model | Dimension A       | Dimension B        |
|-----------|-------------------|--------------------|
| S320      | 34.0 in (86.3 cm) | 32.0 in (81.3 cm)  |
| S420      | 34.0 in (86.3 cm) | 44.0 in (111.7 cm) |

S970 ICE STORAGE BINS

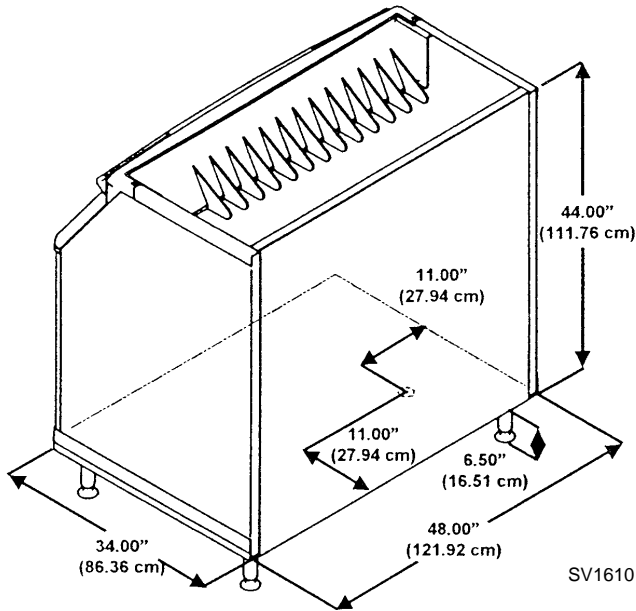

Remote Condenser Dimensions

JC0495/JC0895/JC1095/JC1395

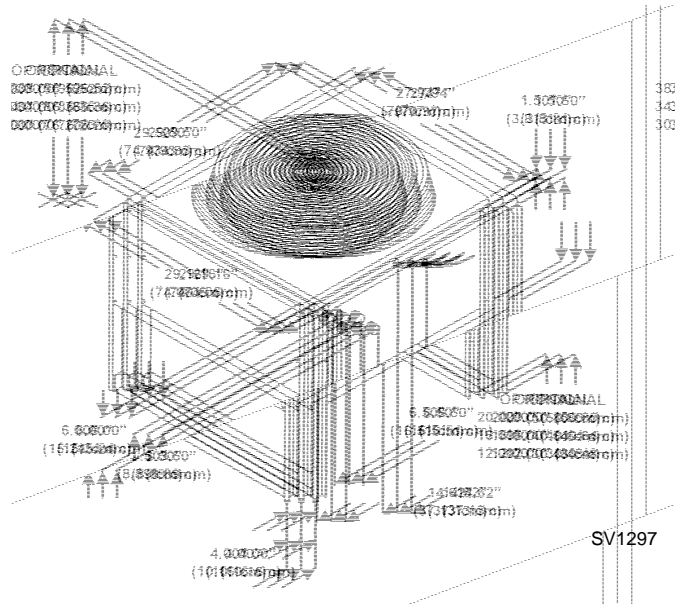

**Warning**

All Manitowoc ice machines require the ice storage system (bin, dispenser, etc.) to incorporate an ice deflector.

The Q1300, Q1600 and Q1800 series ice machines require adding Manitowoc Ice Deflector Kit K00139 when installing with non-Manitowoc ice storage systems.

Prior to using a non-Manitowoc ice storage system with other Manitowoc ice machines, contact the manufacturer to assure their ice deflector is compatible with Manitowoc ice machines.

JC1895

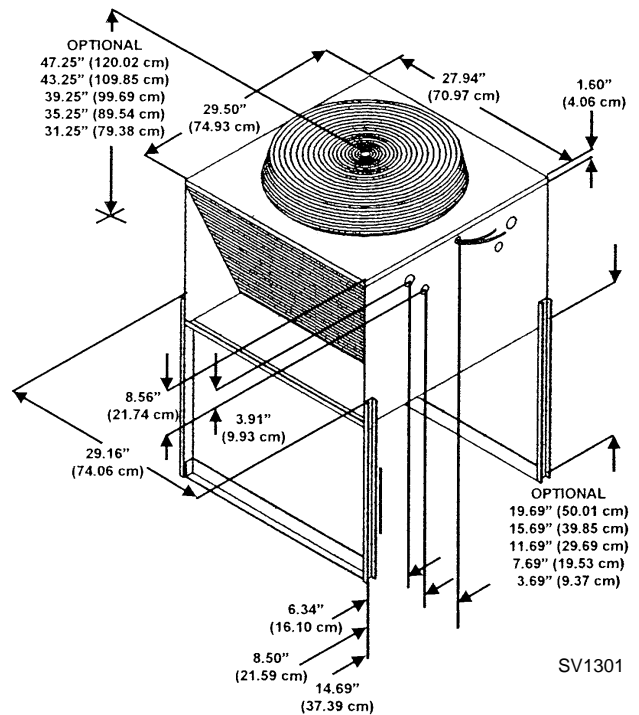



**Location of Ice Machine**

The location selected for the ice machine must meet the following criteria. If any of these criteria are not met, select another location.

- The location must be free of airborne and other contaminants.
- The air temperature must be at least 35°F (1.6°C), but must not exceed 110°F (43.4°C).
- The location must not be near heat-generating equipment or in direct sunlight.
- The location must not obstruct air flow through or around the ice machine. Refer to the chart below for clearance requirements.

| Q1300/Q1600/<br>Q1800 | Self-Contained<br>Air-Cooled | Water-Cooled<br>and Remote |
|-----------------------|------------------------------|----------------------------|
| Top/Sides             | 24" (61 cm)                  | 8" (20.3 cm)               |
| Back                  | 12" (30.5 cm)                | 5" (12.7 cm)               |

| Q370      | Self-Contained<br>Air-Cooled | Water-Cooled |
|-----------|------------------------------|--------------|
| Top/Sides | 12" (30.5 cm)                | 5" (12.7 cm) |
| Back      | 5" (127 mm)                  | 5" (12.7 cm) |

| All other<br>Q models | Self-Contained<br>Air-Cooled | Water-Cooled<br>and Remote |
|-----------------------|------------------------------|----------------------------|
| Top/Sides             | 8" (20.3 cm)                 | 8" (20.3 cm)               |
| Back                  | 5" (12.7 cm)                 | 5" (12.7 cm)               |

There is no minimum clearance required. This value is recommended for efficient operation and servicing only. Q1600 is not available as an air-cooled model.

**⚠ Caution**

The ice machine must be protected if it will be subjected to temperatures below 32°F (0°C). Failure caused by exposure to freezing temperatures is not covered by the warranty. See "Removal from Service/Winterization" on **Page 3-14**.

**Stacking Two Ice Machines on a Single Storage Bin**

A stacking kit is required for stacking two ice machines. Installation instructions are supplied with the stacking kit.

| Q450/Q600/<br>Q800/Q1000 | Stacked<br>Self-Contained<br>Air-Cooled | Stacked<br>Water-Cooled<br>and Remote* |
|--------------------------|---|--|
| Top/Sides                | 16" (40.64 cm)                          | 5" (12.70 cm)                          |
| Back                     | 5" (12.70 cm)                           | 5" (12.70 cm)                          |
| Q1300/Q1600/<br>Q1800    |   |  |
| Top/Sides                | 48" (121.92 cm)                         | 24" (60.96 cm)                         |
| Back                     | 12" (30.48 cm)                          | 12" (30.48 cm)                         |

\*There is no minimum clearance required. This value is recommended for efficient operation and servicing only. Q1600 is not available as an air-cooled model.

**Ice Machine Heat of Rejection**

| Series<br>Ice Machine | Heat of Rejection |        |
|-----------------------|-------------------|--------|
|                       | Air Conditioning  | Peak   |
| Q320                  | 4,600             | 6,200  |
| Q370                  | 3,900             | 5,950  |
| Q420                  | 7,000             | 9,600  |
| Q200                  | 3,800             | 5,000  |
| Q280                  | 3,800             | 6,000  |
| Q450                  | 7,000             | 9,600  |
| Q600                  | 9,000             | 13,900 |
| Q800                  | 12,400            | 19,500 |
| Q1000                 | 16,000            | 24,700 |
| Q1300                 | 24,000            | 35,500 |
| Q1600                 | 24,000            | 35,500 |
| Q1800                 | 36,000            | 50,000 |

B.T.U./Hour

Because the heat of rejection varies during the ice making cycle, the figure shown is an average.

Ice machines, like other refrigeration equipment, reject heat through the condenser. It is helpful to know the amount of heat rejected by the ice machine when sizing air conditioning equipment where self-contained air-cooled ice machines are installed.

This information is also necessary when evaluating the benefits of using water-cooled or remote condensers to reduce air conditioning loads. The amount of heat added to an air conditioned environment by an ice machine using a water-cooled or remote condenser is negligible.

Knowing the amount of heat rejected is also important when sizing a cooling tower for a water-cooled condenser. Use the peak figure for sizing the cooling tower.

**Leveling the Ice Storage Bin**

1. Screw the leveling legs onto the bottom of the bin.
2. Screw the foot of each leg in as far as possible.

**⚠ Caution**

The legs must be screwed in tightly to prevent them from bending.

3. Move the bin into its final position.
4. Level the bin to assure that the bin door closes and seals properly. Use a level on top of the bin. Turn each foot as necessary to level the bin.

NOTE: An optional caster assembly is available for use in place of the legs. Installation instructions are supplied with the casters.

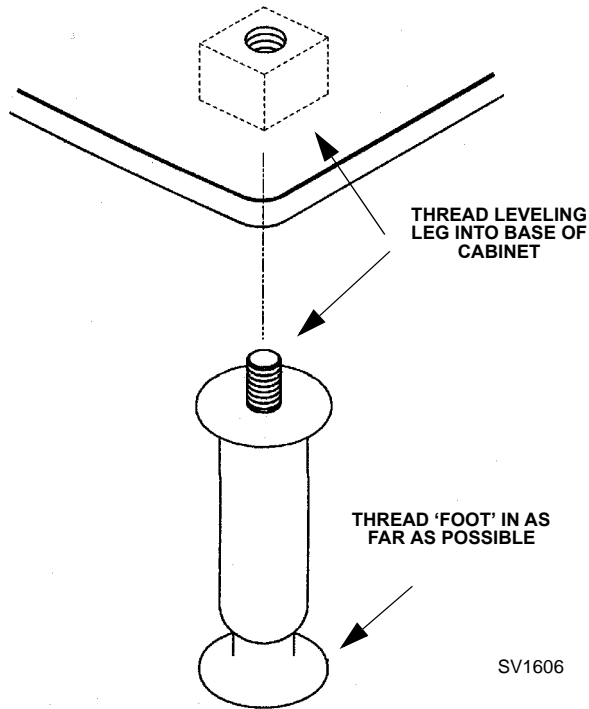
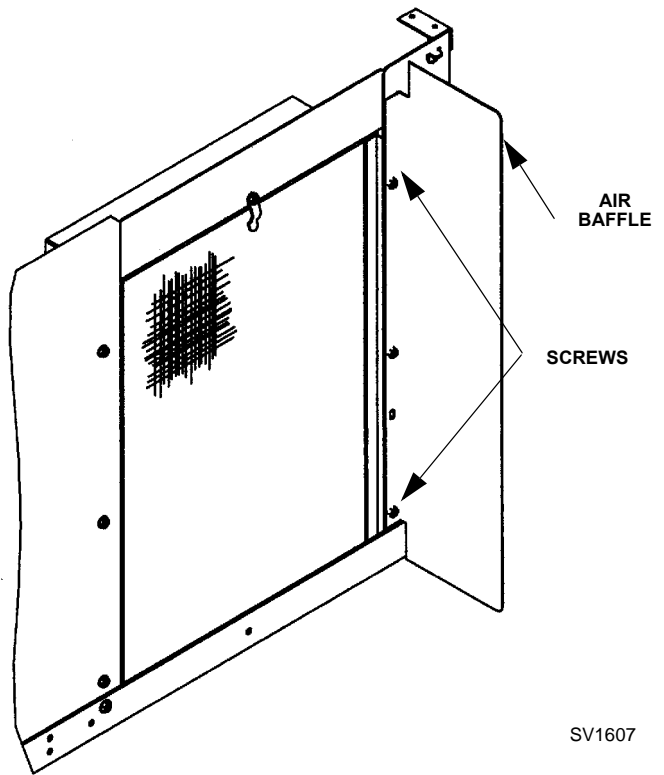

**Figure 2-1. Leveling Leg and Foot**

**Air-Cooled Baffle**

The air-cooled baffle prevents condenser air from recirculating. To install:

1. Remove the back panel screws next to the condenser.
2. Align the mounting holes in the air baffle with the screw holes and reinstall the screws.



**Figure 2-2. Air Baffle**

## Electrical Service

### GENERAL

 **Warning**

All wiring must conform to local, state and national codes.

### VOLTAGE

The maximum allowable voltage variation is  $\pm 10\%$  of the rated voltage at ice machine start-up (when the electrical load is highest).

 **Warning**

The ice machine must be grounded in accordance with national and local electrical codes.

### FUSE/CIRCUIT BREAKER

A separate fuse/circuit breaker must be provided for each ice machine. Circuit breakers must be H.A.C.R. rated (does not apply in Canada).

### MINIMUM CIRCUIT AMPACITY

The minimum circuit ampacity is used to help select the wire size of the electrical supply. (Minimum circuit ampacity is not the ice machine's running amp load.)

The wire size (or gauge) is also dependent upon location, materials used, length of run, etc., so it must be determined by a qualified electrician.

Table 2-1. Q320/370/420 Ice Machines

| Ice Machine | Voltage Phase Cycle | Air-Cooled                   |                      | Water Cooled                 |                      |
|-------------|---------------------|------------------------------|----------------------|------------------------------|----------------------|
|             |                     | Maximum Fuse/Circuit Breaker | Minimum Circuit Amps | Maximum Fuse/Circuit Breaker | Minimum Circuit Amps |
| Q320        | 115/1/60            | 15                           | 11.2                 | 15                           | 10.5                 |
|             | 208-230/1/60        | 15                           | 4.8                  | 15                           | 4.2                  |
|             | 230/1/50            | 15                           | 5.2                  | 15                           | 4.7                  |
| Q370        | 115/1/60            | 20                           | 12.9                 | 20                           | 12.2                 |
|             | 208-230/1/60        | 15                           | 6.2                  | 15                           | 5.8                  |
|             | 230/1/50            | 15                           | 6.2                  | 15                           | 5.8                  |
| Q420        | 115/1/60            | 20                           | 12.3                 | 20                           | 11.4                 |
|             | 208-230/1/60        | 15                           | 7.8                  | 15                           | 7.4                  |
|             | 230/1/50            | 15                           | 6.3                  | 15                           | 5.9                  |

Table 2-2. Q200 - Q1000 Ice Machines

| Ice Machine | Voltage Phase Cycle | Air-Cooled                   |                      | Water Cooled                 |                      | Remote                       |                      |
|-------------|---------------------|------------------------------|----------------------|------------------------------|----------------------|------------------------------|----------------------|
|             |                     | Maximum Fuse/Circuit Breaker | Minimum Circuit Amps | Maximum Fuse/Circuit Breaker | Minimum Circuit Amps | Maximum Fuse/Circuit Breaker | Minimum Circuit Amps |
| Q200        | 115/1/60            | 15                           | 11.6                 | 15                           | 10.9                 | N/A                          | N/A                  |
|             | 208-230/1/60        | 15                           | 5.4                  | 15                           | 4.8                  | N/A                          | N/A                  |
|             | 230/1/50            | 15                           | 5.2                  | 15                           | 4.9                  | N/A                          | N/A                  |
| Q280        | 115/1/60            | 20                           | 12.6                 | 20                           | 11.7                 | N/A                          | N/A                  |
|             | 208-230/1/60        | 15                           | 5.7                  | 15                           | 5.2                  | N/A                          | N/A                  |
|             | 230/1/50            | 15                           | 5.7                  | 15                           | 5.2                  | N/A                          | N/A                  |
| Q450        | 115/1/60            | 20                           | 12.8                 | 20                           | 11.9                 | 20                           | 13.6                 |
|             | 208-230/1/60        | 15                           | 7.8                  | 15                           | 7.4                  | N/A                          | N/A                  |
|             | 230/1/50            | 15                           | 6.1                  | 15                           | 5.7                  | N/A                          | N/A                  |
| Q600        | 208-230/1/60        | 15                           | 9.2                  | 15                           | 8.7                  | 15                           | 9.3                  |
|             | 230/1/50            | 15                           | 9.2                  | 15                           | 8.8                  | 15                           | 9.4                  |
| Q800        | 208-230/1/60        | 20                           | 12.1                 | 20                           | 11.4                 | 20                           | 11.9                 |
|             | 208-230/3/60        | 15                           | 8.9                  | 15                           | 8.2                  | 15                           | 8.9                  |
|             | 230/1/50            | 20                           | 12.0                 | 20                           | 10.6                 | 20                           | 11.2                 |
| Q1000       | 208-230/1/60        | 20                           | 14.3                 | 20                           | 13.2                 | 20                           | 14.2                 |
|             | 208-230/3/60        | 15                           | 9.8                  | 15                           | 8.8                  | 15                           | 9.9                  |
|             | 230/1/50            | 20                           | 15.6                 | 20                           | 14.2                 | 20                           | 14.6                 |
| Q1300       | 208-230/1/60        | 30                           | 19.5                 | 30                           | 18.1                 | 30                           | 19.8                 |
|             | 208-230/3/60        | 20                           | 13.1                 | 20                           | 11.6                 | 20                           | 12.7                 |
|             | 230/1/50            | 30                           | 15.7                 | 30                           | 14.3                 | 30                           | 14.7                 |
|             | 380-415/3/50        | N/A                          | N/A                  | N/A                          | N/A                  | 15                           | 7.3                  |
| Q1600       | 208-230/1/60        | N/A                          | N/A                  | 30                           | 17.2                 | 30                           | 18.2                 |
|             | 208-230/3/60        | N/A                          | N/A                  | 20                           | 11.0                 | 20                           | 12.0                 |
|             | 230/1/50            | N/A                          | N/A                  | N/A                          | N/A                  | N/A                          | N/A                  |
|             | 380-415/3/50        | N/A                          | N/A                  | N/A                          | N/A                  | N/A                          | N/A                  |
| Q1800       | 208-230/1/60        | 40                           | 28.1                 | 40                           | 26.7                 | 40                           | 26.9                 |
|             | 208-230/3/60        | 20                           | 15.5                 | 20                           | 14.1                 | 20                           | 13.9                 |
|             | 230/1/50            | 40                           | 23.3                 | 40                           | 21.9                 | 40                           | 22.2                 |
|             | 380-415/3/50        | N/A                          | N/A                  | N/A                          | N/A                  | 15                           | 9.1                  |

Self-Contained Electrical Wiring Connections

**Warning**

These diagrams are not intended to show proper wire routing, wire sizing, disconnects, etc., only the correct wire connections.

All electrical work, including wire routing and grounding, must conform to local, state and national electrical codes.

Though wire nuts are shown in the drawings, the ice machine field wiring connections may use either wire nuts or screw terminals.

**SELF CONTAINED ICE MACHINE  
115/1/60 OR 208-230/1/60**

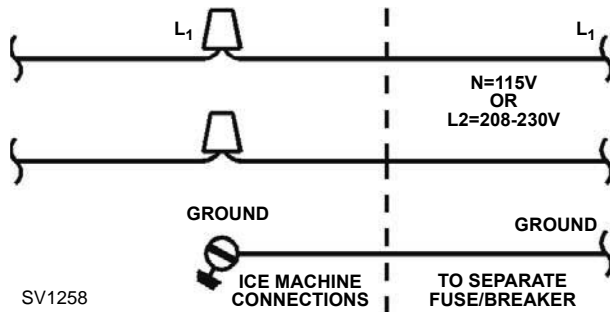

**SELF CONTAINED ICE MACHINE  
208-230/3/60**

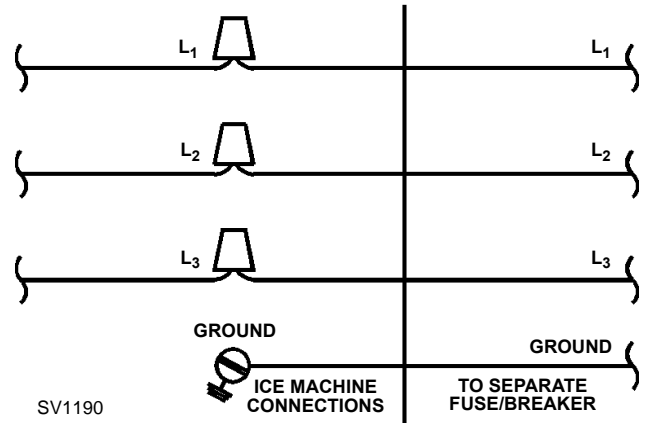

**SELF CONTAINED ICE MACHINE  
230/1/50**

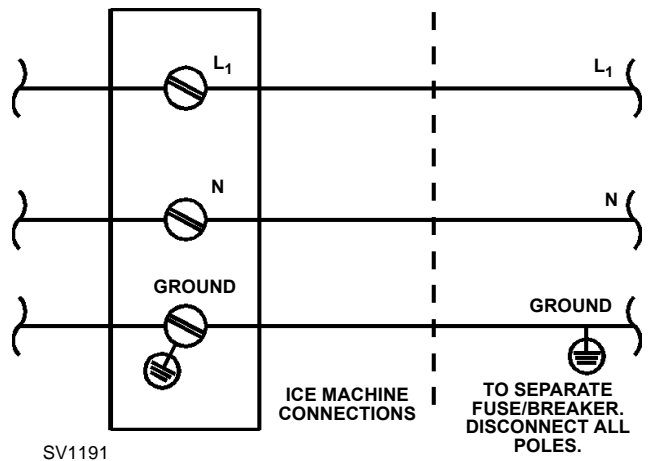

**For United Kingdom Only**

As the colours of the wires in the mains lead of the appliance may not correspond with the coloured markings identifying the terminals in your plug, proceed as follows:

- The wire which is coloured green and yellow must be connected to the terminal in the plug which is marked with the letter E or by the earth ground symbol  or coloured green or green and yellow.
- The wire coloured blue must be connected to the terminal which is marked with the letter N or coloured black.
- The wire coloured brown must be connected to the terminal which is marked with the letter L or coloured red.

Remote Electrical Wiring Connections

**Warning**

These diagrams are not intended to show proper wire routing, wire sizing, disconnects, etc., only the correct wire connections.

All electrical work, including wire routing and grounding, must conform to local, state and national electrical codes.

Though wire nuts are shown in the drawings, the ice machine field wiring connections may use either wire nuts or screw terminals.

**REMOTE ICE MACHINE WITH SINGLE CIRCUIT MODEL CONDENSER**  
115/1/60 OR 208-230/1/60

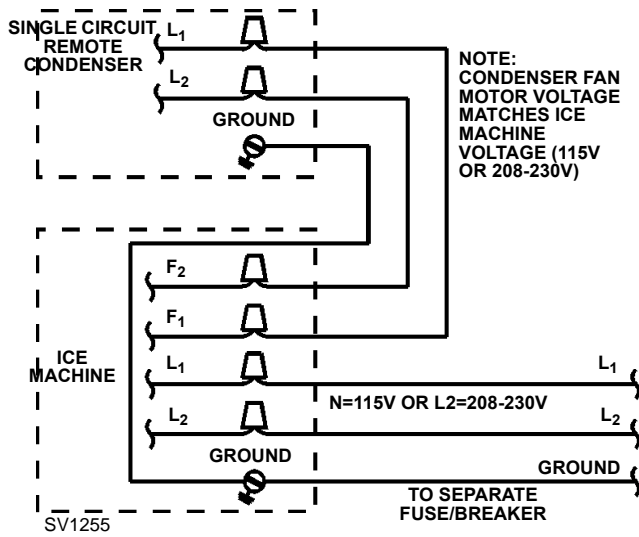

**REMOTE ICE MACHINE WITH SINGLE CIRCUIT MODEL CONDENSER**  
208-230/3/60 OR 380-415/3/50

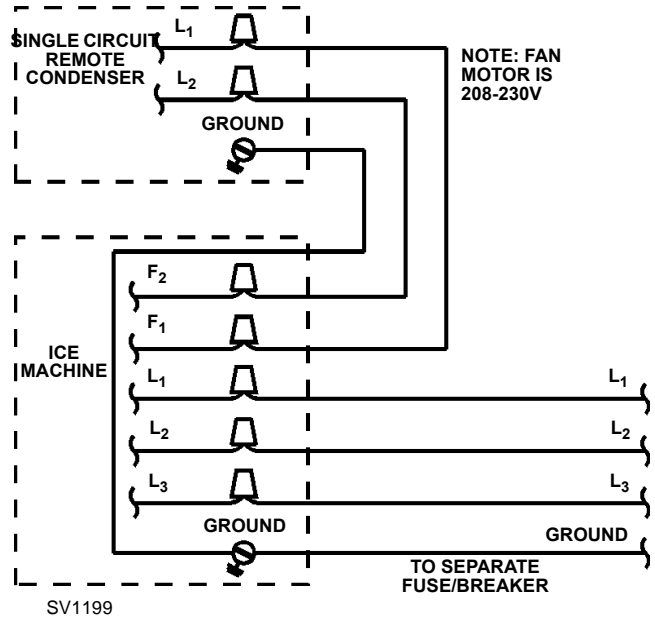

**REMOTE ICE MACHINE WITH SINGLE CIRCUIT MODEL CONDENSER**  
230/1/50

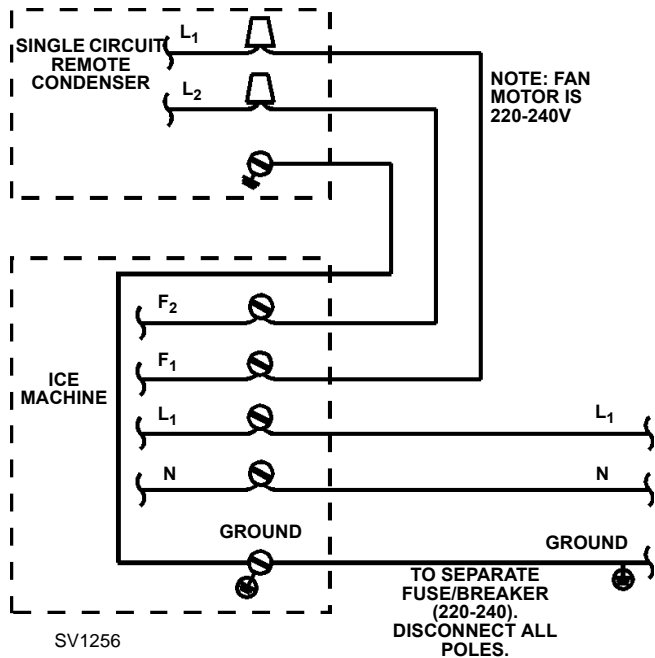

## Water Supply and Drain Requirements

### WATER SUPPLY

Local water conditions may require treatment of the water to inhibit scale formation, filter sediment, and remove chlorine odor and taste.

#### Important

If you are installing a Manitowoc water filter system, refer to the Installation Instructions supplied with the filter system for ice making water inlet connections.

### WATER INLET LINES

Follow these guidelines to install water inlet lines:

- Do not connect the ice machine to a hot water supply. Be sure all hot water restrictors installed for other equipment are working. (Check valves on sink faucets, dishwashers, etc.)
- If water pressure exceeds the maximum recommended pressure, obtain a water pressure regulator from your Manitowoc distributor.
- Install a water shut-off valve for both the ice making and condenser water lines.
- Insulate water inlet lines to prevent condensation.

### DRAIN CONNECTIONS

Follow these guidelines when installing drain lines to prevent drain water from flowing back into the ice machine and storage bin:

- Drain lines must have a 1.5 inch drop per 5 feet of run (2.5 cm per meter), and must not create traps.
- The floor drain must be large enough to accommodate drainage from all drains.
- Run separate bin and ice machine drain lines. Insulate them to prevent condensation.
- Vent the bin and ice machine drain to the atmosphere. Do not vent the condenser drain on water-cooled models.

### Cooling Tower Applications (Water-Cooled Models)

A water cooling tower installation does not require modification of the ice machine. The water regulator valve for the condenser continues to control the refrigeration discharge pressure.

It is necessary to know the amount of heat rejection, and the pressure drop through the condenser and water valves (inlet and outlet) when using a cooling tower on an ice machine.

- Water entering the condenser must not exceed 90°F (32.2°C).
- Water flow through the condenser must not exceed 5 gallons (19 liters) per minute.
- Allow for a pressure drop of 7 psi (48 kPA) between the condenser water inlet and the outlet of the ice machine.
- Water exiting the condenser must not exceed 110°F (43.3°C).

WATER SUPPLY AND DRAIN LINE SIZING/CONNECTIONS

**⚠ Caution**  
Plumbing must conform to state and local codes.

| Location               | Water Temperature                       | Water Pressure                                       | Ice Machine Fitting   | Tubing Size Up to Ice Machine Fitting  |
|------------------------|---|--|---|--|
| Ice Making Water Inlet | 33°F (0.6°C) Min.<br>90°F (32.2°C) Max. | 20 psi (137.9 kPA) Min.<br>80 psi (551.5 kPA) Max.   | 3/8" Female Pipe Thread   | 3/8" (9.5 mm) minimum inside diameter  |
| Ice Making Water Drain | ---                                     | ---  | 1/2" Female Pipe Thread   | 1/2" (12.7 mm) minimum inside diameter |
| Condenser Water Inlet  | 33°F (0.6°C) Min.<br>90°F (32.2°C) Max. | 20 psi (137.9 kPA) Min.<br>150 psi (1034.2 kPA) Max. | Q1300/Q1600/Q1800 - 1/2" Female Pipe Thread<br>All Others - 3/8" Female Pipe Thread |  |
| Condenser Water Drain  | ---                                     | ---  | 1/2" Female Pipe Thread   | 1/2" (12.7 mm) minimum inside diameter |
| Bin Drain              | ---                                     | ---  | 3/4" Female Pipe Thread   | 3/4" (19.1 mm) minimum inside diameter |

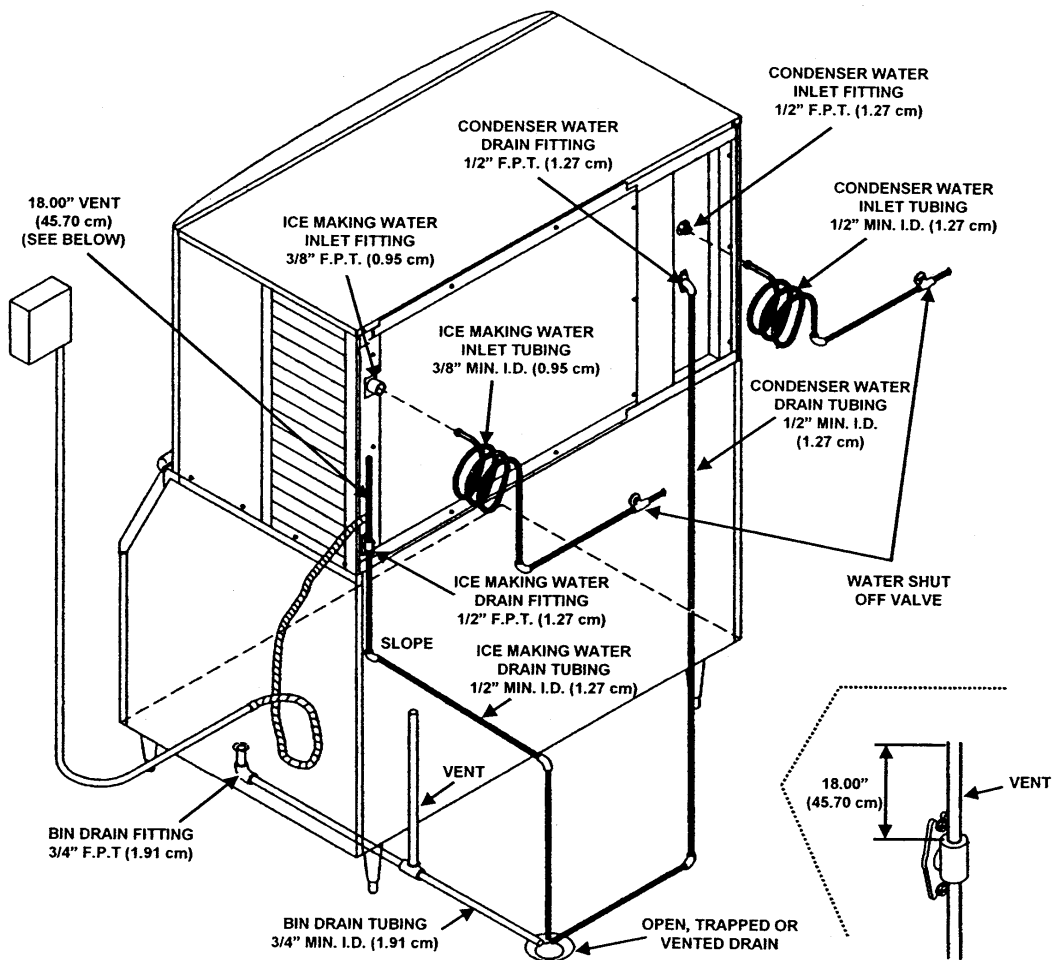

Figure 2-3. Typical Water Supply Drain Installation

SV1626



**Remote Condenser/Line Set Installation**

| Ice Machine | Remote Single Circuit Condenser | Line Set*   |
|-------------|---------------------------------|-------------|
| Q490        | JC0495                          | RT-20-R404A |
| Q690        | JC0895                          | RT-35-R404A |
| Q890        |                                 | RT-50-R404A |
| Q1090       | JC1095                          |             |
| Q1390       | JC1395                          | RL-20-R404A |
| Q1690       | JC1695                          | RL-35-R404A |
| Q1890       | JC1895                          | RL-50-R404A |

| *Line Set | Discharge Line | Liquid Line    |
|-----------|----------------|----------------|
| RT        | 1/2" (1.27 cm) | 5/16" (.79 cm) |
| RL        | 1/2" (1.27 cm) | 3/8" (.95 cm)  |

| Air Temperature Around the Condenser |              |
|--------------------------------------|--------------|
| Minimum                              | Maximum      |
| -20°F (-28.9°C)                      | 120°F (49°C) |

**REMOTE ICE MACHINES REFRIGERANT CHARGE**

Each remote ice machine ships from the factory with a refrigerant charge appropriate for installation with line sets of up to 50' (15.25 m). The serial tag on the ice machine indicates the refrigerant charge.

| Ice Machine | Nameplate Charge<br>(Charge Shipped in Ice Machine) | Refrigerant to be Added for<br>50'-100' Line Sets | Maximum System Charge<br>(Never Exceed) |
|-------------|---|---|---|
| Q490        | 6 lb. (96 oz.)                                      | None  | 6 lb. (96 oz.)                          |
| Q690        | 8 lb. (128 oz.)                                     | None  | 8 lb. (128 oz.)                         |
| Q890        | 8 lb. (128 oz.)                                     | None  | 8 lb. (128 oz.)                         |
| Q1090       | 9.5 lb. (152 oz.)                                   | None  | 9.5 lb. (152 oz.)                       |
| Q1390       | 12.5 lb. (200 oz.)                                  | 1.5 lb. (24 oz)                                   | 14 lb. (224 oz.)                        |
| Q1690       | 15 lb. (240 oz.)                                    | 2.0 lb. (32 oz)                                   | 17 lb. (272 oz.)                        |
| Q1890       | 15 lb. (240 oz.)                                    | 2.0 lb. (32 oz)                                   | 17 lb. (272 oz.)                        |

Additional refrigerant may be required for installations using line sets between 50' and 100' (15.25-30.5 m) long. If additional refrigerant is required, an additional label located next to the Model/Serial Numbers decal states the amount of refrigerant to be added.

**IMPORTANT  
EPA CERTIFIED TECHNICIANS**

If remote line set length is between 50' and 100' (15.25-30.5 m), add **1.5 lb. (24 oz) (0.68 kg)** of refrigerant to the nameplate charge.

Tubing length: \_\_\_\_\_

Refrigerant added to nameplate: \_\_\_\_\_

New total refrigerant charge: \_\_\_\_\_

**Figure 2-4. Typical Additional Refrigerant Label**

If there is no additional label, the nameplate charge is sufficient for line sets up to 100' (30.5 m). (See the chart below.)

 **WARNING**

**Potential Personal Injury Situation**

The ice machine contains refrigerant charge. Installation of the line sets must be performed by a properly trained and EPA certified refrigeration technician aware of the  **dangers of dealing with refrigerant**  charged equipment.

**GENERAL**

Condensers must be mounted horizontally with the fan motor on top.

Remote condenser installations consist of vertical and horizontal line sets between the ice machine and the condenser. When combined, they must fit within approved specifications. The following guidelines, drawings and calculation methods must be followed to verify a proper remote condenser installation.

**⚠ Caution**

The 60 month compressor warranty (including the 36 month labor replacement warranty) will not apply if the remote ice machine is not installed according to specifications.

This warranty also will not apply if the refrigeration system is modified with a condenser, heat reclaim device, or other parts or assemblies not manufactured by Manitowoc Ice, Inc., unless specifically approved in writing by Manitowoc Ice, Inc.

**GUIDELINES FOR ROUTING LINE SETS**

First, cut a 2.5" (6.35 cm) circular hole in the wall or roof for tubing routing. The line set end with the 90° bend will connect to the ice machine. The straight end will connect to the remote condenser.

Follow these guidelines when routing the refrigerant lines. This will help insure proper performance and service accessibility.

1. Optional - Make the service loop in the line sets (See Figure 2-5). This permits easy access to the ice machine for cleaning and service. Do not use hard rigid copper at this location.
2. Required - Do not form traps in the refrigeration lines (except the service loop). Refrigerant oil must be free to drain toward the ice machine or the condenser. Route excess tubing in a supported downward horizontal spiral (See Figure 2-5). Do not coil tubing vertically.
3. Required - Keep outdoor refrigerant line runs as short as possible.

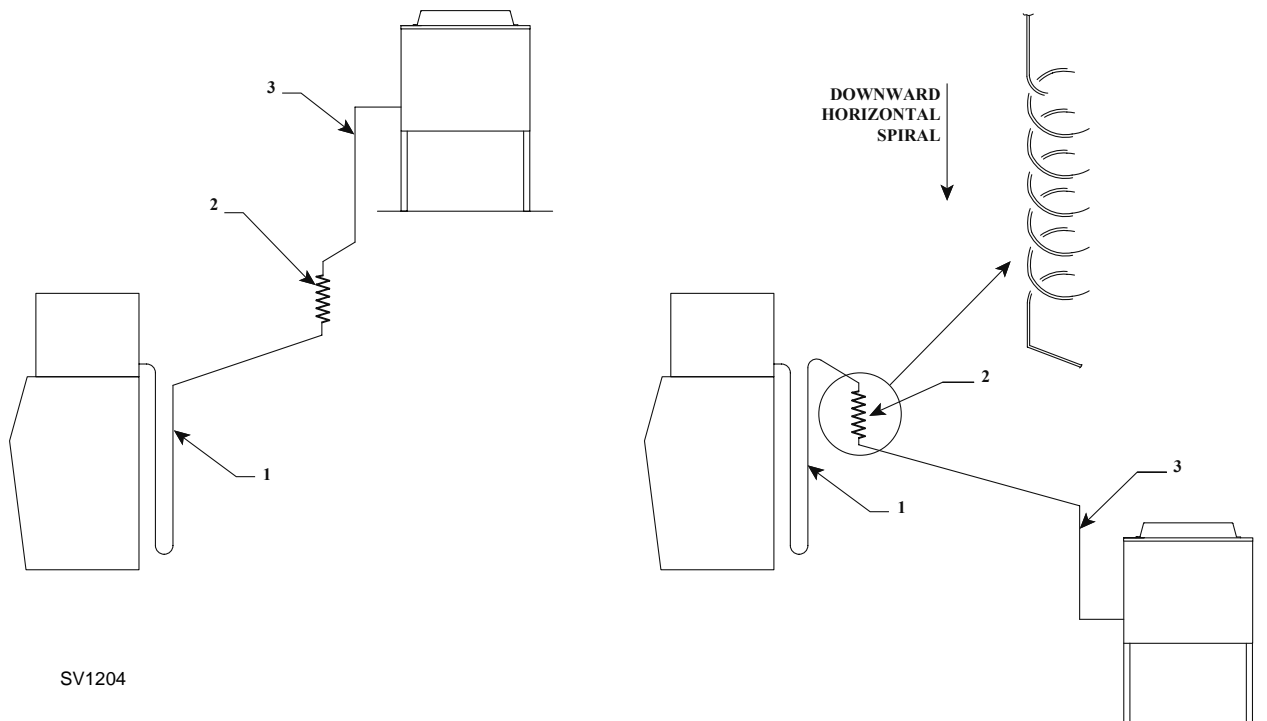

SV1204

**Figure 2-5. Routing Line Sets**

**CALCULATING REMOTE CONDENSER INSTALLATION DISTANCES**

**Line Set Length**

The maximum length is 100' (30.5 m).

The ice machine compressor must have the proper oil return. The receiver is designed to hold a charge sufficient to operate the ice machine in ambient temperatures between -20°F (-28.9°C) and 120°F (49°C), with line set lengths of up to 100' (30.5 m).

**Line Set Rise/Drop**

The maximum rise is 35' (10.7 m).

The maximum drop is 15' (4.5 m).

**⚠ Caution**

If a line set has a rise followed by a drop, another rise cannot be made. Likewise, if a line set has a drop followed by a rise, another drop cannot be made.

Make the following calculations to make sure the line set layout is within specifications.

1. Insert the **measured rise** into the formula below. Multiply by 1.7 to get the **calculated rise**. (Example: A condenser located 10 feet above the ice machine has a **calculated rise** of 17 feet.)
2. Insert the **measured drop** into the formula below. Multiply by 6.6 to get the **calculated drop**. (Example. A condenser located 10 feet below the ice machine has a **calculated drop** of 66 feet.)
3. Insert the **measured horizontal distance** into the formula below. No calculation is necessary.
4. Add together the **calculated rise**, **calculated drop**, and **horizontal distance** to get the **total calculated distance**. If this total exceeds 150' (45.7 m), move the condenser to a new location and perform the calculations again.

**Calculated Line Set Distance**

The maximum distance is 150' (45.7 m).

Line set rises, drops, horizontal runs (or combinations of these) in excess of the stated maximums will exceed compressor start-up and design limits. This will cause poor oil return to the compressor.

**Maximum Line Set Distance Formula**

|         |  |             |   |       |                           |
|---------|--|-------------|---|-------|---------------------------|
| Step 1. | Measured Rise (35' [10.7 m] Maximum)                 | _____ x 1.7 | = | _____ | Calculated Rise           |
| Step 2. | Measured Drop (15' [4.5 m] Maximum)                  | _____ x 6.6 | = | _____ | Calculated Drop           |
| Step 3. | Measured Horizontal Distance (100' [30.5 m] Maximum) |             |   | _____ | Horizontal Distance       |
| Step 4. | Total Calculated Distance 150' (45.7 m)              |             |   | _____ | Total Calculated Distance |

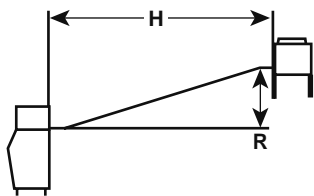

SV1196

**Figure 2-6. Combination of a Rise and a Horizontal Run**

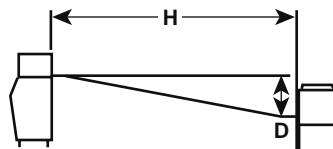

SV1195

**Figure 2-7. Combination of a Drop and a Horizontal Run**

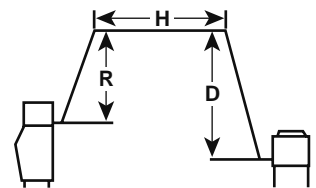

SV1194

**Figure 2-8. Combination of a Rise, a Drop and a Horizontal Run**

**LENGTHENING OR REDUCING LINE SET LENGTHS**

In most cases, by routing the line set properly, shortening will not be necessary. When shortening or lengthening is required, do so before connecting the line set to the ice machine or the remote condenser. This prevents the loss of refrigerant in the ice machine or condenser.

The quick connect fittings on the line sets are equipped with Schraeder valves. Use these valves to recover any vapor charge from the line set. When lengthening or shortening lines, follow good refrigeration practices and insulate new tubing. Do not change the tube sizes. Evacuate the lines and place about 5 oz (143g) of vapor refrigerant charge in each line.

**CONNECTING A LINE SET**

1. Remove the dust caps from the line set, condenser and ice machine.
2. Apply refrigeration oil to the threads on the quick disconnect couplers before connecting them to the condenser.
3. Carefully thread the female fitting to the condenser or ice machine by hand.
4. Tighten the couplings with a wrench until they bottom out.
5. Turn an additional 1/4 turn to ensure proper brass-to-brass seating. Torque to the following specifications:

| Liquid Line                     | Discharge Line                  |
|---------------------------------|---------------------------------|
| 10-12 ft lb.<br>(13.5-16.2 N•m) | 35-45 ft lb.<br>(47.5-61.0 N•m) |

6. Check all fittings for leaks.

**REMOTE RECEIVER SERVICE VALVE**

The receiver service valve is closed during shipment. Open the valve prior to starting the ice machine.

1. Remove the top and left side panels.
2. Remove the receiver service valve cap.
3. Backseat (open) the valve.
4. Reinstall the cap and panels.

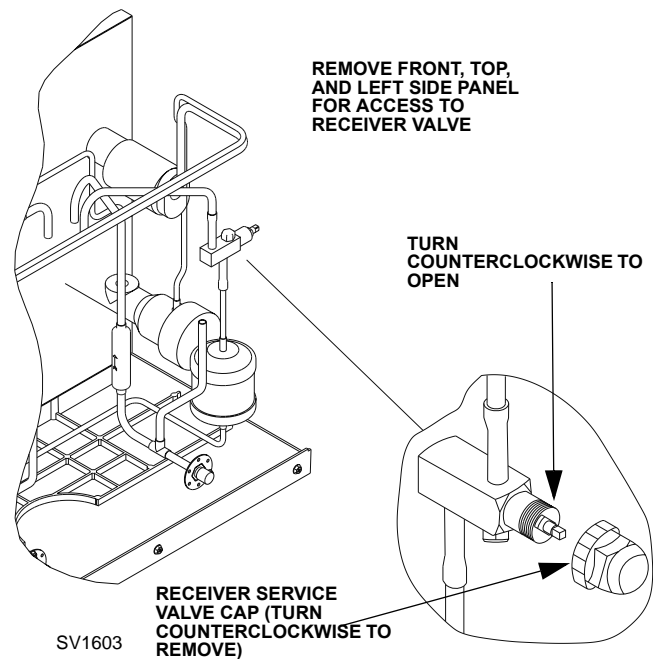

**Figure 2-9. Backseating the Receiver Service Valve**

## Remote Ice Machine Usage with Non-Manitowoc Multi-Circuit Condensers

### WARRANTY

The sixty (60) month compressor warranty, including thirty six (36) month labor replacement warranty, **shall not apply** when the remote ice machine is not installed within the remote specifications. The foregoing warranty shall not apply to any ice machine installed and/or maintained inconsistent with the technical instructions provided by Manitowoc Ice, Inc. Performance may vary from Sales specifications. Q-Model ARI certified standard ratings only apply when used with a Manitowoc remote condenser.

If the design of the condenser meets the specifications, Manitowoc's only approval is for full warranty coverage to be extended to the Manitowoc manufactured part of the system. Since Manitowoc does not test the condenser in conjunction with the ice machine, Manitowoc will not endorse, recommend, or approve the condenser, and will not be responsible for its performance or reliability..

#### Important

Manitowoc warrants only complete new and unused remote packages. Guaranteeing the integrity of a new ice machine under the terms of our warranty prohibits the use of pre-existing (used) tubing or condensers.

### HEAD PRESSURE CONTROL VALVE

Any remote condenser connected to a Manitowoc Q-Model Ice Machine must have a head pressure control valve #836809-3 (available from Manitowoc Distributors) installed on the condenser package. Manitowoc **will not accept** substitute "off the shelf" head pressure control valves.

#### Caution

Do not use a fan cycling control to try to maintain discharge pressure. Compressor failure will result.

### FAN MOTOR

The condenser fan must be **on** during the complete ice machine freeze cycle (do not cycle on fan cycle control). The ice maker has a condenser fan motor circuit for use with a Manitowoc condenser. It is recommended that this circuit be used to control the condenser fan(s) on the multi-circuit condenser to assure it is on at the proper time. **Do not exceed the rated amps for the fan motor circuit listed on the ice machine's serial tag.**

### INTERNAL CONDENSER VOLUME

The multi-circuit condenser internal volume must not be less than or exceed that used by Manitowoc (see chart on **Page 2-18**). **Do not exceed internal volume and try to add charge to compensate, as compressor failure will result.**

### CONDENSER $\Delta T$

$\Delta T$  is the difference in temperature between the condensing refrigerant and entering air. The  $\Delta T$  should be 15 to 20°F (-9.4 to -6.6°C) at the beginning of the freeze cycle (peak load conditions) and drop down to 12 to 17°F (-11.1 to -8.3°C) during the last 75% of the freeze cycle (average load conditions).

### REFRIGERANT CHARGE

Remote ice machines have the serial plate refrigerant charge (total system charge) located in the ice maker section. (Remote condensers and line sets are supplied with only a vapor charge.)

#### Caution

Never add more than nameplate charge to ice machine for any application.

### QUICK CONNECT FITTINGS

The ice machine and line sets come with quick connect fittings. It is recommended that matching quick connects (available through Manitowoc Distributors) be installed in the multi-circuit condenser, and that a vapor "holding" charge (5 oz.) of proper refrigerant be added to the condenser prior to connection of the ice machine or line set to the condenser.

NON-MANITOWOC MULTI-CIRCUIT CONDENSER SIZING CHART

| Ice Machine Model | Refrigerant |                      | Heat of Rejection |             | Internal Condenser Volume (cu ft) |       | Design Pressure                | Quick Connect Stubs-Male Ends |                               | Head Pressure Control Valve |
|-------------------|-------------|----------------------|-------------------|-------------|-----------------------------------|-------|--------------------------------|-------------------------------|-------------------------------|-----------------------------|
|                   | Type        | Charge               | Average Btu/hr    | Peak Btu/hr | Min                               | Max   |                                | Discharge                     | Liquid                        |                             |
| Q450              | R-404A      | 6 lbs.               | 7,000             | 9,600       | 0.020                             | 0.035 | 500 psig safe working pressure | coupling P/N 83-6035-3        | coupling P/N 83-6034-3        | Manitowoc P/N 83-6809-3     |
| Q600              | R-404A      | 8 lbs.               | 9,000             | 13,900      | 0.045                             | 0.060 |                                |                               |                               |                             |
| Q800              | R-404A      | 8 lbs.               | 12,400            | 19,500      | 0.045                             | 0.060 | 2,500 psig burst pressure      | mounting flange P/N 83-6006-3 | mounting flange P/N 83-6005-3 | <b>no substitutes</b>       |
| Q1000             | R-404A      | 9.5 lbs.             | 16,000            | 24,700      | 0.065                             | 0.085 |                                |                               |                               |                             |
| Q1300             | R-404A      | 14 lbs. <sup>1</sup> | 24,000            | 35,500      | 0.085                             | 0.105 |                                |                               |                               |                             |
| Q1600             | R-404A      | 17 lbs. <sup>1</sup> | 36,000            | 50,000      | 0.130                             | 0.170 |                                |                               |                               |                             |
| Q1800             | R-404A      | 17 lbs.              | 36,000            | 50,000      | 0.130                             | 0.170 |                                |                               |                               |                             |

Amount reflects additional R-404A refrigerant added to nameplate charge for 50' to 100' line sets, to ensure proper operation at all ambient conditions. Q1300 has 1.5 lbs. additional R-404A. Q1600 and Q1800 has 2.0 lbs. additional R-404A

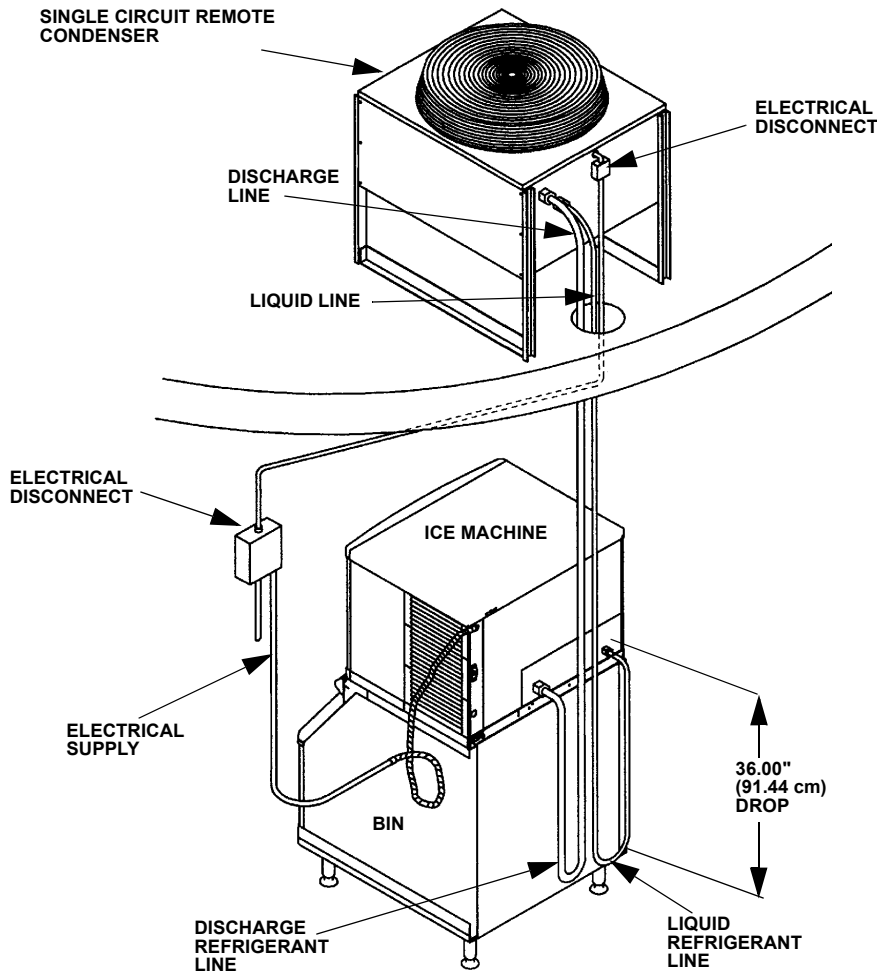

SV1615

Figure 2-10. Typical Single Circuit Remote Condenser Installation

**Installation Check List**

- |  |  |
|--|--|
| <input type="checkbox"/> Is the Ice Machine level?   | <input type="checkbox"/> Are the ice machine and bin drains vented?  |
| <input type="checkbox"/> Has all of the internal packing been removed?   | <input type="checkbox"/> Are all electrical leads free from contact with refrigeration lines and moving equipment?   |
| <input type="checkbox"/> Have all of the electrical and water connections been made?   | <input type="checkbox"/> Has the owner/operator been instructed regarding maintenance and the use of Manitowoc Cleaner and Sanitizer?  |
| <input type="checkbox"/> Has the supply voltage been tested and checked against the rating on the nameplate?   | <input type="checkbox"/> Has the owner/operator completed the warranty registration card?  |
| <input type="checkbox"/> Is there proper clearance around the ice machine for air circulation?   | <input type="checkbox"/> Has the ice machine and bin been sanitized?   |
| <input type="checkbox"/> Has the ice machine been installed where ambient temperatures will remain in the range of 35° - 110°F (1.7° - 43.3°C)?          | <input type="checkbox"/> Is the toggle switch set to ice? (The toggle switch is located directly behind the front panel).  |
| <input type="checkbox"/> Has the ice machine been installed where the incoming water temperature will remain in the range of 33° - 90°F (0.6° - 32.2°C)? | <input type="checkbox"/> Is the ice thickness control set correctly? (Refer to Operational Checks on page 3-4 of this manual to check/set the correct ice bridge thickness). |
| <input type="checkbox"/> Is there a separate drain for the water-cooled condenser?   |  |
| <input type="checkbox"/> Is the water trough drain plug installed? (The drain plug is taped to the top of the water pump).                               |  |

**Additional Checks for Remote Models**

- |  |
|--|
| <input type="checkbox"/> Has the receiver service valve been opened?   |
| <input type="checkbox"/> Does the remote condenser fan operate properly after start-up?  |
| <input type="checkbox"/> Has the remote condenser been located where ambient temperatures will remain in the range of -20° - 120°F ( -6.6 - 49°C). |
| <input type="checkbox"/> Is the line set routed properly?  |

THIS PAGE INTENTIONALLY LEFT BLANK



# Section 3 Ice Machine Operation

## Component Identification

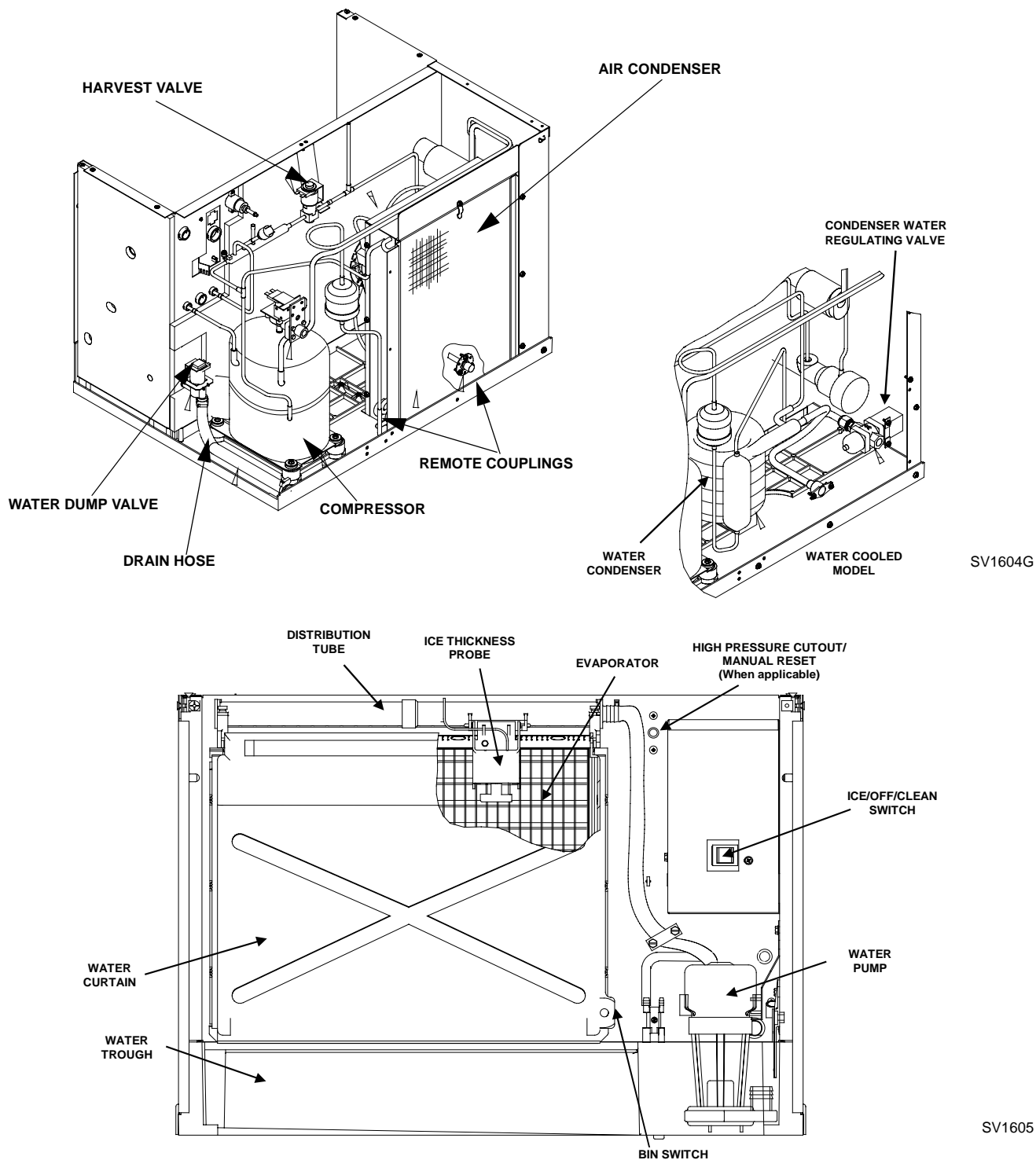

**Figure 3-1. Component Identification (Typical Q450 Shown)**

## Self-Contained Air- and Water-Cooled Q200/Q280/Q320/Q370/Q420/Q450/Q600/Q800/Q1000/Q1300/Q1600/Q1800

### INITIAL START-UP OR START-UP AFTER AUTOMATIC SHUT-OFF

#### 1. Water Purge

Before the compressor starts, the water pump and water dump solenoid are energized for 45 seconds, to completely purge the ice machine of old water. This feature ensures that the ice making cycle starts with fresh water.

The harvest valve(s) is also energized during water purge, although it stays on for an additional 5 seconds (50 seconds total on time) during the initial refrigeration system start-up.

#### 2. Refrigeration System Start-Up

The compressor starts after the 45 second water purge, and it remains on throughout the entire Freeze and Harvest Sequences. The water fill valve is energized at the same time as the compressor. It remains on until the water level sensor closes for 3 continuous seconds, or until a six-minute time period has expired. The harvest valve(s) remains on for 5 seconds during initial compressor start-up and then shuts off.

At the same time the compressor starts, the condenser fan motor (air-cooled models) is supplied with power throughout the entire Freeze and Harvest Sequences. The fan motor is wired through a fan cycle pressure control, therefore it may cycle on and off. (The compressor and condenser fan motor are wired through the contactor. As a result, anytime the contactor coil is energized, the compressor and fan motor are supplied with power.)

### FREEZE SEQUENCE

#### 3. Prechill

The compressor is on for 30 seconds prior to water flow, to prechill the evaporator.

#### 4. Freeze

The water pump restarts after the 30 second prechill. An even flow of water is directed across the evaporator and into each cube cell, where it freezes. The water fill valve will cycle on and then off one more time to refill the water trough.

When sufficient ice has formed, the water flow (not the ice) contacts the ice thickness probe. After approximately 7 seconds of continual water contact, the harvest sequence is initiated. The ice machine cannot initiate a harvest sequence until a 6 minute freeze lock has been surpassed.

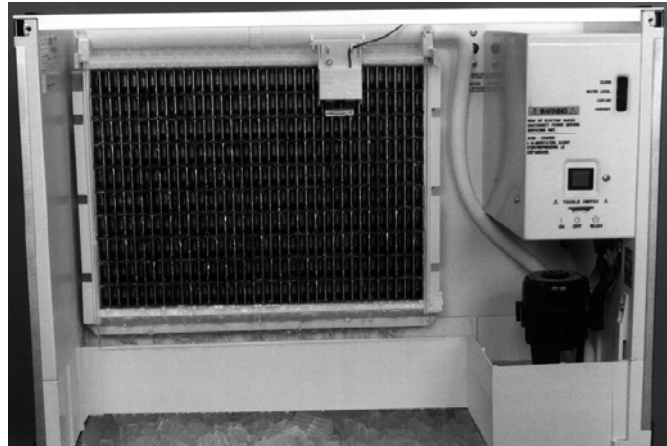

**Figure 3-2. Freeze Sequence  
(Typical Q450 Shown)**

Continued on next page ...

## HARVEST SEQUENCE

### 5. Water Purge

The water pump continues to run, and the water dump valve energizes for 45 seconds to purge the water in the sump trough. The water fill valve energizes (turns on) and de-energizes (turns off) strictly by time. The water fill valve energizes for the last 15 seconds of the 45-second water purge. The water purge must be at the factory setting of 45 seconds for the fill valve to energize during the last 15 seconds of the Water Purge. If set at less than 45 seconds the water fill valve does not energize during the water purge.

After the 45 second water purge, the water fill valve, water pump and dump valve de-energize. (Refer to "Water Purge Adjustment" for details.) The harvest valve also opens at the beginning of the water purge to divert hot refrigerant gas into the evaporator.

### 6. Harvest

The harvest valve(s) remains open and the refrigerant gas warms the evaporator causing the cubes to slide, as a sheet, off the evaporator and into the storage bin. The sliding sheet of cubes swings the water curtain out, opening the bin switch. The momentary opening and re-closing of the bin switch terminates the harvest sequence and returns the ice machine to the freeze sequence (Step 3 - 4.)

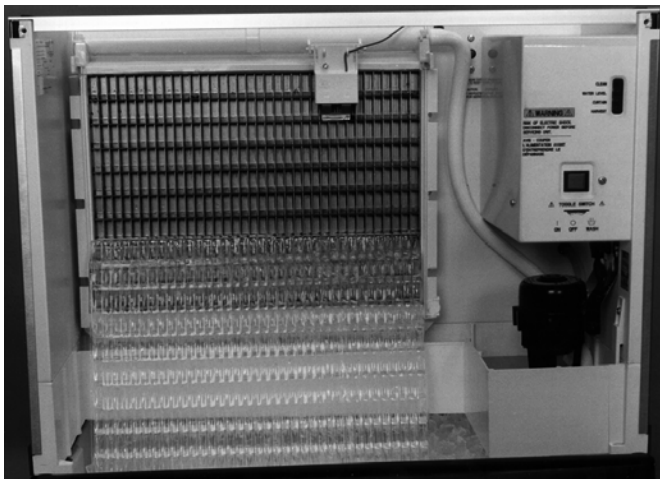

Figure 3-3. Harvest Sequence (Typical Q450 Shown)

## AUTOMATIC SHUT-OFF

### 7. Automatic Shut-Off

When the storage bin is full at the end of a harvest sequence, the sheet of cubes fails to clear the water curtain and will hold it open. After the water curtain is held open for 7 seconds, the ice machine shuts off. The ice machine remains off for 3 minutes before it can automatically restart.

The ice machine remains off until enough ice has been removed from the storage bin to allow the ice to fall clear of the water curtain. As the water curtain swings back to the operating position, the bin switch re-closes and the ice machine restarts (steps 1 - 2), provided the 3 minute delay period is complete.

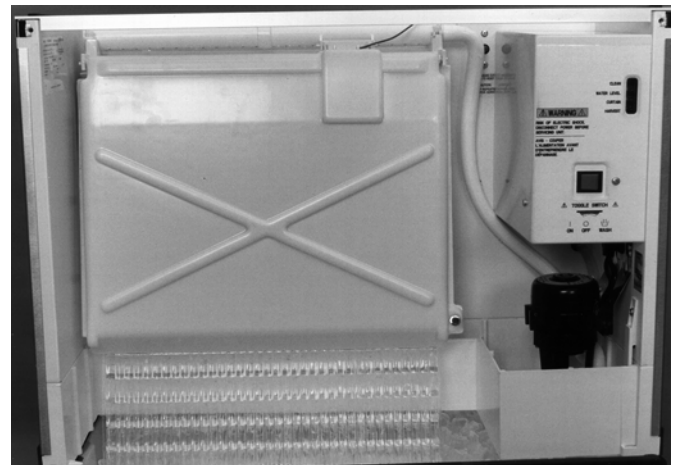

Figure 3-4. Automatic Shut-Off (Typical Q450 Shown)

## Remote Q450/Q600/Q800/Q1000/Q1300/Q1600/Q1800

### INITIAL START-UP OR START-UP AFTER AUTOMATIC SHUT-OFF

#### 1. Water Purge

Before the compressor starts, the water pump and water dump solenoid are energized for 45 seconds, to completely purge the ice machine of old water. This feature ensures that the ice making cycle starts with fresh water.

The harvest valve and harvest pressure regulating (HPR) solenoid valves also energize during water purge, although they stay on for an additional 5 seconds (50 seconds total on time) during the initial refrigeration system start-up.

#### 2. Refrigeration System Start-Up

The compressor and liquid line solenoid valve energize after the 45 second water purge and remain on throughout the entire Freeze and Harvest Sequences. The water fill valve is energized at the same time as the compressor. It remains on until the water level sensor closes for 3 continuous seconds, or until a six-minute time period has expired. The harvest valve and HPR solenoid valves remain on for 5 seconds during initial compressor start-up and then shut off.

The remote condenser fan motor starts at the same time the compressor starts and remains on throughout the entire Freeze and Harvest Sequences. (The compressor and condenser fan motor are wired through the contactor, therefore, anytime the contactor coil is energized, the compressor and fan motor are on.)

### FREEZE SEQUENCE

#### 3. Prechill

The compressor is on for 30 seconds prior to water flow, to prechill the evaporator.

#### 4. Freeze

The water pump restarts after the 30 second prechill. An even flow of water is directed across the evaporator and into each cube cell, where it freezes. The water fill valve will cycle on and then off one more time to refill the water trough.

When sufficient ice has formed, the water flow (not the ice) contacts the ice thickness probe. After approximately 7 seconds of continual water contact, the harvest sequence is initiated. The ice machine cannot initiate a harvest sequence until a 6 minute freeze lock has been surpassed.

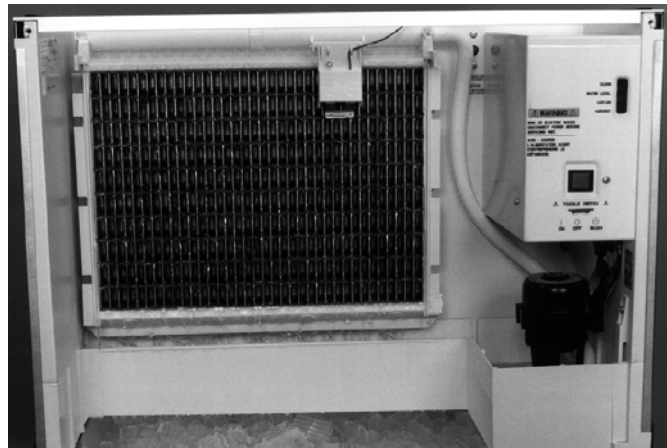

**Figure 3-5. Freeze Sequence (Typical Q450 Shown)**

Continued on next page ...

## HARVEST SEQUENCE

### 5. Water Purge

The water pump continues to run, and the water dump valve energizes for 45 seconds to purge the water in the sump trough. The water fill valve energizes (turns on) and de-energizes (turns off) strictly by time. The water fill valve energizes for the last 15 seconds of the 45-second water purge. The water purge must be at the factory setting of 45 seconds for the fill valve to energize during the last 15 seconds of the Water Purge. If set at less than 45 seconds the water fill valve does not energize during the water purge.

After the 45 second water purge, the water fill valve, water pump and dump valve de-energize. (Refer to "Water Purge Adjustment" for details.) The harvest valve(s) and HPR solenoid valve also open at the beginning of the water purge.

### 6. Harvest

The HPR valve and the harvest valve(s) remain open and the refrigerant gas warms the evaporator causing the cubes to slide, as a sheet, off the evaporator and into the storage bin. The sliding sheet of cubes swings the water curtain out, opening the bin switch. The momentary opening and re-closing of the bin switch terminates the harvest sequence and returns the ice machine to the freeze sequence (Step 3 - 4.)

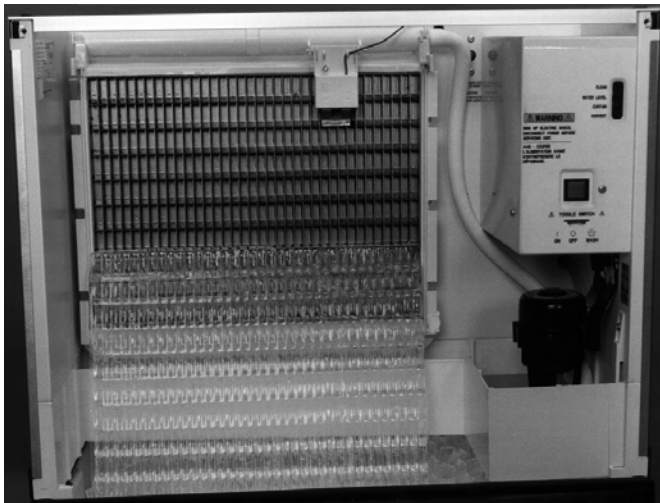

Figure 3-6. Harvest Sequence (Typical Q450 Shown)

## AUTOMATIC SHUT-OFF

### 7. Automatic Shut-Off

When the storage bin is full at the end of a harvest sequence, the sheet of cubes fails to clear the water curtain and will hold it open. After the water curtain is held open for 7 seconds, the ice machine shuts off. The ice machine remains off for 3 minutes before it can automatically restart.

The ice machine remains off until enough ice has been removed from the storage bin to allow the ice to drop clear of the water curtain. As the water curtain swings back to the operating position, the bin switch re-closes and the ice machine restarts (steps 1 - 2) provided the 3 minute delay period is complete.

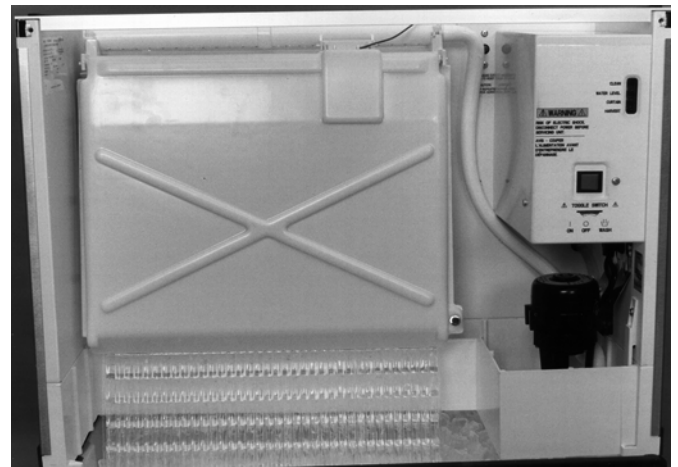

Figure 3-7. Automatic Shut-Off (Typical Q450 Shown)

## Operational Checks

### GENERAL

Manitowoc ice machines are factory-operated and adjusted before shipment. Normally, new installations do not require any adjustment.

To ensure proper operation, always follow the Operational Checks:

- when starting the ice machine for the first time
- after a prolonged out of service period
- after cleaning and sanitizing

NOTE: Routine adjustments and maintenance procedures are not covered by the warranty.

### WATER LEVEL

The water level sensor is set to maintain the proper water level above the water pump housing. The water level is not adjustable.

If the water level is incorrect, check the water level probe for damage (probe bent, etc.). Repair or replace the probe as necessary.

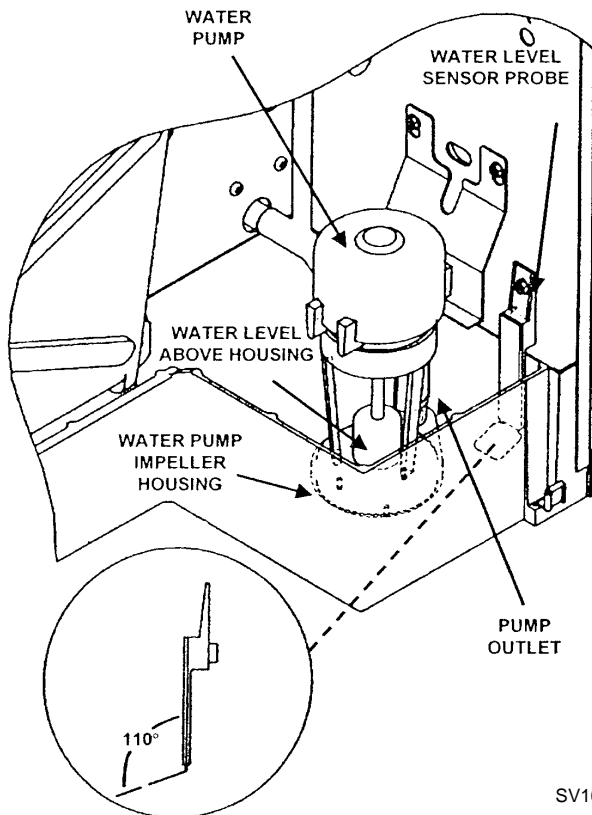

SV1616

Figure 3-8. Water Level Probe

### ICE THICKNESS CHECK

The ice thickness probe is factory-set to maintain the ice bridge thickness at 1/8" (3.2 mm).

NOTE: Make sure the water curtain is in place when performing this check. It prevents water from splashing out of the water trough.

1. Inspect the bridge connecting the cubes. It should be about 1/8" (3.2 mm) thick.
2. If adjustment is necessary, turn the ice thickness probe adjustment screw clockwise to increase bridge thickness, counterclockwise to decrease bridge thickness.

NOTE: Turning the adjustment 1/3 of a turn will change the ice thickness about 1/16" (1.5 mm).

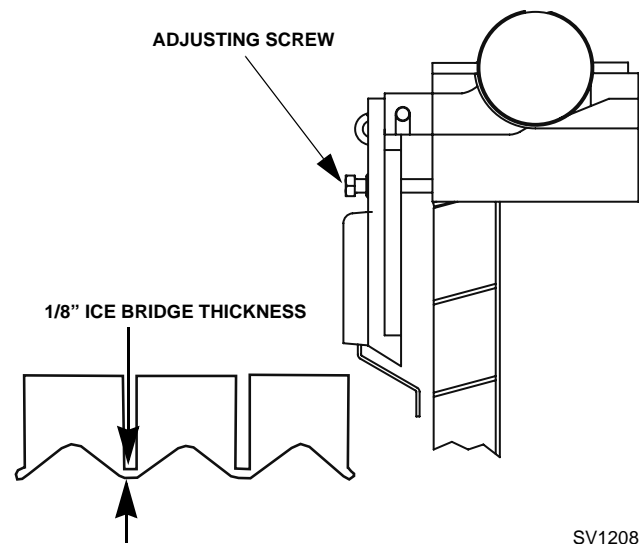

SV1208

Figure 3-9. Ice Thickness Check

3. Make sure the ice thickness probe wire and the bracket do not restrict movement of the probe.

**HARVEST SEQUENCE WATER PURGE**

The harvest sequence water purge adjustment may be used when the ice machine is hooked up to special water systems, such as a de-ionized water treatment system.

**Important**

The harvest sequence water purge is factory-set at 45 seconds. A shorter purge setting (with standard water supplies such as city water) is not recommended. This can increase water system cleaning and sanitizing requirements.

- The harvest sequence water purge may be set to 15, 30, or 45 seconds.
- During the harvest sequence water purge, the water fill valve energizes and de-energizes by time. The water purge must be at the factory setting of 45 seconds for the water fill valve to energize during the last 15 seconds of the water purge. If it is set to less than 45 seconds, the water fill valve will not energize during the water purge.

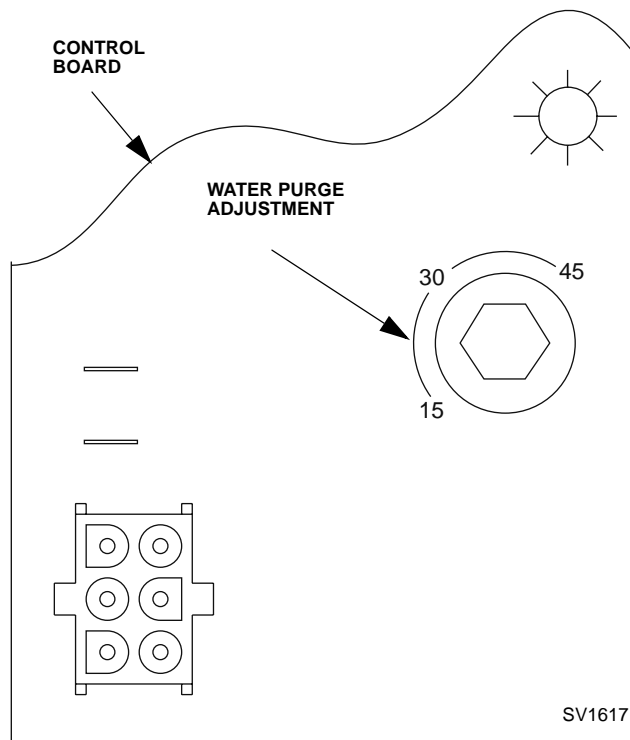

**Figure 3-10. Water Purge Adjustment**

THIS PAGE INTENTIONALLY LEFT BLANK



## Section 4 Maintenance

### Interior Cleaning and Sanitizing

#### GENERAL

Clean and sanitize the ice machine every six months for efficient operation. If the ice machine requires more frequent cleaning and sanitizing, consult a qualified service company to test the water quality and recommend appropriate water treatment. The ice machine must be taken apart for cleaning and sanitizing.

**⚠ Caution**

Use only Manitowoc approved Ice Machine Cleaner and Sanitizer for this application (Manitowoc Cleaner part number 94-0546-3 and Manitowoc Sanitizer part number 94-0565-3). It is a violation of Federal law to use these solutions in a manner inconsistent with their labeling. Read and understand all labels printed on bottles before use.

#### CLEANING PROCEDURE

**⚠ Caution**

Do not mix Cleaner and Sanitizer solutions together. It is a violation of Federal law to use these solutions in a manner inconsistent with their labeling.

**⚠ Warning**

Wear rubber gloves and safety goggles (and/or face shield) when handling ice machine Cleaner or Sanitizer.

Ice machine cleaner is used to remove lime scale and mineral deposits. Ice machine sanitizer disinfects and removes algae and slime.

**Step 1** Set the toggle switch to the OFF position after ice falls from the evaporator at the end of a Harvest cycle. Or, set the switch to the OFF position and allow the ice to melt off the evaporator.

**⚠ Caution**

Never use anything to force ice from the evaporator. Damage may result.

**Step 2** Remove top cover. This will allow easiest access for adding cleaning and sanitizing solutions.

**Step 3** Remove all ice from the bin.

**Step 4** Place the toggle switch in the CLEAN position. The water will flow through the water dump valve and down the drain. Wait until the water trough refills and water flows over the evaporator, then add the proper amount of ice machine cleaner.

| Model                   | Amount of Cleaner |
|-------------------------|-------------------|
| Q200/Q280/Q322/Q370     | 3 ounces (90 ml)  |
| Q422/Q450/Q600/Q800     | 5 ounces (150 ml) |
| Q1000/Q1300/Q1400/Q1800 | 9 ounces (265 ml) |

**Step 5** Wait until the clean cycle is complete (approximately 30 minutes) then place the toggle switch in the OFF position and disconnect power to the ice machine (and dispenser when used).

**⚠ Warning**

Disconnect the electric power to the ice machine at the electric service switch box..

**Step 6** Remove parts for cleaning and hand sanitizing.

**A. Remove the water curtain**

- Gently flex the curtain in the center and remove it from the right side.
- Slide the left pin out.

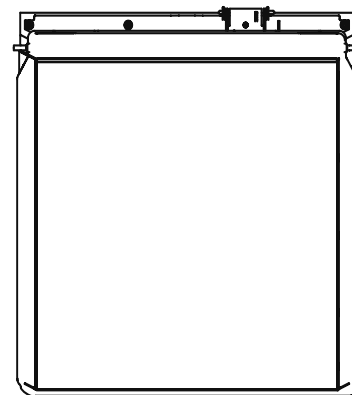

**Water Curtain Removal**

**B. Remove the ice thickness probe**

- Compress the hinge pin on the top of the ice thickness probe.

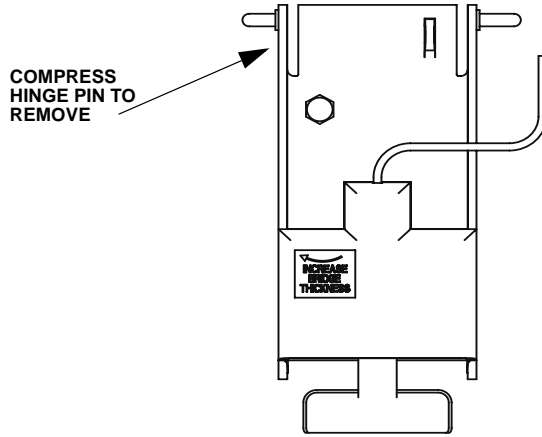

SV3135

**Ice Thickness Probe Removal**

- Pivot the ice thickness probe to disengage one pin then the other. The ice thickness probe can be cleaned and sanitized at this point without complete removal. If complete removal is desired, disconnect the ice thickness control wiring from the control board.

**C. Remove the water distribution tube**

- Disconnect the water hose from the distribution tube.

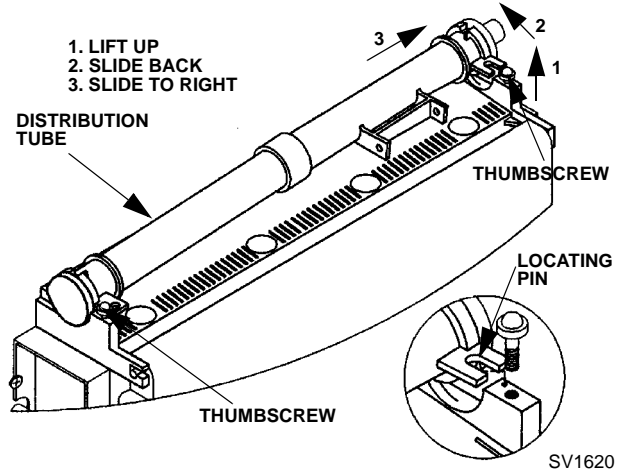

**Water Distribution Tube Removal**

- Loosen the two thumbscrews which secure the distribution tube.
- Lift the right side of the distribution tube up off the locating pin, then slide it back and to the right.

**⚠ Caution**

Do not force this removal. Be sure the locating pin is clear of the hole before sliding the distribution tube out.

Disassemble for cleaning/sanitizing.

- Twist both of the inner tube ends until the tabs line up with the keyways.
- Pull the inner tube ends outward.

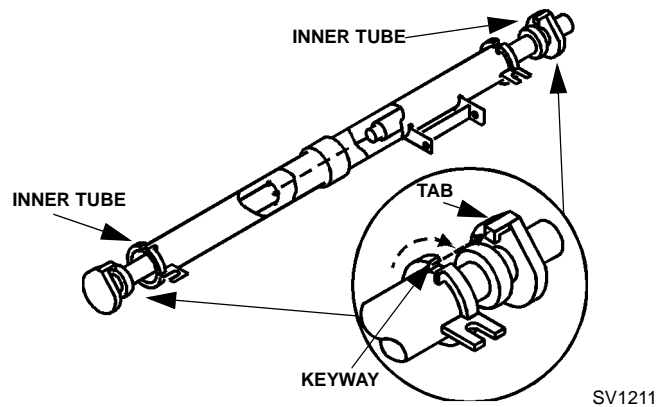

**Water Distribution Tube Disassembly**

**D. Remove the white vinyl water distribution tubing**

- Disconnect the hose from the water pump outlet.
- Disconnect the hose from the dump valve (the tubing pressure fits - pull tubing into evaporator compartment).

**E. Remove the water pump**

- Disconnect the water pump power cord.

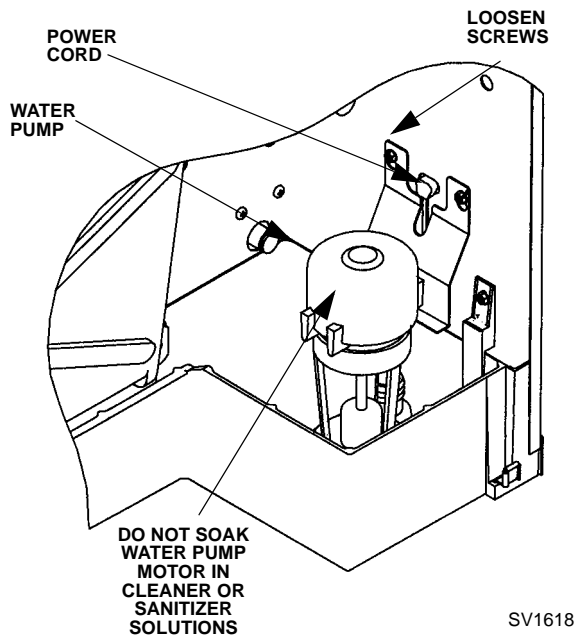

**Water Pump Removal**

- Loosen the screws securing the pump mounting bracket to the bulkhead.
- Lift the pump and bracket assembly off the screws.

**F. Remove the water level probe**

- Loosen the screw that holds the water level probe in place. The probe can easily be cleaned and sanitized at this point without proceeding to step 2.
- If complete removal is required, disconnect the wire lead from the control board inside the electrical control box.

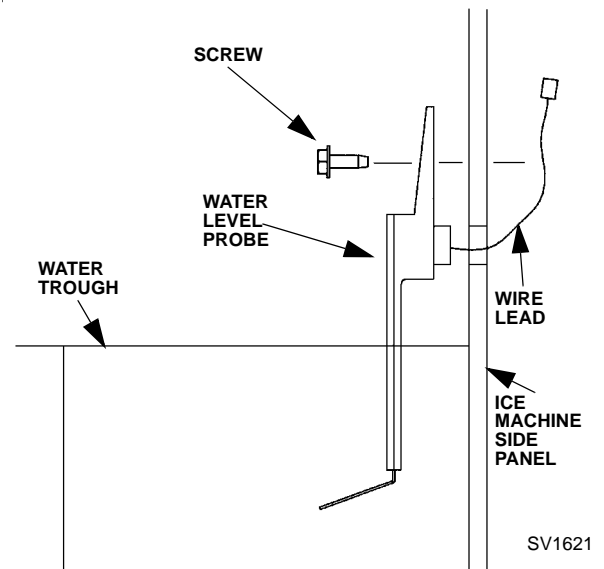

**Water Level Probe Removal**

**Step 7** Mix a solution of cleaner and warm water. Depending upon the amount of mineral buildup, a larger quantity of solution may be required. Use the ratio in the table below to mix enough solution to thoroughly clean all parts.

| Solution Type | Water        | Mixed With             |
|---------------|--------------|------------------------|
| Cleaner       | 1 gal. (4 l) | 16 oz (500 ml) cleaner |

**Step 8** Use 1/2 of the cleaner/water mixture to clean all components. The cleaner solution will foam when it contacts lime scale and mineral deposits; once the foaming stops use a soft-bristle nylon brush, sponge or cloth (NOT a wire brush) to carefully clean the parts. Soak parts for 5 minutes (15 - 20 minutes for heavily scaled parts). Rinse all components with clean water.

**Step 9** While components are soaking, use 1/2 of the cleaner/water solution to clean all foodzone surfaces of the ice machine and bin (or dispenser). Use a nylon brush or cloth to thoroughly clean the following ice machine areas:

- Side walls
- Base (bottom of the water trough)
- Interior of the water trough
- Evaporator cells and evaporator plastic parts - including top, bottom, and sides
- Bin or dispenser
- Ice machine top cover

Remove water trough drain plug and rinse all areas thoroughly with clean water. Reinstall water trough drain plug.

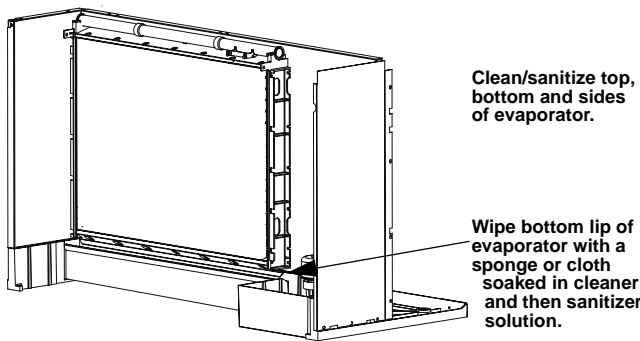

**Step 10** Mix a solution of sanitizer and warm water.

| Solution Type | Water         | Mixed With              |
|---------------|---------------|-------------------------|
| Sanitizer     | 6 gal. (23 l) | 4 oz (120 ml) sanitizer |

**Step 11** Use 1/2 of the sanitizer/water solution to sanitize all removed components. Use a cloth or sponge to liberally apply the solution to all surfaces of the removed parts or soak the removed parts in the sanitizer/water solution. Do not rinse parts after sanitizing.

**Step 12** Use 1/2 of the sanitizer/water solution to sanitize all foodzone surfaces of the ice machine and bin (or dispenser). Use a cloth or sponge to liberally apply the solution. Wipe all surfaces twice to ensure complete coverage with sanitizer solution. When sanitizing, pay particular attention to the following areas:

- Side walls
- Base (bottom of the water trough)
- Interior of water trough
- Evaporator cells and evaporator plastic parts - including top, bottom and sides
- Bin or dispenser
- Ice machine top cover

Do not rinse the sanitized areas. Remove the water trough drain plug and wipe with solution. When the sanitizer solution has drained from the trough, reinstall the water trough drain plug.

**Step 13** Replace all removed components.

**Step 14** Reapply power to the ice machine and place the toggle switch in the CLEAN position.

**Step 15** Wait about two minutes or until water starts to flow over the evaporator. Add the proper amount of Manitowoc Ice Machine Sanitizer to the water trough by pouring between the water curtain and evaporator.

| Model   | Amount of Sanitizer  |
|---|----------------------|
| Q200 Q280 Q322 Q370<br>Q422 Q450 Q600 Q800<br>Q1000 | 3 ounces (90 ml)     |
| Q1300 Q1600 Q1800                                   | 8.75 ounces (258 ml) |

**Step 16** The ice machine will stop after the sanitize cycle (approximately 30 minutes). Place the toggle switch in the OFF position and disconnect power to the ice machine.

 **Warning**

Disconnect the electric power to the ice machine at the electric service switch box..

**Step 17** Repeat step 6 for hand sanitizing.

**Step 18** Mix a solution of sanitizer and warm water.

| Solution Type | Water         | Mixed With              |
|---------------|---------------|-------------------------|
| Sanitizer     | 6 gal. (23 l) | 4 oz (120 ml) sanitizer |

**Step 19** Use 1/2 of the sanitizer/water solution to sanitize all removed components. Use a cloth or sponge to liberally apply the solution to all surfaces of the removed parts or soak the removed parts in the sanitizer/water solution. Do not rinse parts after sanitizing.

**Step 20** Use 1/2 of the sanitizer/water solution to sanitize all foodzone surfaces of the ice machine and bin (or dispenser). Use a cloth or sponge to liberally apply the solution. When sanitizing, pay particular attention to the following areas:

- Side walls
- Base (bottom of the water trough)
- Interior of water trough
- Evaporator cells and evaporator plastic parts - including top, bottom and sides
- Bin or dispenser
- Ice machine top cover

Do not rinse the sanitized areas. Remove the water trough drain plug and wipe with solution. When the sanitizer solution has drained from the trough, reinstall the water trough drain plug.

**Step 21** Install the removed parts, restore power and place the toggle switch in the ICE position.

**ADDITIONAL COMPONENT REMOVAL**

The following components may be removed for easier access in some installations or they may need to be removed and cleaned to correct an operational problem.

**Water Inlet Valve**

The water inlet valve normally does not require removal for cleaning. Refer to Section 5 for a list of causes for “No Water Entering Water Trough” or “Water Overflows Water Trough.”

1. When the ice machine is off, the water inlet valve must completely stop water flow into the machine.
2. When the ice machine is on, the water inlet valve must allow the proper water flow through it. Set the toggle switch to ON. Watch for water flow into the ice machine. If the water flow is slow or only trickles into the ice machine, refer to Section 5.

Follow the procedure below to remove the water inlet valve.

**Warning**

Disconnect the electric power to the ice machine and dispenser at the electric service switch box and turn off the water supply before proceeding.

1. Remove the 1/4" hex head screws.
2. Remove, clean, and install the filter screen.

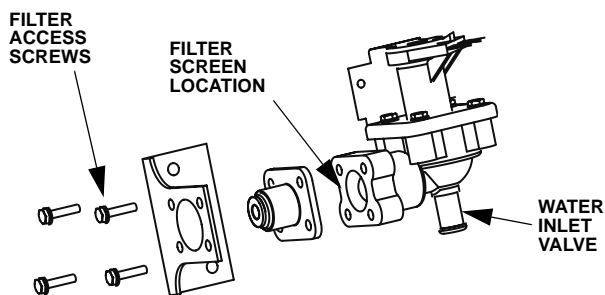
**Water Dump Valve**

The water dump valve normally does not require removal for cleaning. To determine if removal is necessary:

1. Set the toggle switch to ICE.
2. Verify the water trough fills with water at the beginning of the freeze cycle.
3. While the ice machine is in the freeze mode, check the water trough to determine if the dump valve is leaking. If there is no or little water in the water trough (during the freeze cycle) the dump valve is leaking.
  - A. If the dump valve is leaking, remove, disassemble and clean it.
  - B. If the dump valve is not leaking, do not remove it. Instead, follow the “Ice Machine Cleaning Procedure”.

Follow the procedure below to remove the dump valve.

**Warning**

Disconnect the electric power to the ice machine at the electric service switch box and turn off the water supply before proceeding.

1. Leaving the wires attached, twist coil and rotate it counter-clockwise 1/4 turn.
2. Lift the coil assembly off the valve body.
3. Remove the spring, plunger, and nylon gasket from the valve body.

**NOTE:** At this point, the water dump valve can easily be cleaned. If complete removal is desired, continue with step 4.

**NOTE:** During cleaning, do not stretch or damage the spring.

4. Remove the tubing from the dump valve by twisting the clamps off.
5. Twist the valve body to remove from mounting bracket.

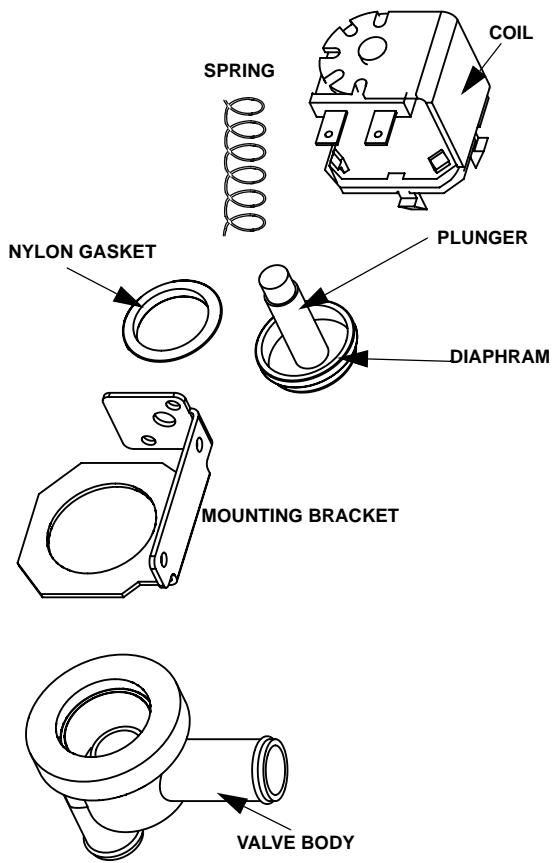

**Dump Valve Disassembly**

## Ice Machine Inspection

Check all water fittings and lines for leaks. Also, make sure the refrigeration tubing is not rubbing or vibrating against other tubing, panels, etc.

Do not put anything (boxes, etc.) on the sides or back of the ice machine. There must be adequate airflow through and around the ice machine to maximize ice production and ensure long component life.

## Exterior Cleaning

Clean the area around the ice machine as often as necessary to maintain cleanliness and efficient operation. Use cleaners designed for use with stainless steel products.

Sponge any dust and dirt off the outside of the ice machine with mild soap and water. Wipe dry with a clean, soft cloth.

Heavy stains should be removed with stainless steel wool. Never use plain steel wool or abrasive pads. They will scratch the panels.

## Cleaning the Condenser

### GENERAL

#### **Warning**

Disconnect electric power to the ice machine head section and the remote condensing unit at the electric service switches before cleaning the condenser.

A dirty condenser restricts airflow, resulting in excessively high operating temperatures. This reduces ice production and shortens component life. Clean the condenser at least every six months. Follow the steps below.

#### **Warning**

The condenser fins are sharp. Use care when cleaning them.

1. The washable aluminum filter on self-contained ice machines is designed to catch dust dirt lint and grease. Clean the filter with a mild soap and water.
2. Clean the outside of the condenser with a soft brush or a vacuum with a brush attachment. Be careful not to bend the condenser fins.
3. Shine a flashlight through the condenser to check for dirt between the fins. If dirt remains:
  - A. Blow compressed air through the condenser fins from the inside. Be careful not to bend the fan blades.
  - B. Use a commercial condenser coil cleaner. Follow the directions and cautions supplied with the cleaner.



4. Straighten any bent condenser fins with a fin comb.

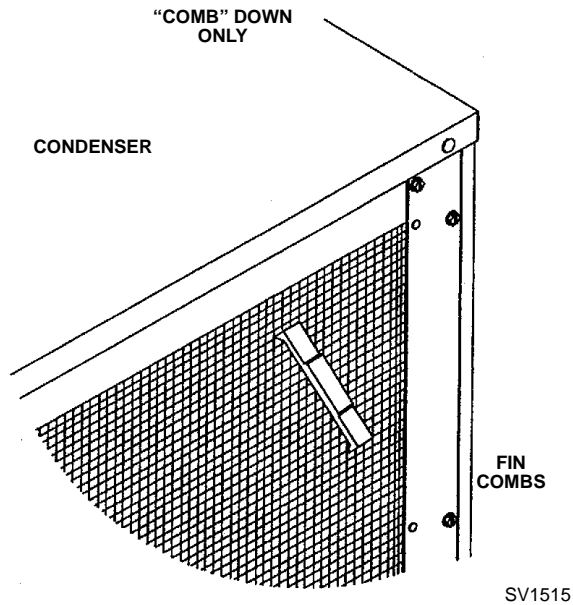

#### Straighten Bent Condenser Fins

5. Carefully wipe off the fan blades and motor with a soft cloth. Do not bend the fan blades. If the fan blades are excessively dirty, wash with warm, soapy water and rinse thoroughly.

#### Caution

If you are cleaning the condenser fan blades with water, cover the fan motor to prevent water damage and disconnect electrical power.

### Water-Cooled Condenser and Water Regulating Valve

Symptoms of restrictions in the condenser water circuit include:

- Low ice production
- High water consumption
- High operating temperatures
- High operating pressures

If the ice machine is experiencing any of these symptoms, the water-cooled condenser and water regulating valve may require cleaning due to scale build-up.

Because the cleaning procedures require special pumps and cleaning solutions, qualified maintenance or service personnel must perform them.

### AlphaSan®

The goal of AlphaSan® is to keep the plastic surfaces of an ice machine cleaner, by reducing or delaying the formation of bio-film. The active ingredient in AlphaSan® is the element silver in the form of silver ions (Ag<sup>+</sup>). AlphaSan® slowly releases silver ions via an ion exchange mechanism. When AlphaSan® is compounded directly into a plastic part, a controlled release of silver ions from the surface is regulated to maintain an effective concentration at or near the surface of the plastic ice machine part. AlphaSan's® unique ability to effectively control the release of silver not only protects against undesired discoloration of the plastic, but also will last the life of the plastic part. Although AlphaSan® helps prevent bio-film build up it does not eliminate the need for periodic cleaning and maintenance. AlphaSan® has no adverse effect on the taste of the ice or beverage.

## Removal from Service/Winterization

### GENERAL

Special precautions must be taken if the ice machine is to be removed from service for an extended period of time or exposed to ambient temperatures of 32°F (0°C) or below.

#### **Caution**

If water is allowed to remain in the ice machine in freezing temperatures, severe damage to some components could result. Damage of this nature is not covered by the warranty.

Follow the applicable procedure below.

### SELF-CONTAINED AIR-COOLED ICE MACHINES

1. Disconnect the electric power at the circuit breaker or the electric service switch.
2. Turn off the water supply.
3. Remove the water from the water trough.
4. Disconnect and drain the incoming ice-making water line at the rear of the ice machine.
5. Energize the ice machine and wait one minute for the water inlet valve to open.
6. Blow compressed air in both the incoming water and the drain openings in the rear of the ice machine until no more water comes out of the inlet water lines or the drain.
7. Make sure water is not trapped in any of the water lines, drain lines, distribution tubes, etc.

### WATER-COOLED ICE MACHINES

1. Perform steps 1-6 under "Self-Contained Air-Cooled Ice Machines."
2. Disconnect the incoming water and drain lines from the water-cooled condenser.
3. Insert a large screwdriver between the bottom spring coils of the water regulating valve. Pry upward to open the valve.

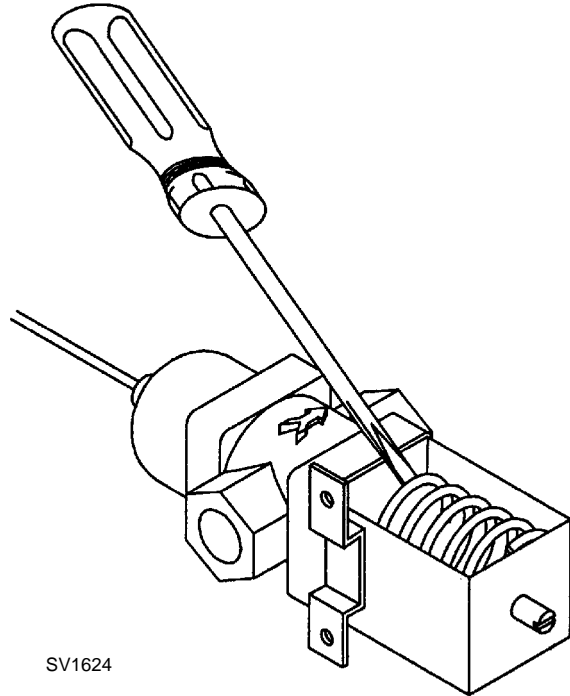

SV1624

#### **Pry Open the Water Regulating Valve**

4. Hold the valve open and blow compressed air through the condenser until no water remains.

### REMOTE ICE MACHINES

1. Move the ICE/OFF/CLEAN switch to OFF.
2. "Frontseat" (shut off) the receiver service valves. Hang a tag on the switch as a reminder to open the valves before restarting.
3. Perform steps 1-6 under "Self-Contained Air-Cooled Ice Machines."

## Section 5

# Water System Ice Making Sequence of Operation

NOTE: The sequence of operation is the same for self-contained and remote models.

### INITIAL START-UP OR START-UP AFTER AUTOMATIC SHUT-OFF

1. Before the ice machine starts, the water pump and water dump solenoid are energized for 45 seconds to purge old water from the water trough. This ensures that the ice-making cycle starts with fresh water. The water fill valve energizes after the 45-second water purge, and remains on until the water level probe is satisfied.

### FREEZE CYCLE

2. To pre-chill the evaporator, there is no water flow over the evaporator for the first 30 seconds of the freeze cycle.

3. The water pump starts after the 30-second pre-chill. An even flow of water is directed across the evaporator and into each cube cell.

During the first 45 seconds of the Freeze Cycle, the water fill valve cycles on and off as many times as needed to refill the water trough.

After the 45 seconds, the water fill valve cycles on and off one more time to refill the water trough. The water fill valve then remains off for the duration of the Freeze Cycle.

### WATER INLET VALVE SAFETY SHUT-OFF

This feature limits the water inlet valve to a six-minute on time. Regardless of the water level probe input, the control board automatically shuts off the water inlet valve if it remains on for 6 continuous minutes.

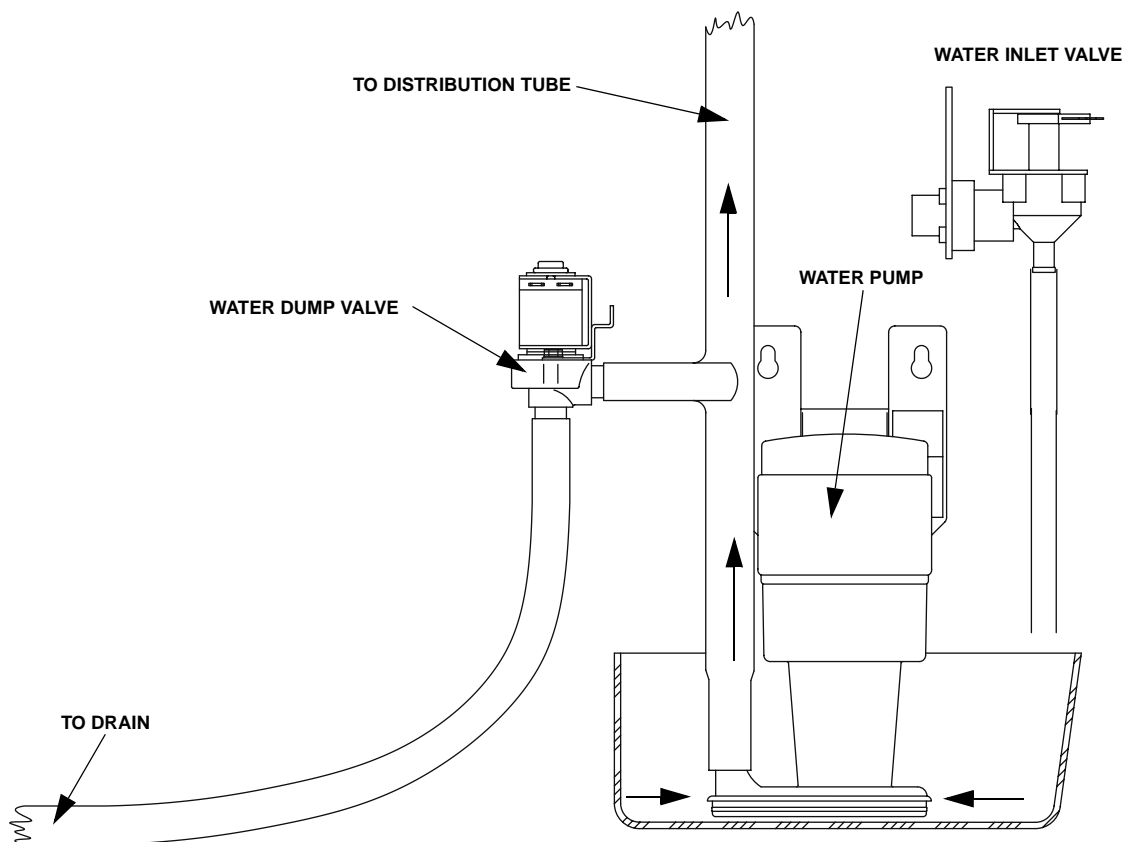

SV1677

Figure 5-1. Water Flow Over the Evaporator

**HARVEST CYCLE**

4. The water pump and water dump solenoid are energized for 45 seconds to purge the water from the water trough. The water fill valve energizes for the last 15 seconds of the 45-second purge cycle, to flush sediment from the bottom of the water trough.
5. After the 45-second purge, the water pump and water dump valve de-energize.

**AUTOMATIC SHUT-OFF**

There is no water flow during an automatic shut-off.

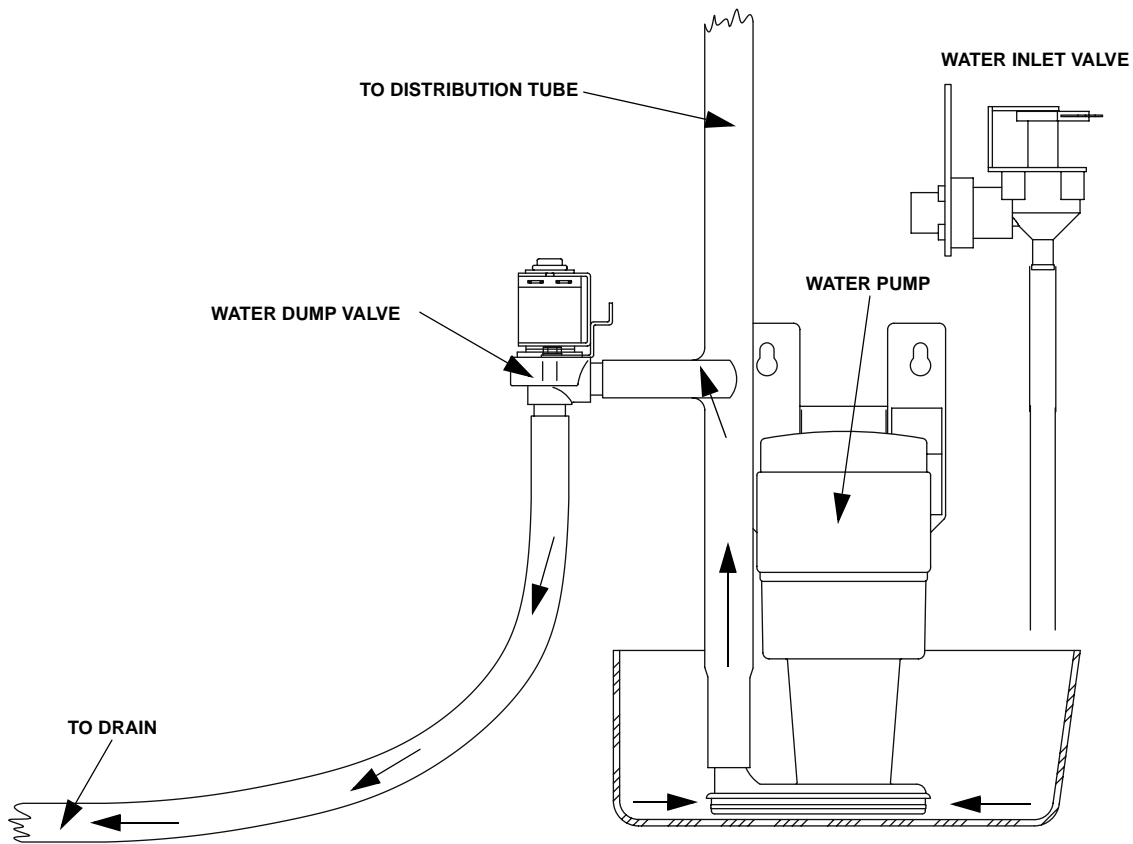

SV1677

**Figure 5-2. Water Flow Down the Drain**

# Section 6 Electrical System

## Energized Parts Charts

### SELF-CONTAINED AIR- AND WATER-COOLED MODELS

| Ice Making Sequence Of Operation                      | Control Board Relays |   |                  |                  |                | Contactor   |                     | Length Of Time                                      |
|---|----------------------|---|------------------|------------------|----------------|-------------|---------------------|---|
|   | 1                    | 2   | 3                | 4                | 5              | 5A          | 5B                  |   |
|   | Water Pump           | Water Fill Valve  | Harvest Valve(s) | Water Dump Valve | Contactor Coil | Com-pressor | Condenser Fan Motor |   |
| <b>START-UP</b> <sup>1</sup><br><b>1. Water Purge</b> | On                   | Off   | On               | On               | Off            | Off         | Off                 | 45 Seconds  |
| <b>2. Refrigeration System Start-Up</b>               | Off                  | On  | On               | Off              | On             | On          | May Cycle On/Off    | 5 Seconds   |
| <b>FREEZE SEQUENCE</b><br><b>3. Pre-Chill</b>         | Off                  | May cycle On/Off during first 45 sec.<br>-----<br>Cycles On, then Off 1 more time<br><br>Locked Out After Six Minutes | Off              | Off              | On             | On          | May Cycle On/Off    | 30 Seconds  |
| <b>4. Freeze</b>                                      | On                   |   | Off              | Off              | On             | On          | May Cycle On/Off    | Until 7 sec. water contact with ice thickness probe |
| <b>HARVEST SEQUENCE</b><br><b>5. Water Purge</b>      | On                   | 30 sec. Off, 15 sec. On   | On               | On               | On             | On          | May Cycle On/Off    | Factory-set at 45 Seconds                           |
| <b>6. Harvest</b>                                     | Off                  | Off   | On               | Off              | On             | On          | May Cycle On/Off    | Bin switch activation                               |
| <b>7. AUTOMATIC SHUT-OFF</b>                          | Off                  | Off   | Off              | Off              | Off            | Off         | Off                 | Until bin switch re-closes                          |

1. Initial Start-Up or Start-Up After Automatic Shut-Off

#### Condenser Fan Motor

The fan motor is wired through a fan cycle pressure control, therefore, it may cycle on and off.

#### Harvest Water Purge

The circuit board has an adjustable water purge in the harvest cycle. This permits a 15, 30 or 45 second purge cycle.

#### Auto Shut-Off

The ice machine remains off for 3 minutes before it can automatically restart. The ice machine restarts (steps 1-2) immediately after the delay period, if the bin switch re-closes prior to 3 minutes.

#### Safety Timers

The control board has the following non-adjustable safety timers:

#### FREEZE SEQUENCE

- The ice machine is locked into the freeze cycle for the first 6 minutes, not allowing the ice thickness probe to initiate a harvest sequence.
- The maximum freeze time is 60 minutes, at which time the control board automatically initiates a harvest sequence (steps 5-6).

#### HARVEST SEQUENCE

The maximum harvest time is 3-1/2 minutes, at which time the control board automatically terminates the harvest sequence. If the bin switch is open, the ice machine will go to automatic shut-off (step 7). If the bin switch is closed, the ice machine will go to the freeze sequence (steps 3-4).

REMOTE MODELS

| Ice Making Sequence Of Operation                      | Control Board Relays |  |                         |                  |                   | Contactor   |                     | Length Of Time                                      |
|---|----------------------|--|-------------------------|------------------|-------------------|-------------|---------------------|---|
|   | 1                    | 2  | 3                       | 4                | 5                 | 5A          | 5B                  |   |
|   | Water Pump           | Water Fill Valve   | a. Harvest Valve(s)     | Water Dump Valve | a. Contactor Coil | Com-pressor | Condenser Fan Motor |   |
| b. HPR Solenoid                                       |                      |  | b. Liquid Line Solenoid |                  |                   |             |                     |   |
| <b>START-UP</b> <sup>1</sup><br><b>1. Water Purge</b> | On                   | Off  | On                      | On               | Off               | Off         | Off                 | 45 Seconds  |
| <b>2. Refrigeration System Start-Up</b>               | Off                  | On   | On                      | Off              | On                | On          | On                  | 5 Seconds   |
| <b>FREEZE SEQUENCE</b><br><b>3. Pre-Chill</b>         | Off                  | May cycle On/Off during first 45 sec.                        | Off                     | Off              | On                | On          | On                  | 30 Seconds  |
| <b>4. Freeze</b>                                      | On                   | Cycles On, then Off 1 more time Locked Out After Six Minutes | Off                     | Off              | On                | On          | On                  | Until 7 sec. water contact with ice thickness probe |
| <b>HARVEST SEQUENCE</b><br><b>5. Water Purge</b>      | On                   | 30 sec. Off, 15 sec. On                                      | On                      | On               | On                | On          | On                  | Factory-set at 45 Seconds                           |
| <b>6. Harvest</b>                                     | Off                  | Off  | On                      | Off              | On                | On          | On                  | Bin switch activation                               |
| <b>7. AUTOMATIC SHUT-OFF</b>                          | Off                  | Off  | Off                     | Off              | Off               | Off         | Off                 | Until bin switch re-closes                          |

1. Initial Start-Up or Start-Up After Automatic Shut-Off

**Auto Shut-Off**

The ice machine remains off for 3 minutes before it can automatically restart. The ice machine restarts (steps 1-2) immediately after the delay period, if the bin switch re-closes prior to 3 minutes.

**Harvest Water Purge**

The circuit board has an adjustable water purge in the harvest cycle. This permits a 15, 30 or 45 second purge cycle.

**Safety Timers**

The control board has the following non-adjustable safety timers:

FREEZE SEQUENCE

- The ice machine is locked into the freeze cycle for the first 6 minutes, not allowing the ice thickness probe to initiate a harvest sequence.
- The maximum freeze time is 60 minutes, at which time the control board automatically initiates a harvest sequence (steps 5-6).

HARVEST SEQUENCE

- The maximum harvest time is 3-1/2 minutes, at which time the control board automatically terminates the harvest sequence. If the bin switch is open, the ice machine will go to automatic shut-off (step 7). If the bin switch is closed, the ice machine will go to the freeze sequence (steps 3-4).

**Wiring Diagram Sequence of Operation**

**SELF-CONTAINED MODELS**

**Initial Start-Up or Start-Up After Automatic Shut-Off**

**1. WATER PURGE**

Before the compressor starts, the water pump and water dump solenoid are energized for 45 seconds to purge old water from the ice machine. This ensures that the ice-making cycle starts with fresh water.

The harvest valve(s) is also energized during the water purge. In the case of an initial refrigeration start-up, it stays on for an additional 5 seconds (50 seconds total).

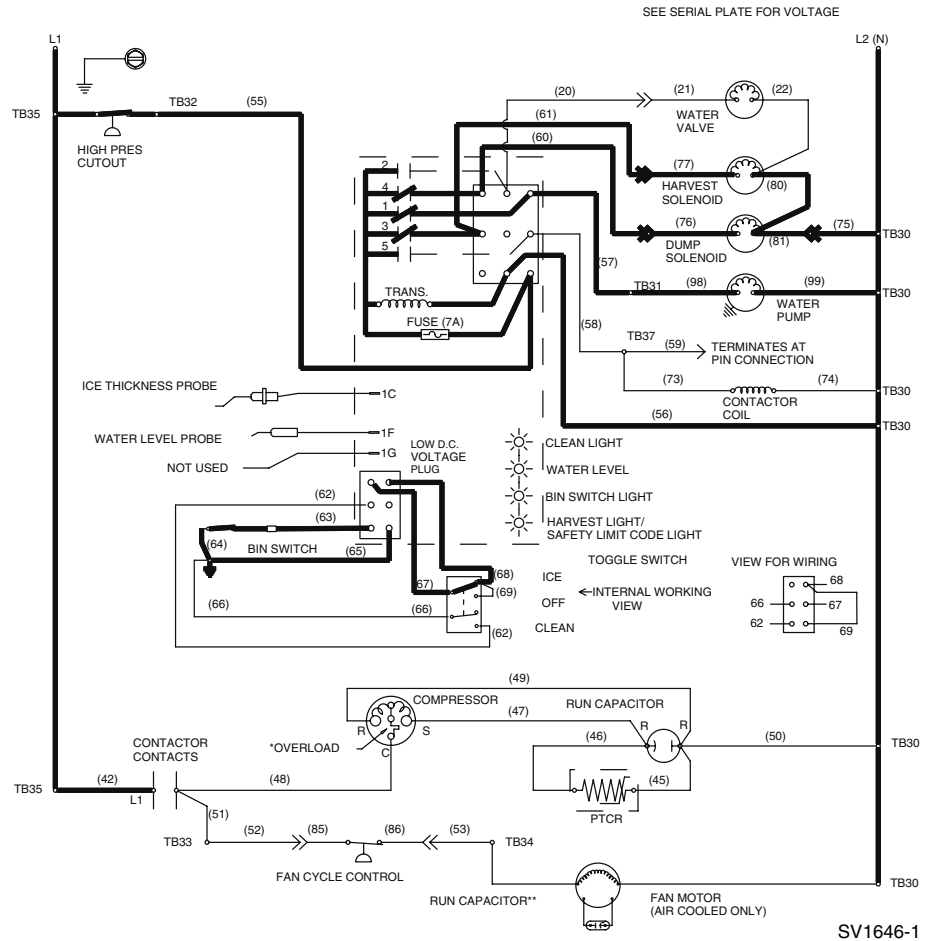

Figure 6-1.

**Self-Contained — Water Purge**

Table 6-1. Self-Contained Models

| 1. Water Purge (45 Seconds)                                     |                              |             |
|---|------------------------------|-------------|
| <b>Toggle Switch</b>  |                              | ICE         |
| <b>Bin Switch</b>   |                              | Closed      |
| <b>Control Board Relays</b>                                     |                              |             |
| #1  | Water Pump                   | Closed / ON |
| #2  | Water Fill Valve             | Open / OFF  |
| #3  | Harvest Solenoid             | Closed / ON |
| #4  | Water Dump Valve             | Closed / ON |
| #5  | Contactor Coil               | Open / OFF  |
|   | Compressor                   | OFF         |
|   | Condenser Fan Motor          | OFF         |
| <b>Safety Controls (Which could stop ice machine operation)</b> |                              |             |
|   | High Pressure Cut-Out        | Closed      |
|   | Main Fuse (On Control Board) | Closed      |

**2. REFRIGERATION SYSTEM START-UP**

The compressor starts after the 45-second water purge, and it remains on throughout the Freeze and Harvest cycles.

The water fill valve is energized at the same time as the compressor. It remains on until the water level sensor closes for 3 continuous seconds.

The harvest valve(s) remains on for the first 5 seconds of the initial compressor start-up.

At the same time the compressor starts, the condenser fan motor (air-cooled models) is supplied with power. It continues to be supplied with power throughout the Freeze and Harvest cycles.

The fan motor is wired through a fan cycle pressure control, and may cycle on and off. (The compressor and the condenser fan motor are wired through the contactor. Any time the contactor coil is energized, these components are supplied with power.)

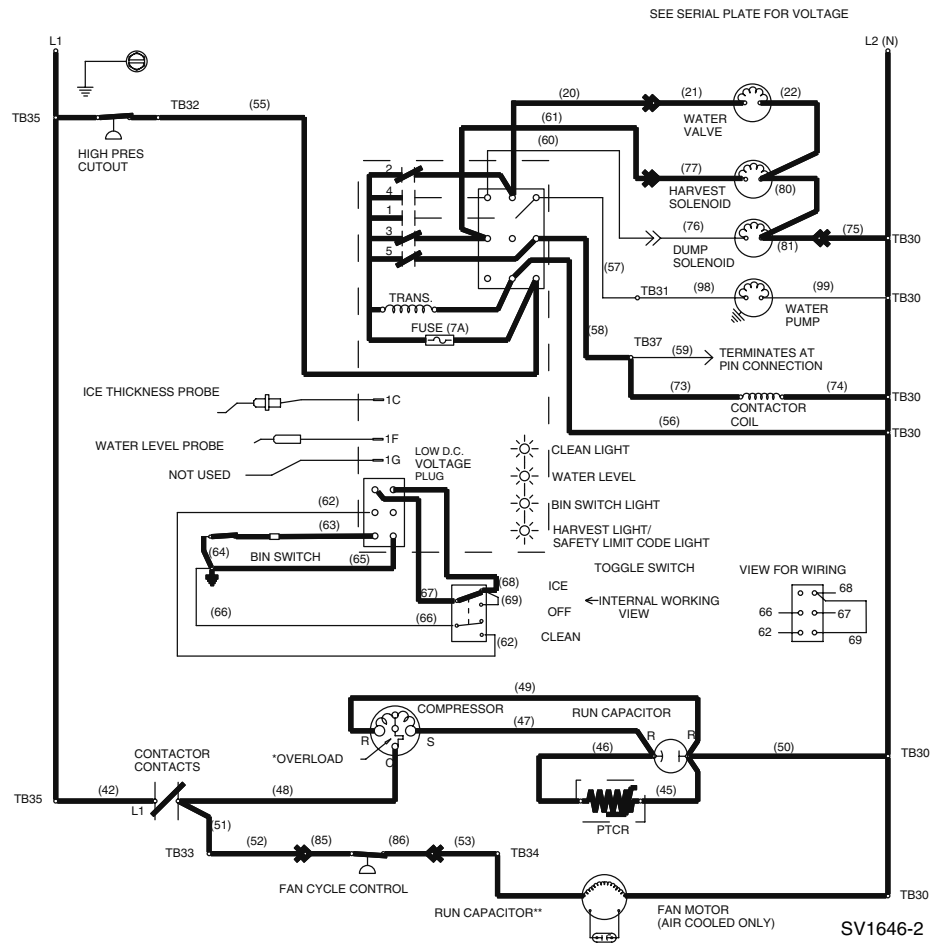

**Figure 6-2. Self-Contained — Refrigeration System Start-Up**

**Table 6-2. Self-Contained Models**

| 2. Refrigeration System Start Up (5 Seconds)                    |                              |             |
|---|------------------------------|-------------|
| <b>Toggle Switch</b>  |                              | ICE         |
| <b>Bin Switch</b>   |                              | Closed      |
| <b>Control Board Relays</b>                                     |                              |             |
| #1  | Water Pump                   | Open / OFF  |
| #2  | Water Fill Valve             | Closed / ON |
| #3  | Harvest Solenoid             | Closed / ON |
| #4  | Water Dump Valve             | Open / OFF  |
| #5  | Contactor Coil               | Closed / ON |
|   | Compressor                   | ON          |
|   | Condenser Fan Motor          | ON          |
| <b>Safety Controls (Which could stop ice machine operation)</b> |                              |             |
|   | High Pressure Cut-Out        | Closed      |
|   | Main Fuse (On Control Board) | Closed      |



Freeze Sequence

3. PRE-CHILL

To pre-charge the evaporator, the compressor runs for 30 seconds prior to water flow.

The water fill valve remains on until the water level sensor closes for three continuous seconds.

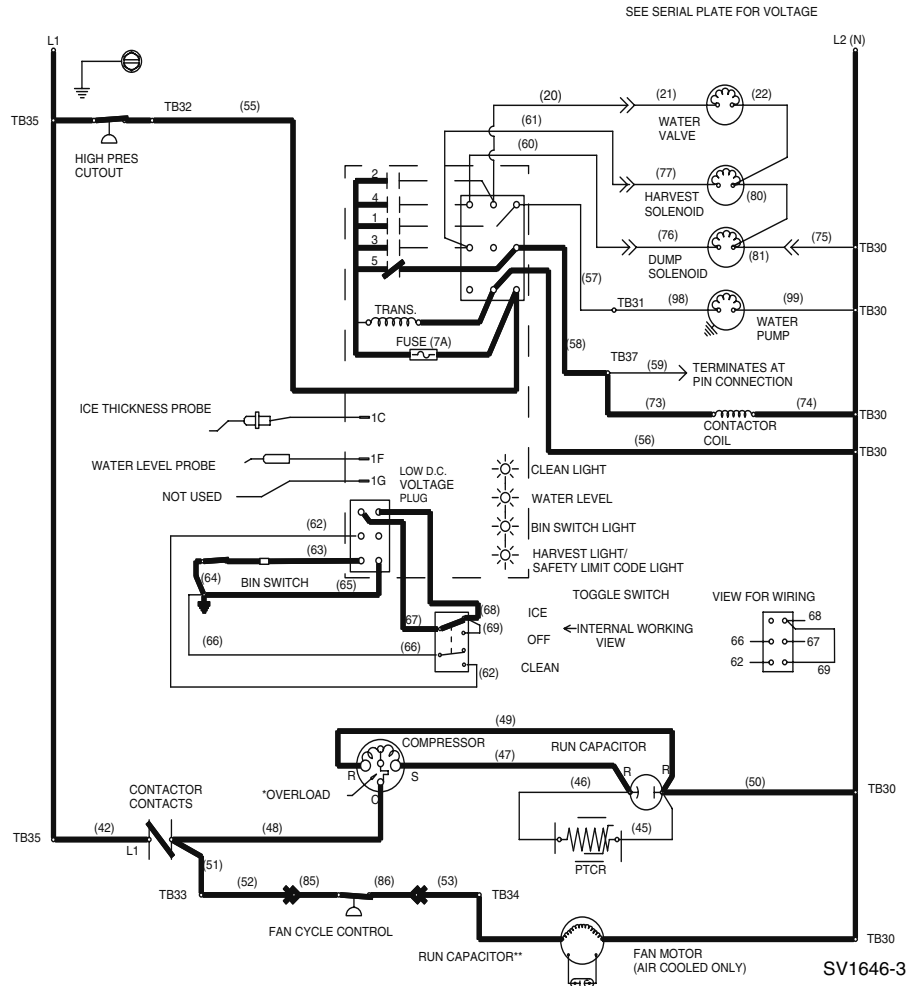

Figure 6-3. Self-Contained — Pre-Chill

Table 6-3. Self-Contained Models

| 3. Pre-Chill (30 Seconds)                                       |                              |             |
|---|------------------------------|-------------|
| <b>Toggle Switch</b>  |                              | ICE         |
| <b>Bin Switch</b>   |                              | Closed      |
| <b>Control Board Relays</b>                                     |                              |             |
| #1  | Water Pump                   | Open / OFF  |
| #2  | Water Fill Valve             | Closed / ON |
| #3  | Harvest Solenoid             | Open / OFF  |
| #4  | Water Dump Valve             | Open / OFF  |
| #5  | Contactor Coil               | Closed / ON |
|   | Compressor                   | ON          |
|   | Condenser Fan Motor          | ON          |
| <b>Safety Controls (Which could stop ice machine operation)</b> |                              |             |
|   | High Pressure Cut-Out        | Closed      |
|   | Main Fuse (On Control Board) | Closed      |

4. FREEZE

The water pump starts after the 30-second pre-chill. An even flow of water is directed across the evaporator and into each cube cell, where it freezes.

After six minutes the water inlet valve is locked out and can not add additional water.

When sufficient ice has formed, the water flow (not the ice) contacts the ice thickness probes. After approximately 7 seconds of continual contact, a harvest cycle is initiated.

NOTE: The ice machine cannot initiate a harvest cycle until a 6-minute freeze lock has expired.

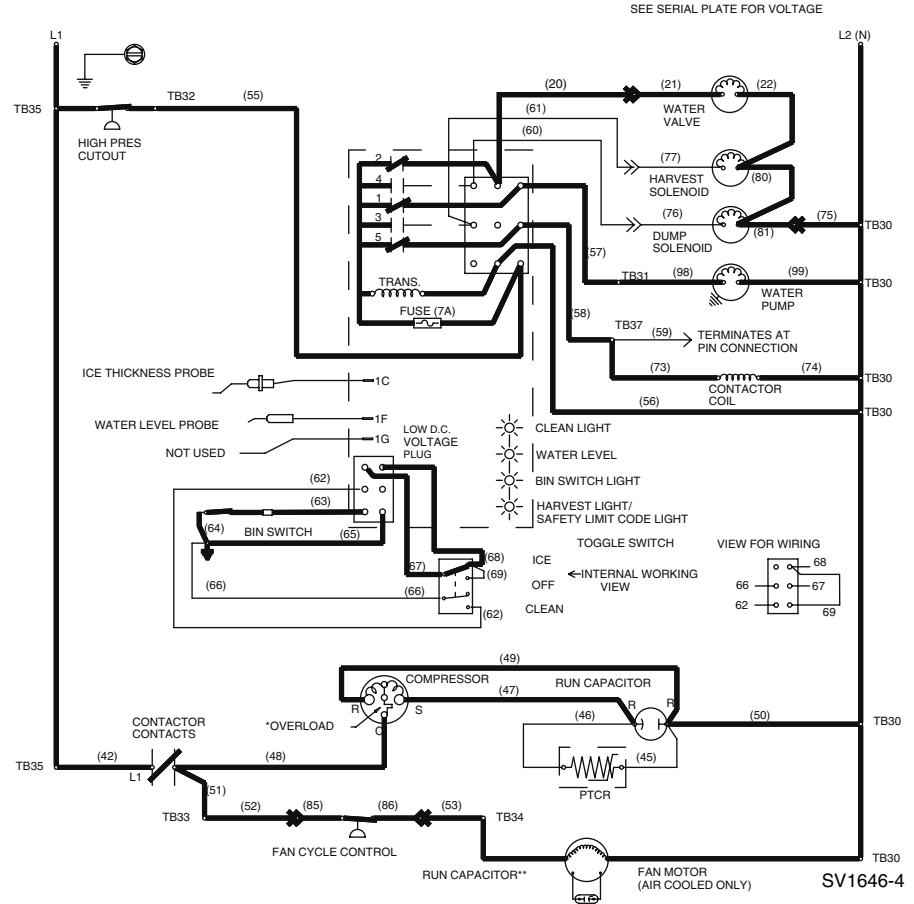

Figure 6-4. Self-Contained — Freeze

Table 6-4. Self-Contained Models

| 4. Freeze (Until 7 Seconds of Water Contact with Ice Thickness Probe) |                              |                    |
|---|------------------------------|--------------------|
| <b>Toggle Switch</b>  |                              | ICE                |
| <b>Bin Switch</b>   |                              | Closed             |
| <b>Control Board Relays</b>   |                              |                    |
| #1  | Water Pump                   | Closed / ON        |
| #2  | Water Fill Valve             | Cycles ON then OFF |
| #3  | Harvest Solenoid             | Open / OFF         |
| #4  | Water Dump Valve             | Open / OFF         |
| #5  | Contactur Coil               | Closed / ON        |
|   | Compressor                   | ON                 |
|   | Condenser Fan Motor          | ON                 |
| <b>Safety Controls (Which could stop ice machine operation)</b>       |                              |                    |
|   | High Pressure Cut-Out        | Closed             |
|   | Main Fuse (On Control Board) | Closed             |

**Harvest Sequence**

**5. WATER PURGE**

The water pump continues to run, and the water dump valve energizes for 45 seconds to purge the water in the sump trough. The water fill valve energizes (turns on) and de-energizes (turns off) strictly by time. The water fill valve energizes for the last 15 seconds of the 45-second water purge. The water purge must be at the factory setting of 45 seconds for the fill valve to energize during the last 15 seconds of the Water Purge. If set at less than 45 seconds, the water fill valve does not energize during the water purge.

After the 45 second water purge, the water fill valve, water pump and dump valve de-energize. (Refer to “Water Purge Adjustment” on **Page 3-3** for details.) The harvest valve also opens at the beginning of the water purge to divert hot refrigerant gas into the evaporator.

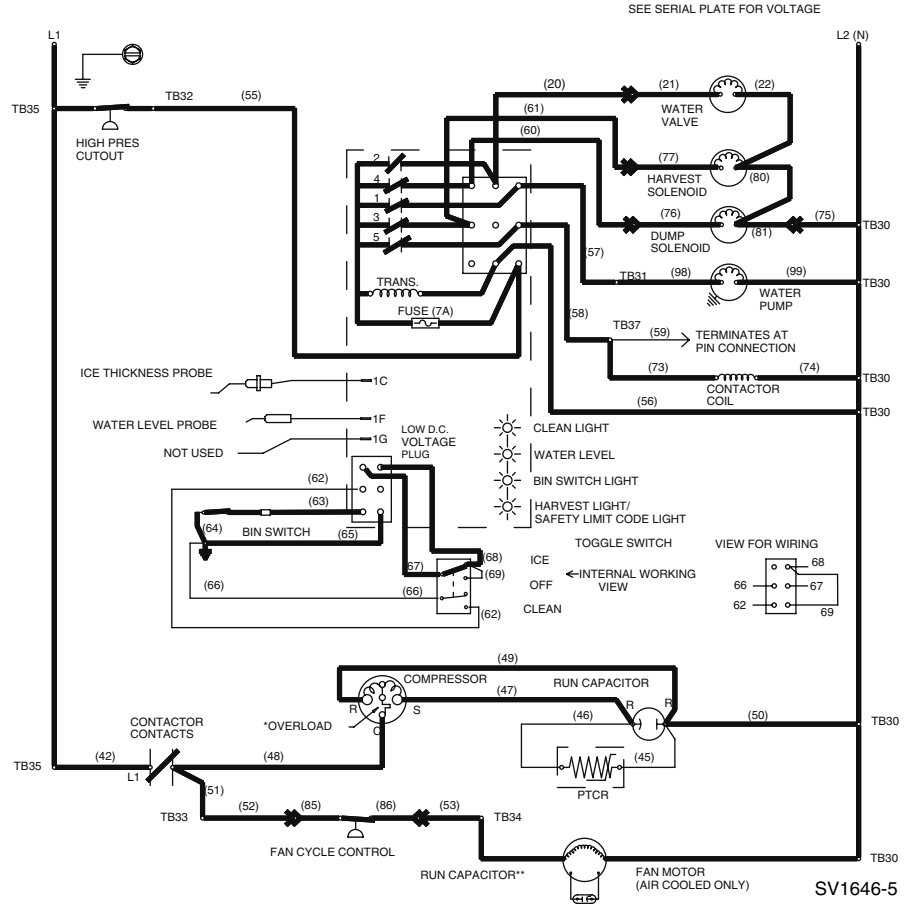

Figure 6-5.

**Self-Contained — Water Purge**

Table 6-5. Self-Contained Models

| 5. Water Purge (45 Seconds)                                     |                              |                    |
|---|------------------------------|--------------------|
| <b>Toggle Switch</b>  |                              | ICE                |
| <b>Bin Switch</b>   |                              | Closed             |
| <b>Control Board Relays</b>                                     |                              |                    |
| #1  | Water Pump                   | Closed / ON        |
| #2  | Water Fill Valve             | Cycles OFF then ON |
| #3  | Harvest Solenoid             | Closed / ON        |
| #4  | Water Dump Valve             | Closed / ON        |
| #5  | Contactor Coil               | Closed / ON        |
|   | Compressor                   | ON                 |
|   | Condenser Fan Motor          | ON                 |
| <b>Safety Controls (Which could stop ice machine operation)</b> |                              |                    |
|   | High Pressure Cut-Out        | Closed             |
|   | Main Fuse (On Control Board) | Closed             |

6. HARVEST

The harvest valve(s) remains open, allowing refrigerant gas to warm the evaporator. This causes the cubes to slide, as a sheet, off the evaporator and into the storage bin.

The sliding sheet of cubes swings the water curtain out, opening the bin switch. This momentary opening and closing of the bin switch terminates the Harvest Cycle and returns the ice machine to the Freeze Cycle (steps 3-4).

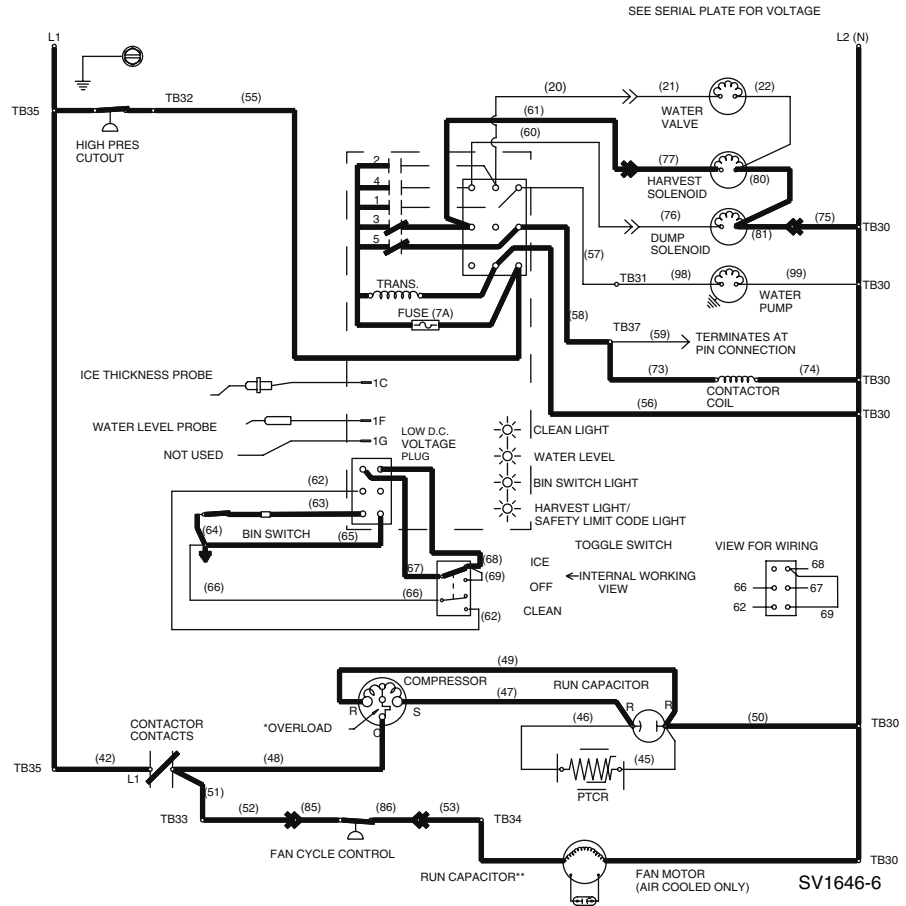

Figure 6-6. Self-Contained — Harvest

Table 6-6. Self-Contained Models

| 6. Harvest (Until Bin Switch Activation)                        |                              |             |
|---|------------------------------|-------------|
| <b>Toggle Switch</b>  |                              | ICE         |
| <b>Bin Switch</b>   |                              | Closed      |
| <b>Control Board Relays</b>                                     |                              |             |
| #1  | Water Pump                   | Open / OFF  |
| #2  | Water Fill Valve             | Open / OFF  |
| #3  | Harvest Solenoid             | Closed / ON |
| #4  | Water Dump Valve             | Open / OFF  |
| #5  | Contacteur Coil              | Closed / ON |
|   | Compressor                   | ON          |
|   | Condenser Fan Motor          | ON          |
| <b>Safety Controls (Which could stop ice machine operation)</b> |                              |             |
|   | High Pressure Cut-Out        | Closed      |
|   | Main Fuse (On Control Board) | Closed      |

**Automatic Shut-Off**

**7. AUTOMATIC SHUT-OFF**

If the storage bin is full at the end of a harvest cycle, the sheet of cubes fails to clear the water curtain and holds it open. After the water curtain is held open for 7 seconds, the ice machine shuts off.

The ice machine remains off until enough ice is removed from the storage bin to allow the sheet of cubes to drop clear of the water curtain. As the water curtain swings back to the operating position, the bin switch closes and the ice machine restarts (steps 1-2).

NOTE: The ice machine must remain off for 3 minutes before it can automatically restart.

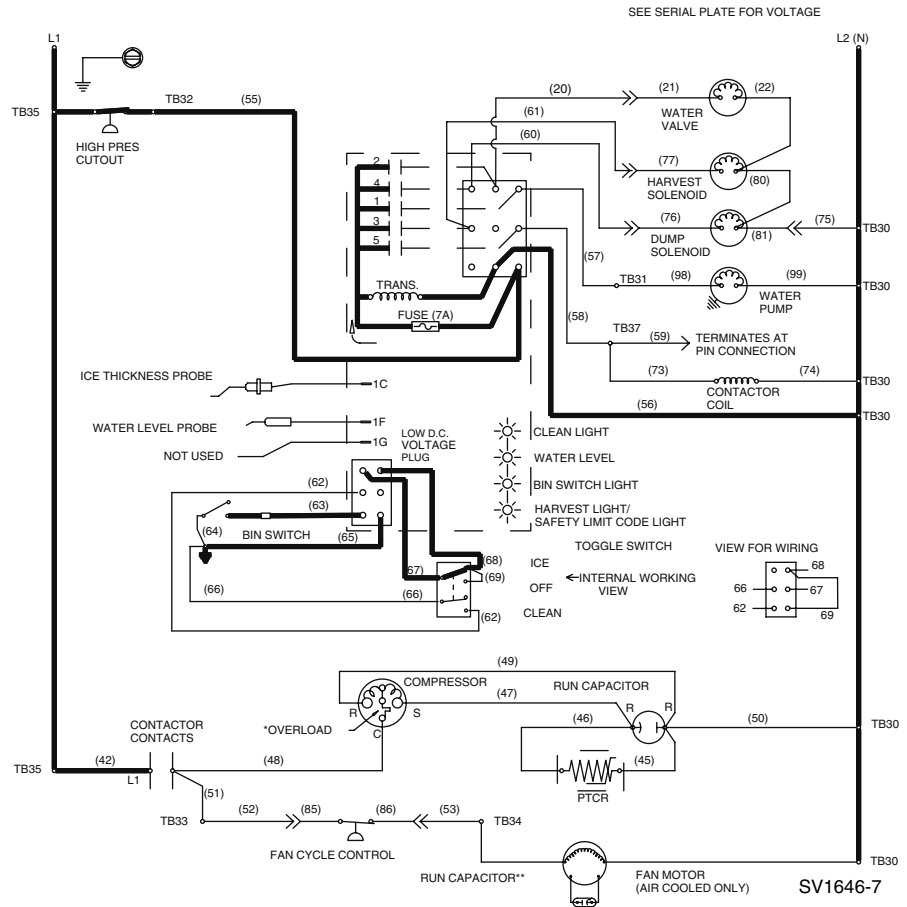

**Figure 6-7. Self-Contained — Automatic Shut-Off**

**Table 6-7. Self-Contained Models**

| 7. Automatic Shut-Off (Until Bin Switch Closes)                 |                              |            |
|---|------------------------------|------------|
| <b>Toggle Switch</b>  |                              | ICE        |
| <b>Bin Switch</b>   |                              | Open       |
| <b>Control Board Relays</b>                                     |                              |            |
| #1  | Water Pump                   | Open / OFF |
| #2  | Water Fill Valve             | Open / OFF |
| #3  | Harvest Solenoid             | Open / OFF |
| #4  | Water Dump Valve             | Open / OFF |
| #5  | Contacting Coil              | Open / OFF |
|   | Compressor                   | OFF        |
|   | Condenser Fan Motor          | OFF        |
| <b>Safety Controls (Which could stop ice machine operation)</b> |                              |            |
|   | High Pressure Cut-Out        | Closed     |
|   | Main Fuse (On Control Board) | Closed     |

REMOTE MODELS

Initial Start-Up Or Start-Up After Automatic Shut-Off

1. WATER PURGE

Before the compressor starts, the water pump and water dump solenoid are energized for 45 seconds to purge old water from the ice machine. This ensures that the ice-making cycle starts with fresh water.

NOTE: The harvest valve and harvest pressure regulating (HPR) solenoid valve are also energized during the water purge. In the case of an initial refrigeration start-up, they stay on for an additional 5 seconds (50 seconds total).

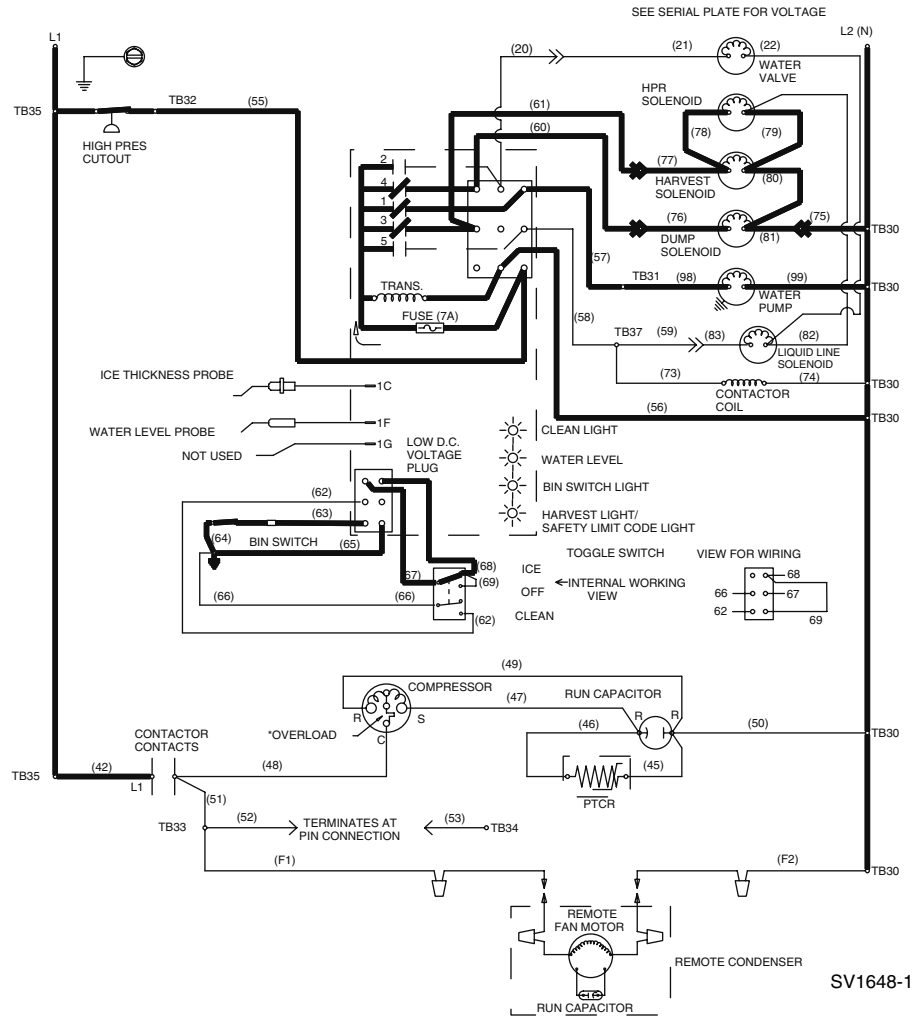

Figure 6-8. Remote — Water Purge

Table 6-8. Remote Models

| 1. Water Purge (45 Seconds)                                     |  |              |
|---|--|--------------|
| <b>Toggle Switch</b>  |  | ICE          |
| <b>Bin Switch</b>   |  | Closed       |
| <b>Control Board Relays</b>                                     |  |              |
| #1  | Water Pump                                 | Closed / ON  |
| #2  | Water Fill Valve                           | Open / OFF   |
| #3  | Harvest Solenoid                           | Closed / ON  |
|   | Harvest Pressure Regulating (HPR) Solenoid | Closed / ON  |
| #4  | Water Dump Valve                           | Closed / ON  |
| #5  | Contactor Coil                             | Open / OFF   |
|   | Liquid Line Solenoid                       | De-energized |
|   | Compressor                                 | OFF          |
|   | Condenser Fan Motor                        | OFF          |
| <b>Safety Controls (Which could stop ice machine operation)</b> |  |              |
|   | High Pressure Cut-Out                      | Closed       |
|   | Main Fuse (On Control Board)               | Closed       |

2. REFRIGERATION SYSTEM

START-UP

The compressor, remote condenser fan motor and liquid line solenoid energize after the 45-second water purge, and remain on throughout the Freeze and Harvest cycles.

The water fill valve is energized at the same time as the compressor. It remains on until the water level sensor closes for 3 continuous seconds.

The harvest valve and harvest pressure regulating (HPR) solenoid valve remain on for the first 5 seconds of the initial compressor start-up.

NOTE: (The compressor and the condenser fan motor are wired through the contactor. Any time the contactor coil is energized, these components are supplied with power.)

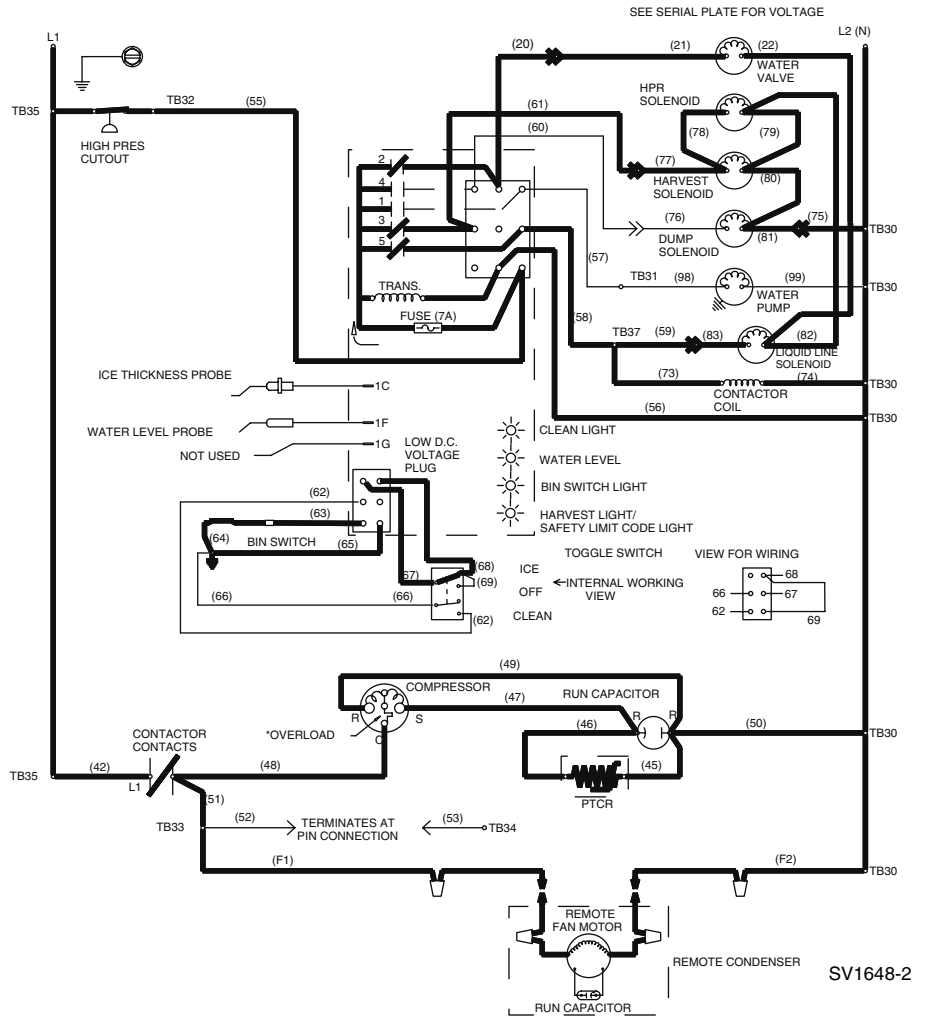

Figure 6-9. Remote — Refrigeration System Start-Up

Table 6-9. Remote Models

| 2. Refrigeration System Start-Up (5 Seconds)                    |  |             |
|---|--|-------------|
| <b>Toggle Switch</b>  |  | ICE         |
| <b>Bin Switch</b>   |  | Closed      |
| <b>Control Board Relays</b>                                     |  |             |
| #1  | Water Pump                                 | Open / OFF  |
| #2  | Water Fill Valve                           | Closed / ON |
| #3  | Harvest Solenoid                           | Closed / ON |
|   | Harvest Pressure Regulating (HPR) Solenoid | Closed / ON |
| #4  | Water Dump Valve                           | Open / OFF  |
| #5  | Contactor Coil                             | Closed / ON |
|   | Liquid Line Solenoid                       | Energized   |
|   | Compressor                                 | ON          |
|   | Condenser Fan Motor                        | ON          |
| <b>Safety Controls (Which could stop ice machine operation)</b> |  |             |
|   | High Pressure Cut-Out                      | Closed      |
|   | Main Fuse (On Control Board)               | Closed      |

Freeze Sequence

3. PRE-CHILL

To pre-chill the evaporator, the compressor runs for 30 seconds prior to water flow.

NOTE: The water fill valve remains on until the water level sensor closes for three continuous seconds.

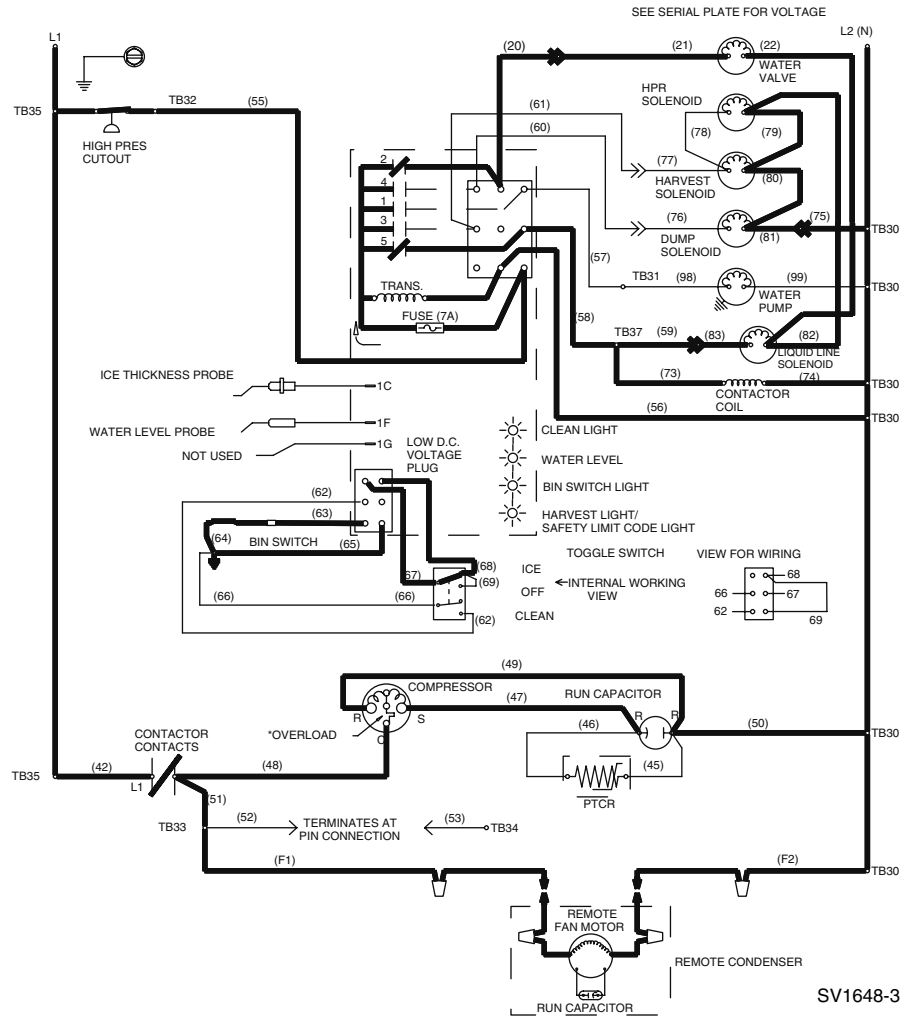

Figure 6-10. Remote — Pre-Chill

Table 6-10. Remote Models

| 3. Pre-Chill (30 Seconds)                                       |  |             |
|---|--|-------------|
| <b>Toggle Switch</b>  |  | ICE         |
| <b>Bin Switch</b>   |  | Closed      |
| <b>Control Board Relays</b>                                     |  |             |
| #1  | Water Pump                                 | Open / OFF  |
| #2  | Water Fill Valve                           | Closed / ON |
| #3  | Harvest Solenoid                           | Open / OFF  |
|   | Harvest Pressure Regulating (HPR) Solenoid | Open / OFF  |
| #4  | Water Dump Valve                           | Open / OFF  |
| #5  | Contactors                                 | Closed / ON |
|   | Liquid Line Solenoid                       | Energized   |
|   | Compressor                                 | ON          |
|   | Condenser Fan Motor                        | ON          |
| <b>Safety Controls (Which could stop ice machine operation)</b> |  |             |
|   | High Pressure Cut-Out                      | Closed      |
|   | Main Fuse (On Control Board)               | Closed      |



4. FREEZE

The water pump starts after the 30-second pre-chill. An even flow of water is directed across the evaporator and into each cube cell, where it freezes.

After six minutes the water inlet valve is locked out and can not add additional water.

When sufficient ice has formed, the water flow (not the ice) contacts the ice thickness probes. After approximately 7 seconds of continual contact, a harvest cycle is initiated.

NOTE: The ice machine cannot initiate a harvest cycle until a 6-minute freeze lock has expired.

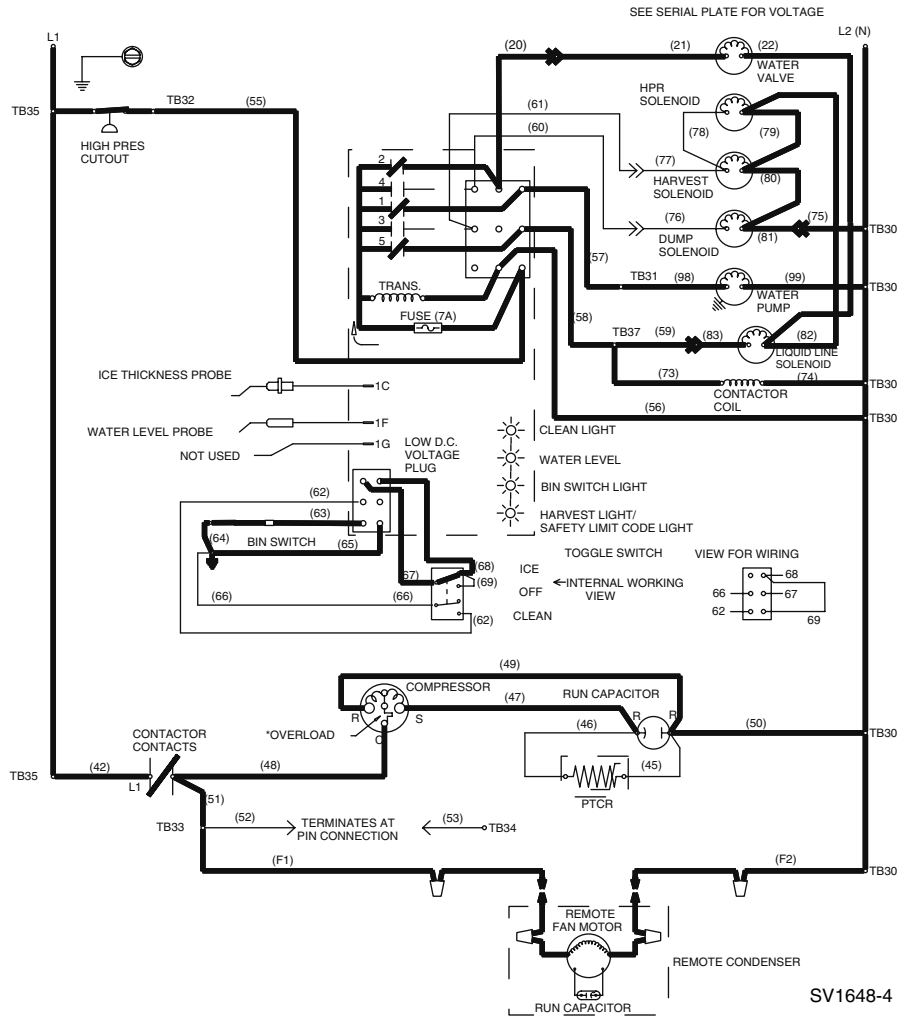

Figure 6-11. Remote — Freeze

Table 6-11. Remote Models

| 4. Freeze (Until 7 Seconds of Water Contact with Ice Thickness Probe) |  |                      |
|---|--|----------------------|
| <b>Toggle Switch</b>  |  | ICE                  |
| <b>Bin Switch</b>   |  | Closed               |
| <b>Control Board Relays</b>   |  |                      |
| #1  | Water Pump                                 | Closed / ON          |
| #2  | Water Fill Valve                           | Cycles / ON then OFF |
| #3  | Harvest Solenoid                           | Open / OFF           |
|   | Harvest Pressure Regulating (HPR) Solenoid | Open / OFF           |
| #4  | Water Dump Valve                           | Open / OFF           |
| #5  | Contactor Coil                             | Closed / ON          |
|   | Liquid Line Solenoid                       | Energized            |
|   | Compressor                                 | ON                   |
|   | Condenser Fan Motor                        | ON                   |
| <b>Safety Controls (Which could stop ice machine operation)</b>       |  |                      |
|   | High Pressure Cut-Out                      | Closed               |
|   | Main Fuse (On Control Board)               | Closed               |

Harvest Sequence

5. WATER PURGE

The water pump continues to run, and the water dump valve energizes for 45 seconds to purge the water in the sump trough. The water fill valve energizes (turns on) and de-energizes (turns off) strictly by time. The water fill valve energizes for the last 15 seconds of the 45-second water purge. The water purge must be at the factory setting of 45 seconds for the fill valve to energize during the last 15 seconds of the Water Purge. If set at less than 45 seconds the water fill valve does not energize during the water purge.

NOTE: After the 45 second water purge, the water fill valve, water pump and dump valve de-energize. (Refer to “Water Purge Adjustment” on **Page 3-3** for details.) The harvest valve and HPR solenoid also open at the beginning of the water purge to divert hot refrigerant gas into the evaporator.

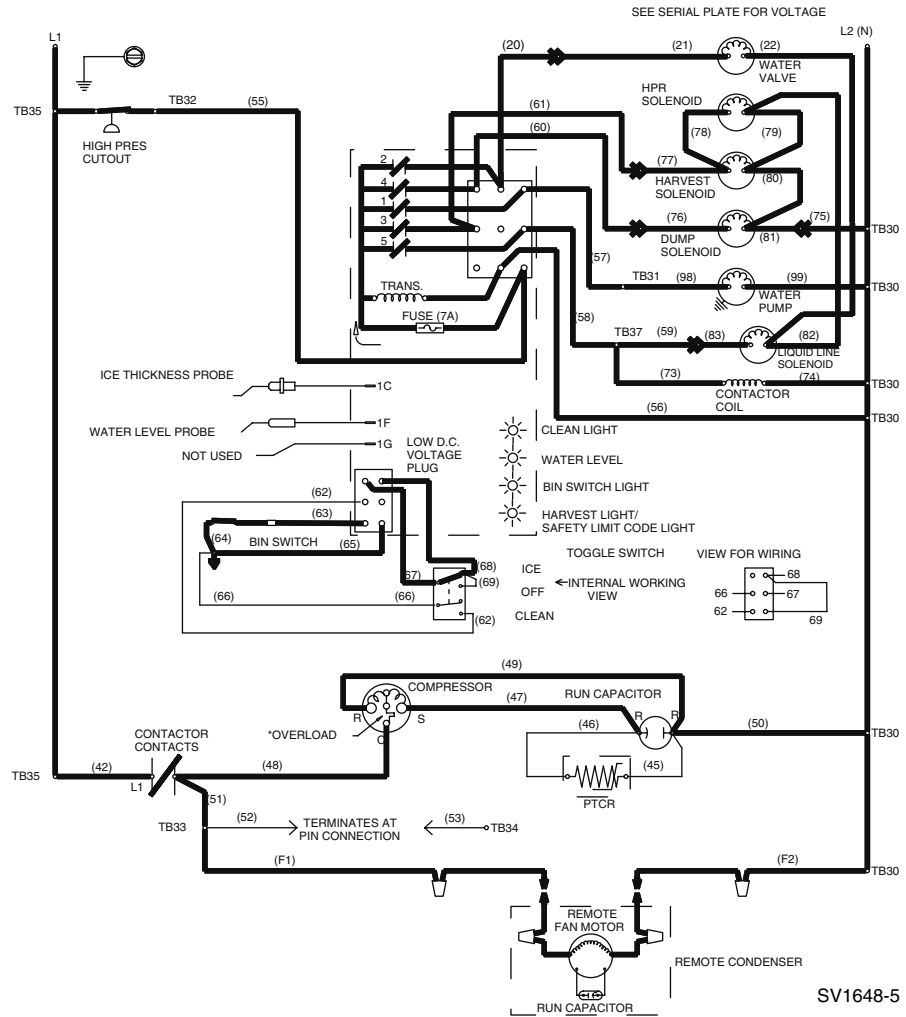

Figure 6-12. Remote — Water Purge

Table 6-12. Remote Models

| 5. Water Purge (45 Seconds)                                     |  |                      |
|---|--|----------------------|
| <b>Toggle Switch</b>  |  | ICE                  |
| <b>Bin Switch</b>   |  | Closed               |
| <b>Control Board Relays</b>                                     |  |                      |
| #1  | Water Pump                                 | Closed / ON          |
| #2  | Water Fill Valve                           | Cycles / OFF then ON |
| #3  | Harvest Solenoid                           | Closed / ON          |
|   | Harvest Pressure Regulating (HPR) Solenoid | Closed / ON          |
| #4  | Water Dump Valve                           | Closed / ON          |
| #5  | Contactor Coil                             | Closed / ON          |
|   | Liquid Line Solenoid                       | Energized            |
|   | Compressor                                 | ON                   |
|   | Condenser Fan Motor                        | ON                   |
| <b>Safety Controls (Which could stop ice machine operation)</b> |  |                      |
|   | High Pressure Cut-Out                      | Closed               |
|   | Main Fuse (On Control Board)               | Closed               |

6. HARVEST

The harvest valve(s) and HPR solenoid valve remain open, allowing refrigerant gas to warm the evaporator. This causes the cubes to slide, as a sheet, off the evaporator and into the storage bin.

The sliding sheet of cubes swings the water curtain out, opening the bin switch. This momentary opening and closing of the bin switch terminates the Harvest Cycle and returns the ice machine to the Freeze Cycle (steps 3-4).

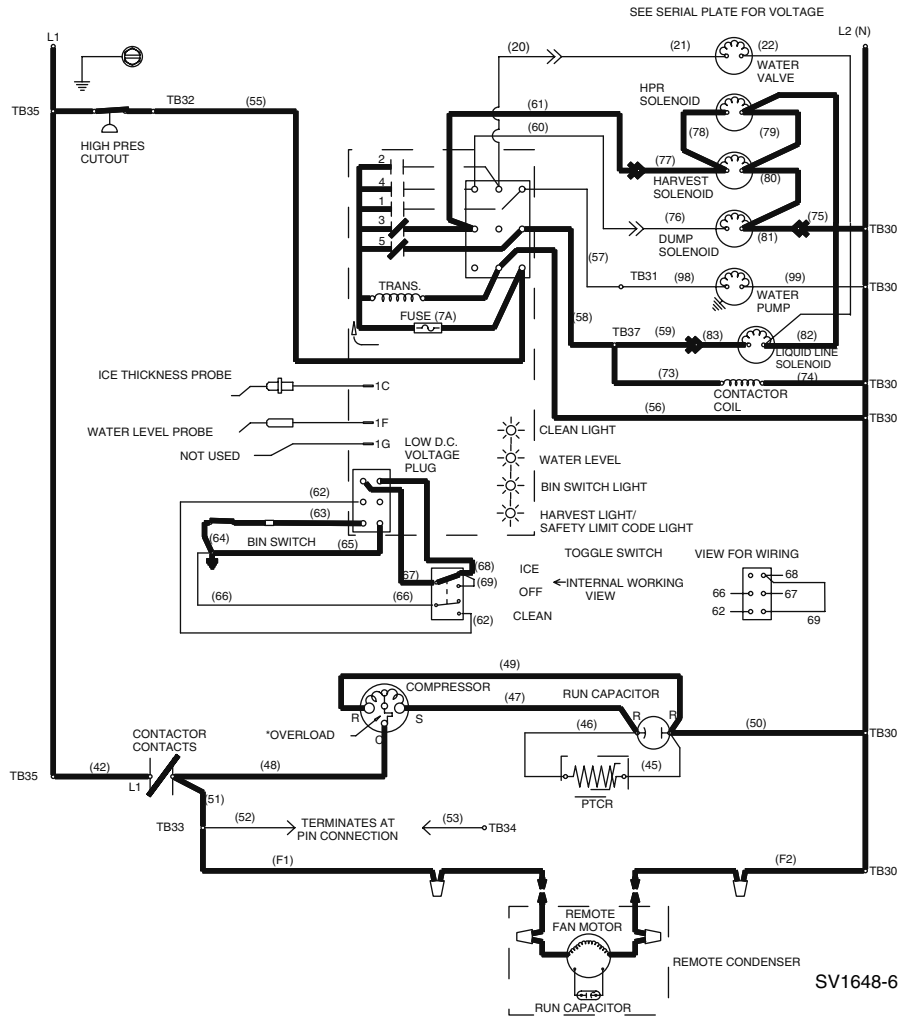

Figure 6-13. Remote — Harvest

Table 6-13. Remote Models

| 6. Harvest (Until Bin Switch Activation)                        |  |             |
|---|--|-------------|
| <b>Toggle Switch</b>  |  | ICE         |
| <b>Bin Switch</b>   |  | Closed      |
| <b>Control Board Relays</b>                                     |  |             |
| #1  | Water Pump                                 | Open / OFF  |
| #2  | Water Fill Valve                           | Open / OFF  |
| #3  | Harvest Solenoid                           | Closed / ON |
|   | Harvest Pressure Regulating (HPR) Solenoid | Closed / ON |
| #4  | Water Dump Valve                           | Open / OFF  |
| #5  | Contactor Coil                             | Closed / ON |
|   | Liquid Line Solenoid                       | Energized   |
|   | Compressor                                 | ON          |
|   | Condenser Fan Motor                        | ON          |
| <b>Safety Controls (Which could stop ice machine operation)</b> |  |             |
|   | High Pressure Cut-Out                      | Closed      |
|   | Main Fuse (On Control Board)               | Closed      |

**Automatic Shut-Off**

**7. AUTOMATIC SHUT-OFF**

If the storage bin is full at the end of a harvest cycle, the sheet of cubes fails to clear the water curtain and holds it open. After the water curtain is held open for 7 seconds, the ice machine shuts off.

The ice machine remains off until enough ice is removed from the storage bin to allow the sheet of cubes to drop clear of the water curtain. As the water curtain swings back to the operating position, the bin switch closes and the ice machine restarts.

**NOTE:** The ice machine must remain off for 3 minutes before it can automatically restart.

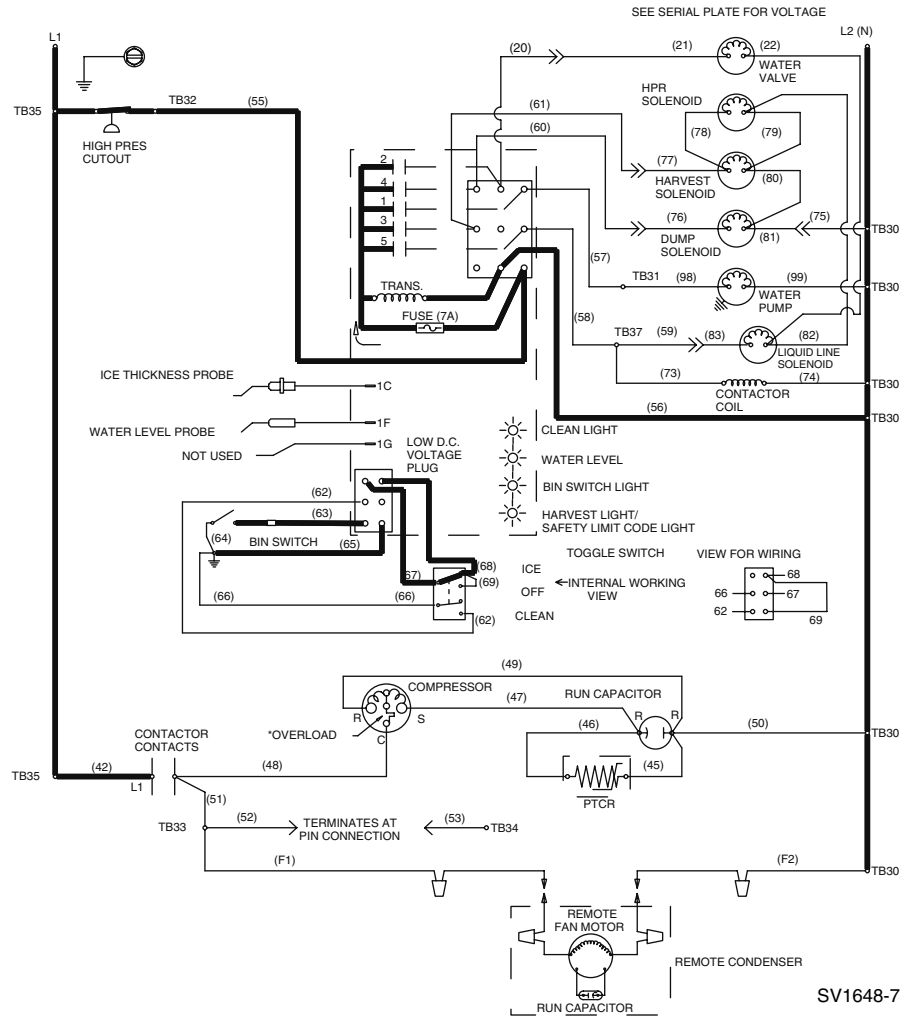

**Figure 6-14. Remote — Automatic Shut-Off**

**Table 6-14. Remote Models**

| 7. Automatic Shut-Off (Until Bin Switch Closes)                 |  |              |
|---|--|--------------|
| <b>Toggle Switch</b>  |  | ICE          |
| <b>Bin Switch</b>   |  | Open         |
| <b>Control Board Relays</b>                                     |  |              |
| #1  | Water Pump                                 | Open / OFF   |
| #2  | Water Fill Valve                           | Open / OFF   |
| #3  | Harvest Solenoid                           | Open / OFF   |
|   | Harvest Pressure Regulating (HPR) Solenoid | Open / OFF   |
| #4  | Water Dump Valve                           | Open / OFF   |
| #5  | Contactor Coil                             | Open / OFF   |
|   | Liquid Line Solenoid                       | De-energized |
|   | Compressor                                 | ON           |
|   | Condenser Fan Motor                        | ON           |
| <b>Safety Controls (Which could stop ice machine operation)</b> |  |              |
|   | High Pressure Cut-Out                      | Closed       |
|   | Main Fuse (On Control Board)               | Closed       |

## Wiring Diagrams

The following pages contain electrical wiring diagrams. Be sure you are referring to the correct diagram for the ice machine which you are servicing.

 **Warning**

Always disconnect power before working on electrical circuitry.

### WIRING DIAGRAM LEGEND

The following symbols are used on all of the wiring diagrams:

- \* Internal Compressor Overload  
(Some models have external compressor overloads)
- \*\* Fan Motor Run Capacitor  
(Some models do not incorporate fan motor run capacitor)
- TB** Terminal Board Connection  
(Terminal board numbers are printed on the actual terminal board)
- ( )** Wire Number Designation  
(The number is marked at each end of the wire)
- >>— Multi-Pin Connection  
(Electrical Box Side) —>>— (Compressor Compartment Side)

Q200/Q280/Q320 - SELF CONTAINED - 1 PHASE WITH TERMINAL BOARD

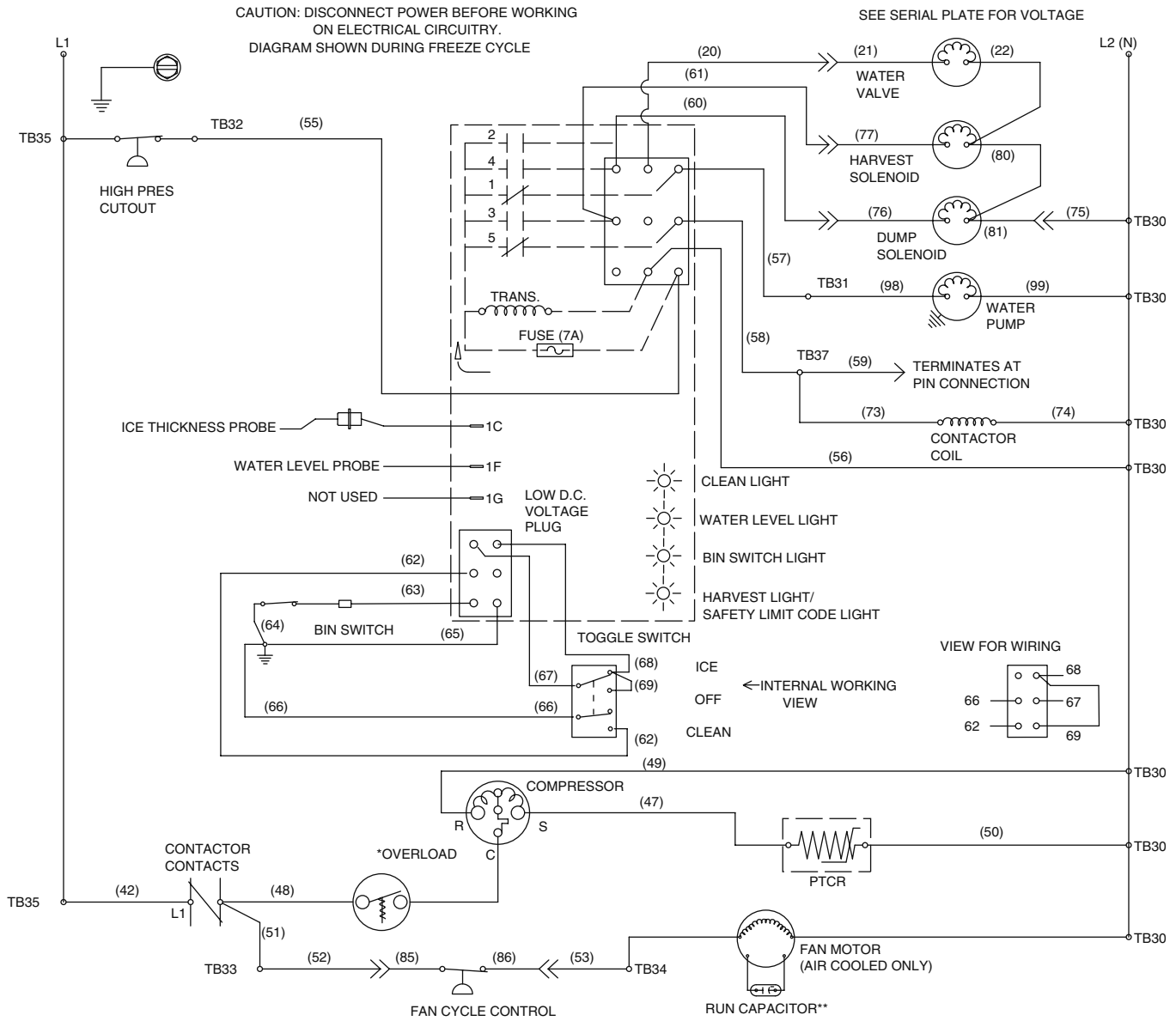

SV1654

Q280/Q370 - SELF CONTAINED - 1 PHASE WITHOUT TERMINAL BOARD

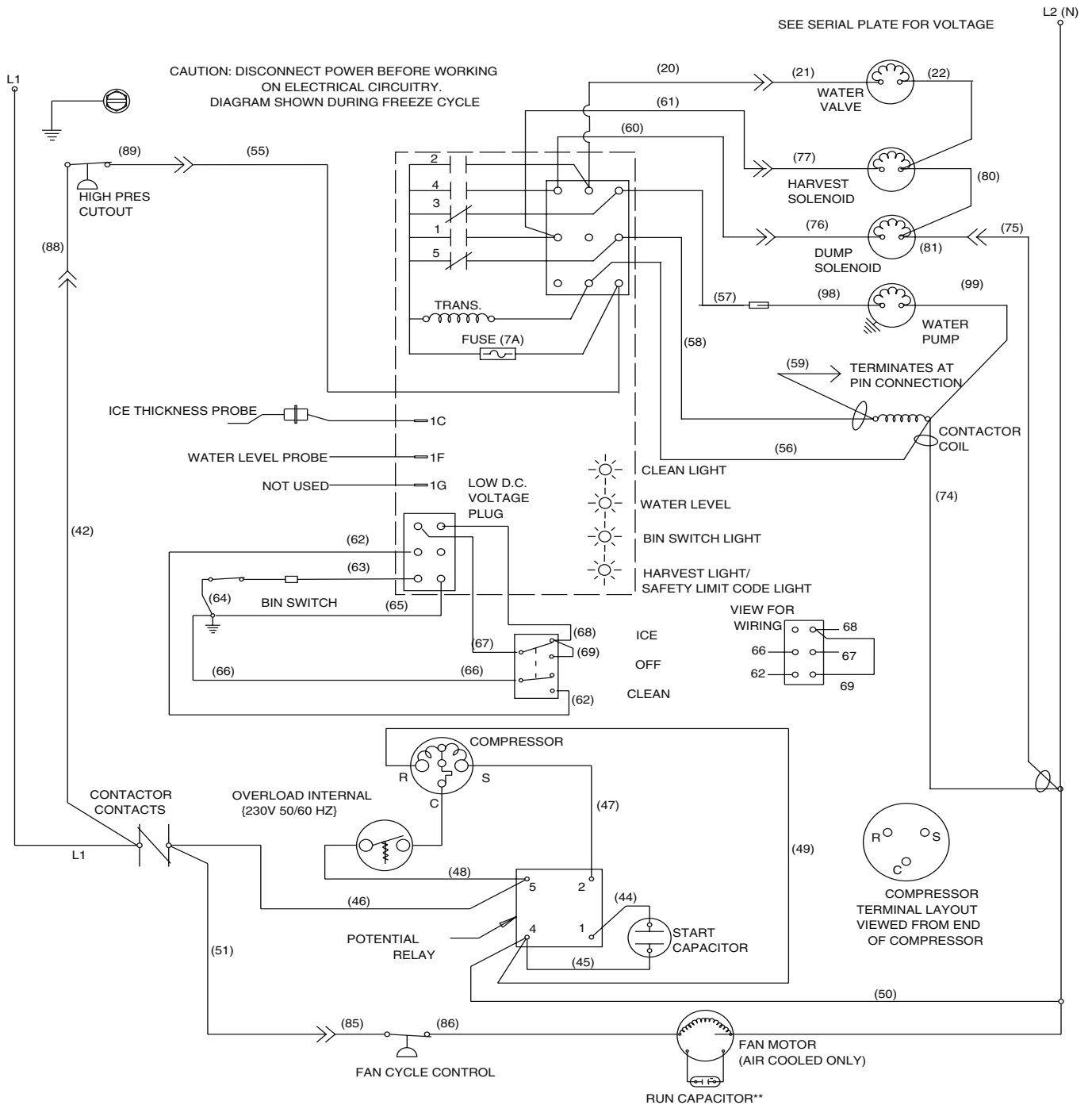

SV3018

Q320 - SELF CONTAINED - 1 PHASE WITHOUT TERMINAL BOARD

CAUTION: DISCONNECT POWER BEFORE WORKING ON ELECTRICAL CIRCUITRY.  
ON ELECTRICAL CIRCUITRY.

SEE SERIAL PLATE FOR VOLTAGE

DIAGRAM SHOWN DURING FREEZE CYCLE

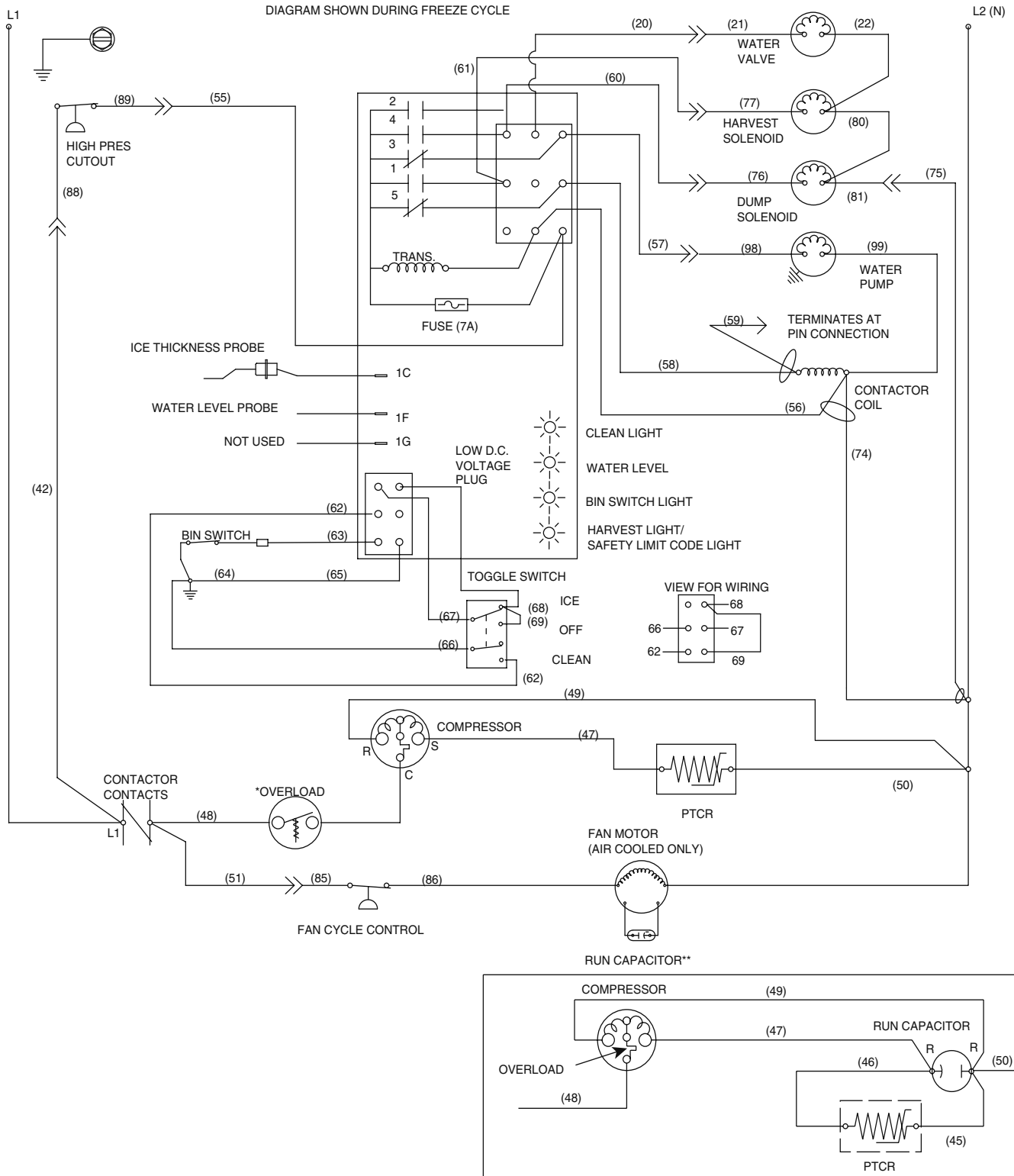

SV2070



**Q420/Q450/Q600/Q800/Q1000 - SELF CONTAINED -  
1 PHASE WITH TERMINAL BOARD**

CAUTION: DISCONNECT POWER BEFORE WORKING  
ON ELECTRICAL CIRCUITRY.  
DIAGRAM SHOWN DURING FREEZE CYCLE

SEE SERIAL PLATE FOR VOLTAGE

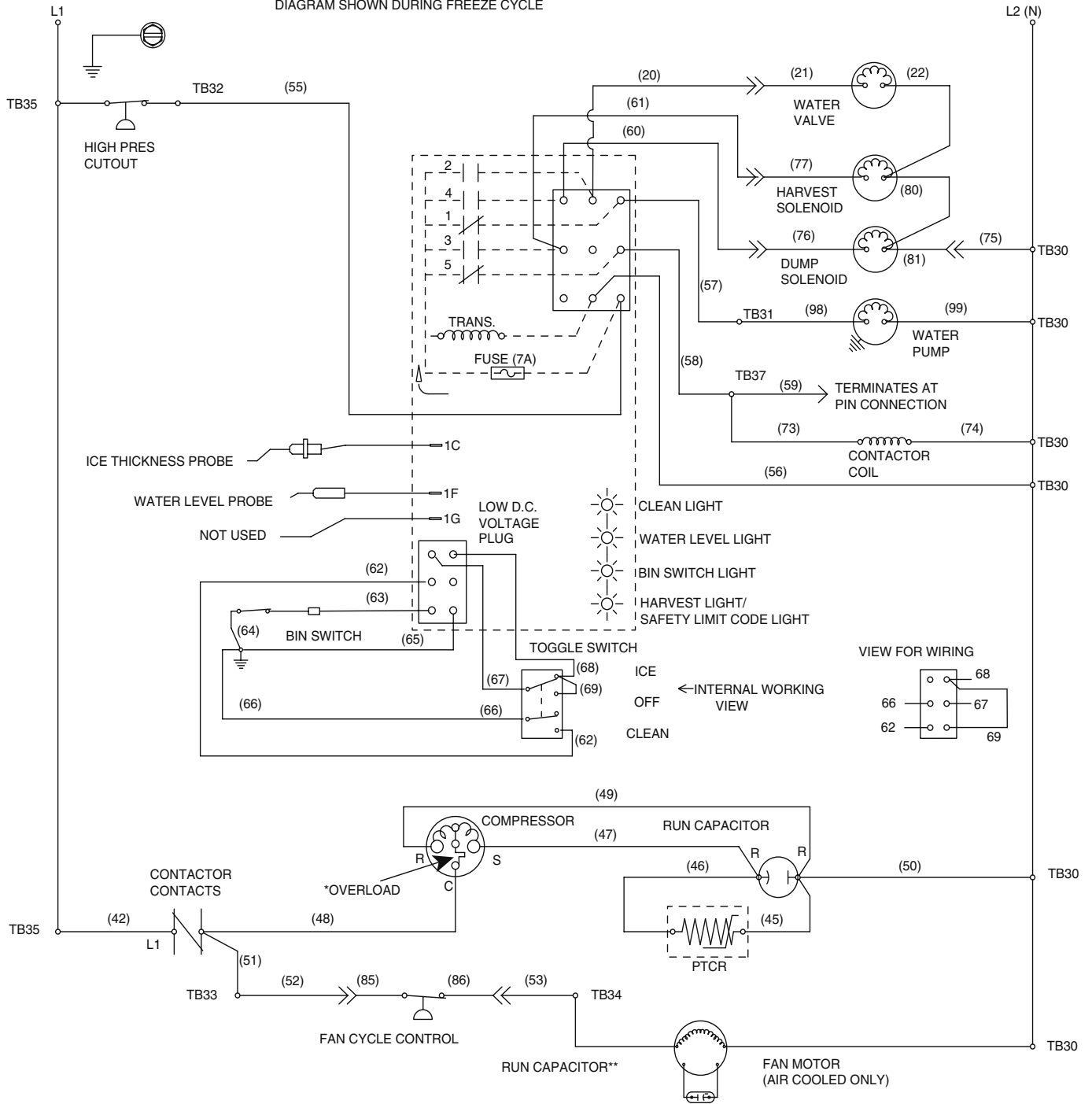

SV1646

**Q420/Q450/Q600/Q800/Q1000 - SELF CONTAINED -  
1 PHASE WITHOUT TERMINAL BOARD**

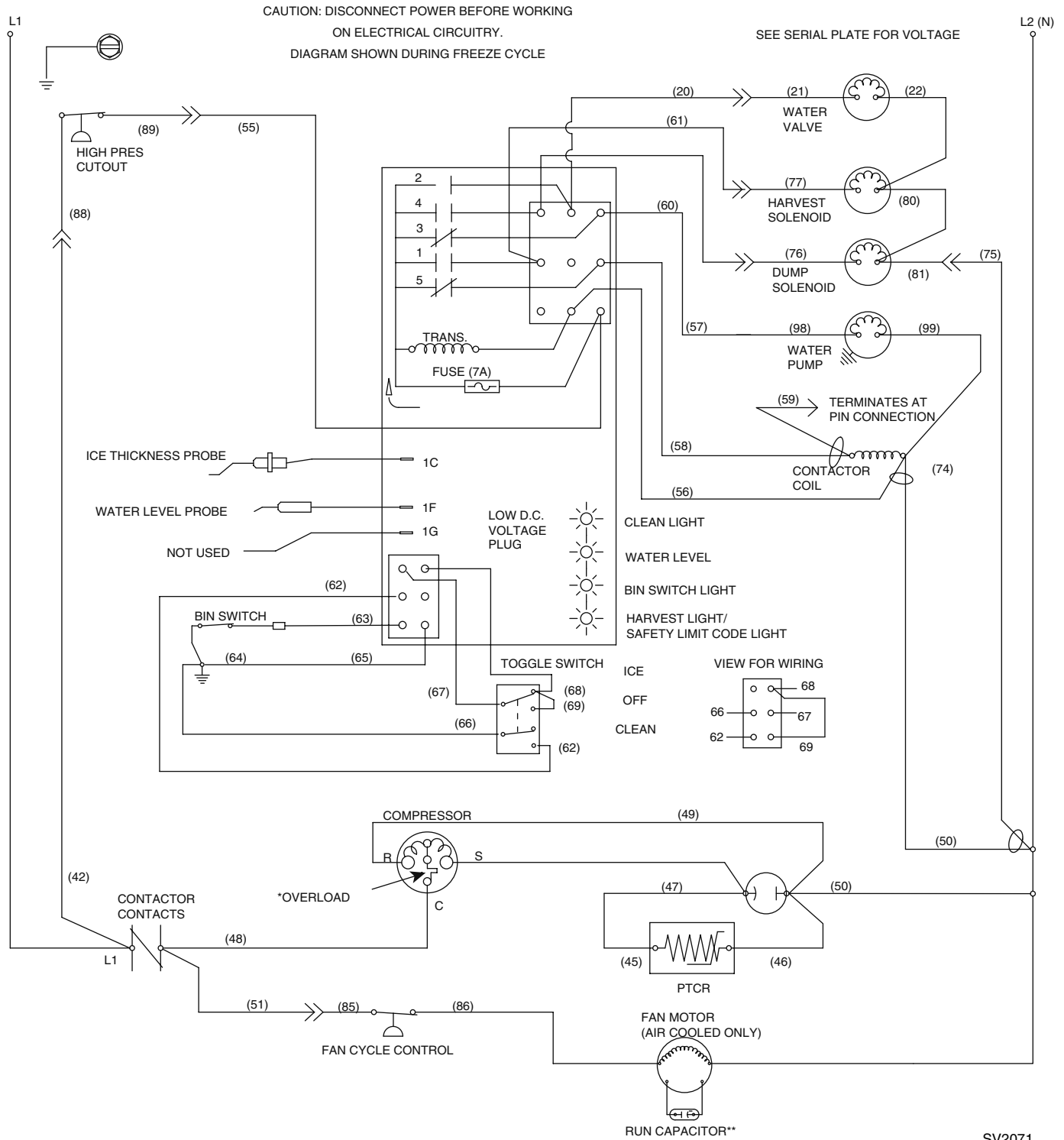

SV2071

Q800/Q1000 - SELF CONTAINED - 3 PHASE WITH TERMINAL BOARD

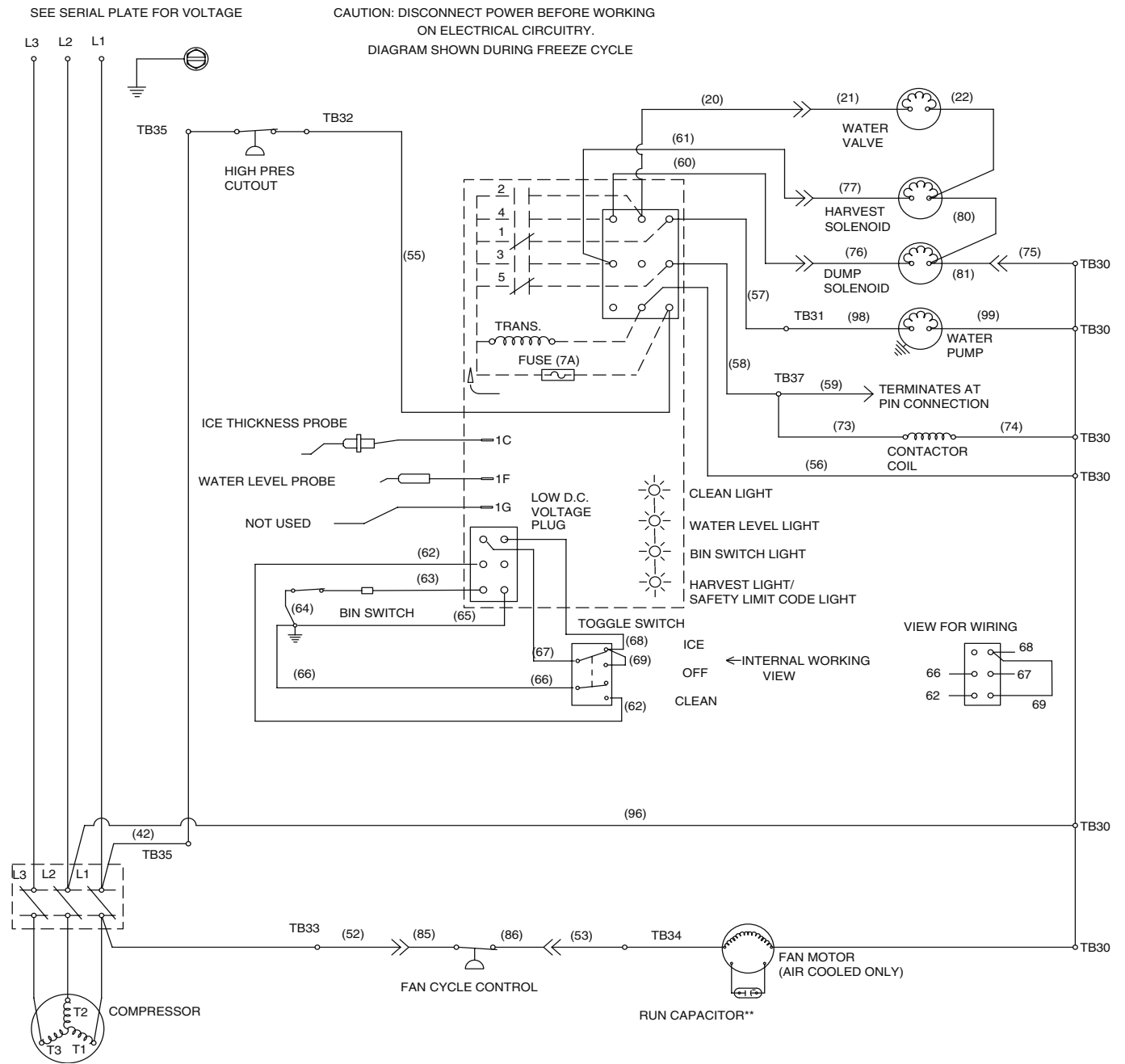

SV1647a

**Q800/Q1000 - SELF CONTAINED - 3 PHASE WITHOUT TERMINAL BOARD**

CAUTION: DISCONNECT POWER BEFORE WORKING  
ON ELECTRICAL CIRCUITRY.  
DIAGRAM SHOWN DURING FREEZE CYCLE  
SEE SERIAL PLATE FOR VOLTAGE

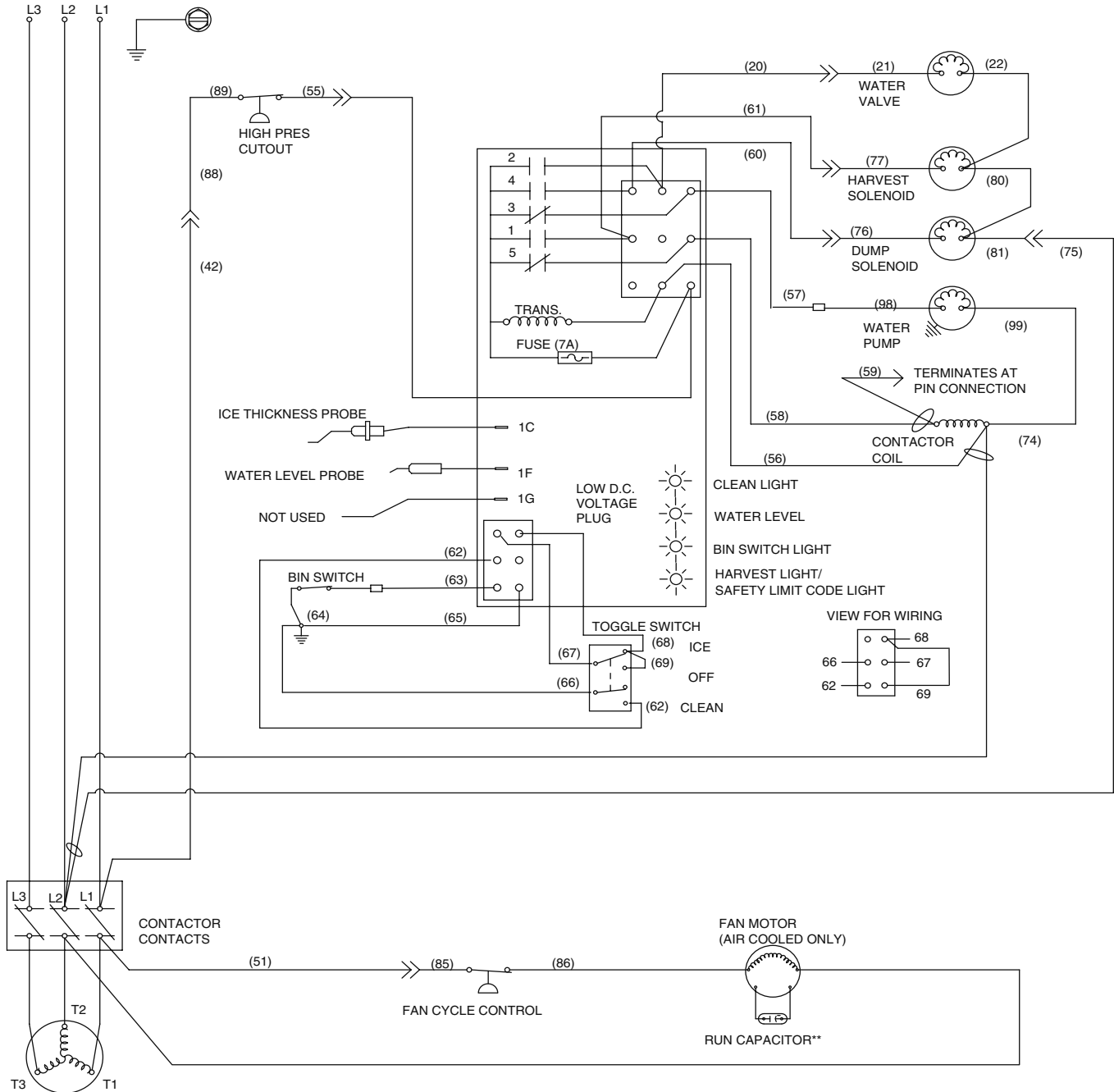

SV2072

Q1300/Q1800 - SELF CONTAINED - 1 PHASE WITH TERMINAL BOARD

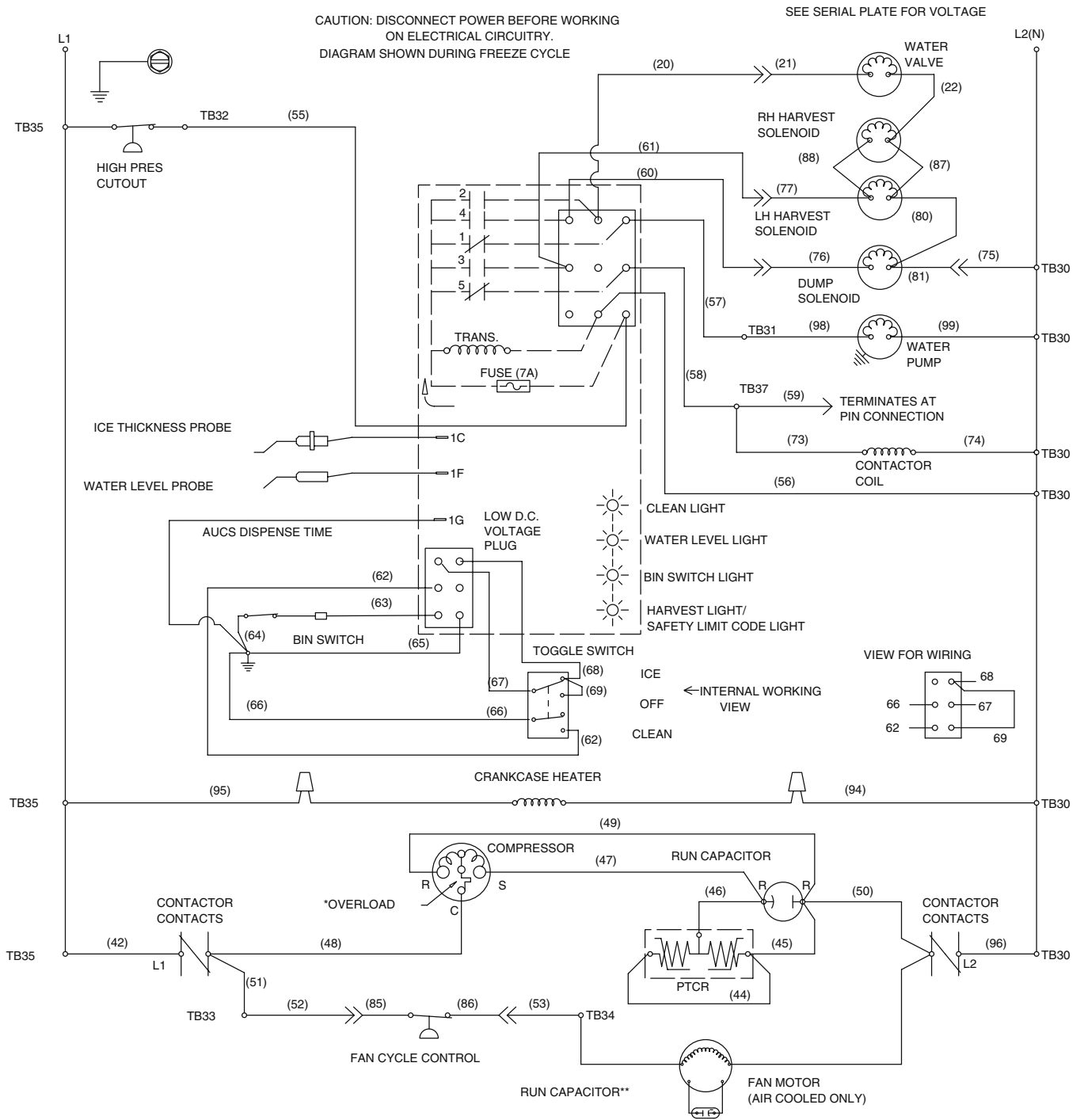

SV1652

Q1300/Q1600/Q1800 - SELF CONTAINED - 1 PHASE WITHOUT TERMINAL BOARD

CAUTION: DISCONNECT POWER BEFORE WORKING ON ELECTRICAL CIRCUITRY.  
 DIAGRAM SHOWN DURING FREEZE CYCLE

SEE SERIAL PLATE FOR VOLTAGE

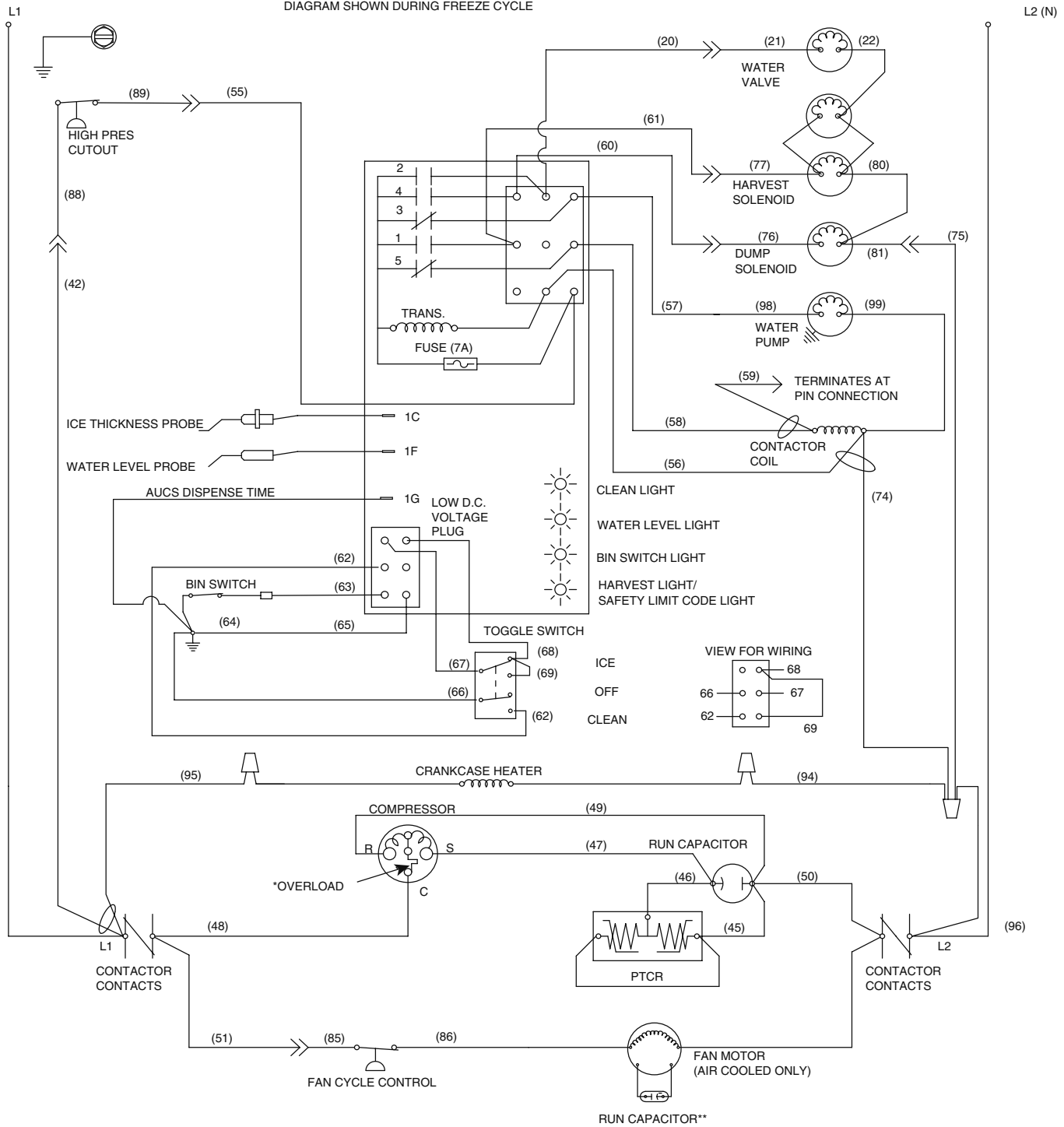

SV2075

Q1300/Q1800 - SELF CONTAINED - 3 PHASE WITH TERMINAL BOARD

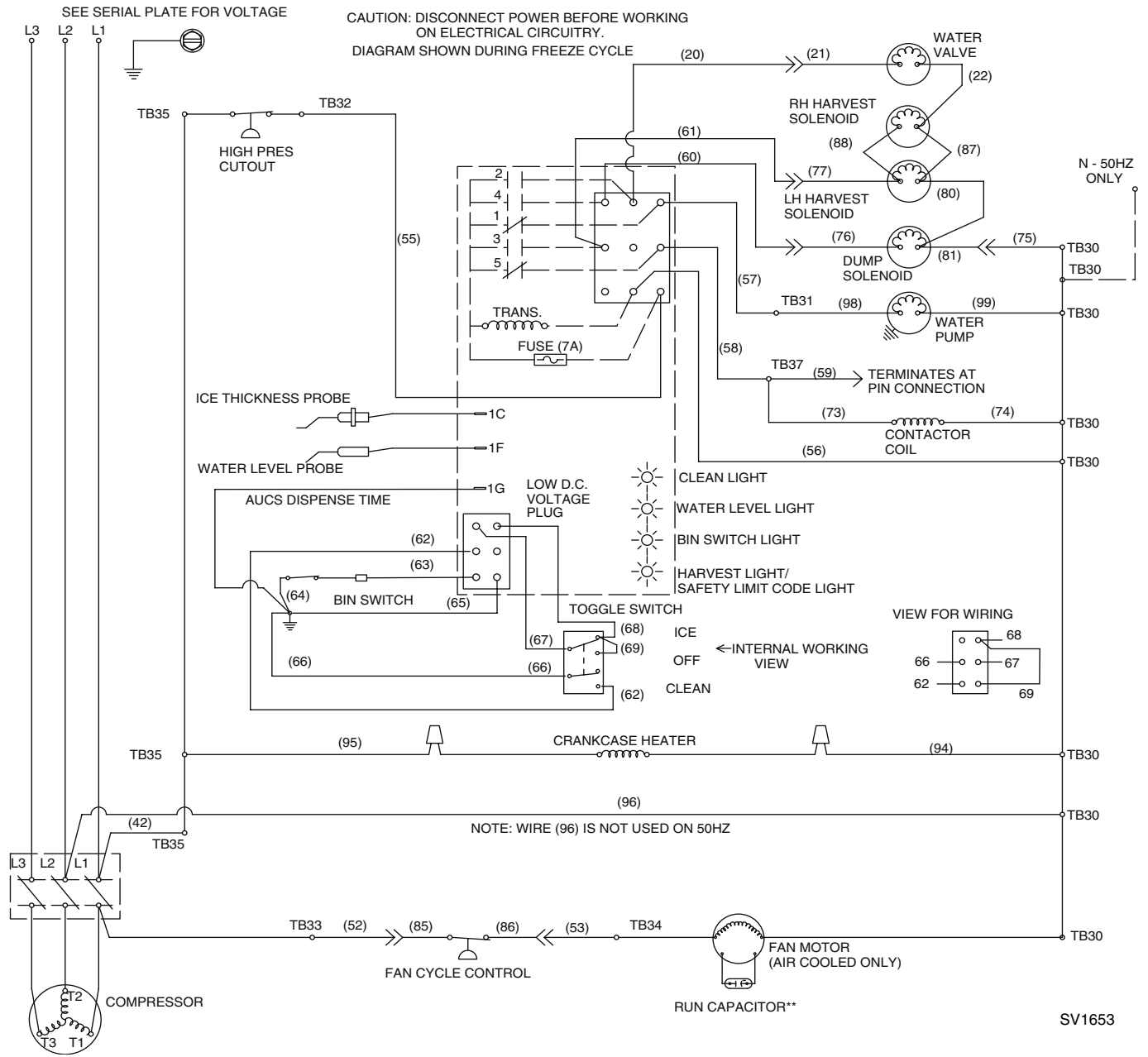

Q1300/Q1600/Q1800 - SELF CONTAINED - 3 PHASE WITHOUT TERMINAL BOARD

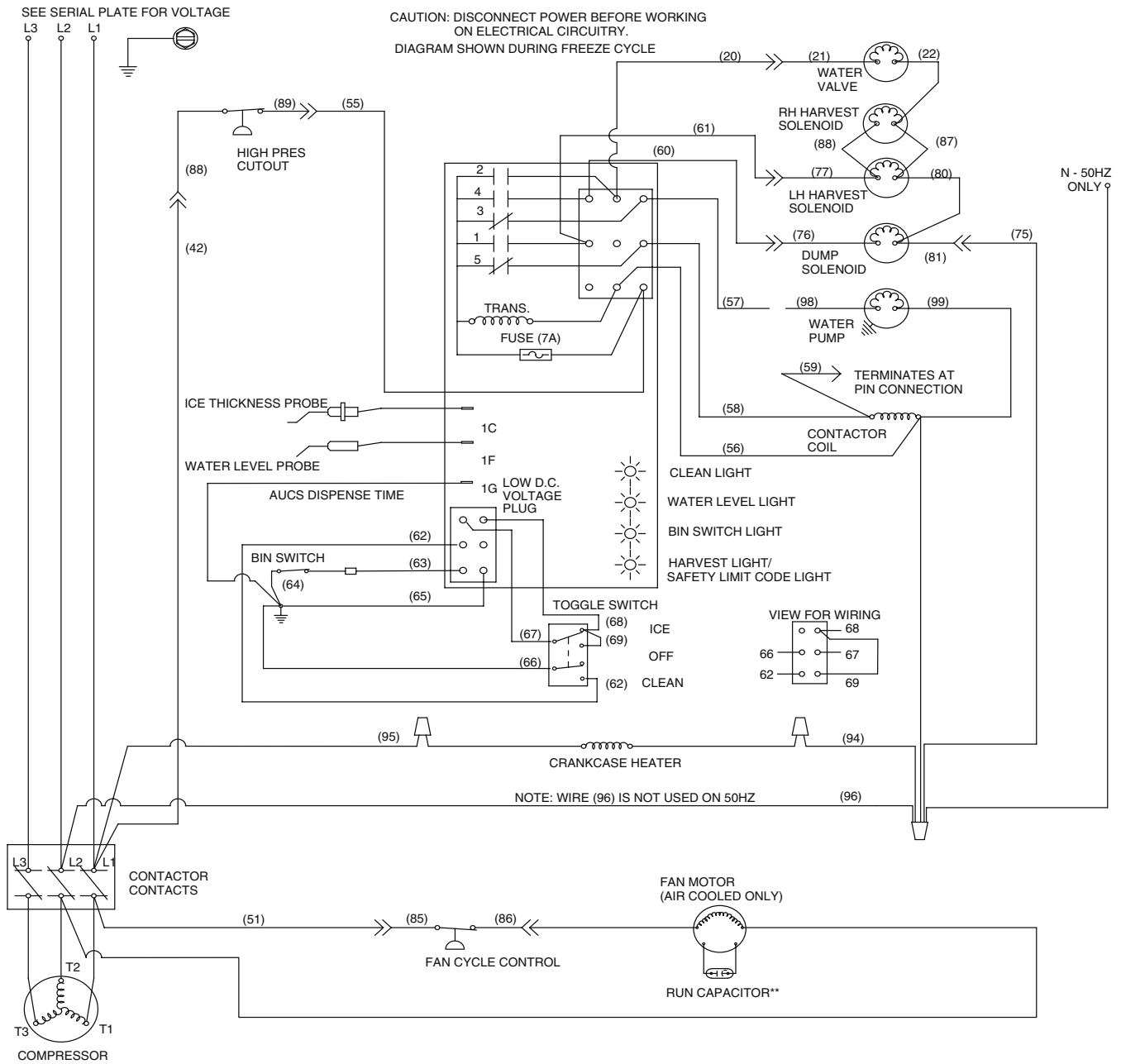

SV3008



Q450/Q600/Q800/Q1000 - REMOTE - 1 PHASE WITH TERMINAL BOARD

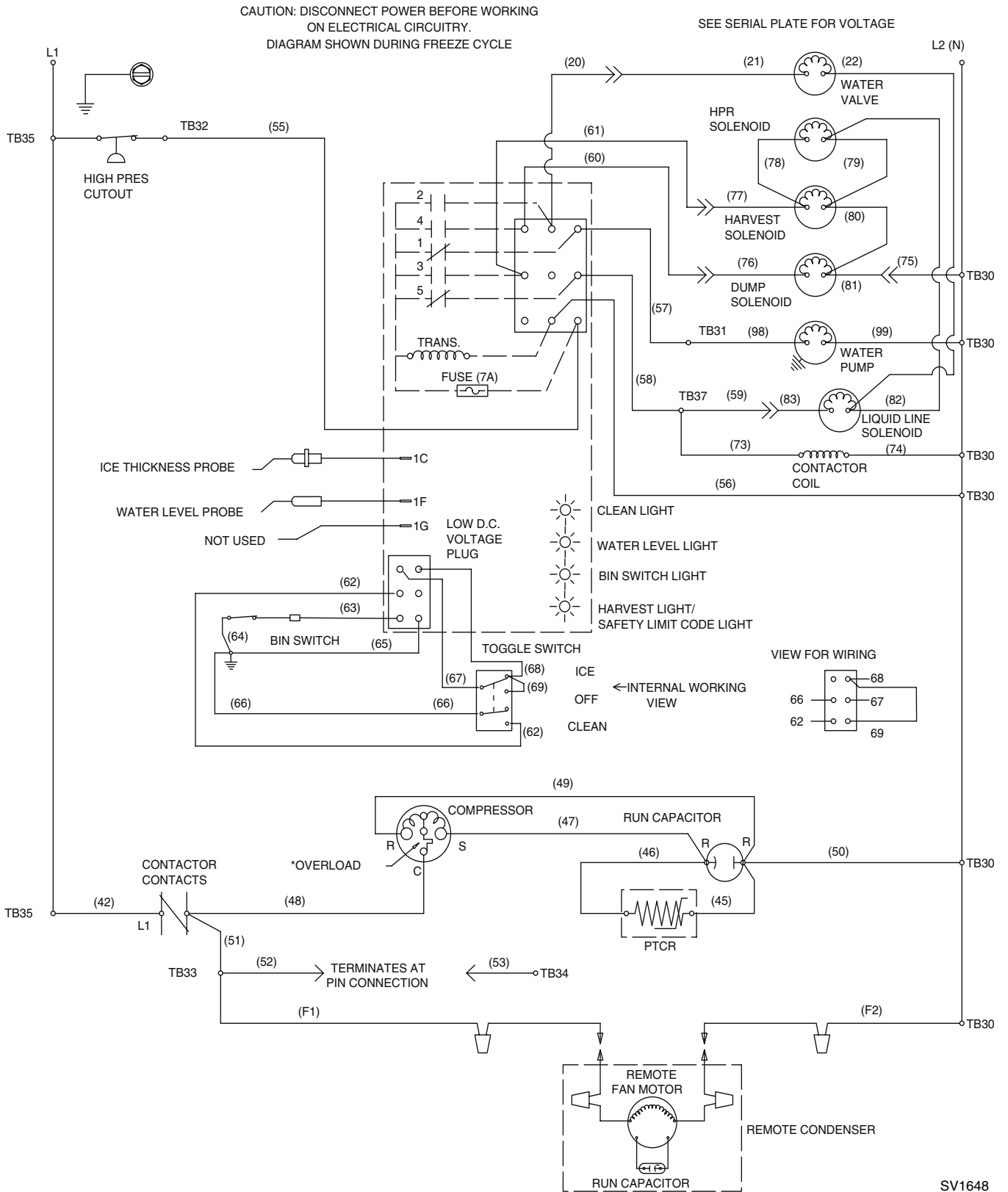

SV1648

Q450/Q600/Q800/Q1000 - REMOTE - 1 PHASE WITHOUT TERMINAL BOARD

CAUTION: DISCONNECT POWER BEFORE WORKING ON ELECTRICAL CIRCUITRY.

SEE SERIAL PLATE FOR VOLTAGE

DIAGRAM SHOWN DURING FREEZE CYCLE

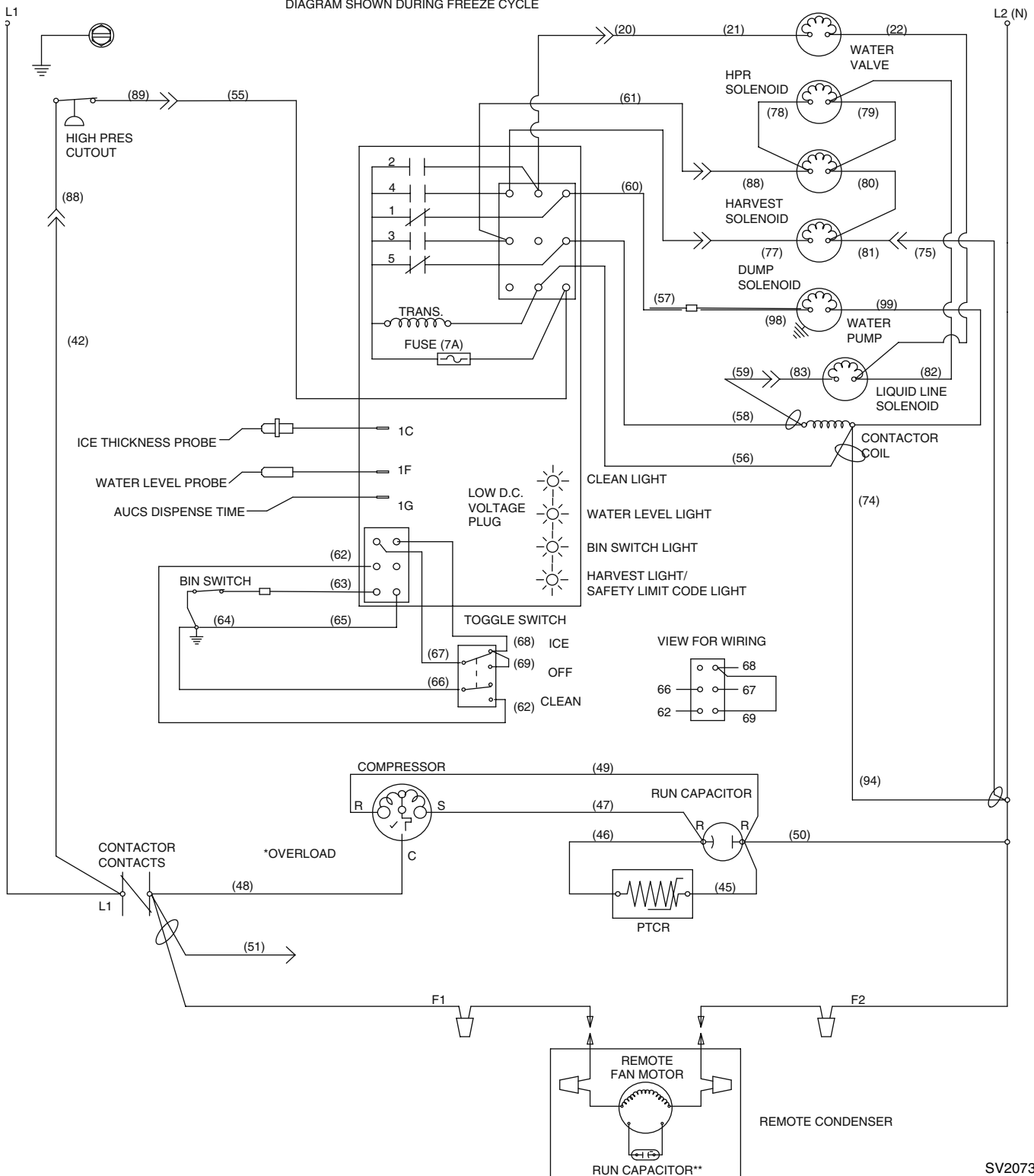

SV2073

Q800/Q1000 -REMOTE - 3 PHASE WITH TERMINAL BOARD

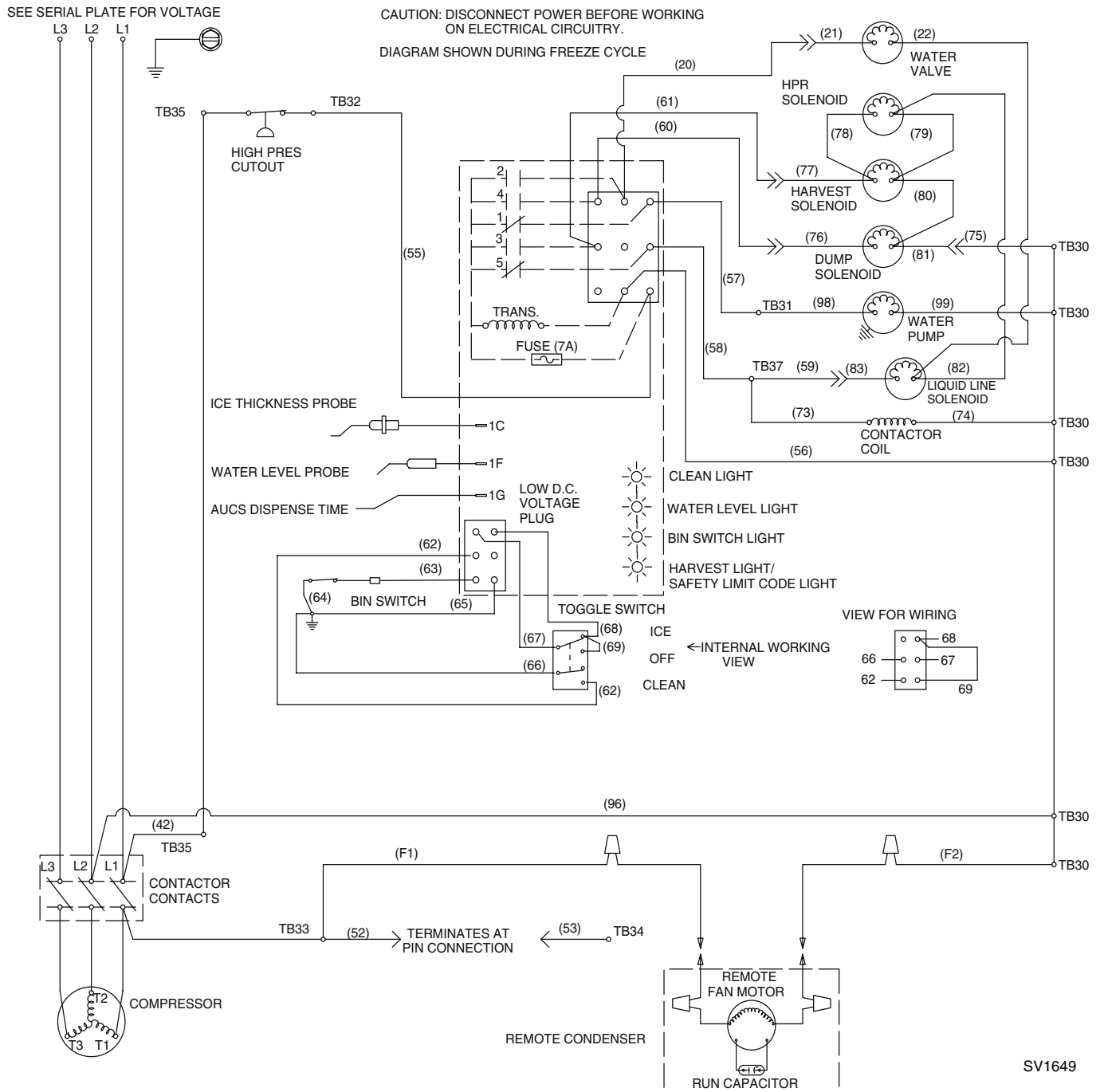

Q800/Q1000 -REMOTE - 3 PHASE WITHOUT TERMINAL BOARD

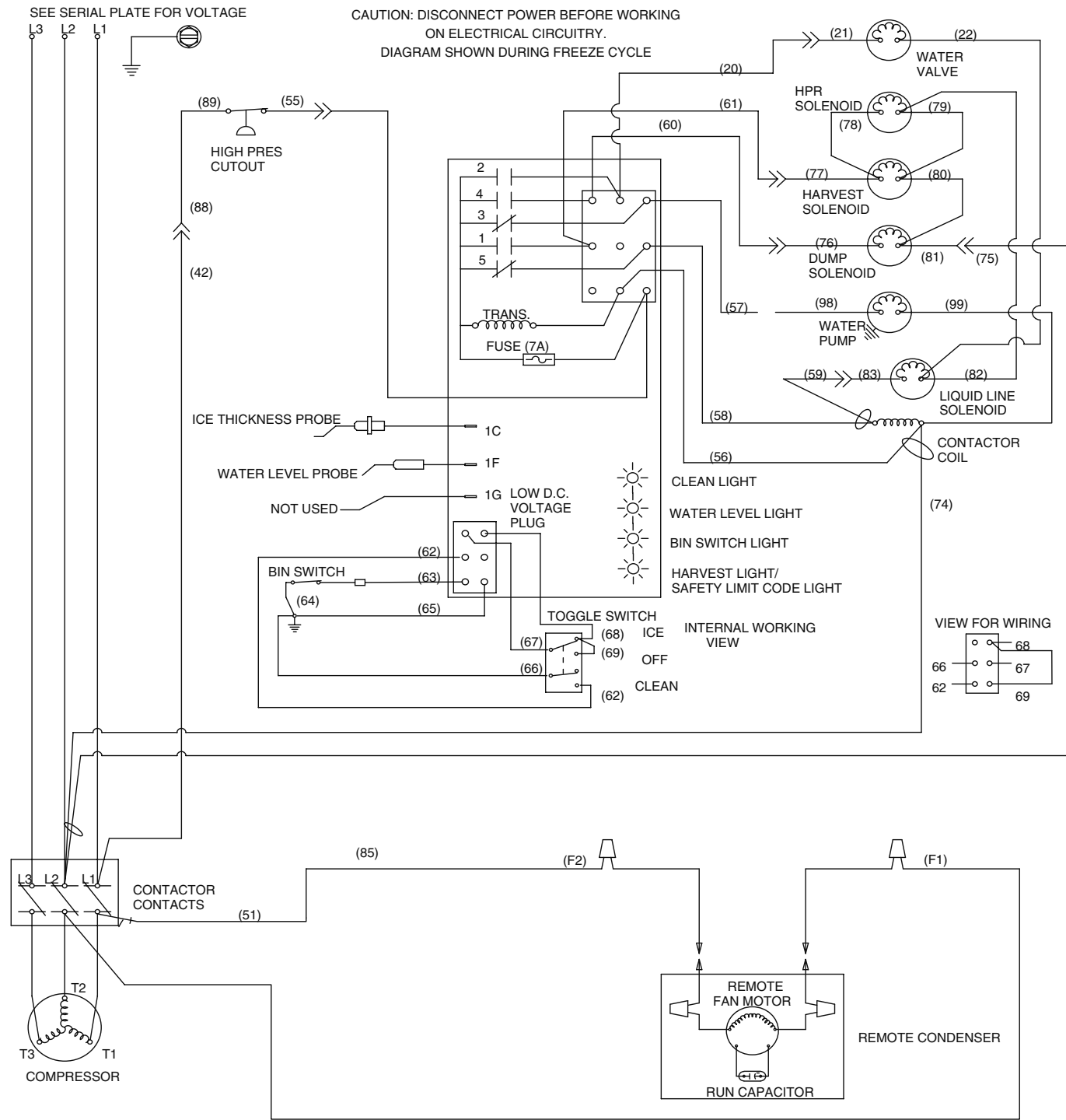

SV2074

Q1300/Q1800 - REMOTE - 1 PHASE WITH TERMINAL BOARD

CAUTION: DISCONNECT POWER BEFORE WORKING ON ELECTRICAL CIRCUITRY.  
 DIAGRAM SHOWN DURING FREEZE CYCLE

SEE SERIAL PLATE FOR VOLTAGE

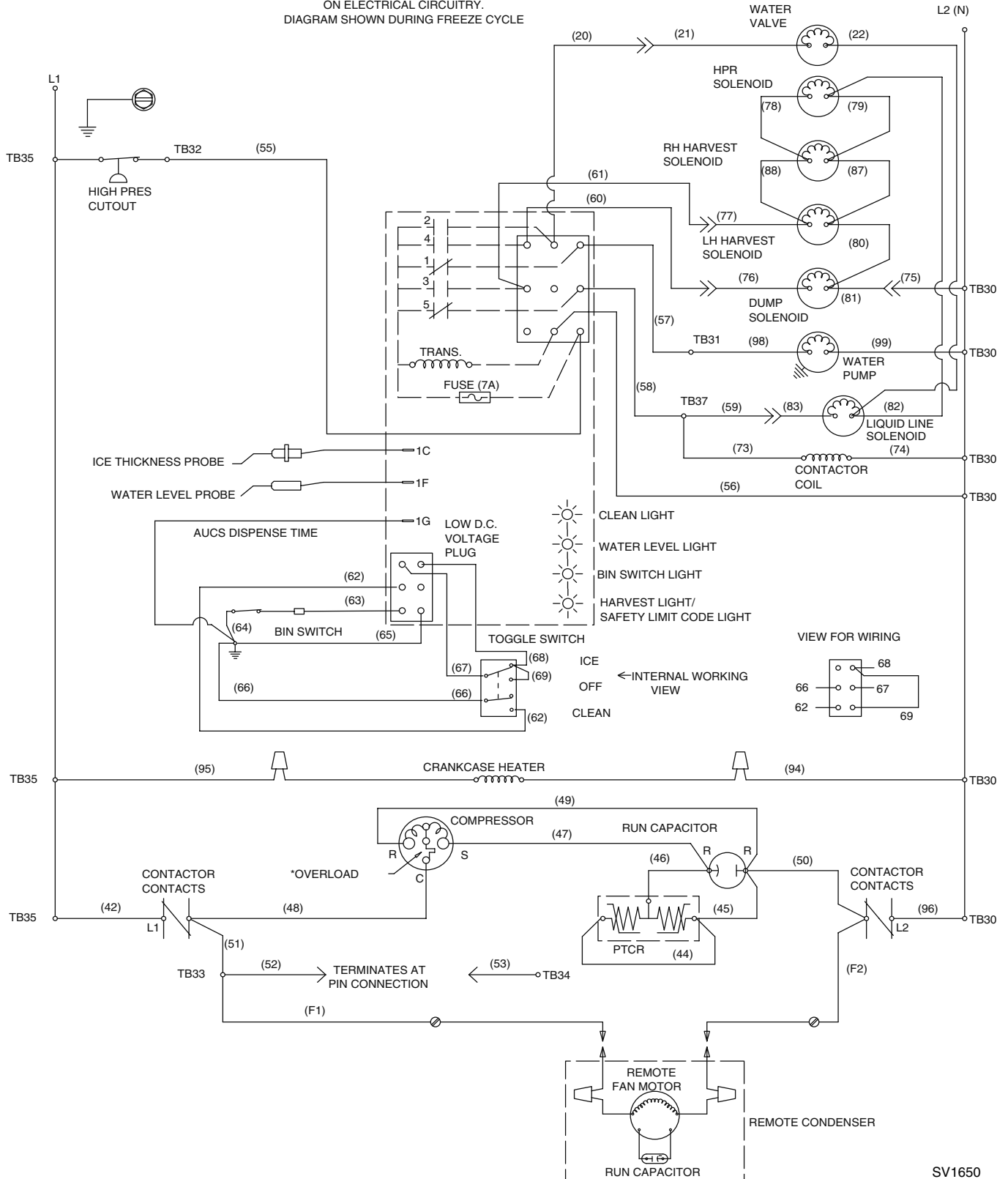

Q1300/Q1600/Q1800 - REMOTE - 1 Phase Without Terminal Board

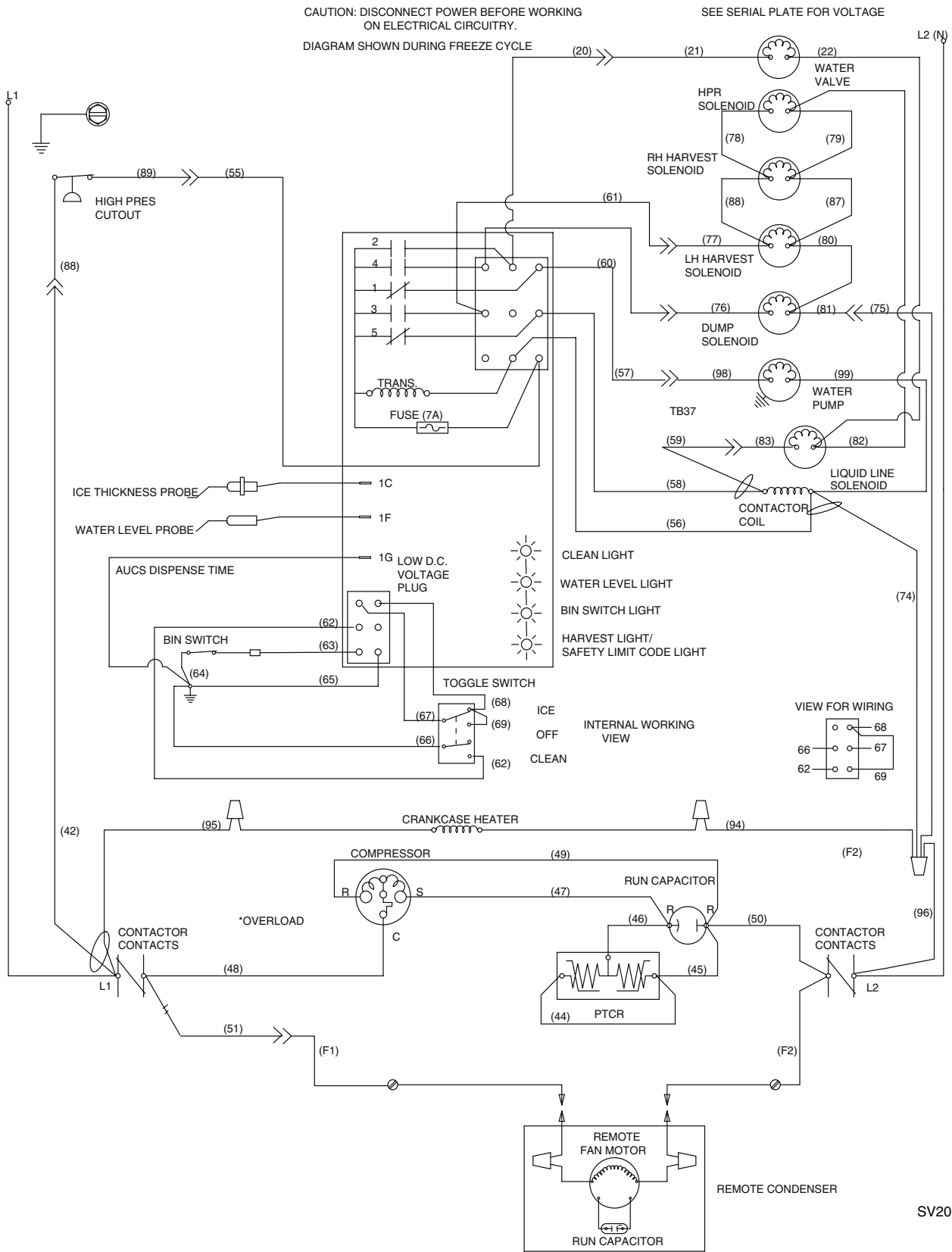

SV2076

Q1300/Q1800 - REMOTE - 3 PHASE WITH TERMINAL BOARD

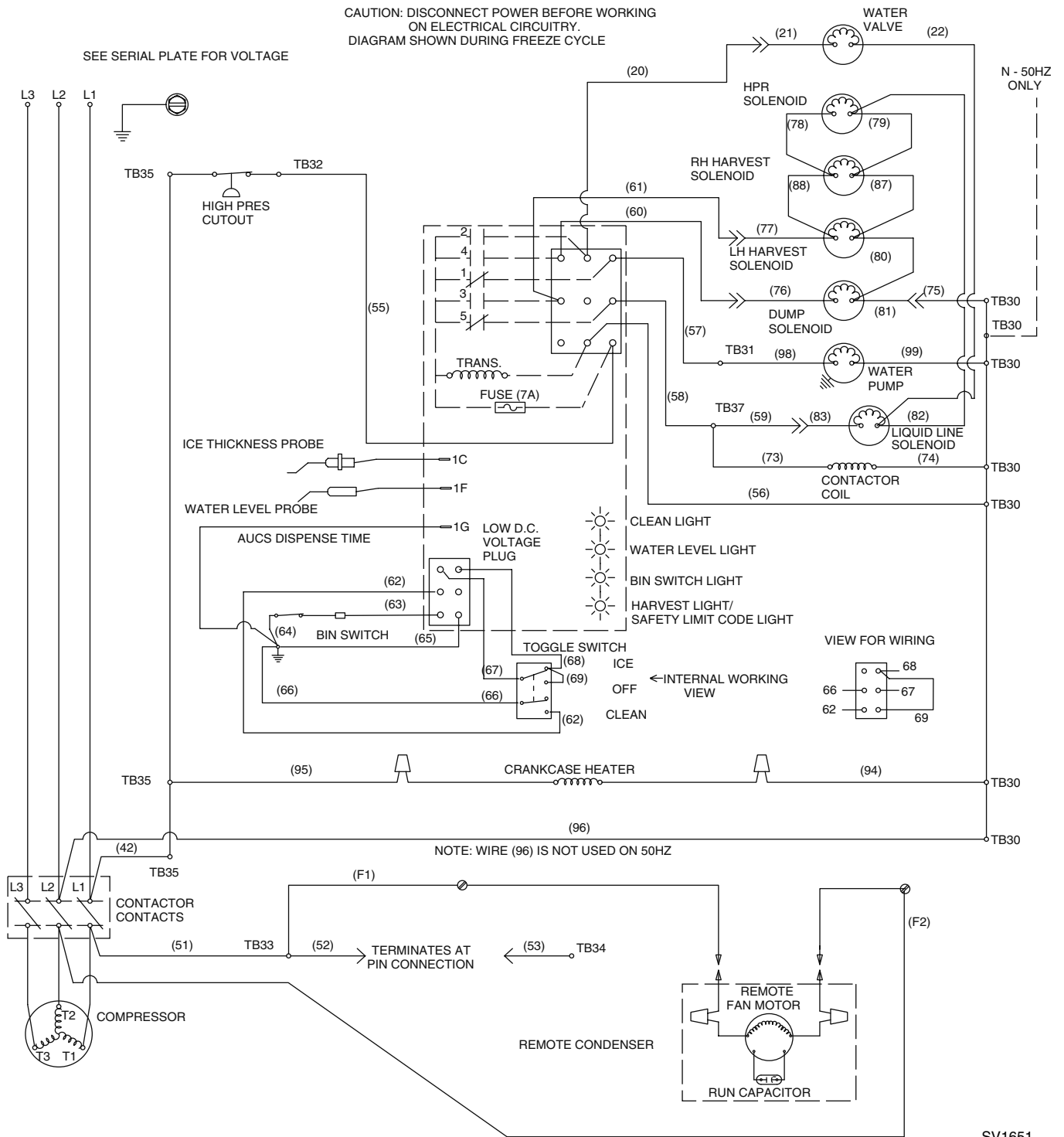

Q1300/Q1600/Q1800 - REMOTE - 3 PHASE WITHOUT TERMINAL BOARD

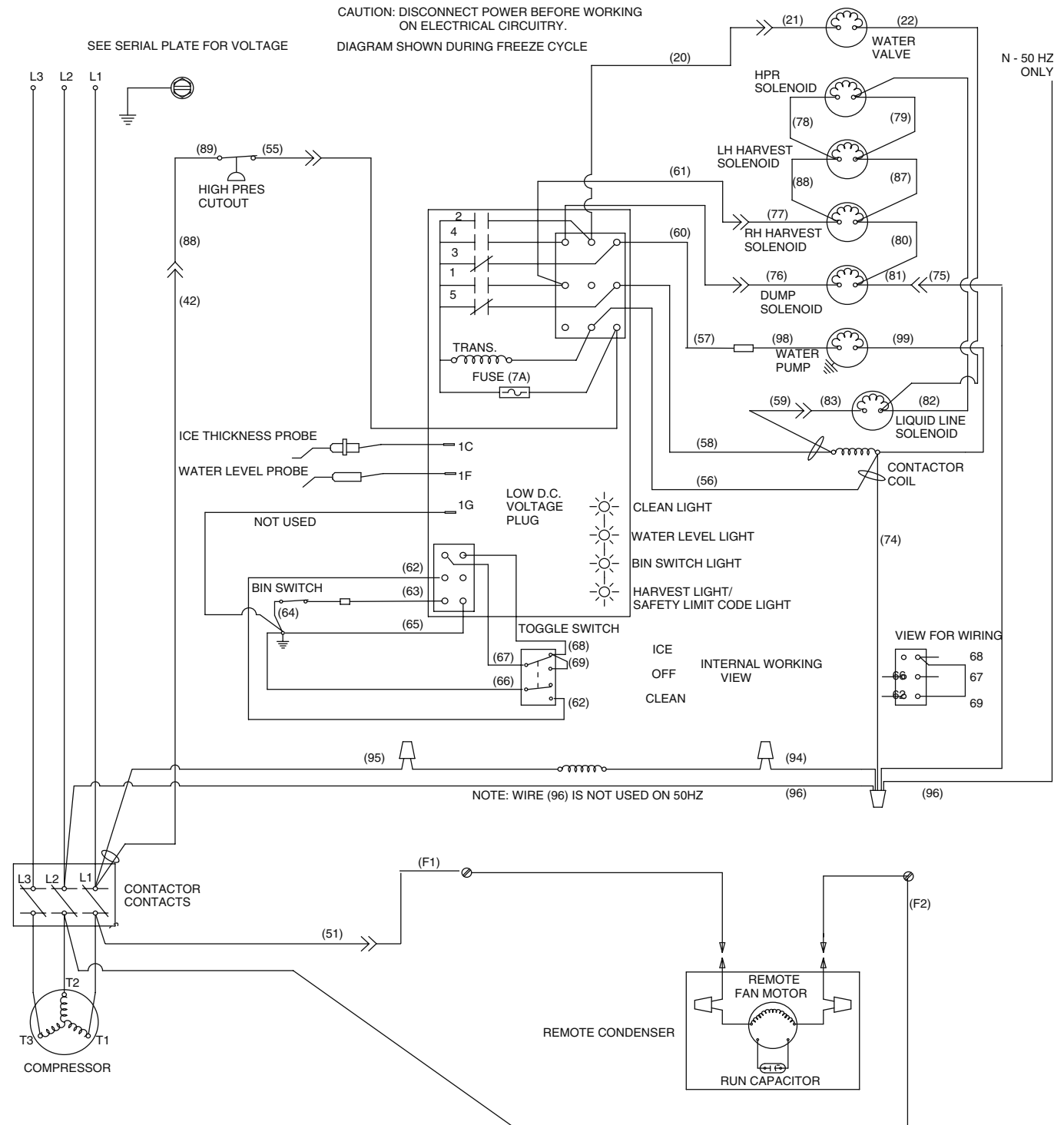

SV2077



THIS PAGE INTENTIONALLY LEFT BLANK

**Component Specifications and Diagnostics**

**MAIN FUSE**

**Function**

The control board fuse stops ice machine operation if electrical components fail causing high amp draw.

**Specifications**

The main fuse is 250 Volt, 7 amp.

**Check Procedure**

**Warning**

High (line) voltage is applied to the control board (terminals #55 and #56) at all times. Removing the control board fuse or moving the toggle switch to OFF will not remove the power supplied to the control board.

1. If the bin switch light is on with the water curtain closed, the fuse is good.

**Warning**

Disconnect electrical power to the entire ice machine before proceeding.

2. Remove the fuse. Check the resistance across the fuse with an ohm meter.

| Reading    | Result       |
|------------|--------------|
| Open (OL)  | Replace fuse |
| Closed (O) | Fuse is good |

**BIN SWITCH**

**Function**

Movement of the water curtain controls bin switch operation. The bin switch has two main functions:

1. Terminating the harvest cycle and returning the ice machine to the freeze cycle.

This occurs when the bin switch is opened and closed again within 7 seconds during the harvest cycle.

2. Automatic ice machine shut-off.

If the storage bin is full at the end of a harvest cycle, the sheet of cubes fails to clear the water curtain and holds it open. After the water curtain is held open for 7 seconds, the ice machine shuts off. The ice machine remains off until enough ice is removed from the storage bin to allow the sheet of cubes to drop clear of the water curtain. As the water curtain swings back to the operating position, the bin switch closes and the ice machine restarts, provide the three-minute delay has expired.

**Important**

The water curtain must be ON (bin switch(s) closed) to start ice making.

**Specifications**

The bin switch is a magnetically operated reed switch. The magnet is attached to the lower right corner of the water curtain. The switch is attached to the evaporator-mounting bracket.

The bin switch is connected to a varying D.C. voltage circuit. (Voltage does not remain constant.)

NOTE: Because of a wide variation in D.C. voltage, it is not recommended that a voltmeter be used to check bin switch operation.

**Check Procedure**

1. Set the toggle switch to OFF.
2. Watch the bin switch light on the control board.
3. Move the water curtain toward the evaporator. The bin switch must close. The bin switch light "on" indicates the bin switch has closed properly.

Move the water curtain away from the evaporator. The bin switch must open. The bin switch light "off" indicates the bin switch has opened properly.

**OHM Test**

1. Disconnect the bin switch wires to isolate the bin switch from the control board.
2. Connect an ohmmeter to the disconnected bin switch wires.
3. Cycle the bin switch open and closed numerous times by opening and closing the water curtain.

NOTE: To prevent misdiagnosis:

- Always use the water curtain magnet to cycle the switch (a larger or smaller magnet will affect switch operation).
- Watch for consistent readings when the bin switch is cycled open and closed (bin switch failure could be erratic).

**Water Curtain Removal Notes**

The water curtain must be on (bin switch closed) to start ice making. While a freeze cycle is in progress, the water curtain can be removed and installed at any time without interfering with the electrical control sequence.

If the ice machine goes into harvest sequence while the water curtain is removed, one of the following will happen:

- **Water curtain remains off:**  
When the harvest cycle time reaches 3.5 minutes and the bin switch is not closed, the ice machine stops as though the bin were full.
- **Water curtain is put back on:**  
If the bin switch closes prior to reaching the 3.5-minute point, the ice machine immediately returns to another freeze sequence prechill.

**COMPRESSOR ELECTRICAL DIAGNOSTICS**

The compressor will not start or will trip repeatedly on overload.

**Check Resistance (Ohm) Values**

NOTE: Compressor windings can have very low ohm values. Use a properly calibrated meter.

Perform the resistance test after the compressor cools. The compressor dome should be cool enough to touch (below 120°F/49°C) to assure that the overload is closed and the resistance readings will be accurate.

**SINGLE PHASE COMPRESSORS**

1. Disconnect power from the cuber and remove the wires from the compressor terminals.
2. The resistance values must be within published guidelines for the compressor. The resistance values between C and S and between C and R, when added together, should equal the resistance value between S and R.
3. If the overload is open, there will be a resistance reading between S and R, and open readings between C and S and between C and R. Allow the compressor to cool, then check the readings again.

**THREE PHASE COMPRESSORS**

1. Disconnect power from the cuber and remove the wires from the compressor terminals.
2. The resistance values must be within published guidelines for the compressor. The resistance values between L1 and L2, between L2 and L3, and between L3 and L1 should all be equal.
3. If the overload is open, there will be open readings between L1 and L2, between L2 and L3, and between L3 and L1. Allow the compressor to cool, then check the readings again.

**Check Motor Windings to Ground**

Check continuity between all three terminals and the compressor shell or copper refrigeration line. Scrape metal surface to get good contact. If continuity is present, the compressor windings are grounded and the compressor should be replaced.

**Determine if the Compressor is Seized**

Check the amp draw while the compressor is trying to start.

**COMPRESSOR DRAWING LOCKED ROTOR**

The two likely causes of this are:

- Defective starting component
- Mechanically seized compressor

To determine which you have:

1. Install high and low side gauges.
2. Try to start the compressor.
3. Watch the pressures closely.
  - A. If the pressures do not move, the compressor is seized. Replace the compressor.
  - B. If the pressures move, the compressor is turning slowly and is not seized. Check the capacitors and start relay.

**COMPRESSOR DRAWING HIGH AMPS**

The continuous amperage draw on start-up should not be near the maximum fuse size indicated on the serial tag.

The voltage when the compressor is trying to start must be within  $\pm 10\%$  of the nameplate voltage.

**Diagnosing Capacitors**

- If the compressor attempts to start, or hums and trips the overload protector, check the starting components before replacing the compressor.
- Visual evidence of capacitor failure can include a bulged terminal end or a ruptured membrane. Do not assume a capacitor is good if no visual evidence is present.
- A good test is to install a known good substitute capacitor.
- Use a capacitor tester when checking a suspect capacitor. Clip the bleed resistor off the capacitor terminals before testing.

**PTCR DIAGNOSTICS****What is a PTCR?**

A PTCR (or Positive Temperature Coefficient Resistor) is made from high-purity, semi-conducting ceramics.

A PTCR is useful because of its resistance versus temperature characteristic. The PTCR has a low resistance over a wide (low) temperature range, but upon reaching a certain higher temperature, its resistance greatly increases, virtually stopping current flow. When the source of heat is removed, the PTCR returns to its initial base resistance.

In severe duty cycles, it can be used to repeatedly switch (virtually stop) large currents at line voltages.

PTCR's have been used for many years in millions of HVAC applications. In place of using the conventional start relay/start capacitor, a simple PTCR provides the starting torque assistance to PSC (Permanent Split Capacitor) single-phase compressors, which can equalize pressures before starting.

**Compressor Start Sequence**

PTCR's provide additional starting torque by increasing the current in the auxiliary (start) winding during starting. The PTCR is wired across the run capacitor (in series with the start winding).

1. It is important for the refrigerant discharge and suction pressures to be somewhat equalized prior to the compressor starting. To assure equalization of pressures the harvest valve (and HPR valve on remotes) will energize for 45 seconds prior to compressor starting. The harvest valve (and HPR valve on remotes) remains on for an additional 5 seconds while the compressor is starting.
2. When starting the compressor, the contactor closes and the PTCR, which is at a low resistance value, allows high starting current to flow in the start winding.
3. The current passing through the PTCR causes it to rapidly heat up, and after approximately .25-1 second it abruptly "switches" to a very high resistance, virtually stopping current flow through it.
4. At this point the motor is up to speed and all current going through the start winding will now pass through the run capacitor.
5. The PTCR remains hot and at a high resistance as long as voltage remains on the circuit.
6. It is important to provide time between compressor restarts to allow the PTCR to cool down to near its initial temperature (low resistance). When the contactor opens to stop the compressor, the PTCR cools down to its initial low resistance and is again ready to provide starting torque assistance. To assure the PTCR has cooled down, during an automatic shut-off, the Q model ice machines have a built-in 3-minute off time before it can restart.

**Q-Model Automatic Shut-Off and Restart**

When the storage bin is full at the end of a harvest cycle, the sheet of cubes fails to clear the water curtain and will hold it open. After the water curtain is held open for 7 seconds, the ice machine shuts off. To assure the PTCR has cooled, the ice machine remains off for 3 minutes before it can automatically restart.

The ice machine remains off until enough ice has been removed from the storage bin to allow the ice to fall clear of the water curtain. As the water curtain swings back to operating position, the bin switch closes and the ice machine restarts, provided the three-minute delay period is complete.

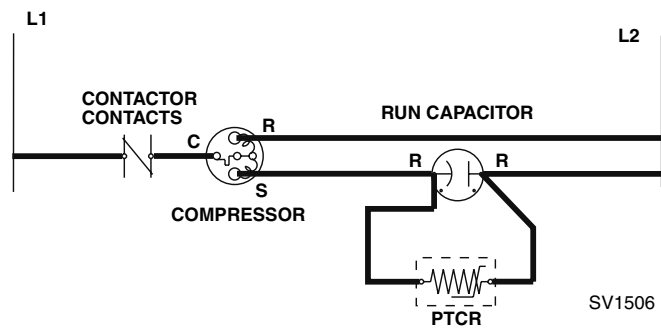

**Figure 6-15. During Start-Up (First .25 - 1.0 Seconds)**

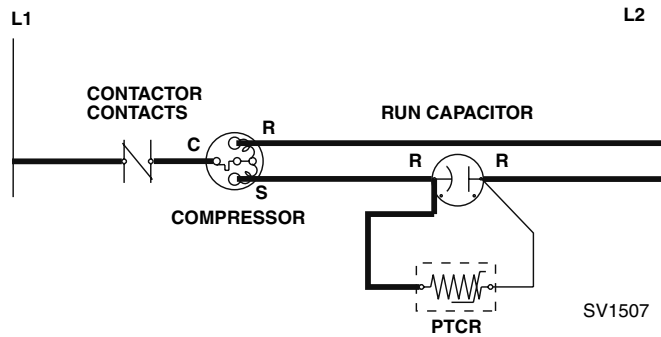

**Figure 6-16. After Start-Up  
(Current Flows Through Run Capacitor)**

**Troubleshooting PTCR's**

WHY A GOOD PTCR MAY FAIL TO START THE COMPRESSOR

The PTCR must be cooled before attempting to start the compressor, otherwise the high starting torque may not last long enough.

For example, if the PTCR is properly cooled, say 60°F (15.6°C) when the compressor starts, it will take .25 to 1.0 seconds before its temperature reaches 260°F (126.6°C), and current flow is stopped.

If the PTCR is still warm, say 160°F (71.1°C) when the compressor starts, it will take only .125 to .50 seconds before its temperature reaches 260°F (126.6°C), and current flow is stopped. This decreased time may be insufficient to start the compressor.

A good PTCR may be too hot to operate properly at start-up because:

- The ice machine's 3-minute delay has been overridden. Opening and closing the service disconnect or cycling the toggle switch from OFF to ICE will override the delay period.
- The control box temperature is too high. Though rare, very high air temperatures (intense sunlight, etc.) can greatly increase the temperature of the control box and its contents. This may require a longer off time to allow the PTCR to cool.
- The compressor has short-cycled, or the compressor overload has opened. Move the toggle switch to OFF and allow the compressor and PTCR to cool.

Continued on next page ...

There are other problems that may cause compressor start-up failure with a good PTCR in a new, properly wired ice machine.

- The voltage at the compressor during start-up is too low.

Manitowoc ice machines are rated at  $\pm 10\%$  of nameplate voltage at compressor start-up. (Ex: An ice machine rated at 208-230 should have a compressor start-up voltage between 187 and 253 volts.)

- The compressor discharge and suction pressures are not matched closely enough or equalized.

These two pressures must be somewhat equalized before attempting to start the compressor. The harvest valve (and HPR valve on remotes) energizes for 45 seconds before the compressor starts, and remains on 5 seconds after the compressor starts. Make sure this is occurring and the harvest valve (and HPR solenoid) coil is functional before assuming that the PTCR is bad.

**CHECKING THE PTCR**

**Warning**

Disconnect electrical power to the entire ice machine at the building electrical disconnect box before proceeding.

1. Visually inspect the PTCR. Check for signs of physical damage.

NOTE: The PTCR case temperature may reach 210°F (100°C) while the compressor is running. This is normal. Do not change a PTCR just because it is hot.

2. Wait at least 10 minutes for the PTCR to cool to room temperature.
3. Remove the PTCR from the ice machine.
4. Measure the resistance of the PTCR as shown below. If the resistance falls outside of the acceptable range, replace it.

| Model                                | Manitowoc Part Number | Cera-Mite Part Number | Room Temperature Resistance |
|--------------------------------------|-----------------------|-----------------------|-----------------------------|
| Q200<br>Q280<br>Q320<br>Q420<br>Q450 | 8505003               | 305C20                | 22-50 Ohms                  |
| Q600<br>Q800<br>Q1000                | 8504993               | 305C19                | 18-40 Ohms                  |
| Q1300<br>Q1600<br>Q1800              | 8504913               | 305C9                 | 8-22 Ohms                   |

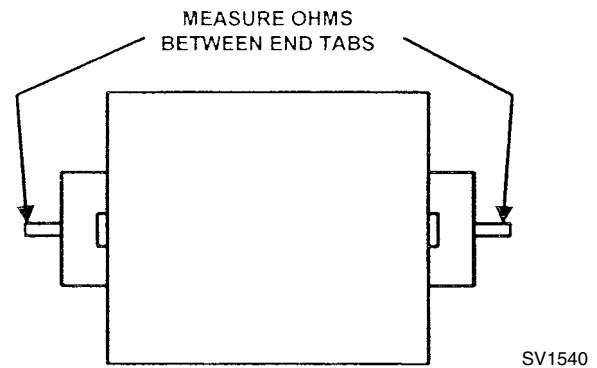

Figure 6-17. Manitowoc PTCR's 8505003 & 8504993

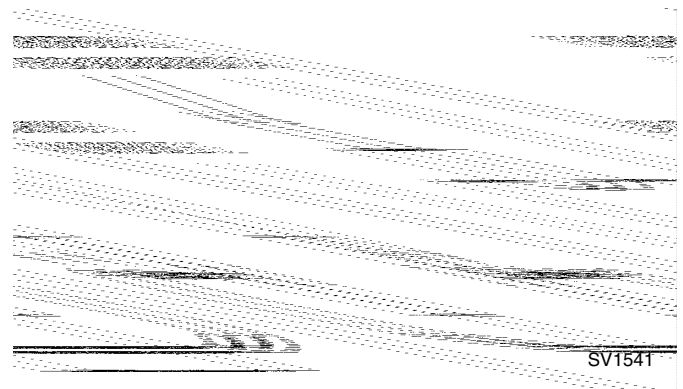

Figure 6-18. Manitowoc PTCR 8504913

**ICE/OFF/CLEAN TOGGLE SWITCH**

**Function**

The switch is used to place the ice machine in ICE, OFF or CLEAN mode of operation.

**Specifications**

Double-pole, double-throw switch. The switch is connected into a varying low D.C. voltage circuit.

**Check Procedure**

NOTE: Because of a wide variation in D.C. voltage, it is not recommended that a volt meter be used to check toggle switch operation.

1. Inspect the toggle switch for correct wiring.
2. Isolate the toggle switch by disconnecting all wires from the switch, or by disconnecting the Molex connector and removing wire #69 from the toggle switch.
3. Check across the toggle switch terminals using a calibrated ohm meter. Note where the wire numbers are connected to the switch terminals, or refer to the wiring diagram to take proper readings.

| Switch Setting | Terminals | Ohm Reading |
|----------------|-----------|-------------|
| ICE            | 66-62     | Open        |
|                | 67-68     | Closed      |
|                | 67-69     | Open        |
| CLEAN          | 66-62     | Closed      |
|                | 67-68     | Open        |
|                | 67-69     | Closed      |
| OFF            | 66-62     | Open        |
|                | 67-68     | Open        |
|                | 67-69     | Open        |

4. Replace the toggle switch if ohm readings do not match all three switch settings.

**CONTROL BOARD RELAYS**

**Function**

The control board relays energize and de-energize system components.

**Specifications**

Relays are not field replaceable. There are five relays on the control board:

| Relay | Controls   |
|-------|--|
| #1    | Water Pump   |
| #2    | Water Inlet Valve  |
| #3    | Harvest Valve / HPR Valve (Remotes)  |
| #4    | Water Dump Valve   |
| #5    | Contactors (Self-Contained)<br>Contactors / Liquid Line Solenoid (Remotes) |



ELECTRONIC CONTROL BOARD

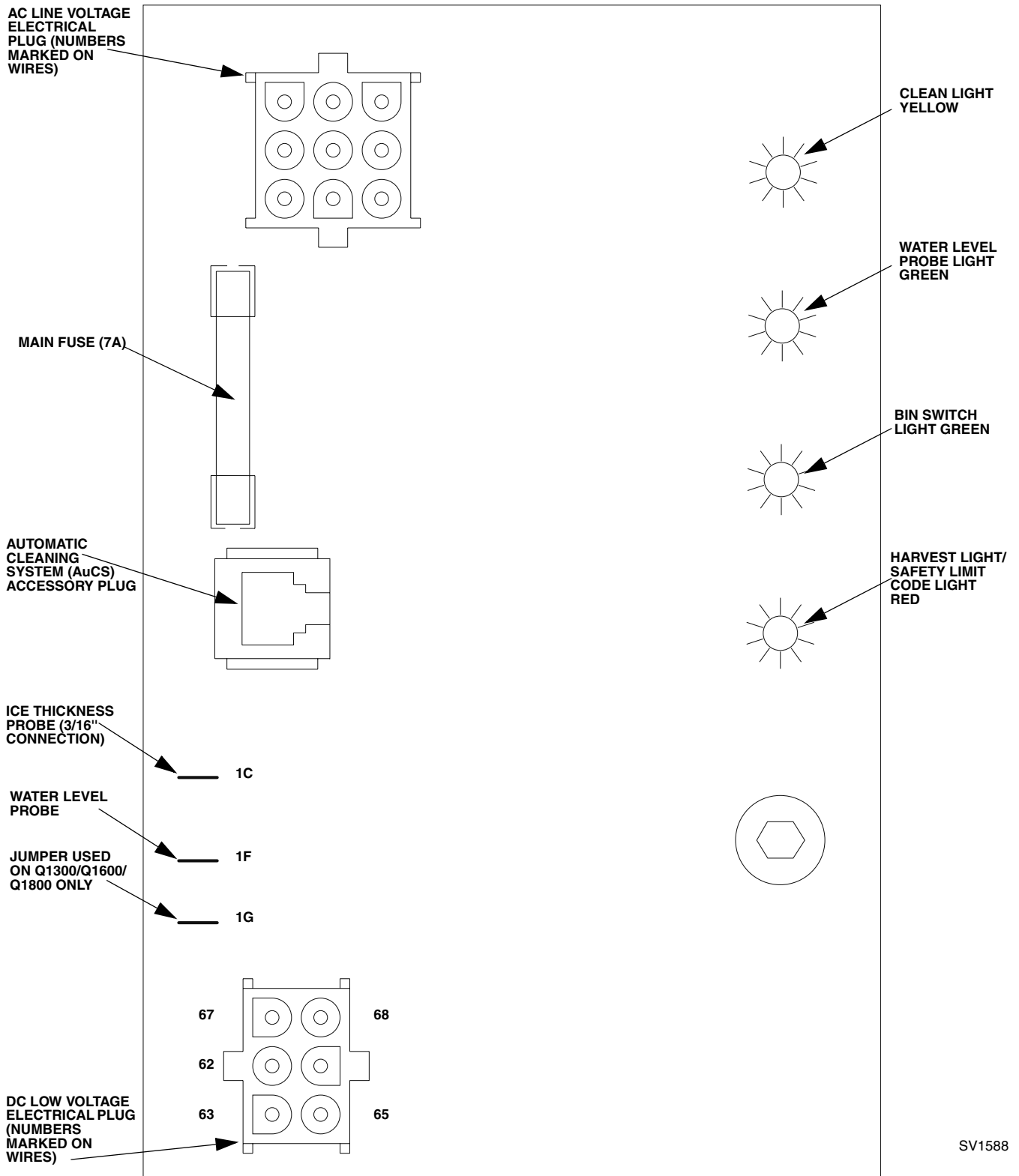

SV1588

Figure 6-19. Control Board

**General**

Q-Model control boards use a dual voltage transformer. This means only one control board is needed for both 115V and 208-230V use.

**Safety Limits**

In addition to standard safety controls, such as the high pressure cut-out, the control board has built-in safety limits.

These safety limits protect the ice machine from major component failures. For more information, see “Safety Limits” on **Page 7-13**.

**Inputs**

The control board, along with inputs, controls all electrical components, including the ice machine sequence of operation. Prior to diagnosing, you must understand how the inputs affect the control board operation.

Refer to specific component specifications (inputs), wiring diagrams and ice machine sequence of operation sections for details.

As an example, refer to “Ice Thickness Probe” on the next page for information relating to how the probe and control board function together.

This section will include items such as:

- How a harvest cycle is initiated
- How the harvest light functions with the probe
- Freeze time lock-in feature
- Maximum freeze time
- Diagnosing ice thickness control circuitry

## Ice Thickness Probe (Harvest Initiation)

### HOW THE PROBE WORKS

Manitowoc's electronic sensing circuit does not rely on refrigerant pressure, evaporator temperature, water levels or timers to produce consistent ice formation.

As ice forms on the evaporator, water (not ice) contacts the ice thickness probe. After the water completes this circuit across the probe continuously for 6-10 seconds, a harvest cycle is initiated.

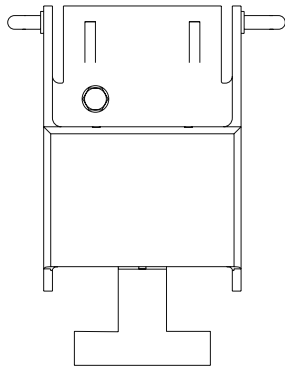

SV1730A

Figure 6-20. Ice Thickness Probe

### HARVEST/SAFETY LIMIT LIGHT

This light's primary function is to be on as water contacts the ice thickness probe during the freeze cycle, and remain on throughout the entire harvest cycle. The light will flicker as water splashes on the probes.

The light's secondary function is to continuously flash when the ice machine is shut off on a safety limit, and to indicate which safety limit shut off the ice machine.

### FREEZE TIME LOCK-IN FEATURE

The ice machine control system incorporates a freeze time lock-in feature. This prevents the ice machine from short cycling in and out of harvest.

The control board locks the ice machine in the freeze cycle for six minutes. If water contacts the ice thickness probe during these six minutes, the harvest light will come on (to indicate that water is in contact with the probe), but the ice machine will stay in the freeze cycle. After the six minutes are up, a harvest cycle is initiated. This is important to remember when performing diagnostic procedures on the ice thickness control circuitry.

To allow the service technician to initiate a harvest cycle without delay, this feature is not used on the first cycle after moving the toggle switch OFF and back to ICE.

### MAXIMUM FREEZE TIME

The control system includes a built-in safety which will automatically cycle the ice machine into harvest after 60 minutes in the freeze cycle.

### ICE THICKNESS CHECK

The ice thickness probe is factory-set to maintain the ice bridge thickness at 1/8" (3.2 mm).

NOTE: Make sure the water curtain is in place when performing this check. It prevents water from splashing out of the water trough.

1. Inspect the bridge connecting the cubes. It should be about 1/8" (3.2 mm) thick.
2. If adjustment is necessary, turn the ice thickness probe adjustment screw clockwise to increase bridge thickness, or counterclockwise to decrease bridge thickness.

NOTE: Turning the adjustment 1/3 of a turn will change the ice thickness about 1/16" (1.5 mm).

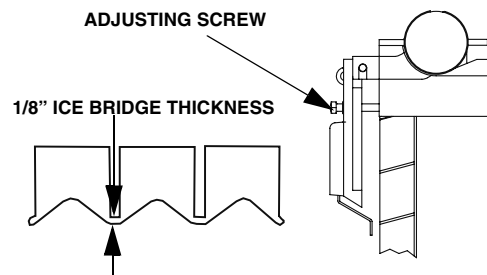

SV1208

Figure 6-21. Ice Thickness Check

Make sure the ice thickness probe wire and the bracket do not restrict movement of the probe.

### Ice Thickness Probe Cleaning

1. Mix a solution of Manitowoc ice machine cleaner and water (2 ounces of cleaner to 16 ounces of water) in a container.
2. Soak ice thickness probe in container of cleaner/water solution while disassembling and cleaning water circuit components (soak ice thickness probe for 10 minutes or longer).
3. Clean all ice thickness probe surfaces including all plastic parts (do not use abrasives). Verify the ice thickness probe cavity is clean. Thoroughly rinse ice thickness probe (including cavity) with clean water, then dry completely. **Incomplete rinsing and drying of the ice thickness probe can cause premature harvest.**
4. Reinstall ice thickness probe, then sanitize all ice machine and bin/dispenser interior surfaces.

**DIAGNOSING ICE THICKNESS CONTROL CIRCUITRY**

**Ice Machine Does Not Cycle Into Harvest When Water Contacts The Ice Thickness Control Probe**

**Step 1** Bypass the freeze time lock-in feature by moving the ICE/OFF/CLEAN switch to OFF and back to ICE. Wait until the water starts to flow over the evaporator.

**Step 2** Clip the jumper wire leads to the ice thickness probe and any cabinet ground.

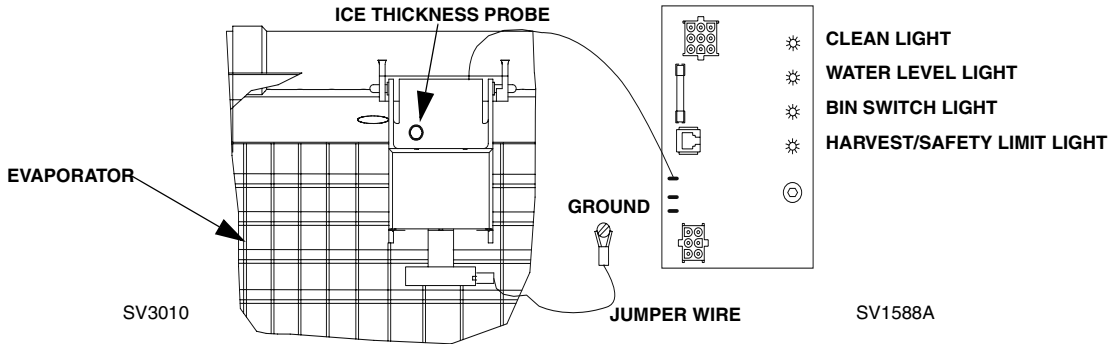

**Figure 6-22. Step 2**

| <b>Step 2 Jumper wire connected from probe to ground</b>                                       |  |
|--|--|
| <b>Monitoring of Harvest Light</b>   | <b>Correction</b>  |
| The harvest light comes on, and 6-10 seconds later, ice machine cycles from freeze to harvest. | The ice thickness control circuitry is functioning properly. Do not change any parts.  |
| The harvest light comes on but the ice machine stays in the freeze sequence.                   | The ice thickness control circuitry is functioning properly. The ice machine is in a six-minute freeze time lock-in. Verify step 1 of this procedure was followed correctly. |
| The harvest light does not come on.  | Proceed to Step 3, below.  |

**Step 3** Disconnect the ice thickness probe from the control board at terminal 1C. Clip the jumper wire leads to terminal 1C on the control board and any cabinet ground. Monitor the harvest light.

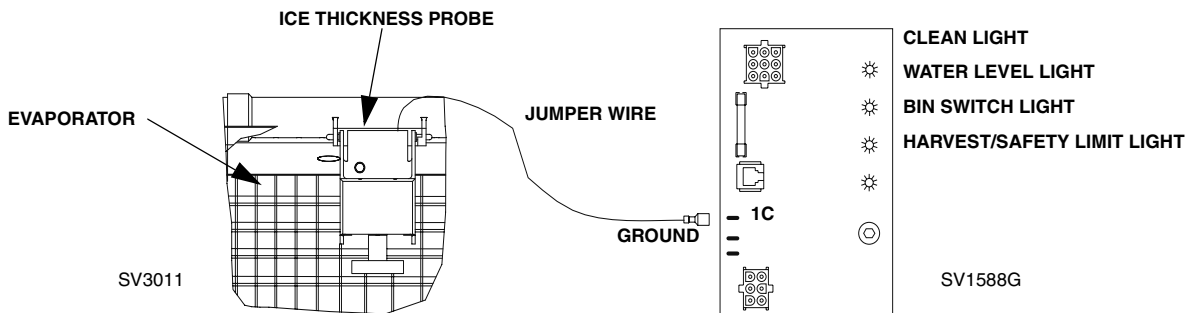

**Figure 6-23. Step 3**

| <b>Step 3 Jumper wire connected from control board terminal 1C to ground</b>                   |   |
|--|---|
| <b>Monitoring of Harvest Light</b>   | <b>Correction</b>   |
| The harvest light comes on, and 6-10 seconds later, ice machine cycles from freeze to harvest. | The ice thickness probe is causing the malfunction.   |
| The harvest light comes on but the ice machine stays in the freeze sequence.                   | The control circuitry is functioning properly. The ice machine is in a six-minute freeze time lock-in (verify step 1 of this procedure was followed correctly). |
| The harvest light does not come on.  | The control board is causing the malfunction.   |

**Ice Machine Cycles Into Harvest Before Water Contact With The Ice Thickness Probe**

**Step 1** Bypass the freeze time lock-in feature by moving the ICE/OFF/CLEAN switch to OFF and back to ICE. Wait until the water starts to flow over the evaporator, then monitor the harvest light.

**Step 2** Disconnect the ice thickness probe from the control board at terminal 1C.

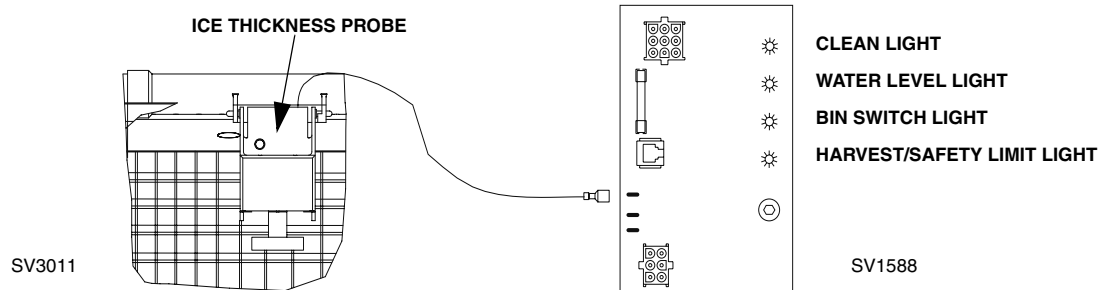

**Figure 6-24. Step 2**

| <b>Step 2 Disconnect probe from control board terminal 1C.</b>                                     |  |
|--|--|
| <b>Monitoring of Harvest Light</b>   | <b>Correction</b>  |
| The harvest light stays off and the ice machine remains in the freeze sequence.                    | The ice thickness probe is causing the malfunction. Verify that the Ice Thickness probe is adjusted correctly. |
| The harvest light comes on, and 6-10 seconds later, the ice machine cycles from freeze to harvest. | The control board is causing the malfunction.  |

### Water Level Control Circuitry

#### WATER LEVEL PROBE LIGHT

The water level probe circuit can be monitored by watching the water level light. The water level light is on when water contacts the probe, and off when no water is in contact with the probe. The water level light functions any time power is applied to the ice machine, regardless of toggle switch position.

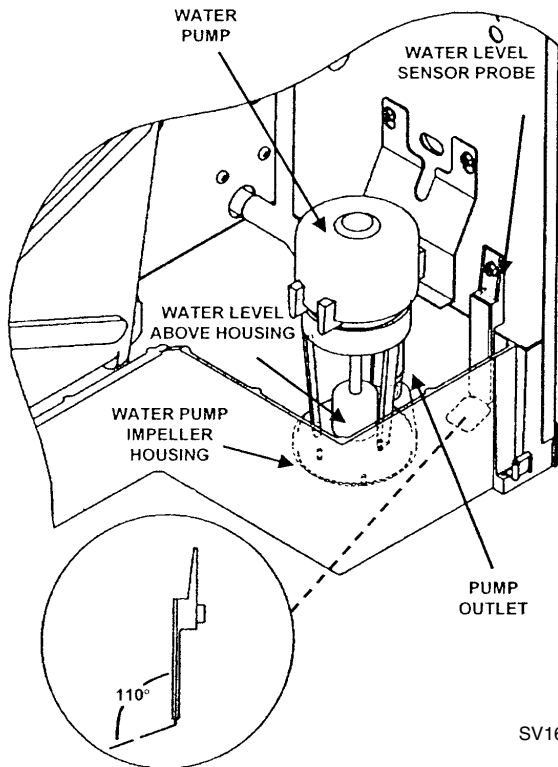

SV1616

**Figure 6-25. Freeze Cycle Water Level Setting**

During the freeze cycle, the water level probe is set to maintain the proper water level above the water pump housing. The water level is not adjustable. If the water level is incorrect, check the water level probe for damage (probe bent, etc.). Repair or replace the probe as necessary.

#### WATER INLET VALVE SAFETY SHUT-OFF

In the event of a water level probe failure, this feature limits the water inlet valve to a six-minute on time. Regardless of the water level probe input, the control board automatically shuts off the water inlet valve if it remains on for 6 continuous minutes. This is important to remember when performing diagnostic procedures on the water level control circuitry.

### FREEZE CYCLE CIRCUITRY

Manitowoc's electronic sensing circuit does not rely on float switches or timers to maintain consistent water level control. During the freeze cycle, the water inlet valve energizes (turns on) and de-energizes (turns off) in conjunction with the water level probe located in the water trough.

#### During the first 45 seconds of the Freeze Cycle:

- The water inlet valve is **on** when there is no water in contact with the water level probe.
- The water inlet valve turns **off** after water contacts the water level probe for 3 continuous seconds.
- The water inlet valve will cycle on and off as many times as needed to fill the water trough.

#### After 45 seconds into the Freeze Cycle:

The water inlet valve will cycle on, and then off one more time to refill the water trough. The water inlet valve is now off for the duration of the freeze sequence.

### HARVEST CYCLE CIRCUITRY

The water level probe does not control the water inlet valve during the harvest cycle. During the harvest cycle water purge, the water inlet valve energizes (turns on) and de-energizes (turns off) strictly by time. The harvest water purge adjustment dial may be set at 15, 30 or 45 seconds.

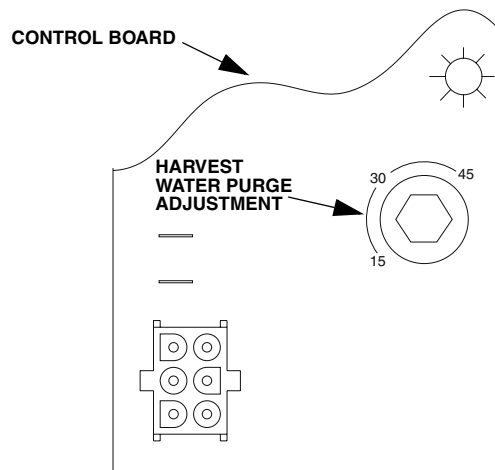

SV1617

**NOTE:** The water purge **must be at the factory setting** of 45 seconds for the water inlet valve to energize during the last 15 seconds of the Water Purge. If set at 15 or 30 seconds the water inlet valve will not energize during the harvest water purge.

**DIAGNOSING FREEZE CYCLE POTABLE WATER LEVEL CONTROL CIRCUITRY**

**Problem: Water Trough Overfilling During The Freeze Cycle**

**Step 1** Start a new freeze sequence by moving the ICE/OFF/CLEAN toggle switch to OFF, then back to ICE.

**Important**

This restart must be done prior to performing diagnostic procedures. This assures the ice machine is not in a freeze cycle water inlet valve safety shut-off mode. You must complete the entire diagnostic procedure within 6 minutes of starting.

**Step 2** Wait until the freeze cycle starts (approximately 45 seconds, the freeze cycle starts when the compressor energizes) then connect a jumper from the water level probe to any cabinet ground.

**Important**

For the test to work properly you must wait until the freeze cycle starts, prior to connecting the jumper wire. If you restart the test you must disconnect the jumper wire, restart the ice machine, (step 1) and then reinstall the jumper wire after the compressor starts.

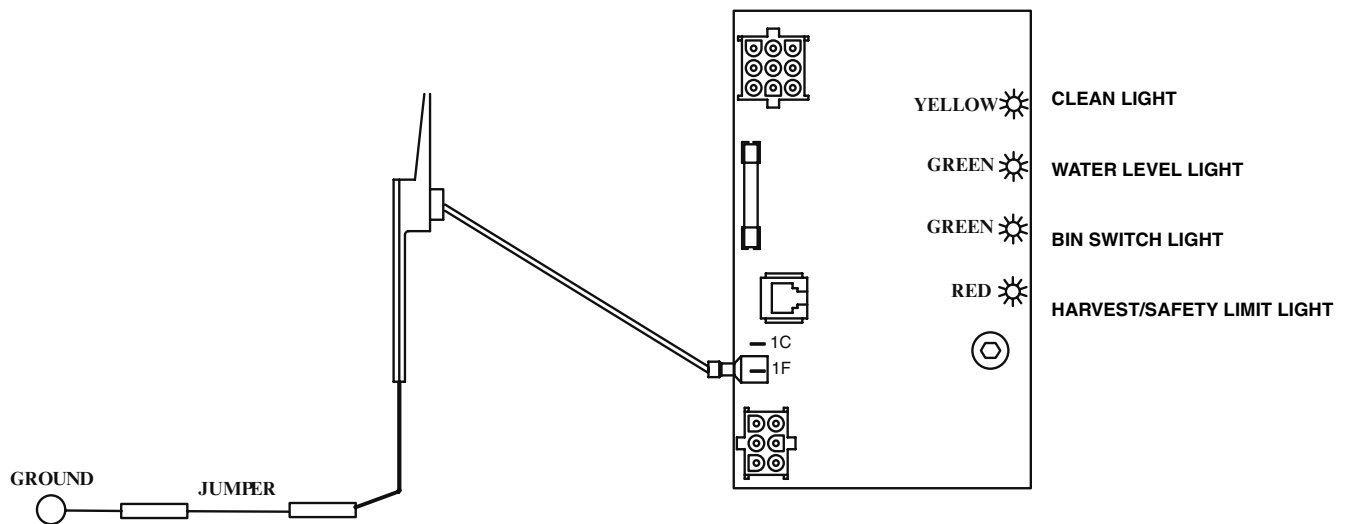

SV1621a

**Figure 6-26. Step 2**

| Step 2 Jumper wire connected from probe to ground |                           |   |  |
|---|---------------------------|---|--|
| Is water flowing into the water trough?           | The Water Level Light is: | The Water Inlet Valve Solenoid Coil is: | Cause  |
| no  | on                        | De-Energized                            | This is normal operation. Do not change any parts. |
| yes   | on                        | De-Energized                            | The water inlet valve is causing the problem.      |
| yes   | off                       | Energized                               | Proceed to step 3.                                 |

Continued on next page ...

**Problem: Water Trough Overfilling During The Freeze Cycle (continued)**

**Step 3** Allow ice machine to run. Disconnect the water level probe from control board terminal 1F, and connect a jumper wire from terminal 1F to any cabinet ground.

Remember if you are past 6 minutes from starting, the ice machine will go into a freeze cycle water inlet valve safety shut-off mode, and you will be unable to complete this test. If past 6 minutes you must restart this test by disconnecting the jumper wire, restarting the ice machine, (step 1) and then reinstalling the jumper wire to terminal 1F, after the compressor starts.

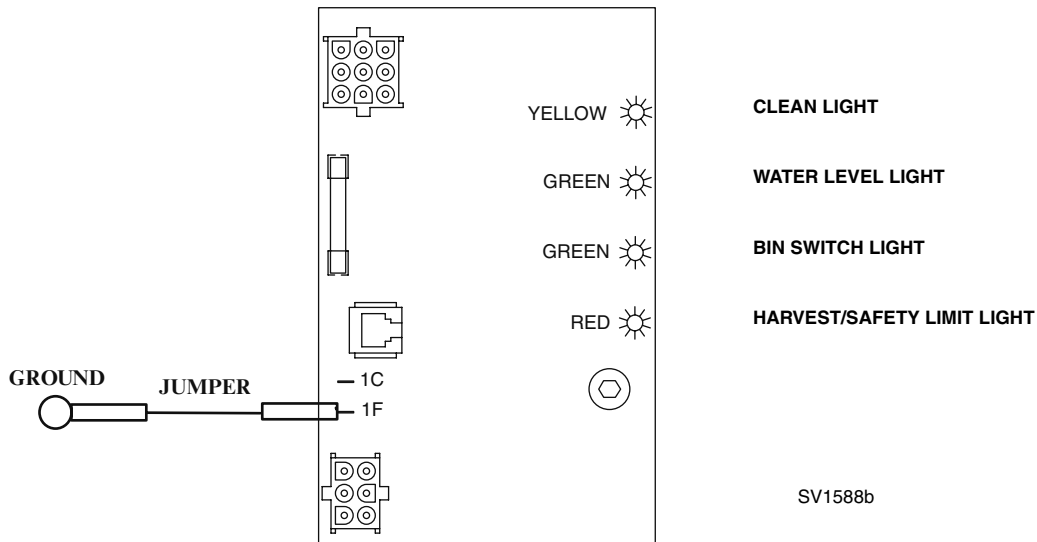

Figure 6-27. Step 3

| Step 3 Jumper wire connected from control board terminal 1F to ground |                           |   |   |
|---|---------------------------|---|---|
| Is water flowing into the water trough?                               | The Water Level Light is: | The Water Inlet Valve Solenoid Coil is: | Cause   |
| no  | on                        | De-Energized                            | The water level probe is causing the problem. Clean or replace the water level probe. |
| yes   | off                       | Energized                               | The control board is causing the problem.   |
| yes   | on                        | De-Energized                            | The water fill valve is causing the problem.  |



**Problem: Water Will Not Run Into The Sump Trough During The Freeze Cycle**

**Step 1** Verify water is supplied to the ice machine, and then start a new freeze sequence by moving the ICE/OFF/CLEAN toggle switch to OFF then back to ICE.

**Step 2** Wait until the freeze cycle starts (approximately 45 seconds, the freeze cycle starts when the compressor energizes), and then refer to chart.

**Important**

This restart must be done prior to performing diagnostic procedures. This assures the ice machine is not in a freeze cycle water inlet valve safety shut-off mode. You must complete the entire diagnostic procedure within 6 minutes of starting.

| Step 2 Checking for normal operation    |                           |   |   |
|---|---------------------------|---|---|
| Is water flowing into the water trough? | The Water Level Light is: | The Water Inlet Valve Solenoid Coil is: | Cause   |
| yes                                     | off                       | Energized                               | This is Normal Operation don't change any parts |
| no                                      | on or off                 | Energized Or De-Energized               | Proceed to step 3                               |

**Step 3** Leave the ice machine run, then disconnect the water level probe from control board terminal 1F.

**Important**

For the test to work properly you must wait until the freeze cycle starts, prior to disconnecting the water level probe. If you restart the test you must reconnect the water level probe, restart the ice machine, (step 1) and then disconnect the water level probe after the compressor starts.

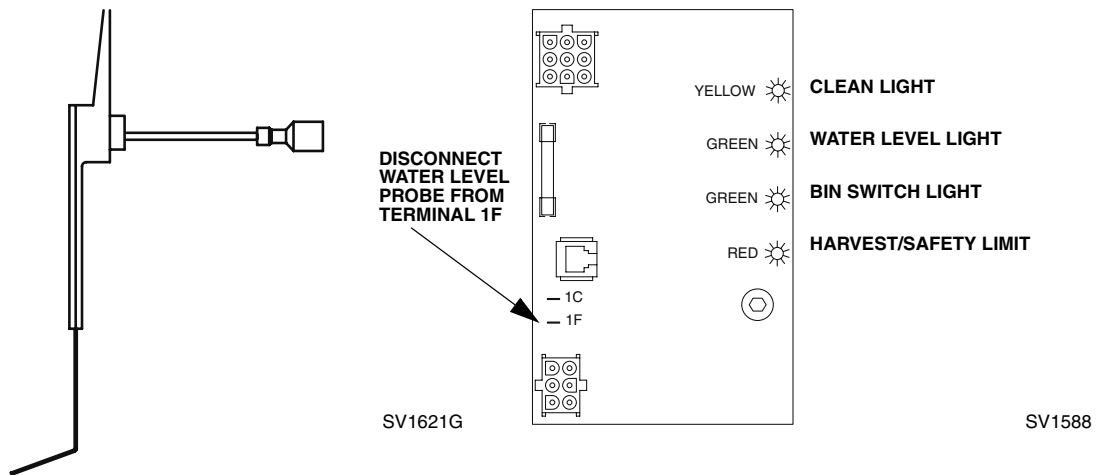

Figure 6-28. Step 3

| Step 3 Disconnect water level probe from control board terminal 1F |                           |   |   |
|--|---------------------------|---|---|
| Is water flowing into the water trough?                            | The Water Level Light is: | The Water Inlet Valve Solenoid Coil is: | Cause   |
| yes  | off                       | Energized                               | The water level probe is causing the problem. Clean or replace the water level probe. |
| no   | off                       | Energized                               | The water inlet valve is causing the problem.   |
| no   | on or off                 | De-Energized                            | The control board is causing the problem.   |

## Diagnosing An Ice Machine That Will Not Run

 **Warning**

High (line) voltage is applied to the control board (terminals #55 and #56) at all times. Removing control board fuse or moving the toggle switch to OFF will not remove the power supplied to the control board.

| Step | Check  | Notes   |
|------|--|---|
| 1    | Verify primary voltage supply to ice machine.          | Verify that the fuse or circuit breaker is closed.  |
| 2    | Verify the high-pressure cutout is closed.             | The H.P.C.O. is closed if primary power voltage is present at terminals #55 and #56 on the control board.       |
| 3    | Verify control board fuse is OK.                       | If the bin switch light functions, the fuse is OK.  |
| 4    | Verify the bin switch functions properly.              | A defective bin switch can falsely indicate a full bin of ice.  |
| 5    | Verify ICE/OFF/CLEAN toggle switch functions properly. | A defective toggle switch may keep the ice machine in the OFF mode.   |
| 6    | Verify low DC voltage is properly grounded.            | Loose DC wire connections may intermittently stop the ice machine.  |
| 7    | Replace the control board.                             | Be sure Steps 1-6 were followed thoroughly. Intermittent problems are not usually related to the control board. |

NOTE: Refer to wiring diagram on **Page 6-55** for component and sequence identification.

**Q0420/Q0450/Q0600/Q0800/Q1000 - SELF CONTAINED - 1 PHASE WITH TERMINAL BOARD**

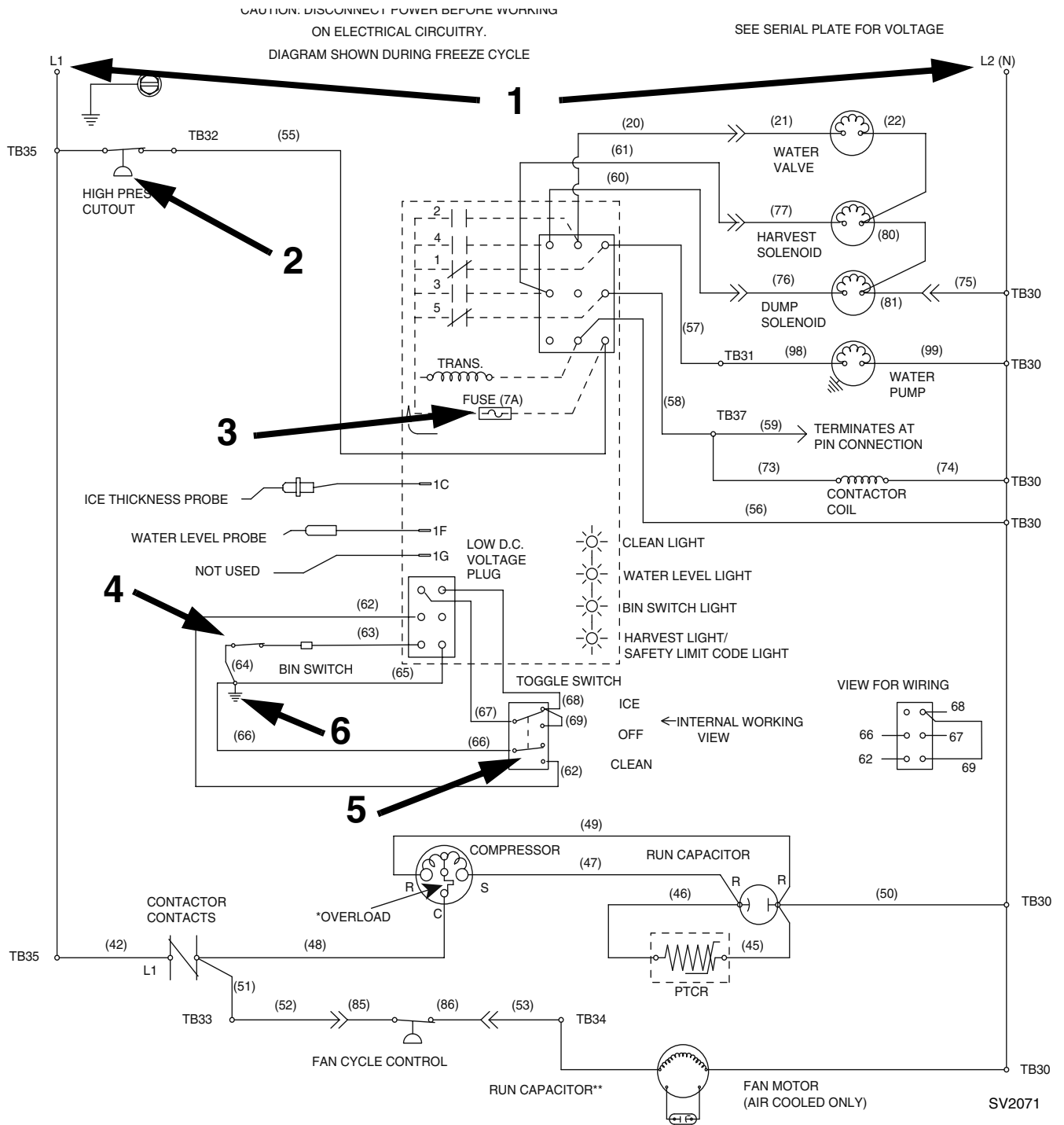

THIS PAGE INTENTIONALLY LEFT BLANK

# Section 7 Refrigeration System

## Sequence of Operation

### SELF-CONTAINED AIR OR WATER -COOLED MODELS

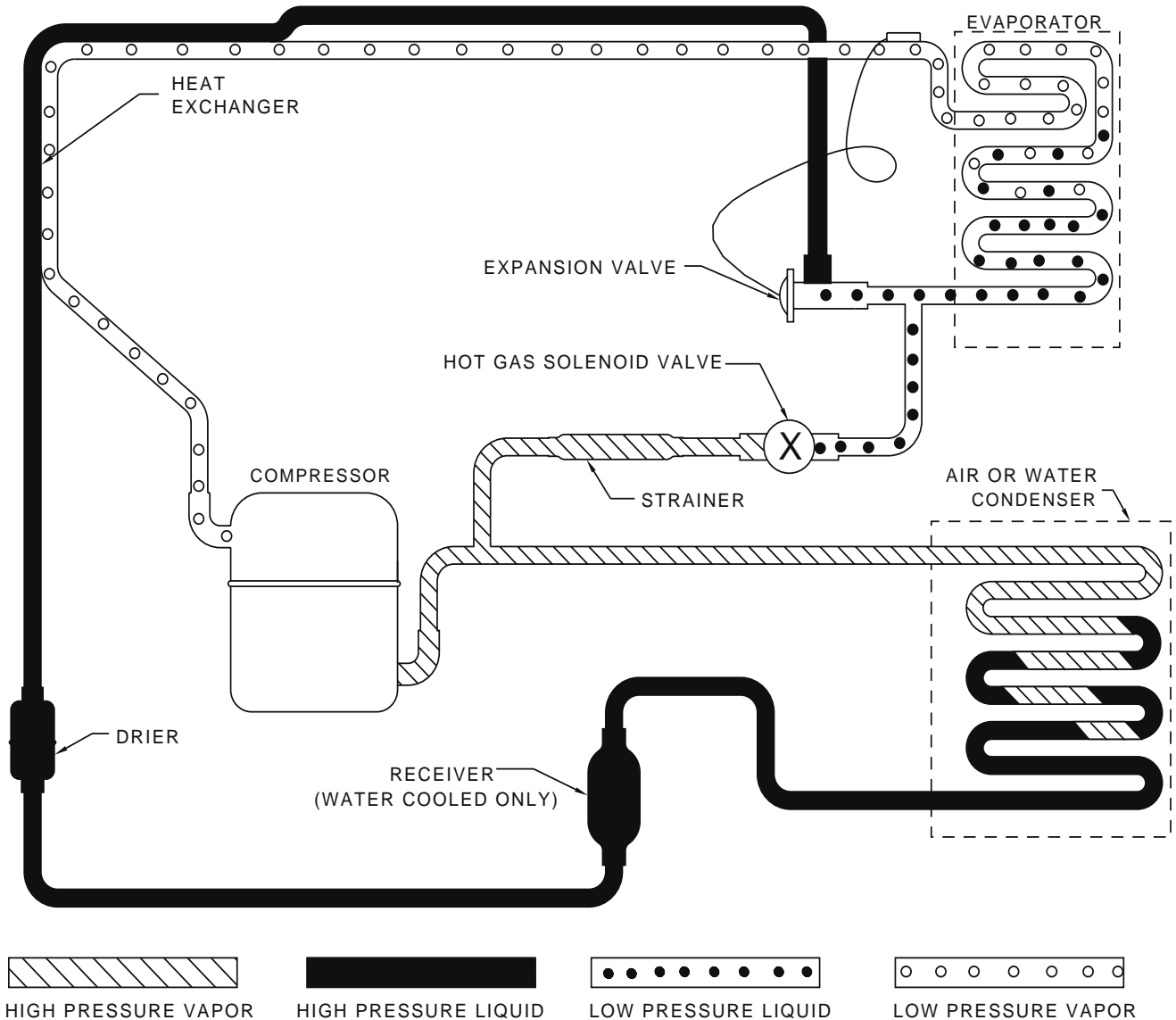

SV1569

**Figure 7-1. Self-Contained Prechill and Freeze Cycle  
(Models Q200/Q280/Q320/Q370/Q420/Q450/Q600/Q800/Q1000)**

#### Prechill Refrigeration Sequence

No water flows over the evaporator during the prechill. The refrigerant absorbs heat (picked up during the harvest cycle) from the evaporator. The suction pressure decreases during the prechill.

#### Freeze Cycle Refrigeration Sequence

The refrigerant absorbs heat from water running over the evaporator surface. The suction pressure gradually drops as ice forms.

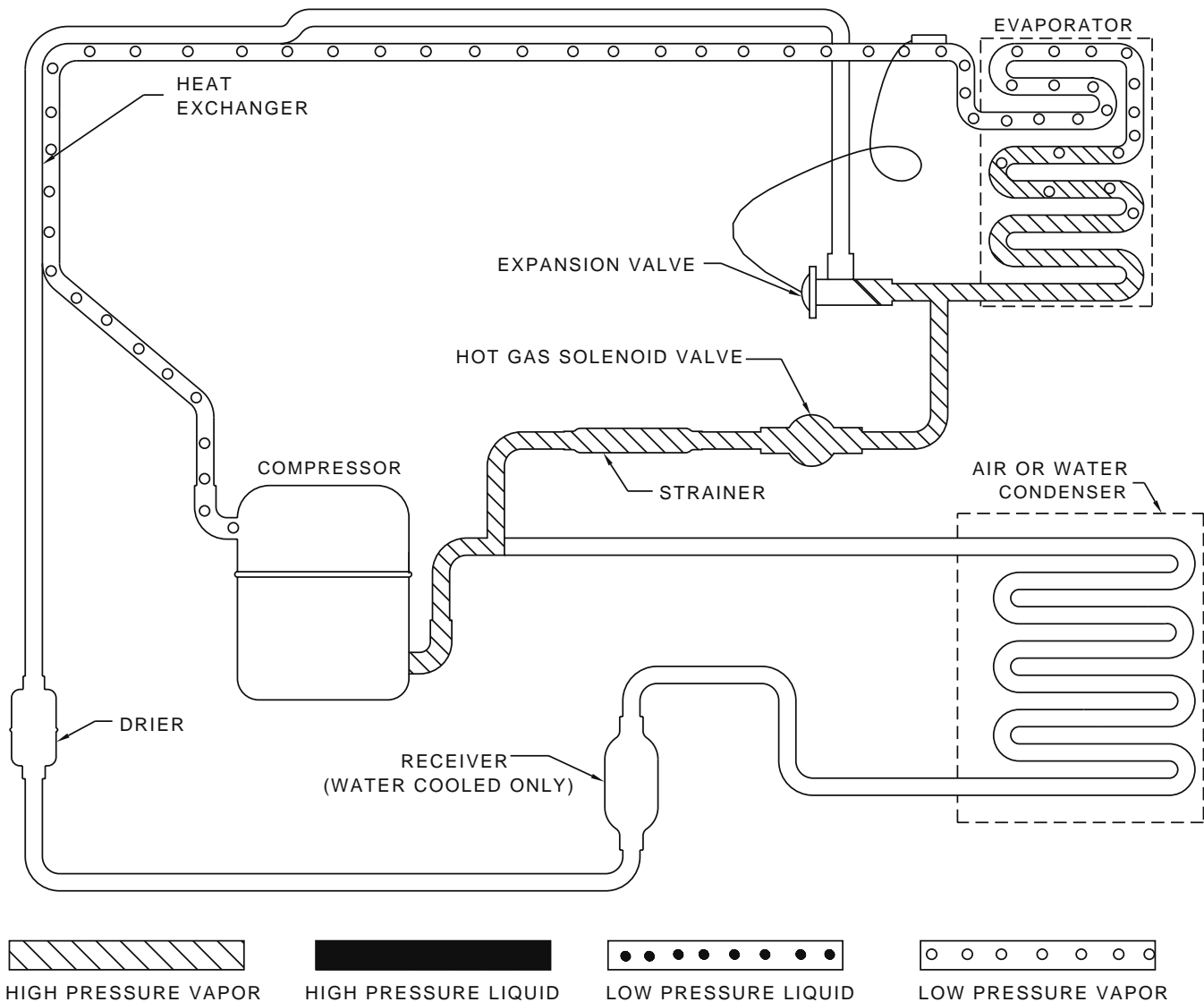

SV1570

**Figure 7-2. Self-Contained Harvest Cycle (Models Q200/Q280/Q320/Q370/Q420/Q450/Q600/Q800/Q1000)**

**Harvest Cycle Refrigeration Sequence**

Hot gas flows through the energized hot gas valve, heating the evaporator. The hot gas valve is sized to allow the proper amount of refrigerant into the evaporator. This specific sizing (along with the proper system refrigerant charge) assures proper heat transfer, without the refrigerant condensing and slugging the compressor.

REMOTE MODELS

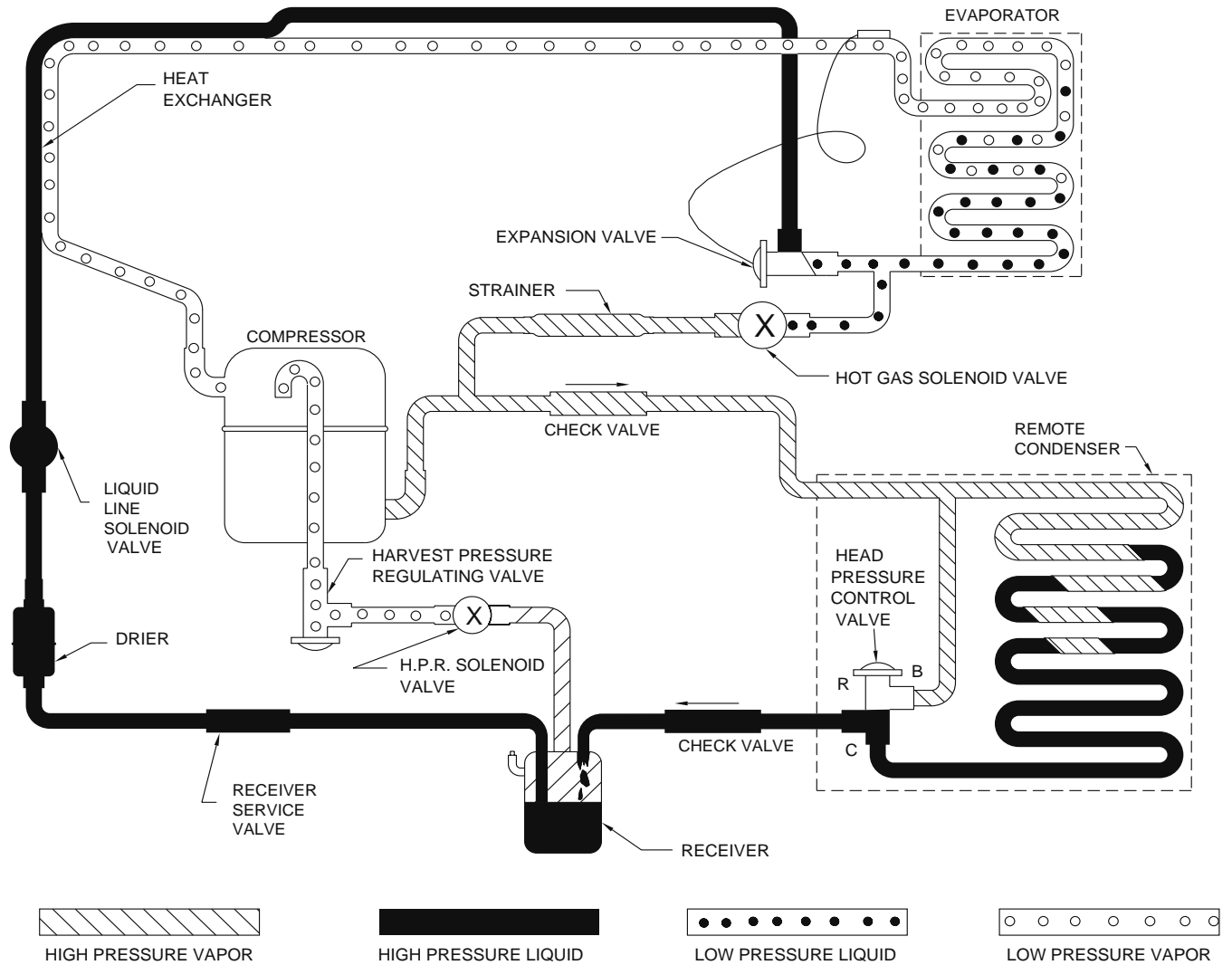

SV1566

**Figure 7-3. Remote Pre-Chill and Freeze Cycle (Models Q450/Q600/Q800/Q1000)**

**Prechill Refrigeration Sequence**

No water flows over the evaporator during the prechill. The refrigerant absorbs heat (picked up during the harvest cycle) from the evaporators. The suction pressure decreases during the prechill.

**Freeze Cycle Refrigeration Sequence**

The refrigerant absorbs heat from the water running over the evaporator surface. The suction pressure gradually drops as ice forms.

The headmaster control valve maintains discharge pressure in ambient temperatures below 70°F. (See "Headmaster Control Valve" on Page 7-30.)

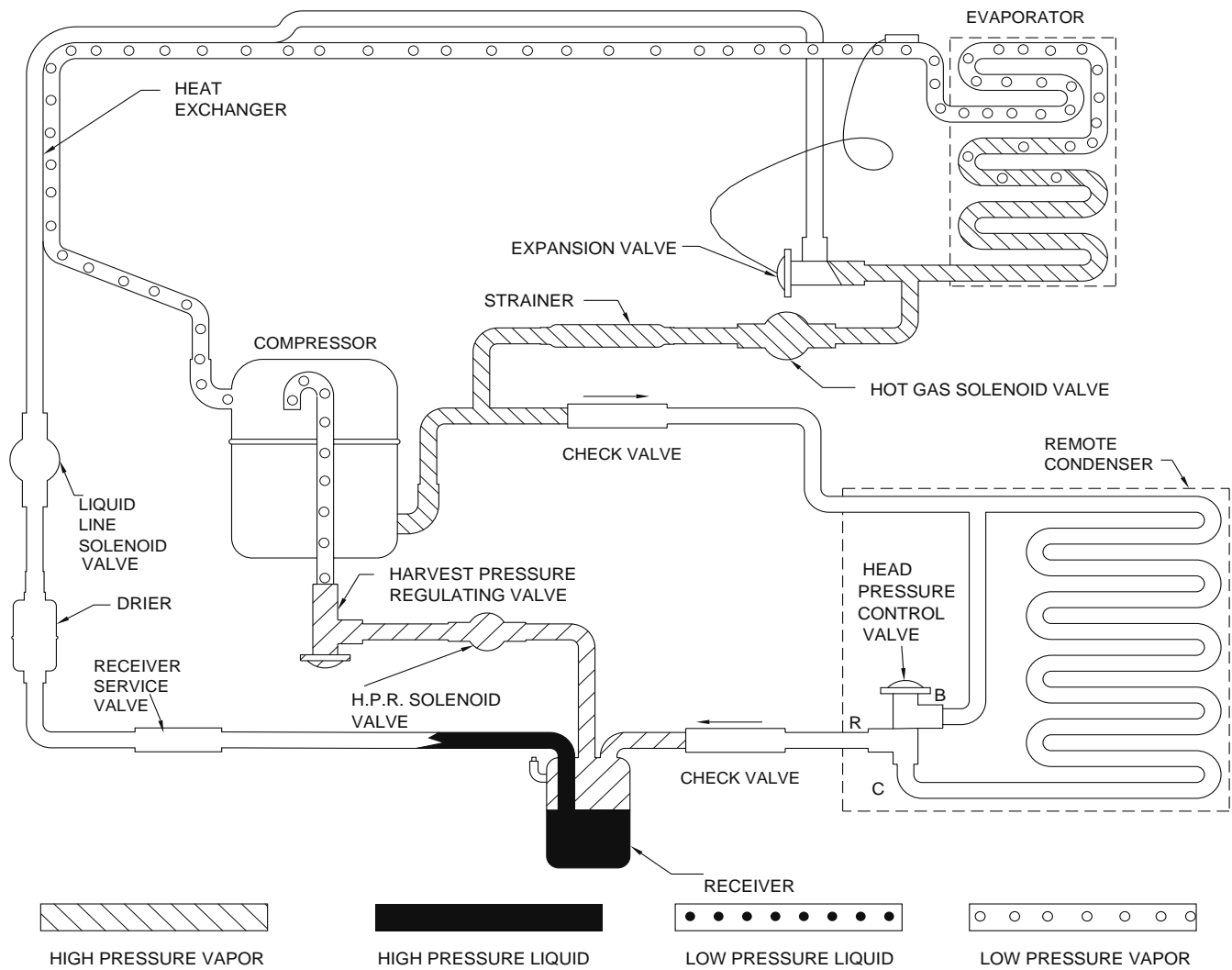

SV1567

**Figure 7-4. Remote Harvest Cycle (Models Q450/Q600/Q800/Q1000)**

**Harvest Cycle Refrigeration Sequence**

Hot gas flows through the energized hot gas valve, heating the evaporator. The hot gas valve is sized to allow the proper amount of hot gas into the evaporator. This specific hot gas valve sizing, along with the harvest pressure regulating (H.P.R.) system, assures proper heat transfer, without the hot gas condensing to liquid and slugging the compressor.

The harvest pressure regulating (H.P.R.) valve helps maintain the suction pressure during the harvest cycle. (See "H.P.R. System" on **Page 7-27.**)



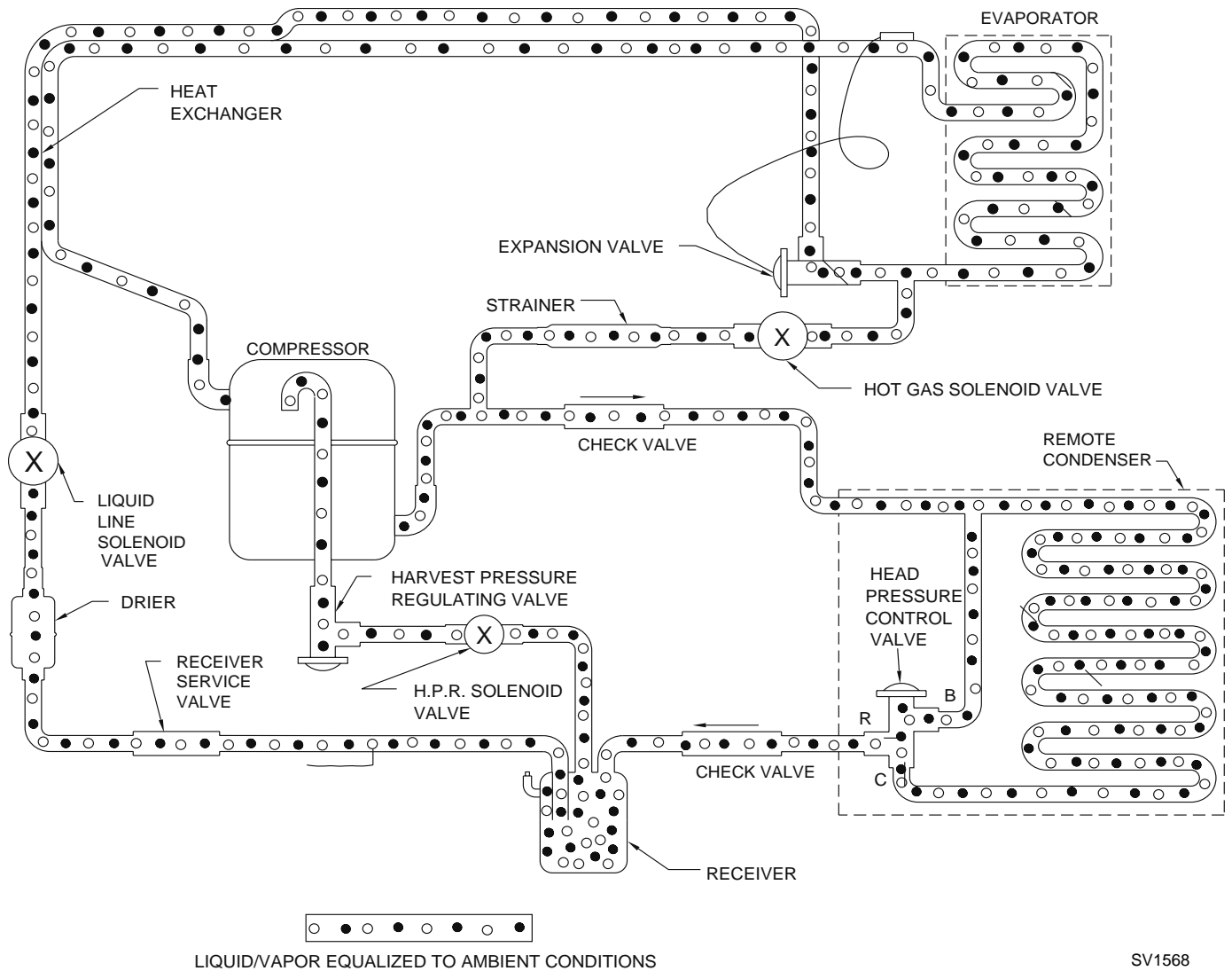

Figure 7-5. Remote Automatic Shut-Off (Models Q450/Q600/Q800/Q1000)

**Automatic Shut-Off**

The compressor and liquid line solenoid valve are de-energized simultaneously when the contactor contacts open.

During the off cycle, the check valve prevents refrigerant from migrating back into the high side, and the liquid line solenoid prevents refrigerant from migrating back into the low side. This protects the compressor from refrigerant migration during the off cycle, preventing refrigerant slugging upon start-up.

Q1300/Q1600/Q1800 REFRIGERATION TUBING SCHEMATICS

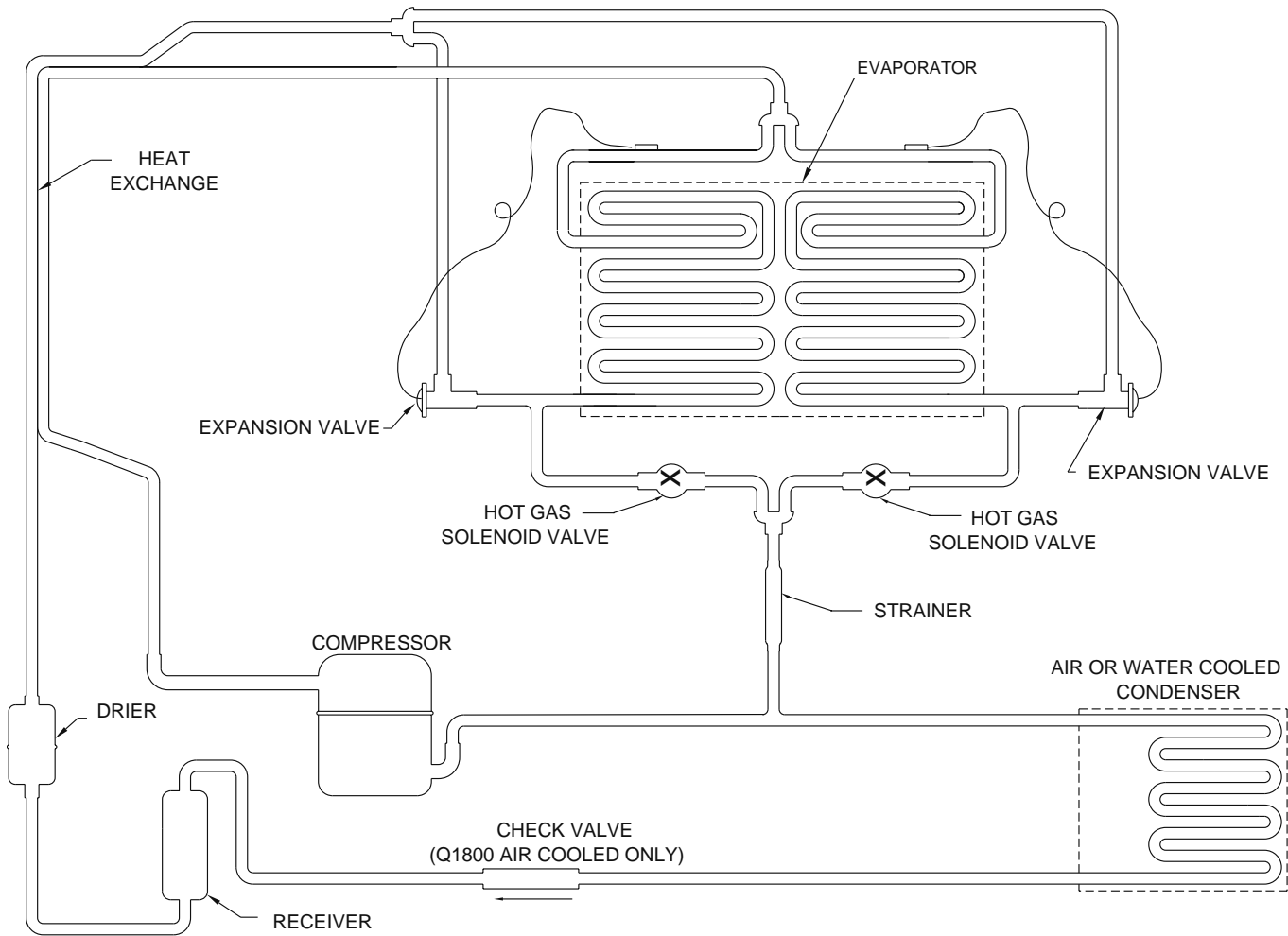

SV1512

**Figure 7-6. Q1300/Q1600/Q1800 Self-Contained Air- or Water-Cooled Models**

NOTE: The refrigeration sequence for self-contained dual expansion valve ice machines is identical to self-contained single expansion valve ice machines. See **Pages 7-1 and 7-2** for sequence of operation.

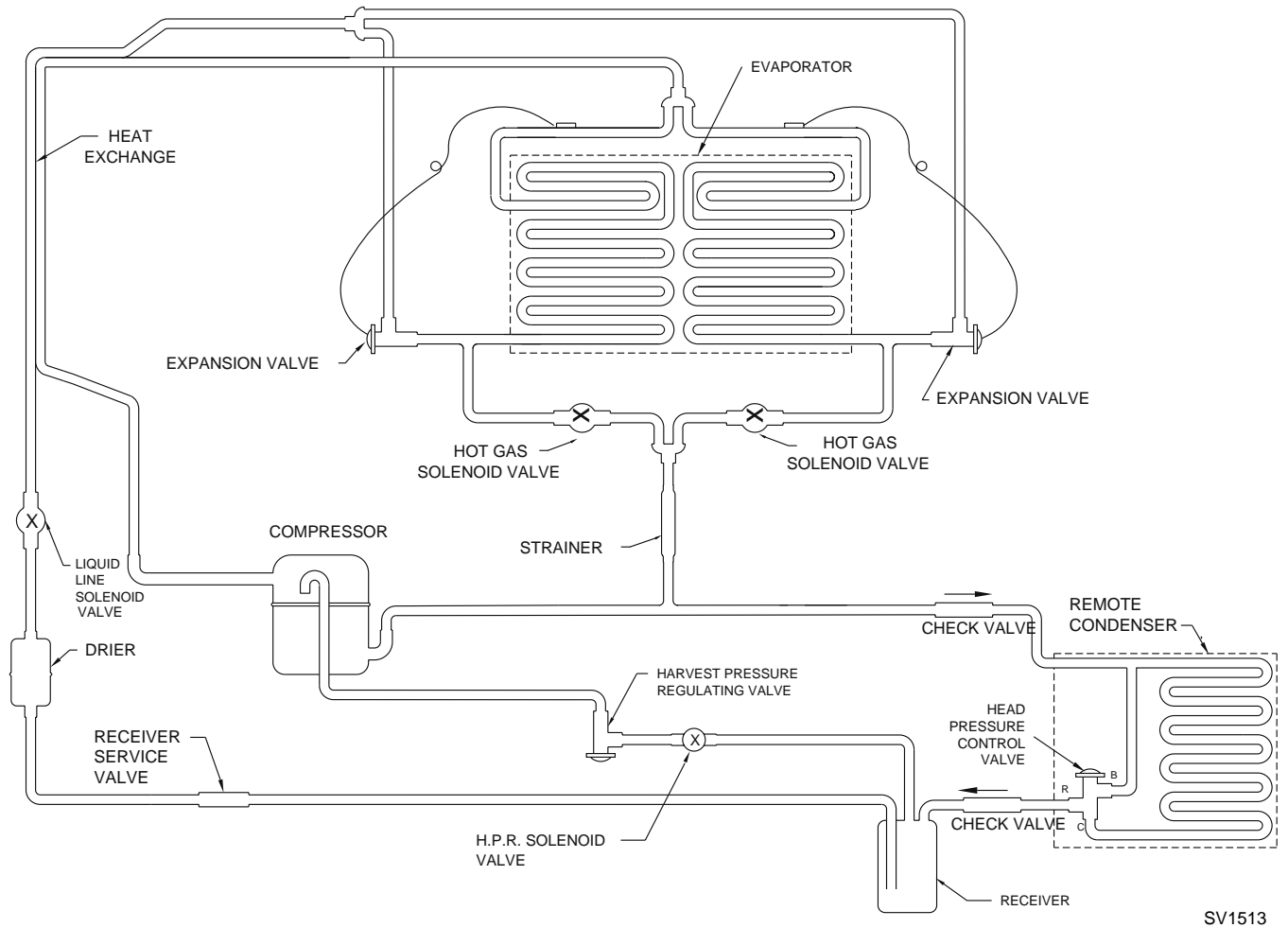

**Figure 7-7. Q1300/Q1600/Q1800 Remote Models**

NOTE: The refrigeration sequence for remote dual expansion valve ice machines is identical to remote single expansion valve ice machines. See **Pages 7-3, 7-4 and 7-5** for sequence of operation.

## Operational Analysis (Diagnostics)

### GENERAL

When analyzing the refrigeration system, it is important to understand that different refrigeration component malfunctions may cause very similar symptoms.

Also, many external factors can make good refrigeration components appear bad. These factors can include improper installation, or water system malfunctions such as hot incoming water supply or water loss.

The following two examples illustrate how similar symptoms can result in a misdiagnosis.

1. An expansion valve bulb that is not securely fastened to the suction line and/or not insulated will cause a good expansion valve to flood. If a service technician fails to check for proper expansion valve bulb mounting, he may replace the expansion valve in error.

The ice machine now functions normally. The technician erroneously thinks that the problem was properly diagnosed and corrected by replacing the expansion valve. Actually, the problem (loose bulb) was corrected when the technician properly mounted the bulb of the replacement expansion valve.

The service technician's failure to check the expansion valve bulb for proper mounting (an external check) resulted in a misdiagnosis and the needless replacement of a good expansion valve.

2. An ice machine that is low on charge may cause a good expansion valve to starve. If a service technician fails to verify the system charge, he may replace the expansion valve in error.

During the replacement procedure, recovery, evacuation and recharging are performed correctly. The ice machine now functions normally. The technician erroneously thinks that the problem was properly diagnosed and corrected by replacing the expansion valve.

The service technician's failure to check the ice machine for a low charge condition resulted in a misdiagnosis and the needless replacement of a good expansion valve.

When analyzing the refrigeration system, use the Refrigeration System Operational Analysis Table. This table, along with detailed checklists and references, will help prevent replacing good refrigeration components due to external problems.

**BEFORE BEGINNING SERVICE**

Ice machines may experience operational problems only during certain times of the day or night. A machine may function properly while it is being serviced, but malfunctions later. Information provided by the user can help the technician start in the right direction, and may be a determining factor in the final diagnosis.

Ask these questions before beginning service:

- When does the ice machine malfunction? (night, day, all the time, only during the freeze cycle, etc.)
- When do you notice low ice production? (one day a week, every day, on weekends, etc.)
- Can you describe exactly what the ice machine seems to be doing?
- Has anyone been working on the ice machine?
- Is anything (such as boxes) usually stored near or on the ice machine which could obstruct airflow around the machine?
- During “store shutdown,” is the circuit breaker, water supply or air temperature altered?
- Is there any reason why incoming water pressure might rise or drop substantially?

**ICE PRODUCTION CHECK**

The amount of ice a machine produces directly relates to the operating water and air temperatures. This means an ice machine in a 70°F (21.2°C) room with 50°F (10.0°C) water produces more ice than the same model ice machine in a 90°F (32.2°C) room with 70°F (21.2°C) water.

1. Determine the ice machine operating conditions:
  - Air temp. entering condenser: \_\_\_\_\_ °
  - Air temp. around ice machine: \_\_\_\_\_ °
  - Water temp. entering sump trough: \_\_\_\_\_ °

2. Refer to the appropriate 24 Hour Ice Production Chart. (These charts begin on **Page 7-33.**) Use the operating conditions determined in Step 1 to find published 24 hour ice production: \_\_\_\_\_
3. Perform an actual ice production check. Use the formula below.

|    |  |   |   |   |  |
|----|--|---|---|---|--|
| 1. | $\frac{\text{Freeze Time}}{1440}$                            | + | $\frac{\text{Harvest Time}}{\text{Total Cycle Time}}$ | = | $\text{Cycles Per Day}$                |
| 2. | $\frac{\text{Minutes in 24 Hours}}{\text{Total Cycle Time}}$ | ÷ | $\text{Cycles Per Day}$                               | = | $\text{Actual 24 Hour Ice Production}$ |
| 3. | $\frac{\text{Weight of One Harvest}}{\text{Cycles Per Day}}$ | x | $\text{Cycles Per Day}$                               | = | $\text{Actual 24 Hour Ice Production}$ |

**Important**

**Times are in minutes.**  
 Example: 1 min., 15 sec. converts to 1.25 min.  
 (15 seconds ÷ 60 seconds = .25 minutes)

**Weights are in pounds.**  
 Example: 2 lb., 6 oz. converts to 2.375 lb.  
 (6 oz. ÷ 16 oz. = .375 lb.)

**Weighing the ice is the only 100% accurate check.** However, if the ice pattern is normal and the 1/8" thickness is maintained, the ice slab weights listed with the 24 Hour Ice Production Charts may be used.

4. Compare the results of step 3 with step 2. Ice production is normal when these numbers match closely. If they match closely, determine if:
  - another ice machine is required.
  - more storage capacity is required.
  - relocating the existing equipment to lower the load conditions is required.

Contact the local Manitowoc distributor for information on available options and accessories.

**INSTALLATION/VISUAL INSPECTION CHECKLIST**

| Possible Problem  | Corrective Action  |
|---|--|
| Ice machine is not level  | Level the ice machine                                    |
| Improper clearance around top, sides and/or back of ice machine | Reinstall according to the Installation Manual           |
| Air-cooled condenser filter is dirty                            | Clean the condenser filter and/or condenser              |
| Ice machine is not on an independent electrical circuit         | Reinstall according to the Installation Manual           |
| Water filtration is plugged (if used)                           | Install a new water filter                               |
| Water drains are not run separately and/or are not vented       | Run and vent drains according to the Installation Manual |
| Remote condenser line set is improperly installed               | Reinstall according to the Installation Manual           |

**WATER SYSTEM CHECKLIST**

A water-related problem often causes the same symptoms as a refrigeration system component malfunction.

Example: A water dump valve leaking during the freeze cycle, a system low on charge, and a starving TXV have similar symptoms.

Water system problems must be identified and eliminated prior to replacing refrigeration components.

| Possible Problem   | Corrective Action  |
|--|--|
| Water area (evaporator) is dirty   | Clean as needed  |
| Water inlet pressure not between 20 and 80 psi                                       | Install a water regulator valve or increase the water pressure             |
| Incoming water temperature is not between 35°F (1.7°C) and 90°F (32.2°C).            | If too hot, check the hot water line check valves in other store equipment |
| Water filtration is plugged (if used)  | Install a new water filter   |
| Water dump valve leaking during the freeze cycle                                     | Clean/replace dump valve as needed   |
| Vent tube is not installed on water outlet drain                                     | See Installation Instructions  |
| Hoses, fittings, etc., are leaking water   | Repair/replace as needed   |
| Water fill valve is stuck open   | Clean/replace as needed  |
| Water is spraying out of the sump trough area  | Stop the water spray   |
| Uneven water flow across the evaporator  | Clean the ice machine  |
| Water is freezing behind the evaporator  | Correct the water flow   |
| Plastic extrusions and gaskets are not secured to the evaporator                     | Remount/replace as needed  |
| Water does not flow over the evaporator (not trickle) immediately after the prechill | Clean/replace water level probe as needed                                  |

### ICE FORMATION PATTERN

Evaporator ice formation pattern analysis is helpful in ice machine diagnostics.

Analyzing the ice formation pattern alone cannot diagnose an ice machine malfunction. However, when this analysis is used along with Manitowoc's Refrigeration System Operational Analysis Table, it can help diagnose an ice machine malfunction.

Improper ice formation can be caused by any number of problems.

Example: An ice formation that is "extremely thin on top" could be caused by a hot water supply, a dump valve leaking water, a faulty water fill valve, a low refrigerant charge, etc.

#### Important

Keep the water curtain in place while checking the ice formation pattern to ensure no water is lost.

#### 1. Normal Ice Formation

Ice forms across the entire evaporator surface.

At the beginning of the freeze cycle, it may appear that more ice is forming on the bottom of the evaporator than on the top. At the end of the freeze cycle, ice formation on the top will be close to, or just a bit thinner than, ice formation on the bottom. The dimples in the cubes at the top of the evaporator may be more pronounced than those on the bottom. This is normal.

The ice thickness probe must be set to maintain the ice bridge thickness at approximately 1/8". If ice forms uniformly across the evaporator surface, but does not reach 1/8" in the proper amount of time, this is still considered normal.

#### 2. Extremely Thin at Evaporator Outlet

There is no ice, or a considerable lack of ice formation on the top of the evaporator (tubing outlet).

Examples: No ice at all on the top of the evaporator, but ice forms on the bottom half of the evaporator. Or, the ice at the top of the evaporator reaches 1/8" to initiate a harvest, but the bottom of the evaporator already has 1/2" to 1" of ice formation.

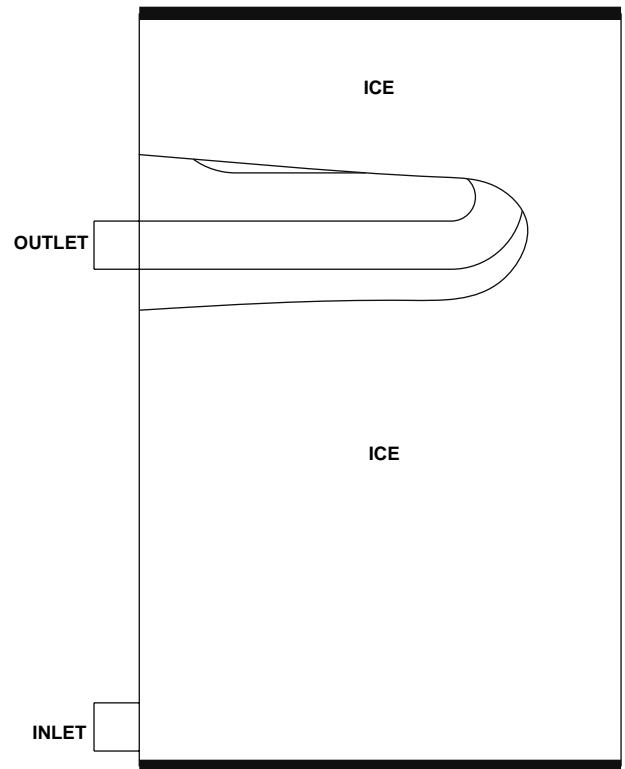

SV1576

Figure 7-8. Extremely Thin Ice Formation at Evaporator Outlet

**3. Extremely Thin at Evaporator Inlet**

There is no ice, or a considerable lack of ice formation on the bottom of the evaporator (tubing inlet). Examples: The ice at the top of the evaporator reaches 1/8" to initiate a harvest, but there is no ice formation at all on the bottom of the evaporator.

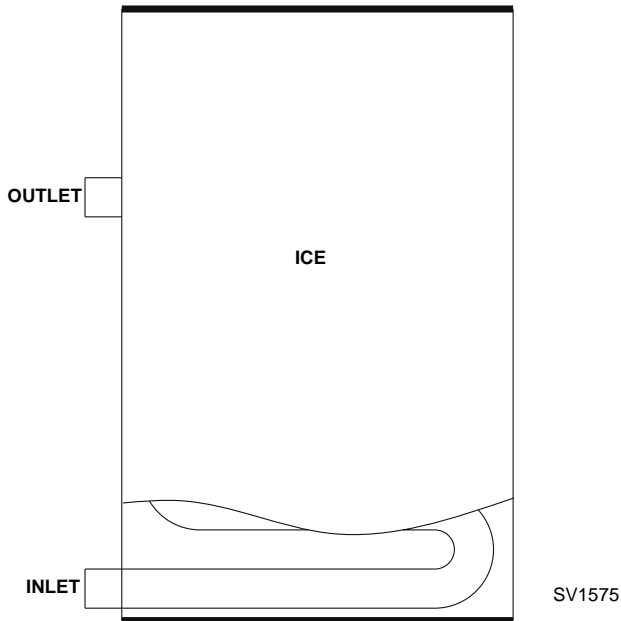

**Figure 7-9. Extremely Thin Ice Formation at Evaporator Inlet**

**4. Spotty Ice Formation**

There are small sections on the evaporator where there is no ice formation. This could be a single corner, or a single spot in the middle of the evaporator. This is generally caused by loss of heat transfer from the tubing on the back side of the evaporator.

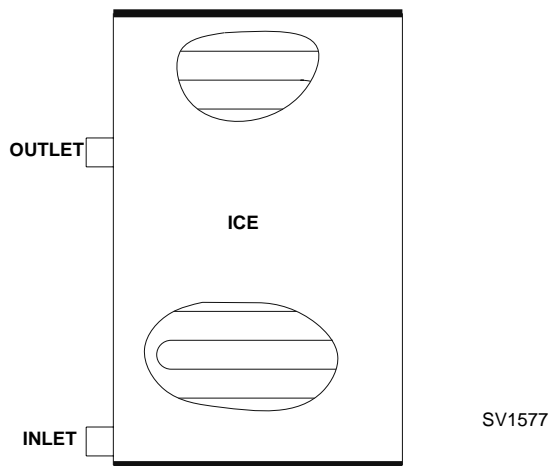

**Figure 7-10. Spotty Ice Formation**

**5. No Ice Formation**

The ice machine operates for an extended period, but there is no ice formation at all on the evaporator.

**Important**

The Q1300 Q1600 and Q1800 model machines have left and right expansion valves and separate evaporator circuits. These circuits operate independently from each other. Therefore, one may operate properly while the other is malfunctioning.

Example: If the left expansion valve is starving, it may not affect the ice formation pattern on the entire right side of the evaporator.

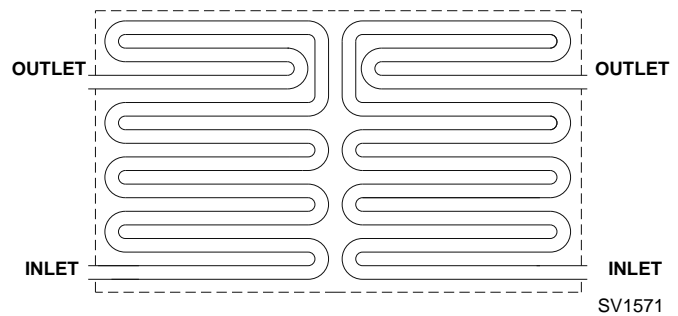

**Figure 7-11. Q1300/Q1600/Q1800 Evaporator Tubing**



**SAFETY LIMITS****General**

In addition to standard safety controls, such as high pressure cut-out, the control board has two built in safety limit controls which protect the ice machine from major component failures. There are two control boards with different safety limit sequences. Original production control boards have a black micro-processor. Current production and replacement control boards have an orange label on the control board microprocessor.

**Safety Limit #1:** If the freeze time reaches 60 minutes, the control board automatically initiates a harvest cycle.

Control Board with black microprocessor

If 3 consecutive 60-minute freeze cycles occur, the ice machine stops.

Control Board with orange label on microprocessor.

If 6 consecutive 60-minute freeze cycles occur, the ice machine stops.

**Safety Limit #2:** If the harvest time reaches 3.5 minutes, the control board automatically returns the ice machine to the freeze cycle.

Control Board with black microprocessor

If three consecutive 3.5 minute harvest cycles occur, the ice machine stops.

Control Board with orange label on microprocessor.

If 500 consecutive 3.5 minute harvest cycles occur, the ice machine stops.

**Safety Limit Indication****Control Board with Black Microprocessor**

When a safety limit condition is exceeded for 3 consecutive cycles the ice machine stops and the harvest light on the control board continually flashes on and off. Use the following procedures to determine which safety limit has stopped the ice machine.

1. Move the toggle switch to OFF.
2. Move the toggle switch back to ICE.
3. Watch the harvest light. It will flash one or two times, corresponding to safety limits 1 and 2, to indicate which safety limit stopped the ice machine.

After safety limit indication, the ice machine will restart and run until a safety limit is exceeded again.

**Control Board with Orange Label**

When a safety limit condition is exceeded for 3 consecutive cycles the control board enters the limit into memory and the ice machine continues to run. Use the following procedures to determine if the control board contains a safety limit indication.

1. Move the toggle switch to OFF.
2. Move the toggle switch back to ICE.
3. Watch the harvest light. If a safety limit has been recorded, the harvest light will flash one or two times, corresponding to safety limit 1 or 2.

When a safety limit condition is exceeded (6 consecutive cycles for Safety Limit #1 or 500 cycles for Safety Limit #2) the ice machine stops and the harvest light on the control board continually flashes on and off. Use the following procedures to determine which safety limit has stopped the machine.

1. Move the toggle switch to OFF.
2. Move the toggle switch back to ICE.
3. Watch the harvest light. It will flash one or two times, corresponding to safety limit 1 or 2 to indicate which safety limit stopped the ice machine.

After safety limit indication, the ice machine will restart and run until a safety limit is exceeded again.

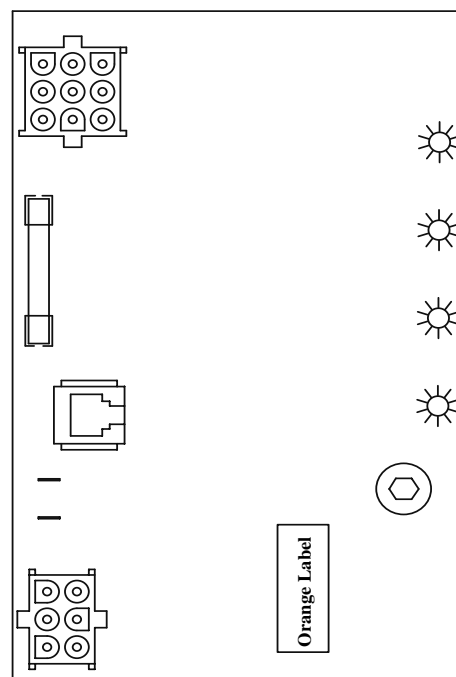

**Analyzing Why Safety Limits May Stop the Ice Machine**

According to the refrigeration industry, a high percentage of compressors fail as a result of external causes. These can include: flooding or starving expansion valves, dirty condensers, water loss to the ice machine, etc. The safety limits protect the ice machine (primarily the compressor) from external failures by stopping ice machine operation before major component damage occurs.

The safety limit system is similar to a high pressure cut-out control. It stops the ice machine, but does not tell what is wrong. The service technician must analyze the system to determine what caused the high pressure cut-out, or a particular safety limit, to stop the ice machine.

The safety limits are designed to stop the ice machine prior to major component failures, most often a minor problem or something external to the ice machine. This may be difficult to diagnose, as many external problems occur intermittently.

Example: An ice machine stops intermittently on safety limit #1 (long freeze times). The problem could be a low ambient temperature at night, a water pressure drop, the water is turned off one night a week, etc.

When a high pressure cut-out or a safety limit stops the ice machine, they are doing what they are supposed to do. That is, stopping the ice machine before a major component failure occurs.

Refrigeration and electrical component failures may also trip a safety limit. Eliminate all electrical components and external causes first. If it appears that the refrigeration system is causing the problem, use Manitowoc's Refrigeration System Operational Analysis Table, along with detailed charts, checklists, and other references to determine the cause.

The following checklists are designed to assist the service technician in analysis. However, because there are many possible external problems, do not limit your diagnosis to only the items listed.

**Safety Limit #1**

Refer to page 7-13 for control board identification and safety limit operation.

**Control Board with Black Microprocessor** - Freeze Time exceeds 60 minutes for 3 consecutive freeze cycles

or

**Control Board with Orange Label on Microprocessor** - Freeze time exceeds 60 minutes for 6 consecutive freeze cycles.

| Possible Cause  | Check/Correct   |
|---|---|
| Improper installation                                 | See "Installation/Visual Inspection Checklist" on <b>Page 7-10</b>  |
| Water system  | Low water pressure (20 psi min.)<br>High water pressure (80 psi max.)<br>High water temperature (90°F/32.2°C max.)<br>Clogged water distribution tube<br>Dirty/defective water fill valve<br>Dirty/defective water dump valve<br>Defective water pump   |
| Electrical system                                     | Ice thickness probe out of adjustment<br>Harvest cycle not initiated electrically<br>Contactor not energizing<br>Compressor electrically non-operational  |
| Restricted condenser air flow (air-cooled models)     | High inlet air temperature (110°F/43.3°C max.)<br>Condenser discharge air recirculation<br>Dirty condenser filter<br>Dirty condenser fins<br>Defective fan cycling control<br>Defective fan motor   |
| Restricted condenser water flow (water-cooled models) | Low water pressure (20 psi min.)<br>High water temperature (90°F/32.2°C max.)<br>Dirty condenser<br>Dirty/defective water regulating valve<br>Water regulating valve out of adjustment  |
| Refrigeration system                                  | Non-Manitowoc components<br>Improper refrigerant charge<br>Defective head pressure control (remotes)<br>Defective hot gas valve<br>Defective compressor<br>TXV starving or flooding (check bulb mounting)<br>Non-condensables in refrigeration system<br>Plugged or restricted high side refrigerant lines or component |

**SAFETY LIMIT NOTES**

- Because there are many possible external problems, do not limit your diagnosis to only the items listed in this chart.
- A continuous run of 100 harvests automatically erases the safety limit code.
- The control board will store and indicate only one safety limit – the last one exceeded.
- If the toggle switch is moved to the OFF position and then back to the ICE position prior to reaching the 100-harvest point, the last safety limit exceeded will be indicated.
- If the harvest light did not flash prior to the ice machine restarting, then the ice machine did not stop because it exceeded a safety limit.

**Safety Limit #2**

Refer to page 7-13 for control board identification and safety limit operation.

**Control Board with Black Microprocessor** - Harvest time exceeds 3.5 minutes for 3 consecutive harvest cycles.

or

**Control Board with Orange Label on Microprocessor** - Harvest time exceeds 3.5 minutes for 500 consecutive harvest cycles.

| Possible Cause        | Check/Correct  |
|-----------------------|--|
| Improper installation | See "Installation/Visual Inspection Checklist" on <b>Page 7-10</b>   |
| Water system          | Water area (evaporator) dirty<br>Dirty/defective water dump valve<br>Vent tube not installed on water outlet drain<br>Water freezing behind evaporator<br>Plastic extrusions and gaskets not securely mounted to the evaporator<br>Low water pressure (20 psi min.)<br>Loss of water from sump area<br>Clogged water distribution tube<br>Dirty/defective water fill valve<br>Defective water pump |
| Electrical system     | Ice thickness probe out of adjustment<br>Ice thickness probe dirty<br>Bin switch defective<br>Premature harvest  |
| Refrigeration system  | Non-Manitowoc components<br>Water regulating valve dirty/defective<br>Improper refrigerant charge<br>Defective head pressure control valve (remotes)<br>Defective harvest pressure control (HPR) valve (remotes)<br>Defective hot gas valve<br>TXV flooding (check bulb mounting)<br>Defective fan cycling control   |

**SAFETY LIMIT NOTES**

- Because there are many possible external problems, do not limit your diagnosis to only the items listed in this chart.
- A continuous run of 100 harvests automatically erases the safety limit code.
- The control board will store and indicate only one safety limit – the last one exceeded.
- If the toggle switch is moved to the OFF position and then back to the ICE position prior to reaching the 100-harvest point, the last safety limit exceeded will be indicated.
- If the harvest light did not flash prior to the ice machine restarting, then the ice machine did not stop because it exceeded a safety limit.

**ANALYZING DISCHARGE PRESSURE DURING FREEZE OR HARVEST CYCLE**

**Procedure**

1. Determine the ice machine operating conditions:

- Air temp. entering condenser \_\_\_\_\_
- Air temp. around ice machine \_\_\_\_\_
- Water temp. entering sump trough \_\_\_\_\_

2. Refer to Operating Pressure Chart for ice machine being checked. (These charts begin on **Page 7-33**.)

Use the operating conditions determined in step 1 to find the published normal discharge pressures.

Freeze Cycle \_\_\_\_\_ Harvest Cycle \_\_\_\_\_

3. Perform an actual discharge pressure check.

|                    | Freeze<br>Cycle PSIG | Harvest<br>Cycle PSIG |
|--------------------|----------------------|-----------------------|
| Beginning of Cycle | _____                | _____                 |
| Middle of Cycle    | _____                | _____                 |
| End of Cycle       | _____                | _____                 |

4. Compare the actual discharge pressure (step 3) with the published discharge pressure (step 2).

The discharge pressure is normal when the actual pressure falls within the published pressure range for the ice machine's operating conditions.

**Freeze Cycle Discharge Pressure High Checklist**

| Possible Cause  | Check/Correct   |
|---|---|
| Improper installation                                 | See "Installation/Visual Inspection Checklist" on <b>Page 7-10</b>  |
| Restricted condenser air flow (air-cooled models)     | High inlet air temperature (110°F/43.3°C max.)<br>Condenser discharge air recirculation<br>Dirty condenser filter<br>Dirty condenser fins<br>Defective fan cycling control<br>Defective fan motor |
| Restricted condenser water flow (water-cooled models) | Low water pressure (20 psi min.)<br>High inlet water temperature (90°F/32.2°C max.)<br>Dirty condenser<br>Dirty/defective water regulating valve<br>Water regulating valve out of adjustment      |
| Improper refrigerant charge                           | Overcharged<br>Non-condensables in system<br>Wrong type of refrigerant  |
| Other   | Non-Manitowoc components in system<br>High side refrigerant lines/component restricted (before mid-condenser)<br>Defective head pressure control valve (remote models)                            |

**Freeze Cycle Discharge Pressure Low Checklist**

| Possible Cause                                   | Check/Correct  |
|--|--|
| Improper installation                            | See "Installation/Visual Inspection Checklist" on <b>Page 7-10</b>   |
| Improper refrigerant charge                      | Undercharged<br>Wrong type of refrigerant  |
| Water regulating valve (water-cooled condensers) | Out of adjustment<br>Defective   |
| Other  | Non-Manitowoc components in system<br>Defective head pressure control valve (remote models)<br>Defective fan cycle control |

NOTE: Do not limit your diagnosis to only the items listed in the checklists.

**ANALYZING SUCTION PRESSURE DURING FREEZE CYCLE**

NOTE: Analyze discharge pressure before analyzing suction pressure. High or low discharge pressure may be causing high or low suction pressure.

The suction pressure gradually drops throughout the freeze cycle. The actual suction pressure (and drop rate) changes as the air and water temperatures entering the ice machine change. This affects freeze cycle times.

To analyze and identify the proper suction pressure drop throughout the freeze cycle, compare the published suction pressure to the published freeze cycle time. "Operating Pressure" and "Freeze Cycle Time" charts can be found later in this section.

**Procedure**

| Step  | Example Using QY0454A Model Ice Machine   |                    |  |        |    |    |   |   |   |    |    |                                     |  |  |  |  |  |  |    |    |    |    |    |    |
|---|---|--------------------|--|--------|----|----|---|---|---|----|----|-------------------------------------|--|--|--|--|--|--|----|----|----|----|----|----|
| 1. Determine the ice machine operating conditions.  | Air temp. entering condenser:   |                    | 90°F/32.2°C                              |        |    |    |   |   |   |    |    |                                     |  |  |  |  |  |  |    |    |    |    |    |    |
| 2A. Refer to "Cycle Time" and "Operating Pressure" charts for ice machine model being checked. Using operating conditions from Step 1, determine published freeze cycle time and published freeze cycle suction pressure. | Air temp. around ice machine:   |                    | 80°F/26.7°C                              |        |    |    |   |   |   |    |    |                                     |  |  |  |  |  |  |    |    |    |    |    |    |
|   | Water temp. entering water fill valve:  |                    | 70°F/21.1°C                              |        |    |    |   |   |   |    |    |                                     |  |  |  |  |  |  |    |    |    |    |    |    |
| 2B. Compare the published freeze cycle time and published freeze cycle suction pressure. Develop a chart.   | Published freeze cycle time:  |                    | Published freeze cycle suction pressure: |        |    |    |   |   |   |    |    |                                     |  |  |  |  |  |  |    |    |    |    |    |    |
|   | <u>13.7 - 14.1</u> minutes  |                    | <u>55-36</u> PSIG                        |        |    |    |   |   |   |    |    |                                     |  |  |  |  |  |  |    |    |    |    |    |    |
| 3. Perform an actual suction pressure check at the beginning, middle and end of the freeze cycle. Note the times at which the readings are taken.   | Published Freeze Cycle Time (minutes)   |                    |  |        |    |    |   |   |   |    |    |                                     |  |  |  |  |  |  |    |    |    |    |    |    |
|   | <table style="width:100%; border:none;"> <tr> <td style="text-align:center;">1</td> <td style="text-align:center;">3</td> <td style="text-align:center;">5</td> <td style="text-align:center;">7</td> <td style="text-align:center;">9</td> <td style="text-align:center;">12</td> <td style="text-align:center;">14</td> </tr> <tr> <td colspan="7" style="text-align:center;"> ----- ----- ----- ----- ----- ----- </td> </tr> <tr> <td style="text-align:center;">55</td> <td style="text-align:center;">52</td> <td style="text-align:center;">48</td> <td style="text-align:center;">44</td> <td style="text-align:center;">41</td> <td style="text-align:center;">38</td> <td style="text-align:center;">36</td> </tr> </table> |                    |  |        | 1  | 3  | 5 | 7 | 9 | 12 | 14 | ----- ----- ----- ----- ----- ----- |  |  |  |  |  |  | 55 | 52 | 48 | 44 | 41 | 38 |
| 1   | 3   | 5                  | 7  | 9      | 12 | 14 |   |   |   |    |    |                                     |  |  |  |  |  |  |    |    |    |    |    |    |
| ----- ----- ----- ----- ----- -----   |   |                    |  |        |    |    |   |   |   |    |    |                                     |  |  |  |  |  |  |    |    |    |    |    |    |
| 55  | 52  | 48                 | 44                                       | 41     | 38 | 36 |   |   |   |    |    |                                     |  |  |  |  |  |  |    |    |    |    |    |    |
| 4. Compare the actual freeze cycle suction pressure (Step 3) to the published freeze cycle time and pressure comparison (Step 2B). Determine if the suction pressure is high, low or acceptable.                          | Beginning of freeze cycle:  |                    | <u>59</u> PSIG at <u>1</u> minute        |        |    |    |   |   |   |    |    |                                     |  |  |  |  |  |  |    |    |    |    |    |    |
|   | Middle of freeze cycle:   |                    | <u>48</u> PSIG at <u>7</u> minutes       |        |    |    |   |   |   |    |    |                                     |  |  |  |  |  |  |    |    |    |    |    |    |
|   | End of freeze cycle:  |                    | <u>40</u> PSIG at <u>14</u> minutes      |        |    |    |   |   |   |    |    |                                     |  |  |  |  |  |  |    |    |    |    |    |    |
|   | Time Into Freeze Cycle  | Published Pressure | Actual Pressure                          | Result |    |    |   |   |   |    |    |                                     |  |  |  |  |  |  |    |    |    |    |    |    |
| 1 minutes   | 55 PSIG   | 59 PSIG            | High                                     |        |    |    |   |   |   |    |    |                                     |  |  |  |  |  |  |    |    |    |    |    |    |
| 7 minutes   | 44 PSIG   | 48 PSIG            | High                                     |        |    |    |   |   |   |    |    |                                     |  |  |  |  |  |  |    |    |    |    |    |    |
| 14 minutes  | 36 PSIG   | 40 PSIG            | High                                     |        |    |    |   |   |   |    |    |                                     |  |  |  |  |  |  |    |    |    |    |    |    |

**Freeze Cycle Suction Pressure High Checklist**

| Possible Cause              | Check/Correct   |
|-----------------------------|---|
| Improper installation       | See "Installation/Visual Inspection Checklist" on <b>Page 7-10</b>  |
| Discharge pressure          | Discharge pressure is too high, and is affecting low side<br>(See "Freeze Cycle Discharge Pressure High Checklist" on <b>Page 7-16</b> )                |
| Improper refrigerant charge | Overcharged<br>Wrong type of refrigerant  |
| Other                       | Non-Manitowoc components in system<br>H.P.R. solenoid leaking<br>Hot gas valve stuck open<br>TXV flooding (check bulb mounting)<br>Defective compressor |

**Freeze Cycle Suction Pressure Low Checklist**

| Possible Cause              | Check/Correct  |
|-----------------------------|--|
| Improper installation       | See "Installation/Visual Inspection Checklist" on <b>Page 7-10</b>   |
| Discharge pressure          | Discharge pressure is too low, and is affecting low side<br>(See "Freeze Cycle Discharge Pressure Low Checklist" on <b>Page 7-16</b> )   |
| Improper refrigerant charge | Undercharged<br>Wrong type of refrigerant  |
| Other                       | Non-Manitowoc components in system<br>Improper water supply over evaporator (See "Water System Checklist" on page 7-10)<br>Loss of heat transfer from tubing on back side of evaporator<br>Restricted/plugged liquid line drier<br>Restricted/plugged tubing in suction side of refrigeration system<br>TXV starving |

NOTE: Do not limit your diagnosis to only the items listed in the checklists.

**SINGLE EXPANSION VALVE ICE MACHINES -  
COMPARING EVAPORATOR INLET AND  
OUTLET TEMPERATURES**

NOTE: This procedure will not work on the dual expansion valve Q1300 Q1600 and Q1800 ice machines.

The temperatures of the suction lines entering and leaving the evaporator alone cannot diagnose an ice machine. However, comparing these temperatures during the freeze cycle, along with using Manitowoc's Refrigeration System Operational Analysis Table, can help diagnose an ice machine malfunction.

The actual temperatures entering and leaving the evaporator vary by model, and change throughout the freeze cycle. This makes documenting the "normal" inlet and outlet temperature readings difficult. The key to the diagnosis lies in the difference between the two temperatures five minutes into the freeze cycle. These temperatures must be within 7° of each other.

Use this procedure to document freeze cycle inlet and outlet temperatures.

1. Use a quality temperature meter, capable of taking temperature readings on curved copper lines.
2. Attach the temperature meter sensing device to the copper lines entering and leaving the evaporator.

**Important**

Do not simply insert the sensing device under the insulation. It must be attached to and reading the actual temperature of the copper line.

3. Wait five minutes into the freeze cycle.
4. Record the temperatures below and determine the difference between them.
5. Use this with other information gathered on the Refrigeration System Operational Analysis Table to determine the ice machine malfunction.

|   |                    |
|---|--------------------|
| Inlet Temperature                                 | Outlet Temperature |
| Difference  |                    |
| Must be within 7°F at 5 minutes into freeze cycle |                    |



**HOT GAS VALVE TEMPERATURE CHECK**

NOTE: This procedure requires checking both hot gas valves on dual expansion valve Q1300 and Q1800 ice machines.

**General**

A hot gas valve requires a critical orifice size. This meters the amount of hot gas flowing into the evaporator during the harvest cycle. If the orifice is even slightly too large or too small, long harvest cycles will result.

A too-large orifice causes refrigerant to condense to liquid in the evaporator during the harvest cycle. This liquid will cause compressor damage. A too-small orifice does not allow enough hot gas into the evaporator. This causes low suction pressure, and insufficient heat for a harvest cycle.

Normally, a defective hot gas valve can be rebuilt. Refer to the Parts Manual for proper valve application and rebuild kits. If replacement is necessary, Use only “original” Manitowoc replacement parts.

**Hot Gas Valve Analysis**

Symptoms of a hot gas valve remaining partially open during the freeze cycle can be similar to symptoms of either an expansion valve or compressor problem. The best way to diagnose a hot gas valve is by using Manitowoc’s Ice Machine Refrigeration System Operational Analysis Table.

Use the following procedure and table to help determine if a hot gas valve is remaining partially open during the freeze cycle.

1. Wait five minutes into the freeze cycle.
2. Feel the inlet of the hot gas valve(s).

3. Feel the compressor discharge line.

**⚠ Warning**

The inlet of the hot gas valve and the compressor discharge line could be hot enough to burn your hand. Just touch them momentarily.

4. Compare the temperature of the inlet of the hot gas valves to the temperature of the compressor discharge line.

| Findings   | Comments  |
|--|---|
| The inlet of the hot gas valve is cool enough to touch and the compressor discharge line is hot.         | This is normal as the discharge line should always be too hot to touch and the hot gas valve inlet, although too hot to touch during harvest, should be cool enough to touch after 5 minutes into the freeze cycle.   |
| The inlet of the hot gas valve is hot and approaches the temperature of a hot compressor discharge line. | This is an indication something is wrong, as the hot gas valve inlet did not cool down during the freeze cycle. If the compressor dome is also entirely hot, the problem is not a hot gas valve leaking, but rather something causing the compressor (and the entire ice machine) to get hot. |
| Both the inlet of the hot gas valve and the compressor discharge line are cool enough to touch.          | This is an indication something is wrong, causing the compressor discharge line to be cool to the touch. This is not caused by a hot gas valve leaking.   |

**Important**

Feeling the hot gas valve outlet or across the hot gas valve itself will not work for this comparison. The hot gas valve outlet is on the suction side (cool refrigerant). It may be cool enough to touch even if the valve is leaking.

**DISCHARGE LINE TEMPERATURE ANALYSIS****General**

Knowing if the discharge line temperature is increasing, decreasing or remaining constant can be an important diagnostic tool. Maximum compressor discharge line temperature on a normally operating ice machine steadily increases throughout the freeze cycle. Comparing the temperatures over several cycles will result in a consistent maximum discharge line temperature.

Ambient air temperatures affect the maximum discharge line temperature.

Higher ambient air temperatures at the condenser = higher discharge line temperatures at the compressor.

Lower ambient air temperatures at the condenser = lower discharge line temperatures at the compressor.

Regardless of ambient temperature, the freeze cycle discharge line temperature will be higher than 160°F on a normally operating ice machine.

**Procedure**

Connect a temperature probe on the compressor discharge line with-in 6" of the compressor and insulate.

Observe the discharge line temperature for the last three minutes of the freeze cycle and record the maximum discharge line temperature.

**Discharge Line Temperature Above 160°F At End Of Freeze Cycle:**

Ice machines that are operating normally will have consistent maximum discharge line temperatures above 160°F.

**Discharge Line Temperature Below 160°F At End Of Freeze Cycle**

Ice machines that have a flooding expansion valve will have a maximum discharge line temperature that decreases each cycle.

Verify the expansion valve sensing bulb is 100% insulated and sealed airtight. Condenser air contacting an incorrectly insulated sensing bulb will cause overfeeding of the expansion valve.

Verify the expansion valve sensing bulb is positioned and secured correctly.

THIS PAGE INTENTIONALLY LEFT BLANK

## HOW TO USE THE REFRIGERATION SYSTEM OPERATIONAL ANALYSIS TABLES

### General

These tables must be used with charts, checklists and other references to eliminate refrigeration components not listed on the tables and external items and problems which can cause good refrigeration components to appear defective.

The tables list five different defects that may affect the ice machine's operation.

NOTE: A low-on-charge ice machine and a starving expansion valve have very similar characteristics and are listed under the same column.

NOTE: Before starting, see "Before Beginning Service" on **Page 7-9** for a few questions to ask when talking to the ice machine owner.

### Procedure

**Step 1** Complete the "Operation Analysis" column.

Read down the left "Operational Analysis" column. Perform all procedures and check all information listed. Each item in this column has supporting reference material to help analyze each step.

While analyzing each item separately, you may find an "external problem" causing a good refrigerant component to appear bad. Correct problems as they are found. If the operational problem is found, it is not necessary to complete the remaining procedures.

**Step 2** Enter check marks (✓) in the small boxes.

Each time the actual findings of an item in the "Operational Analysis" column matches the published findings on the table, enter a check mark.

Example: Freeze cycle suction pressure is determined to be low. Enter a check mark in the "low" box.

**Step 3** Add the check marks listed under each of the four columns. Note the column number with the highest total and proceed to "Final Analysis."

NOTE: If two columns have matching high numbers, a procedure was not performed properly and/or supporting material was not analyzed correctly.

### Final Analysis

The column with the highest number of check marks identifies the refrigeration problem.

#### COLUMN 1 - HOT GAS VALVE LEAKING

Normally, a leaking hot gas valve can be repaired with a rebuild kit instead of changing the entire valve. Rebuild or replace the valve as required.

#### COLUMN 2 - LOW CHARGE/TXV STARVING

Normally, a starving expansion valve only affects the freeze cycle pressures, not the harvest cycle pressures. A low refrigerant charge normally affects both pressures. Verify the ice machine is not low on charge before replacing an expansion valve.

1. Add refrigerant charge in 2 to 4 oz. increments as a diagnostic procedure to verify a low charge. If the problem is corrected, the ice machine is low on charge. Find the refrigerant leak.

The ice machine must operate with the nameplate charge. If the leak cannot be found, proper refrigerant procedures must still be followed. Change the liquid line drier. Then, evacuate and weigh in the proper charge.

2. If the problem is not corrected by adding charge, the expansion valve is faulty.

On dual expansion valve ice machines, change only the TXV that is starving. If both TXV's are starving, they are probably good, and are being affected by some other malfunction, such as low charge.

#### COLUMN 3 - TXV FLOODING

A loose or improperly mounted expansion valve bulb causes the expansion valve to flood. Check bulb mounting, insulation, etc., before changing the valve. On dual expansion valve machines, the service technician should be able to tell which TXV is flooding by analyzing ice formation patterns. Change only the flooding expansion valve.

#### COLUMN 4 - COMPRESSOR

Replace the compressor and start components. To receive warranty credit, the compressor ports must be properly sealed by crimping and soldering them closed. Old start components must be returned with the faulty compressor.

REFRIGERATION SYSTEM OPERATIONAL ANALYSIS TABLES



Q, J and B Model Single Expansion Valve

This table must be used with charts, checklists and other references to eliminate refrigeration components not listed on the table and external items and problems, which can cause good refrigeration components to appear defective.

| Operational Analysis  | 1  | 2   | 3  | 4   |
|---|--|---|--|---|
| <b>Ice Production</b>   | Air-Temperature Entering Condenser _____<br>Water Temperature Entering Ice Machine _____<br>Published 24 hour ice production _____<br>Calculated (actual) ice production _____<br>NOTE: The ice machine is operating properly if the ice fill patterns is normal and ice production is within 10% of charted capacity. |   |  |   |
| <b>Installation and Water System</b>  | All installation and water related problems must be corrected before proceeding with chart.  |   |  |   |
| <b>Ice Formation Pattern</b><br>Normal _____<br>Extremely Thin at Outlet _____<br>Extremely Thin at Inlet _____<br>No Ice _____   | Ice formation is extremely thin on top of evaporator<br>-or-<br>No ice formation on the entire evaporator  | Ice formation is extremely thin on top of evaporator<br>-or-<br>No ice formation on entire evaporator             | Ice formation normal<br>-or-<br>Ice formation is extremely thin on bottom of evaporator<br>-or-<br>No ice formation on entire evaporator                 | Ice formation normal<br>-or-<br>No ice formation on entire evaporator   |
| <b>Safety Limits</b><br>Refer to "Analyzing Safety Limits" to eliminate all non-refrigeration problems.   | Stops on safety limit:<br>1  | Stops on safety limit:<br>1   | Stops on safety limit:<br>1 or 2   | Stops on safety limit:<br>1   |
| <b>Freeze Cycle Discharge Pressure</b><br>_____ Middle _____<br>1 minute into cycle End   | If discharge pressure is High or Low refer to freeze cycle high or low discharge pressure problem checklist to eliminate problems and/or components not listed on this table before proceeding.  |   |  |   |
| <b>Freeze Cycle Suction Pressure</b><br>_____ Middle _____<br>1 minute into cycle End   | If suction pressure is High or Low refer to freeze cycle high or low suction pressure problem checklist to eliminate problems and/or components not listed on this table before proceeding.  |   |  |   |
|   | Suction pressure is <b>High</b>  | Suction pressure is <b>Low or Normal</b>  | Suction pressure is <b>High</b>  | Suction pressure is <b>High</b>   |
| Wait 5 minutes into the freeze cycle.<br>Compare temperatures of <b>evaporator inlet</b> and <b>evaporator outlet</b> .<br>Inlet _____ °F<br>Outlet _____ °F<br>Difference _____ °F | Inlet and outlet <b>within 7°F</b> of each other   | Inlet and outlet <b>not within 7°F</b> of each other<br>-and-<br>Inlet is colder than outlet                      | Inlet and outlet <b>within 7°F</b> of each other<br>-or-<br>Inlet and outlet <b>not within 7°F</b> of each other<br>-and-<br>Inlet is warmer than outlet | Inlet and outlet <b>within 7°F</b> of each other  |
| Wait 5 minutes into the freeze cycle.<br>Compare temperatures of <b>compressor discharge line</b> and <b>hot gas valve inlet</b> .  | The hot gas valve inlet is <b>Hot</b> -and- approaches the temperature of a <b>Hot</b> compressor discharge line.  | The hot gas valve inlet is <b>Cool</b> enough to hold hand on -and- the compressor discharge line is <b>Hot</b> . | The hot gas valve inlet is <b>Cool</b> enough to hold hand on -and- the compressor discharge line is <b>Cool</b> enough to hold hand on.                 | The hot gas valve inlet is <b>Cool</b> enough to hold hand on -and- the compressor discharge line is <b>Hot</b> . |
| <b>Discharge Line Temperature</b><br>Record freeze cycle discharge line temperature at the end of the freeze cycle<br><br>_____ °F  | Discharge line temperature <b>160°F or higher</b> at the end of the freeze cycle   | Discharge line temperature <b>160°F or higher</b> at the end of the freeze cycle                                  | Discharge line temperature <b>less than 160°F</b> at the end of the freeze cycle   | Discharge line temperature <b>160°F or higher</b> at the end of the freeze cycle                                  |
| <b>Final Analysis</b><br>Enter total number of boxes checked in each column.  | <b>Hot Gas Valve Leaking</b>   | <b>Low On Charge</b><br>-Or-<br><b>TXV Starving</b>   | <b>TXV Flooding</b>  | <b>Compressor</b>   |



**Q and J Model Dual Expansion Valve**

This table must be used with charts, checklists and other references to eliminate refrigeration components not listed on the table and external items and problems, which can cause good refrigeration components to appear defective.

| Operational Analysis   | 1  | 2  | 3  | 4  |
|--|--|--|--|--|
| <b>Ice Production</b><br>Air-Temperature Entering Condenser _____<br>Water Temperature Entering Ice Machine _____<br>Published 24 hour ice production _____<br>Calculated (actual) ice production _____<br>NOTE: The ice machine is operating properly if the ice production and ice formation pattern is normal and ice production is within 10% of charted capacity. |  |  |  |  |
| <b>Ice Formation Pattern</b><br>Left side _____<br>_____<br>Right side _____<br>_____  | Ice formation is extremely thin on top of one side of evaporator<br>-or-<br>No ice formation on one side of evaporator   | Ice formation is extremely thin on top of one or both sides of evaporator<br>-or-<br>No ice formation on entire evaporator | Ice formation normal<br>-or-<br>Ice formation is extremely thin on bottom of one side of evaporator<br>-or-<br>No ice formation on entire evaporator | Ice formation normal<br>-or-<br>No ice formation on entire evaporator  |
| <b>Safety limits</b><br>Refer to "Analyzing Safety Limits" to eliminate problems and/or components not listed on this table  | Stops on safety limit: 1   | Stops on safety limit: 1   | Stops on safety limit: 1 or 2  | Stops on safety limit: 1   |
| <b>Freeze Cycle DISCHARGE pressure</b><br>_____ Middle _____ End _____<br>1 minute into cycle  | If discharge pressure is <b>High or Low</b> refer to a freeze cycle high or low discharge pressure problem checklist to eliminate problems and/or components not listed on this table before proceeding. |  |  |  |
| <b>Freeze Cycle SUCTION pressure</b><br>_____ Middle _____ End _____<br>Beginning  | If suction pressure is <b>High or Low</b> refer to a freeze cycle high or low suction pressure problem checklist to eliminate problems and/or components not listed on this table before proceeding.     |  |  |  |
|  | Suction pressure is <b>High</b>  | Suction pressure is <b>Low or Normal</b>   | Suction pressure is <b>High</b>  | Suction pressure is <b>High</b>  |
| <b>Hot Gas Valve</b><br>Wait 5 minutes into the freeze cycle.<br>Compare temperatures of <b>compressor discharge line</b> and <b>both hot gas valve inlets</b> .   | One hot gas valve inlet is <b>Hot</b><br>-and-<br>approaches the temperature of a <b>Hot</b> compressor discharge line.  | Both hot gas valve inlets are <b>Cool</b> enough to hold hand on<br>-and-<br>the compressor discharge line is <b>Hot</b> . | Both hot gas valve inlets are <b>Cool</b> enough to hold hand on<br>-and-<br>the compressor discharge line is <b>Cool</b> enough to hold hand on.    | Both hot gas valve inlets are <b>Cool</b> enough to hold hand on<br>-and-<br>the compressor discharge line is <b>Hot</b> . |
| <b>Discharge Line Temperature</b><br>Record freeze cycle discharge line temperature at the end of the freeze cycle<br>_____ °F   | Discharge line temperature <b>160°F or higher</b> at the end of the freeze cycle   | Discharge line temperature <b>160°F or higher</b> at the end of the freeze cycle   | Discharge line temperature <b>less than 160°F</b> at the end of the freeze cycle   | Discharge line temperature <b>160°F or higher</b> at the end of the freeze cycle   |
| <b>Final Analysis</b><br>Enter total number of boxes checked in each column.   | <b>Hot Gas Valve Leaking</b>   | <b>Low On Charge -Or- TXV Starving</b>   | <b>TXV Flooding</b>  | <b>Compressor</b>  |

## HARVEST PRESSURE REGULATING (H.P.R.) SYSTEM

### Remotes Only

#### GENERAL

The harvest pressure regulating (H.P.R.) system includes:

- Harvest pressure regulating solenoid valve (H.P.R. solenoid). This is an electrically operated valve which opens when energized, and closes when de-energized.

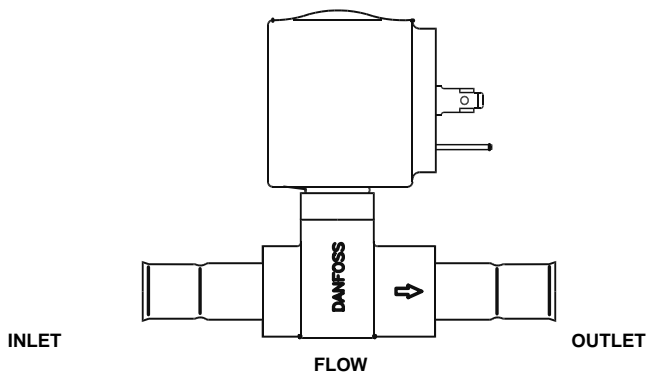

SV1427

**Figure 7-12. H.P.R. Solenoid**

- Harvest pressure regulating valve (H.P.R. valve). This is a non-adjustable pressure regulating valve which modulates open and closed, based on the refrigerant pressure at the outlet of the valve. The valve closes completely and stops refrigerant flow when the pressure at the outlet rises above the valve setting.

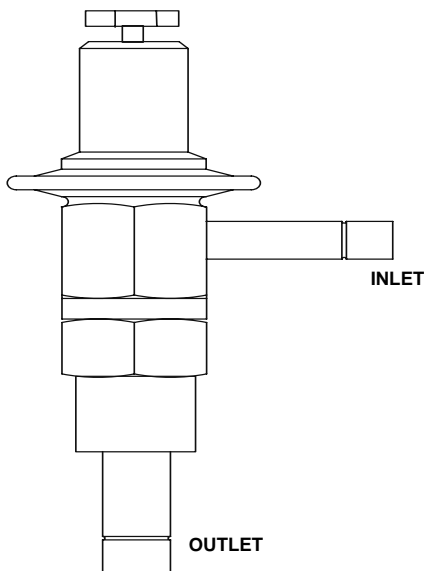

SV3053

**Figure 7-13. H.P.R. Valve**

#### FREEZE CYCLE

The H.P.R. system is not used during the freeze cycle. The H.P.R. solenoid is closed (de-energized), preventing refrigerant flow into the H.P.R. valve.

#### HARVEST CYCLE

During the harvest cycle, the check valve in the discharge line prevents refrigerant in the remote condenser and receiver from backfeeding into the evaporator and condensing to liquid.

The H.P.R. solenoid is opened (energized) during the harvest cycle, allowing refrigerant gas from the top of the receiver to flow into the H.P.R. valve. The H.P.R. valve modulates open and closed, raising the suction pressure high enough to sustain heat for the harvest cycle, without allowing refrigerant to condense to liquid in the evaporator.

In general, harvest cycle suction pressure rises, then stabilizes in the range of 75-100 psig (517-758 kPa).

Exact pressures vary from model to model. These can be found in the "Operational Refrigerant Pressures" charts, beginning on **Page 7-32**.

HPR DIAGNOSTICS

Steps 1 through 4 can be quickly verified without attaching a manifold gauge set or thermometer.

**All questions must have a yes answer to continue the diagnostic procedure.**

1. Liquid line warm?

(Body temperature is normal)

If liquid line is warmer or cooler than body temperature, refer to headmaster diagnostics.

2. Ice fill pattern normal?

Refer to "Ice Formation Pattern" if ice fill is not normal.

3. Freeze time normal?

(Refer to Cycle Times/Refrigerant Pressures/24 Hour Ice Production Charts)

**Shorter freeze cycles** - Refer to headmaster diagnostics.

**Longer freeze cycles** - Refer to water system checklist, then refer to Refrigeration Diagnostic Procedures.

4. Harvest time is longer than normal and control board indicates safety limit #2?

(Refer to Cycle Times/Refrigerant Pressures/24 Hour Ice Production Charts)

Connect refrigeration manifold gauge set to the access valves on the front of the ice machine, and a thermometer thermocouple on the discharge line within 6" of the compressor (insulate thermocouple).

5. Establish baseline by recording suction and discharge pressure, discharge line temperature and freeze & harvest cycle times. (Refer to section 7 "Operational Analysis" for data collection detail).

6. Freeze cycle Head Pressure 220 psig or higher?

If the head pressure is lower than 220 psig refer to headmaster diagnostics.

7. Freeze cycle Suction Pressure normal?

Refer to analyzing suction pressure if suction pressure is high or low.

8. Discharge line temperature is 160°F or higher at end of freeze cycle?

If less than 160°F check expansion valve bulb mounting and insulation.

9. Harvest cycle suction and discharge pressures are lower than indicated in the cycle times/refrigerant pressures/24 hour ice production chart?

Replace Harvest Pressure Regulating system (HPR Valve and HPR solenoid valve).



**HEADMASTER CONTROL VALVE**

Manitowoc remote systems require headmaster control valves with special settings. Replace defective headmaster control valves only with “original” Manitowoc replacement parts.

**Operation**

The R404A headmaster control valve is non adjustable. At ambient temperatures of approximately 70°F (21.1°C) or above, refrigerant flows through the valve from the condenser to the receiver inlet. At temperatures below this (or at higher temperatures if it is raining), the head pressure control dome’s nitrogen charge closes the condenser port and opens the bypass port from the compressor discharge line.

In this modulating mode, the valve maintains minimum head pressure by building up liquid in the condenser and bypassing discharge gas directly to the receiver.

**Diagnosing**

1. Determine the air temperature entering the remote condenser.
2. Determine if the head pressure is high or low in relationship to the outside temperature. (Refer to the proper “Operational Pressure Chart” later in this section.) If the air temperature is below 70°F (21.1°C), the head pressure should be modulating about 225 PSIG.
3. Determine the temperature of the liquid line entering the receiver by feeling it. This line is normally warm; “body temperature.”
4. Using the information gathered, refer to the chart below.

**NOTE:** A headmaster that will not bypass, will function properly with condenser air temperatures of approximately 70°F (21.1°C) or above. When the temperature drops below 70°F (21.1°C), the headmaster fails to bypass and the ice machine malfunctions. Lower ambient conditions can be simulated by rinsing the condenser with cool water during the freeze cycle.

| Symptom  | Probable Cause            | Corrective Measure   |
|--|---------------------------|--|
| Valve not maintaining pressures  | Non-approved valve        | Install a Manitowoc Headmaster control valve with proper setting |
| Discharge pressure extremely high; Liquid line entering receiver feels hot | Valve stuck in bypass     | Replace valve  |
| Discharge pressure low; Liquid line entering receiver feels extremely cold | Valve not bypassing       | Replace valve  |
| Discharge pressure low; Liquid line entering receiver feels warm to hot    | Ice machine low on charge | See “Low on Charge Verification” on <b>Page 7-31</b>             |

**LOW ON CHARGE VERIFICATION**

The remote ice machine requires more refrigerant charge at lower ambient temperatures than at higher temperatures. A low on charge ice machine may function properly during the day, and then malfunction at night. Check this possibility.

If you cannot verify that the ice machine is low on charge:

1. Add refrigerant in 2 lb. increments, but do not exceed 6 lbs.
2. If the ice machine was low on charge, the headmaster function and discharge pressure will return to normal after the charge is added. Do not let the ice machine continue to run. To assure operation in all ambient conditions, the refrigerant leak must be found and repaired, the liquid line drier must be changed, and the ice machine must be evacuated and properly recharged.
3. If the ice machine does not start to operate properly after adding charge, replace the headmaster.

**FAN CYCLE CONTROL VS. HEADMASTER**

A fan cycle control cannot be used in place of a headmaster. The fan cycle control is not capable of bypassing the condenser coil and keeping the liquid line temperature and pressure up.

This is very apparent when it rains or the outside temperature drops. When it rains or the outside temperature drops, the fan begins to cycle on and off. At first, everything appears normal. But, as it continues raining or getting colder, the fan cycle control can only turn the fan off. All the refrigerant must continue to flow through the condenser coil, being cooled by the rain or low outside temperature.

This causes excessive sub-cooling of the refrigerant. As a result, the liquid line temperature and pressure are not maintained for proper operation.

**Pressure Control Specifications and Diagnostics**

**FAN CYCLE CONTROL**

(Self-Contained Air-Cooled Models Only)

**Function**

Cycles the fan motor on and off to maintain proper operating discharge pressure.

The fan cycle control closes on an increase, and opens on a decrease in discharge pressure.

**Specifications**

| Model                                    | Cut-In (Close) | Cut-Out (Open) |
|--|----------------|----------------|
| Q200/Q280<br>Q320/Q370/Q420<br>Q450/Q600 | 250 psig ±5    | 200 psig ±5    |
| Q800/Q1000<br>Q1300/Q1600<br>Q1800       | 275 psig ±5    | 225 psig ±5    |

**Check Procedure**

1. Verify fan motor windings are not open or grounded, and fan spins freely.
2. Connect manifold gauges to ice machine.
3. Hook voltmeter in parallel across the fan cycle control, leaving wires attached.
4. Refer to chart below.

| At:           | Reading Should Be: | Fan Should Be: |
|---------------|--------------------|----------------|
| above cut-in  | 0 volts            | running        |
| below cut-out | line voltage       | off            |

**HIGH PRESSURE CUT-OUT (HPCO) CONTROL**

**Function**

Stops the ice machine if subjected to excessive high-side pressure.

The HPCO control is normally closed, and opens on a rise in discharge pressure.

**Specifications**

Cut-out: 450 psig ±10

Cut-in: Manual or automatic reset  
(Must be below 300 psig to reset).

**Check Procedure**

1. Set ICE/OFF/CLEAN switch to OFF, (Manual reset HPCO reset if tripped).
2. Connect manifold gauges.
3. Hook voltmeter in parallel across the HPCO, leaving wires attached.
4. On water-cooled models, close the water service valve to the water condenser inlet. On self-contained air-cooled and remote models, disconnect the fan motor.
5. Set ICE/OFF/CLEAN switch to ICE.
6. No water or air flowing through the condenser will cause the HPCO control to open because of excessive pressure. Watch the pressure gauge and record the cut-out pressure.

** Warning**

If discharge pressure exceeds 460 psig and the HPCO control does not cut out, set ICE/OFF/CLEAN switch to OFF to stop ice machine operation.

Replace the HPCO control if it:

- Will not reset (below 300 psig)
- Does not open at the specified cut-out point

**Cycle Time/24 Hour Ice Production/  
Refrigerant Pressure Charts**

**Q200 SERIES**

**Self-Contained Air-Cooled**

NOTE: These characteristics may vary depending on operating conditions.

**Cycle Times**

Freeze Time + Harvest Time = Total Cycle Time

| Air Temp.<br>Entering<br>Condenser<br>°F/°C | Freeze Time             |           |           | Harvest<br>Time |
|---|-------------------------|-----------|-----------|-----------------|
|   | Water Temperature °F/°C |           |           |                 |
|   | 50/10.0                 | 70/21.1   | 90/32.2   |                 |
| 70/21.1                                     | 11.5-13.5               | 13.8-16.1 | 15.2-17.8 | 1.0-2.5         |
| 80/26.7                                     | 13.8-16.1               | 15.6-18.2 | 17.0-19.8 |                 |
| 90/32.2                                     | 16.1-18.7               | 18.6-21.6 | 20.5-23.8 |                 |
| 100/37.8                                    | 19.8-23.0               | 23.6-27.4 | 25.5-29.6 |                 |
| Times in minutes                            |                         |           |           |                 |

**24 Hour Ice Production**

| Air Temp.<br>Entering<br>Condenser<br>°F/°C                                     | Water Temperature °F/°C |         |         |
|---|-------------------------|---------|---------|
|   | 50/10.0                 | 70/21.1 | 90/32.2 |
| 70/21.1   | 270                     | 230     | 210     |
| 80/26.7   | 230                     | 205     | 190     |
| 90/32.2   | 200                     | 175     | 160     |
| 100/37.8  | 165                     | 140     | 130     |
| Based on average ice slab weight of 2.44 - 2.81 lb<br>Regular cube derate is 7% |                         |         |         |

**Operating Pressures**

| Air Temp.<br>Entering<br>Condenser<br>°F/°C                  | Freeze Cycle                  |                             | Harvest Cycle                 |                             |
|--|-------------------------------|-----------------------------|-------------------------------|-----------------------------|
|  | Discharge<br>Pressure<br>PSIG | Suction<br>Pressure<br>PSIG | Discharge<br>Pressure<br>PSIG | Suction<br>Pressure<br>PSIG |
| 50/10.0  | 195-260                       | 60-28                       | 120-190                       | 85-110                      |
| 70/21.1  | 195-260                       | 60-28                       | 120-190                       | 85-110                      |
| 80/26.7  | 210-270                       | 65-28                       | 160-190                       | 90-110                      |
| 90/32.2  | 240-290                       | 70-30                       | 190-210                       | 100-120                     |
| 100/37.8   | 270-330                       | 70-35                       | 220-240                       | 120-140                     |
| 110/43.3   | 310-390                       | 85-40                       | 250-270                       | 120-150                     |
| Suction pressure drops gradually throughout the freeze cycle |                               |                             |                               |                             |

**Q200 SERIES**

**Self-Contained Water-Cooled**

NOTE: These characteristics may vary depending on operating conditions.

**Cycle Times**

Freeze Time + Harvest Time = Total Cycle Time

| Air Temp.<br>Around Ice<br>Machine<br>°F/°C | Freeze Time             |           |           | Harvest<br>Time |
|---|-------------------------|-----------|-----------|-----------------|
|   | Water Temperature °F/°C |           |           |                 |
|   | 50/10.0                 | 70/21.1   | 90/32.2   |                 |
| 70/21.1                                     | 11.5-13.5               | 12.8-15.0 | 14.5-16.9 | 1-2.5           |
| 80/26.7                                     | 12.0-14.1               | 13.5-15.7 | 15.2-17.8 |                 |
| 90/32.2                                     | 12.6-14.7               | 14.1-16.5 | 16.1-18.7 |                 |
| 100/37.8                                    | 13.1-15.4               | 14.8-17.3 | 17.0-19.8 |                 |
| Times in minutes                            |                         |           |           |                 |

**24 Hour Ice Production**

| Air Temp.<br>Around Ice<br>Machine<br>°F/°C                                     | Water Temperature °F/°C |         |         |
|---|-------------------------|---------|---------|
|   | 50/10.0                 | 70/21.1 | 90/32.2 |
| 70/21.1   | 270                     | 245     | 220     |
| 80/26.7   | 260                     | 235     | 210     |
| 90/32.2   | 250                     | 225     | 200     |
| 100/37.8  | 240                     | 215     | 190     |
| Based on average ice slab weight of 2.44 - 2.81 lb<br>Regular cube derate is 7% |                         |         |         |

| Condenser<br>Water<br>Consumption                                  | 90/32.2 Air Temperature<br>Around Ice Machine |         |         |
|--|---|---------|---------|
|  | Water Temperature °F/°C                       |         |         |
|  | 50/10.0                                       | 70/21.1 | 90/32.2 |
| Gal/24 hours   | 240   | 480     | 2100    |
| Water regulating valve set to maintain 230 PSIG discharge pressure |   |         |         |

**Operating Pressures**

| Air Temp.<br>Around Ice<br>Machine<br>°F/°C                  | Freeze Cycle                  |                             | Harvest Cycle                 |                             |
|--|-------------------------------|-----------------------------|-------------------------------|-----------------------------|
|  | Discharge<br>Pressure<br>PSIG | Suction<br>Pressure<br>PSIG | Discharge<br>Pressure<br>PSIG | Suction<br>Pressure<br>PSIG |
| 50/10.0  | 225-235                       | 60-28                       | 170-200                       | 90-110                      |
| 70/21.1  | 225-235                       | 60-28                       | 170-200                       | 90-110                      |
| 80/26.7  | 225-240                       | 60-28                       | 175-205                       | 90-110                      |
| 90/32.2  | 225-245                       | 65-30                       | 175-205                       | 90-115                      |
| 100/37.8   | 225-250                       | 70-32                       | 180-210                       | 90-115                      |
| 110/43.3   | 225-260                       | 75-34                       | 185-215                       | 90-120                      |
| Suction pressure drops gradually throughout the freeze cycle |                               |                             |                               |                             |

**Q280 SERIES**

**Self-Contained Air-Cooled**

NOTE: These characteristics may vary depending on operating conditions.

**Cycle Times**

Freeze Time + Harvest Time = Total Cycle Time

| Air Temp. Entering Condenser °F/°C | Freeze Time             |           |           | Harvest Time |
|------------------------------------|-------------------------|-----------|-----------|--------------|
|                                    | Water Temperature °F/°C |           |           |              |
|                                    | 50/10.0                 | 70/21.1   | 90/32.2   |              |
| 70/21.1                            | 10.6-12.5               | 11.8-13.8 | 12.6-14.7 | 1.0-2.5      |
| 80/26.7                            | 11.5-13.5               | 12.8-15.0 | 13.8-16.1 |              |
| 90/32.2                            | 12.6-14.7               | 14.1-16.5 | 15.2-17.8 |              |
| 100/37.8                           | 14.5-16.9               | 16.5-19.3 | 18.0-21.0 |              |
| Times in minutes                   |                         |           |           |              |

**24 Hour Ice Production**

| Air Temp. Entering Condenser °F/°C  | Water Temperature °F/°C |         |         |
|---|-------------------------|---------|---------|
|   | 50/10.0                 | 70/21.1 | 90/32.2 |
| 70/21.1   | 290                     | 265     | 250     |
| 80/26.7   | 270                     | 245     | 230     |
| 90/32.2   | 250                     | 225     | 210     |
| 100/37.8  | 220                     | 195     | 180     |
| Based on average ice slab weight of 2.44 - 2.81 lb<br>Regular cube derate is 7% |                         |         |         |

**Operating Pressures**

| Air Temp. Entering Condenser °F/°C                           | Freeze Cycle            |                       | Harvest Cycle           |                       |
|--|-------------------------|-----------------------|-------------------------|-----------------------|
|  | Discharge Pressure PSIG | Suction Pressure PSIG | Discharge Pressure PSIG | Suction Pressure PSIG |
| 50/10.0  | 195-250                 | 60-20                 | 150-190                 | 70-90                 |
| 70/21.1  | 195-250                 | 60-20                 | 150-190                 | 70-90                 |
| 80/26.7  | 220-280                 | 60-26                 | 180-220                 | 70-90                 |
| 90/32.2  | 250-310                 | 66-30                 | 190-220                 | 80-100                |
| 100/37.8   | 280-350                 | 70-32                 | 220-250                 | 80-110                |
| 110/43.3   | 310-390                 | 85-40                 | 250-270                 | 80-120                |
| Suction pressure drops gradually throughout the freeze cycle |                         |                       |                         |                       |

**Q280 SERIES**

**Self-Contained Water-Cooled**

NOTE: These characteristics may vary depending on operating conditions.

**Cycle Times**

Freeze Time + Harvest Time = Total Cycle Time

| Air Temp. Around Ice Machine °F/°C | Freeze Time             |           |           | Harvest Time |
|------------------------------------|-------------------------|-----------|-----------|--------------|
|                                    | Water Temperature °F/°C |           |           |              |
|                                    | 50/10.0                 | 70/21.1   | 90/32.2   |              |
| 70/21.1                            | 10.6-12.5               | 12.0-14.1 | 12.3-14.4 | 1-2.5        |
| 80/26.7                            | 10.8-12.7               | 12.3-14.4 | 13.8-16.1 |              |
| 90/32.2                            | 11.0-13.0               | 12.6-14.7 | 14.1-16.5 |              |
| 100/37.8                           | 11.3-13.2               | 12.8-15.0 | 14.5-16.9 |              |
| Times in minutes                   |                         |           |           |              |

**24 Hour Ice Production**

| Air Temp. Around Ice Machine °F/°C  | Water Temperature °F/°C |         |         |
|---|-------------------------|---------|---------|
|   | 50/10.0                 | 70/21.1 | 90/32.2 |
| 70/21.1   | 290                     | 260     | 255     |
| 80/26.7   | 285                     | 255     | 230     |
| 90/32.2   | 280                     | 250     | 225     |
| 100/37.8  | 275                     | 245     | 220     |
| Based on average ice slab weight of 2.44 - 2.81 lb<br>Regular cube derate is 7% |                         |         |         |

| Condenser Water Consumption  | 90/32.2 Air Temperature Around Ice Machine |         |         |
|--|--|---------|---------|
|  | Water Temperature °F/°C                    |         |         |
|  | 50/10.0                                    | 70/21.1 | 90/32.2 |
| Gal/24 hours   | 250  | 490     | 3400    |
| Water regulating valve set to maintain 230 PSIG discharge pressure |  |         |         |

**Operating Pressures**

| Air Temp. Around Ice Machine °F/°C                           | Freeze Cycle            |                       | Harvest Cycle           |                       |
|--|-------------------------|-----------------------|-------------------------|-----------------------|
|  | Discharge Pressure PSIG | Suction Pressure PSIG | Discharge Pressure PSIG | Suction Pressure PSIG |
| 50/10.0  | 225-235                 | 60-28                 | 190-200                 | 75-90                 |
| 70/21.1  | 225-235                 | 60-28                 | 190-200                 | 80-90                 |
| 80/26.7  | 225-240                 | 60-28                 | 190-200                 | 80-90                 |
| 90/32.2  | 225-245                 | 62-28                 | 190-200                 | 80-90                 |
| 100/37.8   | 225-250                 | 62-30                 | 190-200                 | 80-90                 |
| 110/43.3   | 225-260                 | 64-32                 | 195-205                 | 80-95                 |
| Suction pressure drops gradually throughout the freeze cycle |                         |                       |                         |                       |

**Q320 SERIES**

**Self-Contained Air-Cooled**

NOTE: These characteristics may vary depending on operating conditions.

**Cycle Times**

Freeze Time + Harvest Time = Total Cycle Time

| Air Temp. Entering Condenser °F/°C | Freeze Time             |           |           | Harvest Time |
|------------------------------------|-------------------------|-----------|-----------|--------------|
|                                    | Water Temperature °F/°C |           |           |              |
|                                    | 50/10.0                 | 70/21.1   | 90/32.2   |              |
| 70/21.1                            | 12.2-13.9               | 13.1-14.9 | 14.2-16.2 | 1-2.5        |
| 80/26.7                            | 13.6-15.5               | 14.8-16.8 | 16.1-18.4 |              |
| 90/32.2                            | 16.1-18.4               | 17.7-20.2 | 19.7-22.3 |              |
| 100/37.8                           | 19.7-22.3               | 22.0-25.0 | 25.0-28.3 |              |
| Times in minutes                   |                         |           |           |              |

**24 Hour Ice Production**

| Air Temp. Entering Condenser °F/°C   | Water Temperature °F/°C |         |         |
|--|-------------------------|---------|---------|
|  | 50/10.0                 | 70/21.1 | 90/32.2 |
| 70/21.1  | 310                     | 290     | 270     |
| 80/26.7  | 280                     | 260     | 240     |
| 90/32.2  | 240                     | 220     | 200     |
| 100/37.8   | 200                     | 180     | 160     |
| Based on average ice slab weight of 2.94 - 3.31lb<br>Regular cube derate is 7% |                         |         |         |

**Operating Pressures**

| Air Temp. Entering Condenser °F/°C                           | Freeze Cycle            |                       | Harvest Cycle           |                       |
|--|-------------------------|-----------------------|-------------------------|-----------------------|
|  | Discharge Pressure PSIG | Suction Pressure PSIG | Discharge Pressure PSIG | Suction Pressure PSIG |
| 50/10.0  | 200-250                 | 50-36                 | 150-180                 | 75-90                 |
| 70/21.1  | 200-250                 | 50-36                 | 160-190                 | 80-100                |
| 80/26.7  | 220-280                 | 50-36                 | 170-200                 | 90-110                |
| 90/32.2  | 230-320                 | 54-38                 | 180-220                 | 90-120                |
| 100/37.8   | 270-360                 | 56-40                 | 200-250                 | 95-140                |
| 110/43.3   | 280-380                 | 58-42                 | 210-260                 | 95-150                |
| Suction pressure drops gradually throughout the freeze cycle |                         |                       |                         |                       |

**Q320 SERIES**

**Self-Contained Water-Cooled**

NOTE: These characteristics may vary depending on operating conditions.

**Cycle Times**

Freeze Time + Harvest Time = Total Cycle Time

| Air Temp. Around Ice Machine °F/°C | Freeze Time             |           |           | Harvest Time |
|------------------------------------|-------------------------|-----------|-----------|--------------|
|                                    | Water Temperature °F/°C |           |           |              |
|                                    | 50/10.0                 | 70/21.1   | 90/32.2   |              |
| 70/21.1                            | 12.6-14.4               | 13.6-15.5 | 15.4-17.6 | 1-2.5        |
| 80/26.7                            | 13.1-14.9               | 14.2-16.2 | 16.1-18.4 |              |
| 90/32.2                            | 13.6-15.5               | 14.8-16.8 | 16.9-19.2 |              |
| 100/37.8                           | 14.2-16.2               | 15.4-17.6 | 17.7-20.2 |              |
| Times in minutes                   |                         |           |           |              |

**24 Hour Ice Production**

| Air Temp. Around Ice Machine °F/°C  | Water Temperature °F/°C |         |         |
|---|-------------------------|---------|---------|
|   | 50/10.0                 | 70/21.1 | 90/32.2 |
| 70/21.1   | 300                     | 280     | 250     |
| 80/26.7   | 290                     | 270     | 240     |
| 90/32.2   | 280                     | 260     | 230     |
| 100/37.8  | 270                     | 250     | 220     |
| Based on average ice slab weight of 2.94 - 3.31 lb<br>Regular cube derate is 7% |                         |         |         |

| Condenser Water Consumption  | 90/32.2 Air Temperature Around Ice Machine |         |         |
|--|--|---------|---------|
|  | Water Temperature °F/°C                    |         |         |
|  | 50/10.0                                    | 70/21.1 | 90/32.2 |
| Gal/24 hours   | 270  | 560     | 3200    |
| Water regulating valve set to maintain 230 PSIG discharge pressure |  |         |         |

**Operating Pressures**

| Air Temp. Around Ice Machine °F/°C                           | Freeze Cycle            |                       | Harvest Cycle           |                       |
|--|-------------------------|-----------------------|-------------------------|-----------------------|
|  | Discharge Pressure PSIG | Suction Pressure PSIG | Discharge Pressure PSIG | Suction Pressure PSIG |
| 50/10.0  | 225-235                 | 50-36                 | 160-180                 | 80-110                |
| 70/21.1  | 225-235                 | 50-36                 | 170-190                 | 85-115                |
| 80/26.7  | 225-240                 | 50-36                 | 170-200                 | 85-115                |
| 90/32.2  | 225-250                 | 50-36                 | 170-210                 | 90-120                |
| 100/37.8   | 225-260                 | 52-36                 | 170-210                 | 90-120                |
| 110/43.3   | 225-265                 | 54-36                 | 175-215                 | 95-125                |
| Suction pressure drops gradually throughout the freeze cycle |                         |                       |                         |                       |

**Q370 SERIES**

**Self-Contained Air-Cooled**

NOTE: These characteristics may vary depending on operating conditions.

**Cycle Times**

Freeze Time + Harvest Time = Total Cycle Time

| Air Temp. Entering Condenser °F/°C | Freeze Time             |           |           | Harvest Time |
|------------------------------------|-------------------------|-----------|-----------|--------------|
|                                    | Water Temperature °F/°C |           |           |              |
|                                    | 50/10.0                 | 70/21.1   | 90/32.2   |              |
| 70/21.1                            | 10.3-11.7               | 11.7-13.4 | 12.6-14.4 | 1-2.5        |
| 80/26.7                            | 11.3-12.9               | 12.6-14.4 | 13.9-15.8 |              |
| 90/32.2                            | 12.9-14.7               | 13.9-15.8 | 15.4-17.6 |              |
| 100/37.8                           | 14.5-16.5               | 16.1-18.4 | 17.3-19.7 |              |
| Times in minutes                   |                         |           |           |              |

**24 Hour Ice Production**

| Air Temp. Entering Condenser °F/°C                | Water Temperature °F/°C |         |         |
|---|-------------------------|---------|---------|
|   | 50/10.0                 | 70/21.1 | 90/32.2 |
| 70/21.1   | 360                     | 320     | 300     |
| 80/26.7   | 330                     | 300     | 275     |
| 90/32.2   | 295                     | 275     | 250     |
| 100/37.8  | 265                     | 240     | 225     |
| Based on average ice slab weight of 2.94 - 3.31lb |                         |         |         |

**Operating Pressures**

| Air Temp. Entering Condenser °F/°C                           | Freeze Cycle            |                       | Harvest Cycle           |                       |
|--|-------------------------|-----------------------|-------------------------|-----------------------|
|  | Discharge Pressure PSIG | Suction Pressure PSIG | Discharge Pressure PSIG | Suction Pressure PSIG |
| 50/10.0  | 200-250                 | 60-34                 | 145-165                 | 75-95                 |
| 70/21.1  | 215-250                 | 60-36                 | 150-170                 | 85-100                |
| 80/26.7  | 250-290                 | 65-38                 | 165-185                 | 90-110                |
| 90/32.2  | 260-330                 | 70-40                 | 175-195                 | 100-120               |
| 100/37.8   | 300-380                 | 80-41                 | 195-220                 | 130-150               |
| 110/43.3   | 310-390                 | 80-42                 | 200-225                 | 135-155               |
| Suction pressure drops gradually throughout the freeze cycle |                         |                       |                         |                       |

**Q370 SERIES**

**Self-Contained Water-Cooled**

NOTE: These characteristics may vary depending on operating conditions.

**Cycle Times**

Freeze Time + Harvest Time = Total Cycle Time

| Air Temp. Around Ice Machine °F/°C | Freeze Time             |           |           | Harvest Time |
|------------------------------------|-------------------------|-----------|-----------|--------------|
|                                    | Water Temperature °F/°C |           |           |              |
|                                    | 50/10.0                 | 70/21.1   | 90/32.2   |              |
| 70/21.1                            | 10.3-11.7               | 11.0-12.5 | 12.2-13.9 | 1-2.5        |
| 80/26.7                            | 10.6-12.1               | 11.3-12.9 | 12.6-14.4 |              |
| 90/32.2                            | 11.0-12.5               | 11.7-13.4 | 13.1-14.4 |              |
| 100/37.8                           | 11.3-12.9               | 12.2-13.9 | 13.6-15.5 |              |
| Times in minutes                   |                         |           |           |              |

**24 Hour Ice Production**

| Air Temp. Around Ice Machine °F/°C                | Water Temperature °F/°C |         |         |
|---|-------------------------|---------|---------|
|   | 50/10.0                 | 70/21.1 | 90/32.2 |
| 70/21.1   | 360                     | 340     | 310     |
| 80/26.7   | 350                     | 330     | 300     |
| 90/32.2   | 340                     | 320     | 290     |
| 100/37.8  | 330                     | 310     | 280     |
| Based on average ice slab weight of 2.94 - 3.31lb |                         |         |         |

| Condenser Water Consumption  | 90/32.2 Air Temperature Around Ice Machine |         |         |
|--|--|---------|---------|
|  | Water Temperature °F/°C                    |         |         |
|  | 50/10.0                                    | 70/21.1 | 90/32.2 |
| Gal/24 hours   | 220  | 490     | 3700    |
| Water regulating valve set to maintain 230 PSIG discharge pressure |  |         |         |

**Operating Pressures**

| Air Temp. Around Ice Machine °F/°C                           | Freeze Cycle            |                       | Harvest Cycle           |                       |
|--|-------------------------|-----------------------|-------------------------|-----------------------|
|  | Discharge Pressure PSIG | Suction Pressure PSIG | Discharge Pressure PSIG | Suction Pressure PSIG |
| 50/10.0  | 225-235                 | 60-32                 | 150-170                 | 85-100                |
| 70/21.1  | 225-235                 | 60-33                 | 150-170                 | 85-105                |
| 80/26.7  | 225-240                 | 65-36                 | 155-175                 | 90-110                |
| 90/32.2  | 225-240                 | 68-38                 | 155-175                 | 90-110                |
| 100/37.8   | 235-260                 | 75-40                 | 175-200                 | 100-120               |
| 110/43.3   | 240-265                 | 85-40                 | 185-205                 | 105-125               |
| Suction pressure drops gradually throughout the freeze cycle |                         |                       |                         |                       |

**Q420/450 SERIES**

**Self-Contained Air-Cooled**

NOTE: These characteristics may vary depending on operating conditions.

**Cycle Times**

Freeze Time + Harvest Time = Total Cycle Time

| Air Temp. Entering Condenser °F/°C | Freeze Time             |           |           | Harvest Time |
|------------------------------------|-------------------------|-----------|-----------|--------------|
|                                    | Water Temperature °F/°C |           |           |              |
|                                    | 50/10.0                 | 70/21.1   | 90/32.2   |              |
| 70/21.1                            | 9.7-11.4                | 10.9-12.8 | 12.0-14.0 | 1-2.5        |
| 80/26.7                            | 10.9-12.8               | 12.3-14.4 | 13.3-15.6 |              |
| 90/32.2                            | 12.3-14.4               | 14.1-16.5 | 15.5-18.0 |              |
| 100/37.8                           | 14.5-17.0               | 16.5-19.2 | 18.3-21.3 |              |
| Times in minutes                   |                         |           |           |              |

**24 Hour Ice Production**

| Air Temp. Entering Condenser °F/°C   | Water Temperature °F/°C |         |         |
|--|-------------------------|---------|---------|
|  | 50/10.0                 | 70/21.1 | 90/32.2 |
| 70/21.1  | 530                     | 480     | 440     |
| 80/26.7  | 480                     | 430     | 400     |
| 90/32.2  | 430                     | 380     | 350     |
| 100/37.8   | 370                     | 330     | 300     |
| Based on average ice slab weight of 4.12 - 4.75lb<br>Regular cube derate is 7% |                         |         |         |

**Operating Pressures**

| Air Temp. Entering Condenser °F/°C                           | Freeze Cycle            |                       | Harvest Cycle           |                       |
|--|-------------------------|-----------------------|-------------------------|-----------------------|
|  | Discharge Pressure PSIG | Suction Pressure PSIG | Discharge Pressure PSIG | Suction Pressure PSIG |
| 50/10.0  | 195-260                 | 45-30                 | 150-170                 | 75-90                 |
| 70/21.1  | 200-260                 | 47-33                 | 165-180                 | 80-100                |
| 80/26.7  | 230-265                 | 50-35                 | 165-185                 | 80-100                |
| 90/32.2  | 260-290                 | 55-36                 | 190-210                 | 90-110                |
| 100/37.8   | 290-340                 | 60-38                 | 215-235                 | 105-125               |
| 110/43.3   | 195-260                 | 45-30                 | 235-255                 | 125-140               |
| Suction pressure drops gradually throughout the freeze cycle |                         |                       |                         |                       |

**Q420/450 SERIES**

**Self-Contained Water-Cooled**

NOTE: These characteristics may vary depending on operating conditions.

**Cycle Times**

Freeze Time + Harvest Time = Total Cycle Time

| Air Temp. Around Ice Machine °F/°C | Freeze Time             |           |           | Harvest Time |
|------------------------------------|-------------------------|-----------|-----------|--------------|
|                                    | Water Temperature °F/°C |           |           |              |
|                                    | 50/10.0                 | 70/21.1   | 90/32.2   |              |
| 70/21.1                            | 9.9-11.7                | 11.4-13.4 | 12.6-14.8 | 1-2.5        |
| 80/26.7                            | 10.1-11.9               | 11.7-13.7 | 13.0-15.2 |              |
| 90/32.2                            | 10.4-12.2               | 12.0-14.0 | 13.3-15.6 |              |
| 100/37.8                           | 10.6-12.5               | 12.3-14.4 | 13.7-16.0 |              |
| Times in minutes                   |                         |           |           |              |

**24 Hour Ice Production**

| Air Temp. Around Ice Machine °F/°C   | Water Temperature °F/°C |         |         |
|--|-------------------------|---------|---------|
|  | 50/10.0                 | 70/21.1 | 90/32.2 |
| 70/21.1  | 520                     | 460     | 420     |
| 80/26.7  | 510                     | 450     | 410     |
| 90/32.2  | 500                     | 440     | 400     |
| 100/37.8   | 490                     | 430     | 390     |
| Based on average ice slab weight of 4.12 - 4.75 lb.<br>Regular cube derate is 7% |                         |         |         |

| Condenser Water Consumption  | 90/32.2 Air Temperature Around Ice Machine |         |         |
|--|--|---------|---------|
|  | Water Temperature °F/°C                    |         |         |
|  | 50/10.0                                    | 70/21.1 | 90/32.2 |
| Gal/24 hours   | 400  | 740     | 2400    |
| Water regulating valve set to maintain 230 PSIG discharge pressure |  |         |         |

**Operating Pressures**

| Air Temp. Around Ice Machine °F/°C                           | Freeze Cycle            |                       | Harvest Cycle           |                       |
|--|-------------------------|-----------------------|-------------------------|-----------------------|
|  | Discharge Pressure PSIG | Suction Pressure PSIG | Discharge Pressure PSIG | Suction Pressure PSIG |
| 50/10.0  | 235-245                 | 50-35                 | 165-180                 | 85-100                |
| 70/21.1  | 235-245                 | 50-35                 | 165-180                 | 85-100                |
| 80/26.7  | 235-245                 | 50-35                 | 165-180                 | 85-100                |
| 90/32.2  | 235-245                 | 52-35                 | 165-180                 | 85-100                |
| 100/37.8   | 235-245                 | 52-35                 | 165-185                 | 85-100                |
| 110/43.3   | 240-250                 | 55-36                 | 165-185                 | 85-100                |
| Suction pressure drops gradually throughout the freeze cycle |                         |                       |                         |                       |



**Q450 SERIES**

**Remote**

NOTE: These characteristics may vary depending on operating conditions.

**Cycle Times**

Freeze Time + Harvest Time = Total Cycle Time

| Air Temp. Entering Condenser °F/°C | Freeze Time             |           |           | Harvest Time |
|------------------------------------|-------------------------|-----------|-----------|--------------|
|                                    | Water Temperature °F/°C |           |           |              |
|                                    | 50/10.0                 | 70/21.1   | 90/32.2   |              |
| -20/-28.9 to 70/21.1               | 10.6-12.5               | 12.0-14.0 | 13.3-15.6 | 1-2.5        |
| 80/26.7                            | 10.9-12.8               | 12.3-14.4 | 13.7-16.0 |              |
| 90/32.2                            | 11.1-13.1               | 12.6-14.8 | 14.1-16.5 |              |
| 100/37.8                           | 12.0-14.0               | 13.7-16.0 | 15.5-18.0 |              |
| 110/43.3                           | 13.3-15.6               | 15.5-18.0 | 17.6-20.6 |              |
| Times in minutes                   |                         |           |           |              |

**24 Hour Ice Production**

| Air Temp. Entering Condenser °F/°C  | Water Temperature °F/°C |         |         |
|---|-------------------------|---------|---------|
|   | 50/10.0                 | 70/21.1 | 90/32.2 |
| -20/-28.9 to 70/21.1  | 490                     | 440     | 400     |
| 80/26.7   | 480                     | 430     | 390     |
| 90/32.2   | 470                     | 420     | 380     |
| 100/37.8  | 440                     | 390     | 350     |
| 110/43.3  | 400                     | 350     | 310     |
| Based on average ice slab weight of 4.12- 4.75lb<br>Regular cube derate is 7%<br>Ratings with JC0495 condenser, dice or half dice cubes |                         |         |         |

**Operating Pressures**

| Air Temp. Entering Condenser °F/°C                           | Freeze Cycle            |                       | Harvest Cycle           |                       |
|--|-------------------------|-----------------------|-------------------------|-----------------------|
|  | Discharge Pressure PSIG | Suction Pressure PSIG | Discharge Pressure PSIG | Suction Pressure PSIG |
| -20/-28.9 to 50/10.0   | 225-245                 | 50-32                 | 175-190                 | 85-100                |
| 70/21.1  | 230-250                 | 50-32                 | 175-190                 | 85-100                |
| 80/26.7  | 240-260                 | 52-32                 | 180-195                 | 85-100                |
| 90/32.2  | 245-270                 | 54-35                 | 185-200                 | 85-100                |
| 100/37.8   | 280-310                 | 57-37                 | 190-205                 | 90-105                |
| 110/43.3   | 290-325                 | 64-39                 | 190-205                 | 95-110                |
| Suction pressure drops gradually throughout the freeze cycle |                         |                       |                         |                       |

**Q600 SERIES**

**Self-Contained Air-Cooled**

NOTE: These characteristics may vary depending on operating conditions.

**Cycle Times**

Freeze Time + Harvest Time = Total Cycle Time

| Air Temp. Entering Condenser °F/°C | Freeze Time             |           |           | Harvest Time |
|------------------------------------|-------------------------|-----------|-----------|--------------|
|                                    | Water Temperature °F/°C |           |           |              |
|                                    | 50/10.0                 | 70/21.1   | 90/32.2   |              |
| 70/21.1                            | 7.1-8.4                 | 7.8-9.2   | 8.6-10.1  | 1-2.5        |
| 80/26.7                            | 7.8-9.2                 | 8.6-10.1  | 9.5-11.2  |              |
| 90/32.2                            | 8.6-10.1                | 9.5-11.2  | 10.4-12.2 |              |
| 100/37.8                           | 9.5-11.2                | 10.6-12.5 | 12.0-14.0 |              |
| Times in minutes                   |                         |           |           |              |

**24 Hour Ice Production**

| Air Temp. Entering Condenser °F/°C  | Water Temperature °F/°C |         |         |
|---|-------------------------|---------|---------|
|   | 50/10.0                 | 70/21.1 | 90/32.2 |
| 70/21.1   | 690                     | 640     | 590     |
| 80/26.7   | 640                     | 590     | 540     |
| 90/32.2   | 590                     | 540     | 500     |
| 100/37.8  | 540                     | 490     | 440     |
| Based on average ice slab weight of 4.12- 4.75lb<br>Regular cube derate is 7% |                         |         |         |

**Operating Pressures**

| Air Temp. Entering Condenser °F/°C                           | Freeze Cycle            |                       | Harvest Cycle           |                       |
|--|-------------------------|-----------------------|-------------------------|-----------------------|
|  | Discharge Pressure PSIG | Suction Pressure PSIG | Discharge Pressure PSIG | Suction Pressure PSIG |
| 50/10.0  | 195-260                 | 42-22                 | 155-180                 | 75-95                 |
| 70/21.1  | 220-290                 | 44-22                 | 160-185                 | 85-100                |
| 80/26.7  | 220-305                 | 52-22                 | 160-190                 | 90-110                |
| 90/32.2  | 250-325                 | 52-23                 | 175-195                 | 95-115                |
| 100/37.8   | 280-355                 | 54-30                 | 195-210                 | 95-125                |
| 110/43.3   | 300-385                 | 56-32                 | 200-225                 | 100-135               |
| Suction pressure drops gradually throughout the freeze cycle |                         |                       |                         |                       |

**Q600 SERIES**

**Self-Contained Water-Cooled**

NOTE: These characteristics may vary depending on operating conditions.

**Cycle Times**

Freeze Time + Harvest Time = Total Cycle Time

| Air Temp. Around Ice Machine °F/°C | Freeze Time             |          |           | Harvest Time |
|------------------------------------|-------------------------|----------|-----------|--------------|
|                                    | Water Temperature °F/°C |          |           |              |
|                                    | 50/10.0                 | 70/21.1  | 90/32.2   |              |
| 70/21.1                            | 7.4-8.7                 | 8.2-9.7  | 9.5-11.2  | 1-2.5        |
| 80/26.7                            | 7.5-8.9                 | 8.4-9.9  | 9.7-11.4  |              |
| 90/32.2                            | 7.8-9.2                 | 8.7-10.3 | 9.9-11.7  |              |
| 100/37.8                           | 7.9-9.4                 | 8.9-10.5 | 10.1-11.9 |              |

Times in minutes

**24 Hour Ice Production**

| Air Temp. Around Ice Machine °F/°C | Water Temperature °F/°C |         |         |
|------------------------------------|-------------------------|---------|---------|
|                                    | 50/10.0                 | 70/21.1 | 90/32.2 |
| 70/21.1                            | 670                     | 610     | 540     |
| 80/26.7                            | 660                     | 600     | 530     |
| 90/32.2                            | 640                     | 580     | 520     |
| 100/37.8                           | 630                     | 570     | 510     |

Based on average ice slab weight of 4.12 - 4.75 lb  
Regular cube derate is 7%

| Condenser Water Consumption | 90/32.2 Air Temperature Around Ice Machine |         |         |
|-----------------------------|--|---------|---------|
|                             | Water Temperature °F/°C                    |         |         |
|                             | 50/10.0                                    | 70/21.1 | 90/32.2 |
| Gal/24 hours                | 600  | 1250    | 6800    |

Water regulating valve set to maintain 230 PSIG discharge pressure

**Operating Pressures**

| Air Temp. Around Ice Machine °F/°C | Freeze Cycle            |                       | Harvest Cycle           |                       |
|------------------------------------|-------------------------|-----------------------|-------------------------|-----------------------|
|                                    | Discharge Pressure PSIG | Suction Pressure PSIG | Discharge Pressure PSIG | Suction Pressure PSIG |
| 50/10.0                            | 225-235                 | 46-25                 | 140-184                 | 80-102                |
| 70/21.1                            | 225-235                 | 46-26                 | 148-184                 | 82-104                |
| 80/26.7                            | 225-235                 | 48-26                 | 154-186                 | 86-108                |
| 90/32.2                            | 225-240                 | 48-26                 | 154-190                 | 86-108                |
| 100/37.8                           | 225-245                 | 50-28                 | 162-194                 | 86-112                |
| 110/43.3                           | 225-250                 | 52-28                 | 165-200                 | 86-115                |

Suction pressure drops gradually throughout the freeze cycle

**Q600 SERIES**

**Remote**

NOTE: These characteristics may vary depending on operating conditions.

**Cycle Times**

Freeze Time + Harvest Time = Total Cycle Time

| Air Temp. Entering Condenser °F/°C | Freeze Time             |           |           | Harvest Time |
|------------------------------------|-------------------------|-----------|-----------|--------------|
|                                    | Water Temperature °F/°C |           |           |              |
|                                    | 50/10.0                 | 70/21.1   | 90/32.2   |              |
| -20/-28.9 to 70/21.1               | 7.9-9.4                 | 8.9-10.5  | 9.5-11.2  | 1-2.5        |
| 80/26.7                            | 8.0-9.4                 | 9.0-10.6  | 9.6-11.3  |              |
| 90/32.2                            | 8.1-9.5                 | 9.1-10.7  | 9.7-11.4  |              |
| 100/37.8                           | 8.4-9.9                 | 9.5-11.2  | 10.1-11.9 |              |
| 110/43.3                           | 8.9-10.5                | 10.1-11.9 | 10.9-12.8 |              |

Times in minutes

**24 Hour Ice Production**

| Air Temp. Entering Condenser °F/°C | Water Temperature °F/°C |         |         |
|------------------------------------|-------------------------|---------|---------|
|                                    | 50/10.0                 | 70/21.1 | 90/32.2 |
| -20/-28.9 to 70/21.1               | 630                     | 570     | 540     |
| 80/26.7                            | 625                     | 565     | 535     |
| 90/32.2                            | 620                     | 560     | 530     |
| 100/37.8                           | 600                     | 540     | 510     |
| 110/43.3                           | 570                     | 510     | 480     |

Based on average ice slab weight of 4.12- 4.75 lb  
Regular cube derate is 7%  
Ratings with JC0895 condenser, dice or half dice cubes

**Operating Pressures**

| Air Temp. Entering Condenser °F/°C | Freeze Cycle            |                       | Harvest Cycle           |                       |
|------------------------------------|-------------------------|-----------------------|-------------------------|-----------------------|
|                                    | Discharge Pressure PSIG | Suction Pressure PSIG | Discharge Pressure PSIG | Suction Pressure PSIG |
| -20/-28.9 to 50/10.0               | 220-250                 | 42-26                 | 152-170                 | 75-100                |
| 70/21.1                            | 225-260                 | 44-26                 | 155-172                 | 82-100                |
| 80/26.7                            | 245-265                 | 46-26                 | 156-174                 | 82-100                |
| 90/32.2                            | 250-265                 | 48-26                 | 157-174                 | 84-100                |
| 100/37.8                           | 265-295                 | 52-26                 | 158-176                 | 84-100                |
| 110/43.3                           | 300-335                 | 52-28                 | 158-176                 | 84-105                |

Suction pressure drops gradually throughout the freeze cycle

**Q800 SERIES**

**Self-Contained Air-Cooled**

NOTE: These characteristics may vary depending on operating conditions.

**Cycle Times**

Freeze Time + Harvest Time = Total Cycle Time

| Air Temp. Entering Condenser °F/°C | Freeze Time             |           |           | Harvest Time |
|------------------------------------|-------------------------|-----------|-----------|--------------|
|                                    | Water Temperature °F/°C |           |           |              |
|                                    | 50/10.0                 | 70/21.1   | 90/32.2   |              |
| 70/21.1                            | 8.9-10.2                | 9.7-11.1  | 10.3-11.9 | 1-2.5        |
| 80/26.7                            | 9.3-10.7                | 10.2-11.7 | 10.9-12.5 |              |
| 90/32.2                            | 10.3-11.9               | 11.4-13.1 | 12.3-14.1 |              |
| 100/37.8                           | 12.1-13.8               | 13.3-15.2 | 14.4-16.5 |              |

Times in minutes

**24 Hour Ice Production**

| Air Temp. Entering Condenser °F/°C | Water Temperature °F/°C |         |         |
|------------------------------------|-------------------------|---------|---------|
|                                    | 50/10.0                 | 70/21.1 | 90/32.2 |
| 70/21.1                            | 800                     | 740     | 700     |
| 80/26.7                            | 770                     | 710     | 670     |
| 90/32.2                            | 700                     | 640     | 600     |
| 100/37.8                           | 610                     | 560     | 520     |

Based on average ice slab weight of 5.75- 6.50 lb  
Regular cube derate is 7%

**Operating Pressures**

| Air Temp. Entering Condenser °F/°C | Freeze Cycle            |                       | Harvest Cycle           |                       |
|------------------------------------|-------------------------|-----------------------|-------------------------|-----------------------|
|                                    | Discharge Pressure PSIG | Suction Pressure PSIG | Discharge Pressure PSIG | Suction Pressure PSIG |
| 50/10.0                            | 220-280                 | 31-18                 | 135-180                 | 65-90                 |
| 70/21.1                            | 220-280                 | 32-18                 | 140-180                 | 70-90                 |
| 80/26.7                            | 225-280                 | 36-20                 | 140-180                 | 70-95                 |
| 90/32.2                            | 260-295                 | 38-22                 | 150-200                 | 80-100                |
| 100/37.8                           | 300-330                 | 40-24                 | 210-225                 | 80-100                |
| 110/43.3                           | 320-360                 | 44-26                 | 210-240                 | 85-120                |

Suction pressure drops gradually throughout the freeze cycle

**Q800 SERIES**

**Self-Contained Water-Cooled**

NOTE: These characteristics may vary depending on operating conditions.

**Cycle Times**

Freeze Time + Harvest Time = Total Cycle Time

| Air Temp. Around Ice Machine °F/°C | Freeze Time             |           |           | Harvest Time |
|------------------------------------|-------------------------|-----------|-----------|--------------|
|                                    | Water Temperature °F/°C |           |           |              |
|                                    | 50/10.0                 | 70/21.1   | 90/32.2   |              |
| 70/21.1                            | 8.7-10.1                | 9.5-11.0  | 10.9-12.5 | 1-2.5        |
| 80/26.7                            | 8.9-10.2                | 9.7-11.1  | 11.0-12.7 |              |
| 90/32.2                            | 9.0-10.3                | 9.8-11.3  | 11.2-12.9 |              |
| 100/37.8                           | 9.1-10.5                | 10.0-11.5 | 11.4-13.1 |              |

Times in minutes

**24 Hour Ice Production**

| Air Temp. Around Ice Machine °F/°C | Water Temperature °F/°C |         |         |
|------------------------------------|-------------------------|---------|---------|
|                                    | 50/10.0                 | 70/21.1 | 90/32.2 |
| 70/21.1                            | 810                     | 750     | 670     |
| 80/26.7                            | 800                     | 740     | 660     |
| 90/32.2                            | 790                     | 730     | 650     |
| 100/37.8                           | 780                     | 720     | 640     |

Based on average ice slab weight of 5.75- 6.50lb  
Regular cube derate is 7%

| Condenser Water Consumption | 90/32.2 Air Temperature Around Ice Machine |         |         |
|-----------------------------|--|---------|---------|
|                             | Water Temperature °F/°C                    |         |         |
|                             | 50/10.0                                    | 70/21.1 | 90/32.2 |
| Gal/24 hours                | 640  | 1420    | 6000    |

Water regulating valve set to maintain 230 PSIG discharge pressure

**Operating Pressures**

| Air Temp. Around Ice Machine °F/°C | Freeze Cycle            |                       | Harvest Cycle           |                       |
|------------------------------------|-------------------------|-----------------------|-------------------------|-----------------------|
|                                    | Discharge Pressure PSIG | Suction Pressure PSIG | Discharge Pressure PSIG | Suction Pressure PSIG |
| 50/10.0                            | 225-235                 | 33-20                 | 160-185                 | 65-85                 |
| 70/21.1                            | 225-235                 | 34-20                 | 165-185                 | 70-85                 |
| 80/26.7                            | 225-235                 | 34-20                 | 165-185                 | 70-85                 |
| 90/32.2                            | 225-235                 | 36-22                 | 165-185                 | 70-85                 |
| 100/37.8                           | 225-235                 | 36-22                 | 165-185                 | 70-85                 |
| 110/43.3                           | 225-240                 | 38-24                 | 170-190                 | 75-90                 |

Suction pressure drops gradually throughout the freeze cycle

**Q800 SERIES**

**Remote**

NOTE: These characteristics may vary depending on operating conditions.

**Cycle Times**

Freeze Time + Harvest Time = Total Cycle Time

| Air Temp. Entering Condenser °F/°C | Freeze Time             |           |           | Harvest Time |
|------------------------------------|-------------------------|-----------|-----------|--------------|
|                                    | Water Temperature °F/°C |           |           |              |
|                                    | 50/10.0                 | 70/21.1   | 90/32.2   |              |
| -20/-28.9 to 70/21.1               | 9.5-11.0                | 10.6-12.2 | 11.6-13.4 | 1-2.5        |
| 80/26.7                            | 9.7-11.1                | 10.8-12.4 | 11.9-13.6 |              |
| 90/32.2                            | 9.8-11.3                | 11.0-12.6 | 12.1-13.8 |              |
| 100/37.8                           | 10.6-12.2               | 11.9-13.6 | 13.2-15.1 |              |
| 110/43.3                           | 11.9-13.6               | 13.4-15.4 | 14.7-16.9 |              |
| Times in minutes                   |                         |           |           |              |

**24 Hour Ice Production**

| Air Temp. Entering Condenser °F/°C  | Water Temperature °F/°C |         |         |
|---|-------------------------|---------|---------|
|   | 50/10.0                 | 70/21.1 | 90/32.2 |
| -20/-28.9 to 70/21.1  | 750                     | 685     | 630     |
| 80/26.7   | 740                     | 675     | 620     |
| 90/32.2   | 730                     | 665     | 610     |
| 100/37.8  | 685                     | 620     | 565     |
| 110/43.3  | 620                     | 555     | 510     |
| Based on average ice slab weight of 5.75- 6.50lb<br>Regular cube derate is 7%<br>Ratings with JC0895 condenser, dice or half dice cubes |                         |         |         |

**Operating Pressures**

| Air Temp. Entering Condenser °F/°C                           | Freeze Cycle            |                       | Harvest Cycle           |                       |
|--|-------------------------|-----------------------|-------------------------|-----------------------|
|  | Discharge Pressure PSIG | Suction Pressure PSIG | Discharge Pressure PSIG | Suction Pressure PSIG |
| -20/-28.9 to 50/10.0   | 220-250                 | 30-22                 | 180-200                 | 65-90                 |
| 70/21.1  | 225-250                 | 32-22                 | 190-200                 | 70-90                 |
| 80/26.7  | 240-260                 | 33-22                 | 190-205                 | 70-90                 |
| 90/32.2  | 255-265                 | 34-22                 | 195-205                 | 70-90                 |
| 100/37.8   | 275-295                 | 38-24                 | 200-210                 | 70-90                 |
| 110/43.3   | 280-320                 | 40-26                 | 200-225                 | 75-100                |
| Suction pressure drops gradually throughout the freeze cycle |                         |                       |                         |                       |

**Q1000 SERIES**

**Self-Contained Air-Cooled**

NOTE: These characteristics may vary depending on operating conditions.

**Cycle Times**

Freeze Time + Harvest Time = Total Cycle Time

| Air Temp. Entering Condenser °F/°C | Freeze Time             |           |           | Harvest Time |
|------------------------------------|-------------------------|-----------|-----------|--------------|
|                                    | Water Temperature °F/°C |           |           |              |
|                                    | 50/10.0                 | 70/21.1   | 90/32.2   |              |
| 70/21.1                            | 9.9-10.6                | 10.6-11.4 | 11.3-12.2 | 1-2.5        |
| 80/26.7                            | 10.2-11.0               | 11.2-12.0 | 11.9-12.8 |              |
| 90/32.2                            | 10.9-11.7               | 11.9-12.8 | 12.8-13.7 |              |
| 100/37.8                           | 12.1-13.0               | 13.2-14.1 | 14.2-15.2 |              |
| Times in minutes                   |                         |           |           |              |

**24 Hour Ice Production**

| Air Temp. Entering Condenser °F/°C   | Water Temperature °F/°C |         |         |
|--|-------------------------|---------|---------|
|  | 50/10.0                 | 70/21.1 | 90/32.2 |
| 70/21.1  | 980                     | 920     | 870     |
| 80/26.7  | 950                     | 880     | 830     |
| 90/32.2  | 900                     | 830     | 780     |
| 100/37.8   | 820                     | 760     | 710     |
| Based on average ice slab weight of 7.75 - 8.25lb<br>Regular cube derate is 7% |                         |         |         |

**Operating Pressures**

| Air Temp. Entering Condenser °F/°C                           | Freeze Cycle            |                       | Harvest Cycle           |                       |
|--|-------------------------|-----------------------|-------------------------|-----------------------|
|  | Discharge Pressure PSIG | Suction Pressure PSIG | Discharge Pressure PSIG | Suction Pressure PSIG |
| 50/10.0  | 220-280                 | 38-18                 | 135-180                 | 65-90                 |
| 70/21.1  | 220-280                 | 40-18                 | 140-180                 | 70-90                 |
| 80/26.7  | 225-280                 | 42-20                 | 140-180                 | 70-95                 |
| 90/32.2  | 260-295                 | 42-22                 | 150-200                 | 80-100                |
| 100/37.8   | 300-330                 | 42-24                 | 210-225                 | 80-100                |
| 110/43.3   | 320-360                 | 44-24                 | 210-240                 | 85-120                |
| Suction pressure drops gradually throughout the freeze cycle |                         |                       |                         |                       |

**Q1000 SERIES**

**Self-Contained Water-Cooled**

NOTE: These characteristics may vary depending on operating conditions.

**Cycle Times**

Freeze Time + Harvest Time = Total Cycle Time

| Air Temp. Around Ice Machine °F/°C | Freeze Time             |           |           | Harvest Time |
|------------------------------------|-------------------------|-----------|-----------|--------------|
|                                    | Water Temperature °F/°C |           |           |              |
|                                    | 50/10.0                 | 70/21.1   | 90/32.2   |              |
| 70/21.1                            | 10.0-10.7               | 10.6-11.4 | 12.1-13.0 | 1-2.5        |
| 80/26.7                            | 10.1-10.9               | 10.8-11.6 | 12.3-13.2 |              |
| 90/32.2                            | 10.2-11.0               | 10.9-11.7 | 12.5-14.3 |              |
| 100/37.8                           | 10.4-11.1               | 11.0-11.8 | 12.6-14.4 |              |

Times in minutes

**24 Hour Ice Production**

| Air Temp. Around Ice Machine °F/°C | Water Temperature °F/°C |         |         |
|------------------------------------|-------------------------|---------|---------|
|                                    | 50/10.0                 | 70/21.1 | 90/32.2 |
| 70/21.1                            | 970                     | 920     | 820     |
| 80/26.7                            | 960                     | 910     | 810     |
| 90/32.2                            | 950                     | 900     | 800     |
| 100/37.8                           | 940                     | 890     | 790     |

Based on average ice slab weight of 7.75- 8.25lb  
Regular cube derate is 7%

| Condenser Water Consumption | 90/32.2 Air Temperature Around Ice Machine |         |         |
|-----------------------------|--|---------|---------|
|                             | Water Temperature °F/°C                    |         |         |
|                             | 50/10.0                                    | 70/21.1 | 90/32.2 |
| Gal/24 hours                | 750  | 1500    | 6200    |

Water regulating valve set to maintain 230 PSIG discharge pressure

**Operating Pressures**

| Air Temp. Around Ice Machine °F/°C | Freeze Cycle            |                       | Harvest Cycle           |                       |
|------------------------------------|-------------------------|-----------------------|-------------------------|-----------------------|
|                                    | Discharge Pressure PSIG | Suction Pressure PSIG | Discharge Pressure PSIG | Suction Pressure PSIG |
| 50/10.0                            | 225-235                 | 36-18                 | 160-185                 | 65-85                 |
| 70/21.1                            | 225-235                 | 38-18                 | 165-185                 | 70-85                 |
| 80/26.7                            | 225-235                 | 40-18                 | 165-185                 | 70-85                 |
| 90/32.2                            | 225-235                 | 40-20                 | 165-185                 | 70-85                 |
| 100/37.8                           | 225-235                 | 40-20                 | 165-185                 | 70-85                 |
| 110/43.3                           | 225-240                 | 42-20                 | 170-190                 | 75-90                 |

Suction pressure drops gradually throughout the freeze cycle

**Q1000 SERIES**

**Remote**

NOTE: These characteristics may vary depending on operating conditions.

**Cycle Times**

Freeze Time + Harvest Time = Total Cycle Time

| Air Temp. Entering Condenser °F/°C | Freeze Time             |           |           | Harvest Time |
|------------------------------------|-------------------------|-----------|-----------|--------------|
|                                    | Water Temperature °F/°C |           |           |              |
|                                    | 50/10.0                 | 70/21.1   | 90/32.2   |              |
| -20/-28.9 to 70/21.1               | 10.5-11.3               | 11.3-12.2 | 12.1-13.0 | 1-2.5        |
| 80/26.7                            | 10.7-11.5               | 11.5-12.3 | 12.3-13.2 |              |
| 90/32.2                            | 10.8-11.6               | 11.6-12.5 | 12.5-13.4 |              |
| 100/37.8                           | 11.5-12.3               | 12.5-13.4 | 13.4-14.3 |              |
| 110/43.3                           | 12.3-13.2               | 13.4-14.3 | 14.4-15.5 |              |

Times in minutes

**24 Hour Ice Production**

| Air Temp. Entering Condenser °F/°C | Water Temperature °F/°C |         |         |
|------------------------------------|-------------------------|---------|---------|
|                                    | 50/10.0                 | 70/21.1 | 90/32.2 |
| -20/-28.9 to 70/21.1               | 930                     | 870     | 820     |
| 80/26.7                            | 915                     | 860     | 810     |
| 90/32.2                            | 906                     | 850     | 800     |
| 100/37.8                           | 860                     | 800     | 750     |
| 110/43.3                           | 810                     | 750     | 700     |

Based on average ice slab weight of 7.75- 8.25lb  
Regular cube derate is 7%  
Ratings with JC1095 condenser, dice or half dice cubes

**Operating Pressures**

| Air Temp. Entering Condenser °F/°C | Freeze Cycle            |                       | Harvest Cycle           |                       |
|------------------------------------|-------------------------|-----------------------|-------------------------|-----------------------|
|                                    | Discharge Pressure PSIG | Suction Pressure PSIG | Discharge Pressure PSIG | Suction Pressure PSIG |
| -20/-28.9 to 50/10.0               | 220-250                 | 40-22                 | 180-200                 | 65-90                 |
| 70/21.1                            | 225-250                 | 40-22                 | 190-200                 | 70-90                 |
| 80/26.7                            | 240-260                 | 42-22                 | 190-205                 | 70-90                 |
| 90/32.2                            | 255-265                 | 44-22                 | 195-205                 | 70-90                 |
| 100/37.8                           | 275-295                 | 44-24                 | 200-210                 | 70-90                 |
| 110/43.3                           | 280-320                 | 46-26                 | 200-225                 | 75-100                |

Suction pressure drops gradually throughout the freeze cycle

**Q1300 SERIES**

**Self-Contained Air-Cooled**

NOTE: These characteristics may vary depending on operating conditions.

**Cycle Times**

Freeze Time + Harvest Time = Total Cycle Time

| Air Temp. Entering Condenser °F/°C | Freeze Time             |           |           | Harvest Time |
|------------------------------------|-------------------------|-----------|-----------|--------------|
|                                    | Water Temperature °F/°C |           |           |              |
|                                    | 50/10.0                 | 70/21.1   | 90/32.2   |              |
| 70/21.1                            | 9.4-10.5                | 9.9-11.1  | 10.9-12.2 | 1-2.5        |
| 80/26.7                            | 9.9-11.1                | 10.6-11.8 | 11.6-12.9 |              |
| 90/32.2                            | 11.0-12.3               | 11.5-12.8 | 12.8-14.2 |              |
| 100/37.8                           | 12.3-13.7               | 13.2-14.7 | 14.7-16.3 |              |
| Times in minutes                   |                         |           |           |              |

**24 Hour Ice Production**

| Air Temp. Entering Condenser °F/°C   | Water Temperature °F/°C |         |         |
|--|-------------------------|---------|---------|
|  | 50/10.0                 | 70/21.1 | 90/32.2 |
| 70/21.1  | 1320                    | 1260    | 1160    |
| 80/26.7  | 1260                    | 1190    | 1100    |
| 90/32.2  | 1150                    | 1110    | 1010    |
| 100/37.8   | 1040                    | 980     | 890     |
| Based on average ice slab weight of 10.0- 11.0 lb<br>Regular cube derate is 7% |                         |         |         |

**Operating Pressures**

| Air Temp. Entering Condenser °F/°C                           | Freeze Cycle            |                       | Harvest Cycle           |                       |
|--|-------------------------|-----------------------|-------------------------|-----------------------|
|  | Discharge Pressure PSIG | Suction Pressure PSIG | Discharge Pressure PSIG | Suction Pressure PSIG |
| 50/10.0  | 220-280                 | 40-20                 | 140-170                 | 65-80                 |
| 70/21.1  | 220-280                 | 40-20                 | 145-170                 | 70-80                 |
| 80/26.7  | 220-280                 | 42-22                 | 150-185                 | 70-80                 |
| 90/32.2  | 245-300                 | 48-26                 | 160-190                 | 70-85                 |
| 100/37.8   | 275-330                 | 50-26                 | 160-210                 | 70-90                 |
| 110/43.3   | 280-360                 | 52-28                 | 165-225                 | 75-100                |
| Suction pressure drops gradually throughout the freeze cycle |                         |                       |                         |                       |

**Q1300 SERIES**

**Self-Contained Water-Cooled**

NOTE: These characteristics may vary depending on operating conditions.

**Cycle Times**

Freeze Time + Harvest Time = Total Cycle Time

| Air Temp. Around Ice Machine °F/°C | Freeze Time             |           |           | Harvest Time |
|------------------------------------|-------------------------|-----------|-----------|--------------|
|                                    | Water Temperature °F/°C |           |           |              |
|                                    | 50/10.0                 | 70/21.1   | 90/32.2   |              |
| 70/21.1                            | 9.0-10.1                | 9.8-10.9  | 11.4-12.6 | 1-2.5        |
| 80/26.7                            | 9.1-10.1                | 9.8-11.0  | 11.6-12.9 |              |
| 90/32.2                            | 9.2-10.3                | 10.0-11.2 | 12.0-13.3 |              |
| 100/37.8                           | 9.4-10.5                | 10.1-11.3 | 12.2-13.6 |              |
| Times in minutes                   |                         |           |           |              |

**24 Hour Ice Production**

| Air Temp. Around Ice Machine °F/°C  | Water Temperature °F/°C |         |         |
|---|-------------------------|---------|---------|
|   | 50/10.0                 | 70/21.1 | 90/32.2 |
| 70/21.1   | 1370                    | 1280    | 1120    |
| 80/26.7   | 1360                    | 1270    | 1100    |
| 90/32.2   | 1340                    | 1250    | 1070    |
| 100/37.8  | 1320                    | 1240    | 1050    |
| Based on average ice slab weight of 10.0 - 11.0 lb<br>Regular cube derate is 7% |                         |         |         |

| Condenser Water Consumption  | 90/32.2 Air Temperature Around Ice Machine |         |         |
|--|--|---------|---------|
|  | Water Temperature °F/°C                    |         |         |
|  | 50/10.0                                    | 70/21.1 | 90/32.2 |
| Gal/24 hours   | 1150                                       | 2220    | 7400    |
| Water regulating valve set to maintain 240 PSIG discharge pressure |  |         |         |

**Operating Pressures**

| Air Temp. Around Ice Machine °F/°C                           | Freeze Cycle            |                       | Harvest Cycle           |                       |
|--|-------------------------|-----------------------|-------------------------|-----------------------|
|  | Discharge Pressure PSIG | Suction Pressure PSIG | Discharge Pressure PSIG | Suction Pressure PSIG |
| 50/10.0  | 235-245                 | 40-18                 | 150-180                 | 70-80                 |
| 70/21.1  | 235-245                 | 40-18                 | 150-180                 | 70-80                 |
| 80/26.7  | 235-245                 | 40-20                 | 150-180                 | 70-80                 |
| 90/32.2  | 235-250                 | 42-20                 | 150-180                 | 70-80                 |
| 100/37.8   | 235-255                 | 44-20                 | 150-180                 | 70-80                 |
| 110/43.3   | 240-265                 | 46-20                 | 150-180                 | 70-80                 |
| Suction pressure drops gradually throughout the freeze cycle |                         |                       |                         |                       |

**Q1300 SERIES**

**Remote**

NOTE: These characteristics may vary depending on operating conditions.

**Cycle Times**

Freeze Time + Harvest Time = Total Cycle Time

| Air Temp. Entering Condenser °F/°C | Freeze Time             |           |           | Harvest Time |
|------------------------------------|-------------------------|-----------|-----------|--------------|
|                                    | Water Temperature °F/°C |           |           |              |
|                                    | 50/10.0                 | 70/21.1   | 90/32.2   |              |
| -20/-28.9 to 70/21.1               | 9.9-11.1                | 10.9-12.2 | 11.7-13.0 | 1-2.5        |
| 80/26.7                            | 10.0-11.2               | 11.0-12.3 | 11.1-12.4 |              |
| 90/32.2                            | 10.1-11.3               | 11.1-12.4 | 10.7-11.9 |              |
| 100/37.8                           | 10.8-12.0               | 11.8-13.2 | 12.8-14.2 |              |
| 110/43.3                           | 11.7-13.0               | 12.9-14.3 | 13.8-15.4 |              |
| Times in minutes                   |                         |           |           |              |

**24 Hour Ice Production**

| Air Temp. Entering Condenser °F/°C  | Water Temperature °F/°C |         |         |
|---|-------------------------|---------|---------|
|   | 50/10.0                 | 70/21.1 | 90/32.2 |
| -20/-28.9 to 70/21.1  | 1260                    | 1160    | 1090    |
| 80/26.7   | 1250                    | 1150    | 1140    |
| 90/32.2   | 1240                    | 1140    | 1180    |
| 100/37.8  | 1170                    | 1080    | 1010    |
| 110/43.3  | 1090                    | 1000    | 940     |
| Based on average ice slab weight of 10.0- 11.0 lb<br>Ratings with JC1395 condenser, dice or half dice cubes |                         |         |         |

**Operating Pressures**

| Air Temp. Entering Condenser °F/°C                           | Freeze Cycle            |                       | Harvest Cycle           |                       |
|--|-------------------------|-----------------------|-------------------------|-----------------------|
|  | Discharge Pressure PSIG | Suction Pressure PSIG | Discharge Pressure PSIG | Suction Pressure PSIG |
| -20/-28.9 to 50/10.0   | 220-250                 | 40-22                 | 135-170                 | 75-95                 |
| 70/21.1  | 240-260                 | 40-22                 | 140-180                 | 80-95                 |
| 80/26.7  | 240-270                 | 41-22                 | 140-190                 | 80-95                 |
| 90/32.2  | 250-290                 | 42-22                 | 140-200                 | 80-95                 |
| 100/37.8   | 280-320                 | 46-22                 | 140-210                 | 80-95                 |
| 110/43.3   | 310-360                 | 48-24                 | 140-220                 | 85-100                |
| Suction pressure drops gradually throughout the freeze cycle |                         |                       |                         |                       |

**Q1600 SERIES**

**Self-Contained Water-Cooled**

NOTE: These characteristics may vary depending on operating conditions.

**Cycle Times**

Freeze Time + Harvest Time = Total Cycle Time

| Air Temp. Entering Condenser °F/°C | Freeze Time             |         |          | Harvest Time |
|------------------------------------|-------------------------|---------|----------|--------------|
|                                    | Water Temperature °F/°C |         |          |              |
|                                    | 50/10.0                 | 70/21.1 | 90/32.2  |              |
| 70/21.1                            | 7.2-8.1                 | 8.0-9.0 | 8.9-9.9  | 1-2.5        |
| 80/26.7                            | 7.3-8.2                 | 8.1-9.1 | 9.2-10.2 |              |
| 90/32.2                            | 7.4-8.2                 | 8.2-9.1 | 9.6-10.7 |              |
| 100/37.8                           | 7.4-8.3                 | 8.4-9.4 | 9.7-10.8 |              |
| Times in minutes                   |                         |         |          |              |

**24 Hour Ice Production**

| Air Temp. Entering Condenser °F/°C                 | Water Temperature °F/°C |         |         |
|--|-------------------------|---------|---------|
|  | 50/10.0                 | 70/21.1 | 90/32.2 |
| 70/21.1  | 1650                    | 1510    | 1390    |
| 80/26.7  | 1635                    | 1500    | 1350    |
| 90/32.2  | 1625                    | 1490    | 1300    |
| 100/37.8   | 1620                    | 1450    | 1290    |
| 70/21.1  | 1650                    | 1510    | 1390    |
| Based on average ice slab weight of 13.0 -14.12 lb |                         |         |         |

| Condenser Water Consumption Gal/24 hours                           | 90/32.2 Air Temperature Around Ice Machine |         |         |
|--|--|---------|---------|
|  | Water Temperature °F/°C                    |         |         |
|  | 50/10.0                                    | 70/21.1 | 90/32.2 |
|  | 1400                                       | 2235    | 6500    |
| Water regulating valve set to maintain 240 PSIG discharge pressure |  |         |         |

**Operating Pressures**

| Air Temp. Entering Condenser °F/°C                           | Freeze Cycle            |                       | Harvest Cycle           |                       |
|--|-------------------------|-----------------------|-------------------------|-----------------------|
|  | Discharge Pressure PSIG | Suction Pressure PSIG | Discharge Pressure PSIG | Suction Pressure PSIG |
| -20/-28.9 to 50/10.0   | 235-245                 | 48-24                 | 145-170                 | 70-90                 |
| 70/21.1  | 235-265                 | 52-26                 | 150-175                 | 70-90                 |
| 80/26.7  | 235-270                 | 52-26                 | 150-175                 | 75-95                 |
| 90/32.2  | 235-280                 | 52-28                 | 155-180                 | 75-95                 |
| 100/37.8   | 240-285                 | 52-28                 | 155-180                 | 80-100                |
| 110/43.3   | 240-290                 | 54-28                 | 155-185                 | 80-100                |
| Suction pressure drops gradually throughout the freeze cycle |                         |                       |                         |                       |

**Q1600 SERIES**

**Remote**

NOTE: These characteristics may vary depending on operating conditions.

**Cycle Times**

Freeze Time + Harvest Time = Total Cycle Time

| Air Temp. Entering Condenser °F/°C | Freeze Time             |           |           | Harvest Time |
|------------------------------------|-------------------------|-----------|-----------|--------------|
|                                    | Water Temperature °F/°C |           |           |              |
|                                    | 50/10.0                 | 70/21.1   | 90/32.2   |              |
| -20 to 70<br>-29 to 21.1           | 7.5-8.4                 | 8.2-9.2   | 9.0-10.1  | 1 - 2.5      |
| 90/32.2                            | 8.0-8.9                 | 8.6-9.6   | 9.2-10.3  |              |
| 100/37.8                           | 8.4-9.3                 | 9.2-10.2  | 9.7-10.8  |              |
| 110/43.3                           | 9.2-10.3                | 10.0-11.2 | 10.4-11.6 |              |
| Times in minutes                   |                         |           |           |              |

**24 Hour Ice Production**

| Air Temp. Entering Condenser °F/°C  | Water Temperature °F/°C |         |         |
|---|-------------------------|---------|---------|
|   | 50/10.0                 | 70/21.1 | 90/32.2 |
| -20 to 70<br>-29 to 21.1  | 1600                    | 1478    | 1370    |
| 90/32.2   | 1523                    | 1425    | 1340    |
| 100/37.8  | 1460                    | 1350    | 1290    |
| 110/43.3  | 1343                    | 1250    | 1213    |
| Based on average ice slab weight of 13.0- 14.12lb<br>Ratings with JC1895 condenser, dice or half dice cubes |                         |         |         |

**Operating Pressures**

| Air Temp. Entering Condenser °F/°C                           | Freeze Cycle            |                       | Harvest Cycle           |                       |
|--|-------------------------|-----------------------|-------------------------|-----------------------|
|  | Discharge Pressure PSIG | Suction Pressure PSIG | Discharge Pressure PSIG | Suction Pressure PSIG |
| -20 to 50/-29 to 10.0  | 220-255                 | 52-26                 | 100-120                 | 70-85                 |
| 70/21.1  | 250-270                 | 56-28                 | 110-120                 | 75-90                 |
| 80/26.7  | 250-275                 | 56-28                 | 110-120                 | 75-90                 |
| 90/32.2  | 255-285                 | 56-28                 | 110-120                 | 80-90                 |
| 100/37.8   | 270-310                 | 56-30                 | 115-130                 | 80-95                 |
| 110/43.3   | 305-350                 | 58-32                 | 120-135                 | 80-100                |
| Suction pressure drops gradually throughout the freeze cycle |                         |                       |                         |                       |

**Q1800 SERIES**

**Self-Contained Air-Cooled**

NOTE: These characteristics may vary depending on operating conditions.

**Cycle Times**

Freeze Time + Harvest Time = Total Cycle Time

| Air Temp. Entering Condenser °F/°C | Freeze Time             |           |           | Harvest Time |
|------------------------------------|-------------------------|-----------|-----------|--------------|
|                                    | Water Temperature °F/°C |           |           |              |
|                                    | 50/10.0                 | 70/21.1   | 90/32.2   |              |
| 70/21.1                            | 8.5-9.3                 | 9.4-10.3  | 9.9-10.9  | 1-2.5        |
| 80/26.7                            | 9.0-9.9                 | 9.8-10.8  | 10.5-11.5 |              |
| 90/32.2                            | 9.6-10.5                | 10.4-11.5 | 11.1-12.2 |              |
| 100/37.8                           | 10.6-11.6               | 11.5-12.6 | 12.4-13.6 |              |
| Times in minutes                   |                         |           |           |              |

**24 Hour Ice Production**

| Air Temp. Entering Condenser °F/°C  | Water Temperature °F/°C |         |         |
|---|-------------------------|---------|---------|
|   | 50/10.0                 | 70/21.1 | 90/32.2 |
| 70/21.1   | 1880                    | 1720    | 1640    |
| 80/26.7   | 1780                    | 1650    | 1560    |
| 90/32.2   | 1690                    | 1570    | 1480    |
| 100/37.8  | 1550                    | 1440    | 1350    |
| Based on average ice slab weight of 13.0 - 14.12lb<br>Regular cube derate is 7% |                         |         |         |

**Operating Pressures**

| Air Temp. Entering Condenser °F/°C                           | Freeze Cycle            |                       | Harvest Cycle           |                       |
|--|-------------------------|-----------------------|-------------------------|-----------------------|
|  | Discharge Pressure PSIG | Suction Pressure PSIG | Discharge Pressure PSIG | Suction Pressure PSIG |
| 50/10.0  | 220-280                 | 40-20                 | 155-190                 | 60-80                 |
| 70/21.1  | 220-280                 | 40-20                 | 160-190                 | 65-80                 |
| 80/26.7  | 230-290                 | 42-20                 | 160-190                 | 65-80                 |
| 90/32.2  | 260-320                 | 44-22                 | 185-205                 | 70-90                 |
| 100/37.8   | 300-360                 | 46-24                 | 210-225                 | 75-100                |
| 110/43.3   | 320-400                 | 48-26                 | 215-240                 | 80-100                |
| Suction pressure drops gradually throughout the freeze cycle |                         |                       |                         |                       |



**Q1800 SERIES**

**Self-Contained Water-Cooled**

NOTE: These characteristics may vary depending on operating conditions.

**Cycle Times**

Freeze Time + Harvest Time = Total Cycle Time

| Air Temp. Around Ice Machine °F/°C | Freeze Time             |          |           | Harvest Time |
|------------------------------------|-------------------------|----------|-----------|--------------|
|                                    | Water Temperature °F/°C |          |           |              |
|                                    | 50/10.0                 | 70/21.1  | 90/32.2   |              |
| 70/21.1                            | 8.7-9.6                 | 9.6-10.5 | 10.8-11.9 | 1-2.5        |
| 80/26.7                            | 9.0-9.9                 | 9.6-10.6 | 10.8-11.9 |              |
| 90/32.2                            | 9.1-10.1                | 9.7-10.7 | 10.9-12.0 |              |
| 100/37.8                           | 9.2-10.1                | 9.8-10.7 | 11.1-12.1 |              |

Times in minutes

**24 Hour Ice Production**

| Air Temp. Around Ice Machine °F/°C | Water Temperature °F/°C |         |         |
|------------------------------------|-------------------------|---------|---------|
|                                    | 50/10.0                 | 70/21.1 | 90/32.2 |
| 70/21.1                            | 1840                    | 1690    | 1520    |
| 80/26.7                            | 1780                    | 1680    | 1520    |
| 90/32.2                            | 1760                    | 1670    | 1510    |
| 100/37.8                           | 1750                    | 1660    | 1490    |

Based on average ice slab weight of 13.0- 14.12lb  
Regular cube derate is 7%

| Condenser Water Consumption | 90/32.2 Air Temperature Around Ice Machine |         |         |
|-----------------------------|--|---------|---------|
|                             | Water Temperature °F/°C                    |         |         |
|                             | 50/10.0                                    | 70/21.1 | 90/32.2 |
| Gal/24 hours                | 2000                                       | 2670    | 7750    |

Water regulating valve set to maintain 240 PSIG discharge pressure

**Operating Pressures**

| Air Temp. Around Ice Machine °F/°C | Freeze Cycle            |                       | Harvest Cycle           |                       |
|------------------------------------|-------------------------|-----------------------|-------------------------|-----------------------|
|                                    | Discharge Pressure PSIG | Suction Pressure PSIG | Discharge Pressure PSIG | Suction Pressure PSIG |
| 50/10.0                            | 235-245                 | 36-20                 | 170-190                 | 65-80                 |
| 70/21.1                            | 235-245                 | 38-20                 | 170-190                 | 65-80                 |
| 80/26.7                            | 235-245                 | 40-20                 | 170-190                 | 65-80                 |
| 90/32.2                            | 235-250                 | 42-22                 | 175-190                 | 65-80                 |
| 100/37.8                           | 235-255                 | 44-22                 | 175-190                 | 65-80                 |
| 110/43.3                           | 235-260                 | 46-22                 | 175-190                 | 65-80                 |

Suction pressure drops gradually throughout the freeze cycle

**Q1800 SERIES**

**Remote**

NOTE: These characteristics may vary depending on operating conditions.

**Cycle Times**

Freeze Time + Harvest Time = Total Cycle Time

| Air Temp. Entering Condenser °F/°C | Freeze Time             |           |           | Harvest Time |
|------------------------------------|-------------------------|-----------|-----------|--------------|
|                                    | Water Temperature °F/°C |           |           |              |
|                                    | 50/10.0                 | 70/21.1   | 90/32.2   |              |
| -20/-28.9 to 70/21.1               | 9.1-10.0                | 9.8-10.8  | 10.7-11.7 | 1-2.5        |
| 80/26.7                            | 9.3-10.2                | 10.1-11.1 | 10.9-12.0 |              |
| 90/32.2                            | 9.5-10.5                | 10.3-11.4 | 11.1-12.2 |              |
| 100/37.8                           | 10.1-11.1               | 11.1-12.2 | 11.9-13.0 |              |
| 110/43.3                           | 11.0-12.1               | 12.1-13.2 | 12.7-13.9 |              |

Times in minutes

**24 Hour Ice Production**

| Air Temp. Entering Condenser °F/°C | Water Temperature °F/°C |         |         |
|------------------------------------|-------------------------|---------|---------|
|                                    | 50/10.0                 | 70/21.1 | 90/32.2 |
| -20/-28.9 to 70/21.1               | 1770                    | 1650    | 1540    |
| 80/26.7                            | 1735                    | 1615    | 1510    |
| 90/32.2                            | 1700                    | 1580    | 1480    |
| 100/37.8                           | 1620                    | 1480    | 1400    |
| 110/43.3                           | 1500                    | 1380    | 1320    |

Based on average ice slab weight of 13.0 - 14.12lb  
Regular cube derate is 7%  
Ratings with JC1895 condenser, dice or half dice cubes

**Operating Pressures**

| Air Temp. Entering Condenser °F/°C | Freeze Cycle            |                       | Harvest Cycle           |                       |
|------------------------------------|-------------------------|-----------------------|-------------------------|-----------------------|
|                                    | Discharge Pressure PSIG | Suction Pressure PSIG | Discharge Pressure PSIG | Suction Pressure PSIG |
| -20/-28.9 to 50/10.0               | 220-250                 | 38-24                 | 160-180                 | 60-80                 |
| 70/21.1                            | 220-260                 | 40-24                 | 170-180                 | 60-80                 |
| 80/26.7                            | 250-270                 | 48-24                 | 175-190                 | 70-90                 |
| 90/32.2                            | 250-280                 | 50-24                 | 180-200                 | 80-90                 |
| 100/37.8                           | 270-300                 | 52-28                 | 205-215                 | 80-95                 |
| 110/43.3                           | 300-350                 | 54-28                 | 205-230                 | 80-100                |

Suction pressure drops gradually throughout the freeze cycle

## Refrigerant Recovery/Evacuation and Recharging

### NORMAL SELF-CONTAINED MODEL PROCEDURES

#### Refrigerant Recovery/Evacuation

Do not purge refrigerant to the atmosphere. Capture refrigerant using recovery equipment. Follow the manufacturer's recommendations.

#### Important

Manitowoc Ice, Inc. assumes no responsibility for the use of contaminated refrigerant. Damage resulting from the use of contaminated refrigerant is the sole responsibility of the servicing company.

#### Important

Replace the liquid line drier before evacuating and recharging. Use only a Manitowoc (O.E.M.) liquid line filter drier to prevent voiding the warranty.

### CONNECTIONS

1. Suction side of the compressor through the suction service valve.
2. Discharge side of the compressor through the discharge service valve.

### SELF-CONTAINED RECOVERY/EVACUATION

1. Place the toggle switch in the OFF position.
2. Install manifold gauges, charging cylinder/scale, and recovery unit or two-stage vacuum pump.

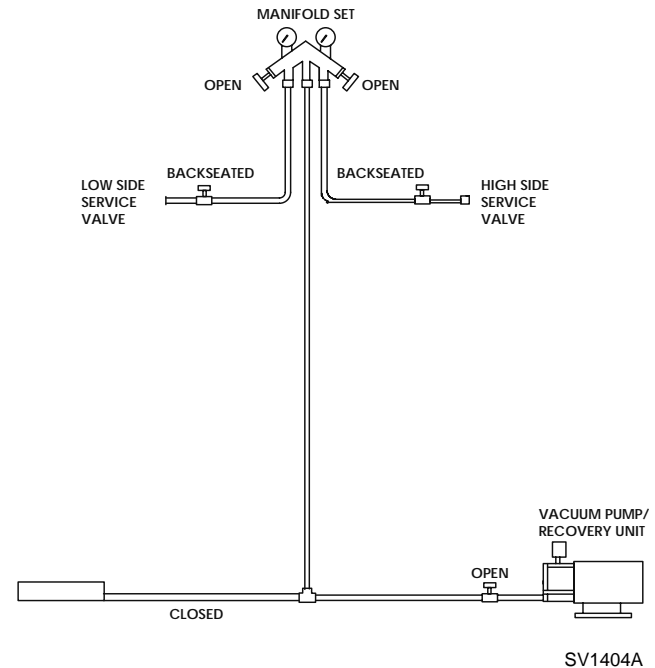

**Figure 7-14. Recovery/Evacuation Connections**

3. Open (backseat) the high and low side ice machine service valves, and open high and low side on manifold gauges.
4. Perform recovery or evacuation:
  - A. Recovery: Operate the recovery unit as directed by the manufacturer's instructions.
  - B. Evacuation prior to recharging: Pull the system down to 250 microns. Then, allow the pump to run for an additional half hour. Turn off the pump and perform a standing vacuum leak check.

**NOTE:** Check for leaks using a halide or electronic leak detector after charging the ice machine.

5. Refer to Charging Procedures.

## Self-Contained Charging Procedures

**Important**

The charge is critical on all Manitowoc ice machines. Use a scale or a charging cylinder to ensure the proper charge is installed.

1. Be sure the toggle switch is in the OFF position.

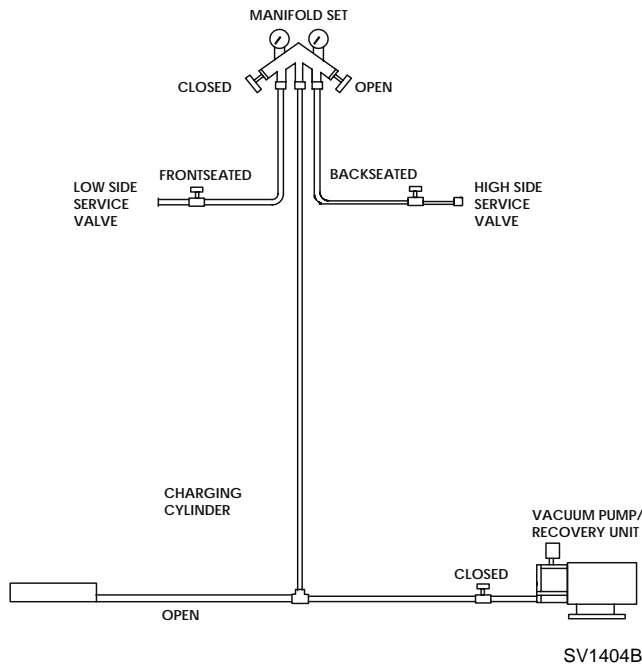

**Figure 7-15. Charging Connections**

2. Close the vacuum pump valve, the low side service valve, and the low side manifold gauge valve.
3. Open the high side manifold gauge valve, and backseat the high side service valve.
4. Open the charging cylinder and add the proper refrigerant charge (shown on nameplate) through the discharge service valve.
5. Let the system “settle” for 2 to 3 minutes.
6. Place the toggle switch in the ICE position.
7. Close the high side on the manifold gauge set. Add any remaining vapor charge through the suction service valve (if necessary).

**NOTE:** Manifold gauges must be removed properly to ensure that no refrigerant contamination or loss occurs.

8. Make sure that all of the vapor in the charging hoses is drawn into the ice machine before disconnecting the charging hoses.
  - A. Run the ice machine in freeze cycle.
  - B. Close the high side service valve at the ice machine.
  - C. Open the low side service valve at the ice machine.
  - D. Open the high and low side valves on the manifold gauge set. Any refrigerant in the lines will be pulled into the low side of the system.
  - E. Allow the pressures to equalize while the ice machine is in the freeze cycle.
  - F. Close the low side service valve at the ice machine.

Remove the hoses from the ice machine and install the caps.

**NORMAL REMOTE MODEL PROCEDURES****Refrigerant Recovery/Evacuation**

Do not purge refrigerant to the atmosphere. Capture refrigerant using recovery equipment. Follow the manufacturer's recommendations.

**Important**

Manitowoc Ice, Inc. assumes no responsibility for the use of contaminated refrigerant. Damage resulting from the use of contaminated refrigerant is the sole responsibility of the servicing company.

**Important**

Replace the liquid line drier before evacuating and recharging. Use only a Maniowoc (O.E.M.) liquid line filter drier to prevent voiding the warranty.

**CONNECTIONS****Important**

Recovery/evacuation of a remote system requires connections at four points for complete system evacuation. See the drawing on next page.

Make these connections:

- Suction side of the compressor through the suction service valve.
- Discharge side of the compressor through the discharge service valve.
- Receiver outlet service valve, which evacuates the area between the check valve in the liquid line and the pump down solenoid.
- Access (Schraeder) valve on the discharge line quick-connect fitting, located on the outside of the compressor/evaporator compartment. This connection evacuates the condenser. Without it, the magnetic check valves would close when the pressure drops during evacuation, preventing complete evacuation of the condenser.

NOTE: Maniowoc recommends using an access valve core removal and installation tool on the discharge line quick-connect fitting. This permits access valve core removal. This allows for faster evacuation and charging, without removing the manifold gauge hose.

**REMOTE RECOVERY/EVACUATION**

1. Place the toggle switch in the OFF position.
2. Install manifold gauges, charging cylinder/scale, and recovery unit or two-stage vacuum pump.
3. Open (backseat) the high and low side ice machine service valves.
4. Open the receiver service valve halfway.
5. Open high and low side on the manifold gauge set.
6. Perform recovery or evacuation:
  - A. Recovery: Operate the recovery unit as directed by the manufacturer's instructions.
  - B. Evacuation prior to recharging: Pull the system down to 250 microns. Then, allow the pump to run for an additional hour. Turn off the pump and perform a standing vacuum leak check.

NOTE: Check for leaks using a halide or electronic leak detector after charging the ice machine.

7. Refer to Charging Procedures.

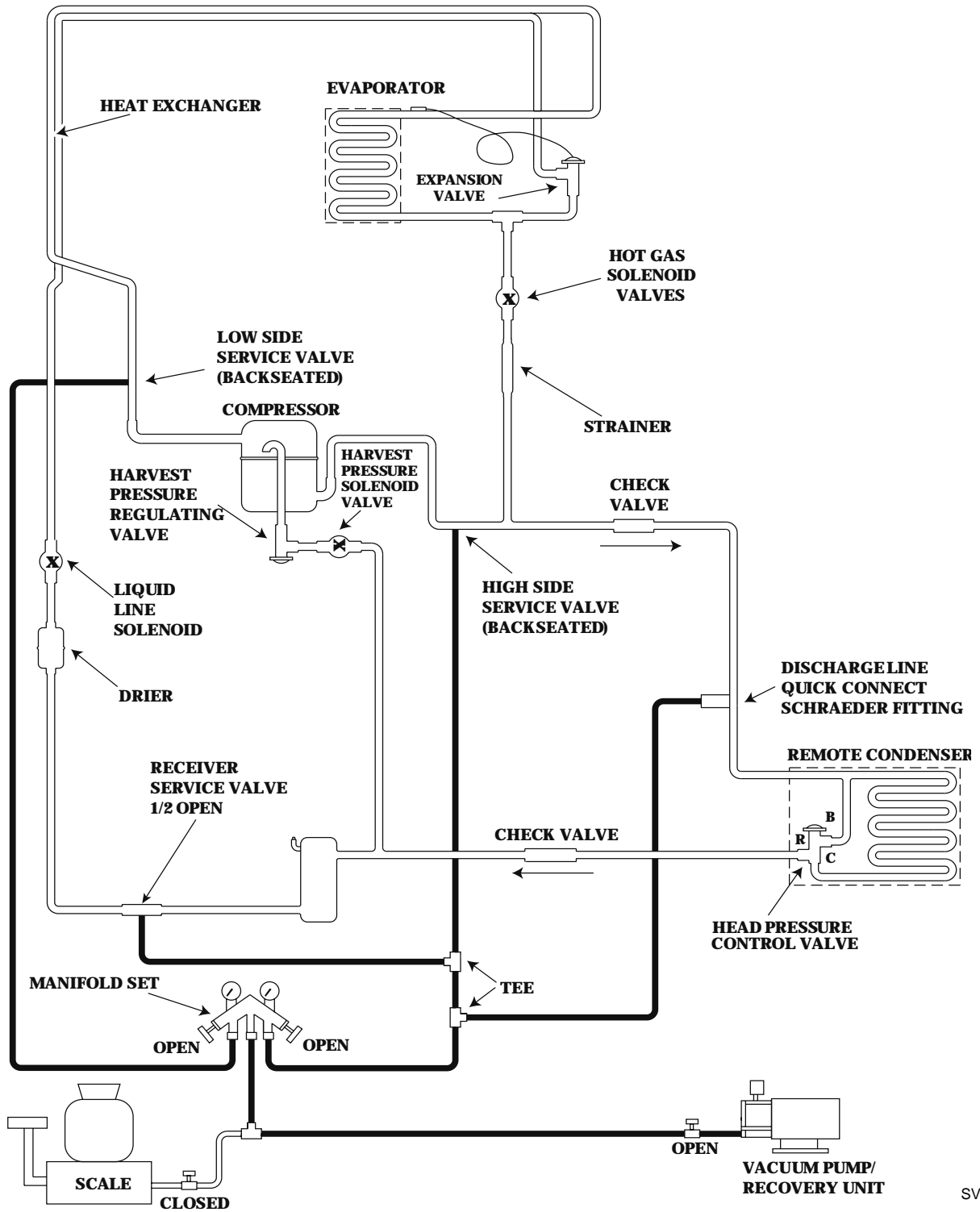

SV1461

Figure 7-16. Recovery/Evacuation Connections

**Remote Charging Procedures**

1. Be sure the toggle switch is in the OFF position.
2. Close the vacuum pump valve, the low and high side service valves (frontseat), and the low side manifold gauge valve.
3. Open the charging cylinder and add the proper refrigerant charge (shown on nameplate) into the system high side (receiver outlet valve and discharge lines quick-connect fitting).
4. If the high side does not take the entire charge, close the high side on the manifold gauge set, and backseat (open) the low side service valve and receiver outlet service valve. Start the ice machine and add the remaining charge through the low side (in vapor form) until the machine is fully charged.
5. Ensure all vapor in charging hoses is drawn into the machine, then disconnect the manifold gauges.

NOTE: Backseat the receiver outlet service valve after charging is complete and before operating the ice machine. If the access valve core removal and installation tool is used on the discharge quick-connect fitting, reinstall the Schraeder valve core before disconnecting the access tool and hose.

6. Run the ice machine in freeze cycle.
7. Close the high side service valve at the ice machine.
8. Open the low side service valve at the ice machine.
9. Open the high and low side valves on the manifold gauge set. Any refrigerant in the lines will be pulled into the low side of the system.
10. Allow the pressures to equalize while the ice machine is in the freeze cycle.
11. Close the low side service valve at the ice machine.
12. Remove the hoses from the ice machine and install the caps.

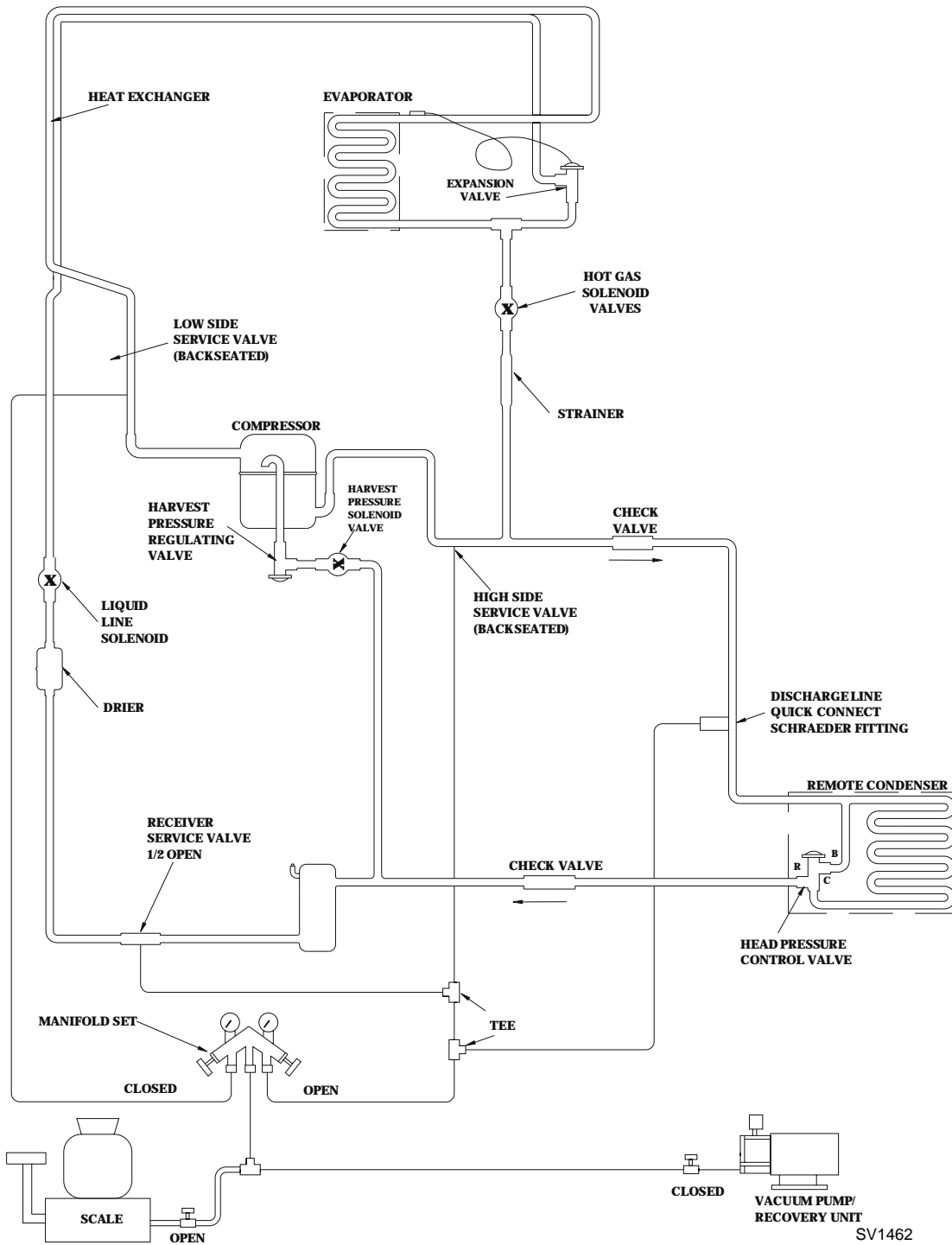

Figure 7-17. Remote Charging Connections

**SYSTEM CONTAMINATION CLEAN-UP**

**General**

This section describes the basic requirements for restoring contaminated systems to reliable service.

**Important**

Manitowoc Ice, Inc. assumes no responsibility for the use of contaminated refrigerant. Damage resulting from the use of contaminated refrigerant is the sole responsibility of the servicing company.

**Determining Severity Of Contamination**

System contamination is generally caused by either moisture or residue from compressor burnout entering the refrigeration system.

Inspection of the refrigerant usually provides the first indication of system contamination. Obvious moisture or an acrid odor in the refrigerant indicates contamination.

If either condition is found, or if contamination is suspected, use a Total Test Kit from Totaline or a similar diagnostic tool. These devices sample refrigerant, eliminating the need to take an oil sample. Follow the manufacturer's directions.

If a refrigerant test kit indicates harmful levels of contamination, or if a test kit is not available, inspect the compressor oil.

1. Remove the refrigerant charge from the ice machine.
2. Remove the compressor from the system.
3. Check the odor and appearance of the oil.
4. Inspect open suction and discharge lines at the compressor for burnout deposits.
5. If no signs of contamination are present, perform an acid oil test.

Check the chart below to determine the type of cleanup required.

| <b>Contamination/Cleanup Chart</b>  |  |
|---|--|
| <b>Symptoms/Findings</b>  | <b>Required Cleanup Procedure</b>      |
| No symptoms or suspicion of contamination   | Normal evacuation/recharging procedure |
| <b>Moisture/Air Contamination symptoms</b><br>Refrigeration system open to atmosphere for longer than 15 minutes<br>Refrigeration test kit and/or acid oil test shows contamination<br>Leak in water-cooled condenser<br>No burnout deposits in open compressor lines | Mild contamination cleanup procedure   |
| <b>Mild Compressor Burnout symptoms</b><br>Oil appears clean but smells acrid<br>Refrigeration test kit or acid oil test shows harmful acid content<br>No burnout deposits in open compressor lines   | Mild contamination cleanup procedure   |
| <b>Severe Compressor Burnout symptoms</b><br>Oil is discolored, acidic, and smells acrid<br>Burnout deposits found in the compressor and lines, and in other components   | Severe contamination cleanup procedure |



**Mild System Contamination Cleanup Procedure**

1. Replace any failed components.
2. If the compressor is good, change the oil.
3. Replace the liquid line drier.

NOTE: If the contamination is from moisture, use heat lamps during evacuation. Position them at the compressor, condenser and evaporator prior to evacuation. Do not position heat lamps too close to plastic components, or they may melt or warp.

**Important**

Dry nitrogen is recommended for this procedure. This will prevent CFC release.

4. Follow the normal evacuation procedure, except replace the evacuation step with the following:
  - A. Pull vacuum to 1000 microns. Break the vacuum with dry nitrogen and sweep the system. Pressurize to a minimum of 5 psi.
  - B. Pull vacuum to 500 microns. Break the vacuum with dry nitrogen and sweep the system. Pressurize to a minimum of 5 psi.
  - C. Change the vacuum pump oil.
  - D. Pull vacuum to 250 microns. Run the vacuum pump for 1/2 hour on self-contained models, 1 hour on remotes.

NOTE: You may perform a standing vacuum test to make a preliminary leak check. You should use an electronic leak detector after system charging to be sure there is no leak.

5. Charge the system with the proper refrigerant to the nameplate charge.
6. Operate the ice machine.

**Severe System Contamination Cleanup Procedure**

1. Remove the refrigerant charge.
2. Remove the compressor.
3. Disassemble the hot gas solenoid valve. If burnout deposits are found inside the valve, install a rebuild kit, and replace manifold strainer, TXV and harvest pressure regulating valve.
4. Wipe away any burnout deposits from suction and discharge lines at compressor.
5. Sweep through the open system with dry nitrogen.

**Important**

Refrigerant sweeps are not recommended, as they release CFC's into the atmosphere.

6. Install a new compressor and new start components.
7. Install a suction line filter-drier with acid and moisture removal capability (P/N 89-3028-3). Place the filter drier as close to the compressor as possible.
8. Install an access valve at the inlet of the suction line drier.
9. Install a new liquid line drier.

Continued on next page ...

10. Follow the normal evacuation procedure, except replace the evacuation step with the following:

**Important**

Dry nitrogen is recommended for this procedure. This will prevent CFC release.

- A. Pull vacuum to 1000 microns. Break the vacuum with dry nitrogen and sweep the system. Pressurize to a minimum of 5 psi.
- B. Change the vacuum pump oil.
- C. Pull vacuum to 500 microns. Break the vacuum with dry nitrogen and sweep the system. Pressurize to a minimum of 5 psi.
- D. Change the vacuum pump oil.
- E. Pull vacuum to 250 microns. Run the vacuum pump for 1/2 hour on self-contained models, 1 hour on remotes.

NOTE: You may perform a standing vacuum test to make a preliminary leak check. You should use an electronic leak detector after system charging to be sure there is no leak.

11. Charge the system with the proper refrigerant to the nameplate charge.
12. Operate the ice machine for one hour. Then, check the pressure drop across the suction line filter-drier.
  - A. If the pressure drop is less than 1 psi, the filter-drier should be adequate for complete cleanup.
  - B. If the pressure drop exceeds 1 psi, change the suction line filter-drier and the liquid line drier. Repeat until the pressure drop is acceptable.
13. Operate the ice machine for 48-72 hours. Then, remove the suction line drier and change the liquid line drier.
14. Follow normal evacuation procedures.

**REPLACING PRESSURE CONTROLS WITHOUT REMOVING REFRIGERANT CHARGE**

This procedure reduces repair time and cost. Use it when any of the following components require replacement, and the refrigeration system is operational and leak-free.

- Fan cycle control (air-cooled only)
- Water regulating valve (water-cooled only)
- High pressure cut-out control
- High side service valve
- Low side service valve

**Important**

This is a required in-warranty repair procedure.

1. Disconnect power to the ice machine.
2. Follow all manufacturer's instructions supplied with the pinch-off tool. Position the pinch-off tool around the tubing as far from the pressure control as feasible. (See the figure on next page.) Clamp down on the tubing until the pinch-off is complete.

 **Warning**

Do not unsolder a defective component. Cut it out of the system. Do not remove the pinch-off tool until the new component is securely in place.

3. Cut the tubing of the defective component with a small tubing cutter.
4. Solder the replacement component in place. Allow the solder joint to cool.
5. Remove the pinch-off tool.
6. Re-round the tubing. Position the flattened tubing in the proper hole in the pinch off tool. Tighten the wingnuts until the block is tight and the tubing is rounded. (See the drawing on next page.)

NOTE: The pressure controls will operate normally once the tubing is re-rounded. Tubing may not re-round 100%.

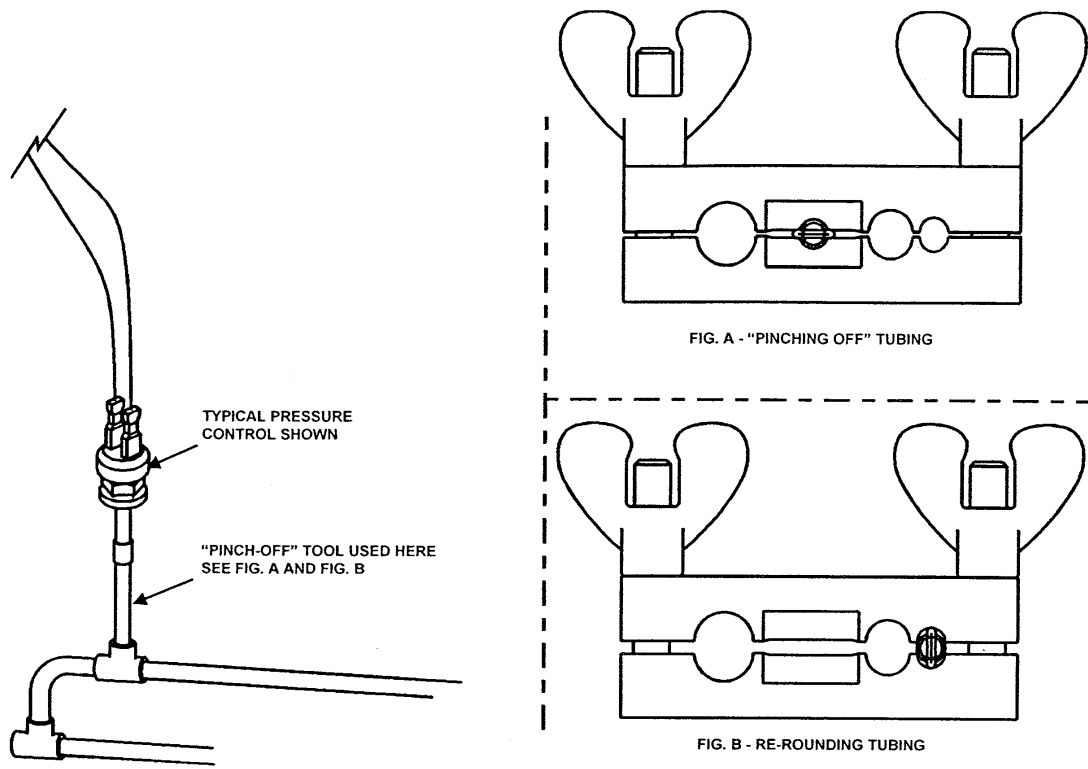

SV1406

Figure 7-18. Using Pinch-Off Tool

**FILTER-DRIERS**

The filter-driers used on Manitowoc ice machines are manufactured to Manitowoc specifications.

The difference between Manitowoc driers and off-the-shelf driers is in filtration. Manitowoc driers have dirt-retaining filtration, with fiberglass filters on both the inlet and outlet ends. This is very important because ice machines have a back-flushing action which takes place during every harvest cycle.

These filter-driers have a very high moisture removal capability and a good acid removal capacity.

The size of the filter-drier is important. The refrigerant charge is critical. Using an improperly sized filter-drier will cause the ice machine to be improperly charged with refrigerant.

Listed below are the recommended O.E.M. field replacement driers:

| Model   | Drier Size | End Connection Size | Part Number |
|---|------------|---------------------|-------------|
| Self-Contained Air and Water Cooled<br>Q200 /Q280/Q320<br>Q370/Q420/Q450<br>Q600/Q800/Q1000 | UK-032S    | 1/4"                | 89-3025-3   |
| Remote Air Cooled<br>Q450/Q600<br>Q800/Q1000  | UK-083S    | 3/8"                | 89-3027-3   |
| All Condenser Type<br>Q1300/Q1600<br>Q1800  | UK-083S    | 3/8"                | 89-3027-3   |
| Suction Filter  | UK-165S    | 5/8"                | 89-3028-3   |
| Suction Filter used when cleaning up severely contaminated systems                          |            |                     |             |

**Important**

Driers are covered as a warranty part. The drier must be replaced any time the system is opened for repairs.

**TOTAL SYSTEM REFRIGERANT CHARGES**

**Important**

Refer to the ice machine serial number tag to verify the system charge.

| Series    | Version      | Charge     |
|-----------|--------------|------------|
| Q200      | Air-Cooled   | 18 oz.     |
|           | Water-Cooled | 15 oz.     |
| Q210      | Air-Cooled   | 15 oz.     |
|           | Water-Cooled | 11 oz.     |
| Q280      | Air-Cooled   | 18 oz.     |
|           | Water-Cooled | 15 oz.     |
| Q320      | Air-Cooled   | 20 oz.     |
|           | Water-Cooled | 16 oz.     |
| Q370      | Air-Cooled   | 20 oz.     |
|           | Water-Cooled | 17 oz.     |
| Q420/Q450 | Air-Cooled   | 24 oz.     |
|           | Water-Cooled | 22 oz.     |
|           | Remote       | 6 lb.      |
| Q600      | Air-Cooled   | 28 oz.     |
|           | Water-Cooled | 22 oz.     |
|           | Remote       | 8 lb.      |
| Q800      | Air-Cooled   | 36 oz.     |
|           | Water-Cooled | 25 oz.     |
|           | Remote       | 8 lb.      |
| Q1000     | Air-Cooled   | 38 oz.     |
|           | Water-Cooled | 32 oz.     |
|           | Remote       | 9.5 lb.    |
| Q1300     | Air-Cooled   | 48 oz.     |
|           | Water-Cooled | 44 oz.     |
|           | Remote       | 12.5 lb. * |
| Q1600     | Water-Cooled | 46 oz.     |
|           | Remote       | 15 lb.*    |
| Q1800     | Air-Cooled   | 56 oz.     |
|           | Water-Cooled | 46 oz.     |
|           | Remote       | 15 lb.*    |

\*For remote line sets with lengths between 50' and 100' refer to chart on **Page 2-13**

NOTE: All ice machines on this list are charged using R-404A refrigerant.

**REFRIGERANT DEFINITIONS****Recover**

To remove refrigerant, in any condition, from a system and store it in an external container, without necessarily testing or processing it in any way.

**Recycle**

To clean refrigerant for re-use by oil separation and single or multiple passes through devices, such as replaceable core filter-driers, which reduce moisture, acidity and particulate matter. This term usually applies to procedures implemented at the field job site or at a local service shop.

**Reclaim**

To reprocess refrigerant to new product specifications (see below) by means which may include distillation. A chemical analysis of the refrigerant is required after processing to be sure that product specifications are met. This term usually implies the use of processes and procedures available only at a reprocessing or manufacturing facility.

Chemical analysis is the key requirement in this definition. Regardless of the purity levels reached by a reprocessing method, refrigerant is not considered "reclaimed" unless it has been chemically analyzed and meets ARI Standard 700 (latest edition).

**New Product Specifications**

This means ARI Standard 700 (latest edition). Chemical analysis is required to assure that this standard is met.

**REFRIGERANT RE-USE POLICY**

Manitowoc recognizes and supports the need for proper handling, re-use, and disposal of, CFC and HCFC refrigerants. Manitowoc service procedures require recapturing refrigerants, not venting them to the atmosphere.

It is not necessary, in or out of warranty, to reduce or compromise the quality and reliability of your customers' products to achieve this.

**Important**

Manitowoc Ice, Inc. assumes no responsibility for use of contaminated refrigerant. Damage resulting from the use of contaminated, recovered, or recycled refrigerant is the sole responsibility of the servicing company.

Manitowoc approves the use of:

**1. New Refrigerant**

- Must be of original nameplate type.

**2. Reclaimed Refrigerant**

- Must be of original nameplate type.
- Must meet ARI Standard 700 (latest edition) specifications.

**3. Recovered or Recycled Refrigerant**

- Must be recovered or recycled in accordance with current local, state and federal laws.
- Must be recovered from and re-used in the same Manitowoc product. Re-use of recovered or recycled refrigerant from other products is not approved.
- Recycling equipment must be certified to ARI Standard 740 (latest edition) and be maintained to consistently meet this standard.
- Recovered refrigerant must come from a "contaminant-free" system. To decide whether the system is contaminant free, consider:
  - Type(s) of previous failure(s)
  - Whether the system was cleaned, evacuated and recharged properly following failure(s)
  - Whether the system has been contaminated by this failure
  - Compressor motor burnouts and improper past service prevent refrigerant re-use.
  - Refer to "System Contamination Cleanup" to test for contamination.

**4. "Substitute" or "Alternative" Refrigerant**

- Must use only Manitowoc-approved alternative refrigerants.
- Must follow Manitowoc-published conversion procedures.

**HFC REFRIGERANT QUESTIONS AND ANSWERS**

Manitowoc uses R-404A and R-134A HFC refrigerants with ozone depletion potential (ODP) factors of zero (0.0). R-404A is used in ice machines and reach-in freezers and R-134A is used in reach-in refrigerators.

1. What compressor oil does Manitowoc require for use with HFC refrigerants?

Manitowoc products use Polyol Ester (POE) type compressor oil. It is the lubricant of choice among compressor manufacturers.

2. What are some of the characteristics of POE oils?

They are hygroscopic, which means they have the ability to absorb moisture. POE oils are 100 times more hygroscopic than mineral oils. Once moisture is absorbed into the oil, it is difficult to remove, even with heat and vacuum. POE oils are also excellent solvents, and tend to “solvent clean” everything inside the system, depositing material where it is not wanted.

3. What do these POE oil characteristics mean to me?

You must be more exacting in your procedures. Take utmost care to prevent moisture from entering the refrigeration system. Refrigeration systems and compressors should not be left open to the atmosphere for more than 15 minutes. Keep oil containers and compressors capped at all times to minimize moisture entry. Before removing the system charge to replace a faulty component, be sure you have all of the needed components at the site. Remove new system component plugs and caps just prior to brazing. Be prepared to connect a vacuum pump immediately after brazing.

4. Are there any special procedures required if a POE system is diagnosed with a refrigerant leak?

For systems found with positive refrigerant system pressure, no special procedures are required.

For systems found without any positive refrigerant pressure, assume that moisture has entered the POE oil. After the leak is found and repaired, the compressor oil must be changed. The compressor must be removed and at least 95% of the oil drained from the suction port of the compressor. Use a “measuring cup” to replace the old oil with exactly the same amount of new POE oil, such as Mobil EAL22A.

Remember, care must be taken to prevent moisture from getting into the refrigeration system during refrigeration repairs.

5. How do I leak-check a system containing HFC refrigerant?

Use equipment designed for HFC detection. Do not use equipment designed for CFC detection. Consult leak detection equipment manufacturers for their recommendations. Also, standard soap bubbles will work with HFC refrigerants.

6. Does Manitowoc use a special liquid line filter-drier with HFC refrigerants?

Yes. Manitowoc uses an ALCO “UK” series filter-drier for increased filtration and moisture removal. During a repair, Manitowoc recommends installing the drier just before hooking up a vacuum pump.

Continued on next page ...

7. Is other special equipment required to service HFC refrigerants?

No. Standard refrigeration equipment such as gauges, hoses, recovery systems, vacuum pumps, etc., are generally compatible with HFC refrigerants. Consult your equipment manufacturer for specific recommendations for converting existing equipment to HFC usage. Once designated (and calibrated, if needed) for HFC use, this equipment should be used specifically with HFC refrigerants only.

8. Do I have to recover HFC refrigerants?

Yes. Like other refrigerants, government regulations require recovering HFC refrigerants.

9. Will R-404A or R-134A separate if there is a leak in the system?

No. Like R-502, the degree of separation is too small to detect.

10. How do I charge a system with HFC refrigerant?

The same as R-502. Manitowoc recommends charging only liquid refrigerant into the high side of the system.



THIS PAGE INTENTIONALLY LEFT BLANK

THIS PAGE INTENTIONALLY LEFT BLANK



## **Attend A Manitowoc Factory Service School**

- Improve Your Service Techniques
- Network with Your Peers
- 4 1/2 Days of Intensive Training on Manitowoc Ice Machines
- Extensive “Hands On” Training on a Variety of Equipment
- Breakfast, Lunch and Hotel Room Included with Tuition
- Contact Your Distributor or Manitowoc Ice, Inc. for Details

OR

- Visit Our Website at [www.manitowocice.com](http://www.manitowocice.com) for School Dates

### **MANITOWOC ICE, INC.**

2110 South 26th Street P.O. Box 1720  
Manitowoc, WI 54221-1720  
Phone: (920) 682-0161  
Service Fax: (920) 683-7585  
Web Site - [www.manitowocice.com](http://www.manitowocice.com)

© 2003 Manitowoc Ice, Inc.  
Litho in U.S.A.