

GAS OPERATED BOILER

INSTALLATION, OPERATING, MAINTENANCE & PARTS MANUAL



MODELS:

- M24G100A-4SP
- M24G200A-4SP
- M36G100A-4SP
- M36G200A-4SP
- M36G300A-4SP

WARNING:

IMPROPER INSTALLATION, ADJUSTMENT, ALTERATION, SERVICE OR MAINTENANCE CAN CAUSE PROPERTY DAMAGE, INJURY OR DEATH. READ THE INSTALLATION, OPERATION AND MAINTENANCE INSTRUCTIONS THOROUGHLY BEFORE INSTALLING OR SERVICING THIS EQUIPMENT.

FOR YOUR SAFETY:

DO NOT STORE OR USE GASOLINE OR OTHER FLAMMABLE VAPORS AND LIQUIDS IN THE VICINITY OF THIS OR ANY OTHER APPLIANCE.

Post instructions in a prominent location to be followed in the event the user smells gas. This information shall be obtained by consulting the local gas supplier.

Form Number: S-2404 REV: E 06/08

Printed in U.S.A.



35 Garvey Street • Everett • MA • 02149
Tel: (617) 387-4100 • Fax: (617) 387-4456 • Outside MA Fax: (800) 227-2659
E-Mail: CUSTSERV@mfi.com • Website: www.mfi.com

TABLE OF CONTENTS

INTRODUCTION	ii
TO THE KITCHEN MANAGER	ii
INTRODUCTION	ii
HOW TO USE THIS MANUAL	ii
THEORY OF OPERATION FOR GAS BOILER	ii
INSTALLATION INSTRUCTIONS (Gas Operated Boiler)	1-4
INSTALLING LEGS	1
LEVELING	1
LOWER DEFLECTOR PLATE	1
GAS SERVICE CONNECTIONS	2
ELECTRIC SERVICE CONNECTIONS	2
ISERVICE CONNECTIONS	3
INSTALLATION INSTRUCTIONS FOR THE LOWER DEFLECTOR ASSEMBLY	4
OPERATING INSTRUCTIONS	5-6
DAILY OPERATING PROCEDURE	5
DAILY SHUT DOWN AND CLEANING	5
LIGHTING INSTRUCTIONS, SPARK PILOT	6
ADJUSTMENTS	6
IF GAS PRESSURE IS LOW OR TOO HIGH	6
PRESSURE CONTROL SWITCH ADJUSTMENT	7
GENERAL TROUBLE-SHOOTING	8-9
TESTING PROCEDURE	10
WATER CONTROL BOARD TESTING PROCEDURE	10
ILLUSTRATED PARTS LIST	11-17
BOILER BASE CABINET (24") PARTS LIST	11
PRESSURE SWITCH BOX WITHOUT COVER	12
CONTROL BOX ASSEMBLY WITH & WITHOUT COVER	13
PLUMBING SECTION	14
PARTS (200,000 BTU)	15
PARTS (Gas Train)	16
ELECTRICAL INFORMATION	18-19
WIRING DIAGRAM FOR NEW GENERATION BOILERS	18
WIRING SCHEMATIC FOR NEW GENERATION BOILERS	19
MAINTENANCE	20-21
CLEANING THE BOILER	20
REPLACEMENT PARTS	20
CLEANING INSTRUCTIONS	20
APPLICATION INSTRUCTIONS	22-23

INTRODUCTION

TO THE KITCHEN MANAGER:

1. Read this manual carefully and in its entirety. Contact Market Forge Ind., Inc. for clarification if necessary.
2. Protect your kitchen personnel from scalding and other serious injury by providing training programs to acquaint all equipment operators with the correct and safe methods of operation.
3. Operators must be made aware of the consequences of misuse. Steam producing equipment, no matter who the manufacturer, is inherently dangerous when misused. The possibility of serious scalding always exists, the careless and/or untrained operator will be injured.
4. This equipment must be maintained according to the guidelines in this manual (see "maintenance"). Lack of maintenance will lead to a potentially hazardous condition and possible liability. Operators should report any equipment malfunction immediately and steps must be taken to correct the problem before further use of the equipment is allowed.
5. Keep this manual for daily reference.

INTRODUCTION:

Market Forge, in the interest of both cost and efficiency has designed these steam boilers with the latest automatic controls in order to make it easier for the operator to use and maintain this equipment. Standard components are utilized on all models unless variances in size or capacity dictate a divergence from this policy for more efficiency of operation. This parts and service manual is written and illustrated to cover all steam boiler equipment that uses gas as a source of fuel other than those which have been custom designed under special order.

HOW TO USE THIS MANUAL:

The pictures of components are aids to the identification, disassembly and assembly of parts. The parts listing provides information necessary for the ordering of replacement parts (proper part names and part numbers). When requesting parts or service always furnish the model and serial number of your complete unit, this will indicate to Market Forge Service Personnel the type of boiler that you have. This information can be found on the nameplate attached to the boiler frame.

THEORY OF OPERATION FOR GAS BOILER:

An explanation of how the control system operates on automatic gas boilers follows:
After the boiler is filled with water to the proper level and the fuel switch is turned ON, the main gas valve will be activated allowing gas to flow to the main burners that will be ignited by the Spark Pilot. When the boiler builds to its set pressure, the pressure switch opens. This will open the circuit to the gas valve that will stop the flow of gas to the main burners. As the pressure in the boiler drops the pressure control switch will again complete the circuit and build the boiler back to its set pressure. To stop all steam generation place the FILL/ON-OFF switch to the OFF position.

INSTALLATION INSTRUCTIONS

GAS OPERATED BOILERS

MODELS:

- M24G100A - 4SP
- M24G200A - 4SP
- M36G100A - 4SP
- M36G200A - 4SP
- M36G300A - 4SP

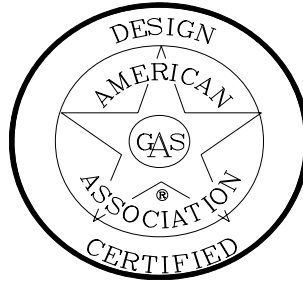

CAUTION: BE SURE TO READ:

- ▶ Keep this appliance area free and clear from combustibles.
- ▶ Do not obstruct the flow of combustion and ventilation air.
- ▶ Keep this manual for future reference.
- ▶ This installation must conform with local codes, or in the absence of local codes, with the National Fuel Gas code, ANSI Z223.1-Latest Edition. For installation in Canada, this appliance is to be in accordance with the current CAN/CGA-B149(.1 or .2) Installation Code for Gas Burning Appliances and Equipment and/or Local Codes.
- ▶ This appliance, when installed, must be electrically grounded in accordance with local codes, or in the absence of local codes, with the National Electric Code, ANSI/NFPA70-Latest Edition. For installation in Canada, All electrical connections are to be made in accordance with CSA C22.1 Canadian Electrical Code Part 1 and/or Local Codes.
- ▶ The boiler and its individual shut off valve must be disconnected from the gas supply piping system during any pressure testing of that system at test pressure in excess of 1/2 psig (3.45 k/PA).
- ▶ The boiler must be isolated from the gas supply system by closing its individual manual shut off valve during any pressure testing of the gas supply piping system at test pressures equal to or less than 1/2 psig (3.45 k/PA).
- ▶ The wiring diagram label is located on the inside of the Lift-Off Front Panel.
- ▶ This product must be installed in a room with adequate air supply.
- ▶ Do not place any objects on or directly against the unit as to block air openings into the combustion chamber.
- ▶ Clearances from both combustible and non-combustible construction are 3" (76mm) from side walls, 6" (152mm) from rear wall. With lower deflector plate, shown on page 4, installed this unit is suitable for Installation on Combustible Floors.
- ▶ This unit is serviceable from the front, do not install in such a manner where a service person cannot remove front panels.

INSTALLING LEGS:

Some models are shipped without legs. A separate carton will contain the legs. If your model is received this way, be sure to follow the installation instruction sheet packed with the legs.

LEVELING:

In order for the boiler to drain correctly, it is important to use a level on cabinet top both left and right and front-to-back. If not level, adjust feet. On compartment cookers, check the interior shelves for level condition.

LOWER DEFLECTOR PLATE:

The lower deflector plate must be installed on the boiler. Be sure to follow the installation instructions located on page 4.

INSTALLATION INSTRUCTIONS

***GAS SERVICE CONNECTIONS:**

- a) The boiler is factory adjusted for a gas input of 100, 200 & 300K BTU/HR at the pressure indicated. Please read the rating plate behind the Lift-Off Front Panel. If this plate is marked for a different gas than that supplied, notify your dealer immediately. Install an external gas supply shut off valve in a visible and accessible location. If the unit is placed at the minimum side clearances rather than the optimum side clearances, the only acceptable location for the gas supply shut off valve is under the unit in the space provided by the legs.
- b) Use new iron or steel pipe complying with the latest ANSI Standard for Wrought-Steel and Wrought-Iron Pipe, B36, properly threaded, reamed and free from chips, oil and dirt. If pipe dope is used, apply a moderate amount leaving two end threads bare. Pipe dope must be resistant to LP gas. Connect the gas line into the bottom (inlet) side of the shutoff valve. The supply pressure must be at least 1" (25mm) water column higher than the manifold or regulator pressure for proper functioning of the regulator. If it is not check the supply pipe for blockage or excessive pressure drop and make necessary corrections.
- c) Perform a gas leak test of all newly-made joints, as well as those leading to the main gas control valve. Use a soap solution, DO NOT USE FLAME.
- d) Natural gas units are equipped with a pressure regulator factory adjusted to give 4" (102mm) water column manifold pressure.
- e) Propane gas units are equipped with a pressure regulator, factory adjusted, to give 10" (254mm) water column manifold pressure.
- f) ONLY A LICENSED GAS FITTER SHOULD MAKE GAS LINE CONNECTIONS.

***ELECTRIC SERVICE CONNECTION:**

Connect boiler controls to 110/120 volt AC, 60Hz, single phase branch circuit rated 15 amps capacity, using the three prong plug provided.

** Gas and Electrical connections should be made by licensed tradesmen only.*

INSTALLATION INSTRUCTIONS

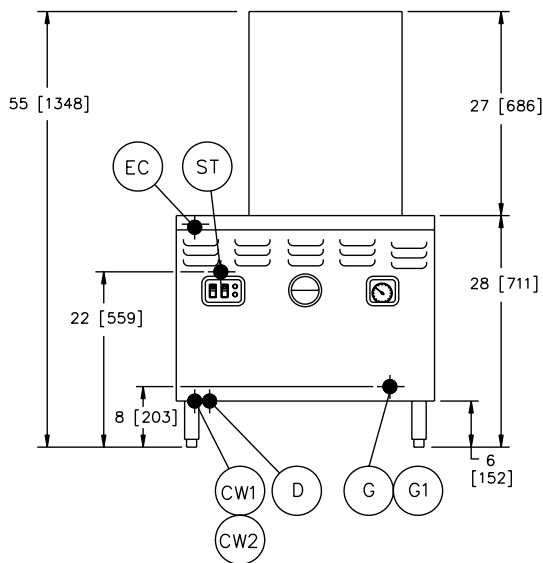
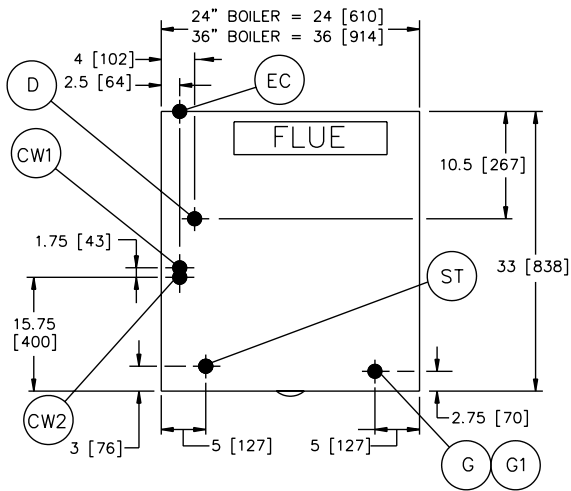

SERVICE CONNECTIONS:

Gas Operated Boilers

G	GasConnection - 3/4" (19mm) IPS (100 & 200K BTU)
G1	Gas Connection - 1" (25mm) IPS (275 & 300K BTU)
CW1	Cold Water - 3/8" (10mm) O.D. tubing for cold water to boiler. Cold water lines will have a max of 50PSI (3.5 kg/cm ²) and a min of 25PSI (1.8 kg/cm ²) water pressure. CAUTION: FILTER SYSTEM INSTALLATION INSTRUCTIONS MUST BE ADHERED TO WHEN CONNECTING A FILTER TO THIS LINE.
CW2	Cold Water - 3/8" (10mm) O.D. tubing for cold water to condenser. Cold water lines will have a max of 50PSI (3.5 kg/cm ²) and a min of 25PSI (1.8 kg/cm ²) water pressure.
D	Drain - Pipe full 2" (51mm) IPS to flush floor drain capable of receiving water flowing at a max rate of 5 gal. (19 liters) per minute. DO NOT MAKE SOLID CONNECTION TO FLOOR DRAIN.
EC	Electrical Connection - 120 volt A.C. 60Hz, 1/2" (13mm) conduit connection or equivalent. Use wire suitable for a least 90°C. Amp for 115 steam generator controls is 2 amps.
ST	Steam Take-off - Connection for operation of adjacent steam powered equipment.

NOTES: If equipment is installed where elevation exceeds 2,000 feet (609.6 meters) above sea level, specify installation altitude so that proper gas orifices can be provided.

The only available space to supply utilities to the gas boiler is the 6" (152mm) space between the floor and the cabinet. Allow 3" (76mm) space from side wall and 6" (152mm) from real wall if adjoining walls are combustible.

CAUTION: Before connecting water to this unit, water supply should be analyzed to make sure hardness is no greater than 2.0 grains and pH level is within the range of 7.0-8.5. Water which fails to meet these standards should be treated by installation of water conditioner. EQUIPMENT FAILURE CAUSED BY INADEQUATE WATER QUALITY IS NOT COVERED UNDER WARRANTY.

WASTE LINE INSTALLATION: The drain port of the unit is marked with a colored tag and is located at the lower rear left side of the boiler as viewed from the front. This exhaust line may be left open if the boiler has to be situated in a tiled floor depression or a tiled curb section that is equipped with drain facilities. If this is not the case, then a 2" (51mm) NPT. drain line must be connected to divert the exhaust to the floor drain. If it is necessary to use more than three elbows, increase the size of the waste line accordingly.

NOTE:
PVC & CPVC PIPE ARE NOT ACCEPTABLE MATERIALS FOR DRAINS.

WARNING:
DO NOT UNDER ANY CIRCUMSTANCE CONNECT THE EXHAUST DRAIN LINE DIRECTLY TO A SEWER LINE.

INSTALLATION INSTRUCTIONS

LOWER DEFLECTOR ASSEMBLY

Lower Deflector	
200 Boiler	98-3972
300 Boiler	98-3976
Upper Deflector	
200 Boiler	94-5115
300 Boiler	94-5095

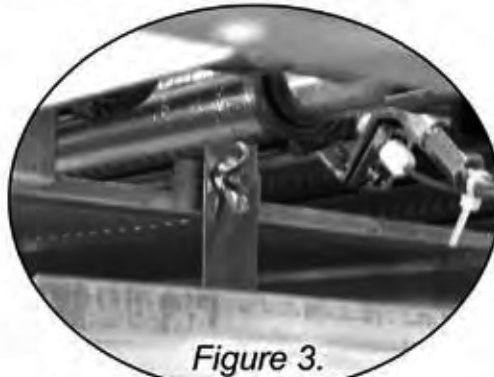

Figure 3.

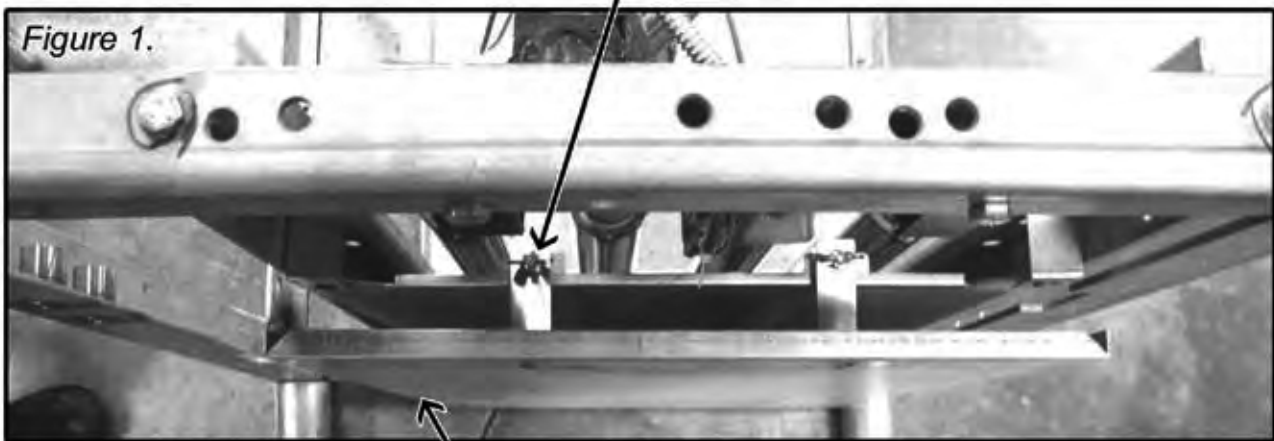

Figure 1.

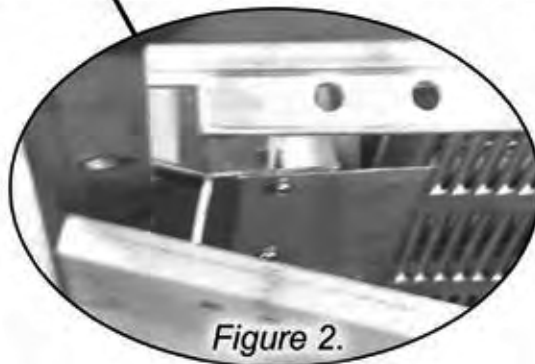

Figure 2.

To Install the Lower Deflector as shown in *Figure 1.*, the following steps must be taken:

1. Locate lower deflector as shown in *Figure 2.* The rear brackets will slide in openings and allow it to rest in place on frame.
2. Move lower deflector slightly forward to allow front brackets to fit over 8-32 studs protruding out from the upper deflector plate as shown in *Figure 3.*
3. Secure lower deflector in place as shown in *Figure 1.* using 8-32 stainless steel wing nuts (*part number 08-7835*).

OPERATING INSTRUCTIONS

MODELS:

- M24G100A - 4SP
- M24G200A - 4SP
- M36G100A - 4SP
- M36G200A - 4SP
- M36G300A - 4SP

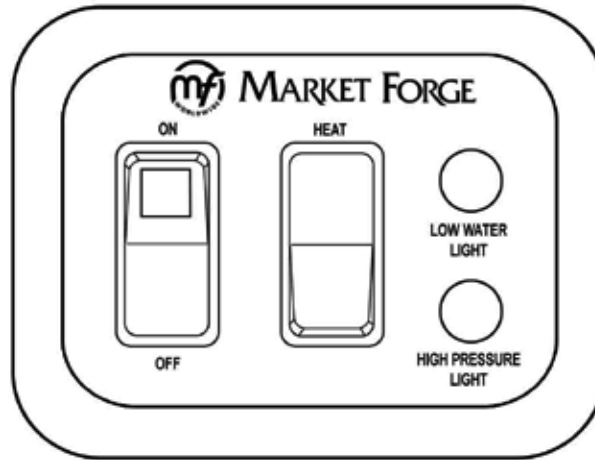

Control Panel



OPERATING INSTRUCTIONS STEAM GENERATORS

FIRST CHECK TO BE SURE THAT:

- A. WATER SWITCH IS IN THE OFF POSITION.
- B. WATER SUPPLY VALVE IS OPEN.
- C. ELECTRICITY IS CONNECTED TO ALL UNITS.
- D. THAT THE GAS IS TURNED ON. (GAS OPERATED UNITS ONLY)
- E. THEN PROCEED WITH DAILY OPERATING PROCEDURES.

DAILY OPERATING PROCEDURE

STEP 1 PRESS WATER SWITCH FROM OFF TO ON.

STEP 2 WAIT 5-10 MINUTES FOR WATER TO FILL IN STEAM GENERATOR (GAUGE GLASS SHOULD BE 2/3 FULL.)

STEP 3 PRESS HEAT SWITCH FROM ON TO OFF AND RELEASE BACK TO ON WHEN THE LOW WATER LIGHT GOES OFF. GREEN INDICATOR LIGHT WILL COME ON. (THIS IS NECESSARY TO MANUALLY RESET THE UNIT.)

DAILY SHUT DOWN AND CLEANING

STEP 1 PRESS WATER SWITCH OFF. THIS WILL DRAIN THE STEAM GENERATOR.

STEP 2 AFTER STEAM GENERATOR HAS COMPLETELY DRAINED REPEAT STEPS 1 & 2 OF DAILY OPERATING PROCEDURE. (WATER TO REMAIN IN STEAM GENERATOR UNTIL NEXT DAILY USE.)

OPERATING INSTRUCTIONS

CAUTION: BE SURE TO READ:

- ▶ Disconnect The Power Supply to the boiler before servicing or cleaning.
- ▶ Keep the appliance area free and clear of combustibles.
- ▶ Do not obstruct the flow of combustion and ventilation air.
- ▶ Keep this manual for future reference.
- ▶ Contact the factory, the factory representative, or an authorized service company to perform maintenance and repairs.
- ▶ In the event of a power failure, no attempt should be made to operate the appliance. Be sure the water switch is in the OFF position.

LIGHTING INSTRUCTION, SPARK PILOT: (Be sure boiler drain valve is closed)

1. Press water switch from OFF to ON.
2. Wait 5 to 10 minutes for water to fill in the boiler (Gauge glass should be 2/3 full).
3. Press the heat switch from ON to OFF and release back to ON position when the low water light goes OFF. Green indicator light will come on (This is necessary to manually reset the unit).

ADJUSTMENTS

A. IF GAS PRESSURE IS LOW:

Check your gas supply line for a restriction. If no restriction exists, check with your Natural gas supplier to provide at least 5" of water column pressure in the gas supply line. If no restriction exists and Propane gas is being used, the tank pressure regulator should be adjusted to supply at least 11" of water column pressure in the gas supply line. If this adjustment cannot be made to your satisfaction, the gas supplier should be notified.

B. IF GAS PRESSURE IS TOO HIGH:

Adjust the pressure regulator on the boiler gas valve to reduce the pressure if Natural gas is being used. If Propane gas is being used, adjust the pressure regulator supplied by the gas supplier. If the regulator cannot be adjusted, notify the gas supplier.

ADJUSTMENTS

SETTING THE BOILER CONTROL PRESSURE SWITCHES:

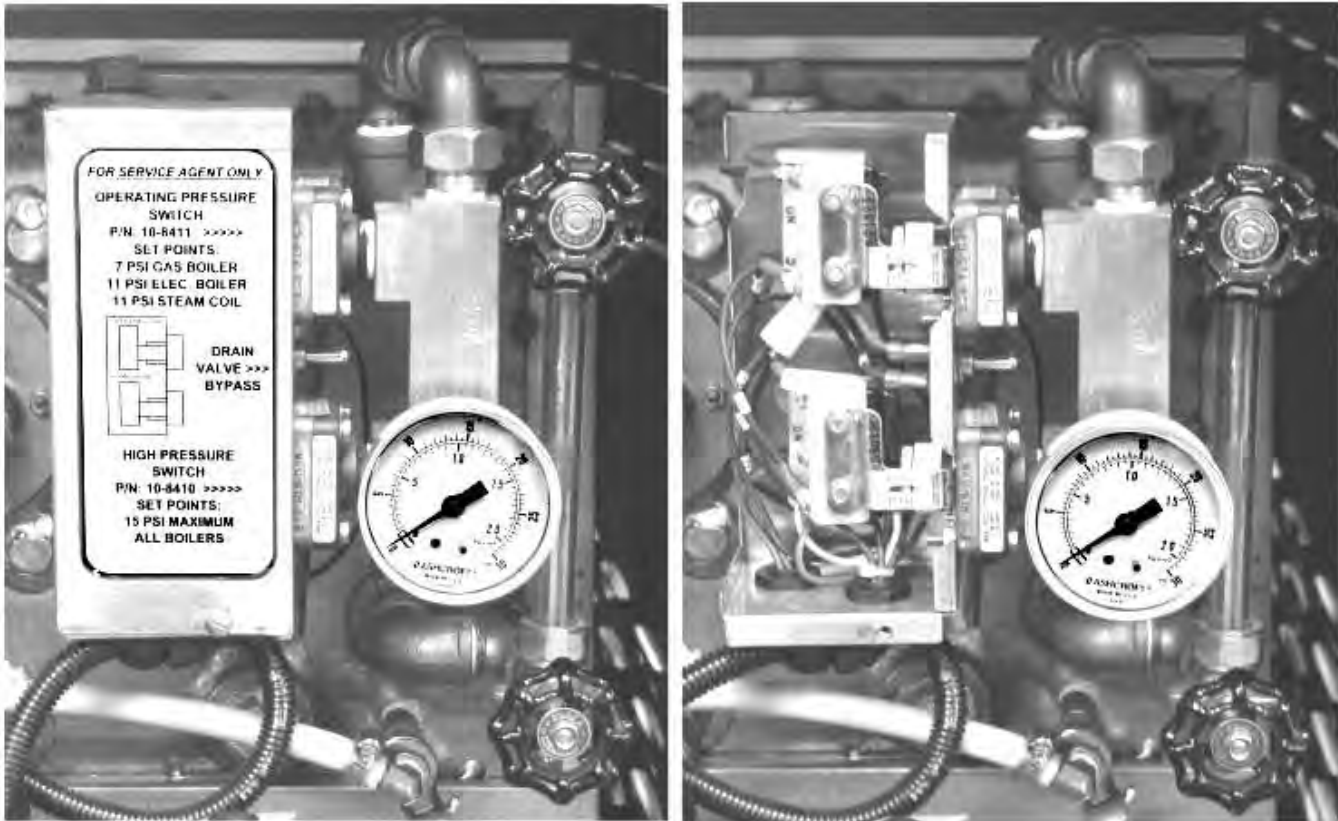

PRESSURE CONTROL SWITCH ADJUSTMENT:

If boiler fails to maintain steam pressure in operating range, pressure control switch may require adjustment.

1. Start boiler and allow pressure to build up to operating level - 7 PSI ($1\text{kg}/\text{cm}^2$).
2. Check boiler pressure gauge. If gauge indicates 5 to 7 PSI, pressure control switches are properly adjusted.
3. If boiler does not come on when pressure gauge reads 7 PSI and does not go off when pressure gauge reads 7 PSI, proceed as follows:

WARNING: Because power must be on to adjust pressure switches, be sure to protect against electrical shock.

- a) Remove screw and lift front cover off control box.
- b) Hand adjust operating pressure control switch and high limit pressure control switch by turning adjusting nut (Knurled knob) clockwise to raise and counter clockwise to lower actuation point. Switch should be set so that boiler comes on when boiler pressure gauge reads 5 PSI and goes off when gauge reads 7 PSI. Switch should be set so that boiler will shut off if pressure reaches 15 PSI.
- c) The actuation value (differential) is factory set and cannot be changed.
- d) The cold water condensor thermostat is preset at factory.
- e) Repeat steps, 1, 2, and 3. If 45 to 7 PSI boiler pressure gauge reading is obtained during boiler operation, adjustment is correct. If proper adjustment cannot be made consult Trouble-Shooting Guide in this manual.
- f) After making adjustments, replace cover on pressure switch box and screw.

GENERAL TROUBL-SHOOTING

TROUBLE	POSSIBLE CAUSE	REMEDY
Pilot will not ignite or does not hold.	<ol style="list-style-type: none"> 1. Gas not reaching unit. 2. Main "gas cock knob" not in ON position. 3. Air pocket or clog in gas line. 4. Defective wiring or poor connection at pilotstat power unit. 5. Defective switching across either the water level control or pressure switches. 6. Defective gas valve. 	<ol style="list-style-type: none"> 1. Check to make sure gas is on and gas line is purged of air. 2. Depress and turn "main gas cock" to pilot position - (refer to lighting instructions). 3. Purge or blow out gas line. 4. Check - replace or tighten. 5. Make continuity check - replace units that are defective. 6. Replace gas valve.
Water enters boiler very slowly.	<ol style="list-style-type: none"> 1. Clogged strainer screen on water fill solenoid valve 2. Debris or lime accumulation on seat of water fill valve. 	<ol style="list-style-type: none"> 1. Clean or replace strainer screen. (P/N 08-4871). 2. Clean valve seat
Boiler overfills with water	<ol style="list-style-type: none"> 1. Probes scaled. 2. Water supply valve fails to close. 3. Defective water level control. 	<ol style="list-style-type: none"> 1. Clean. 2. Clean valve seat or replace valve. 3. Follow the test procedure on page 11. Replace if defective.
Main Burners will not ignite or will not remain lighted.	<ol style="list-style-type: none"> 1. No water in boiler. 2. Main gas cock or supply line not open. 3. Pressure switch set too low. 4. No voltage to gas valve. 5. Gas valve defective. 	<ol style="list-style-type: none"> 1. Check to be sure water switch is on. Check to be sure main water supply is on and the electrical supply to unit is on. 2. Open. 3. Reset - if continuity check shows to be defective - replace. 4. Check main fuse. 5. Replace.
Boiler fails to build up any pressure when the water is at the correct level and the fuel switch is turned on.	<ol style="list-style-type: none"> 1. Check to see that main gas is turned on. 2. Check to see that gas valve is in burners "on" position. 3. Current flow is broken at water level control (ascertain with continuity check). 4. Current flow is broken at pressure control or high limit control switches (ascertain with continuity check). 	<ol style="list-style-type: none"> 1. Turn on. 2. Turn to burners "on". 3. Check for voltage thru right side of control board, replace if defective. 4. Re-adjust to proper setting - refer to instruction for re-adjustment, replace if defective.
Water level in gauge glass fluctuates up and down.	<ol style="list-style-type: none"> 1. Top shutoff valve on water gauge glass is closed. 	<ol style="list-style-type: none"> 1. Open.

GENERAL TROUBL-SHOOTING

TROUBLE	POSSIBLE CAUSE	REMEDY
Boiler fails to reach full operating pressure of 5 lbs. or 15 lbs.	<ol style="list-style-type: none"> 1. Pressure gauge reads inaccurately. 2. Pressure control and high limit control switches are out of adjustment. 3. Safety valve not seating properly. 4. Water level too high. 5. Air vent not venting properly. 6. Insufficient flames on burners or improper gas supply. 	<ol style="list-style-type: none"> 1. Replace. 2. Follow instructions for readjusting. (page 10) 3. Purge manually or replace. 4. Adjust water level control - check water feed valve for sticking - clean or replace. 5. Replace. 6. See instructions on gas adjustments. (page 5)
Boiler fails to cut off after reaching operating pressure.	<ol style="list-style-type: none"> 1. Pressure switch set too high or defective. 2. Gas valve fails to cut off gas supply when demands of pressure switch have been met. 	<ol style="list-style-type: none"> 1. Adjust or replace if defective. 2. Replace gas valve.
Safety valve blows off prematurely.	<ol style="list-style-type: none"> 1. Pressure set too high. 2. Pressure gauge reads incorrectly. 3. Lime or debris on seat of valve 	<ol style="list-style-type: none"> 1. Readjust pressure control. (page 10) 2. Replace. 3. Purge or replace.
Boiler builds up to pressure, shuts down, fails to come back on.	<ol style="list-style-type: none"> 1. 1. High limit switch set to low or operating pressure control switch set too high. 	<ol style="list-style-type: none"> 1. 1. Follow instructions for readjusting, see (page 10) Replace if defective.
Water does not enter boiler.	<ol style="list-style-type: none"> 1. Main water supply off. 2. Power not reaching unit. 3. Probes Dirty. 4. Water level control board defective. 5. Solenoid valve defective 	<ol style="list-style-type: none"> 1. Turn on. 2. Check main fuse or circuit. 3. Remove & Clean 4. See page 11 for test procedure. 5. If Voltage is verified at solenoid coil, but fails to open, replace solenoid.
Cold water condenser does not function.	<ol style="list-style-type: none"> 1. Main water supply off. 2. Thermostat defective. 3. Loose coil nut. 4. Solenoid coil not energized. 	<ol style="list-style-type: none"> 1. Turn on. 2. Replace if defective. 3. Tighten coil nut. 4. Check coil for continuity, if open replace.
Air vent leaking.	<ol style="list-style-type: none"> 1. Not closing. 	<ol style="list-style-type: none"> 1. Replace.

TESTING PROCEDURE

WATER CONTROL BOARD TESTING PROCEDURE

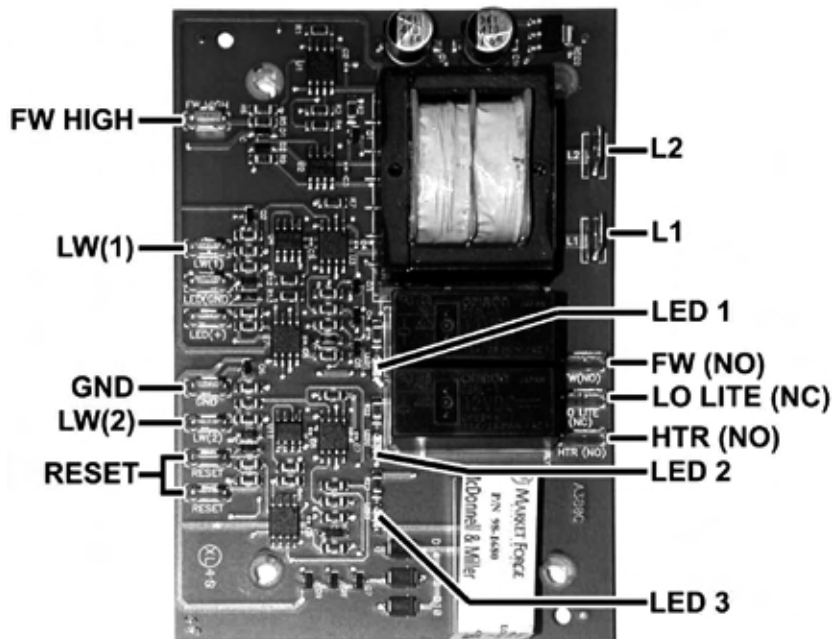

This test procedure is to be used to determine if the control is working properly. It is not intended to determine why the control may have failed.

If testing shows that the control is operating properly, check all probe and solenoid wiring and the condition of the electrodes in the steam chamber.

Contact the factory if the boiler still does not operate properly after completing the testing.

Tools Needed:

- » Digital or Analog V-O-M meter.
- » Alligator clip type test jumpers (2 sets min.).

Turn Off Power to Control:

- » Use V-O-M to verify there is no power at terminals L 1 & L2.
- » Use V-O-M to verify that there is no power at terminals 'FW(NO)', 'LO LITE(NC)' & 'HTR(NO)'. If there is power at any of these terminals, you will need to find the source and turn it off.

Remove Wires from Probe and Relay Switch Terminals:

- » DO NOT remove wires from L 1 & L2 terminals.
- » Tag wires and remove from probe and relay contact terminals including 'GND' terminal.
- » Tag and remove wires from 'RESET' terminals.
- » Connect jumper wire to both 'RESET' terminals.

Turn Power On to Terminals L 1 & L2:

- » 'LED 1' should turn on.
- » 'LED 2' should be off.
- » 'LED 3' should be off.
- » Use V-O-M to verify that there is power at 'FW(NO)' & 'LO LITE(NC)' terminals and no power 'HTR(NO)' terminals

Test Feedwater Function:

- » Connect jumper wire to 'FW HIGH' and 'GND' terminals.

- » 'LED 1' should turn off after a 10 second delay.
- » Use V-O-M to verify that there is no power at the 'FW (NO)' terminal.
- » Remove jumper from 'FW HIGH' and 'GND' terminals. 'LED 1' should turn on.
- » Use V-O-M to verify that there is power at the 'FW(NO)' terminal.

Test Primary Low Water Function:

- » Connect jumper wire to 'LW(1) and 'GND' terminals.
- » 'LED 3' should turn on.
- » Remove jumper wire from 'LW(1)' and 'GND' terminals.
- » 'LED 3' should turn off after a 3 second delay.
- » Connect jumper wire to 'LW(1)' and 'GND' terminals.
- » 'LED 3' should turn on.

IMPORTANT:

Jumper wire between 'LW(1) and 'GND' terminals must remain in place to test secondary low water function.

Test Secondary Low Water Function:

- » Connect jumper wire to 'LW(2)' and 'GND' terminals.
- » 'LED 2' should remain off.

- » Use V-O-M to verify that there is power at the 'LO LITE(NC)' terminal and no power at the 'HTR(NO)' terminal.
- » Remove the jumper wires from the 'RESET' terminals.
- » 'LED 2' should turn on.
- » Use V-O-M to verify that there is no power at the 'LO LITE(NC)' terminal and power at the 'HTR(NO)' terminal.
- » Connect jumper wire to 'RESET' terminals.
- » Remove jumper wire from 'LW(2)' and 'GND' terminals.
- » 'LED 2' should turn off after a 3 second delay.
- » USE V-O-M to verify that there is power at the 'LO LITE(NC)' terminal and no power at the 'HTR(NO)' terminal.
- » Connect jumper wire from 'LW(2)' and 'GND' terminals.
- » 'LED 2' should remain off.

IF ANY OF THE FUNCTIONS DO NOT WORK, REPLACE THE BOARD!

IF ALL FUNCTIONS WORK, TROUBLE-SHOOTING OTHER COMPONENTS WILL BE REQUIRED!

ILLUSTRATED PARTS LIST

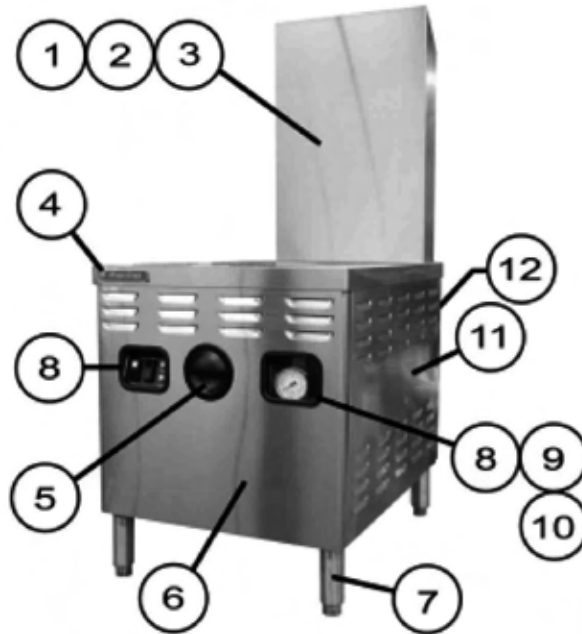

24" Boiler Base Cabinet Shown

ITEM NO.	PART NO.	DESCRIPTION
1	91-8892	Flue Outer, 24" Front
1	91-8938	Flue Outer, 36" Front
2	91-8893	Flue Outer, 24" Back
2	91-2713	Flue Outer, 36" Back
3	98-0593	Flue Inner Assembly, 100 & 200k Boiler
3	91-8936	Flue Inner Assembly, 300k Boiler
4	08-5894	Market Forge Nameplate Logo
5	91-5795	Handle, Front
6	94-5007	Panel, Front Assembly, 24"
6	94-5006	Panel, Front Assembly, 36"
7	10-0631	Leg, 6"
7	08-5206	Leg, 8"
7	08-5211	Leg, 10"
7	08-5208	Leg, Flanged 6"
7	10-0326	Caster, 5"
8	98-3968	Trim, Edge
9	98-3978	Glass
10	98-3991	Gasket, Adhesive
11	98-4010	Panel, Side (<i>Single Panel</i>)
12	98-3995	Panel, Rear Assembly, 24"
12	98-3996	Panel, Rear Assembly, 36"
13	94-5011	Panel Clips (<i>not shown</i>)

ILLUSTRATED PARTS LIST

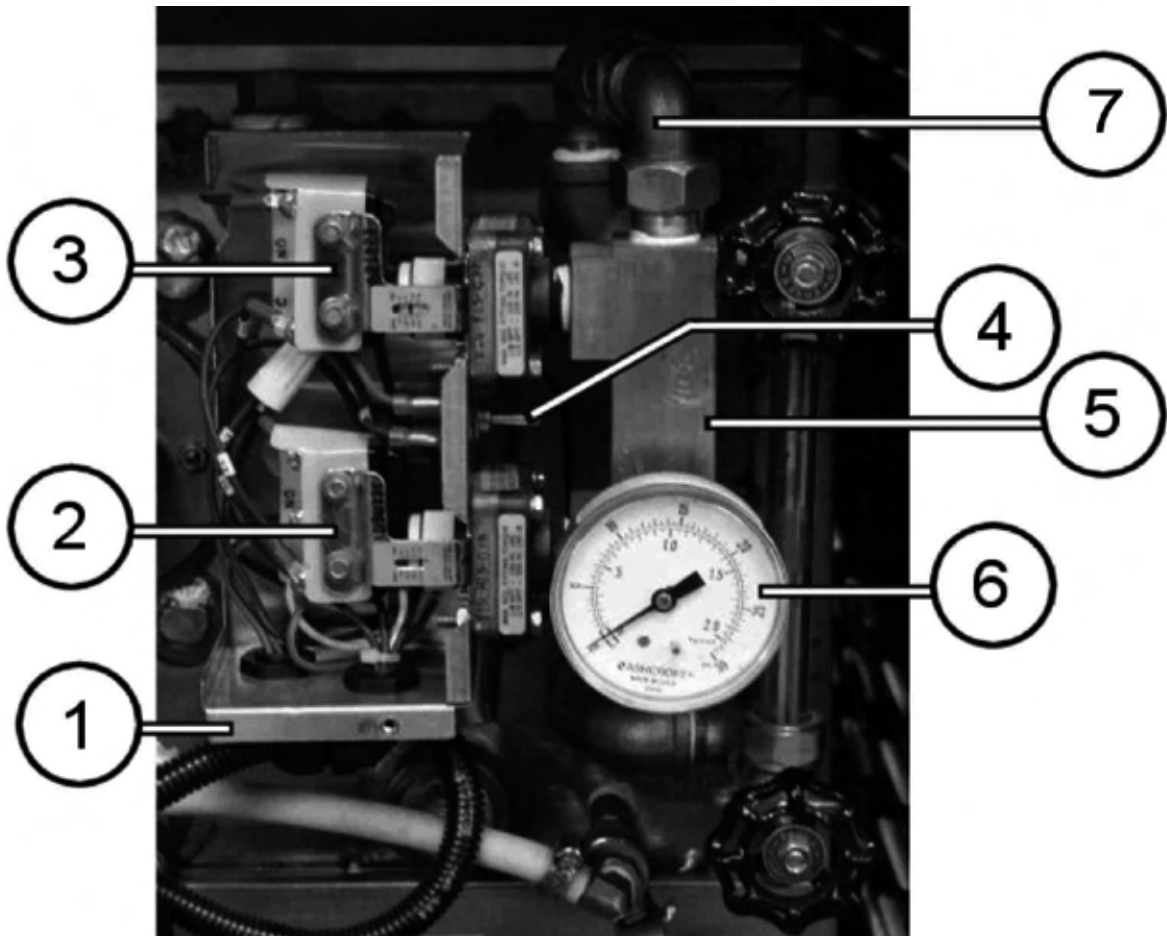

Pressure Switch Box, without Cover

ITEM NO.	PART NO.	DESCRIPTION
1	94-5064	Box, Pressure Switch
2	10-8410	Pressure Switch, Hi-Limit
3	10-8411	Pressure Switch, Operating
4	98-3875	Switch, Drain By-Pass
5	08-7933	Manifold, Pressure Switches
6	10-4804	Pressure Gauge
7	09-4844	Union Elbow, 1/2"

ILLUSTRATED PARTS LIST

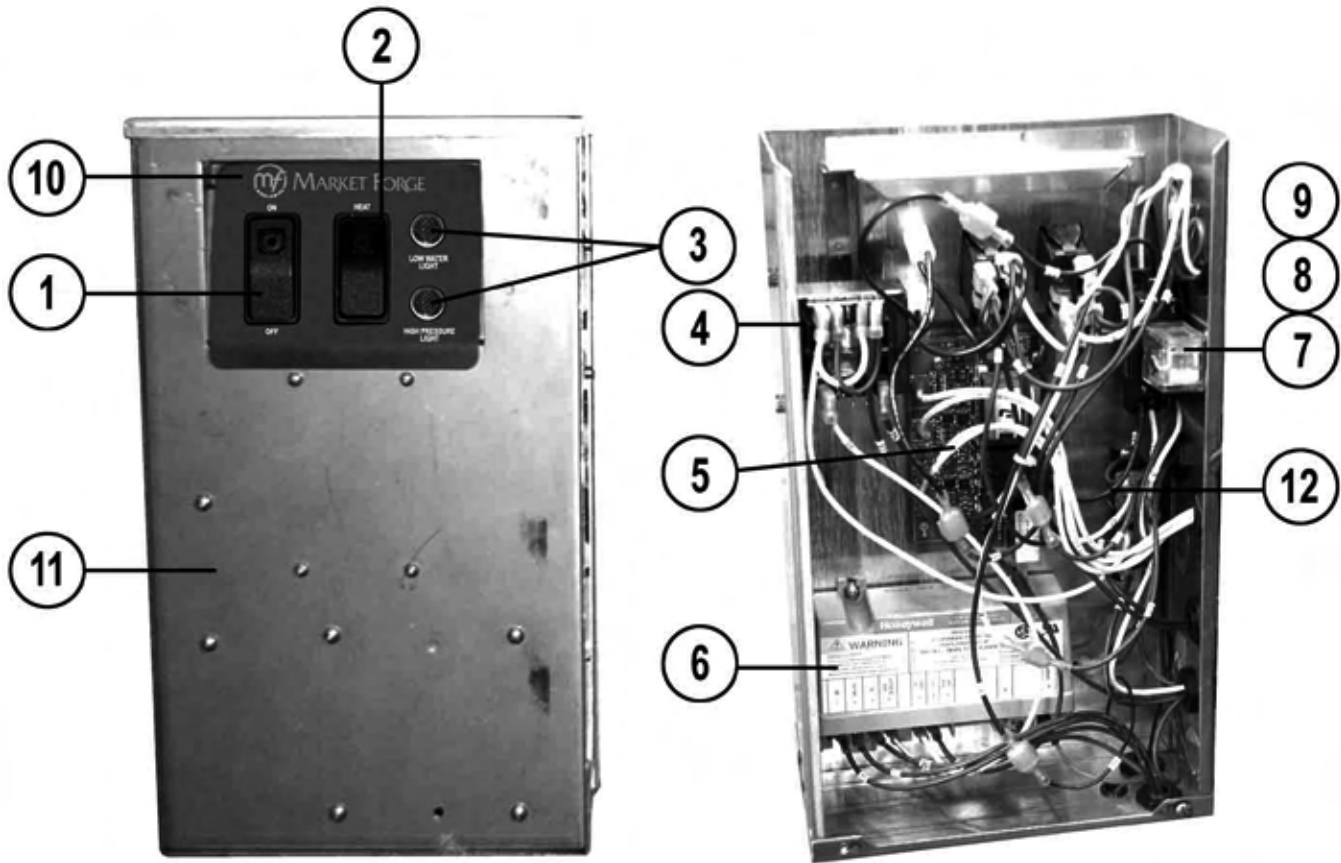

Control Box Assembly, with and without Cover

ITEM NO.	PART NO.	DESCRIPTION
1	08-6549	Switch, Power
2	94-5127	Switch, Manual Reset
3	10-5052	Light, Red
4	08-6450	Transformer, 120-240V
5	98-1680	Board, Water Level Control
6	94-5022	Ignition Module
7	08-6472	Relay Tube
8	08-6475	Relay Base
9	98-3877	Relay Bracket
10	94-5003	Artwork, Control Box
11	94-5066	Cover
12	94-5069	Terminal Strip

ILLUSTRATED PARTS LIST

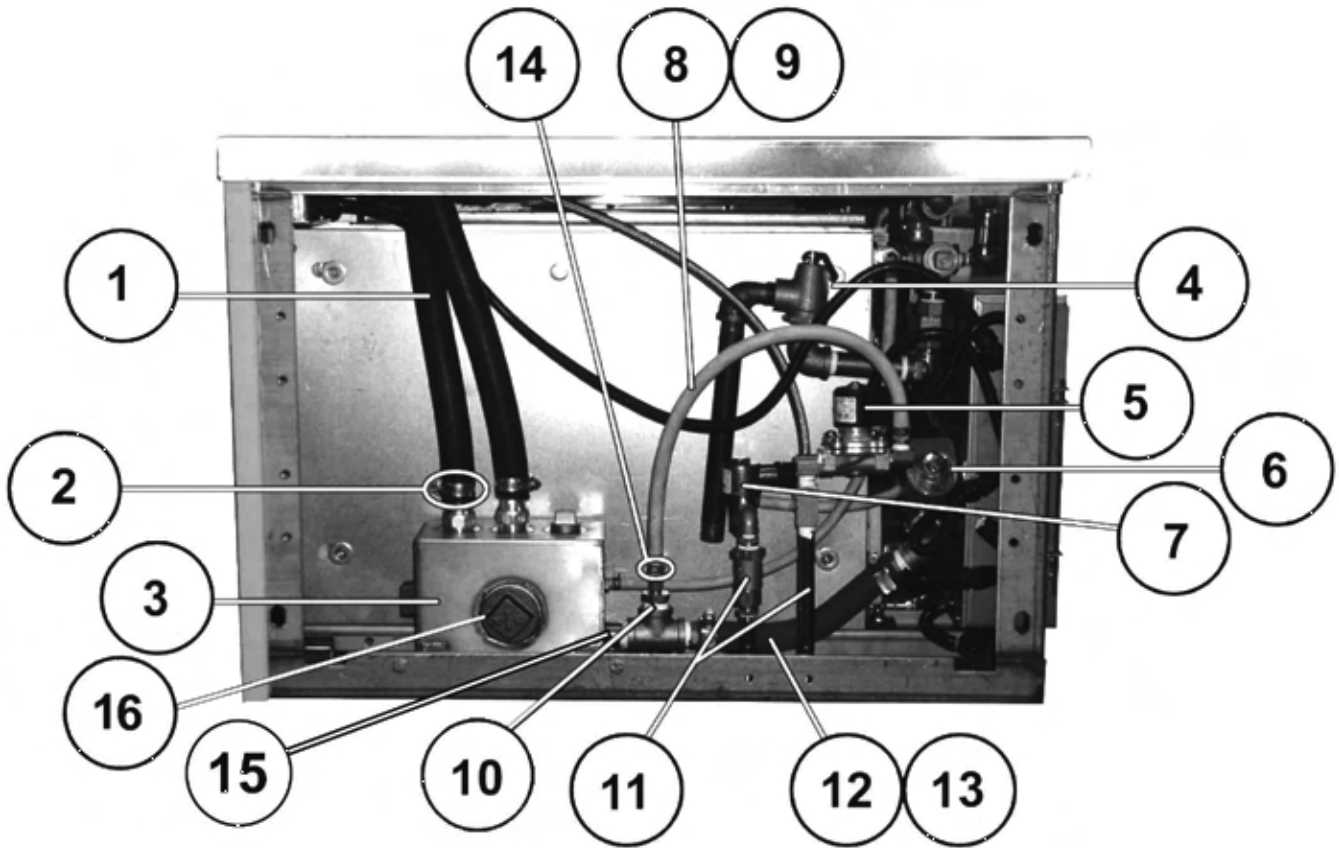

Plumbing, Left Side Gas Boiler, 24"

ITEM NO.	PART NO.	DESCRIPTION
1	10-0239	Hose, Drain 1"
2	10-4137	Clamp Hose
3	91-6927	Box Drain Assembly
4	10-7955	Valve, Safety, 15 PSI
5	10-1058	Valve, Cold Water Condenser, 120V
6	10-1311	Valve, Drain, 120V
7	08-4822	Valve, Boiler Feed
8	08-7959	Condenser, 3/8" Hose, 21" Long
9	98-3894	Copper, Nozzle
10	98-3914	Comp Fitting, 3/4"
11	98-1401	Valve, Check
12	10-0287	Hose, Drain, 3/4"
13	10-4137	Clamp, Hose
14	08-7974	Clamp, Hose
15	98-3892	Condenser Thermostat
16	10-1152	Plug

ILLUSTRATED PARTS LIST

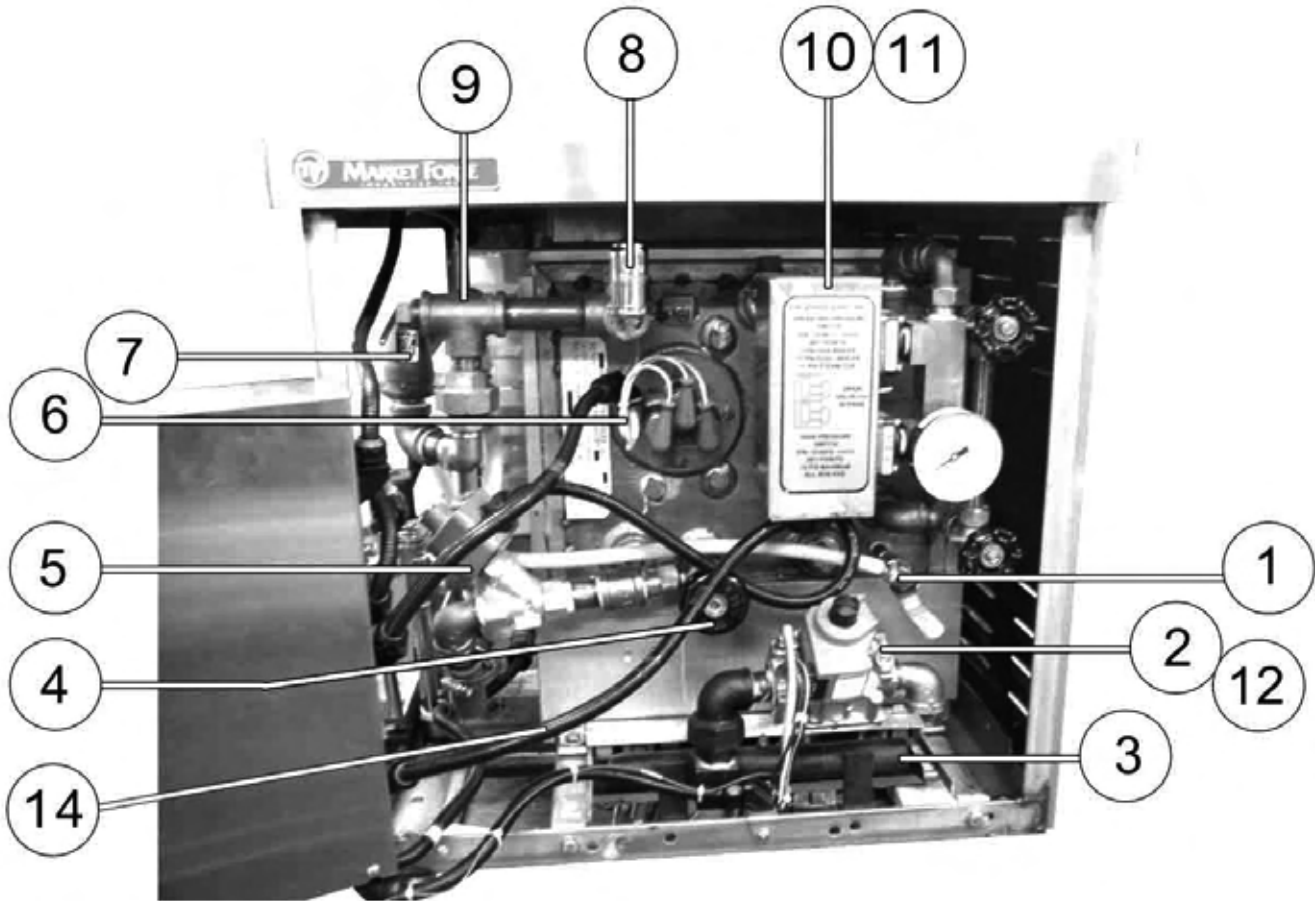

Front View Gas Boiler, 24", 200K

ITEM NO.	PART NO.	DESCRIPTION
1	08-4900	Water Inlet, Manual Valve
2	94-5023	Gas Valve
3	94-5033	Gas Manifold, 100K & 200K Boilers
3	94-5034	Gas Manifold, 300K Boilers
4	10-3661	Drain Valve, Manual
5	10-1311	Drain Valve, Automatic
6	91-5112	Probe Plate Assy
7	10-7955	Safety Valve
8	10-4556	Air Vent
9	08-4991	Tee, 3/4", Side Outlet
10	94-5065	Cover, Pressure Switch Box
11	94-5010	Label, Pressure Switch Box
12	94-5128	Gas Valve, 120V, Propane Kit
13	08-7970	Hose, Water, 20"
14	98-3864	Flex Conduite

ILLUSTRATED PARTS LIST

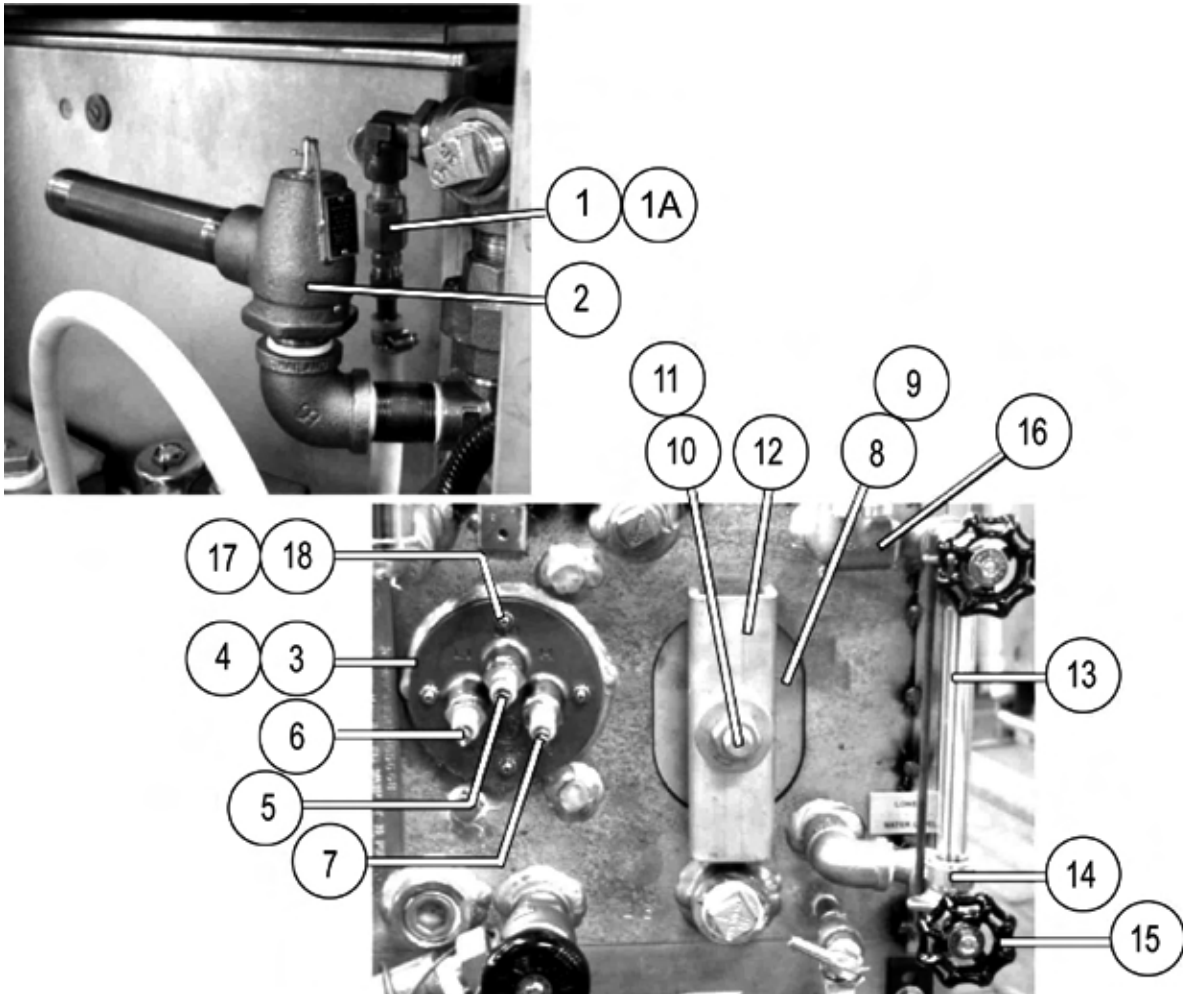

Gas Train, 200K BTU Boiler Shown

ITEM NO.	PART NO.	DESCRIPTION
1	98-3923	Vent, Bleeder
1A	08-7970	Bleeder Hose
2	10-7955	Valve, Safety, 15 PSI
3	91-7031	Probe Plate
4	08-4413	Gasket, Probe Plate
5	08-6399	Probe, Lowest Probe
6	08-6398	Probe
7	08-6364	Probe
8	91-8810	Cover Hand Hole
9	08-4415	Gasket Hand Hole
10	10-2414	Nut
11	10-2310	Washer
12	91-8811	Yoke
13	10-4754	Glass, Sight Gauge, 6"
14	90-0039	Rubber & Brass Washer Set
15	10-2728	Kit, Complete Includes: Valves, Glass
16	98-3928	Elbow 1/2", Side Outlet
17	98-3944	Stud, 1/4-20

ILLUSTRATED PARTS LIST

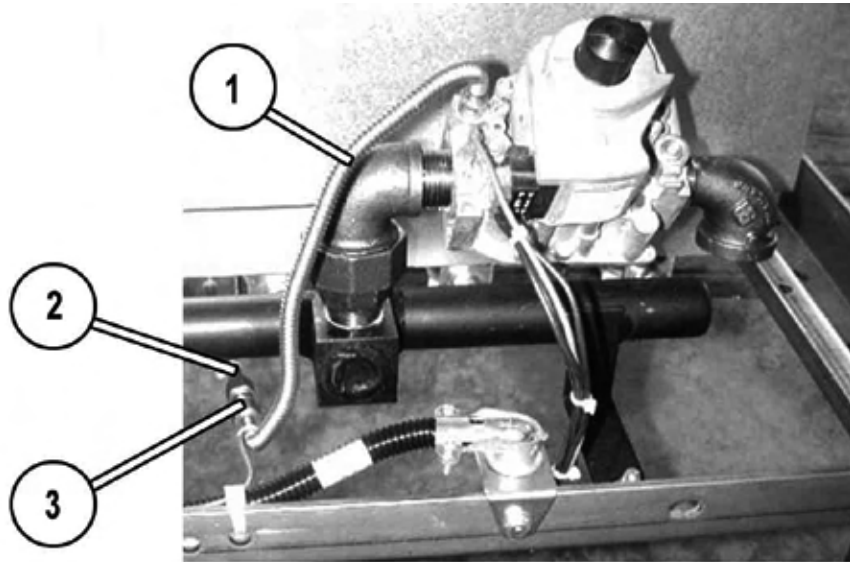

Gas Train, 200K Boiler Shown

ITEM NO.	PART NO.	DESCRIPTION
1	08-7832	Tube, Flex, Gas Line
2	10-1154	Compression Coupling
3	98-3890	Pilot Tube
4	94-5099	Spark Pilot and Igniter
5	94-5129	Pilot Orifice, Prop.
6	94-5046	Burner
7	94-5052	Pilot Brkt
8	08-7119	Orifice, Natural Gas (Brass #30)
8	08-7120	Orifice, Propane (#45 Black)
9	08-7118	Orifice Hood

ELECTRICAL INFORMATION

Wiring Diagram for New Generation Boilers - 100K, 200K and 300K BTU

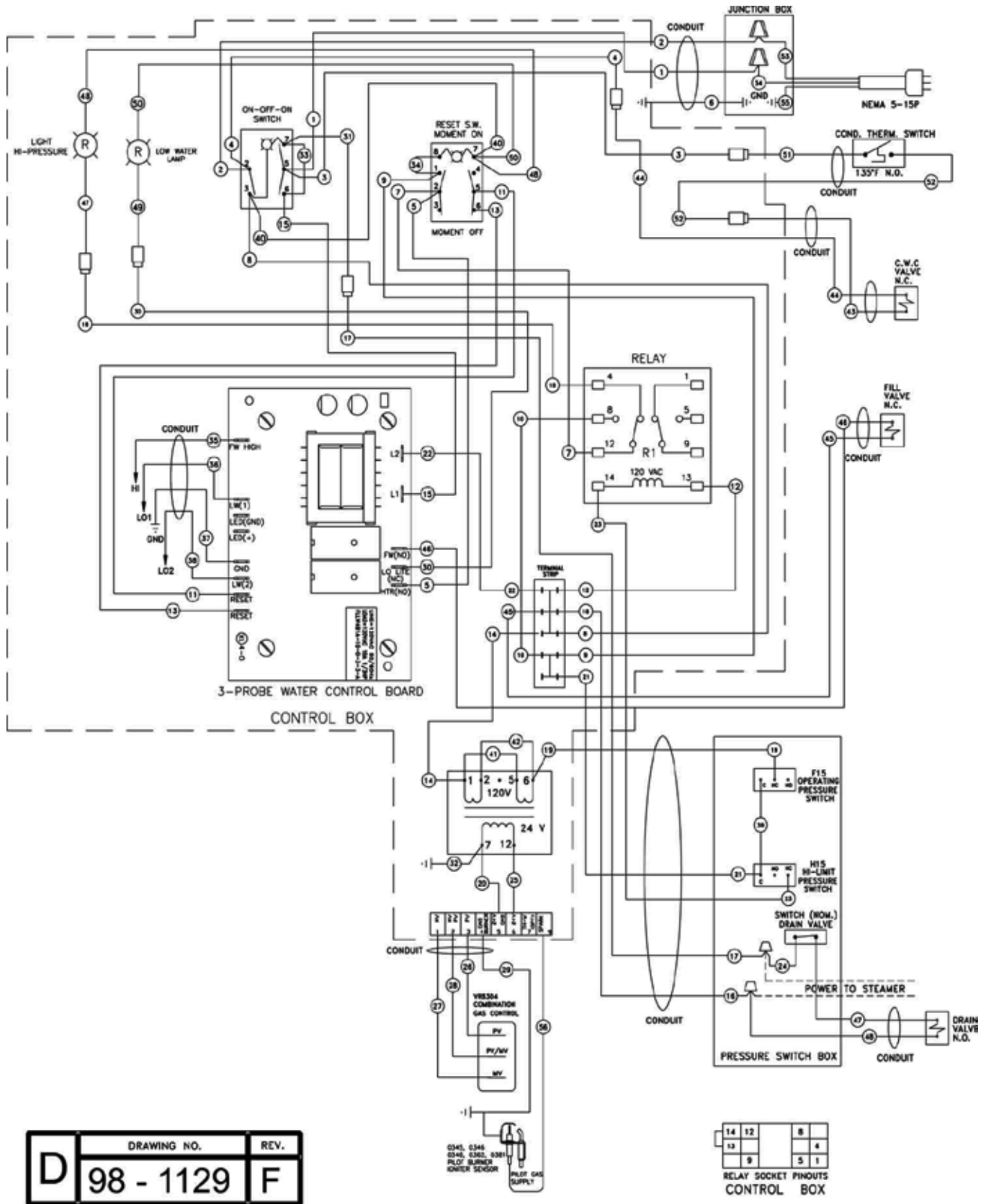

ELECTRICAL INFORMATION

Schematic Diagram for New Generation Boilers - 100K, 200K and 300K BTU

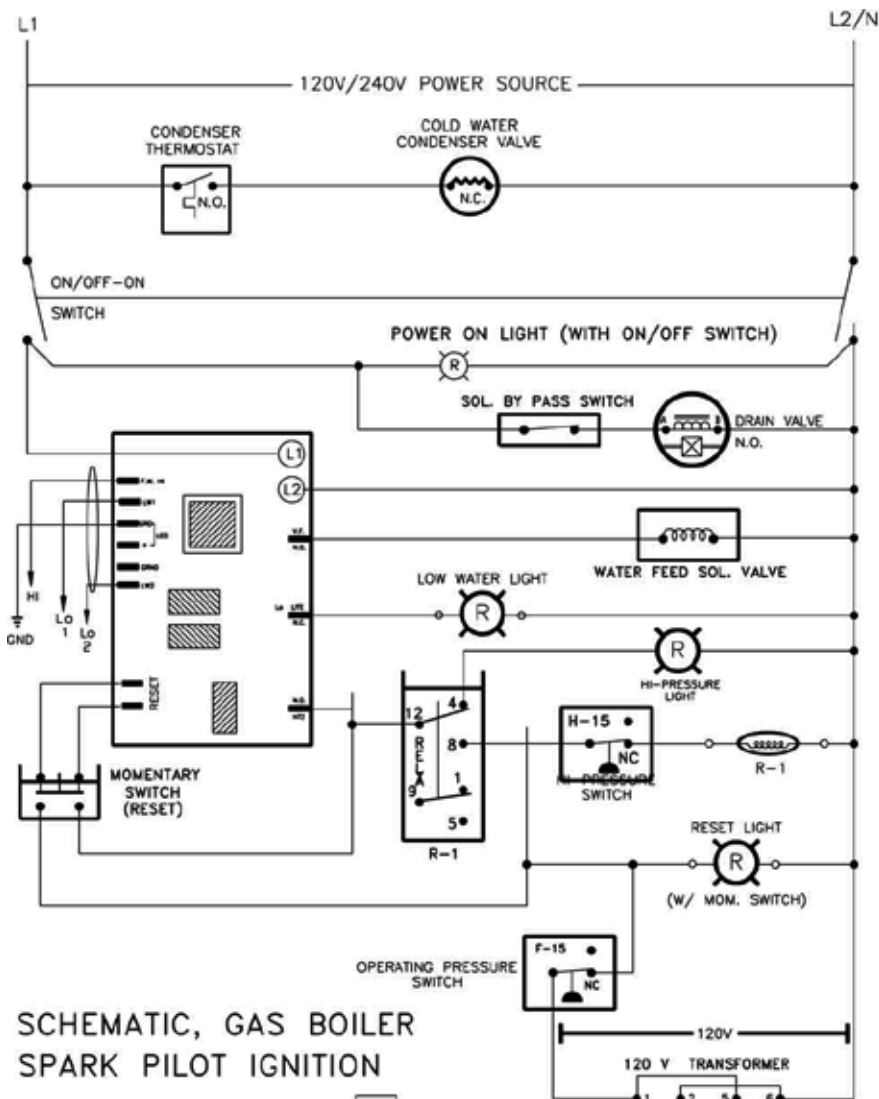

SCHEMATIC, GAS BOILER
SPARK PILOT IGNITION

D	DRAWING NO.	REV.
	98 - 1129	F

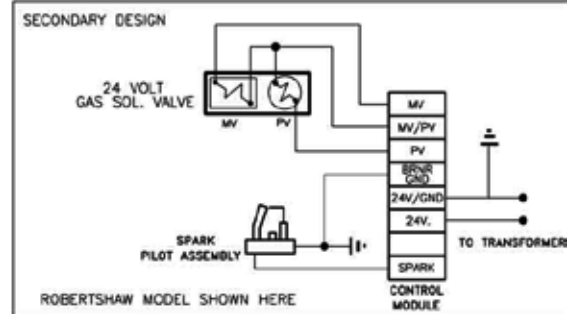
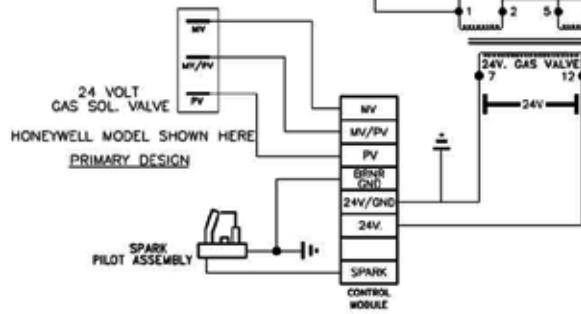

MAINTENANCE

CLEANING THE BOILER:

Market Forge recommends that the boiler be cleaned periodically due to impurities introduced through the water supply. All water supplies contain some mineral deposits and impurities, the degree varies with geographic location. Market Forge is recommending a cleaning schedule that will keep your equipment in proper, safe working order where water supplies are relatively pure. Because no water supply can be accurately compared with that of another, this section should not be regarded as fool proof. A stepped-up, more frequent cleaning schedule may be required when excessive impurities exist.

The Cleaning schedule should be performed two or more times per year as governed by the local water conditions. Market Forge recommends the use of its "cathodic descaler" to protect the inner boiler walls and components against rust, scale and lime deposits. The normal effectiveness of a descaler is one year.

The schedule for changing the "cathodic descaler" may be timed to the cleaning schedule or accelerated as noted above.

Market Forge qualified service agencies are available to establish a suitable schedule for TOTAL CONCEPT cleaning and descaler replacement.

REPLACEMENT PARTS NEEDED TO COMPLETE THESE INSTRUCTIONS

NUMBER REQUIRED	PART NO.
1 Hand-hole Cover Gasket	08-4415
1 Set of Rubber & Brass Washers	90-0039
1 Probe Plate Gasket (Gas Only)	08-4413
1 Market Forge Cathodic Descaler (all boilers) new style	08-0049
1 Dynaseal Washer	10-1135

CLEANING INSTRUCTIONS:

1. Move the HEAT and POWER switch to their OFF positions. On electric models also turn off the electric power at the main switch. This will allow the boiler to empty.

WARNING: (ALL BOILERS) DISCONNECT THE 115 VOLT POWER SUPPLY.

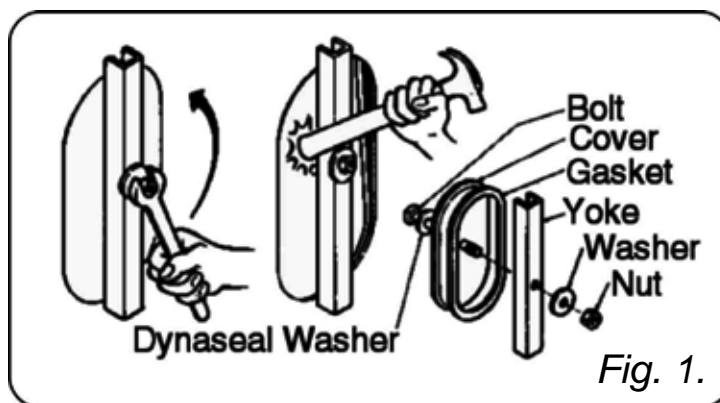

2. Remove the hand-hole cover as follows: (Refer to Fig. 1)
 - a) Remove pressure switch box at the plumbing union and move it out of the way.
 - b) With an open end wrench back off the hex-nut, counterclockwise, so only two threads are holding it. Then remove the pressure switch box and set aside.
 - c) With a blunt instrument, strike the hand-hole cover until its seal is broken.
 - d) Remove the hex-nut from the remaining two threads, slide off the washer and channel yoke do not allow the hand-hole cover to drop inside.
 - e) Remove the hand-hole cover by turning it so that it will pass through the opening. Remove the bolt and dynaseal. Discard the hand-hole gasket and dynaseal washer.

MAINTENANCE

3. Clean rust, scale and lime deposits from the inside of the boiler with a wire brush.

DO NOT DAMAGE COPPER HEATING ELEMENTS - BRUSH LIGHTLY. WORK DEPOSITS TO REAR CORNER AND REMOVE WITH PUTTY KNIFE.

4. After removing all debris, flush out with clean water through the hand-hole and drain .
5. Clean the hand-hole cover with a wire brush and wash. Be sure the areas that contact the gasket and dynaseal are clean and smooth.

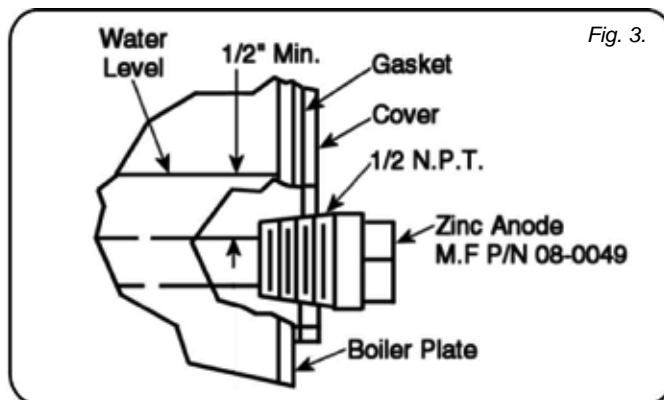
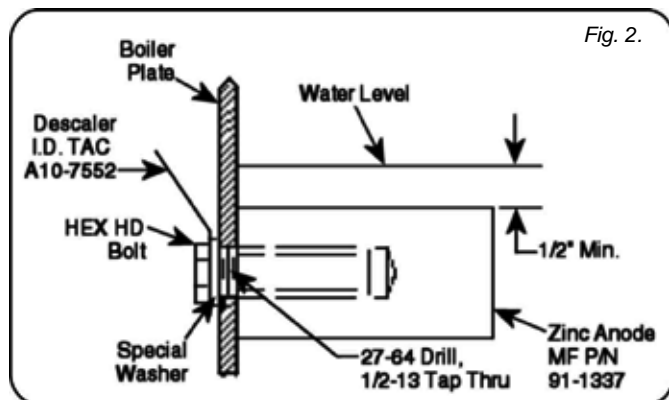

6. To protect against further scale and corrosion remove the old cathodic descaler. Install a New Market Forge Cathodic Descaler. See fig. 2 or 3, page 43.
7. Without the use of gasket compound, re-install the handhole cover using a new gasket and dynaseal washer. A torque of approximately 50 in. lbs. is required to reset the hex nut. Reinstall the pressure switch box. Bring the boiler to operating pressure. If a leak appears, at the handhole cover, relieve the pressure in the boiler and retighten the hex nut.
8. Clean the water gauge glass as follows:
 - a) Move the heat and power switch to their off positions. This will allow the boiler to empty.
 - b) Unscrew the fittings from both valves and slide them toward the center of the gauge glass. Push the water gauge glass downward compressing the rubber washer in the lower valve allowing the glass to be removed.
 - c) Remove and discard the two rubber and brass washers. Slip off the two valve fittings and clean the water gauge glass.
 - d) Reassemble by reversing the above steps with new rubber and brass washers . (see fig. 4)

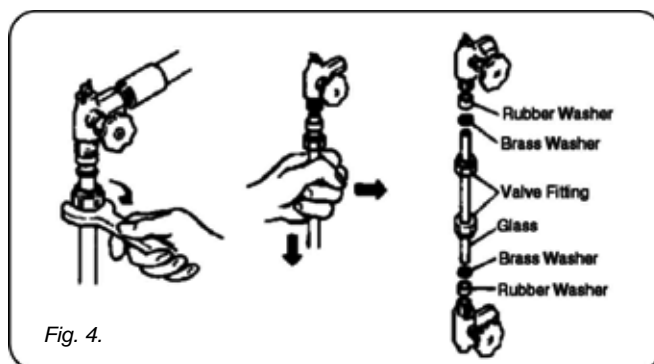

APPLICATION INSTRUCTIONS

S-2299

APPLICATION INSTRUCTIONS FOR TOTAL CONCEPT CLEANING OF BOILER SIZE: 1 Gallon PART NUMBER: 20 - 0307

GENERAL NOTES:

Market Forge R has two basic types of boilers; one has an automatic drain valve, the other has a manual drain valve. To determine which type you have, open cabinet doors and you will see a control box with two switches and an indicator light. The instruction label on the control box will identify the boiler as being either automatic or manual. Those boilers designated as being automatic must be energized in order to close the drain valve.

Total Concept is designed to be used with water between 160°F to 200°F.

Preheating is required on both automatic and manual boilers to raise the water temperature to the acceptable range. (160°F to 200°F).

For manual boilers, make certain drain valve is tightly closed.

On Market Forged boilers manufactured after 8/84; your unit is equipped with an access plug in the steam header line. This location should be used to add cleaner/descaler to boiler chamber during maintenance.

On Market Forged boilers manufactured before 8/84; access to boiler chamber should be gained through either the vent-rite or the pressure relief valve.

Total Concept is a NSF listed nonfood product. This is a liquid acid (nonmuriatic) product that works without fumes, odors, and hazards associated with other harsh chemicals.

BOILER TREATMENT CLEANING INSTRUCTIONS:

After determining proper location for cleaner/descaler to be added: Read complete instructions thoroughly; including all warning and cautionary statements.

Fig. 1



1. Energize boiler and fill to operating level.

Fig. 2



2. Energize heating circuit to pre-heat unit.

Fig. 3



Fig. 4

3. AUTOMATIC - After unit is pre-heated, cycle the power switch to the OFF position then immediately back to the ON position.

APPLICATION INSTRUCTIONS

S-2299

APPLICATION INSTRUCTIONS FOR TOTAL CONCEPT CLEANING OF BOILER SIZE: 1 Gallon PART NUMBER: 20 - 0307

Fig. 5



4. Remove the shipping cap, replace it with the pouring cap. Cut the tip of the pouring cap at the first notch to a 45° angle.
5. Install the tubing firmly over the tip of the pouring cap.

Fig. 6



6. Energize compartment to release steam pressure in boiler to "0" PSI before removing pipe plug.
7. Remove the plug from the access port on the steam header pipe inside cabinet doors.

CAUTION: HE7DER PIPE & ACCESS PLUG ARE HOT.

Fig. 7

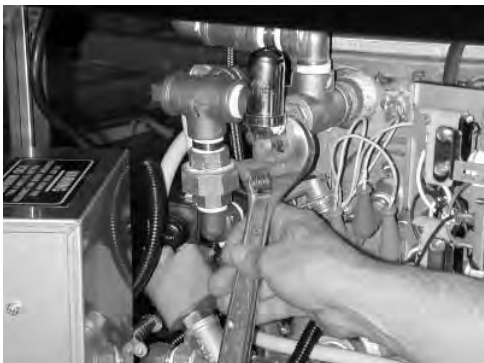

Fig. 8



8. Feed the tubing through the access port in the boiler compartment.

NOTE: A minimum of 12" must be inserted.

Fig. 9

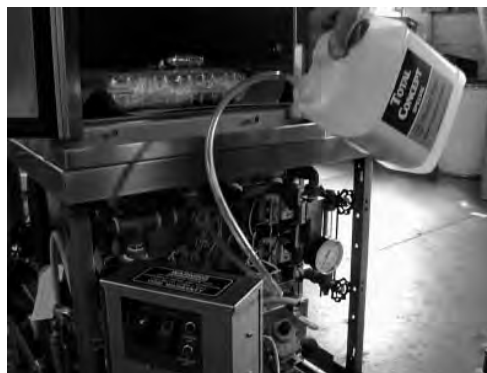

9. Tilt the container, pour the contents into the unit.
10. When empty, refill the container with hot tap water and add to boiler for cleaning. Repeat twice. This additional 2 gallons of water will cause the low water probe to be immersed in cleaner/descaler solution. Replace access plug.
11. After rinsing the container, place tubing inside the bottle, cover with shipping cap, dispose of properly. DO NOT REUSE CONTAINER.
12. DO NOT ENERGIZE HEATERS. Allow 2 hours for cleaning.
13. After time has elapsed, drain the boiler.
14. Refill the boiler and drain. Repeat this step twice.
15. Bring the boiler to temperature and cycle steam to the cooker compartment to purge cleaner/descaler from the steam supply lines. Repeat this step twice.
16. Boiler is now ready for use.

