



MARKET FORGE

STERILMATIC ANALOG ELECTRIC STERILIZER PARTS AND SERVICE MANUAL

EFFECTIVE JULY 19, 2017

Superseding All Previous Parts Lists.

The Company reserves the right to make substitution in the event that items specified are not available.

ERRORS: Descriptive and/or typographic errors are subject to correction.

MARKET FORGE

Telephone: (802) 658-6600 Fax: (802) 860-3732

www.marketforge.com

P/N 14-0412 Rev F

TABLE OF CONTENTS

DOOR ASSEMBLY & ADJUSTMENT	3
FULCRUM AND DRAIN ASSEMBLY	5
PRESSURE ACTUATED TEMPERATURE CONTROL.....	6
MISCELLANEOUS COMPONENTS	8
TROUBLESHOOTING.....	10
ILLUSTRATED PARTS LIST	11

DOOR ASSEMBLY & ADJUSTMENT

STERILMATIC DOOR ASSEMBLY

The Door of the Sterilmatic has been engineered to establish a positive method of sealing the steam pressure within the sterilizing cylinder. As steam pressure builds up within the cylinder, the door seal will tend to become more positive.

However, the door should be adjusted to make a good initial seal between the door gasket and the door opening without the added assistance of internal cylinder steam pressure with the simple action of securing the door handle down in a locked position, the door gasket should be sufficiently compressed against the door opening, all the way around to prevent any steam leakage from occurring.

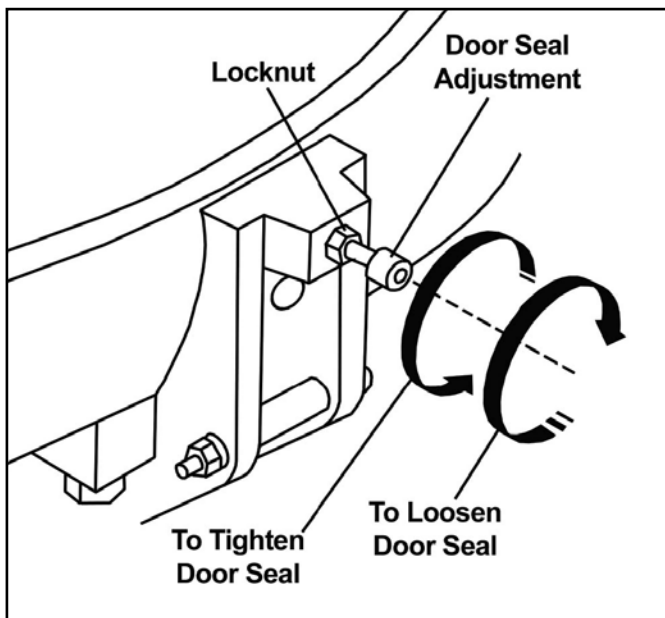

Figure 1

DOOR ADJUSTMENT

The Door Adjustment is Located in the Fulcrum Casting at the base of the door opening. This adjustment employs the use of a screw and locknut in order to adjust the Sterilmatic Door to a tighter closed position (to prevent steam from leaking by the door gasket as pressure builds up), it is necessary to loosen the locknut and back off the screw at least one-quarter of a turn and re-tighten the locknut.

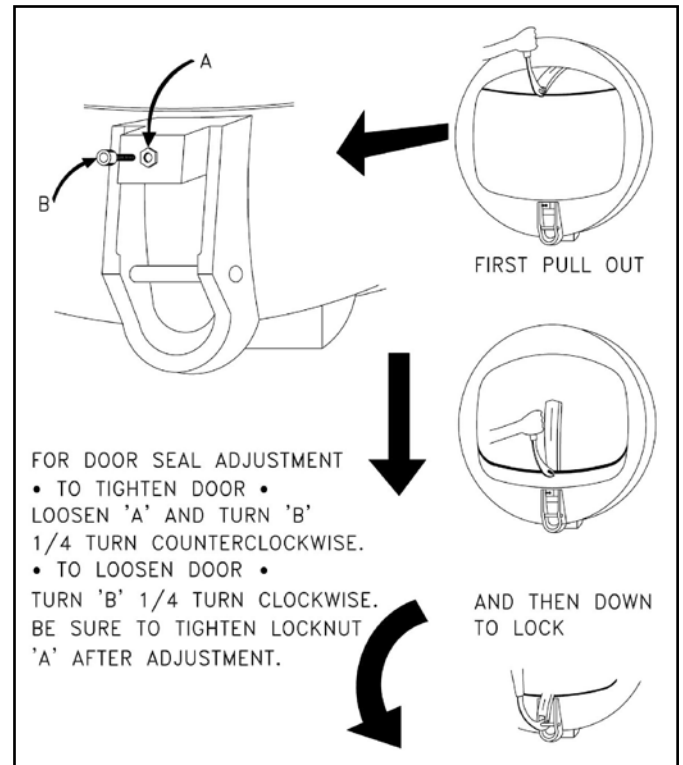

Figure 2

THE DOOR GASKET

Keep the gasket clean. With normal closing and locking of the door assembly, a steam-tight seal should be made between the door gasket and the door opening. This seal cannot be maintained if particles of foreign matter are allowed to accumulate upon either of the contacting surfaces.

If there is leakage by the door gasket before a steam build-up within the steam chamber and leakage does not stop when the sterilizer reaches sterilizing temperature and pressure than regard the door assembly as improperly adjusted. A re-adjustment must then be made of the seal adjustment door screw.

To change the door gasket, remove the entire door assembly as a unit. Discard the old gasket, replace it with a new one (no cement is required), and reinstall the door assembly. Make an operational check for leakage and adjust the door, if necessary.

DOOR ASSEMBLY & ADJUSTMENT

DOOR LIFT SPRING

Market Forge supplies door lift springs in sets only. This policy has been found to be in the best interest of the customer. Through continuous use, some of the original qualities of the springs are lost and it becomes advantageous to make replacements to both the left and right door lift springs in the event that one becomes damaged or broken.

Replacement door lift springs are marked with tabs at the factory prior to shipment to identify a right from a left spring. These springs must be installed with the right door lift spring on the right of the door and the left door lift spring on the left of the door as viewed from the front of the sterilizer.

TO REMOVE THE DOOR ASSEMBLY

The Door Assembly can be removed from the inner sterilizing chamber as a unit without the use of any special tools or equipment. However, a systematic approach to this is warranted as the clearances through the portal are close, and much confusion can result if not removed in the sequence described below:

1. First, lift off and remove the two pan supports to expose the door linkage on either side of the inner sterilizing chamber .
2. Raise the door to a fully opened position, and disengage the door spring from each of the door spring studs. Accomplish this by counteracting the force of the door lift spring with one hand while working the end of the door spring off the spring stud with the free hand. Do this on both sides of the door assembly.
3. When the end of the door springs have been completely freed from their respective door spring studs, the door springs on either side of the door assembly can easily be slipped off their studs.
4. Rotate the entire door assembly out through the door opening, passing the door handle through the opening first, and then one end of the door spring as shown in the illustration. The remainder of the door assembly will then pass through the door opening quite easily.
5. To replace the door assembly, reverse the step-by-step procedure described above.

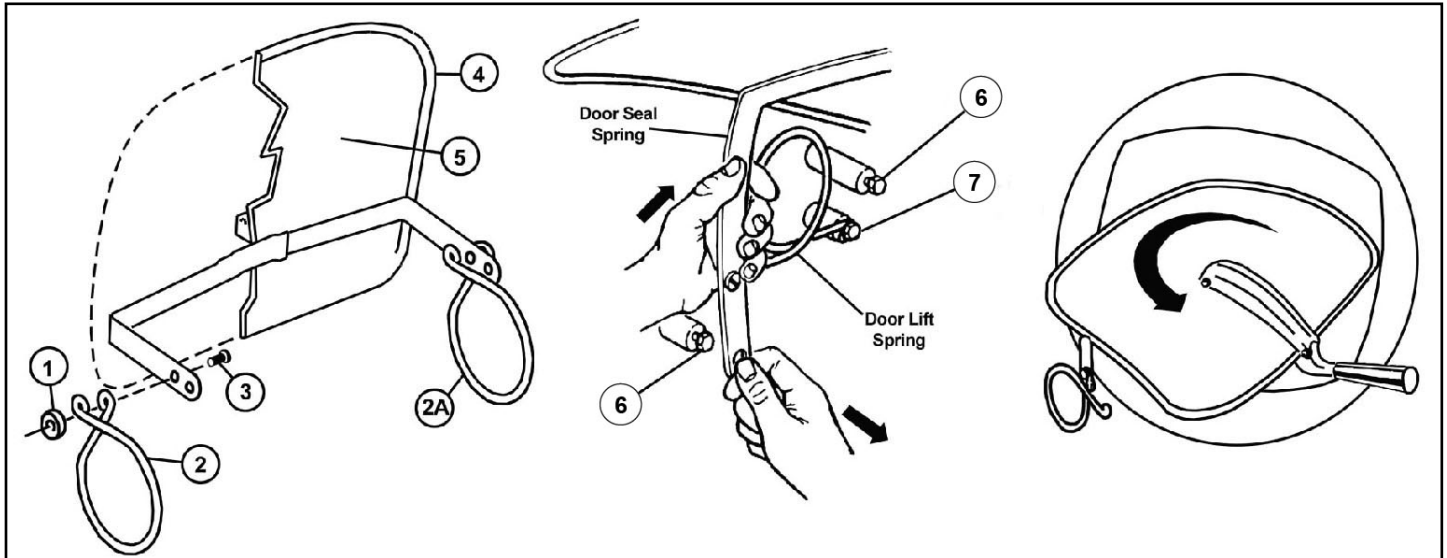

Figure 3

ITEM	PART NO.	DESCRIPTION
1	10-6765	Pivot Spring Bearing
2	91-2718	Right and Left Door Spring (sold as a pair)
3	10-1776	10-32 Machine Screw 1/2" Long
4	10-2666	Door Gasket
5	95-3204	Door & Door Spring Assembly
-	95-0124	Items 1 through 5

FULCRUM AND DRAIN ASSEMBLY

THE FULCRUM & DRAIN ASSEMBLY

The fulcrum and drain assembly is located at the lower front of the sterilizing chamber and furnishes a sturdy anchorage for the door locking system of the door handle. Also provided in this assembly is a means for adjustment of the door seal. The drain port and drain valve provide a means of discharging accumulations of water from within the sterilizing chamber.

ROLLER ASSEMBLY (ITEMS 8 & 9)

The Roller Assembly must be kept free-rolling at all times. Should this assembly be allowed to become frozen due to lack of lubrication, undue strain will be put on the door handle and the fulcrum casting while the door is being locked. Use only a dry lubricant such as graphite; as oil or grease will tend to attract dirt to this area.

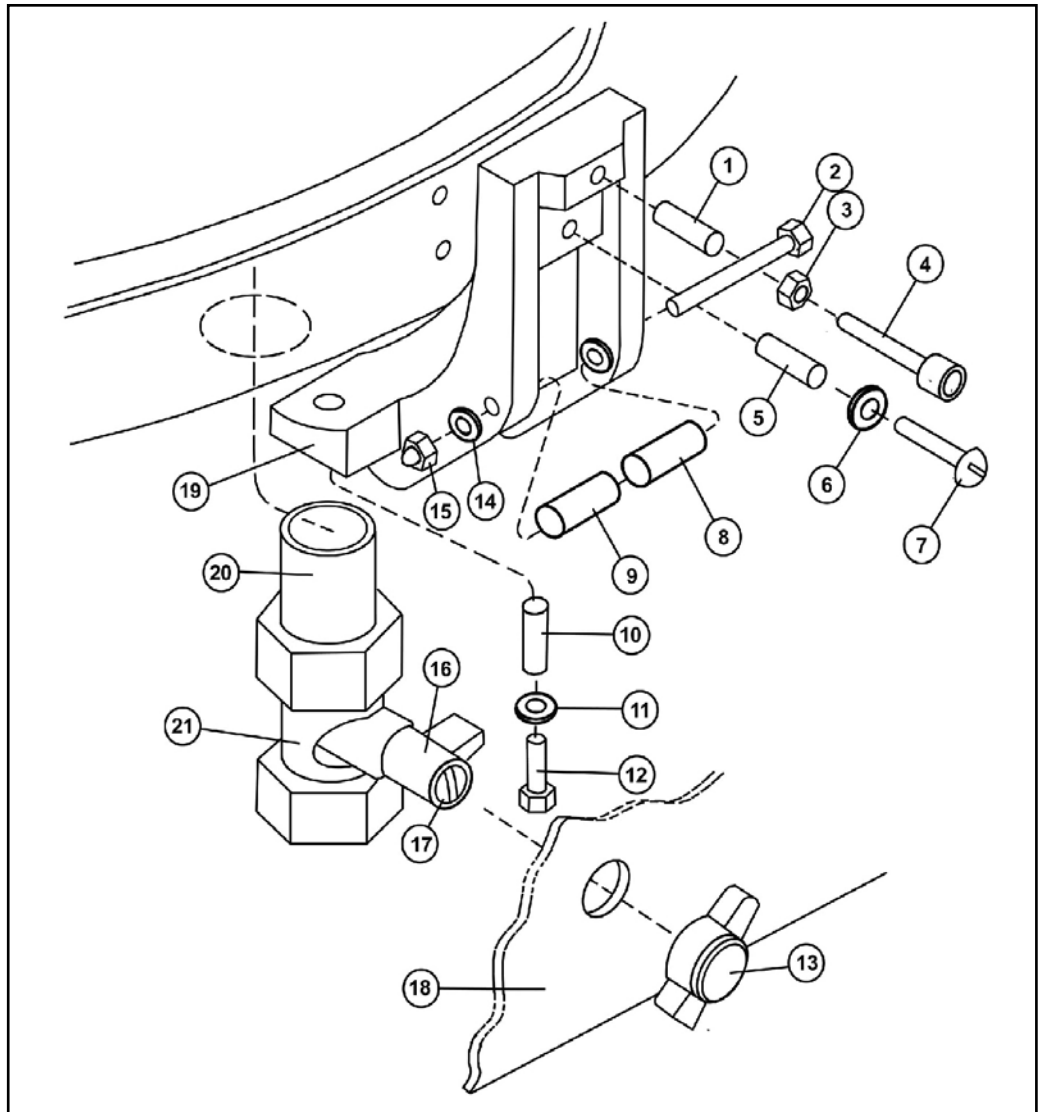

Figure 4

ITEM	PART NO.	DESCRIPTION
1	10-3116	1/4" - 20 X 5/8 helicoil
2	10-1999	10-32 Machine screw, 1 5/8" long
3	10-2358	1/4" - 20 fulcrum nut
4	10-2087	1/4" - 20 allen set screw
5	10-3111	1/4" - 20x 3/8 helicoil
6	10-2513	1/4" Shakeproof washer
7	10-1763	1/4" - 20 Machine screw 3/4" long
8	95-0120	Bearing spacer
9	95-0198	Bronze Bearing
10	10-3111	1/4" - 20 x 3/8 helicoil
11	10-2513	1/4" Shakeproof washer
12	10-1790	1/4" - 20 Cap screw 7/8" long

ITEM	PART NO.	DESCRIPTION
13	10-4485	Drain valve knob
14	10-2514	#10 Shakeproof lockwasher
15	10-2318	10-32 acorn nut
16	95-2643	Adapter - steinball valve
17	10-1950	6-32 Round head screw 1 5/8" long
18	98-4372	Front outer case lower
19	95-3850	Fulcrum and drain casting
20	10-1049	Nipple 1/2" IPS 2 1/4" long stainless steel
21	10-1041	Ball valve stein
-	95-3992	Fulcrum and drain assembly, Items 1 through 12, 14, 15, and 19

PRESSURE ACTUATED TEMPERATURE CONTROL

STM-E AND STM-EL

The pressure actuated temperature control, located behind the control panel assembly, governs the manufacture of steam by controlling the input of electric current to the heating elements.

HOW IT WORKS

When the Timer is set, rear and front contactors will become energized allowing input of current to the temperature control, thus closing the contacts completing the current to the heating elements. Steam will then be generated within the sterilizing chamber.

The steam pressure within the sterilizing chamber is transmitted by means of a tube to the bellows of the temperature control; as the steam pressure increases, its compression action on the bellows is set to cause the Switch #1 on the control to cut out on rising pressure at 13.5 PSI and to cut in on falling pressure at 13 PSI (controlling the two outer banks of heating elements). Switch #2 is set to cut out on rising pressure at 15.5 PSI and cut in on falling pressure at approximately 15 PSI (controlling center heater element only).

Thus, a balancing effect of steam pressure build-up and heater element current is constantly maintained during the sterilizing cycle. When the Timer signifies the end of the cycle, the electric current to the contactors will automatically be broken; the temperature control contacts will be broken; and steam generation will stop.

ADJUSTING THE RANGE OF OPERATION, STM-E

NOTE: These instructions should be performed by qualified service personnel only.

The operational range of the temperature control is factory set as follows: Outer bank of elements OFF at 13.0-13.5 PSI; Center bank of elements OFF at 15.5- 15.0 PSI; minor compensating adjustments can be made by turning the adjusting screws counter-clockwise to increase pressure and clockwise to decrease pressure. Both screws should be turned the same amount when making an adjustment.

NOTE: When resetting this control for elevations above sea level a correction of 6/10 lb. per thousand feet is necessary.

1. Before making adjustments, shut all electrical current to the sterilizer OFF to eliminate shock hazard.
2. Remove the Flue Cover.
3. Make sure that all exposed wires are not in a hazardous position, and then turn on electrical power.
4. Run unit through cycle, observing pressure and temperature gauges, turn adjusting screws as required.

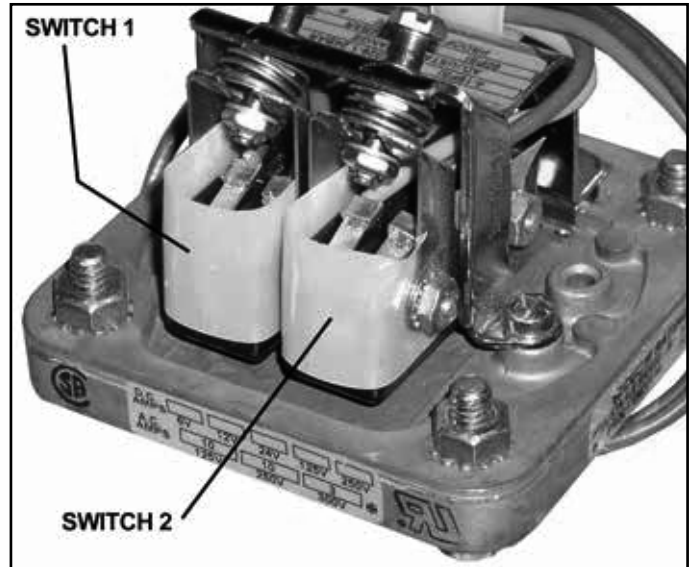

Figure 5

CHECKING THE 230° SETTING, STM-EL

The Unit should be completely evacuated then temperature selector dial should be turned on 230° Fahrenheit. Observe the current until it takes a sharp drop to approximately one-third of the full load; at this instant, there should be a corresponding chamber pressure of 2 PSI

Observing the current further will show another sharp drop to approximately 2 Amps; at this instant, there should be a corresponding chamber pressure of 6.1 PSI and a temperature reading of 228° to 232° Fahrenheit, on the temperature gauge.

ADJUSTING THE RANGE OF OPERATION STM-EL

The range of operation of Model STM-EL is adjusted by simply turning the adjusting knob on the outside of the Control Panel. A counter-clockwise turn decreases the pressure while a clockwise turn increases the pressure. Observe pressure and temperature gauges and adjust knob as required.

NOTE: When resetting this control for elevations above sea level, a correction of 6/10 lbs. per thousand feet is necessary.

PRESSURE ACTUATED TEMPERATURE CONTROL

STM-EX AND STM-ELX

The pressure actuated temperature control, located behind the control panel assembly, governs the manufacture of steam by controlling the input of electric current to the heating elements.

HOW IT WORKS

When the timer is set, rear and front contactors will become energized allowing input of current to the temperature control, thus closing the contacts completing the current to the heating elements. Steam will then be generated within the sterilizing chamber.

The steam pressure within the sterilizing chamber is transmitted by means of a tube to the bellows of the temperature control; as the steam pressure increases, its compression action on the bellows causes the contacts to make or break according to the condition of the pressure at that time (*rising or falling*).

Switch #1 on the control is set to cut out on rising pressure at 0.95 kg/cm² and to cut in on falling pressure at 0.91 kg/cm² (controlling the two outer banks of heating elements). Switch #2 is set to cut out on rising pressure at 1.09 kg/cm² and cut in on falling pressure at approximately 1.05 kg/cm² (controlling center heater element only).

Thus, a balancing effect of steam pressure build-up and heater element current is constantly maintained during the sterilizing cycle. When the Timer signifies the end of the cycle, the electric current to the contactors will automatically be broken.

CHECKING THE 110°C. SETTING, STM-ELX

The Unit should be completely evacuated then temperature selector dial turned to 110°C Centigrade. Observe the current until it takes a sharp drop to approximately one-third of the full load; at this instant, there should be a corresponding chamber pressure of 0.14 kg/cm².

Observing the current further will show another sharp drop to approximately 1 Amp; at this instant, there should be corresponding chamber pressure of 0.43 kg/cm² and a temperature reading of 110°C Centigrade, on the temperature gauge.

ADJUSTING THE RANGE OF OPERATION, STM-ELX

The range of operation of Model STM-ELX is adjusted by simply turning the adjusting knob on the outside of the Control Panel. A counter-clockwise turn decreases the pressure while a clockwise turn increases the pressure. Observe pressure and temperature gauges and adjust knob as required.

NOTE: When resetting this control for elevations above sea level, a correction of 0.13 kg/cm² per kilometer elevation is necessary.

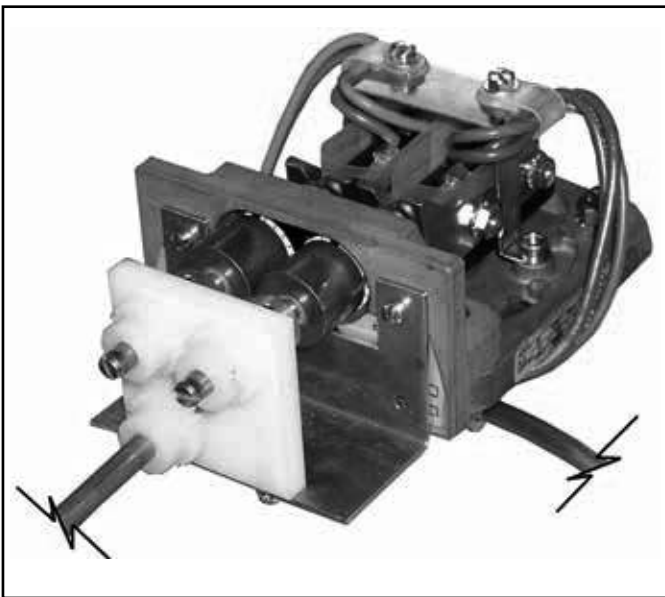

Figure 6

MISCELLANEOUS COMPONENTS

CAST-IN HEATING ELEMENTS

Located under the sterilizing cylinder is a bank of (3) U-shaped heating elements. These elements are welded in place in a protective aluminum shield. The elements cannot be removed, and in the unlikely event that one or all fail, the complete cylinder must be replaced.

THE LOW WATER CUT-OFF (MANUAL RESET)

Fastened to a special mounting brace behind the front panel, the Low Water Cut-Off acts to shut off the complete unit, should the water run dry. The Low Water Cut Off is factory set, to shut the unit off when the cylinder temperature rises between 380° and 440° Fahrenheit.

When the Sterilmatic is turned on without water or the water has been evaporated away, the temperature of the aluminum sterilizing cylinder will rise and by heat induction effect the Low Water Cut-Off. Its inner electrical contacts will be forced open from heat expansion, thus cutting off the flow of electric current to the heating elements. With the replacement of water into the cylinder the cylinder temperature will drop and the contacts of the Low Water Cut-Off can be again closed. The unit will only restart after the manual button has been re-set.

THE ELECTRIC CONTACTORS

The Electric Contactors are located on the top of the unit, underneath the top flue cover. These important components receive an electrical impulse when the Timer is turned on. When the unit reaches a pre-set pressure of 13-13.5 PSI the #1 switch will cut out causing the front contactor to become de-energized. This, in turn, will disconnect the left and right bank of heaters and the timer motor will start.

THE TIMER

The Sterilmatic is put into operation with the manual setting of the timer. With the setting of the timer, an electrical current is directed to the pressure control. The current energizes the pressure control, which activates the contactor coils to cause a current flow to the heating elements. When the cylinder pressure reaches 13 to 13.5 PSI, the timer motor and pilot light are energized. At the end of the cycle the timer will cut off the flow of electricity to all the components except the exhaust, the exhaust solenoid and the timer motor. They will revert back to their original deactivated state. The timer motor and pilot light will continue to be energized after the timed sterilizer cycle has been completed and for two additional minutes. Only after this will the timer and white pilot light be de-energized. If the timer fails to operate the Sterilmatic, replace it. The timer is replaceable only as a complete unit as factory repairs to it would not be practical in the economical interests of the customer.

THE STEAM PRESSURE GAUGE

The Steam Pressure Gauge registers the pressure of steam, which is within the sterilmatic sterilizing chamber. To replace this unit, it is necessary to disconnect the copper tubing and to remove the two nuts holding the gauge framework in place.

THE SAFETY VALVE

The Safety Valve is factory set to automatically open and exhaust excess steam from within the sterilizing cylinder, thereby assuring that operating pressures remain within safe limits. The lever action of the safety valve must be free to operate unrestricted at all times. If the Safety Valve should leak continually with a pressure build-up or should it cause an interruption on a sterilizing cycle prematurely (below 124° Centigrade on the temperature gauge), it must be replaced. However, the temperature gauge should first be checked for accuracy.

THE FLUE

The Flue serves as a protective shield for the steam trap safety valve, exhaust valve, and electrical components as well as a mounting base for the control panel. The pressure gauge, dial thermometer, exhaust valve switch and timer, protrude through the control panel. The Flue cover may be removed to allow more room for servicing the control components. The control panel face may then be removed by unscrewing the sheet metal screws, which mount it to the Flue.

THE EXHAUST SOLENOID VALVE

The exhaust solenoid is normally closed and only opens at the end of the cycle when it is energized.

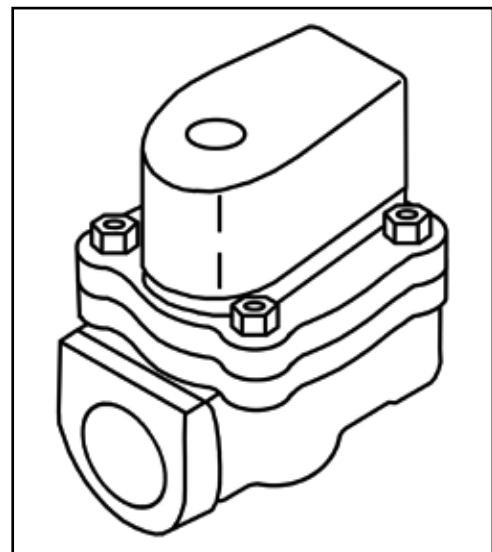

Figure 7

MISCELLANEOUS COMPONENTS

TO REPLACE A THERMOSTATIC ELEMENT:

1. Remove the cap of the steam trap (turn it counter-clockwise).
2. Unscrew the diaphragm and seat and discard.
3. Wipe all dirt and scale from the inside of the steam trap.
4. Place a new diaphragm and seat securely into the steam trap and replace the cap (New Style - Part No. 98-1719).



Figure 8

THE STEAM TRAP

The Steam Trap has the very important automatic, dual function of exhausting all air from the sterilizing compartment, and of making a suitable seal to allow a pressure build-up of live steam during a cycle of sterilization. Also, a slot is milled at an angle through the seat to allow a constant bleed-off of a slight amount of steam during the cycle to completely eliminate any air pockets in the cylinder. Failure of the trap to operate properly will result in an uneven distribution of live steam within the compartment.

How it works

With the introduction of steam into the sterilizing compartment, cold air will escape. When sufficient generated steam displaces the cold air, it will then start to exhaust through the steam trap to heat the thermostatic element. The expansion of the thermostatic element will make a seal against the seat to enclose the live steam within the sterilizing compartment and a steam pressure build-up will occur.

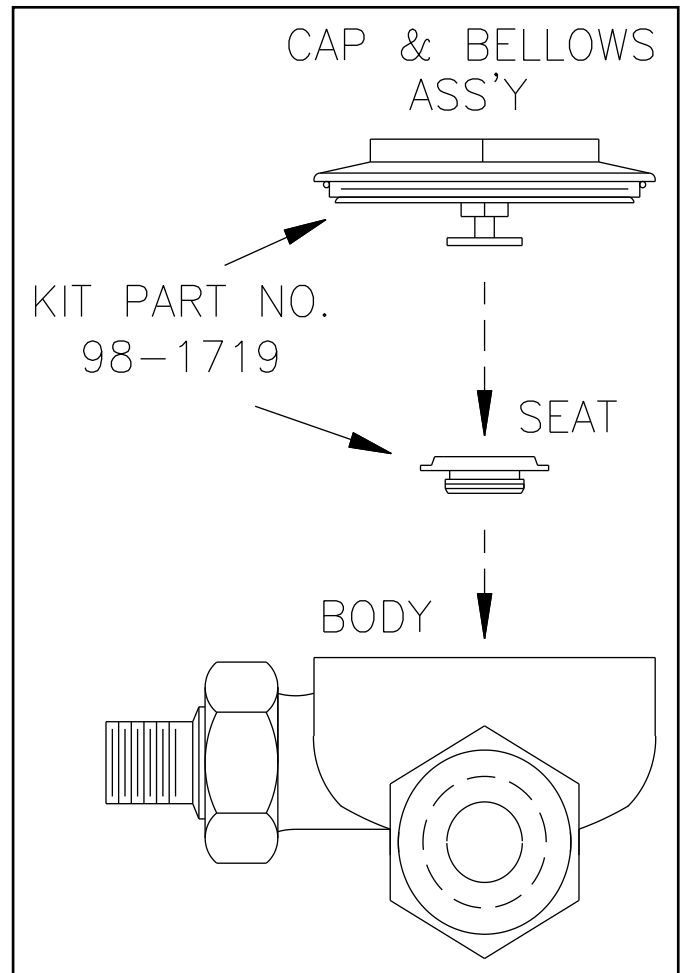

Figure 9

TROUBLESHOOTING

STEAM TRAP TROUBLE-SHOOTING

Trouble can only occur either through the premature closing of the steam trap before all the cold air has been exhausted, or by its failure to close sufficiently to enable a proper steam pressure build-up. Either case warrants a replacement of the thermostatic element.

TROUBLE	POSSIBLE CAUSE	CORRECTION
Sterilizer fails to operate at all (<i>no pressure build up</i>).	<ol style="list-style-type: none"> Not installed correctly. Blown fuse. Contactors burned out. Wiring is defective. 	<ol style="list-style-type: none"> Check wire diagram for correct hook up. Replace fuse. If it blows, check that source of electric supply is 60 amps. Replace. Check all wiring. Repair or replace.
Sterilizer operates, but fails to build up 15.5 PSI pressure.	<ol style="list-style-type: none"> Current not heating all of the elements. Steam trap fails to close. Exhaust valve fails to hold pressure at 15.5 PSI. Steam leaks around door. Safety valve blows-off prematurely. 	<ol style="list-style-type: none"> Remove lower front panel and see if the heating elements are working. Replace the thermometer within the steam trap. Check for incorrect adjustment on temperature control. Readjust. Check for worn gasket or make door adjustment. Replace safety valve.
Unit releases pressure before cycle has terminated on timer.	<ol style="list-style-type: none"> Low water cut-off has functioned prematurely. 	<ol style="list-style-type: none"> Replace low water cut-off.
Timer is erratic, or fails to return to zero.	<ol style="list-style-type: none"> Loose or broken electrical leads on timer. 	<ol style="list-style-type: none"> Repair defective wiring.
Unable to obtain set temperature at peak of cycle.	<ol style="list-style-type: none"> Steam trap closing prematurely, preventing removal of air from the chamber. 	<ol style="list-style-type: none"> Replace the thermostatic element in the steam trap.
One or both sides of the cast-in heating elements remain on when the timer is in an OFF position.	<ol style="list-style-type: none"> Contactors of the temperature control switch remains closed. Temperature control not properly calibrated. 	<ol style="list-style-type: none"> Replace switches. Recalibrate.
Heating element cutting out before 15 lbs. of pressure is reached.	<ol style="list-style-type: none"> Pressure cutting off at the temperature control too soon. 	<ol style="list-style-type: none"> See adjusting the range of operation and calibration of the temperature control. Readjust.

ILLUSTRATED PARTS LIST

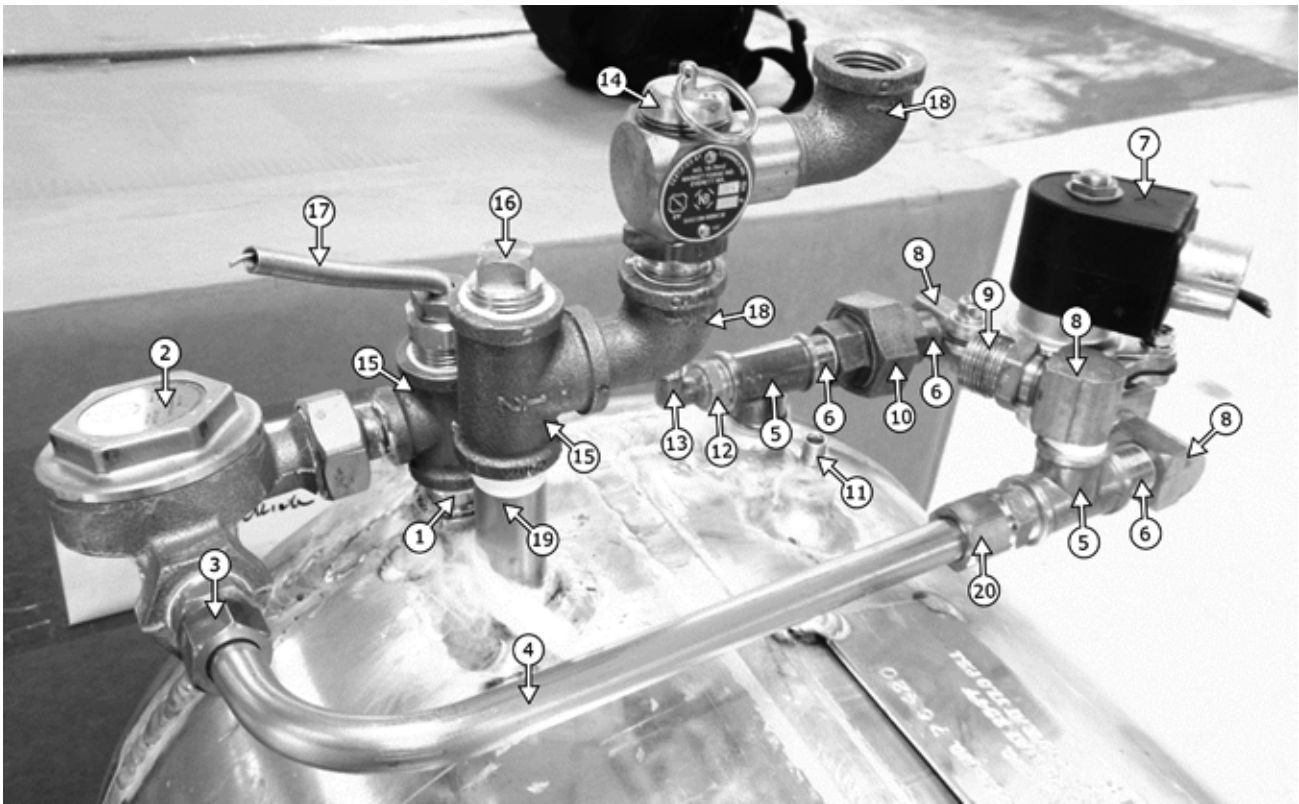

ITEM	QTY.	STM-EL (120V)	STM-ELX (240V)	DESCRIPTION
1	1	95-0438	95-0438	Nipple, 1/2" NPT x 1.5"
2	1	98-1718	98-1718	Steam Trap
3	1	10-1048	10-1048	Compression Fitting, 1/2" OD Tube x 1/2" NPT
4	1	95-2667	95-2667	Tube, Copper, 1/2" OD
5	2	10-1055	10-1055	Tee, Brass, 3/8" x 3/8" x 3/8"
6	3	08-7525	08-7525	Nipple, 3/8" NPT, Close
7	1	10-1058	10-0938	Valve, Solenoid
8	3	10-1054	10-1054	Elbow, Street, 3/8 NPT
9	1	10-1017	10-1017	Adapter, 5/8" OD Tube x 3/8"MNPT
10	1	10-1057	10-1057	Union, 3/8" NPT
11	1	10-7988	10-7988	Bushing, Hex, Reducing 1/4" MNPT
12	1	10-3741	10-3741	Bushing, Hex, Reducing 3/8"NPTx1/4"NPT
13	1	10-3918	10-3918	Fitting, 1/4" Comp. X 1/4" MNPT
14	1	10-7942	10-7942	Valve, Safety, 17PSIG
15	2	10-3352	10-3352	Tee, 1/2" NPT, Brass
16	1	10-3327	10-3327	1/2" NPT Square Plug
17	1			Temp. Probe, Available with Control Module Only
18	2	95-3730	95-3730	Elbow, 1/2" NPT, 90, Street, Modified
19	1	08-4980	08-4980	Nipple, Pipe, Male, 1/2 Npt x 3"
20	1	10-3684	10-3684	Adapter, 1/2" OD Tube to 3/8" NPT

ILLUSTRATED PARTS LIST

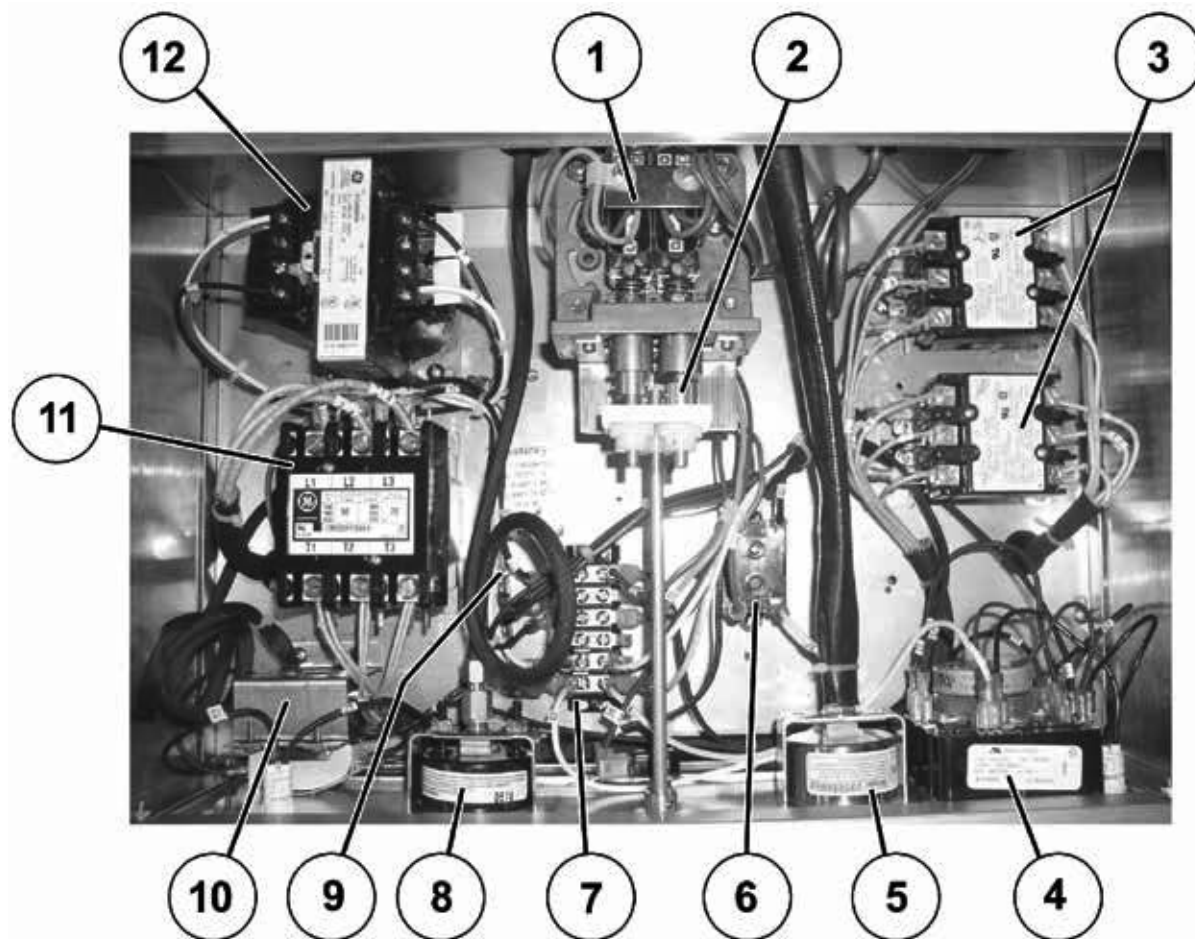

ITEM	STM-EL		STM-ELX (EXPORT)		DESCRIPTION
	QTY.	PART NO.	QTY.	PART NO.	
1	1	95-3434	1	95-3434	Barksdale Pressure Switch
2	1	95-2907	1	95-2907	Pressure Switch Gear Assy.
3	2	10-5944	-	N/A	Contactor, 120V Coil
3	-	N/A	2	10-5943	Contactor, 240V Coil
4	1	10-6290	-	N/A	Timer, 120V
4	-	N/A	1	10-6873	Timer, 240V
5	1	10-9268	1	10-9268	Temperature Gauge
6	1	10-6515	-	N/A	Relay, 120V
6	-	N/A	1	10-6874	Relay, 208/240V
7	1	10-6005	1	10-6005	Terminal Block
8	1	10-9267	1	10-9267	Pressure Gauge
9	1	08-6469	1	08-6469	Fuse Holder
10	1	10-5990	1	10-5990	Low Water Cut-off
11	1	09-6483	-	N/A	Contactor, 75 Amps, 120V
11	-	N/A	1	09-6484	Contactor, 75 Amps, 240V
12	1	10-7355	1	10-7355	Transformer, 100 KVA, 60Hz

ILLUSTRATED PARTS LIST

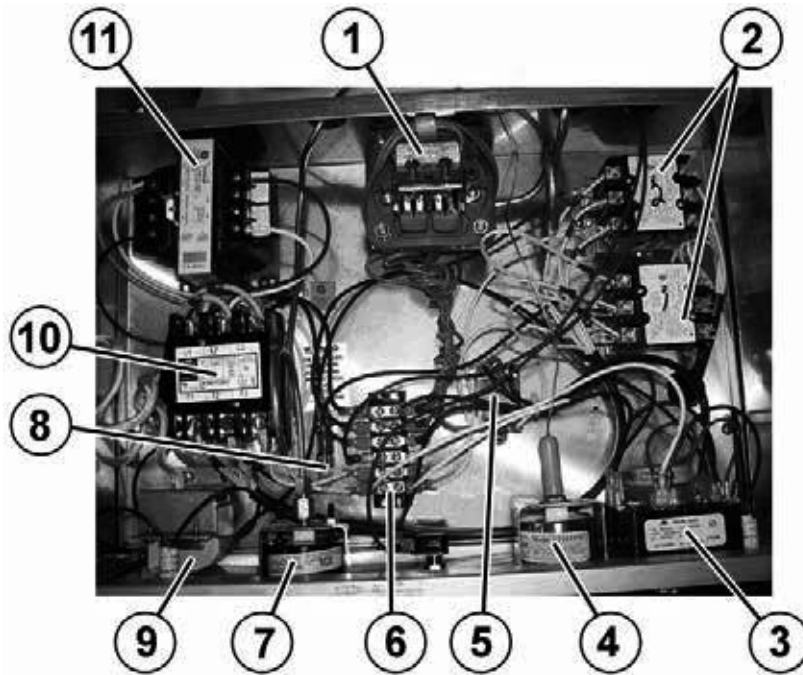

ITEM	STM-E		STM-EX (EXPORT)		DESCRIPTION
	QTY.	PART NO.	QTY.	PART NO.	
1	1	95-3442	1	95-3442	Barksdale Pressure Switch
2	2	10-5944	-	N/A	Contactors 120V Coil
3	-	N/A	2	10-5943	Contactors 240V Coil
3	1	10-6290	-	N/A	Timer 120V
4	-	N/A	1	10-6873	Timer 240V
4	1	10-9268	1	10-9268	Temperature Gauge
5	1	10-6515	-	N/A	Relay, 120V
6	-	N/A	1	10-6874	Relay, 208/240V
6	1	10-6005	1	10-6005	Terminal Block
7	1	10-9267	1	10-9267	Pressure Gauge
8	1	08-6469	1	08-6469	Fuse Holder
9	1	10-5990	1	10-5990	Low Water Cutt-Off
10	1	09-6483	-	N/A	Contactors, 75 Amps, 120V
10	-	N/A	1	09-6484	Contactors, 75 Amps, 240V
11	1	10-7355	1	10-7355	Transformer, 100KVA, 60HZ

ILLUSTRATED PARTS LIST

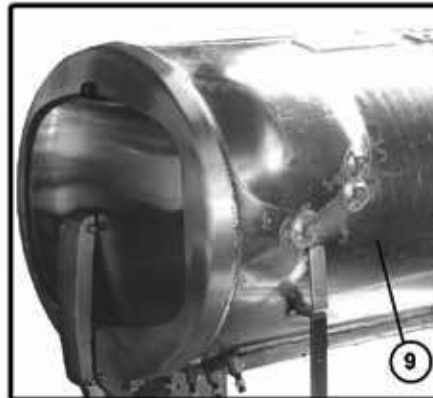
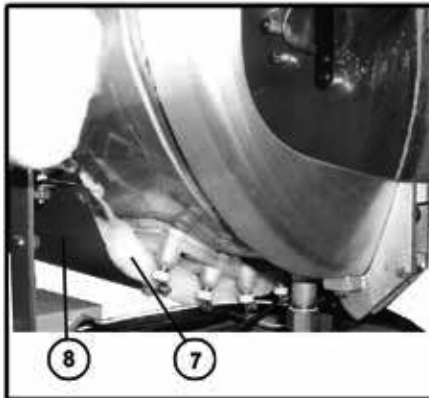
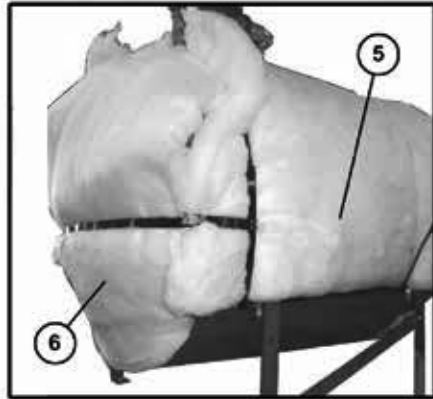
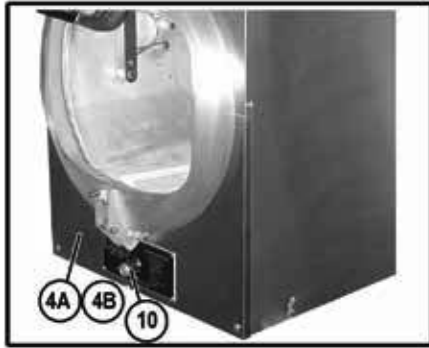
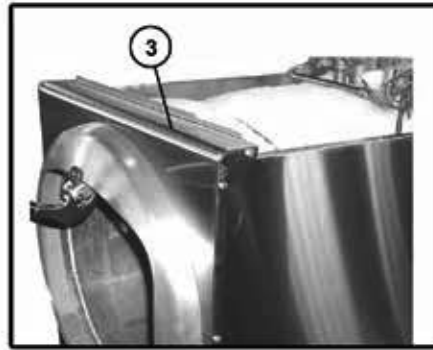
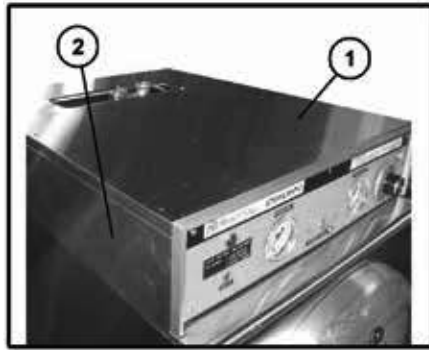

ITEM	ALL MODELS		DESCRIPTION
	QTY.	PART NO.	
1	1	95-2558	Flue Cover Assy.
2	1	95-2652	Flue Outer Case Wrap
3	1	95-2650	Upper Case, Front
4A	1	98-4372	Lower Case, Front w/cutout
4B	1	98-4373	Lower Case, Front Access Panel
5	1	10-6363	Insulation, Body
6	1	10-6365	Insulation, Back
7	1	10-6364	Insulation, Bottom
8	1	95-0465	Bottom Cover for Elements
9	1	98-4217	Cylinder, 208V - 240V (Shown with Door Assy.)
10		10-5938	Plate, Drain Panel Clean Instr

ILLUSTRATED PARTS LIST

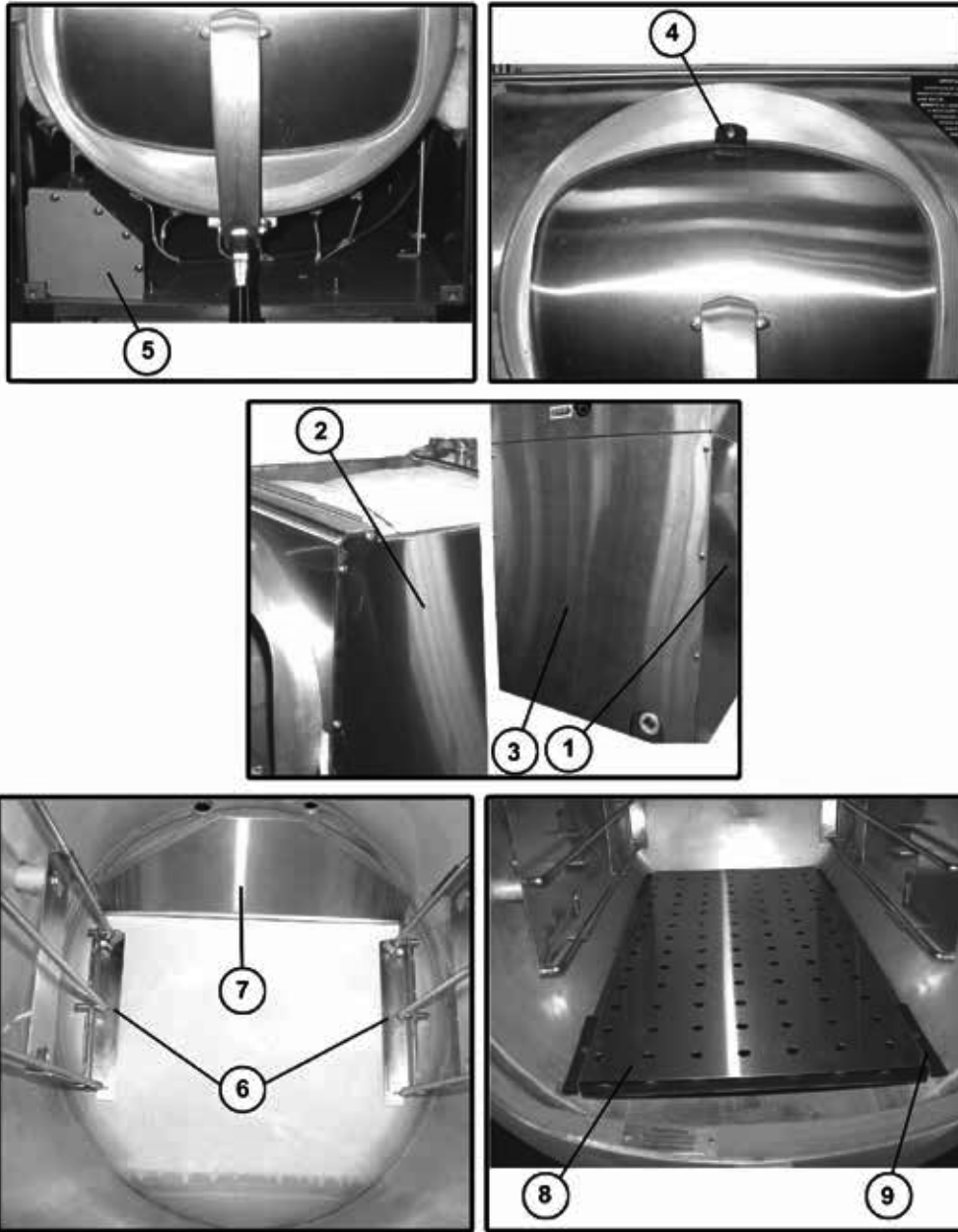

ITEM	ALL MODELS		DESCRIPTION
	QTY.	PART NO.	
1	1	95-3196	Outside Case, Left Side
2	1	95-3195	Outside Case, Right Side
3	1	95-3194	Outside Case, Back
4	1	10-0226	Handle Bumper
5	1	95-3484	Terminal Box Cover
6	2	95-2545	Pan Rack, 1 Left & 1 Right
7	1	95-2637	Condensate Baffle, Upper
8	1	95-3207	Perforated Water (<i>Splash</i>) Baffle
9	4	95-3284	Wear Strip

ILLUSTRATED PARTS LIST

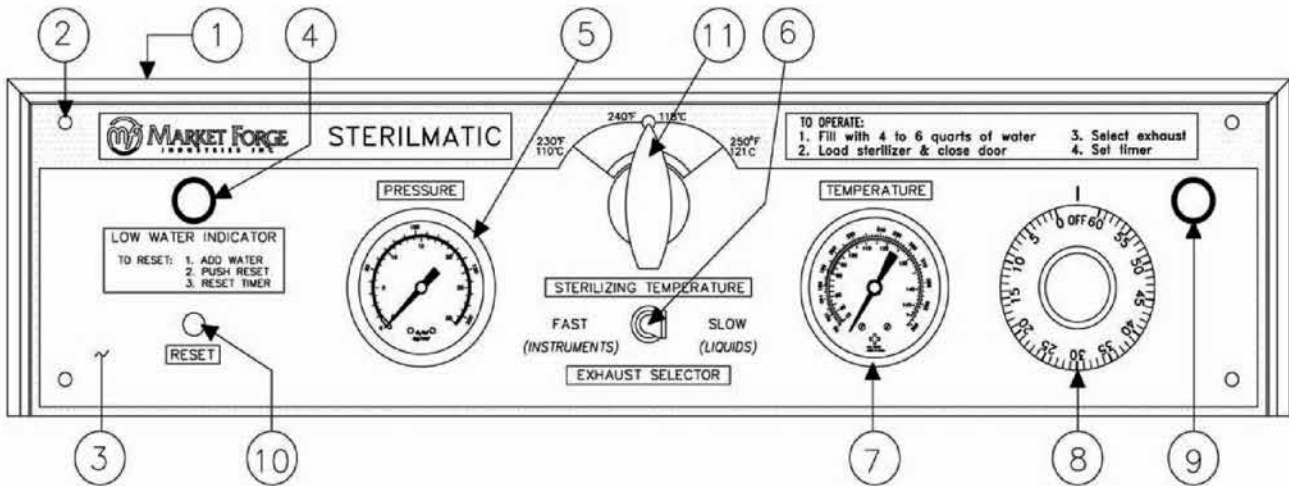
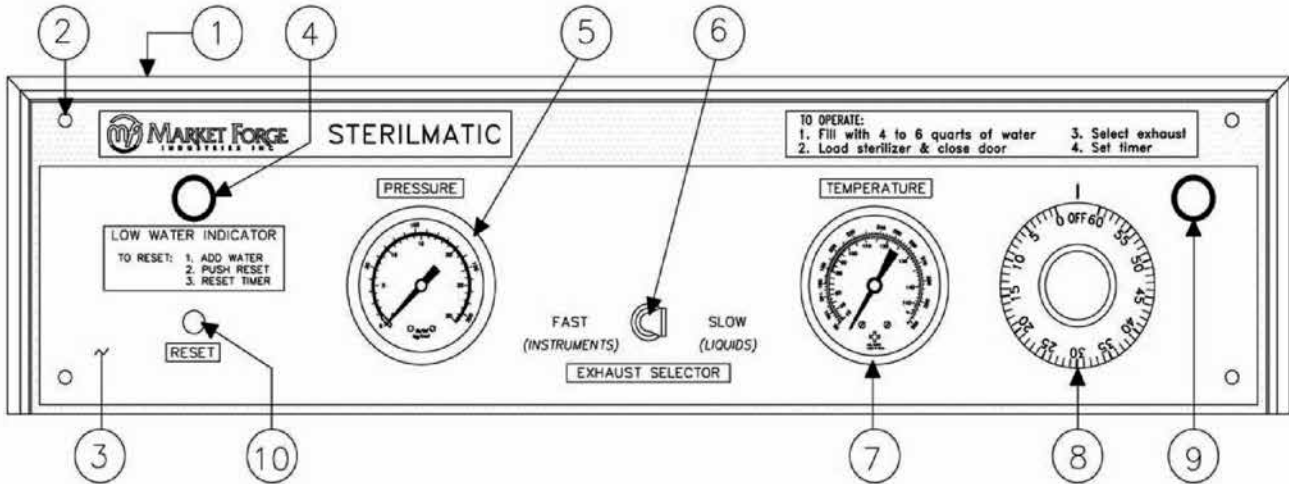

ITEM	STM-E PART NO.	STM-EX PART NO.	STM-EL PART NO.	STM-ELX PART NO.	DESCRIPTION
1	10-0489	-	10-0489	-	Bezel
2	10-1722	-	10-1722	-	Round Head Machine Screw, 6-32
3	10-9280	-	10-9279	-	Control Panel
4	10-5052	10-6669	10-5052	10-6669	Pilot Light, Red
5	10-9267	10-9271	10-9267	10-9271	Pressure Gauge
6	10-5999	-	10-5999	-	Switch
7	10-9268	-	10-9268	-	Temperature Gauge
8	10-0189	-	10-0189	-	Timer Knob
9	10-5940	10-6876	10-5940	10-6876	Pilot Light, White
10	10-5990	-	10-5990	-	Low Water Cut-Off
11	-	-	10-0051	-	Knob

ILLUSTRATED PARTS LIST

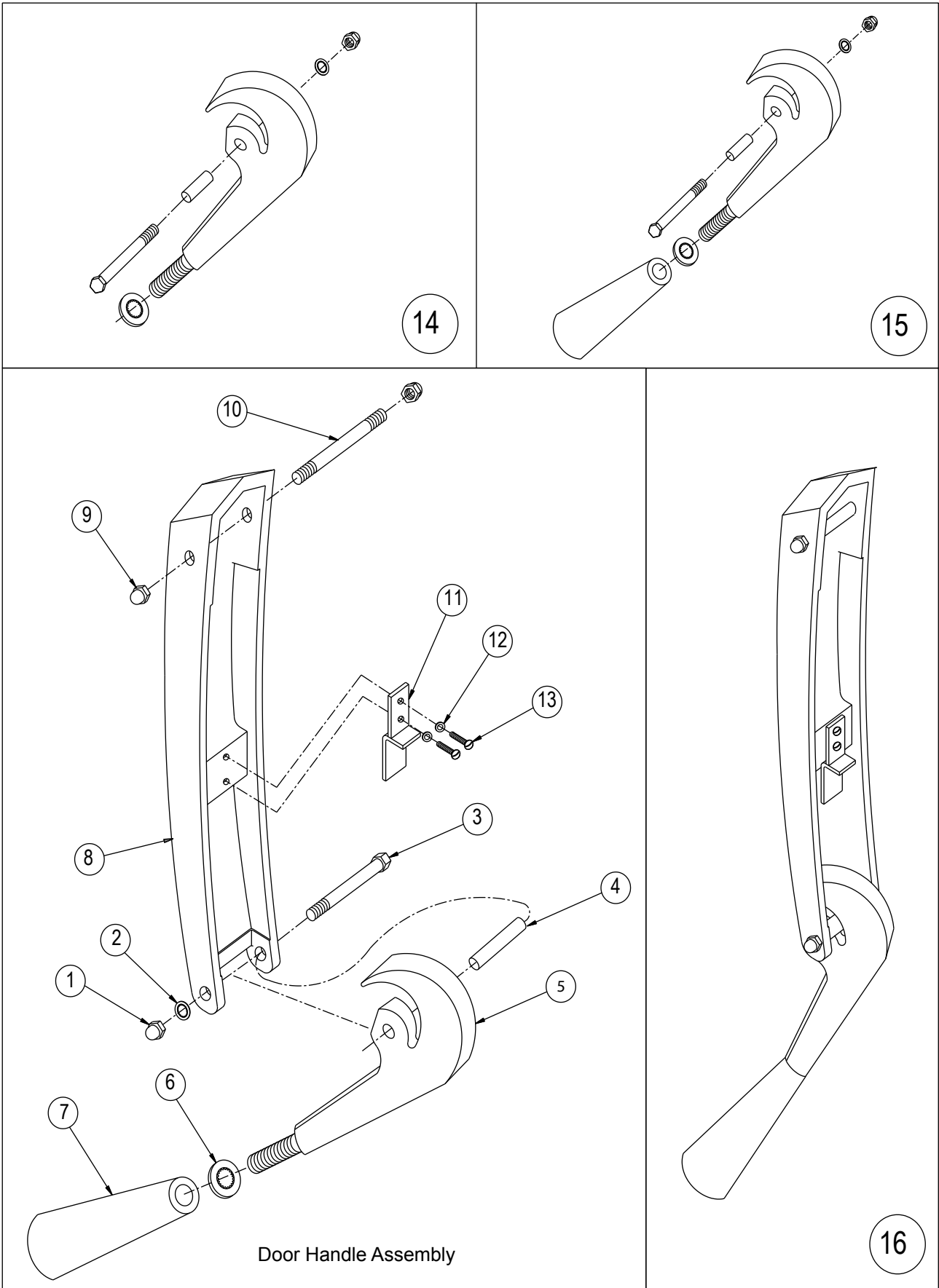

Door Handle Assembly

ILLUSTRATED PARTS LIST

DOOR HANDLE ASSEMBLY

ITEM	PART NO.	DESCRIPTION
1	10-2318	10-32 Acorn Nut
2	10-2514	#10 Shakeproof Lockwasher
3	10-1999	10-32 Machine Screw 1 3/8" Lg.
4	95-0120	Bearing Spacer
5	95-0136	Door Lock Casting
6	10-2517	3/8" Shakeproof Lockwasher
7	10-0050	Door Lock Knob
8	95-0134	Door Handle Casting
9	10-2359	1/4"-20 Acorn Nut
10	95-0658	Door Handle Bearing Stud
11	14-0721	Door Handle Bearing Plate
12	10-2513	1/4" Shakeproof Lockwasher
13	10-1731	1/4"-20 Machine Screw 5/8" Lg.
14	95-0190	Door Lock Casting Assy. (Items 1 through 6)
15	95-0145	Door Lock Knob Assy. (Items 1 through 7)
16	95-0144	Complete Door Handle Assy. (Items 1 through 13)
17	95-0198	Handle Bushing (Not Shown)

MISCELLANEOUS PARTS NOT SHOWN

STM-E(L)		STM-E(L)X		DESCRIPTION
QTY.	PART NO.	QTY.	PART NO.	
1	95-2606			Temperature Recorder, 120 V (Optional)
		1	10-5343	Temperature Recorder, 240 V (Optional)
1	20-0316	-	-	Replacement Probe (For Recorder)
1	95-2653	-	-	Upper Mounting Plate
1	10-5788	-	-	120v, 50/60 Hz Cycle Coil
1	95-3552	-	-	Wire Harness, Flue Assy.
1	95-3553	-	-	Wire Harness, Contactors