



MAXX

COLD

X-series

Pizza Prep Tables
Megatop Sandwich/Salad Units
Undercounter Refrigerators and Freezers
Worktop Refrigerators and Freezers

INSTRUCTION MANUAL





MAXX COLD

X-series

SERIAL NUMBER INFORMATION

The serial number of all self-contained refrigerators and freezers is located inside the unit on the left hand side near the top on the wall. Always have the serial number of your unit available when calling for parts or service. This manual covers standard units only. If you have a custom unit, consult the customer service department at the number listed on the last page.

RECEIVING AND INSPECTING THE EQUIPMENT

Even though most equipment is shipped in protective packaging, care should be taken during unloading so the equipment is not damaged while being moved into the building.

1. Visually inspect the exterior of the package and skid or container. Any damage should be noted and reported to the delivering carrier immediately.
2. If damaged, open and inspect the contents with the carrier.
3. In the event that the exterior is not damaged, yet upon opening there is concealed damage to the equipment, notify the carrier. Notification should be made verbally as well as in written form.
4. Request an inspection by the shipping company of the damaged equipment. This should be done within 10 days from receipt of the equipment.
5. Be certain to check the compressor compartment housing and visually inspect the refrigeration package. Be sure lines are secure and base is still intact.
6. Freight carriers can supply the necessary damage forms upon request.
7. Retain all crating material until an inspection has been made or waived.

SAVE THESE INSTRUCTIONS



MAXX COLD

X-series

SPECIFICATIONS

PIZZA PREP TABLES										
MODEL #	V/Hz/Ph	AMPS	STORAGE CAPACITY	PAN 1/3	SHELF CAPACITY	HP	BTU	CHARGE	SHIP WEIGHT	NEMA PLUG
			Cu-ft	Size	Sq-ft			OZ	LBS	
MXCPP50	115/60/1	7	12	6	16	1/2	5600	9.9	348	5-15P
MXCPP70	115/60/1	7.5	22	9	34	1/2	6200	10.6	432	5-15P
MXCPP92	115/60/1	9	32	12	54	3/4	6800	13.8	582	5-15P

SANDWICH / SALAD UNITS										
MODEL #	V/Hz/Ph	AMPS	STORAGE CAPACITY	PAN 1/6	SHELF CAPACITY	HP	BTU	CHARGE	SHIP WEIGHT	NEMA PLUG
			Cu-ft	Size	Sq-ft			OZ	LBS	
MXCR29S	115/60/1	5	7	8	14	3/8	3200	9.5	276	5-15P
MXCR48S	115/60/1	7	12	12	26	1/2	5400	9.5	313	5-15P
MXCR60S	115/60/1	7.5	15.5	16	30	1/2	5800	10.6	362	5-15P

MEGATOP SANDWICH / SALAD UNITS										
MODEL #	V/Hz/Ph	AMPS	STORAGE CAPACITY	PAN 1/6	SHELF CAPACITY	HP	BTU	CHARGE	SHIP WEIGHT	NEMA PLUG
			Cu-ft	Size	Sq-ft			OZ	LBS	
MXCR29M	115/60/1	5	7	12	14	3/8	3200	9.5	276	5-15P
MXCR48M	115/60/1	7	12	18	26	1/2	5400	9.5	313	5-15P
MXCR60M	115/60/1	7.5	15.5	24	30	1/2	5800	10.6	362	5-15P

UNDERCOUNTER & WORKTOP REFRIGERATORS										
MODEL #	V/Hz/Ph	AMPS	STORAGE CAPACITY	SHELF CAPACITY	HP	BTU	CHARGE	SHIP WEIGHT	NEMA PLUG	
			Cu-ft	Sq-ft			OZ	LBS		
MXCR27U	115/60/1	5	6.5	14	3/8	2800	9.5	243	5-15P	
MXCR48U	115/60/1	5	12	26	3/8	3000	9.5	300	5-15P	
MXCR60U	115/60/1	5	15.5	30	3/8	3200	10.6	348	5-15P	

UNDERCOUNTER & WORKTOP FREEZERS										
MODEL #	V/Hz/Ph	AMPS	STORAGE CAPACITY	SHELF CAPACITY	HP	BTU	CHARGE	SHIP WEIGHT	NEMA PLUG	
			Cu-ft	Sq-ft			OZ	LBS		
MXF27U	115/60/1	7	6.5	14	1/2	3500	12.3	291	5-15P	
MXF48U	115/60/1	9	12	26	1/2	3800	13.4	340	5-15P	
MXF60U	115/60/1	10	15.5	30	5/8	4200	14.1	388	5-15P	



MAXX COLD

X-series

INSTALLATION

Location:

Units represented in this manual are intended for indoor use only. Be sure the location chosen has a floor strong enough to support the total weight of the cabinet and contents. A fully loaded unit can weigh as much as 1500 pounds. Reinforce the floor as necessary to provide for maximum loading. For the most efficient refrigeration, be sure to provide good air circulation inside and out.

Inside cabinet:

Do not pack the units so full that air cannot circulate. The refrigerated air is discharged at the top rear of the unit. It is important to allow for proper air flow from the top rear to the bottom of the unit. Obstructions to this air flow can cause evaporator coil freeze ups and loss of temperature or overflow of water from the evaporator drain pan. The shelves have a rear turn up on them to prevent this, however bags and other items can still obstruct air flow in the far rear of the cabinet. Air is brought into the evaporator coil with fans. Prevent obstruction by locating large boxes and tall stacks of product away from the outlet or inlet of air flow.

Outside cabinet:

Be sure that the unit has access to ample air. Avoid hot corners and locations near stoves and ovens. It is recommended that the unit be installed no closer than 6" from any wall.

Leveling:

A level cabinet looks better and will perform better because the doors will line up with the frames properly, the cabinet will not be subject to undue strain and the contents of the cabinet will not move around on the shelves. Use a level to make sure the unit is level from front to back and side to side. Units supplied with legs will have adjustable bullet feet to make the necessary adjustments. If the unit is supplied with casters, no adjustments are available. Ensure the floor where the unit is to be located is level.

Stabilizing:

All models are supplied with casters for your convenience, ease of cleaning underneath and for mobility. It is very important, however, that the cabinet be installed in a stable condition with the front wheels locked while in use. Should it become necessary to lay the unit on its side or back for any reason, allow at least 24 hours before start-up so as to allow compressor oil to flow back to the sump. Failure to meet this requirement can cause compressor failure and unit damage.



NOTE

Unit repairs will not be subject to standard unit warranties due to improper installation procedures.



MAXX

COLD X-series

INSTALLATION

Electrical connection:

Refer to the amperage data on page 3, the serial tag, your local code or the National Electrical Code to be sure the unit is connected to the proper power source. A protected circuit of the correct voltage and amperage must be run for connection of the line cord, or permanent connection to the unit.



The on/off switch must be turned to OFF and the unit disconnected from the power source whenever performing service, maintenance functions or cleaning the refrigerated area.

OPERATION



Do not throw items into the storage area. Failure to heed these recommendations could result in damage to the interior of the cabinet.

Refrigerated cabinets:

Temperature range for the internal cabinets is 33° to 40°F for all food prep units, undercounter and worktop refrigerators and -7° to -3°F for undercounter and worktop freezers. The rail's temperature range for all prep units is 33° to 41°F.

Food Prep units should operate with pans in place. Operation without pans and/or pan covers in place will lower efficiency and may damage the unit due to continuous running.

Continuous opening and closing of the door will prevent the unit's ability to maintain optimum refrigeration temperature.

The top section is not intended for overnight storage. Product should be removed from pans. Pans can remain in cabinet while empty.

Defrosting:

Every 6 hours, the unit will shut off to let the evaporator coil clear up the ice and the controller will display the defrost symbol. When the coil temperature reaches terminal temperature or after 20 minutes, the unit will start to work again.

On/Off Switch:

An on/off switch is located on the front of the bottom shroud and on the condenser compartment door for the Pizza prep tables. When the unit is on, the switch will glow green.



MAXX COLD X-series

SOLID-STATE THERMOSTAT DESCRIPTION

1. FRONT PANEL COMMANDS



SET: To display target set point; in programming mode it is used to select a parameter or confirm an operation



(DEF) To start a manual defrost



(UP): To see the last temperature alarm; in programming mode it browses the parameter codes or increases the displayed value



(DOWN) To see the last temperature alarm; in programming mode it browses the parameter codes or decreases the displayed value.

KEY COMBINATIONS:

▲ + ▼ To lock & unlock the keyboard.

SET + ▼ To enter in programming mode.

SET + ▲ To return to the room temperature display.

1.1 USE OF LEDS

Each LED function is described in the following table.

LED	MODE	FUNCTION
	ON	Compressor enabled
	Flashing	- Programming Phase (flashing with) - Anti-short cycle delay enabled
	ON	Defrost enabled
	Flashing	- Programming Phase (flashing with) - Drip time in progress
	ON	Fans enabled
	Flashing	Fans delay after defrost in progress.
	ON	An temperature alarm happened

2.4 HOW TO LOCK THE KEYBOARD



1. Keep pressed for more than 3s the UP and DOWN keys.
2. The "POF" message will be displayed and the keyboard will be locked. At this point it will be possible only to see the set point or the MAX o Min temperature stored
3. If a key is pressed more than 3s the "POF" message will be displayed.

2.5 TO UNLOCK THE KEYBOARD

Keep pressed together for more than 3s the ▲ and ▼ keys, till the "Pon" message will be displayed.

2. MAIN FUNCTIONS

2.1 HOW TO SEE THE SETPOINT



1. Push and immediately release the **SET** key; the display will show the Set point value;
2. Push and immediately release the **SET** key or wait for 5 seconds to display the probe value again.

2.2 HOW TO CHANGE THE SETPOINT

1. Push the **SET** key for more than 2 seconds to change the Set point value;
2. The value of the set point will be displayed and the LED starts blinking;
3. To change the Set value push the ▲ or ▼ arrows within 10s.
4. To memorise the new set point value push the **SET** key again or wait 10s.

2.3 HOW TO START A MANUAL DEFOST



Push the **DEF** key for more than 2 seconds and a manual defrost will start.

3. ALARM SIGNALS

Message	Cause	Outputs
P1*	Room probe failure	Compressor output according to par. "Con" and "COF"
P2*	Evaporator probe failure	Defrost end is timed
P3*	Condenser probe failure	Outputs unchanged.
HA*	Maximum temperature alarm	Outputs unchanged.
LA*	Minimum temperature alarm	Outputs unchanged.
DA*	Door open	Compressor and fans restarts
EA*	External alarm	Output unchanged.
CA*	Serious external alarm (1F-eAL)	All outputs OFF.
CSD*	Condenser alarm	All outputs OFF.

3.1 HOW TO SEE THE ALARM AND RESET THE REGISTERED ALARM

1. Push the UP or Down key, the alarm signals are displayed.
2. When the signal is displayed, hold the SET key until the "rst" message is displayed, and push the SET again, the "rst" message starts blinking and the normal temperature will be displayed.



MAXX

COLD X-series

MAINTENANCE



The power switch must be turned to OFF and the unit disconnected from the power source whenever performing service, maintenance functions or cleaning the refrigerated area.

Refrigerators and Freezers

The interior and exterior can be cleaned using soap and warm water. If this isn't sufficient, try ammonia and water or a nonabrasive liquid cleaner. When cleaning the exterior, always rub with the "grain" of the stainless steel to avoid marring the finish. Do not use an abrasive cleaner because it will scratch the stainless steel and plastic and can damage the breaker strips and gaskets.

Cleaning the Condenser Coil

The condenser coil requires regular cleaning, at least every 90 days. In some instances you may find that there is a large amount of debris and dust or grease accumulated prior to the 90 day time frame. In these cases the condenser coil should be cleaned every 30 days. If the build up on the coil consists of only light dust and debris the condenser coil can be cleaned with a simple brush. Heavier dust build up may require a vacuum or even compressed air to blow through the condenser coil. If heavy grease is present there are de-greasing agents available for refrigeration use and specifically for the condenser coils. The condenser coil may require a spray with the de-greasing agent and then blown through with compressed air. Failure to maintain a clean condenser coil can initially cause high temperatures and excessive run times. Continuous operation with dirty or clogged condenser coils can result in compressor failures. Neglecting the condenser coil cleaning procedures will void any warranties associated with the compressor or cost to replace the compressor.



Never use a high pressure water wash for this cleaning procedure as water can damage the electrical components located near or at the condenser coil.

In order to maintain proper refrigeration performance, the condenser fins must be cleaned of dust, dirt and grease regularly. It is recommended that this be done at least every three months. If conditions are such that the condenser is totally blocked in three months, the frequency of cleaning should be increased. Clean the condenser with a vacuum cleaner or stiff brush. If extremely dirty, a commercially available condenser cleaner may be required.



MAXX

COLD X-series

MAINTANANCE

Stainless Steel Care and Cleaning

To prevent discoloration or rust on stainless steel, several important steps need to be taken. Stainless steel contains 70-80% iron which will rust. It also contains 12-30% chromium which forms an invisible passive film over the steel's surface which acts as a shield against corrosion. As long as the protective layer is intact, the metal is still stainless. If the film is broken or contaminated, outside elements can begin to break down the steel and begin to form rust or discoloration. Proper cleaning of stainless steel requires soft cloths or plastic scouring pads,



NEVER USE STEEL PADS, WIRE BRUSHES OR SCRUBBERS.

Cleaning solutions need to be alkaline based or non-chloride cleaners. Any cleaner containing chlorides will damage the protective film of the stainless steel. Chlorides are also commonly found in hard water, salts, and household and industrial cleaners. If cleaners containing chlorides are used be sure to rinse repeatedly and dry thoroughly upon completion.

Routine cleaning of stainless steel can be done with soap and water. Extreme stains or grease should be cleaned with a non-abrasive cleaner and plastic scrub pad. It is always good to rub with the grain of the steel. There are also stainless steel cleaners available which can restore and preserve the finish of the steel's protective layer.

Early signs of stainless steel breakdown can consist of small pits and cracks. If this has begun, clean thoroughly and start to apply stainless steel cleaners in attempt to restore the passivity of the steel.



Never use an acid based cleaning solution. Many food products have an acidic content which can deteriorate the finish. Be sure to clean the stainless steel surfaces of ALL food products. Common items include, tomatoes, peppers and other vegetables.

Gasket Maintenance

Gaskets require regular cleaning to prevent mold and mildew build up and also to keep the elasticity of the gasket. Gasket cleaning can be done with the use of warm soapy water. Avoid full strength cleaning products on gaskets as this can cause them to become brittle and prevent proper seals. Also, never use sharp tools or knives to scrape or clean the gasket which could possibly tear the gasket. Gaskets can easily be replaced and do not require the use of tools or authorized service persons, The gaskets are "Dart" style and can be pulled out of the groove in the door and new gaskets can be "pressed" back into place.



MAXX

COLD

X-series

MAINTENANCE

Doors/Hinges

Over time and with heavy use doors the hinges may become loose. If the door is beginning to sag, it may become necessary to tighten the screws that mount the hinge brackets to the frame of the unit. If the doors are loose or sagging this can cause the hinge to pull out of the frame which may damage both the doors and the door hinges. In some cases this can require qualified service agents or maintenance personnel.

Drain Maintenance

Each unit has a drain located inside the unit which removes the condensation from the evaporator coil and evaporates it at an external condensate evaporator pan. Each drain can become loose or disconnected from moving or bumping the drain. If you notice excessive water accumulation on the inside of the unit be sure the drain tube is connected from the evaporator housing to the condensate evaporator drain pan. If water is collected underneath the unit you may want to check the condensate evaporator drain tube to be sure it is still located inside the drain pan. The leveling of the unit is important as the units are designed to drain properly when on a level surface, if your floor is not level this can also cause drain problems. Be sure all drain lines are free of obstructions. Typically food product may block drain lines, causing water to back up and overflow the drain pans.

Door Replacement and Adjustment

1. Open the door to about 100-110° until the door remains open.
2. Loosen and remove the bottom screw of self-closing cartridge and the three hinge screws, then slide the door down and out.
3. Prepare the new door. Use a wrench to rotate the square head of the cartridge shaft approximately 120° in the closing direction of the door. The hinge is now pre-loaded and ready to be secured to the bottom hinge
4. Hold the door at about 100° from the closed position, insert the bottom hinge over the square shaft of the cartridge so that the hinge is facing the cabinet. Insert the mounting screw and fasten securely.
5. Still holding the the entire door/hinge assembly at about 100°, slide it up to the top hinge pin, ensuring proper alignment then fasten the bottom hinge securely.
6. Allow the door to freely swing, making sure it swings closed by itself without restriction.



MAXX

COLD X-series

MAINTENANCE

Open the bottom shroud

Loosen and remove the screw from the two holes in front of the bottom shroud, then the bottom shroud can be move out.

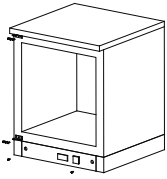

WIRING DIAGRAM

Model: MXCPP50/70/92 - MCR29S/48S/60S - MCR29M/48M/60M - MXCR27U/48U/60U

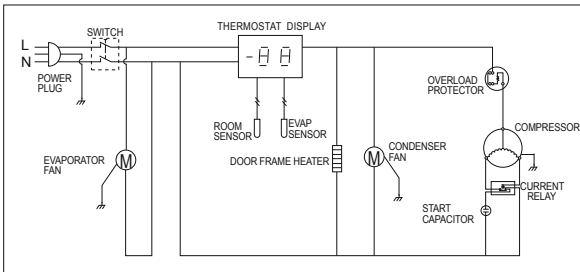

Model: MXCF27U/48U/60U

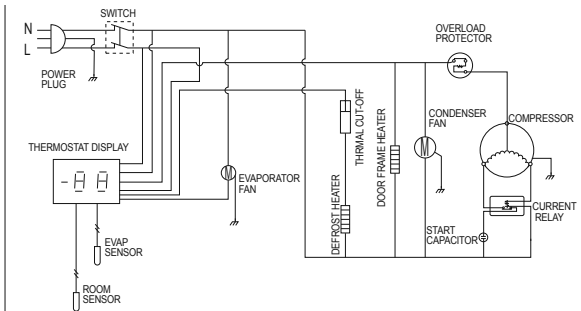



MAXX

COLD X-series

WIRING DIAGRAM

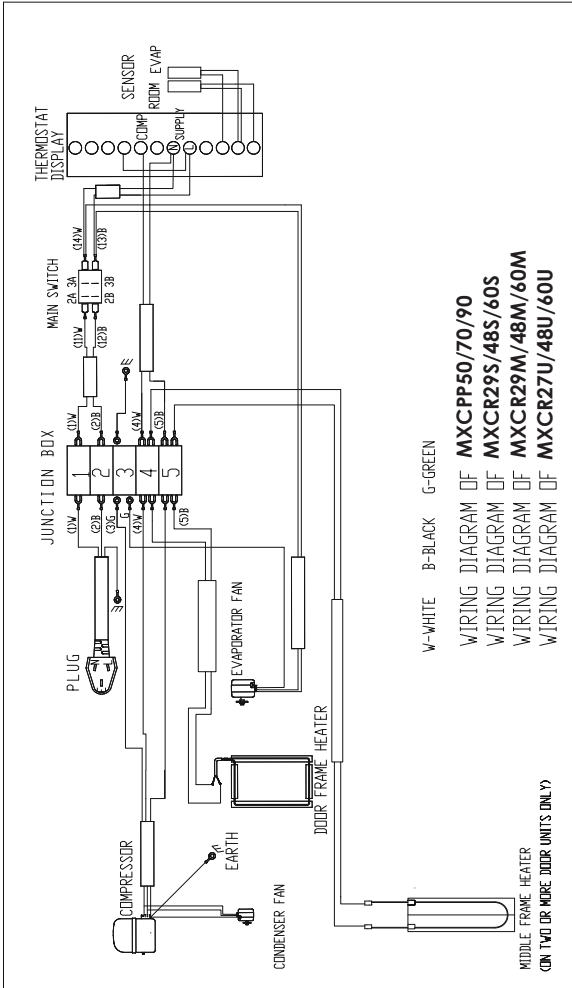



MAXX

COLD X-series

WIRING DIAGRAM

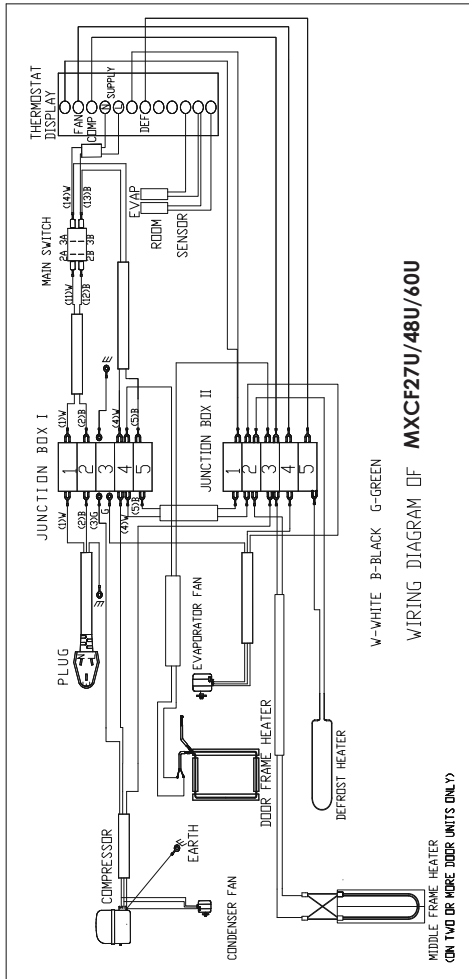



www.maxxcoldfoodservice.com

3355 Enterprise Ave, Suite #160,
Fort Lauderdale, FL 33331
Phone:(954) 202-7419 · Fax:(954) 202-7337