

# MODEL FV 250.2



High Temperature Sanitizing Pot and Pan Washer  
(USA Version)

## OWNER'S INSTALLATION, OPERATION AND MAINTENANCE MANUAL



## TABLE OF CONTENTS

1. INTRODUCTION .....	3	3.12 Drain Hose Positioning .....	11
1.1 Overview of Equipment .....	3	3.13 Final Assembly .....	11
1.2 General Safety Information .....	3	3.14 Priming the Liquid Detergent and Rinse Additive Lines .....	12
2. TRANSPORT AND SHIPPING .....	3	3.15 Checking for Correct Chemical Concentration .....	12
3. INSTALLATION .....	4	4. OPERATION .....	13
3.1 Overview of Installation .....	4	4.1 Location and Description of Controls .....	13
3.2 Requirements Before Installation .....	4	4.2 Startup .....	14
3.3 Uncrating, Positioning and Leveling .....	5	4.3 Loading .....	14
3.4 Accessing the Utility Connections .....	5	4.4 Operation .....	16
3.5 Main Electrical Supply Connection .....	6	4.5 Between Cycles .....	16
3.6 Dispensing System Overview .....	7	4.6 Shutdown .....	16
3.7 Installing an External Detergent System ...	8	5. CLEANING .....	17
3.8 Installing an External Liquid Rinse Aid System .....	9	5.1 Daily Cleaning (or as required) .....	17
3.9 Wiring External Chemical Dispensing Systems .....	9	5.2 Weekly Cleaning (or as required) .....	18
3.10 Connecting Chemical Containers or Dispensers .....	10	5.3 Exterior Cleaning (as required) .....	19
3.11 Fresh Water Supply Connection .....	11	5.4 Deliming (as required) .....	19
		6. TROUBLESHOOTING .....	20

AN ELECTRICAL WIRING DIAGRAM IS LOCATED INSIDE THE  
LOWER-FRONT COMPARTMENT OF THIS MACHINE.

THE MEIKO MODEL FV 250.2 HAS BEEN DESIGNED EXCLUSIVELY  
FOR THE WASHING OF POTS, PANS, TRAYS, KITCHEN UTENSILS, CUTLERY,  
DISHES AND GLASSWARE IN A COMMERCIAL OR INSTITUTIONAL SETTING  
AND MUST NOT BE USED FOR ANY OTHER PURPOSE.

MEIKO ACCEPTS NO RESPONSIBILITY FOR DAMAGE TO THE APPLIANCE, SURROUNDING  
EQUIPMENT OR ENVIRONMENT THAT IS CAUSED BY INAPPROPRIATE INSTALLATION OR  
OPERATION, OR FROM ANY SERVICE THAT IS UNDERTAKEN BY NON-AUTHORIZED  
PERSONNEL, OR FROM THE USE OF ANY PARTS EXCEPT THOSE THAT ARE APPROVED BY THE  
MANUFACTURER. ANY SUCH INSTALLATION, USE OR SERVICE WILL IMMEDIATELY VOID THE  
MANUFACTURER'S WARRANTY.

ANY MODIFICATIONS TO THE APPLIANCE THAT ARE PERFORMED WITHOUT THE WRITTEN  
PERMISSION OF MEIKO WILL IMMEDIATELY VOID THE MANUFACTURER'S WARRANTY.

Meiko reserves the right to change any specifications without notice at any time.



# 1 INTRODUCTION

## 1.1 Overview of Equipment

The Meiko Model FV 250.2 is a commercial pot and pan washer/dishwasher. It is designed for cleaning pots, pans, trays, kitchen utensils, cutlery, dishes and glassware with a minimum of employee intervention or supervision.

A control keypad allows easy selection of three different washing cycles to accommodate different types of ware and levels of soiling. A digital display permits easy monitoring of operation.

Other features of the unit that affect operation include:

**Auto Safe** - An internal booster heater is controlled by the electronic control system to ensure proper wash and rinse temperatures, regardless of the incoming water supply.

**Soft Start** - The wash water is pumped at a reduced pressure for the first few seconds of the wash cycle. This protects the ware from being moved or damaged by a sudden burst of pressure.

**Pumped Rinse** - An internal rinse pump ensures that the final rinse pressure is constant.

**Pumped Drain** - Accommodates wall or floor drains.

**Aqua Stop** - The unit will automatically shut down if a water leak is detected.

For efficient and SAFE operation, be sure to follow the installation and operating instructions provided in this manual. In particular, all safety symbols and notices on the equipment and in the supplied documentation must be followed.

### **IMPORTANT**

The Model FV 250.2 has been designed exclusively for the washing of pots, pans, trays, kitchen utensils, cutlery, dishes and glassware in a commercial or institutional setting and must not be used for any other purpose.

## 1.2 General Safety Information

The following symbols and headings are used throughout this manual to indicate possible hazards to persons or to the equipment. The symbols and headings are shown in order of importance. The descriptive text following these headings is *italicized* for easy recognition.



**WARNING!** *Possible hazard to persons, such as from electrical shock, crushing, or hot surfaces.*

### **CAUTION**

*Possible hazard to the dishwasher or to other equipment.*

### **IMPORTANT**

*Vital information or tips for the installer or operator.*

### **NOTE**

*Information or tips for the installer or operator.*

# 2 TRANSPORT AND SHIPPING

### **IMPORTANT**

- *Observe any notices on the crating material that pertain to shipping.*
- *Use care when transporting the equipment.*
- *As you unpack the equipment, check that all components shown on the shipping invoice are present and intact. Be sure to check for shipping damage. If shipping damage is present, call Meiko Customer Service at 1-800-868-3840, providing full details on the customer, serial number and extent of damage present. Meiko will file a freight claim based on this information.*



**WARNING!** *In NO EVENT should a damaged appliance be installed or operated!*



## 3 INSTALLATION

### 3.1 Overview of Installation

The owner should contract with qualified personnel to move the appliance to the installation location, unpack it, and prepare it for final utility connections. In most cases, local codes prevent the final utility connections from being made by any party other than a licensed electrician and/or plumber.

#### **IMPORTANT**

*It is the responsibility of the owner to ensure that all aspects of the installation comply with all applicable local and national codes.*

#### **IMPORTANT**

*The appliance's warranty is not valid until a Meiko Authorized Service Agent performs a Startup and Demonstration on the appliance. This Demonstration should be scheduled after installation.*

Installation of the machine involves the following steps:

- Verifying that the utility connections are present, are appropriate for the appliance, and comply with all applicable local and national codes.
- Unwrapping the appliance (leaving the shipping skid in place for easier movement) and checking for shipping damage.
- Moving the appliance to the installation location, removing the skid, and leveling the feet.
- Connecting the electrical supply.
- Installing the chemical dispensing system.  
For units equipped with the optional dispensing system, this involves connecting the machine's detergent and rinse additive tubes to appropriate dispensers.  
For units without the optional system, the dispensing system installer should follow the manufacturer's instructions AND the instructions in Section 3 of this Manual.
- Connecting the fresh water supply.
- Positioning the drain hose.

- Contacting your Meiko Authorized Service Agent to perform a Startup and Demonstration on the appliance. This step also validates the appliance's warranty.

### 3.2 Requirements Before Installation

Before the installer can uncrate and move the appliance to the installation location, the following conditions **MUST** be met:

- **INSTALLATION AREA REQUIREMENTS**
  - The area **MUST** be frost-free. Freezing temperatures (32°F/0°C or lower) inhibit proper operation and can damage internal components.
  - The area **MUST** have a firm floor surface. It is possible to compensate for uneven flooring by adjusting the feet.
  - The area should be away from appliances, furniture or surfaces that can be damaged by steam. If this is not possible, these items should be protected from the small quantities of steam that are released during normal operation of the machine.
- **UTILITY CONNECTION REQUIREMENTS**
  - Connections must be present and ready for hookup to the appliance. All utility supplies must comply with the electrical information labels, with the information on the serial plate, and with all applicable local and national codes.
  - Electrical leads and the water supply hose (supplied by the customer) must be present.
  - For units without the optional dispensing system, external detergent and rinse additive pumps (if used) should be installed according to the manufacturer's instructions.
  - For units with the optional dispensing system, appropriate dispensers or containers should be installed and ready for connection to the appliance.
- **GENERAL REQUIREMENTS**  
Authorized personnel should be available to perform the actual utility connections.

### 3.3 Uncrating, Positioning and Leveling

1. Remove all shipping and packaging material from the appliance, including supports and wrappings. Leave the shipping skid in place at this time to allow for easier movement to the installation location.
2. Check for shipping damage as described in Section 2, "Transport and Shipping." If damage is present, call Meiko Customer Service at **1-800-868-3840**, providing full details on the customer, serial number and extent of damage present. Meiko will file a freight claim based on this information.
3. Move the appliance to the installation area and remove the skid. Use caution to avoid damaging the appliance or any of its components.
4. Using a spirit level, check that the appliance is level in both directions (front-to-back AND side-to-side). If necessary, level the appliance by rotating the bottom section of each foot.

#### **CAUTION**

The machine **MUST** be level for proper operation.

### 3.4 Accessing the Utility Connections

Water supply and drain connections are located at the lower rear of the machine. The electrical supply enters through a strain relief at the lower rear, but the terminal blocks are accessed from the front of the machine.

To remove the lower front panel:

1. Remove **AND RETAIN** the four (4) screws on the bottom edge of the lower front panel. See Figure 3-1.
2. Slide the panel down and away from the machine to remove it. As you pull the panel away, disconnect the ribbon cable for the Mike 2 controller to avoid damage.
3. The terminal blocks for the main electrical supply and chemical dispensers (if used) are located on the left side of the machine as shown in Figure 3-2.

**Figure 3-1**

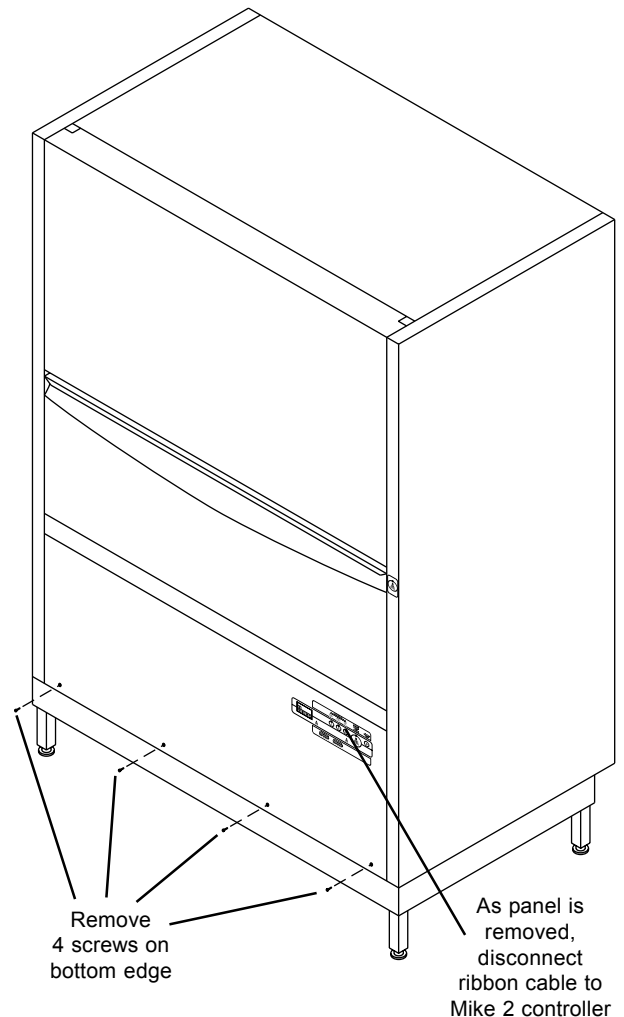

**Figure 3-2**

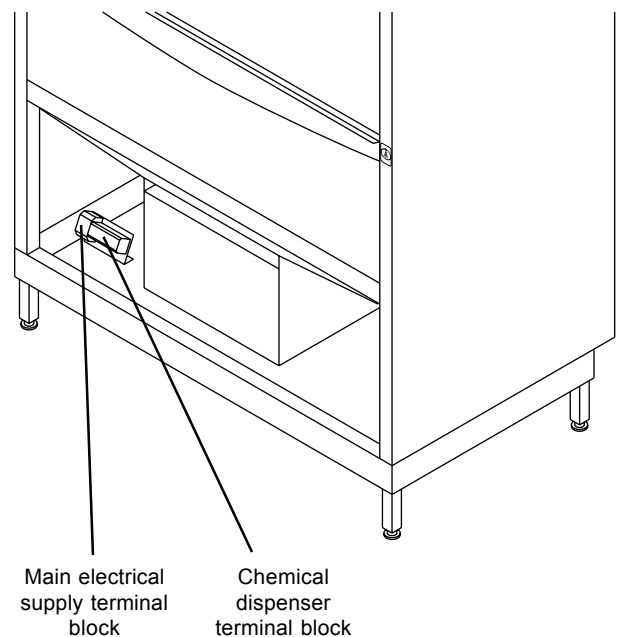

### 3.5 Main Electrical Supply Connection



#### **WARNING!**

Check that the circuit breaker/fused disconnect is in the OFF position and that the unit is switched off before making the electrical utility connections.

#### **IMPORTANT**

In some cases, local codes dictate that electrical supply connections be made only by a certified professional.

1. Check that the incoming power leads are of sufficient rating for the appliance's current draw. Amperage and minimum supply wire specifications are shown on the serial plate and on the electrical information label next to the main terminal block.
2. Check that the incoming power leads are long enough to permit the unit to be repositioned for servicing.
3. Locate the strain relief for the electrical supply wiring at the lower rear of the machine (Figure 3-3). Thread the incoming supply leads through the strain relief and to the main electrical supply terminal block at the front of the machine (Figure 3-4).
4. Refer to Figure 3-5 and the electrical wiring diagram. Connect the power supply and ground leads as indicated.
5. Adjust the strain relief to fasten the wiring in place. You should leave enough slack in the wiring to prevent stress on the terminal connections.

**Figure 3-3: Utility connections**

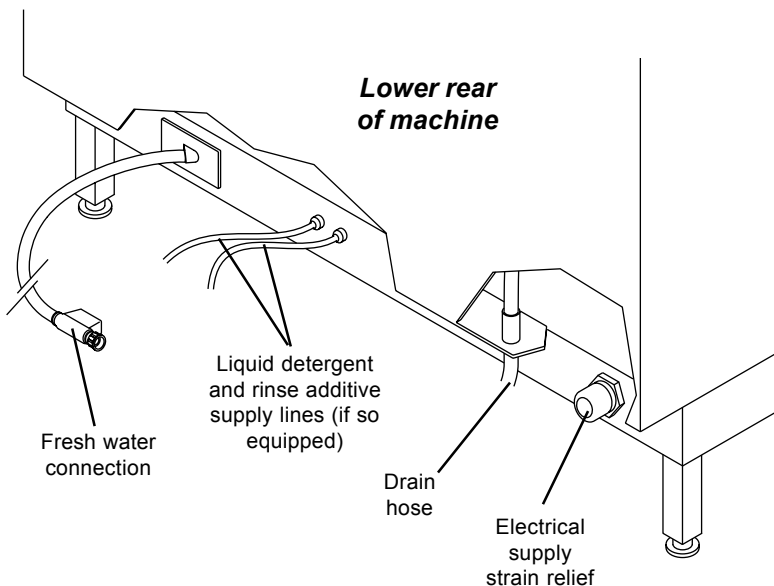

**Figure 3-4: Routing the electrical supply**

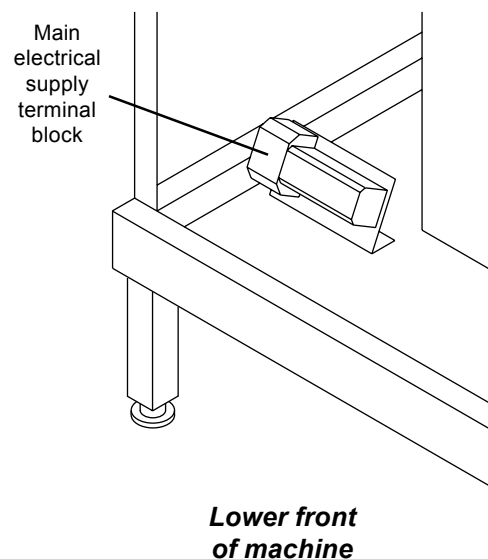

**Figure 3-5: Main electrical supply connections**

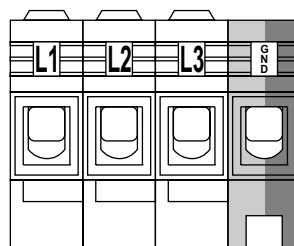

208-230V, 60Hz, 3 Phase  
or  
460V, 60 Hz, 3 Phase  
L1, L2 and L3 "hot" (line)  
yel/grn = ground

### 3.6 Dispensing system overview

The FV 250.2 is designed for use with a liquid rinse aid, and either solid or liquid detergents.

Units equipped with optional liquid internal detergent and rinse aid pumps have two tubes exiting the machine at the lower rear. These tubes can simply be attached to detergent and rinse aid containers. See Figure 3-6.

Units that are NOT equipped with the internal pumps have:

- A blue rinse aid line exiting the machine at the lower rear.
- Two dummy plugs covering holes in the back of the wash tank that can be used for detergent injection. The plugs are accessed by removable panels on the sides of the machine. Either plug can be used.
- A hole in the bottom of the wash tank for the installation of a detergent concentration probe.

A dispensing system terminal block (shown in Figure 3-6) provides contacts for two **line voltage** relays. These relays, when closed, provide a “window” for external pump systems to activate.

- The rinse aid pump relay closes for approximately 16.5 seconds whenever the booster tank refills (once per cycle).
- The detergent pump relay closes whenever the wash pump is in operation.

Activation of the pumps can be controlled as follows:

- Solid detergent systems should use a detergent concentration probe installed in the wash tank to activate the external pump. A dummy plug at the bottom of the wash tank provides an installation location for the probe.

**Figure 3-6: Chemical connections**

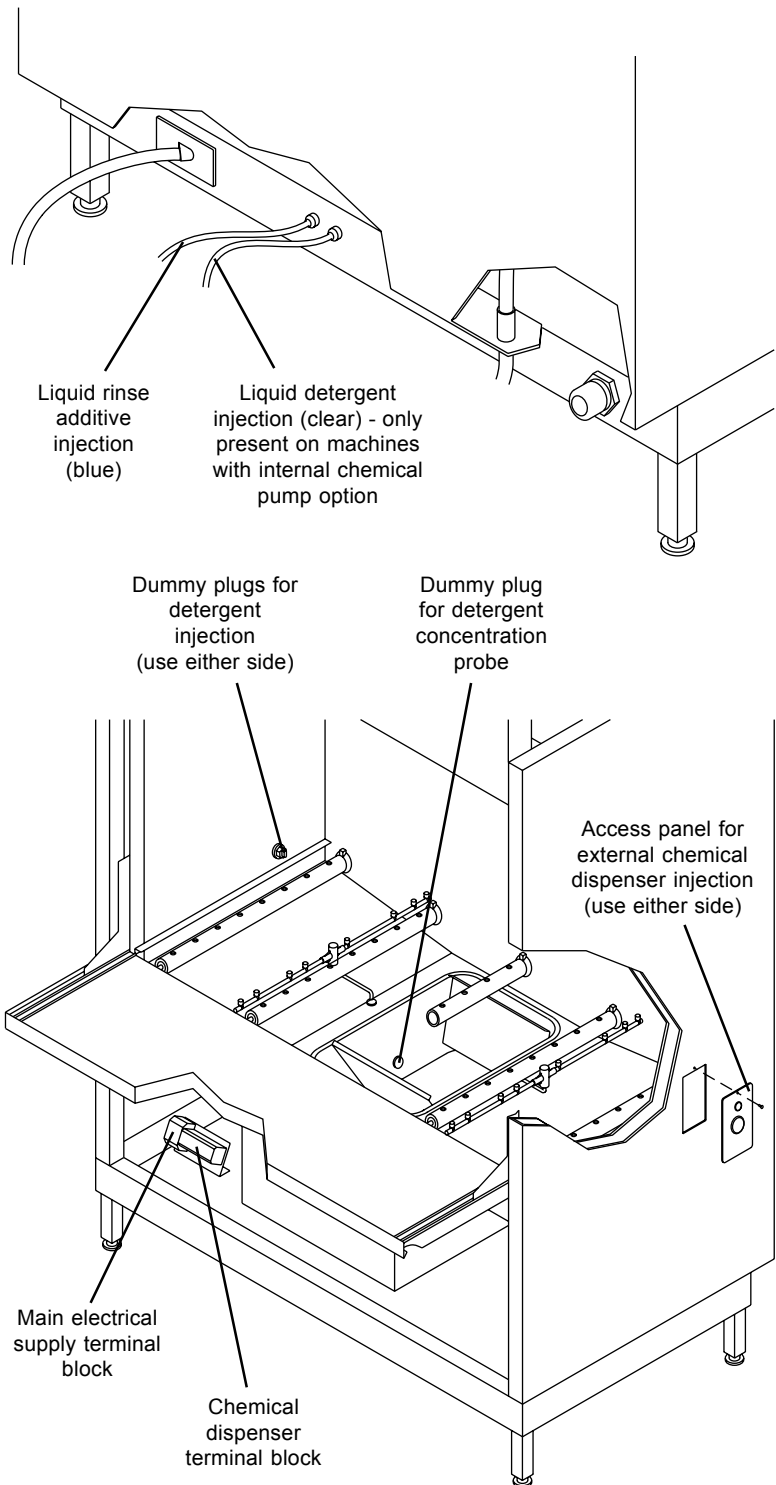

- Liquid detergent systems can use EITHER a detergent concentration probe, OR a timer system. A detergent concentration probe is **HIGHLY RECOMMENDED**.
- Liquid rinse aid systems should be controlled using a timer system.

**CAUTION**

If the unit will NOT use one or both of the chemical supply tubes, cut the unused tube(s) close to the point where it exits the machine's exterior panel and seal it using the supplied plug and wire clamp. See Figure 3-7.

For units equipped with the optional internal chemical dispensing system, skip ahead to Section 3.10, "Connecting Chemical Containers or Dispensers."

### 3.7 Installing an External Detergent System

To install a detergent dispensing system:

1. Remove the detergent plug access panel on either side of the machine. Remove the matching dummy plug from the back of the wash tank. See Figure 3-8.
2. Route the detergent supply line through one of the two holes in the access panel, through the side panel, and into the wash tank. For solid systems, use the large hole in the access panel. For liquid systems, use the smaller hole.
3. Fasten the line in place and seal the connection.
4. Replace the access panel.
5. If a detergent concentration probe will be used, remove the dummy plug in the bottom of the wash tank. Then, install the detergent concentration probe and seal the connection. See Figure 3-8.
6. Check that the pump is correctly installed according to the manufacturer's instructions.

**Figure 3-7: Sealing unused chemical tubes (if not using a liquid detergent or rinse additive)**

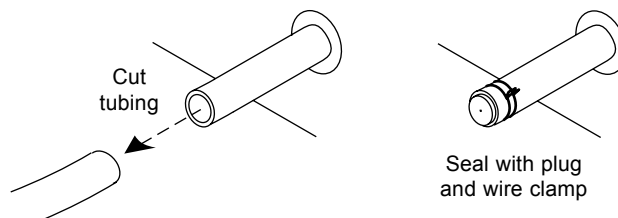

**Figure 3-8: External detergent system**

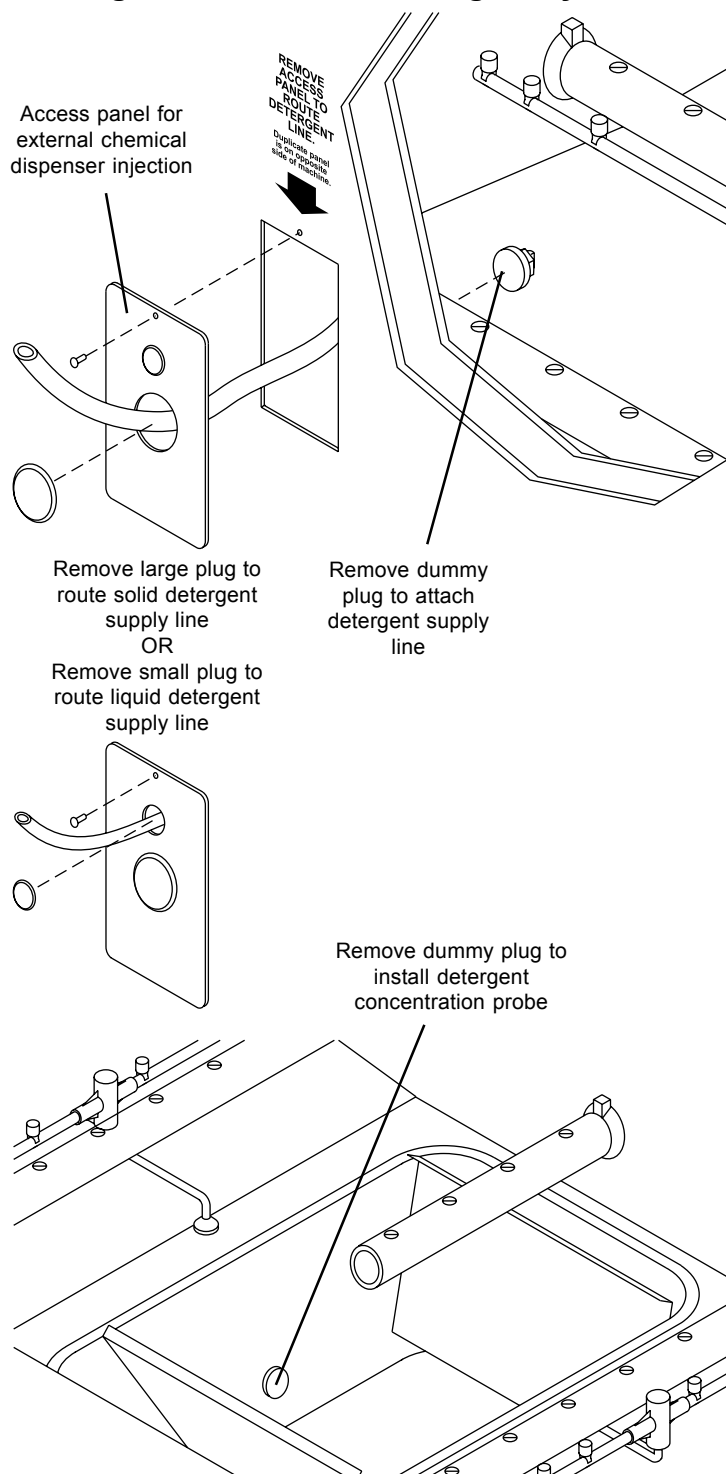



### 3.8 Installing an External Liquid Rinse Aid System

A pre-plumbed, blue 1/4" ID tube at the lower rear of the unit serves as the connection point for the rinse aid supply. See Figure 3-9.

If a liquid rinse aid system will NOT be used, cut the tubing near the rear panel. Then, close and seal it with the plug and wire clamp that are supplied on the end of the tube. See Figure 3-7.

To install a liquid rinse aid dispensing system:

1. Route the rinse aid supply line to the blue 1/4" ID tube at the lower rear of the machine.
2. Fasten the line in place and seal the connection.
3. Check that the pump is correctly installed according to the manufacturer's instructions.

### 3.9 Wiring External Chemical Dispensing Systems

#### **IMPORTANT**

*Some local codes dictate that electrical connections be made only by a certified professional.*

1. Locate the chemical dispenser terminal block. See Figure 3-4.
2. Thread the incoming leads from the chemical pumps through the extra strain reliefs (at the lower rear of machine) and to the chemical dispenser terminal block.
3. Connect the wires as shown in Figure 3-10. Note that the terminal block supplies LINE VOLTAGE SIGNALS. An additional transformer may be required depending on the supply requirements of the external pumps.
4. Adjust the strain reliefs to fasten the wiring in place. Leave enough slack in the wiring to prevent stress on the terminal connections. Bundle the wires together using wire ties to prevent them from tangling when repositioning the appliance.

**Figure 3-9: Liquid rinse additive system**

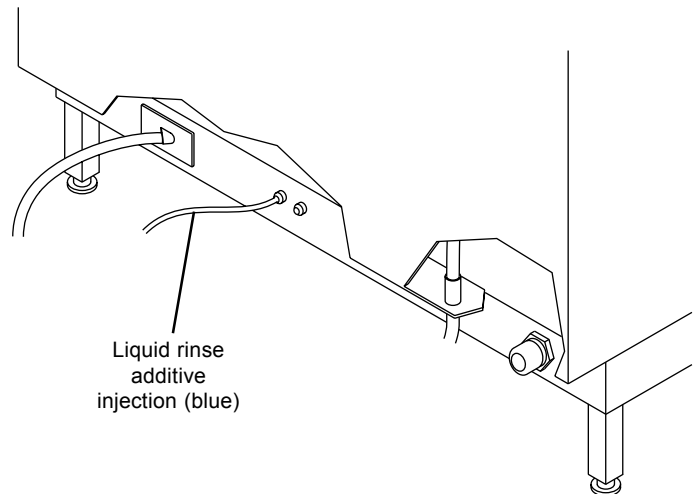

**Figure 3-10: Dispenser pump wiring**

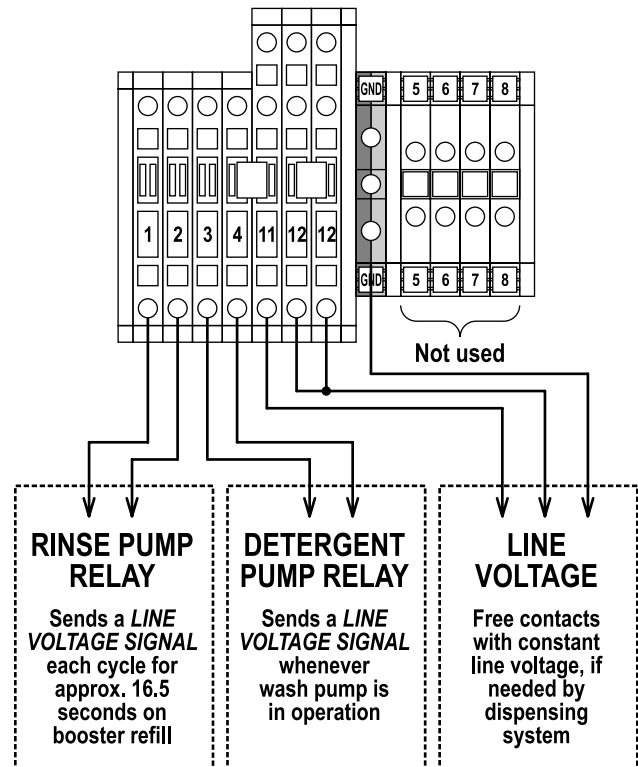

### 3.10 Connecting Chemical Containers or Dispensers (if so equipped)

*This section applies to units with either internal or external chemical dispensing pumps.*

1. Check that the rinse additive and detergent are compatible with the unit. In particular, a commercial (not a domestic) detergent **MUST** be used.
2. Check that the containers/dispensers are correctly installed according to the manufacturer's instructions.
3. If the dishwasher is equipped with factory internal chemical dispensing pumps, two strainer assemblies for the chemical containers are also included. See Figure 3-11. These strainers should be assembled onto the lids for the detergent and rinse additive containers.
4. For liquid detergent systems, locate the CLEAR liquid detergent tube. Connect the tubing to the detergent container.  
For solid detergent systems, connect the detergent supply line according to the manufacturer's instructions.
5. Locate the BLUE liquid rinse additive tube at the lower rear of the unit. Connect the tubing to the rinse additive container.
6. If using the strainers shown in Figure 3-11, be sure to use the supplied wire clamps to fasten the chemical supply tubes securely. Meiko **STRONGLY RECOMMENDS** the use of a sealing compound on these connections to prevent leakage.

**Figure 3-11: Strainer assembly**

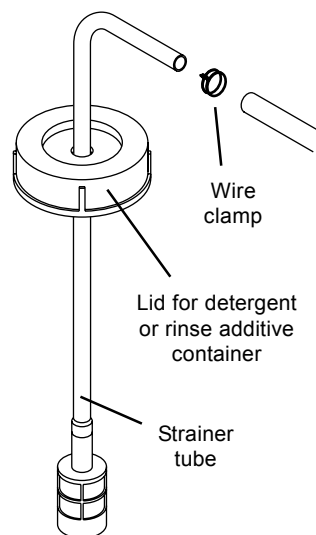

### 3.11 Fresh Water Supply Connection

#### CAUTION

Before connecting the water supply hose, the line **MUST** be flushed clean of all debris, including (but not limited to) pipe sealant, metal particles, solder, etc. This debris can damage the appliance.

#### IMPORTANT

In some cases, local codes dictate that water supply connections be made only by a certified professional.

1. Check that iron or other metal particles cannot contaminate the fresh water supplied to the dishwasher.
2. Check that the incoming water pressure is within the acceptable range for the appliance (8.7-72.5 psi, 0.6-5.0 bars). It may be necessary to increase the pressure (with a booster pump) or to reduce the pressure (with a reducing valve).
3. Check the incoming water temperature. Meiko recommends a water temperature of 140°F/60°C for optimum operation, although if necessary the appliance will operate correctly using water at any temperature of 140°F/60°C or lower. Colder water will result in a longer preheat time (during initial startup) and may extend the cycle time to allow the final rinse water to heat to 180°F/82°C.
4. Check the incoming water hardness. Meiko recommends a hardness of 4 grains per U.S. gallon (7 DH German hardness).

5. Because the water inlet incorporates a stainless steel dirt trap, an additional trap is unnecessary unless required by local, national or international codes.
6. The dishwasher includes a water supply line that ends in an enclosure containing the water inlet valve and the Aqua-Stop shutoff valve (see Figure 3-12). Connect the customer-supplied water line to the fitting on the end of this enclosure. Use a sealing compound on the threads to ensure that no leaks are present in the connection.
7. Check that the water line is long enough to permit the unit to be repositioned for servicing.

### 3.12 Drain Hose Positioning

1. Check that the end of the drain hose will empty into a drain with a minimum diameter of 1-1/2"/38mm.
2. Check the type of drain that will be used. Because the FV 250.2 uses a pumped drain, either a floor or wall drain is acceptable.

#### CAUTION

No portion of a wall drain system may be higher than **24" (610m) A.F.F.** to ensure that the drain pump is operating within rated specifications. See Figure 3-13.

3. Route the drain hose to the drain. In some cases, a grease trap (supplied by others) must be fitted into the waste water line. If this trap is required for your installation, check that it is present.

**Figure 3-12: Fresh water supply and drain connections**

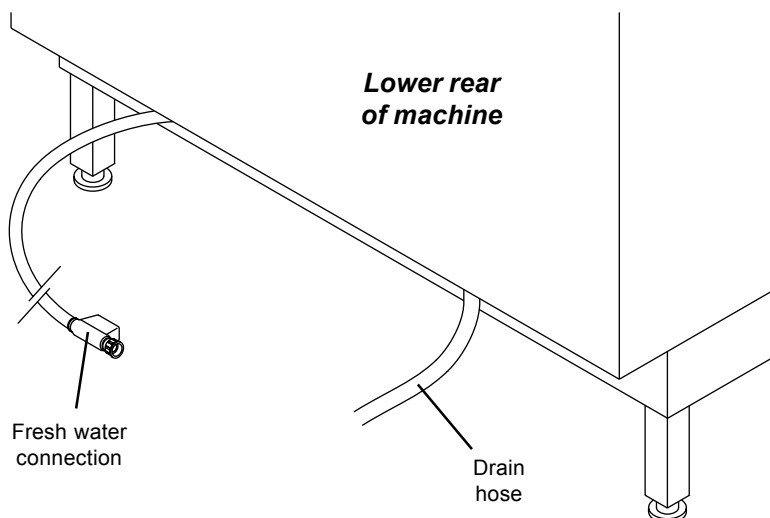

**Figure 3-13: Drain line vertical rise limitations**

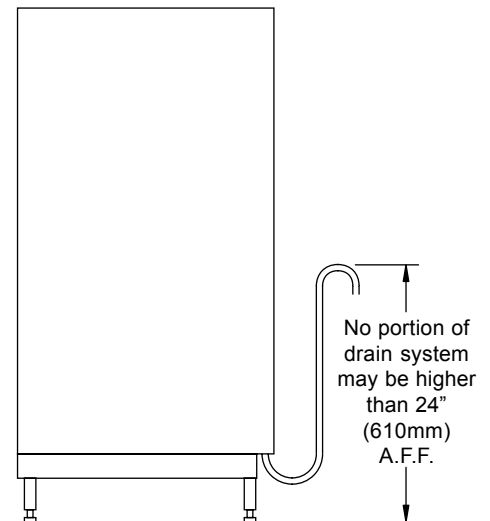















### 3.13 Final Assembly

1. Check and tighten all electrical terminal screws.
2. Replace all panels onto the machine.
3. Switch the circuit breaker/fused disconnect to the ON position. Be sure to prime the detergent pumps and check for correct chemical concentration before operating the unit.

### 3.14 Priming the Detergent and Rinse Additive Lines

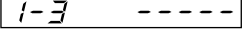
For machines equipped with external chemical dispensing systems, prime the detergent and rinse additive lines according to the manufacturer's instructions.

For machines equipped with factory internal chemical dispensing systems, prime the lines as follows:

1. Press and hold the  key until  appears in the display (about 4-5 seconds).
2. Press the  key 5 times until  appears in the display.
3. Press the  key.  will appear in the display.
4. Press the  key to start priming the liquid rinse additive lines. A timer will count down the time remaining. By default, the system will prime for 180 seconds.
5. When the display returns to , press the  key so that  appears in the display.
6. Press the  key to start priming the liquid detergent lines. A timer will count down the time remaining. By default, the system will prime for 30 seconds.
7. When the display returns to , press the  key to shut off the dishwasher.

### 3.15 Checking for Correct Chemical Concentration

Machines equipped with external chemical dispensing systems will have normal settings recommended by the manufacturer.

For machines equipped with factory internal chemical dispensing systems, the normal settings for chemical injection are:

- Detergent - 0.256 oz. per gallon of wash water (2.0 ml per liter).
- Rinse additive - 0.0256 oz. per gallon of rinse water (0.2 ml per liter).

To check if the normal settings are correct for your chemicals, *RUN THREE EMPTY LOADS* to completely cycle the water supply and obtain accurate test results. This will only take a few minutes. Then, run a sample load with soiled ware and examine the results.

- If the detergent setting is too low, the ware will not be adequately cleaned. In some cases, this can be corrected by simply selecting a longer cycle time (using the Cycle Select II, Extended or Cycle Select III, Heavy buttons), but the detergent concentration may also need to be adjusted.
- If the rinse additive setting is too low, spotting or streaking may occur on the ware.
- If too much of either chemical is added, the extra chemicals will be wasted. This is often difficult to detect except by determining how long your chemical supplies last. If the chemicals are being exhausted quickly, you may need to have the chemical concentration adjusted.

**IN ALL CASES, ANY ADJUSTMENTS OF THE FACTORY CHEMICAL INJECTION SETTINGS ARE TO BE PERFORMED ONLY BY A MEIKO AUTHORIZED SERVICE AGENT. CHANGES BY UNAUTHORIZED PERSONNEL WILL VOID YOUR WARRANTY.**

If you need to contact your Authorized Service Agency, please contact Meiko Technical Support at **1-800-868-3840**.

## 4 OPERATION

### 4.1 Location and Description of Controls

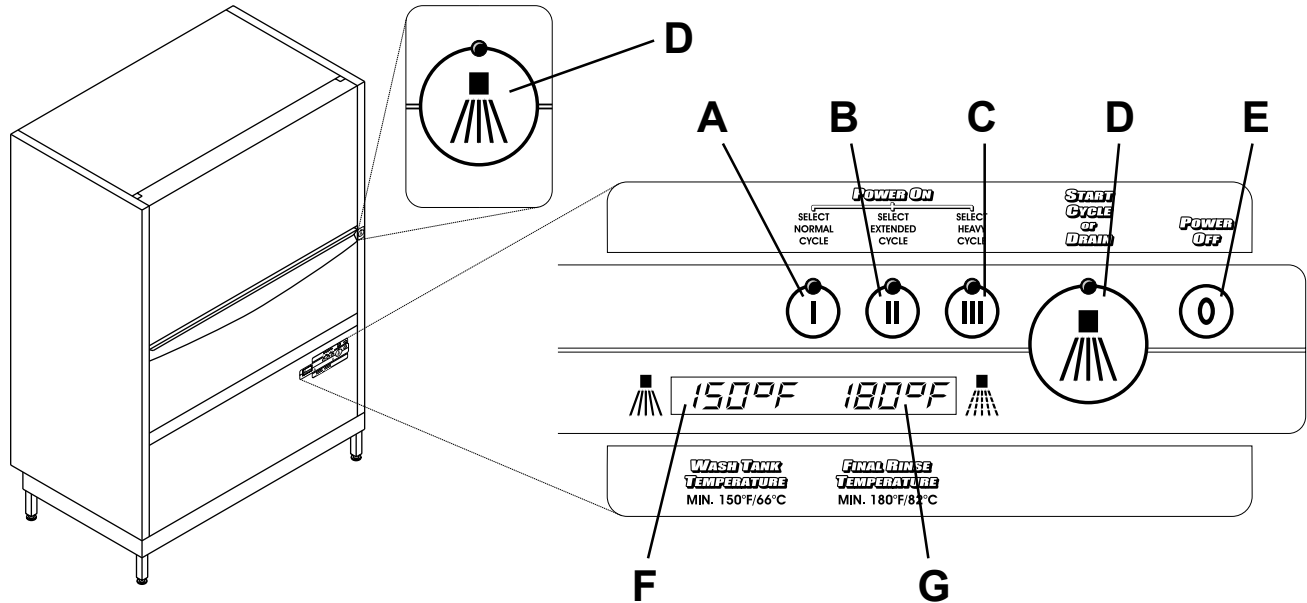

The machine controls are located on two keypads on the front panel. See Figure 4-1.

Figure 4-1: Dishwasher controls



#### A, B, C - POWER/CYCLE SELECT keys

These keys turn the machine on. Each key selects a different cycle length to accommodate differing levels of soiling:

-  Normal cycle (4 minutes) for plates, glassware and typically soiled pots, pans and utensils
-  Extended cycle (6 minutes) for items with heavier soiling
-  Heavy cycle (8 minutes) for items with very heavy soiling

The keys may also be pressed between cycles to choose a different cycle length.

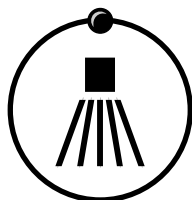

#### D - CYCLE/DRAIN key

If pressed when the unit is ready to operate, this key starts the operating cycle. If the machine has been switched off (for instance, at the end of the shift), this key empties the tank. There are two Cycle/Drain keys on the front of the machine. Both keys function identically.

#### E - POWER OFF key

 If pressed when the unit is in operation, this key ends the cycle immediately. If the unit is NOT in operation, this key will switch the unit off.

#### F - WASH TANK TEMPERATURE display

 Shows the current temperature of the water in the wash tank.

#### G - FINAL RINSE TEMPERATURE display

 Shows the current temperature of the final rinse water. The machine cannot begin a rinse cycle until the rinse water has heated to the proper temperature. The wash cycle will automatically extend (if necessary) until the proper rinse temperature is reached.

## 4.2 Startup

Check the level of the external detergent and rinse additive dispensers. If necessary, replace or refill the dispensers.

Press any of the three POWER/CYCLE SELECT keys to turn on the machine.



**Normal cycle** for plates, glassware and typically soiled pots, pans and utensils



**Extended cycle** for items with greater soiling



**Heavy cycle** for very heavily soiled items

(flashing)



The light above the selected POWER/CYCLE SELECT key will begin to flash, showing that the tank is filling and the water is heating to the correct temperature.

The time required for filling and preheating will vary based on the temperature of the incoming water supply. For incoming water at 140°F/60°C, the machine may need up to 15 minutes to fill and heat to the correct wash temperature. The default wash temperature is several degrees above 150°F/66°C for efficient operation.

OPTIONAL

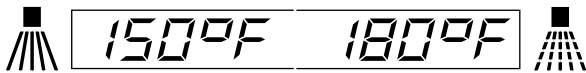

If desired, you can watch the WASH TANK TEMPERATURE and FINAL RINSE TEMPERATURE displays as they rise. This gives an indication of the amount of time left before the machine can be operated.

(constant)



When the tank is full and the water has been heated to the correct temperature, the light above the selected POWER/CYCLE SELECT key will stop flashing. The machine is now ready for operation.

## 4.3 Loading

The loading guidelines shown here will lead to faster, more efficient cleaning of your ware.

Load sheet pans, trays, etc. at an angle with the inside face pointing up. Use the triangular sheet pan support insert for these items for faster loading, and to ensure that the ware is positioned and spaced properly for effective washing.

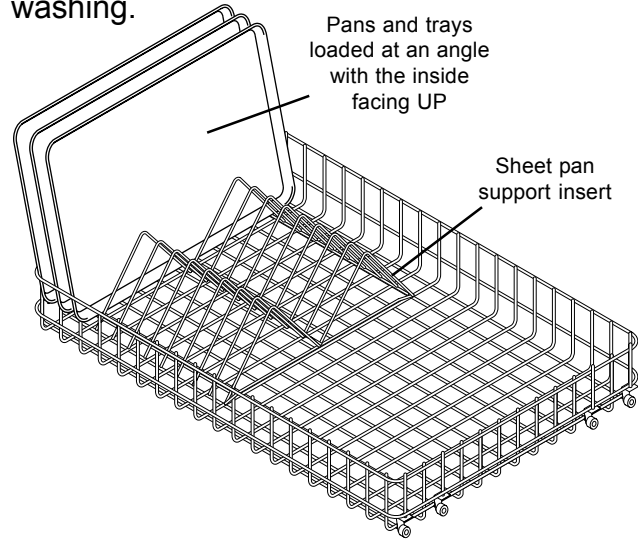

Load pots, bowls or deep pans with the open side facing down. If items are too light to stay in position, place the chain mesh on top of them to prevent movement during the wash cycle.

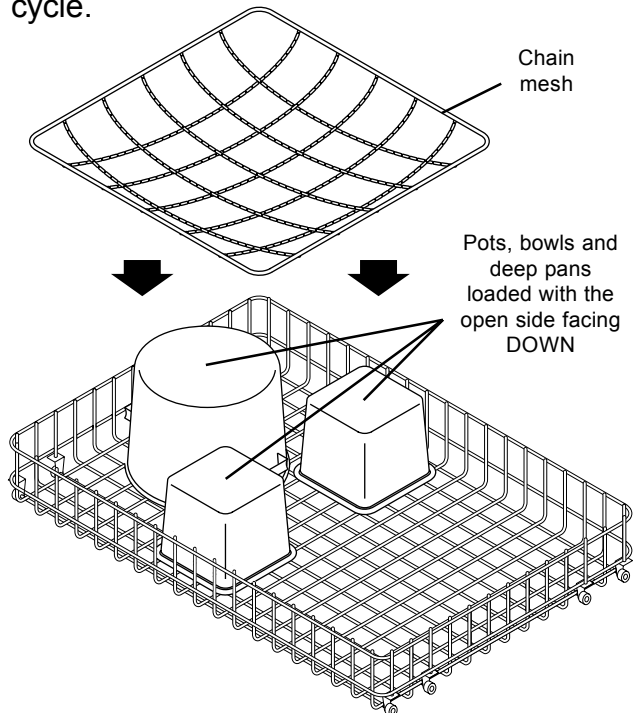



Plates, soup bowls, and glassware can be loaded into the machine using standard 20x20" racks. The FV 250.2 wire basket holds two racks.

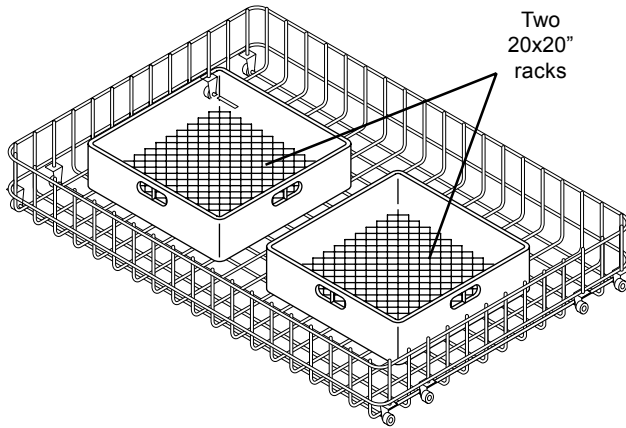

When loading 20x20" racks, load plates, soup bowls, etc. at an angle with the inside face pointing up. Ensure that water cannot pool in the bottom of bowls. Loading bowls face-up reduces the possibility of movement during the wash cycle.

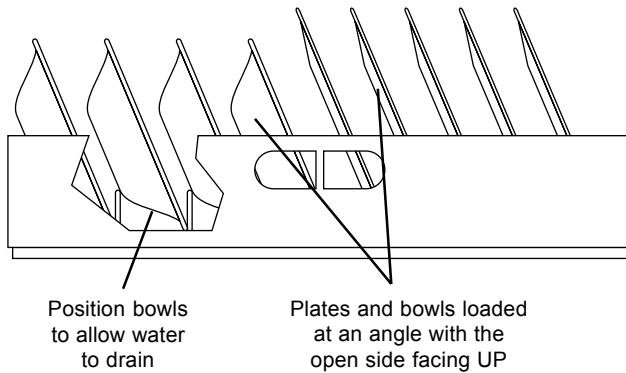

Glasses should be loaded with the open side facing down, using EITHER a rack with a hold-down grid, OR a tall, compartmentalized rack intended for glassware, to prevent movement during the wash cycle.

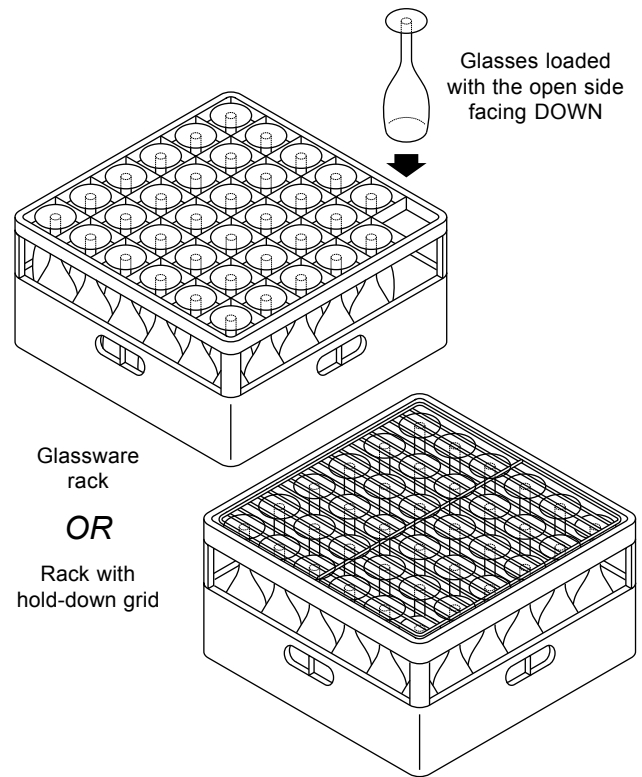

For greater efficiency in loading cutlery, you can use cutlery holders. When loading them:

- Do not overload the holders.
- Always load knives, forks and spoons with the handle DOWN.
- Do not load identical ware into any given holder. Instead, load an assortment of knives, forks and spoons into each holder. Identical ware is often too closely spaced for effective cleaning.

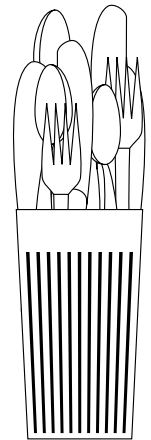

Do not stack items in the machine. Stacked items require longer or multiple cleaning cycles because the wash water cannot reach the food residue as effectively.

After loading, roll the basket completely into the machine. Then, lift the lower door section to close the split doors.

## 4.4 Operation

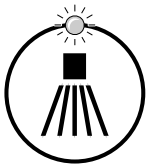

Press either of the CYCLE/DRAIN keys to begin the selected cycle. The key will not work unless the light above the selected POWER/CYCLE SELECT key has stopped flashing.

The machine will begin a wash and rinse cycle. The **Soft Start** feature pumps the water through the arms slowly for the first few seconds of the cycle to protect fragile ware. After a few seconds, full pressure will engage.

The time of the total cycle will be at least as long as the times shown in Section 4.1. Note that quickly loading several loads in succession when using a cold water supply may extend the cycle time.

### OPTIONAL

If desired, the cycle can be stopped at any time by pressing the POWER OFF (0) button OR by opening the door.



### WARNING!

*If the door is opened suddenly, hot water can spray out of the machine. To prevent this from happening:*

- *Open the door slowly until the machine stops operating, OR*
- *Press the (0) key to stop the wash/rinse cycle before opening the door.*

When the cycle has completed, the machine will stop operating and sound a three-stage beeping tone. After the tone has sounded, you may open the doors, roll the basket forward onto the lower door section, and unload the ware. Note that steam escapes when the doors are opened; this is normal.



### WARNING!

*Use caution when handling hot dishware.*

## 4.5 Between Cycles

During idle periods, leave the doors of the machine closed. If the doors are left open, the wash tank water will cool. This will activate the tank heaters, consuming extra energy, and may lengthen the recovery time when another cycle is started.

If necessary, you can choose a different cycle length between cycles by pressing any of the POWER/CYCLE SELECT keys.

When you are ready to start a new cycle, refer to Section 4.3, "Loading."

## 4.6 Shutdown



At the end of the shift, press the POWER OFF key.

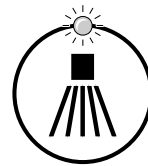

Press either of the CYCLE/DRAIN keys to empty the tank.

After the water has drained, the machine will enter a self-cleaning mode. The interior will be sprayed with hot, fresh water as the booster tank empties. When this is completed, the drain will "pulse" several times to empty the water and the machine will automatically shut off.



### WARNING!

*DO NOT open the doors of the machine during the self-cleaning process! The process will be interrupted and hot water may spray out of the machine.*

After the machine has finished its self-cleaning cycle, open the doors. Remove any food particles, scraps or bones from the scrap screen. Meiko recommends that the doors of the machine be left open overnight to allow it to air thoroughly.

### IMPORTANT

Because of the large quantity of food soiling present on many pots and pans, it is **STRONGLY RECOMMENDED** that the interior of the machine be cleaned daily following the instructions in Section 5.1, "Daily Cleaning."



## 5 CLEANING



### WARNING!

Before ANY cleaning, check that the circuit breaker/fused disconnect is in the OFF position and that the unit is switched off.

### IMPORTANT

The headings *Daily Cleaning* and *Weekly Cleaning* in this section are general recommendations based on typical soiling.

Because of the large quantity of food soiling present on many pots and pans, it may be necessary to clean the machine more often and more extensively than a traditional dishwasher. Extensive food soil deposits inside the machine work against optimal performance. Some items may not be cleaned as effectively, resulting in the need for either a longer cycle or repeat washing. In addition, heavy soiling in the wash water increases detergent consumption.

### 5.1 Daily Cleaning (or as required)

1. The machine automatically enters a self-cleaning cycle when it is turned off. The interior will be sprayed with hot, fresh water as the booster tank empties.
2. AFTER this cycle ends and the machine shuts down, open the doors, and remove the basket from the machine. Any food soil clinging to corners, etc. of the basket can be wiped off with a clean, damp cloth.
3. Remove the lower center wash arm to access the scrap screen and wash tank. To remove the arm, first pull its front side up and out of the black retainer bar. Then, pull the back side free of the manifold.
4. Remove any large food particles, scraps or bones from the scrap screen.
5. Lift out the scrap screen and clean it thoroughly using a brush and warm water.
6. Flip up the two angled plates that surround the Active Plus filter.
7. Lift out the Active Plus filter. Clean it thoroughly using a brush and warm water. Be sure to use care to avoid damaging the screen on the Active Plus filter.

**Figure 5-1: Daily cleaning disassembly**

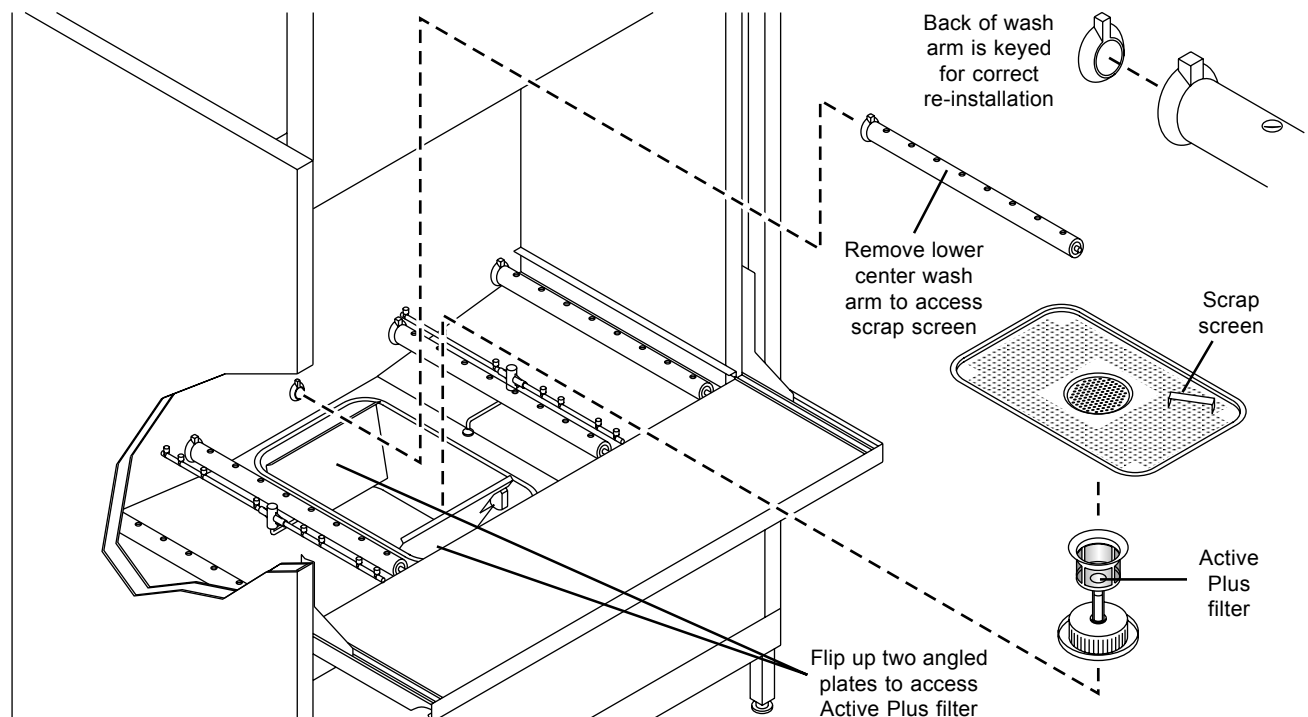

8. Check the inside of the wash tank for food particles. Wipe any residue out of the tank using a clean, damp cloth.
9. Meiko recommends that the doors of the machine be left open overnight to allow it to air thoroughly.
10. Reassemble all components into the machine before operation. Note that the Active Plus filter **MUST** be re-installed with the slotted end facing **DOWN**. See Figure 5-1.

### **IMPORTANT**

Be sure to flip down the two angled plates that surround the Active Plus filter before replacing the scrap screen!

To replace the wash arm, first insert the back end into the manifold. The back end of the arm is keyed to ensure correct replacement. Then, snap the front end down into the black retainer bar.

## **5.2 Weekly Cleaning (or as required)**

Once per week, or as required, perform the following steps:

1. Follow the procedures in Section 5.1, "Daily Cleaning."

2. Remove and disassemble the wash and rinse arms. The machine is equipped with:
  - Five upper wash arms (identical)
  - Five lower wash arms (identical)
  - Two removable upper rinse arms (identical)
  - Two removable lower rinse arms (identical)
  - Two additional fixed lower rinse arms (leave these in place)

All four removable rinse arms are identical. The upper wash arms are slightly shorter than the lower arms to prevent their re-installation in the wrong location.

The lower wash arms are removed in the same manner as the lower center arm (see Section 5.1, "Daily Cleaning.") To remove the upper wash arms, first pull the front side of the arm down and out of the black retainer bar, and then pull the back side free of the manifold.

To remove the rinse arms, remove the retaining screw and pull the arm off the shaft.

3. Clean the wash and rinse arms with a brush and warm running water. In particular, check that any food soil inside the wash arms is removed.
4. Reassemble all components into the machine.

**Figure 5-2: Wash and rinse arm disassembly**

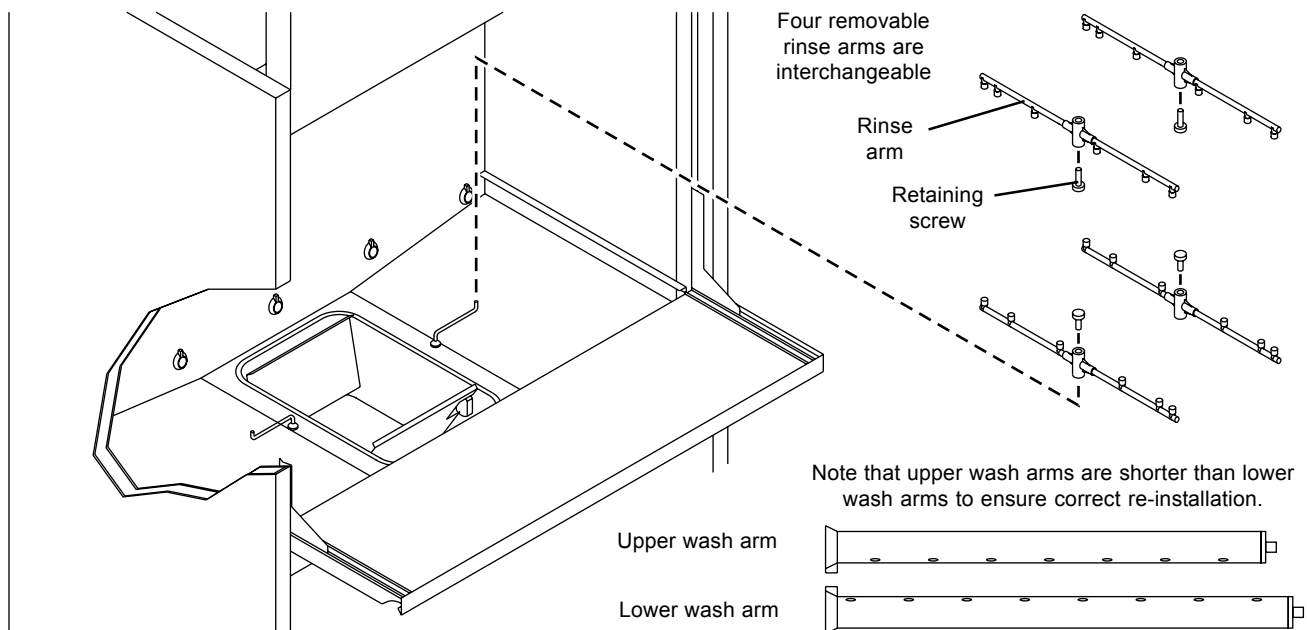

### 5.3 Exterior cleaning (as required)

#### **CAUTION**

*When cleaning the exterior of the machine, be sure to follow these guidelines:*

- Meiko strongly recommends using detergent when cleaning the exterior of the unit, instead of commercial stainless steel cleaners. These cleaners can damage the surface of the control panel.
- Never use abrasive cleaners or pads when cleaning the exterior of the machine. These can scratch the surface of the unit.



#### **WARNING!**

*Ensure that detergents and stainless steel cleaners are kept out of the interior of the machine. If the interior of the unit requires cleaning, refer to the delimiting procedures (Section 5.4).*

### 5.4 Delimiting (as required)

Lime scale deposits will occur over time on the interior of the machine if it is operated using a hard water supply. Meiko recommends a hardness of 4 grains per U.S. gallon (7 DH German hardness).



A delimiting or de-scaling process can be used to remove these deposits, as well as any accumulated food residue.

#### **CAUTION**

*When delimiting the interior, be sure to follow these guidelines:*

- Use delimiting agents designed for use with commercial dishwashers.
- Follow the instructions for the delimiting agent that is used.

After the delimiting process:

1. Run the machine through 2-3 regular cycles without a load to rinse and sanitize the interior thoroughly.
2. Inspect the interior for any remaining delimiting agent residue. If residue is present, remove it using a soft cloth and hot water; then, run the machine through one final empty cycle.
3. Press the POWER OFF  button; then, press the CYCLE/DRAIN  button. This will empty the tank, ensuring that any delimiting agent still in the tank will be flushed out of the machine.



#### **WARNING!**



*Ensure that ALL residue of the delimiting agent is removed. Residue from the agent can:*





- Pose a health hazard;
- Damage seals and plastic components inside the machine.

## 6 TROUBLESHOOTING

If the machine encounters a problem, an Info Code or Error Code will usually appear in the display. If you use this troubleshooting guide to resolve simple problems, you can often return the appliance to operation faster than placing a service call.

Info Codes appear for minor difficulties. Error codes appear for more complex issues. After correcting the condition, if the unit does not return to normal operation automatically, press

 or  to clear the message.

<i>Display Shows</i>	<i>Problem</i>	<i>Action</i>
	Tank is not heating OR fresh water is not entering unit	Check that the water hose is correctly attached and is free of “kinks” or pinching. Also check that the water supply is turned on.
	Door is not closed OR door switch is defective	Check that the door is completely closed.
	Water leakage onto floor pan	Check that the water line to the unit is not leaking, and that the drain hose empties correctly into the floor drain.
	Correct water level was not reached during initial filling	Check that the water hose is correctly attached and is free of “kinks” or pinching. Also check that the water supply is turned on.
	Filling process takes too long	Check that the water hose is correctly attached and is free of “kinks” or pinching. Also check that the water supply is turned on.

**You should contact your Meiko Authorized Service Agent IF:**

- ***The machine encounters a problem but does not display an error code, OR***
- ***An error code appears that is not shown here, OR***
- ***The listed action fails to correct the problem.***

**An Authorized Service Agency Listing was supplied with your machine. If you do not have the listing, call 1-800-868-3840 for assistance.**







# *If you need service...*



Meiko warewashers are designed for solid reliability as much as for outstanding ware-cleaning ability. With proper care, your warewasher should provide years of trouble-free operation.

If service is necessary, contact your local Meiko Authorized Service Agent. With factory training, OEM parts and direct support from the factory, Meiko's nationwide service network is highly qualified to quickly restore your warewasher to regular operation.

**An Authorized Service Agency Listing is supplied with this Manual. If you do not have the listing, call 1-800-868-3840 for assistance.**



**Meiko**  
917 Airpark Center Drive  
Nashville, TN 37217  
Phone: (615) 399-6600  
(800) 55-MEIKO  
Fax: (615) 399-6620