

Parts Manual

for domestic, CE and standard export ovens

Serial Number Code:

Models w/adjustable conveyor
belt feature are serial
051471006 and higher

First Four Digits - Order Of Production
Fifth Digit - Model Specific
Sixth & Seventh Digit - Month of Production
Eight & Ninth Digit - Year of Production
017070405 - Starting Serial Number and Higher

Serial Tag
Location

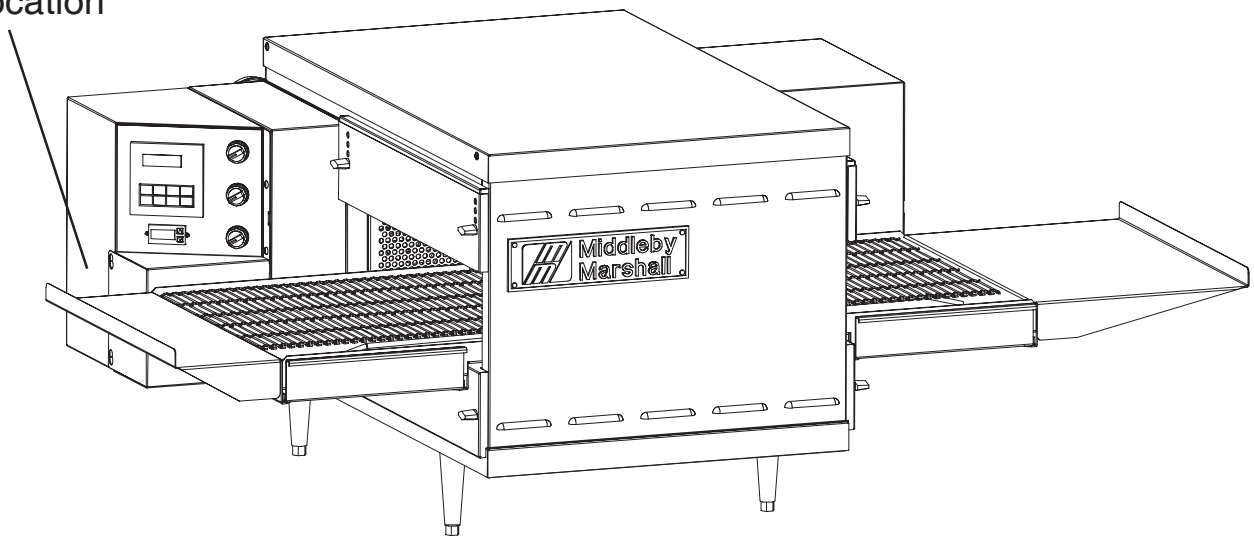
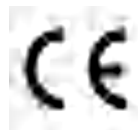

Table Of Contents: Page III



www.middleby.com

email: techsupport@middleby.com
1400 Toastmaster Drive • Elgin, IL 60120
phone: 847-741-3300 • fax: 847-741-4406

WARNING
FOR YOUR SAFETY, DO NOT STORE OR
USE GASOLINE OR OTHER FLAMMABLE
VAPORS AND LIQUIDS IN THE VICINITY OF
THIS OR ANY OTHER APPLIANCE.

WARNING
Improper installation, adjustment, alteration,
service, or maintenance can cause property
damage, injury, or death. Read the
installation, operating, and maintenance
instructions thoroughly before installing or
servicing this equipment.

NOTICE
The warranty is NOT VALID unless the oven is installed, started, and demonstrated under the supervision of a factory-authorized installer

NOTICE
Contact your authorized Service Agency to perform maintenance and repairs. A Service Agency Directory is supplied with your oven.

NOTICE
Using any parts other than genuine Middleby Marshall factory-manufactured parts relieves the manufacturer of all warranty and liability.

NOTICE
Middleby Marshall (Manufacturer) reserves the right to change specifications at any time.

KEEP THIS MANUAL IN A VISIBLE LOCATION NEAR THE
OVEN FOR FUTURE REFERENCE.

TABLE OF CONTENTS

Oven Specifications	1
Oven Dimensions	2
Installation Kit	3
Key Spare Parts	4
Front view of oven	5
Parts for front view of oven	6
View of right hand of electrical compartment	7
Parts for right hand electrical compartment	8
Rear-view blower compartment	9
Parts for rear-view blower compartment	10
View of left hand electrical compartment	11
Parts for left hand electrical compartment	12
View of conveyor parts	13
Parts for conveyor	14
View of mobile cart	15
Parts for mobile cart	16
Standard Finger placement and part number	17

WIRING DIAGRAMS

208/240V Domestic USA/Canada - 48713J	18
380/480V Domestic USA/Canada - 52445J	19
230/240V CE, 1 Phase - UK,FR,GM,IT,SP - 52446K	20
380/400V CE, 1 Phase - UK, FR, GM, IT, SP - 54661J	21
380/400V CE, 3 Phase - High Leg - 58158F	22

PS520 SERIES OVEN SPECIFICATIONS

Conveyor Belt Width	18.00" (457mm)
Heating Zone Length	20.00" (5098mm)
Baking Area Square Feet	2.5 sq ft (.023 sq. m.)
Overall Dimensions	
Standard Single Oven w/Legs	42.00" (1067mm) L x 35.21" (894mm) W x 21.72" (786mm) H x
Overall Dimensions	
Double Oven	42.00" (1067mm) L x 35.21" (894mm) W x 37.27" (947mm) H x
Overall dimensions	
Triple Oven	42.00" (1067mm) L x 35.21" (894mm) W x 52.82" (1342mm) H x
Weight of Single Oven	250 lbs (93.3kg)
Shipping Weight	325 lbs (121.3kg)
Operating Range	8.3 kW/hr
Maximum Operating temperature	550°F (287°C)
Warm-up Time	20 min.
Belt Speed Limits	1-10 minutes

SERIES PS520 ELECTRICAL SPECIFICATIONS

	Main Blower & Elements Voltage	Control Circuit Voltage	Phase	Frequency	Amperage Draw	Poles	Wires
All Models	208-240V	208-240V	1 Ph	50/60 Hz	See Below	2 Pole	3 Wire (2 hot, 1 grd)
					Heater Amperage		
					Voltage kW Amp		
					208 8.3 39.9		
					230 7.6 33.0		
					240 8.3 34.6		
Non-CE	380V	230-240V	1 Ph	50/60 Hz	See Below	3 Pole	4 Wire (2 hot, 1 neut, 1 grd)
					Heater Amperage		
					Voltage kW Amp		
					380 8.3 21.8		
Domestic/Non-CE	480V	208-240V	1 Ph	50/60 Hz	See Below	3 Pole	4 Wire (2 hot, 1 neut, 1 grd)
					Heater Amperage		
					Voltage kW Amp		
					480 8.3 17.3		
CE Only	380-400V	230-240V	1 Ph	50/60 Hz	See Below	2 Pole	3 Wire (2 hot, 1 grd)
					Heater Amperage		
					Voltage kW Amp		
					380 8.3 21.8		
					400 8.3 23.0		
			3 Ph	50/60 Hz	See Below	4 Pole	5 Wire (3 hot, 1 neut, 1 grd)
					Heater Amperage		
					Voltage kW L1 L2 L3 N		
					380 8.3 21.8 21.8 1.2 1.2		
					400 9.2 23.0 23.0 1.2 1.2		

Figure 2-5. MODEL PS520 SINGLE OVEN DIMENSIONS

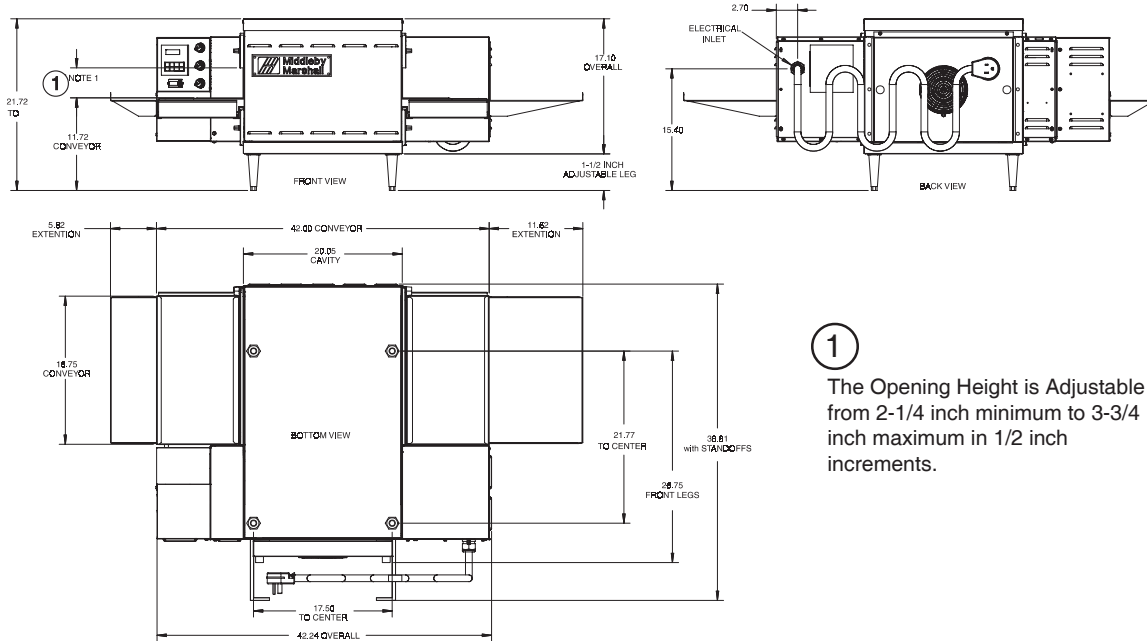

Figure 2-6. MODEL PS520 DOUBLE OVEN DIMENSIONS

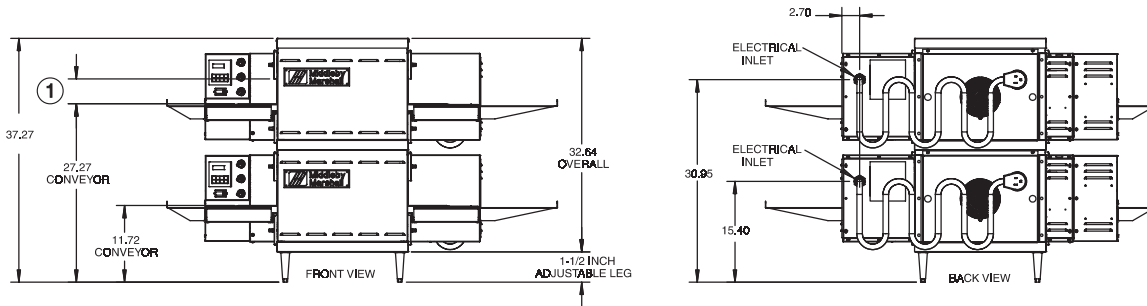
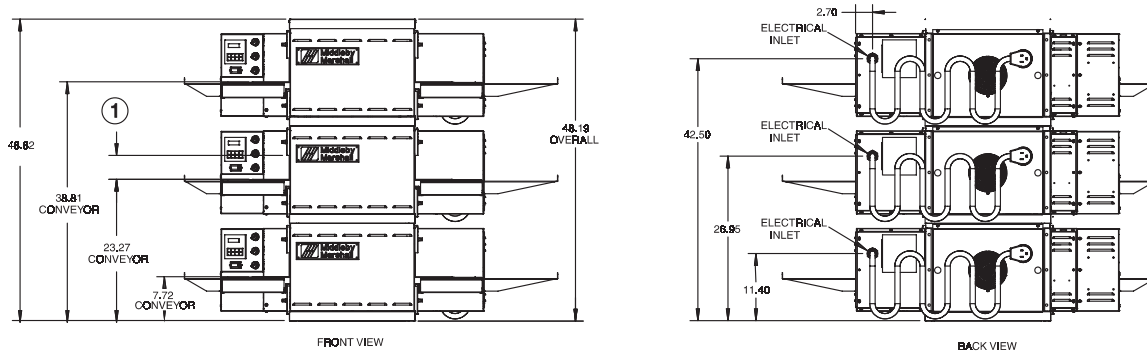
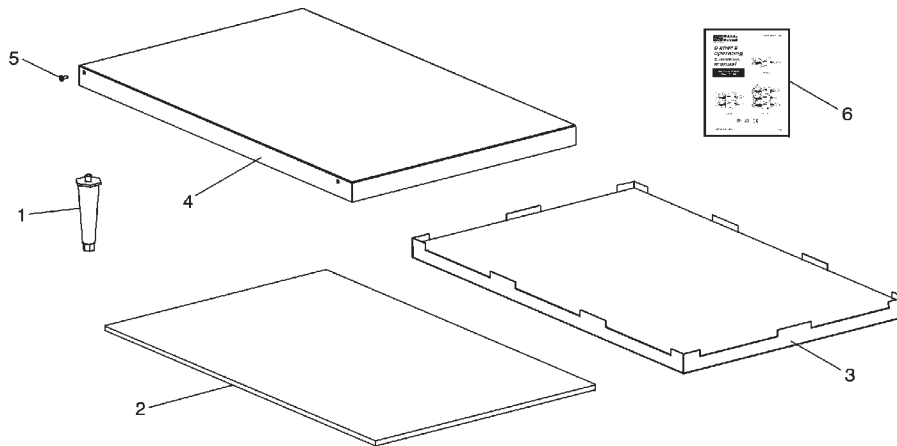

Figure 2-7. MODEL PS520 TRIPLE OVEN DIMENSIONS



**PARTS LIST FOR SERIES PS520 ELECTRIC OVEN
INSTALLATION KIT
Single and Double Stack Ovens
P/N 48397**

Item NO.	QTY	PART NO.	DESCRIPTION
1	4	3101908	Leg 4" AD FT
2	2	48392	Insulation Bottom Tray
3	1	48394	Bottom Tray Weldment
4	1	48396	Top cover
5	4	51387	Screw MSSLT Thread 8-32 x 1/2, 18-8
6	1	52358	Installation & Operation Manual - English
6	1	59476	Installation & Operation Manual - French



**PARTS LIST FOR SERIES PS520 ELECTRIC OVEN
INSTALLATION KIT
Triple Stack Ovens
P/N 54593**

Item NO.	QTY	PART NO.	DESCRIPTION
1	2	48392	Insulation Bottom Tray
2	1	48394	Bottom Tray Weldment
3	1	48396	Top cover
4	4	51387	Screw MSSLT Thread 8-32 x 1/2, 18-8
5	4	M3828	Pin, Alignment
6	1	52358	Installation & Operation Manual - English
6	1	59476	Installation & Operation Manual - French

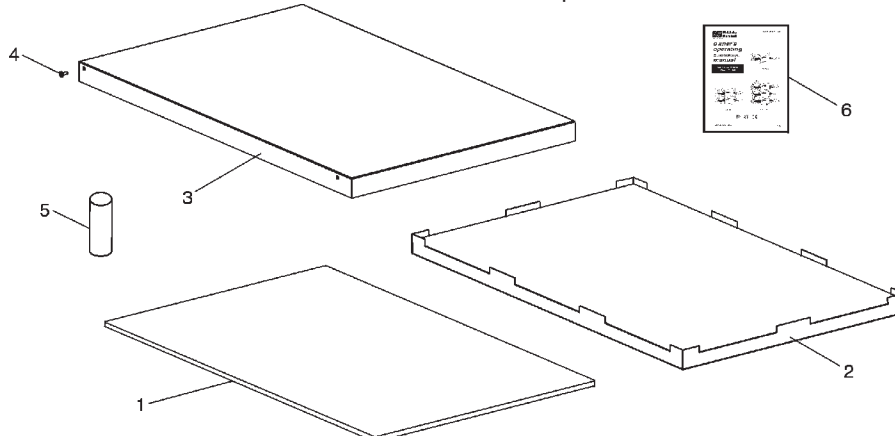

PS520-SERIES ELECTRIC OVEN KEY SPARE PARTS KIT

ITEM	PART NO.	DESCRIPTION	QUANTITY
1	47321	Kit, Temperature Control On/Off PID (58504)	1
2	51402	Relay, 100A	1
3	58390	Conveyor Drive Motor with 2 pole magnet	1
4	58323	Conveyor Speed control	1
5	33812-5	Thermocouple	3
6	50715	Heater Element, 208V	1
6	51017	Heater Element, 240V	1
6	51958	Heater Element, 380V	1
6	51961	Heater Element, 480V	1
7	57408	Contactors 65 amp 3-pole	1

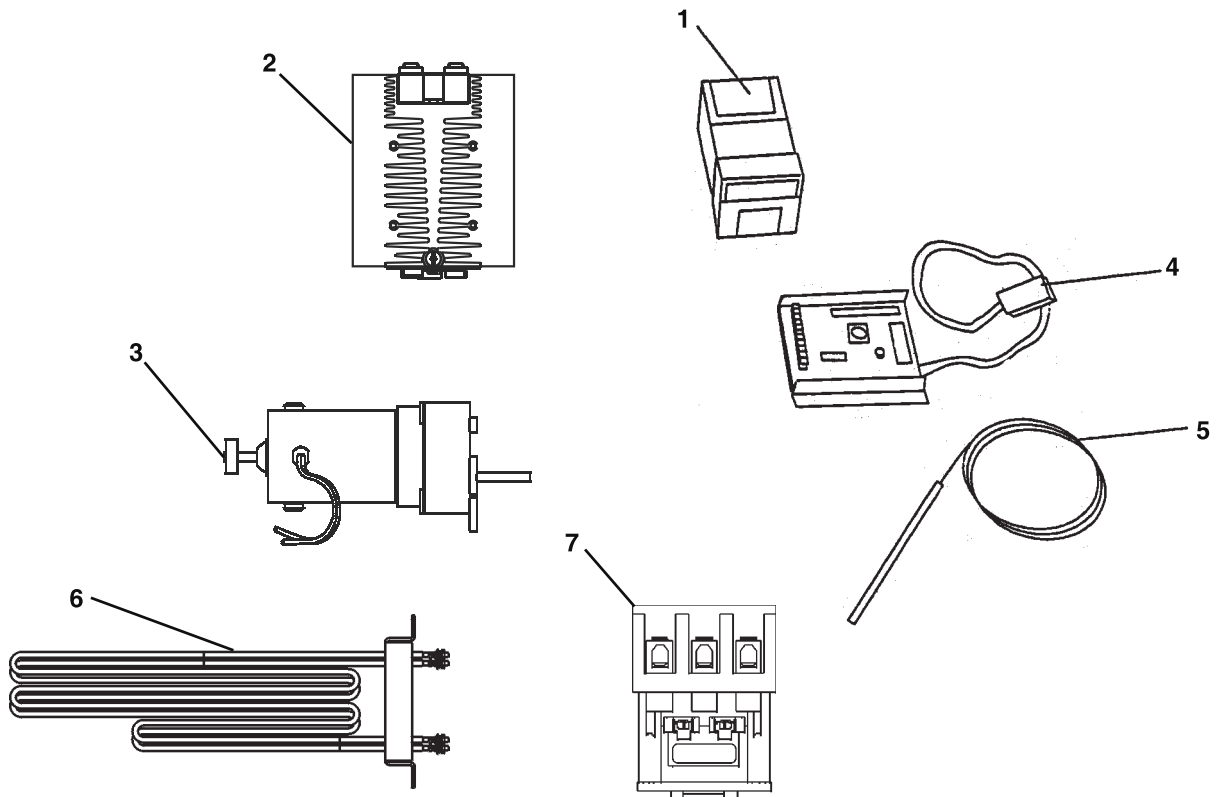

PS520E-SERIES PARTS MANUAL

Front View Of Oven

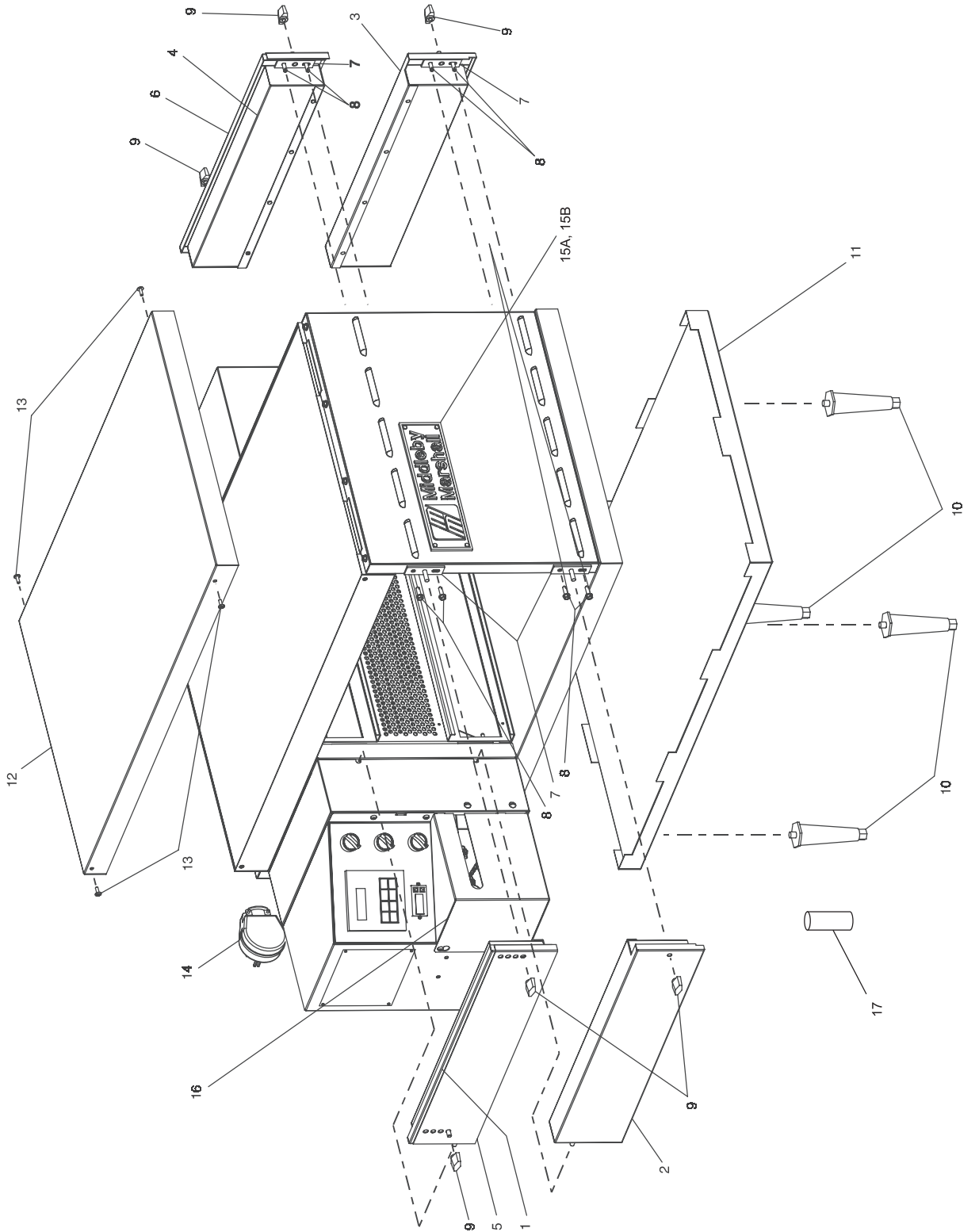

PS520E-SERIES PARTS MANUAL

Parts For Front View Of Oven

ITEM	QTY	PART NO.	DESCRIPTION
1	1	48382	Upper LH End Plug Assembly, includes item 5 eyebrow
2	1	48387	Lower LH End Plug Assembly
3	1	48408	Lower RH End Plug Assembly
4	1	48412	Upper RH End Plug Assembly, includes item 6 eyebrow
5	1	48378	Eyebrow, Upper LH End Plug Assembly
6	1	48410	Eyebrow, Upper RH End Plug Assembly
7	4	51398	End Plug Mounting Bracket Assembly .875"
8	8	21296-0005	Screw, Hex Head, WSHHD 12-14x3/4 SS BSD
9	6	36452	Nut, Wing-Plastic 1/4-20
10	4	3101908	Leg, 4" ADJ FT (NPS)
11	1	48395	Bottom Tray Assembly (includes insulation part #48392)
12	1	48396	Cover, Top
13	4	51387	Scr, MS, SLT THRD 8-32x1/2" 18-8
14	1	M10434	Cordset, 50 Amp 250V, 2P 3W 208/240V Models Only
15A	1	45739	Nameplate, Middleby Marshall
15B	1	59104	Nameplate, Noble Roman's
16	1	47861	Cover, Motor
17	4	M3828	Alignment Pin (Triple Stack)

View Of Right Hand Of Electrical Compartment

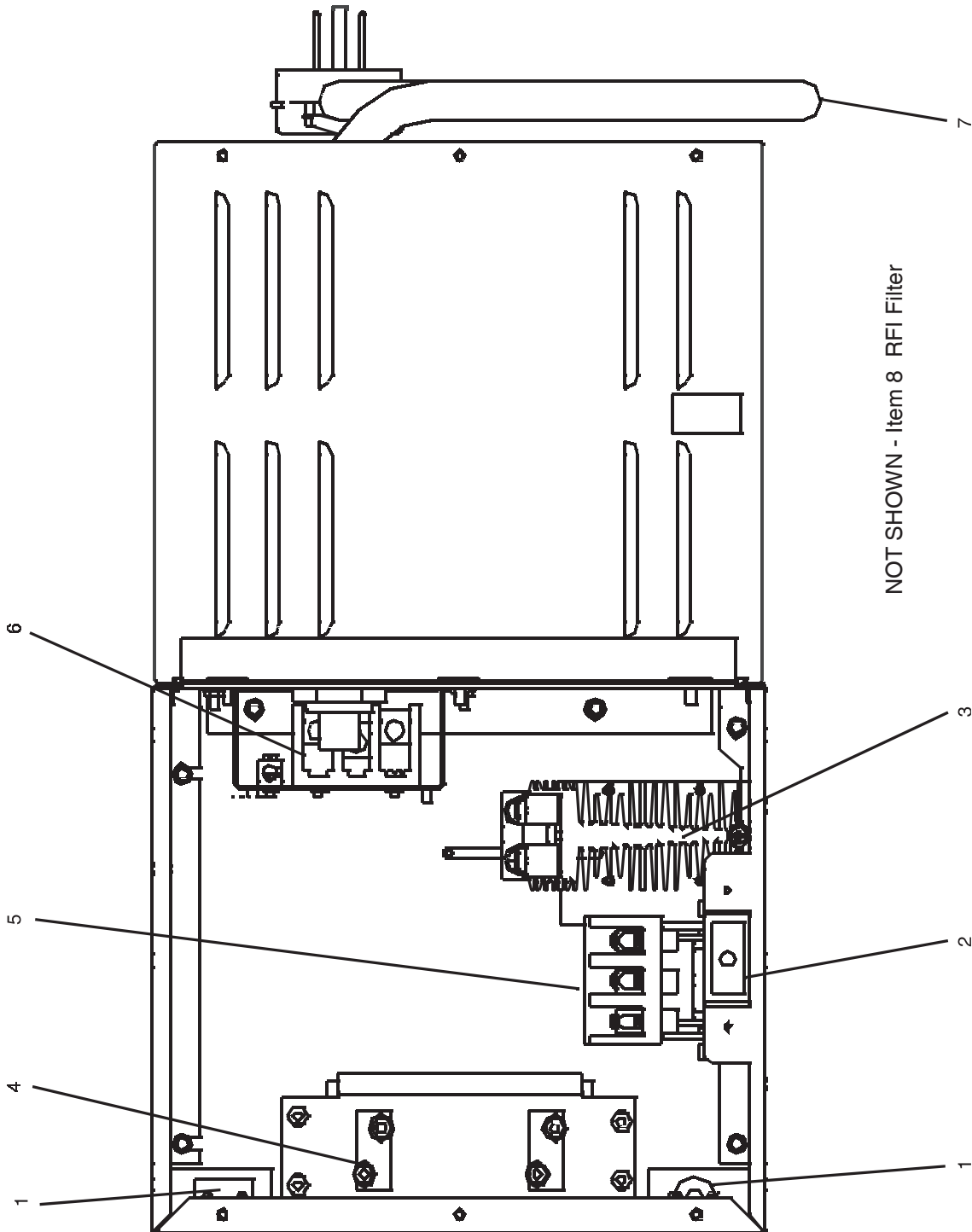

NOTE: Air switch was removed starting with serial #035870306 and after.

PS520E-SERIES PARTS MANUAL

Parts For Right Hand Electrical Compartment

ITEM	QTY	PART NO.	DESCRIPTION
1	1 or 2	33812-5	Thermocouple, Type "J" Shielded 2.5" x 120"
2	1	28021-0047	Switch, Interlock, 10A NO 2 Pole
3	1	51402	Relay, Heat Sink 100A
4	1	50715	Element, Heating, 208V
4	1	51017	Element, Heating, 240V
4	1	51958	Element, Heating, 380V
4	1	51961	Element, Heating, 480V
5	1	57408	Contact, 208/240V, 65A, 50/60 Hz
6	1	300-3946	Block-Power Dist 3-Pole
7	1	M10434	Cordset, 50 Amp, 250V, 2P 3W 208/240V Models Only
8	1	45244	RFI Filter - CE Only

PS520E-SERIES PARTS MANUAL

Rear View Of Blower Compartment

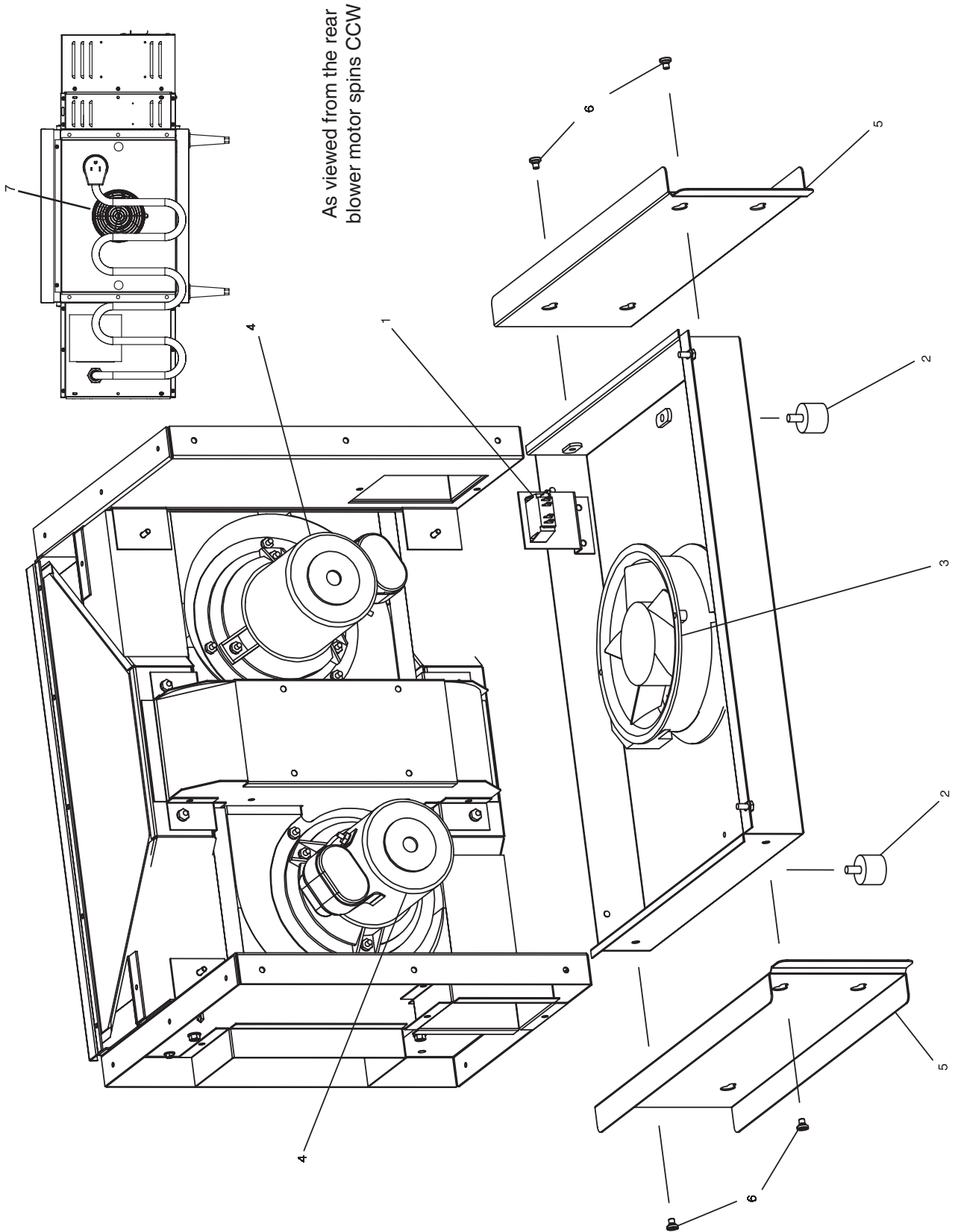

PS520E-SERIES PARTS MANUAL

Parts For Rear View Blower Compartment

ITEM	QTY	PART NO.	DESCRIPTION
1	1	28021-0061	Switch, Momentary-10A, NO 2 Pole
2	2	30927	Bumper, Window
3	1	51399	Fan, Cooling, 230V AC, 295 CFM
4	2	52244	Motor, Blower, CW, 208/230V 50/60 Hz With Blower Wheel
5	2	57258	Plate, Air Vent
6	4	7007413	SCR, Shoulder 10-32x3/4 18-8
7	1	31497	Guard-Cooling Fan

PS520E-SERIES PARTS MANUAL

View of Left Hand Electrical Compartment

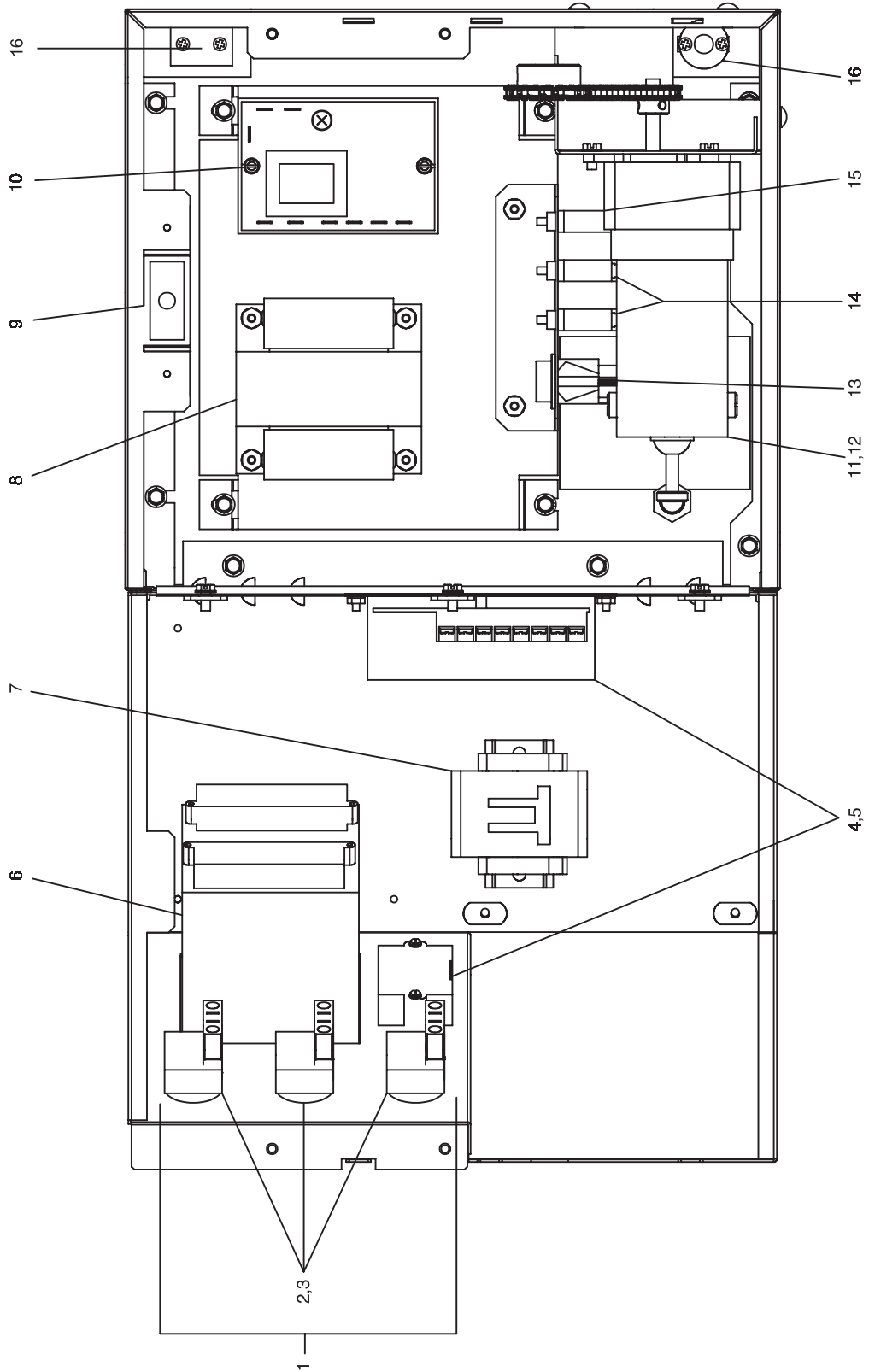

PS520E-SERIES PARTS MANUAL

Parts For Left Hand Electrical Compartment

ITEM	QTY	PART NO.	DESCRIPTION
1	3	46521	Kit Blower Switch (Contains (1) 44697, (1) 44696)
2	3	44697	Contact Block
3	3	44696	Selector Switch
4	1	58323	Conveyor Speed control w/Digital Speed Display
5	1	37503	Digital Speed Control (Display Only)
6	1	47321	Control, Combo 4-20MA (58504)
7	1	28041-0011	Contact, 208/240V-25A
8	1	31504	Transformer, 230V(P)/120(S), 200VA - Conveyor
9	1	28021-0047	Switch, Interlock, 10A
10	1	33983	Control, Electric, Hi-Limit, 240V
11	1	58390	Motor, Conveyor Drive With 2-Pole Magnet
11a	1	39002	Magnet 2-Pole
11b	1	310-0017	Adhesive
11c	1	58484	Kit, 2 Brushes & 2 Caps
12	1	38185	Sensor-Conveyor Pick-up
13	1	35145	Switch, Push-button, Molveno, 250V
14	2	45036	Breaker, Circuit 240V, 3A
15	1	48635	Breaker, Circuit 240V, 0.3A
16	1 or 2	33812-5	Thermocouple, Type "J", Shielded, 2.5"x 120"

View of Conveyor Parts

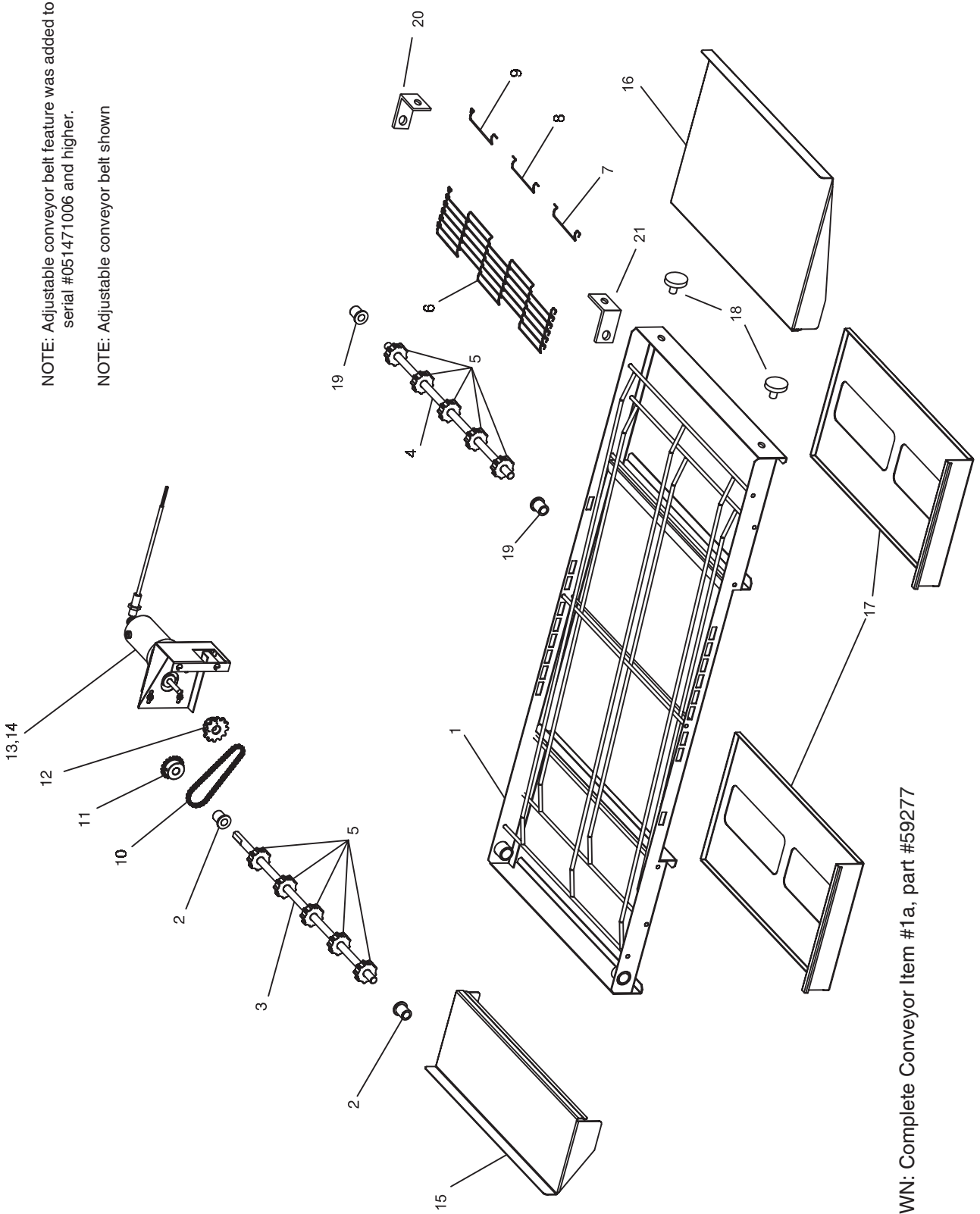

NOTE: Adjustable conveyor belt feature was added to serial #051471006 and higher.

NOTE: Adjustable conveyor belt shown

NOT SHOWN: Complete Conveyor Item #1a, part #59277

PS520E-SERIES PARTS MANUAL

Parts For Conveyor

ITEM	QTY	PART NO.	DESCRIPTION
1a	1	59277	Complete Conveyor Assembly - w/Adjustment Feature *
1b	1	59275	Frame Only - Conveyor - Weldment
1c	1	48471	Frame Conveyor (no adjustment)
2	2	M4817	Bearing, Rulon
3	1	M4815	Shaft, Drive
4a	1	59271	Shaft, Idler 18-1/4" *
4b	1	51408	Shaft, Idler 18-3/4"
5	10	M4818	Sprocket, Wire Belt
6a	1	59307	Belt, Wire, Stainless Steel, 18"x87-1/2" *
6b	1	M7471	Belt, Wire Stainless Steel
7	1	58391	Kit, Master Link Front, Middle, Rear
10	1	55567	Assy, Chain High Speed w/Master Link
10a	1	310-1212	Master Link Only
11	1	55217	Sprocket, chain #25-20T-1/2" Conveyor Shaft 25T
12	1	45349	Sprocket, 25B25 w/5/16" Bore - Drive Shaft
13	1	58390	Motor, Conveyor Drive w/2 Pole Magnet
13a	1	39002	Magnet 2-Pole
13b	1	310-0017	Adhesive
13c	1	300-2757	Conveyor Drive Motor Only
13d	1	58484	Kit, 2 Brushes & 2 Caps
14	1	38185	Sensor-Conveyor Pick-up
15A	1	59280	Extension, Conveyor - 6" *
15B	1	51297	Extension, Conveyor - 6"
16A	1	59272	Extension, Conveyor - 12" *
16B	1	51296	Extension, Conveyor - 12"
17A	2	51409	Pan, Crumb Vented - Shipped As Standard
17B	2	48469	Pan, Solid - Optional
18	2	59276	Screw Adjustment *
19	2	59264	Bushing, Rulon - Idler *
20	1	59267	Idler Guide - Back *
21	1	59270	Idler Guide - Front *

NOTE: ITEMS 1A, 4A, 6A, 15A, 16A, 18A-21A used on models with serial #051471006 and higher

PS520E-SERIES PARTS MANUAL

View of Cart Parts

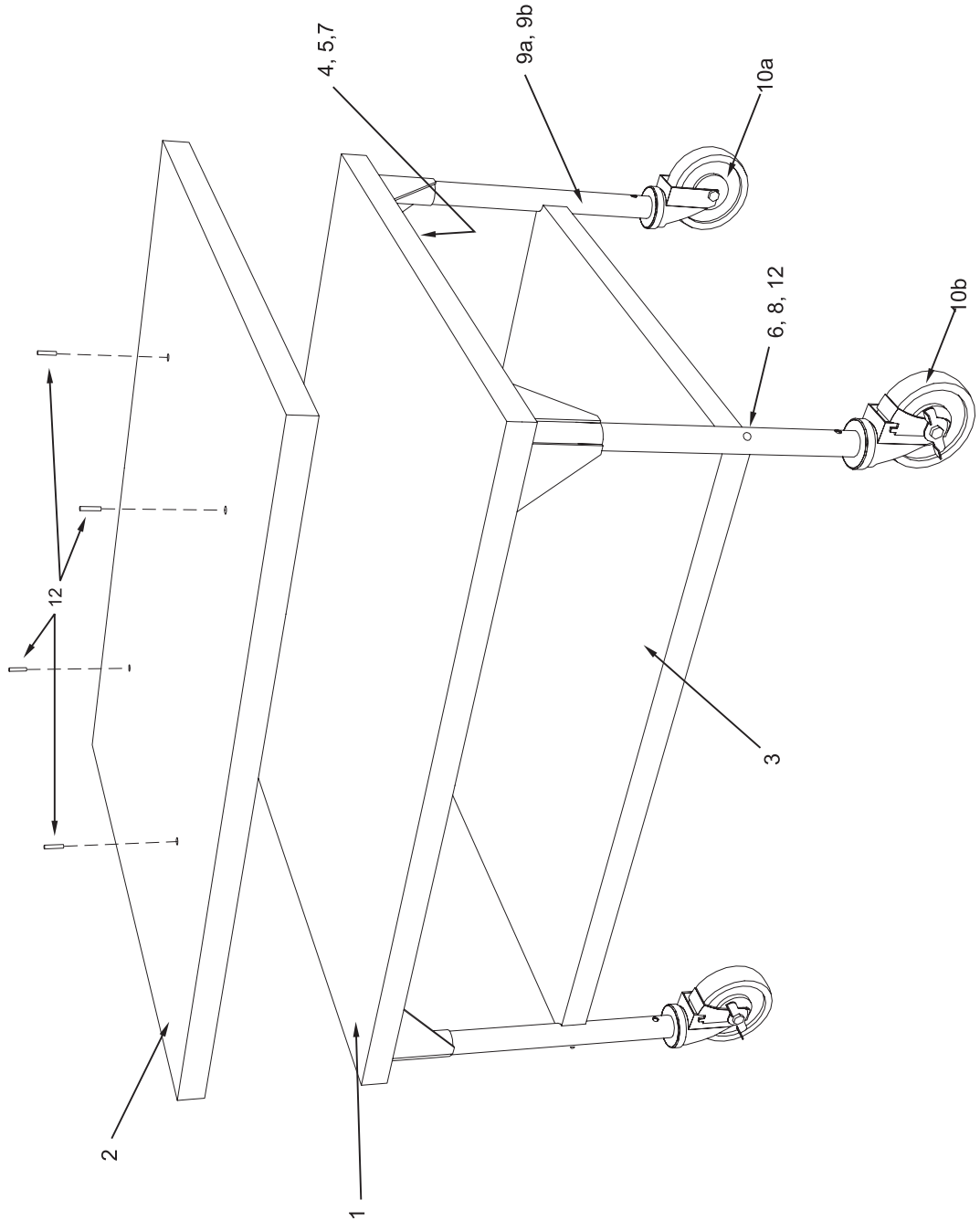

PS520E-SERIES PARTS MANUAL

Parts For Oven Cart

#52241 #54596
 Single/Double Triple
 QTY QTY

ITEM	QTY	PART NO.	DESCRIPTION
1	1	52237	Wldmt,Base Cart Panel PS520
2	1	52238	Panel, Cover Cart PS520
3	2	52240	Wldmt, Lower Shelf Cart Panel PS520
4	16	A3682	Washer, Lock 5/16"
5	16	B10012	Nut, Hex 5/16"-18 ZP
6	4	F706A8805	Washer, Flat Rivet Burr 1/4" NP
7	16	M0226	Washer, Flat 5/16"
8	4	M10435	Scr, MS PH PANHD 1/4"-20 x 2-14"
9a	4	M2585	Leg 18" Single and Double
9b	0	54657	Leg 5" - Triple Only
10a	2	15688	Caster w/o Brake
10b	2	15687	Caster w/Brake
11	4	M3828	Pin - Alignment
12	4	M7958	Nut, Nylon Insert 1/4-20

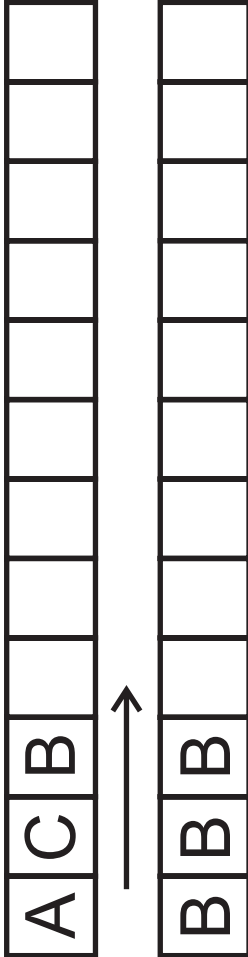

- A = 51357 PLATE,OTR L5GN W/7 HOLES
51027 PLATE,INR L5 GN COL/ALUZ
51986 WLDMT,MANF L5GN PRTL BFL
- B = 51356 PLATE,OTR L5GN W/2 ROWS
51027 PLATE,INR L5 GN COL/ALUZ
51986 WLDMT,MANF L5GN PRTL BFL
- C = 50682 PLATE,BLANK FULL
- D =
- E =
- F =
- G =

Notes

Rev	Date	Description	By
D	8/6/05	ADDED S1820 TO DESCRIPTION ECN 005287	AJ
C	7/6/05	DESC WAS CONFIG FINGER PS520E BRAND STD ECN 005240	AJ
B	3/22/04	RELEASE TO PRODUCTION ECN 002087	AJ

Description

CONFIG,FINGER PS520E/S1820 STD



Rev

D

P/N

51988

By

PS520E-SERIES SCHEMATICS

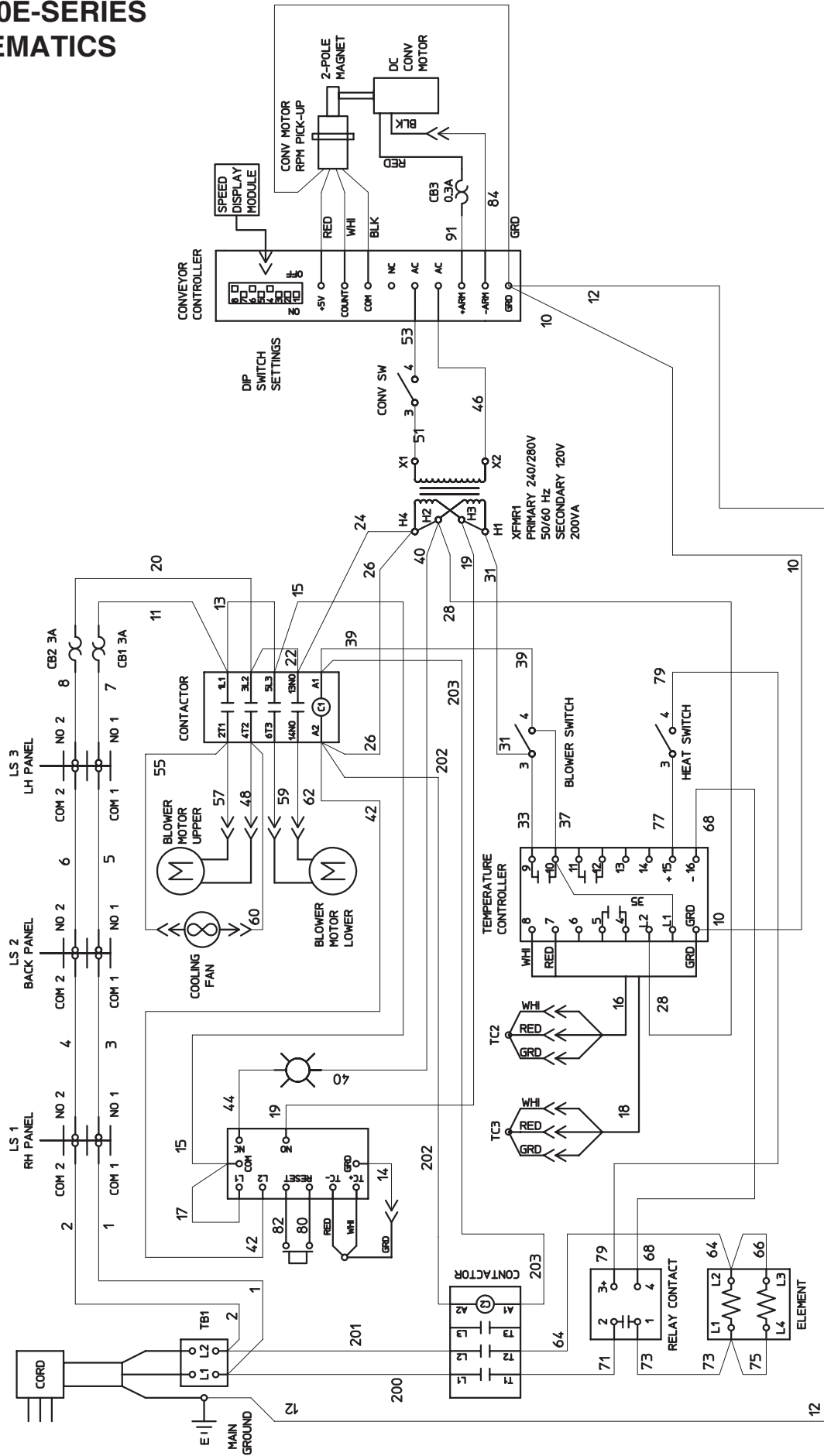

Drawing 48713 Rev J: Wiring Diagram, E208-240V 50/60/1

PS520E-SERIES SCHEMATICS

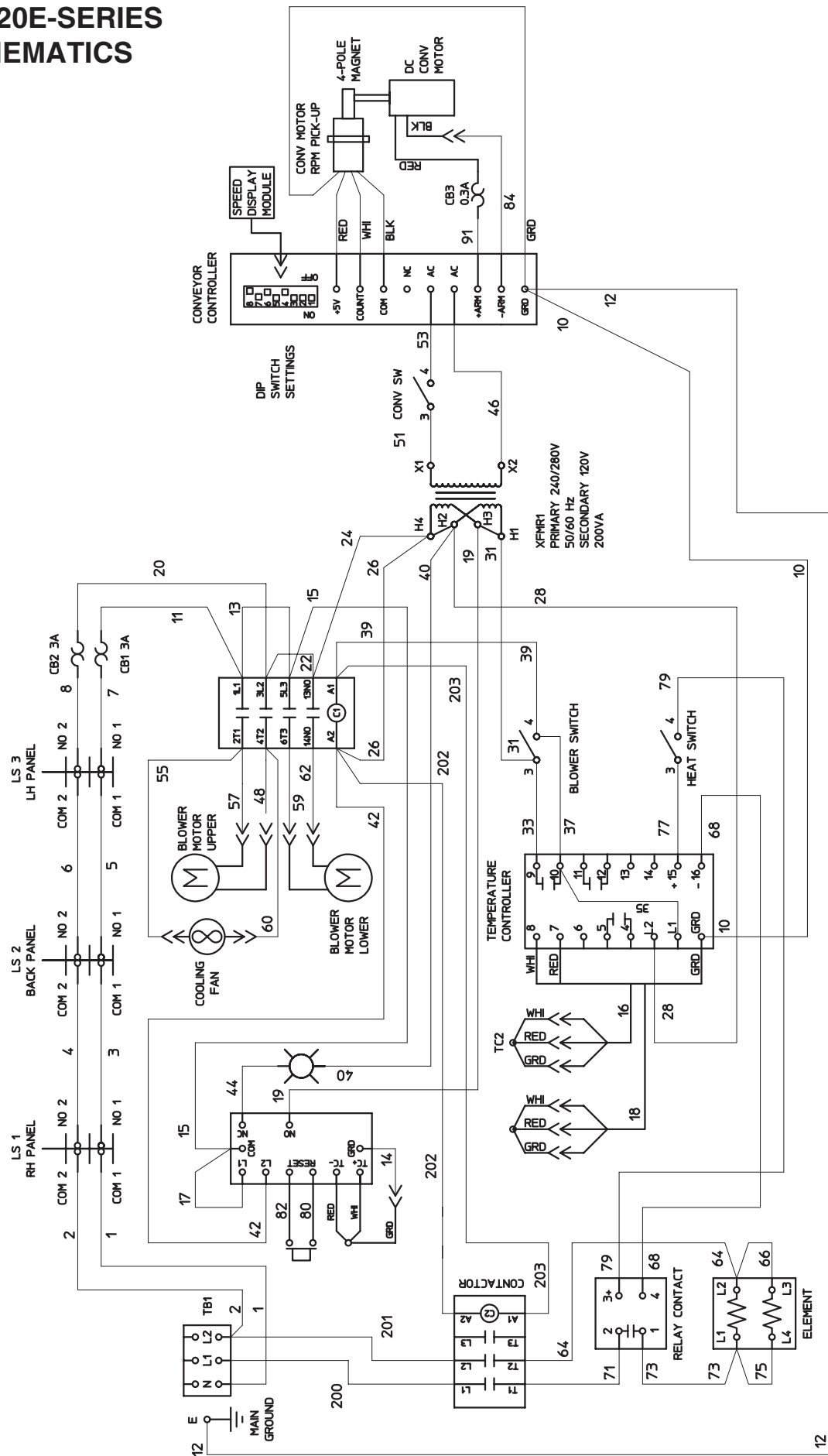

Drawing 52445 Rev J: Wiring Diagram, E380-480V 50/60/1

PS520E-SERIES SCHEMATICS

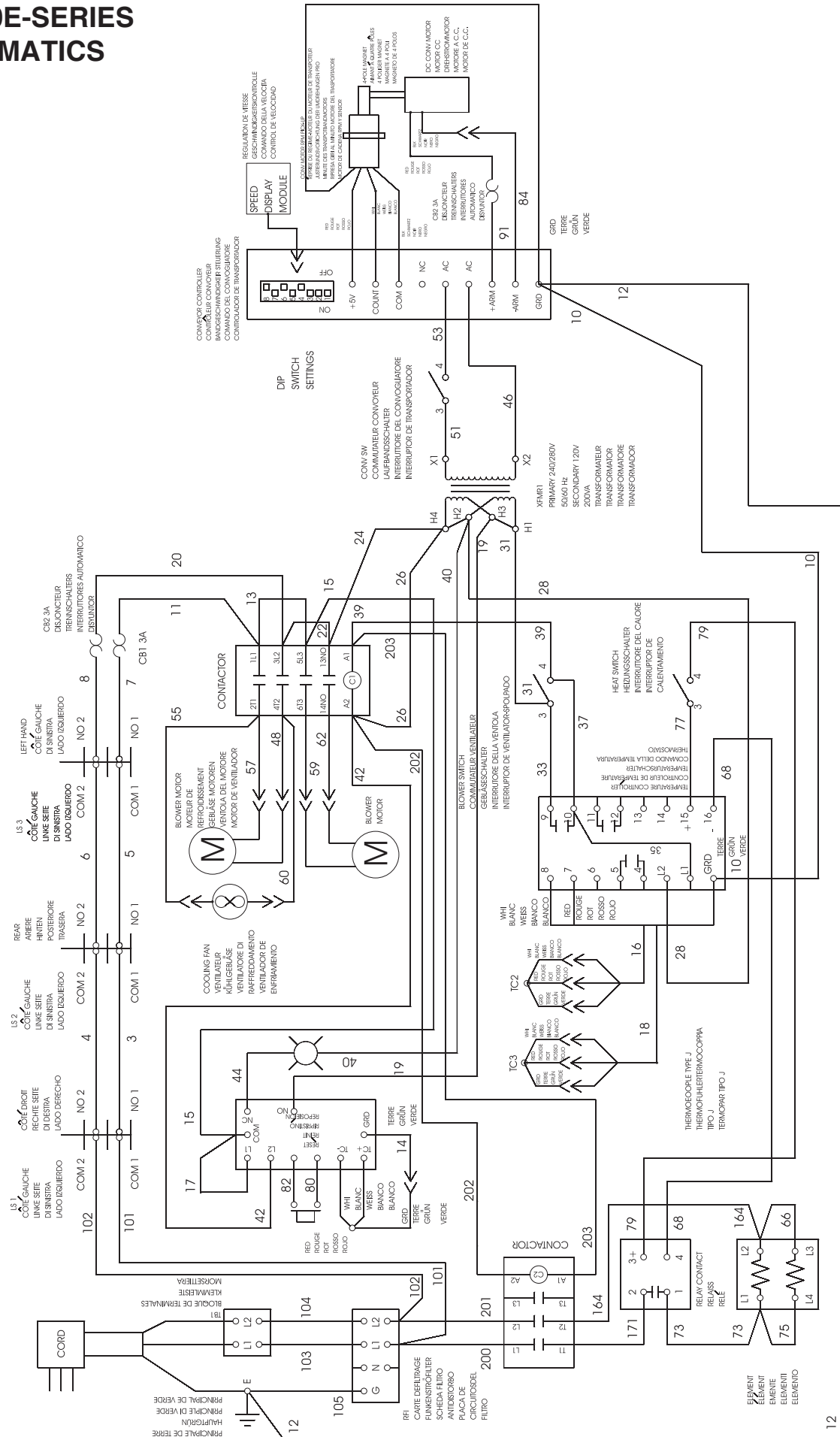

Drawing 52446 Rev K: Wiring Diagram, E230-240V CE, 1Ph

PS520E-SERIES SCHEMATICS

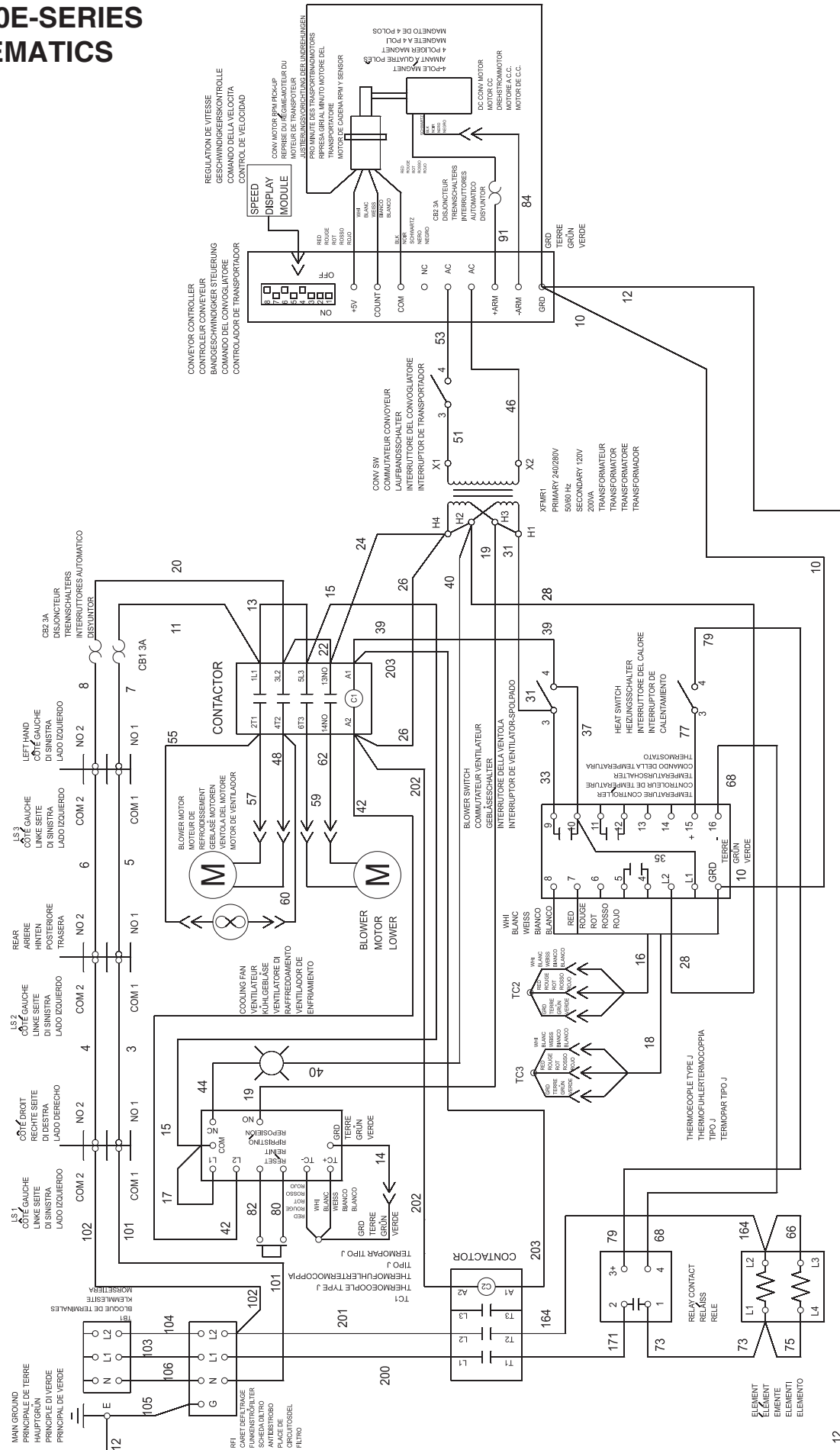

Drawing 54661 Rev J: Wiring Diagram, E380-400V CE, 1Ph

PS520E-SERIES SCHEMATICS

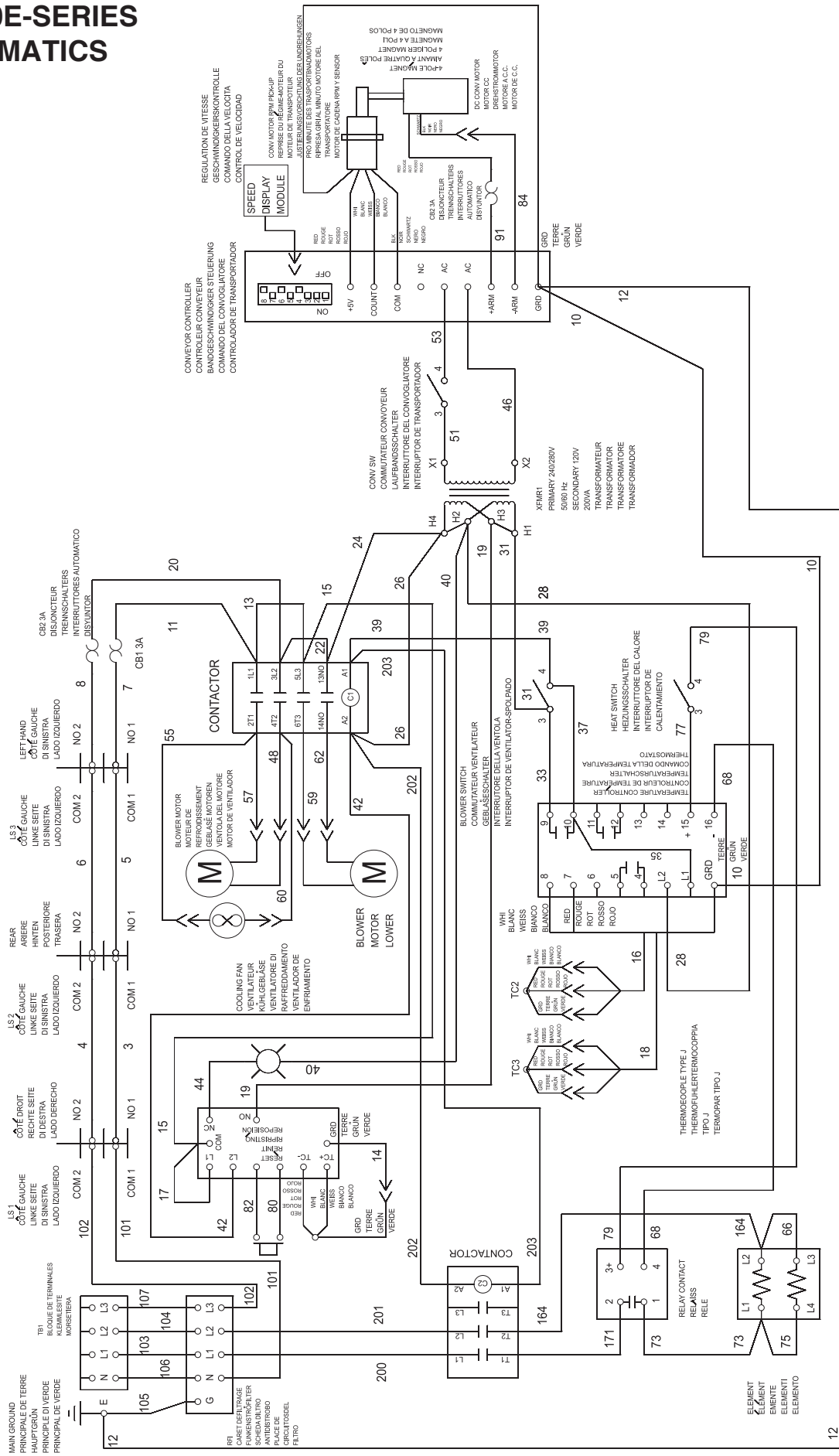

Drawing 58158 Rev F: Wiring Diagram, E380-400V CE, 3Ph

WARNING

Improper installation, adjustment, alteration, service or maintenance can cause property damage, injury or death. Read the installation, operating and maintenance instructions thoroughly before installing or servicing this equipment.

NOTICE

During the warranty period. ALL parts replacement and servicing should be performed by your Middleby Marshall Authorized Service Agent. Service that is performed by parties other than your Middleby Marshall Authorized Service Agent may void your warranty.

NOTICE

Using any parts other than genuine Middleby Marshall factory manufactured parts relieves the manufacturer of all warranty and liabilities.

NOTICE

Middleby Marshall reserves the right to change specifications at any time.

CFESA

Commercial Food Equipment Service Association

Middleby is proud to support the Commercial Food Equipment Service Association (CFESA). We recognize and applaud CFESA's ongoing efforts to improve the quality of technical service in the industry.

Middleby Cooking Systems Group • 1400 Toastmaster Drive • Elgin, IL 60120 • USA • (847) 741-3300 • FAX (847) 741-4406

www.middleby.com