

INSTRUCTION MANUAL



LEGEND GAS FIRED HEAVY DUTY RANGES

| | | |
|-----------|------------|------------------|
| 12 | M12 | 124 & 136 SERIES |
| 18 | M18 | V136 SERIES |
| 24 | M24 | |
| 36 SERIES | M36 SERIES | |



NOTICE

This manual is prepared for the use of Service Technicians and should not be used by those not properly qualified. This manual is not intended to be all encompassing. You should read, in its entirety, the repair procedure you wish to perform to determine if you have the necessary tools, instruments and skills required to perform the procedure.

RETAIN THIS MANUAL FOR FUTURE REFERENCE.

The MONTAGUE Company

1830 Stearman Ave. • P.O.Box 4954 • Hayward, CA 94540-4954

Tel: 510/785-8822

Fax: 510/786-9931

1-888-875-2722

WWW.MONTAGUECOMPANY.COM

IMPORTANT FOR YOUR SAFETY

THIS MANUAL HAS BEEN PREPARED FOR PERSONNEL QUALIFIED TO INSTALL GAS EQUIPMENT, WHO SHOULD PERFORM THE INITIAL FIELD START-UP AND ADJUSTMENTS OF THE EQUIPMENT COVERED BY THIS MANUAL.

POST IN A PROMINENT LOCATION THE INSTRUCTIONS TO BE FOLLOWED IN THE EVENT THE SMELL OF GAS IS DETECTED. THIS INFORMATION CAN BE OBTAINED FROM THE LOCAL GAS SUPPLIER.

WARNING

IN THE EVENT A GAS ODOR IS DETECTED, SHUT DOWN UNITS AT MAIN SHUTOFF VALVE AND CONTACT THE LOCAL GAS COMPANY OR GAS SUPPLIER FOR SERVICE.

FOR YOUR SAFETY

DO NOT STORE OR USE GASOLINE OR OTHER FLAMMABLE VAPORS OR LIQUIDS IN THE VICINITY OF THIS OR ANY OTHER APPLIANCE.

WARNING

IMPROPER INSTALLATION, ADJUSTMENT, ALTERATION, SERVICE OR MAINTENANCE CAN CAUSE PROPERTY DAMAGE, INJURY, OR DEATH. READ THE INSTALLATION, OPERATING, AND MAINTENANCE INSTRUCTIONS THOROUGHLY BEFORE OPERATING THIS EQUIPMENT.

SAVE THESE INSTRUCTIONS FOR FUTURE USE.

IMPORTANT

SHIPPING DAMAGE CLAIM PROCEDURE:

For your protection, please note that equipment in this shipment was carefully inspected and packed by skilled personnel before leaving the factory. The transportation company assumed full responsibility for safe delivery upon acceptance of this shipment.

IF SHIPMENT ARRIVES DAMAGED:

1. **VISIBLE LOSS OR DAMAGE**—Be certain this is noted on freight bill or express receipt, and signed by person making delivery.
2. **FILE CLAIM FOR DAMAGES IMMEDIATELY**—Regardless of the extent of damage.
3. **CONCEALED LOSS OR DAMAGE**—If damage is unnoticed until merchandise is unpacked, notify transportation company or carrier immediately, and file “concealed damage” claim with them. This should be done within fifteen (15) days of date that delivery was made to you. Be sure to retain container for inspection.

We cannot assume responsibility for damage incurred in transit. We will, however, be glad to furnish you with necessary documents to support your claim.

INTRODUCTION

GENERAL

The gas fired heavy duty ranges covered in this manual are manufactured for use with the type of gas indicated on the nameplate.

The Montague heavy duty ranges are produced with the best possible material and workmanship. Proper installation is essential for safe, efficient trouble-free operation.

MANIFOLD PRESSURE

Natural Gas: 6" W.C.
Propane Gas: 10" W.C.

PILOT ORIFICES

Natural Gas: .021
Propane Gas: .011

ORIFICES

Fixed for specified Gas type

Natural Gas:

Standard oven 136: 37
Convection Oven V136: 36

Propane Gas:

Standard Oven 136: 49
Convection Oven V136: 47

ELECTRICAL SPECIFICATIONS

| VOLTAGE | AMPS | PH | FREQ HZ | CONNECTIONS |
|---------|------|----|---------|---------------------------------------|
| 115 | 4.4 | 1 | 60 | 6-Feet (183 cm) 3-wire cord with plug |

INSTALLATION

THE INSTALLATION INSTRUCTIONS CONTAINED HEREIN ARE FOR THE USE OF QUALIFIED INSTALLATION AND SERVICE PERSONNEL ONLY. INSTALLATION OR SERVICE BY OTHER THAN QUALIFIED PERSONNEL MAY RESULT IN DAMAGE TO THE RANGE AND/ OR INJURY TO THE OPERATOR.

Qualified installation personnel are individuals, a firm, corporation or company which either in person or through a representative are engaged in, and are responsible for:

- A. The installation or replacement of gas piping or the connection, installation, repair or servicing of equipment, who is experienced in such work, familiar with all precautions required, and has complied with all requirements of state or local authorities having jurisdiction. Reference: National Fuel Gas Code Z223.1-1984, Section 1.4.
- B. The installation of electrical wiring from the electric meter, main control box or service outlet to the electric appliance. Qualified installation personnel must be experienced in such work, be familiar with all precautions required and have complied with all requirements of state or local authorities having jurisdiction. Reference: National Electrical Code, ANSI/ NFPA No. 70-1984

CAREFULLY READ AND FOLLOW THESE INSTRUCTIONS

THE RANGE(S) MUST BE INSTALLED IN ACCORDANCE WITH LOCAL CODES, OR IN THE ABSENCE OF LOCAL CODES, WITH THE NATIONAL FUEL GAS CODE, ANSI.1-1984, INCLUDING:

1. The appliance and its individual shutoff valve must be disconnected from the gas supply piping system during any pressure testing of that system at test pressures in excess of 1/2 psig (3.45 kPa).
2. The appliance must be isolated from the gas supply piping system by closing its individual manual shutoff valve during any pressure testing of the gas supply piping system at test pressures equal to or less than 1/2 psig (3.45 kPa).

THE UNIT WHEN INSTALLED MUST BE ELECTRICALLY GROUNDED IN ACCORDANCE WITH LOCAL CODES, OR IN ABSENCE OF LOCAL CODES, WITH THE NATIONAL ELECTRICAL CODE, ANSI / NFPA NO. 70-1984.

 **CAUTION**

Provisions must be made to assure adequate air supply to unit for proper burner operation.

CLEARANCES

Adequate clearance must be provided in the aisle, side and back to allow the doors to open wide enough to remove the racks and for service. Adequate clearance must be provided for air clearance.

A minimum of one inch (2.54 cm) clearance must be maintained behind the motor to provide air circulation and motor cooling.

The following is the minimum clearance from combustible material and noncombustible material.

| Location | Combustible Construction | Noncombustible Construction |
|------------|--------------------------|-----------------------------|
| Back Wall | 2" (5.88 cm) | **0" (0 cm) |
| Left Side | *6" (15.2 cm) | 0" (0 cm) |
| Right Side | *6" (15.2 cm) | 0" (0 cm) |

With 6" (15.2 cm) legs: Suitable for installation on combustible floors

Without legs: for use only on noncombustible floors.

Counter model: For installation on non combustible counter only.

*15" (38.1 cm) when installed with 30,000 BTU/HR burners.

**2" (5.88 cm) for convection ovens.

VENTILATING HOOD

The range(s) must be installed under a properly designed ventilating hood. The hood should extend at least 6" beyond all sides of the unit. The hood should be connected to an adequate mechanical exhaust system.

Information on construction and installation of ventilating hoods may be obtained from the "Standard for the Installation of Equipment for the Removal of Smoke and Grease Laden Vapors from Commercial Cooking Equipment", NFPA No. 96-1987, latest addenda, available from the National Fire Protection Association, Batterymarch Park, Quincy, Ma 02269.

It is also necessary that sufficient room air ingress be allowed to compensate for the amount of air removed by the ventilating system. Otherwise, a subnormal atmospheric pressure will occur and may interfere with burner performance or may extinguish the pilot flame. In case of unsatisfactory oven performance, check the exhaust fan. Make sure it is in the ON position.

ASSEMBLY

1. Uncrate range as near to final location as possible. Remove all shipping wire from burners and all packing material and accessories from oven interior.
2. Screw the adjustable feet of the legs in all the way. Then tightly screw the complete leg assembly into the mounting holes at each corner of the range. If the unit is intended for curb installation, no legs are provided. The curb must be noncombustible material.
3. Install door handle and secure with screws that are provided. Observe "UP" marking on handle for correct orientation.
4. If top castings are removed, identify castings so they are replaced in the same position and on same range as when received from the factory.

SETTING IN PLACE

Battery Arrangement

Floor mounted Ranges:

1. Place the first range in the exact position it will occupy in the battery.
2. Using a carpenter's level, level range from front to rear and side to side.

Adjust as follows:

| | |
|--|--|
| <p>FLOOR INSTALLATION ON LEGS</p> | <p>Adjust by turning Foot on adjustable leg.</p> |
| <p>CURB INSTALLATION ON LEGS</p> | <p>Place shim under the low side. It is very important to compensate for the variation in floors and curbs because unless ranges are level, they will not butt together tightly and it will be difficult to align the gas ranges with the gas supply manifold, which may affect proper operation, performance, and safety.</p> |

3. Remove the upper valve panel from range.
4. Move the next range into position.
5. Engage union nut on manifold with male fitting on next range and draw up union nut hand tight. Be sure appliances butt together, both front and rear. If manifolds do not align, then ranges are not level. In extreme cases, it may be necessary to loosen manifold bolts and adjust.
6. Continue leveling and connecting gas supply manifolds together until all appliances in battery are connected.
7. Tighten front manifold pipe union gas tightly. Use back up wrench to prevent manifold from rotating.

 **CAUTION**

Failure to do this may result in damage to pilot and gas valves.

Modular Ranges:

Assemble modular base and set in place. Adjust feet as explained above. Connect ranges as shown for battery arrangement.

Fry Top Ranges

Fry Top Plate Adjustment: Leveling bolts are at the rear of the range under the fry top plate.

Adjust the leveling bolts so that the plate is pitched to the front to provide for grease runoff as shown in **Figure 2**.

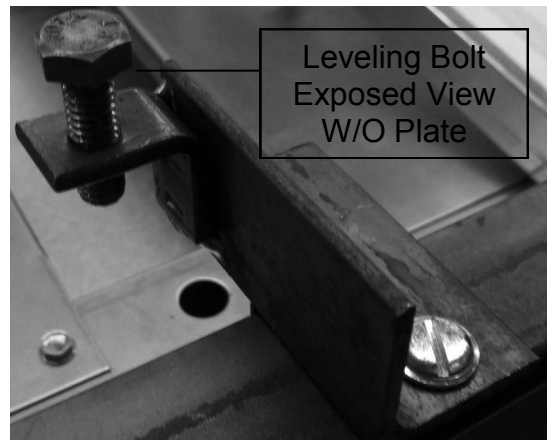

Figure 2. Pitch of Fry Top Plate

High Shelves and Salamander Broilers

Lift high shelf or broiler above the range and slide legs into position as shown in Figure 3.

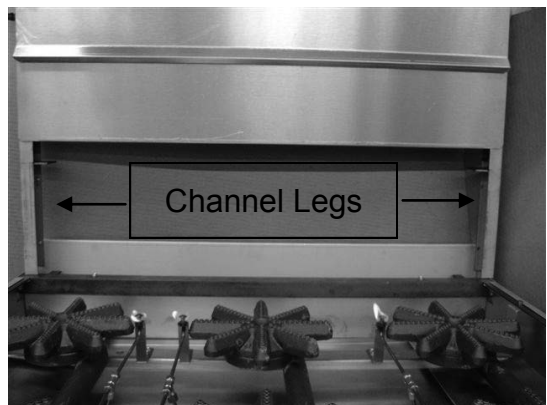

Figure3. Mounting High Shelf

GAS APPLIANCE REGULATOR

At the time of installation, a gas appliance pressure regulator suitable for the battery application and adjusted for the manifold pressure specified on the range nameplate must be installed.

NATURAL GAS

This gas pressure regulator should be adjusted for 6.0" W.C. manifold pressure. The maximum rated inlet pressure to the regulator is 1/2 psig (3.45 kPa).

PROPANE GAS

This gas pressure regulator should be adjusted for 10.0" W.C. manifold pressure. The maximum rated inlet pressure to the regulator is 1/2 psig (3.45 kPa).

The oven is equipped with fixed orifices for use with a manifold pressure of 6.0" W.C. for natural gas and 10.0" W.C. for propane gas.

Mount the gas pressure regulator as near to the range as possible but located outside the heat zone to prevent damaging it. Mount horizontally with the arrows pointing toward the manifold input.

The gas pressure regulator furnished by the manufacturer complies with the following:

1. Have a maximum regulation capacity for the total connected load.
2. Must be listed by a nationally recognized testing agency.
3. Must have a pressure adjustment range to allow adjustment.

Note: Unless the manifold pressure on all connected appliances is the same, a separate pressure regulator must be supplied for each appliance with a different manifold pressure.

EXTERNAL GAS SHUTOFF VALVE

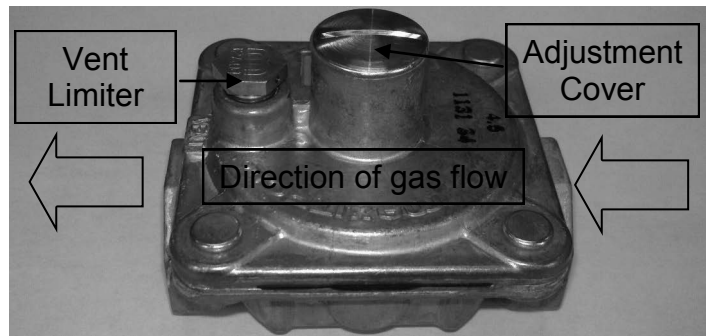

Figure 4. Gas Pressure Regulator

Codes require that a gas shutoff valve be installed in the gas line before the range.

GAS CONNECTION

NOTE: Pipe joint compound or thread sealant that is used should be resistant to action of liquefied petroleum gases.

Before connecting the range(s) to the gas supply line, be sure that all new piping has been cleaned and purged to prevent any foreign matter from being carried into the controls by the gas. In some cases, filters or drops are recommended. A separate gas shut off valve must be installed upstream from the gas pressure regulator adjacent to the oven and located in an accessible area.

It is important that adequately sized piping be run directly to the point of connection at the range with as few elbows and tees as possible. Consult local gas company for proper piping size and gas pressure. Each range has a 1 1/4" NPT manifold input located at the front of the range for battery connection, Figure 5. A 1 1/4" union is located at either end of the manifold.

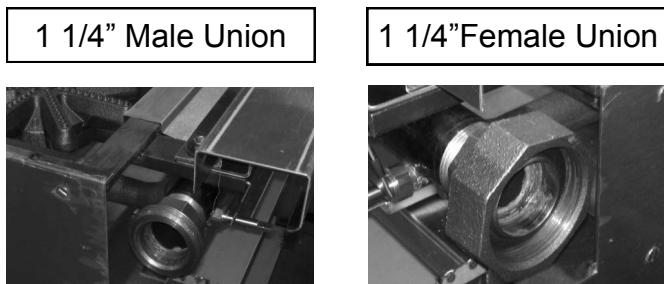

Figure 5. Gas Supply Connections

 **WARNING**

CAP ALL UNUSED OPEN ENDS OF THE GAS SUPPLY MANIFOLD.

 **WARNING**

DO NOT USE A DOMESTIC TYPE GAS FLEXIBLE CONNECTOR.

NOTE: If flexible or semi-flexible connectors are used, use only AGA listed flexible connectors with an I.D. equal to 1" pipe.

Install the gas pressure regulator with gas flowing as indicated by the arrow on the regulator. The arrow must be pointing toward the unit. Using pipe compound or thread sealant, carefully thread regulator to pipe so that there is no cross threading, etc., which could cause leakage.

1. Apply wrench only to the flat areas around the pipe tapping at the end being threaded to the pipe to avoid possible regulator body damage, which could result in leakage.
2. Connect the gas supply line from the service gas shut off valve to the inlet side of the gas pressure regulator using 1" pipe. Avoid kinks or sharp bends that could restrict gas flow.

 **WARNING**

TEST ALL PIPE JOINTS FOR LEAKS BEFORE OPERATING RANGE. THIS INCLUDES ALL GAS CONNECTIONS THAT MAY HAVE LOOSENED DURING SHIPMENT. USE A RICH SOAP SOLUTION (OR OTHER ACCEPTED LEAK TESTER) AROUND ALL PIPE CONNECTIONS AND ALL OTHER JOINTS. DO NOT USE AN OPEN FLAME. ABSOLUTELY NO LEAKAGE SHOULD OCCUR, OTHERWISE, THERE IS A DANGER OF FIRE OR EXPLOSION DEPENDING UPON CONDITIONS. DO NOT USE UNIT IF LEAKAGE IS DETECTED.

3. Before attempting to operate the oven, turn gas shut off valve on and immediately check for gas leaks. After piping has been checked for leaks, all piping receiving gas should be fully purged to remove air.

ELECTRICAL CONNECTION

Unless otherwise specified, the range is equipped with a 6 ft. flexible supply cord for 115 VAC, 60 or 50 Hertz, single phase units. The wiring diagram is located on the back of the range.

NOTE: THIS APPLIANCE WHEN INSTALLED, MUST BE ELECTRICALLY GROUNDED IN ACCORDANCE WITH LOCAL CODES, OR IN THE ABSENCE OF LOCAL CODES, WITH THE NATIONAL ELECTRICAL CODE, ANSI/NFPA NO. 70-1984.

I. 115 VAC - 60 Hz - SINGLE PHASE

Ranges with this electrical rating are factory supplied with a three wire cord and three prong plug which fits any standard three prong grounded receptacle. a separate 15 amp. supply is needed for each oven.



ELECTRICAL GROUNDING INSTRUCTIONS

THIS APPLIANCE IS EQUIPPED WITH A THREE PRONG (GROUNDING) PLUG FOR YOUR PROTECTION AGAINST SHOCK HAZARD AND SHOULD BE PLUGGED DIRECTLY INTO A PROPERLY GROUNDED THREE PRONG RECEPTACLE. DO NOT CUT OR REMOVE THE GROUNDING PRONG FROM THIS PLUG.

II. 208-240 VAC - 60 Hz - SINGLE PHASE (2 WIRE)

Ranges with this electrical rating are factory equipped with a terminal block. To connect supply wires, remove cover from connection box at right rear of range. Route supply wires and ground wire through hole with strain relief fitting at top of connection box. Attach supply wires to proper terminal of terminal block. Attach ground wire to ground lug inside connection box. See wiring diagram for proper connection.

III. 220 VAC - 50 Hz - SINGLE PHASE (2 WIRE)

Follow steps outlined in (II.) Refer to wiring diagram for proper connection.

PILOT ADJUSTMENT - TOP BURNERS

OPEN TOP: The front and rear pilots are controlled by one valve. To adjust pilot, turn adjusting screw counter-clockwise to increase or clockwise to decrease pilot flame. Adjust flame to a point where only a trace of yellow tip remains.

HOT TOP & FRY TOP: Each pilot is controlled by a pilot valve. Turn adjusting screw until pilot flame is 1/2" high.

FRY TOP & OVEN THERMOSTATS

The bypass (minimum burner flame) must be checked when performing checkout of range prior to placing equipment in service. The bypass must be set carefully and accurately. Refer to service section of this manual for proper procedure.

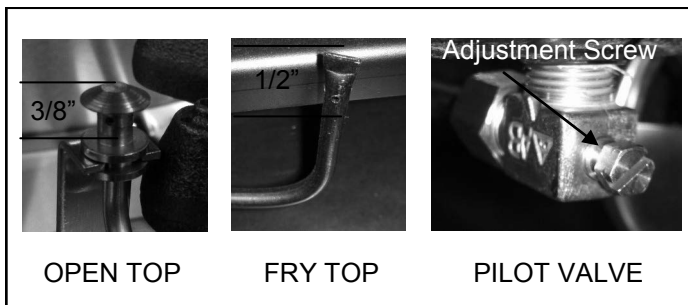

Figure 6. Pilot Flame

BURNER ADJUSTMENT

The efficiency of the range depends on a delicate balance between the supply of air and the volume of gas so that complete combustion is achieved. Whenever this balance is disturbed, poor operating characteristics occur.

The air supply is controlled by an air shutter on the front of the burner. The air shutter opening should be increased until the flame on the burner begins to "lift". The air shutter should then be closed slightly and locked in place. A yellow streaming flame indicates insufficient air. This condition can be corrected by increasing the air shutter opening.

OPERATION

GENERAL

This appliance has been classified as commercial cooking equipment and must be operated by qualified and/or professional personnel.

WARNING

THE OVEN AND ITS PARTS ARE HOT. USE CARE WHEN OPERATING, CLEANING OR SERVICING THE UNIT.

CAUTION

Do not obstruct the flow of combustion and ventilation air to the oven. Keep appliance area free and clear of combustibles.

GAS CONTROLS

WARNING

IN THE EVENT A GAS ODOR IS DETECTED, SHUT DOWN UNITS AT MAIN SHUT OFF VALVE AND CONTACT THE LOCAL GAS COMPANY OR GAS SUPPLIER FOR SERVICE.

TOP BURNERS (OPEN), HOT TOP, & MANUAL FRY TOP

1. Check that pilots are lit
2. Rotate valve handles counter-clockwise to full ON position and burner will ignite automatically.
3. Adjust flame height as desired.
4. To shut down, rotate valve handle clockwise to OFF position.

FRY TOP THERMOSTATIC CONTROLLED

1. Check that pilots are lit.
2. Push thermostat dial inward and rotate dial counter-clockwise to desired set temperature and burner will ignite automatically.
3. To shut down, rotate thermostat dial clockwise to OFF position.

OVEN (136 SERIES)

Lighting

Turn burner valve to OFF position and wait five (5) minutes.

1. Remove burner compartment cover and open pilot access door.
2. Press and hold red button (**Pilot Safety Valve**) in and apply lighted match or lighter to pilot burner.

3. After pilot burner ignites, continue to hold red button depressed for 30 to 45 seconds or until pilot remains burning when button is released. If pilot goes out, repeat process.
4. Close pilot access door and replace burner compartment cover.
5. Rotate thermostat dial counter-clockwise to desired temperature setting and turn Main Burner Valve to the ON position.
5. If the pilot burner is unable to be lit with the Piezo Igniter, apply a lighted match to the pilot burner.
6. Close pilot access door and replace burner access panel.
7. Push thermostat dial inward and rotate dial counter-clockwise to desired temperature setting.

NOTE: In the event of pilot failure, turn burner valve clockwise to OFF position and wait five (5) minutes for unburned gas to escape from range.

NOTE: In the event of pilot failure, rotate thermostat dial clockwise to OFF position and wait five (5) minutes for unburned gas to escape from range.

OVEN OPERATION

1. Turn thermostat dial to desired temperature and open Main Burner Valve to the ON position.
2. Limit preheat time to 20-30 minutes.
3. Place food in oven making sure pans do not touch other pans or oven walls.
4. Do not cover racks with aluminum foil.
5. Load and unload quickly and avoid frequent opening of door.
6. Turn off when not in use.

OVEN OPERATION

1. Turn thermostat dial to desired temperature.
2. Limit preheat time to 10-20 minutes.
3. Place food in oven making sure pans do not touch other pans or oven walls.
4. Do not cover racks with aluminum foil.
5. Load and unload quickly and avoid frequent opening of doors.
6. Turn off when not in use.

SHUT DOWN

Turn burner valve clockwise to OFF position.

SHUT DOWN

Rotate thermostat dial clockwise to OFF position.

OVEN (124 SERIES)

Lighting

Turn thermostat knob to Off position and wait five (5) minutes.

1. Remove burner compartment cover and open pilot access door.
2. Locate Piezo Igniter in front of the pilot access door.
3. Press and hold red button in (Pilot Safety Valve) and repeatedly depress the button on the Piezo Igniter until the pilot burner ignites.
4. After pilot burner ignites, continue to hold red button depressed for 30-45 seconds or until pilot remains burning when button is released. If pilot goes out, repeat process.

V136 SERIES OVENS

OPERATING CONTROLS

Using A Convection Oven

The convection oven offers many features and advantages not available in a conventional oven. Operation is not difficult to understand or control.

The Montague convection oven is a “Muffled” style oven that keeps the by-product of combustion separated from the air circulated in the oven. The heat surrounding the oven cavity is transferred from the outer surface into the interior of the oven. A fan continuously circulates the heated air around the product. The moving air strips away the insulating layer of moisture on the products allowing heat to penetrate faster and for more efficient baking and roasting.

Due to the differences in cooking methods, procedures and techniques for convection oven cooking may require modification for successful results. A general rule to remember is that standard recipe cooking times will be shorter and temperatures should be 25-75F degrees lower in a convection oven.

NOTE: For convection oven cooking, reduce temperature 25-75F degrees from those given in standard conventional oven recipes.

WARNING

***THE OVEN AND ITS PARTS ARE HOT.
USE CARE WHEN OPERATING,
CLEANING OR SERVICING THE UNIT.***

CAUTION

Do not obstruct the flow of combustion or ventilation air from the oven. Keep appliance area free and clear of combustion.

The following controls are used for operation of the oven.

| REF # | CONTROL | FUNCTION |
|-------|--------------------|--|
| 1 | FAN SWITCH | Three position rocker switch: FAN/OFF/COOL . FAN (top position) Circulates air in oven. OFF (center position) Turns fan off COOL DOWN (bottom position) Provides continuous fan operation for cooling oven at the end of the work period, operates with doors opened or closed. Cools with doors open. |
| 2 | THERMOSTAT | Sets temperature between 200-500F (93-260C) |
| 3 | PILOT SAFETY VALVE | Ignites Pilot & Shuts down gas supply to Pilot & Burner in the event of a pilot outage. |
| 4 | PIEZO IGNITER | Provides spark to ignite Pilot |

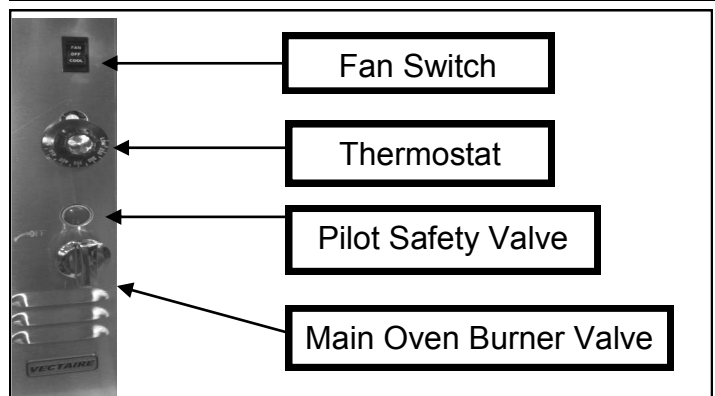

Figure 7. Operating Controls

SUGGESTIONS

Lighting

1. Turn oven burner valve clockwise to “**OFF**” position.
2. Open main shutoff valve in the rear of the unit to supply gas to the equipment.
3. Remove burner compartment access panel below the oven doors.
4. Press and hold the red button of the Pilot Safety Valve while applying a flame to the pilot burner. If unit has a piezo ignitor option, repeatedly depress the button on the piezo ignitor until the pilot burner ignites. Hold pilot safety button depressed for 30-45 seconds or until pilot remains lit when button is released.
5. Replace burner compartment access panel.
6. Set thermostat to desired temperature.
7. Turn oven burner valve counter-clockwise to “**ON**” position.
8. Turn on fan, which should be on at all times during cooking operation.

Shut Down

1. Stand By
 - a. Turn oven burner valve to OFF position.
 - b. Turn FAN control to OFF position.
2. Complete
 - a. Turn all gas valves to OFF position.
 - b. Turn Fan Control to OFF position.
 - c. Turn electrical service off or disconnect electrical supply cord from wall outlet.

Relighting

1. Turn gas burner valve to Off position.
2. Wait five (5) minutes then follow **LIGHTING** instructions.

- It is not necessary to turn on all equipment first thing in the morning. Turn on only the equipment needed to begin the day and leave equipment off until it is needed.
- The open top burner does not need to preheat. Use full flame to start foods cooking quickly. Reduce flame to simmer foods. Regulate the burners so that flame tips just touch the bottom of the utensil. Use lids on pots to keep heat in. Turn burner off when not in use.
- Limit preheat time to 10-15 minutes on hot top ranges and use full flame. Use flat bottom pans for efficient use of heating. During idling period, use low flame or turn one or more burners off. Heat only section of hot top required.
- Preheat fry top 10-15 minutes prior to use. Usually, a medium or low flame is adequate for light frying. If fry top has a thermostat, use it to avoid wasting gas and for best results. During slack periods, turn the burner down.

MAINTENANCE

CAUTION

DISCONNECT POWER BEFORE CLEANING OR SERVICING. EACH OVEN SECTION HAS A SEPARATE ELECTRICAL SUPPLY CONNECTION.

CARE & CLEANING

The complete range should be given a periodic general cleaning. Lint and grease suspended in the air tend to collect in passages. Therefore, all flueways, air passages and openings, burner ports, primary air openings, etc. should be periodically cleaned to prevent clogging.

EXTERIOR

PAINTED SURFACES: Allow equipment to cool after use and wash with a mild detergent or soap solution. Dry thoroughly with a dry cloth.

STAINLESS STEEL SURFACES: To remove dirt, grease, or product residue, from stainless steel, use ordinary soap and water (with or without detergent) applied with a sponge or cloth. Dry thoroughly with a clean cloth.

To remove grease and food splatter, or condensed vapors, that have baked on the equipment apply cleanser to a damp cloth or sponge and rub cleanser on the metal in the direction of the polishing lines on the metal. Rubbing cleanser as gently as possible in the direction of the polished lines will not mar the finish of the stainless steel. **NEVER RUB WITH A CIRCULAR MOTION.** Soil and burnt deposits which do not respond to the above procedure can usually be removed by rubbing the surface with SCOTCH-BRITE scouring pads or STAINLESS scouring pads. DO NOT USE ORDINARY STEEL WOOL as any particles left on the surface will rust and further spoil the appearance of the finish.

NEVER USE A WIRE BRUSH, STEEL SCOURING PADS (EXCEPT STAINLESS), SCRAPER, FILE, OR OTHER STEEL TOOLS. Surfaces which are marred collect dirt more rapidly and become more difficult to clean. Marring also increase the possibility of corrosive action.

TO REMOVE HEAT TINT: Darkened areas sometimes appear on stainless steel surfaces where the area has been subjected to excessive heat. These darkened areas are caused by thickening of the protective surface of the stainless steel and are not harmful. Heat tint can normally be removed by the foregoing, but tint which does not respond to this procedure calls for a vigorous scouring in the direction of the polish lines, using Scotch-Brite scouring pads or a STAINLESS scouring pad in combination with a powdered cleanser. Heat tint action may be lessened by not applying or by reducing heat to equipment during slack periods.

OVEN INTERIOR

STANDARD FINISH (Porcelain Enamel): Frequent cleaning is required. Spillovers should be cleaned as soon as possible to prevent carbonizing and a burnt on condition. Wait until oven is cool for complete cleaning. Usually a soap or detergent solution is strong enough to remove any grease residue. A mild abrasive nylon cleaning pad may be used for stubborn spillover or stains. Non-caustic commercial oven cleaners may be used, however, do not allow cleaners to come in contact with the temperature probe. Wipe off all oven cleaner residue.

OPEN TOP SECTION

DAILY: Wipe top with burlap or other grease absorbing material to remove spillovers, grease, etc., before they burn in.

WEEKLY: Open Top Section should be washed in a solution of washing soda and water (after they are entirely cooled) Remove and wash drip pan under burners. Brush burner head weekly with a stiff wire brush and clean clogged ports with stiff wire or ice pick. Excessive grease build up may be removed from burners by soaking in a solution of washing soda. Dry burners by inverting on oven rack in a low temperature oven.

HOT TOP SECTION

DAILY: Wipe top with heavy burlap or steel wool, rub briskly until clean. Lift rings and plates to clean all flanges and under lid. **NEVER POUR WATER ON A HOT TOP SECTION.**

FRY TOP SECTION

DAILY: Use flat edge of spatula or metal scraper to keep surface free of encrusted material during use, wipe frequently with heavy absorbent cloth. After griddle is cooled, polish with soft griddle stone or a good grade grill pad. **DO NOT SCRATCH.** The griddle may be washed with warm water and a cleanser. Water will not crack this griddle plate.

NOTE: To oil the griddle, use a hydrogenated shortening. Never use salad oils, margarine, or butter, as these shortenings cannot withstand temperatures exceeding 300 degrees F.

ELECTRIC MOTOR

The electric motor has been specially manufactured for this blower application and should give years of trouble-free service under normal conditions.

The motor is supplied with permanently lubricated sealed bearings which require no additional lubrication. A high temperature grease has been used to increase bearing life and should only be replaced by an authorized service agent.

The motor is of an open drip-proof type construction, and as such, care should be taken to see that the ventilation openings remain clear.

The motor is equipped with built-in automatic thermal overload protection to prevent damage from overheating.

If problems do develop with the motor, contact your nearest authorized service agent.

NOTE: The motor should be periodically cleaned of grease debris and lint. Keep vent clean for peak performance.



CARE SHOULD BE USED WHEN WASHING DOWN EQUIPMENT TO KEEP WATER AND CLEANING SOLUTIONS OUT OF THE MOTOR OR DAMAGE WILL OCCUR.

MAINTENANCE SCHEDULE

| COMPONENTS | JAN | FEB | MAR | APRIL | MAY | JUNE | JULY | AUG | SEPT | OCT | NOV | DEC |
|---------------------|-----|-----|-----|-------|-----|------|------|-----|------|-----|-----|-----|
| BLOWER WHEEL | 2 | 2 | 2 | 2 | 2 | 2 | 2 | 2 | 2 | 2 | 2 | 2 |
| TOP BURNERS | 2 | 2 | 2 | 2 | 2 | 2 | 2 | 2 | 2 | 2 | 2 | 2 |
| BURNER GRATES | 2 | 2 | 2 | 2 | 2 | 2 | 2 | 2 | 2 | 2 | 2 | 2 |
| BURNER VALVES | 1,5 | | | 1,5 | | | | 1,5 | | | | 1,5 |
| DOOR SWITCHES | 1,3 | | | 1,3 | | | | 1,3 | | | | 1,3 |
| MOTOR | 1,2 | | | 1,2 | | | | 1,2 | | | | 1,2 |
| TOP BURNER PILOTS | 1,2 | | | 1,2 | | | | 1,2 | | | | 1,2 |
| OVEN PILOT | 1,2 | | | 1,2 | | | | 1,2 | | | | 1,2 |
| ROCKER SWITCHES | 1 | | | 1 | | | | 1 | | | | 1 |
| SAFETY VALVE | | | | | | 1,2 | | | | | | 1,2 |
| THERMOCOUPLE | 1,2 | | | 1,2 | | | | 1,2 | | | | 1,2 |
| THERMOSTAT | 1,3 | | | 1,3 | | | | 1,3 | | | | 1,3 |
| GREASE CONTAINER | 2 | 2 | 2 | 2 | 2 | 2 | 2 | 2 | 2 | 2 | 2 | 2 |
| AIR MIXERS | 2 | 2 | 2 | 2 | 2 | 2 | 2 | 2 | 2 | 2 | 2 | 2 |
| 1. CHECK | | | | | | | | | | | | |
| 2. CLEAN | | | | | | | | | | | | |
| 3. ADJUST | | | | | | | | | | | | |
| 4. REPLACE | | | | | | | | | | | | |
| 5. LUBRICATE | | | | | | | | | | | | |

NOTE* Maintenance schedule may vary due to the gas heating value per country.

SERVICE

IMPORTANT

WHEN SERVICE IS NEEDED, CONTACT A LOCAL SERVICE COMPANY, DEALER, OR FACTORY TO PERFORM MECHANICAL MAINTENANCE AND REPAIRS. THESE INSTRUCTIONS ARE INTENDED FOR USE BY COMPETENT SERVICE PERSONNEL.

CAUTION

TURN OFF GAS SUPPLY WHEN SERVICING GAS CONTROL SYSTEM.

PILOT SAFETY VALVE



P/N 34604-7

FIGURE 8. Pilot Safety

Model H15HR is an automatic 100% pilot safety which provides complete gas shut off in the event of a pilot failure. The safety valve is held closed by spring pressure. When red button is pushed by hand, gas flows to pilot. Pilot heats thermocouple creating a very small amount of electricity. This energizes a magnetic coil under the red button and holds the valve open, permitting gas to flow to main burner and pilot without holding pressure on red button. In the event of pilot failure, the flow of electricity will stop and spring will stop flow of gas to both pilot and oven burner.

NOTE: When replacing thermocouple, make sure that valve is clear of debris to allow for clean connection.

NOTE: When servicing a unit with a defective pilot safety valve, the whole valve should be replaced instead of just the magnetic head.

OVEN PILOT BURNER

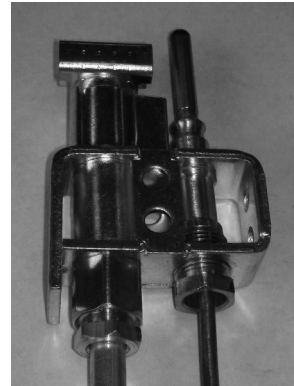

**PILOT ASSY. (NAT)- 23218-1
PILOT ASSY. (LP) - 23220-3
THERMOCOUPLE - 1013-8**

FIGURE 9. Oven Pilot

PILOT SERVICE IN THE EVENT OF PILOT FLAME FAILURE

1. If pilot flame burns yellow, clean pilot orifice and pilot burner to insure a steady blue flame. The pilot burner orifice can be cleaned by washing in a solvent and / or blowing out with air.
2. Flame must surround the thermocouple tip approximately 1/2". If the closed circuit check shows thermocouple output is greater than 8 millivolts and pilot will not remain lit when reset button is released, replace pilot safety valve.
3. Thermocouple lead connections must be tight, clean, and free of grease. The thermocouple nut should be started and turned all the way by hand. An additional quarter turn with a small wrench will then be sufficient.

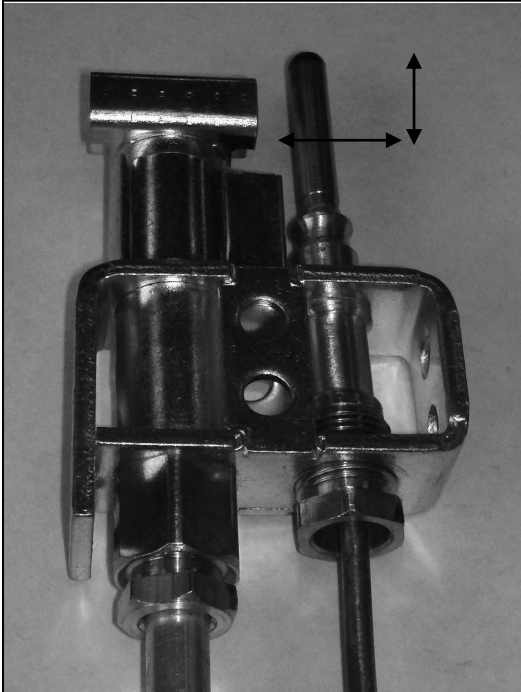

- Pilot flame should surround approximately 1/2" of the thermocouple.
- If flame burns yellow, replace pilot orifice.
- Correct gas pressure is important to maintain proper size pilot flame.
- When accessing pilot through oven bottom liner on a V series oven, reseal bottom liner with furnace cement to prevent pilot outages.

Figure 10. PILOT Flame Position

| THERMOCOUPLE OUTPUT | |
|------------------------------------|----------------------|
| CLOSED CIRCUIT MV RANGE | |
| NORMAL | NOT LESS THAN |
| 15-25 | 8 |

REMOVAL OF OVEN BURNER AND PILOT BURNER

CAUTION:

TURN OFF GAS AT MANUAL SHUT OFF VALVE NEXT TO THE APPLIANCE BEFORE ATTEMPTING TO LOOSEN ANY GAS CONNECTIONS.

1. Close manual shut off valve.
2. Remove burner access panel.
3. Remove screws from front of burner compartment front. Put top of panel forward and lift out.
4. Disconnect thermocouple of pilot supply tubing from safety valve.
5. Lift rear portion of burner up so that lugs will clear burner compartment bottom and slide burner toward the rear until air miser clears the orifice fitting.
6. Slide oven burner and pilot assembly out of burner compartment. To reassemble, reverse above procedure.

NOTE: Periodically check the condition of the stainless steel flame baffle (P/N 06139-5). If baffle has deteriorated or is severely warped, it should be replaced before the burner flames damage the oven bottom.

GAS PRESSURE REGULATOR

WARNING: NO UNTRAINED PERSON SHOULD ATTEMPT TO MAINTAIN OR SERVICE THE GAS PRESSURE REGULATOR.

REMOVAL OF THE FLAME BAFFLE AND HEAT BAFFLE ASSEMBLY

1. Remove oven racks and left and right rack guides.
2. Remove fan baffle.
3. Remove four screws on each side and three screws on back of oven interior liner bottom.
4. Pry liner bottom up and pull forward to remove from oven.
5. Lift heat baffle up and remove.
6. Remove flame baffle.

To reassemble, reverse above procedure.

CAUTION

OVERTIGHTENING MAY CAUSE DAMAGE TO THE THERMOCOUPLE OR MAGNET AND IS UNNECESSARY SINCE THIS IS AN ELECTRICAL CONNECTION.

FRY TOP THERMOSTAT



Figure 11. Fry Top Thermostat

The model BJ Robertshaw is a combination thermostat and gas valve. The gas is turned on and the temperature setting made by a single rotation of the dial. This valve automatically locks itself in the OFF position. To use, push dial inward, rotate counter-clockwise to the desired temperature. To shut gas off, rotate clockwise to OFF position.

This thermostat is a precision instrument carefully made and properly calibrated (i.e. the dial is properly set) at the factory to control temperatures accurately. The calibration should be verified upon installation of the equipment and periodically checked during preventative maintenance. The calibration of this thermostat should not be changed until considerable experience with cooking or test results have definitely proved that the thermostat is not maintaining the proper temperature.

CAUTION

THE RECALIBRATION SHOULD NOT BE MADE UNTIL THE BYPASS (MINIMUM BURNER) FLAME HAS BEEN PROPERLY ADJUSTED.

THERMOSTAT INSTALLATION

With front of the griddle raised, slide the thermostat bulb assembly into the support brackets attached to the underside of the fry top plate. Tighten the two holding screws. The excess capillary tube should be pulled forward and down as low as possible out of the heat zone, so that there is no chance of it coming in contact with the burner flame. Push the sleeving up against the bulb holder. A loose fit between the bulb holder and plate may damage the thermostat so that it will not control the temperature of the fry top plate.

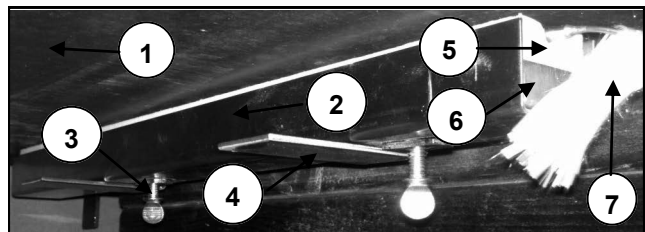

- 1. Fry Top plate
- 2. Shield
- 3. Screw, holding
- 4. Bracket, support
- 5. Insulated block
- 6. Backing plate
- 7. Sleeving

Figure 12. Thermostat Sensing Bulb Holder Assembly

ADJUSTMENT OF BYPASS (MINIMUM BURNER) FLAME

This is the flame which must be maintained on the burners when the fry top has reached the temperature set on the dial. Enough gas must be bypassed by the control to keep the entire burner lit. The thermostat regulates the flame from high to low in accordance with the fry top temperature and will automatically turn down to this bypass flame when the temperature set on the dial is attained.

Special care should be taken to see that the thermostat bulb is in its proper place and no part of the capillary tube is in any flame or heat zone. The fry top plate should never be removed without first removing the thermostat bulb(s) from beneath the plate. Never allow capillary tube to be kinked or crushed.

NOTE: If the bypass is not set correctly, it will affect the set temperature.

FRY TOP THERMOSTAT CALIBRATION CHECK:

NOTE: The fry top temperature should be checked or recalibrated with fry top hot.

NOTE: See "Adjustment Of Bypass (Minimum Burner) Flame" before recalibrating this thermostat.

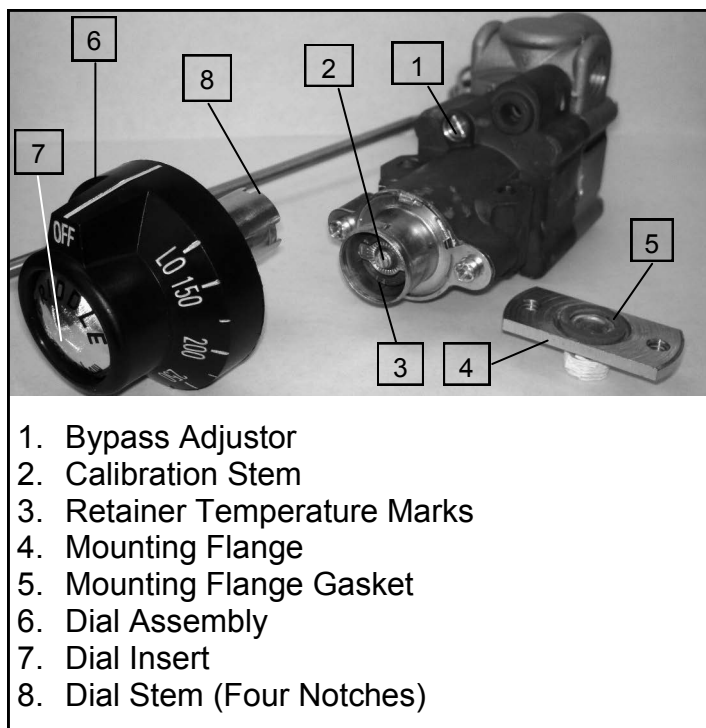

Figure 13. Griddle Thermostat Components

HOT CHECK METHOD

1. Place reliable thermometer in center of the top of the fry top over the thermal bulb.
2. Set Dial (6) to 350 degrees F.
3. Wait until temperature rises and remains constant.
4. If dial does not agree with thermometer readings, slip off Dial (6) and push out metal insert (7).
5. Replace dial, turn to 350 degree mark.
6. Hold dial firmly, insert screwdriver through center of dial and push calibration stem (2) inward. **DO NOT TURN THIS STEM.**
7. While holding calibration stem (2) in firmly with screwdriver, turn dial until it is set at the actual fry top temperature as shown by the thermometer. Release pressure on calibration stem. Replace dial insert (7).

THE BYPASS MUST BE SET CAREFULLY AND ACCURATELY AS FOLLOWS:

1. Light burners and turn Dial (6) counterclockwise to the LO setting, if the burner goes out entirely, the bypass is closed.
2. Slip off Dial (6). Remove the valve panel from the front of the range.
3. With a screwdriver, turn bypass adjuster (1). Turning it out counterclockwise increases the bypass flame; turning it in clockwise decreases the bypass flame. Adjust until there is a flame approximately 1/8" high over the entire burner.
4. Replace dial, rotating dial clockwise until it snaps into its original position.
5. Reinstall the valve panel on front of the range.

OVEN THERMOSTAT - 136 SERIES

All adjustments are accessible from the front of the range after the dial and the front panel have been removed. To remove dial, grasp knob portion firmly and pull. This will expose the calibration plate. Dial is held to the shaft with a friction fit. There are no screws.

Verification of calibration is advised upon installation of the equipment to insure that the unit is maintaining the temperature to which the dial is set. To check oven temperatures when recalibrating use a reliable test instrument or oven thermometer. A laser thermometer is not advised because of varying results.

CAUTION

THE RECALIBRATION SHOULD NOT BE MADE UNTIL THE BYPASS (MINIMUM BURNER) FLAME HAS BEEN PROPERLY ADJUSTED.

ADJUSTMENT OF BYPASS (MINIMUM BURNER FLAME) - 136 SERIES

Enough gas must be bypassed through the heat control to keep the entire burner lit while in use. The control regulates the flame from high to low.

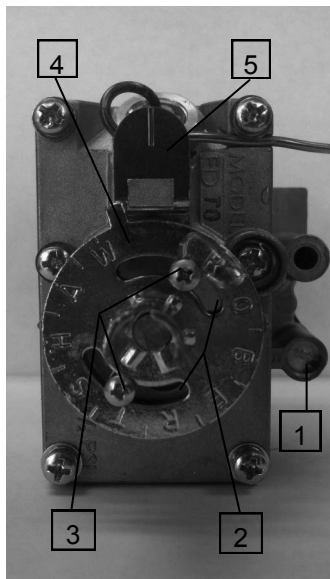

1. Bypass Adjustor
2. Screw Clearance
3. Calibration Screws
4. Calibration Plate
5. Dial Stop

Figure 14. Oven Thermostat Components

PROCEDURE:

1. Turn dial to 300 degrees F.
2. Light main burner.
3. After oven temperature rises and remains constant, turn dial back to low. This closes main valve and permits only the bypass gas to the burner.
4. Remove dial.
5. With a screwdriver, turn the bypass flame adjustor screw counterclockwise to increase the bypass flame or clockwise to decrease it until the flame over the entire burner is approximately 1/8" high. Replace dial.

THERMOSTAT CALIBRATION CHECK 136 SERIES

1. Place the thermocouple of test instrument or thermometer in the middle of the oven.
2. Light the main burner.
3. Turn dial so 350 lines up with the indicator mark on dial stop.
4. Allow the oven to heat until flame cuts down to bypass. After sufficient time, check temperature. If the temperature does not read within 15 degrees of the dial setting, recalibrate as follows:
 - A.) Pull dial straight off without turning.
 - B.) Hold calibration plate and loosen the two calibration lock screws until the plate can be moved independently of the control.
 - C.) Turn calibration plate so that the instrument or thermometer reading is in line with the indicator mark. Hold plate and tighten screws firmly. On controls where the plate has no temperature markings, use a chart to determine the temperature degree between letters. Turn the calibration plate counter-clockwise if the test reading is higher than the dial setting, or clockwise if the reading is lower than the dial setting.
 - D.) Replace dial.

NOTE: If the above adjustment is prevented by the two loosened calibration lock screws being in contact with the ends of the screw clearance slots in the calibration plate, remove the screws and after turning the calibration plate to the proper location, reassemble screws in the other tapped holes designed for them.

| RECALIBRATION CHART | | |
|---------------------|---------------------------|------------------|
| Dial Range | Degrees F Between Letters | Calibration Mark |
| 200-500 | 50 Degrees | 350 Degrees |

OVEN THERMOSTAT - 124 SERIES

The Model BJ Robertshaw is a combination thermostat and gas valve. The gas is turned on and the temperature setting made by a single rotation of the dial. This valve automatically locks itself in the OFF position. To use, push inward, rotate counterclockwise to the desired temperature. To shut gas off, rotate clockwise to OFF position.

This thermostat is a precision instrument carefully made and properly calibrated (i.e. the dial is properly set) at the factory to control temperatures accurately. The calibration should be verified upon installation of the equipment and periodically checked during preventative maintenance. The calibration of this thermostat should not be changed until considerable experience with cooking or test results have definitely proved that the thermostat is not maintaining the proper temperature.

CAUTION

THE RECALIBRATION SHOULD NOT BE MADE UNTIL THE BYPASS (MINIMUM BURNER) FLAME HAS BEEN PROPERLY ADJUSTED.

ADJUSTMENT OF BYPASS (MINIMUM BURNER) FLAME - 124 SERIES

This is the flame that must be maintained on the burner when the oven has come up to the temperature set on the dial. Enough gas must be bypassed by the control to keep the entire burner lit. The thermostat regulates the flame from high to low in accordance with the oven temperature and will automatically turn down to this bypass flame when temperature set on the dial is attained in the oven.

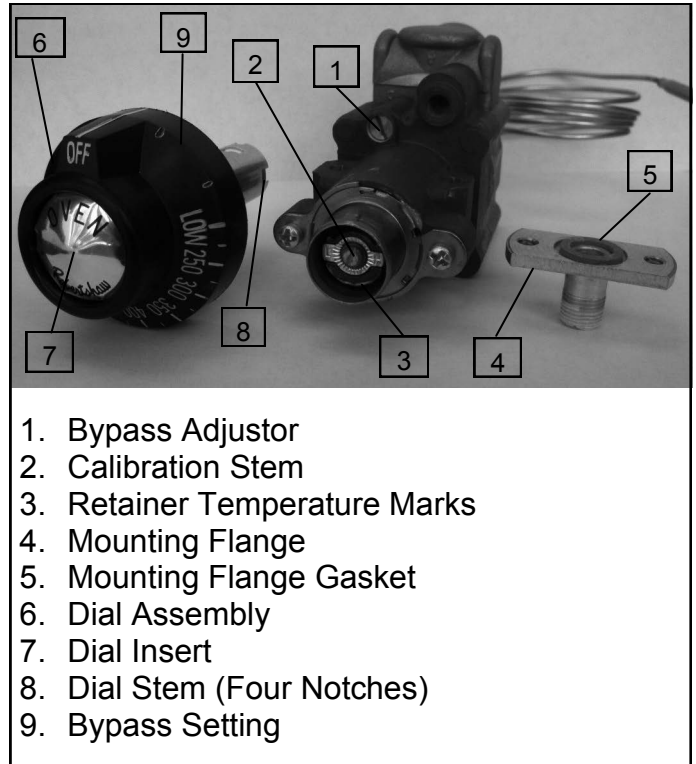

Figure 15. 124 Oven Thermostat Components

THE BYPASS MUST BE SET CAREFULLY AND ACCURATELY AS FOLLOWS:

1. Light burners and turn Dial (6) counterclockwise and to a point midway between the "Gas On" mark and next graduation to the right of it (shown by #9). If the burner goes out entirely, the bypass is closed.
2. Slip off Dial (6). Remove valve panel from front of range.
3. With a screwdriver, turn Bypass Adjustor (1). Turning it out counterclockwise increases the bypass flame; turning it in clockwise decreases the bypass flame. Adjust until there is a flame approximately 1/8" high over the entire burner.
4. Replace dial, rotating dial clockwise until it snaps into its original position.
5. Reinstall valve panel on front of range.

OVEN THERMOSTAT CALIBRATION CHECK 124 SERIES

NOTE: The oven temperature should be checked or recalibrated with oven hot.

NOTE: See "Adjustment of Bypass (Minimum Burner) Flame" above before recalibrating this thermostat.

HOT CHECK METHOD

1. Place the reliable thermometer in center of oven.
2. Set dial (6) at 350 degrees F.
3. Wait until temperature rises and remains constant.
4. If dial does not agree with thermometer readings, slip off Dial (6) and push out insert (7).
5. Replace dial, turn to 350 degree mark.
6. Hold dial firmly, insert screwdriver through center of dial and push calibration stem (2) inward. **DO NOT TURN THIS STEM.**
7. While holding calibration stem (2) in firmly with screwdriver, turn dial until it is set at the actual oven temperature as shown by your test instrument or thermometer. Release pressure on calibration stem. Replace dial insert.

OPERATIONAL DIFFICULTIES & PROBABLE CAUSES

OVEN PILOT BURNER GOES OUT:

1. Gas shut off.
2. Poor draft in flue snuffs out flame.
3. Too much draft pulls flame away from thermocouple.
4. Pilot flame too low.
5. Thermocouple defective.
6. Thermocouple connection on safety pilot loose.
7. Pilot orifice dirty.
8. Pilot Safety valve defective.
9. Gas leak at pilot orifice fitting.
10. Restricted or plugged vent on gas pressure regulator.

OVEN BURNER FAILS TO COME ON (PILOT ON):

1. Burner valve off.
2. Burner orifice plugged.
3. Thermostat out of calibration.
4. Minimum flame adjustment closed and thermostat setting too low.

OVEN TEMPERATURE HIGHER THAN DIAL SETTING:

1. Oven thermostat out of calibration.
2. Minimum flame too high. (Do not lower under 1/8").
3. Broken capillary tube on the thermostat
4. Dirt under thermostat valve seat.

 **CAUTION**

BEFORE REPLACING OVEN INTERIOR LINER BOTTOM, SEAL THE SIDE AND REAR FLANGES WITH FURNACE CEMENT TO PREVENT AIR LEAKS INTO COMBUSTION CHAMBER. AIR LEAKS INTO THE COMBUSTION CHAMBER COULD ADVERSELY AFFECT BURNER OPERATION.

REMOVAL OF MOTOR AND BLOWER WHEEL ASSEMBLY

 **CAUTION**

DISCONNECT ELECTRICAL POWER TO RANGE BEFORE SERVICING.

1. Remove oven racks from the interior.
2. Remove the four thumbscrews holding the fan baffle and remove fan baffle from oven.
3. Remove the ten nuts holding the motor mounting plate assembly to the back of the oven.
4. Pull plate forward so that the motor flange clears 10" diameter in oven back panel. The first time motor is removed, the 1/8" thick rectangular insulation pad between motor and oven back panel will have to be forced through 10" diameter hole. Pull motor back completely through hole and rest on oven bottom.
5. Remove cover from junction box on motor and disconnect wire leads. (Mark wire leads for identification during reconnection.)
6. Disconnect flexible conduit from junction box. Motor, mounting plate, and blower wheel may then be removed from the oven.

Blower Wheel Removal:

1. Loosen the two Allen set screws on the blower wheel hub.
2. Using a wheel puller, remove the blower wheel from the motor shaft. A flange on the blower wheel hub is provided for this purpose.

Motor Removal from the Mounting Plate:

Remove four nuts from motor mounting bolts and remove motor.

To reassemble, reverse the above procedure.

IMPORTANT: WHEN INSTALLING BLOWER WHEEL ON MOTOR SHAFT, POSITION BLOWER WHEEL SO THAT IT WILL NOT RUB AGAINST BOLT HEADS ON MOUNTING PLATE OR CONTACT FAN BAFFLE.

MOTORS

The following is used on the oven:

ELECTRICAL CHARACTERISTICS

| PART NO. | MFR | HP | SPEED | VOLTAGE | HZ | PH |
|-----------------|------------|-----------|--------------|----------------|-----------|-----------|
| 06382-7 | Baldor | 1/4 | 1 | 115/230 | 60 | 1 |

DOOR SWITCH



CAUTION

DISCONNECT ELECTRICAL POWER TO RANGE BEFORE SERVICING

The switch should be adjusted so that when the door is opened one-quarter inch, the switch shuts off the blower. The switch is located behind the burner access panel on the right side next to the door post.

ADJUSTMENT

1. Loosen the two nuts on front of door switch bracket.
2. Turn back-up nuts inward to increase opening to 1-1/4 or turn back-up nuts outward to decrease opening. With no power on oven, the switch is adjusted by the sound of the switch clicking.

REPLACEMENT

1. Remove switch cover.
2. Carefully disconnect wires from switch.
3. Remove nuts from microswitch mounting screws.
4. Follow above steps in replacing parts in reverse order.



CAUTION

Check that washers are in place between microswitch and bracket and the insulated terminal (without wire lead) is replaced on NC terminal of microswitch.

5. Adjust microswitch operation as described in ADJUSTMENT.

SERVICE

OPERATIONAL DIFFICULTIES & PROBABLE CAUSES

OVEN PILOT BURNER GOES OUT:

1. Gas shut off.
2. Poor draft in flue snuffs out flame.
3. Too much draft pulls flame away from thermocouple.
4. Pilot flame too low.
5. Thermocouple defective.
6. Thermocouple connection on safety pilot valve loose.
7. Pilot orifice dirty.
8. Safety pilot valve defective.
9. Gas leak at pilot orifice fitting.
10. Restricted or plugged vent on gas pressure regulator.
11. Incorrect gas pressure setting on pressure regulator.
12. Make up air in kitchen blowing at flue outlet.

OVEN BURNER FAILS TO COME ON (PILOT ON):

1. Burner valve off.
2. Burner orifice plugged.
3. Thermostat out of calibration.
4. Minimum flame adjustment closed and thermostat setting too low.

OVEN TEMPERATURE HIGHER THAN DIAL SETTING:

1. Oven thermostat out of calibration.
2. Minimum flame too high (do not lower under 1/8").
3. Broken capillary tube on thermostat.
4. Dirt under thermostat valve.

Heavy Duty Fry Top (1)

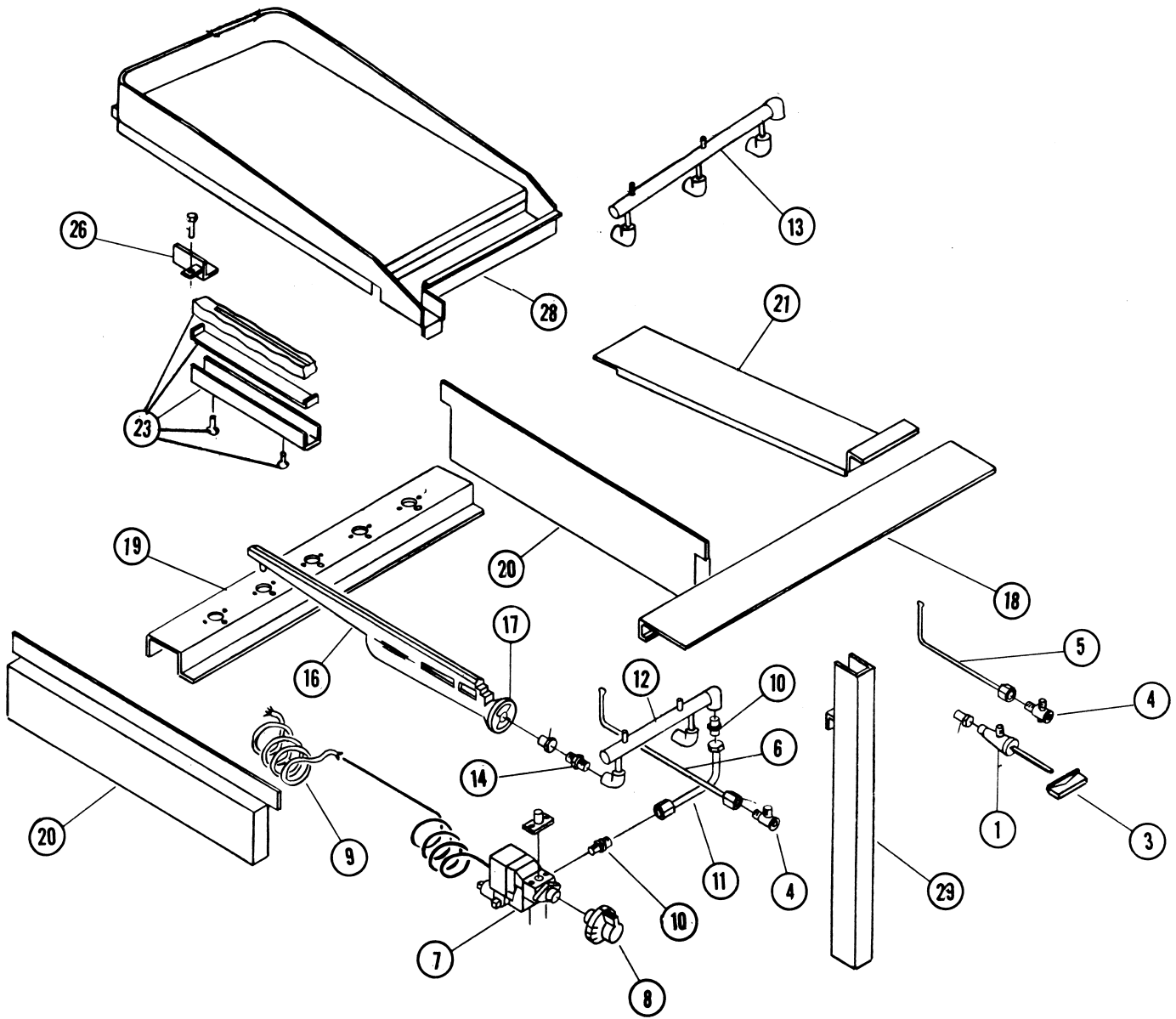

| ITEM | PART NO. | DESCRIPTION | ITEM | PART NO. | DESCRIPTION |
|------|----------|------------------------------------|------|----------|--|
| 1 | 04330-3 | Valve, Top Burner- Nat | 18 | 09302-5 | Support-- Front, Air Baffle - 24" |
| 1 | 01003-0 | Valve, Top Burner- LP | 18 | 09303-3 | Support-- Front, Air Baffle - 18" |
| 3 | 02002-8 | Handle, Valve w/ set screw | 18 | 09304-1 | Support-- Front, Air Baffle - 12" |
| 4 | 01055-3 | Valve, Pilot | 19 | 07127-7 | Support , Burner - 36" |
| 5 | 03416-9 | Pilot Lighter (without thermostat) | 19 | 07130-7 | Support , Burner - 24" |
| 6 | 03418-5 | Pilot Lighter (with thermostat) | 19 | 07128-5 | Support , Burner - 18" |
| 7 | 03367-7 | Thermostat, Griddle- BJWA w/ Dial | 19 | 07129-3 | Support , Burner - 12" |
| 8 | 01022-7 | Dial, Thermostat | 20 | 03560-2 | Baffle- Heat Assy |
| 9 | 07125-0 | Insulation Sleeve for Capillary | 21 | 03533-5 | Baffle- Air Assy 3 1/8" Small |
| 10 | 01271-8 | Fitting 1/4" NPT x 7/16" | 21 | 03540-8 | Baffle- Heat Assy 5 1/8" Medium |
| 11 | ---- | Aluminum Tubing 7/16" | 23 | 03386-3 | Thermal Bulb Holder - Complete |
| 12 | 01109-7 | Manifold 2 Burner | 26 | 06004-6 | Adjusting Bracket w/ Bolt, Left |
| 13 | 01104-5 | Manifold 3 Burner | 26 | 06005-4 | Adjusting Bracket w/ Bolt, Right (not shown) |
| 14 | 02407-4 | Fitting - Hex w/ Orifice- Nat | 28 | ---- | Fry Top |
| 14 | 01059-6 | Fitting - Hex w/ Orifice- LP | 29 | 03368-5 | Container, Grease - Painted |
| 16 | 03362-6 | Burner, complete | 29 | 02150-4 | Container, Grease - Chromed |
| 17 | 02037-0 | Air Mixer, Burner | | | |
| 18 | 10913-4 | Support-- Front, Air Baffle - 36" | | | |

Heavy Duty Fry Top (2)

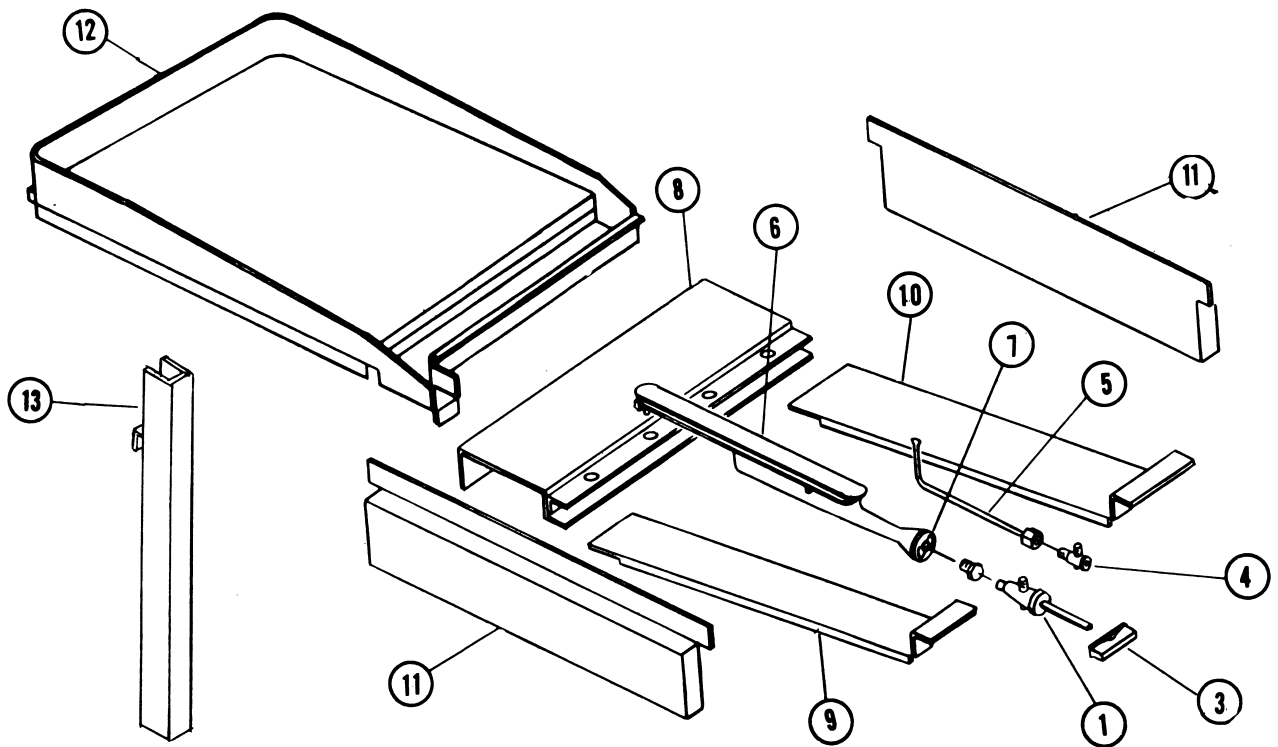

| ITEM | PART NO. | DESCRIPTION |
|------|----------|--------------------------------|
| 1 | 01002-2 | Valve, Top Burner - L.P. |
| 3 | 02002-8 | Handle, Valve w/ Set Screw |
| 4 | 01055-3 | Valve, Pilot |
| 5 | 03416-9 | Pilot Lighter |
| 6 | 03361-8 | Burner- Complete |
| 7 | 02038-9 | Air Mixer |
| 8 | 03559-9 | Support, Burner - 36" Unit |
| 8 | 03541-6 | Support, Burner - 24" Unit |
| 8 | 01726-9 | Support, Burner - 18" Unit |
| 8 | 03096-1 | Support, Burner - 12" Unit |
| 9 | 03533-5 | Baffle- Air Assy 3 1/8" Small |
| 10 | 03540-8 | Baffle- Air Assy 5 1/8" Medium |
| 11 | 03560-2 | Baffle- Heat Assy |
| 12 | | Frytop |
| 13 | 03368-5 | Container, Grease- Painted |
| 13A | 02150-4 | Container, Grease- Chromed |

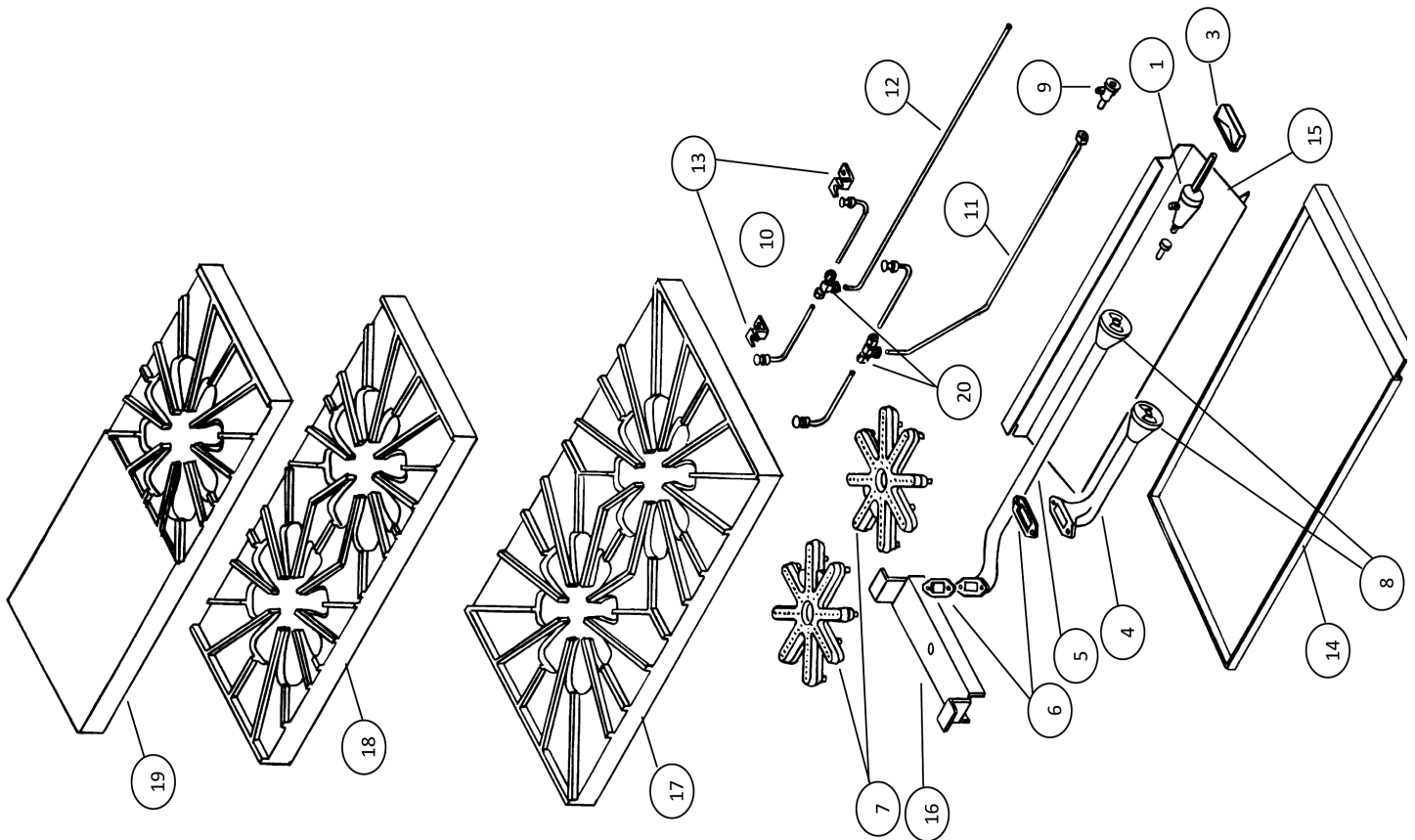

| ITEM | PART NO. | DESCRIPTION |
|-------------|----------|---|
| 1 | 04330-3 | Valve, Top Burner (Nat) *Except 1/2 Hot Top |
| 1 | 01003-0 | Valve, Top Burner (LP) *Except 1/2 Hot Top |
| 1 | 02405-8 | Valve, Top Burner (Nat) *1/2 Hot Top Only |
| 1 | 01002-2 | Valve, Top Burner (LP) *Except 1/2 Hot Top |
| 3 | 02002-8 | Handle, Valve w/ Set Screw |
| 4 | 03348-0 | Venturi, Front Burner |
| 4, 6, 7, 8 | 03347-2 | Burner, Front - Complete |
| 5 | 03350-2 | Venturi, Rear Burner (Left Wing shown) |
| 5, 6, 7, 8 | 03349-9 | Burner, Rear Left - Complete |
| 5A, 6, 7, 8 | 03351-0 | Burner, Rear Right - Complete (not shown) |
| 6 | 02115-6 | Gasket |
| 7 | 03346-4 | Burner Head Only |
| 8 | 02038-9 | Air Mixer |
| 9 | 01055-3 | Pilot Valve |
| 10 | 03583-1 | Lighter, Pilot |
| 10, 11, 20 | 03431-2 | Pilot Kit - 12" Section (less valve) |
| 10, 12, 20 | 03430-4 | Pilot Kit - 18" Section (less valve) |
| 20, 21, 22 | 07142-0 | Pilot Kit - 12" -59 Section (less value) |
| 13 | 01518-0 | Pilot Bracket |
| 14 | 03379-0 | Drip Tray - 36" unit *** |
| 14 | 03378-2 | Drip Tray - 24" unit *** |
| 14 | 03377-4 | Drip Tray - 18" & "12" unit *** |
| 15 | 03380-4 | Drip Tray Guide |
| 16 | 03498-3 | Support, Open Burner 36" Unit *** |
| 16 | 03530-0 | Support, Open Burner 24" Unit *** |
| 16 | 03531-9 | Support, Open Burner 18" Unit *** |
| 16 | 03532-7 | Support, Open Burner 12" Unit *** |
| 17 | 03480-0 | 18" Open Top |
| 18 | 03580-7 | 12" Open Top |
| 19 | 03482-7 | 12" Combination -59 Top (1/2 Hot Top) |
| 22 | 06232-4 | Lighter, Pilot |
| 23 | 03556-4 | Bracket, Pilot MTG (-59 Top) |

* Specify Type of Gas & Manifold Pressure

** Specify Left or Right Swing

***Specify Width

MONTAGUE HEAVY DUTY GAS RANGE
HOT TOP SECTION 18" WIDE FRONT FIRED

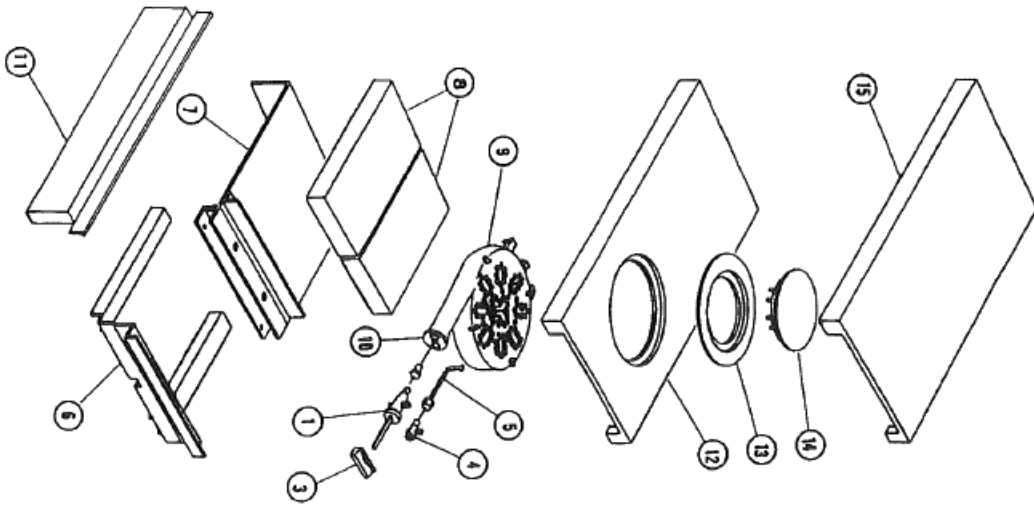

PLEASE ORDER BY PART NO. AND DESCRIPTION

| ITEM | PART NO. | DESCRIPTION |
|------|----------|--|
| 1 | 02408-2 | Valve, Top Burner - Nat. |
| 2 | 02405-8 | Valve, Top Burner - LP |
| 3 | 02002-8 | Handle, Valve w/Set Screw |
| 4 | 01055-3 | Valve, Pilot |
| 5 | 03419-3 | Pilot Lighter |
| 6 | 04412-1 | Baffle-Air Assy - 36" Unit |
| 7 | 04414-8 | Baffle-Air Assy - 18" Unit |
| 8 | 04281-1 | Burner & Brick Support - 36" Unit |
| 9 | 04298-6 | Burner & Brick Support - 18" Unit |
| 10 | 01764-7 | Brick (1-1/4 x 8 x 13) |
| 11 | 03356-1 | Burner, 18" Hot Top - Complete (Right Swing) |
| 12 | 03355-3 | Burner, 18" Hot Top - Complete (Left Swing) |
| 13 | 02037-0 | Air Mixer |
| 14 | 03560-2 | Insulated Side Shield |
| 15 | 01743-4 | Hot Top - 18" M/Ring & Cover |
| | 01745-0 | Hot Top - 18" M/Ring & Cover |
| | 01747-7 | Hot Top - 18" M/Ring & Cover |
| | 01741-8 | Hot Top - 18" - Solid |

- △ Specify Gas & Mantfold Pressure
- △ Specify Swing
- △ Specify Width

No. 105C-1 1186

MONTAGE HEAVY DUTY GAS RANGE
HOT TOP SECTION 12" WIDE FRONT FIRED

PLEASE ORDER BY PART NO. AND DESCRIPTION

| ITEM | PART # | DESCRIPTION |
|------|---------|-----------------------------------|
| 1 | 02406-6 | Valve, Top Burner - Nat |
| 3 | 01003-0 | Valve, Top Burner - Lp |
| 3 | 02002-8 | Handle, Valve W/Set Screws |
| 4 | 01055-3 | Valve, Pilot |
| 5 | 03421-5 | Pilot Lighter |
| 6 | 04239-4 | Burner Support W/Insulation - 36" |
| 6 | 04284-6 | Burner Support W/Insulation - 24" |
| 6 | 04283-8 | Burner Support W/Insulation - 12" |
| 7 | ----- | Insulation Pad |
| 9 | 03353-7 | Burner, 12" Hot Top |
| 10 | 02038-9 | Air Mixer |
| 11 | 01635-7 | Baffle, Burners - Cast Iron |
| 12 | 03560-2 | Manifold Shield W/Stops |
| 13 | ----- | Insulated Side Shield |
| 14 | 01738-8 | Hot Top - 12" Section |

- 3 Specify Gas & Manifold Pressure
- 6 Specify Width

MONTAGE HEAVY DUTY GAS RANGE
HOT TOP SECTION - EVEN HEAT 12" AND 18" WIDE

PLEASE ORDER BY PART NO. AND DESCRIPTION

| ITEM | PART NO. | DESCRIPTION |
|------|----------|--------------------------------------|
| 1 | 04130-3 | Valve, Top Burner - Nat |
| 1 | 01003-0 | Valve, Top Burner - Lp |
| 3 | 02002-8 | Handle, Valve W/Set Screw |
| 4 | 01055-3 | Valve, Pilot |
| 5 | 03416-9 | Pilot Lighter |
| 6 | 03562-6 | Burner, Even Heat Hot Top - Complete |
| 7 | 02037-0 | Air Mixer |
| 8 | 10628-3 | Support, Burner - 36" |
| 8 | 04468-7 | Support, Burner - 24" |
| 8 | 10629-1 | Support, Burner - 18" |
| 8 | 07133-1 | Support, Burner - 12" |
| 9 | 03560-2 | Baffle - Heat Assy. |
| 10 | 03533-5 | Baffle - Air Assy. 3-1/8" wide |
| 10 | 03538-6 | Baffle - Air Assy. 9-1/4" wide |
| 11 | 01738-8 | Hot Top, 12" Section |
| 12 | 01741-8 | Hot Top, 18" Section |

- 3 Specify Gas & Manifold Pressure
- 6 Specify Width

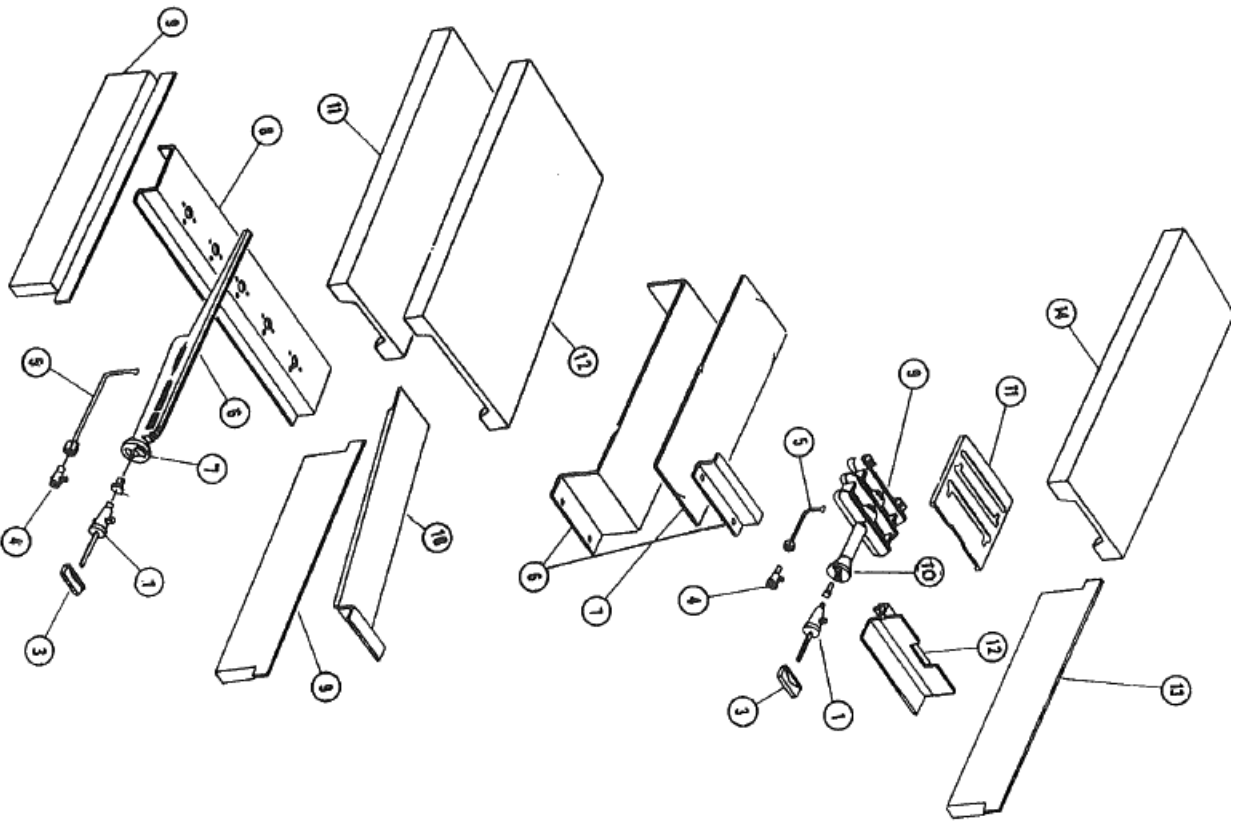

124 & 136XLB EXPLODED VIEW

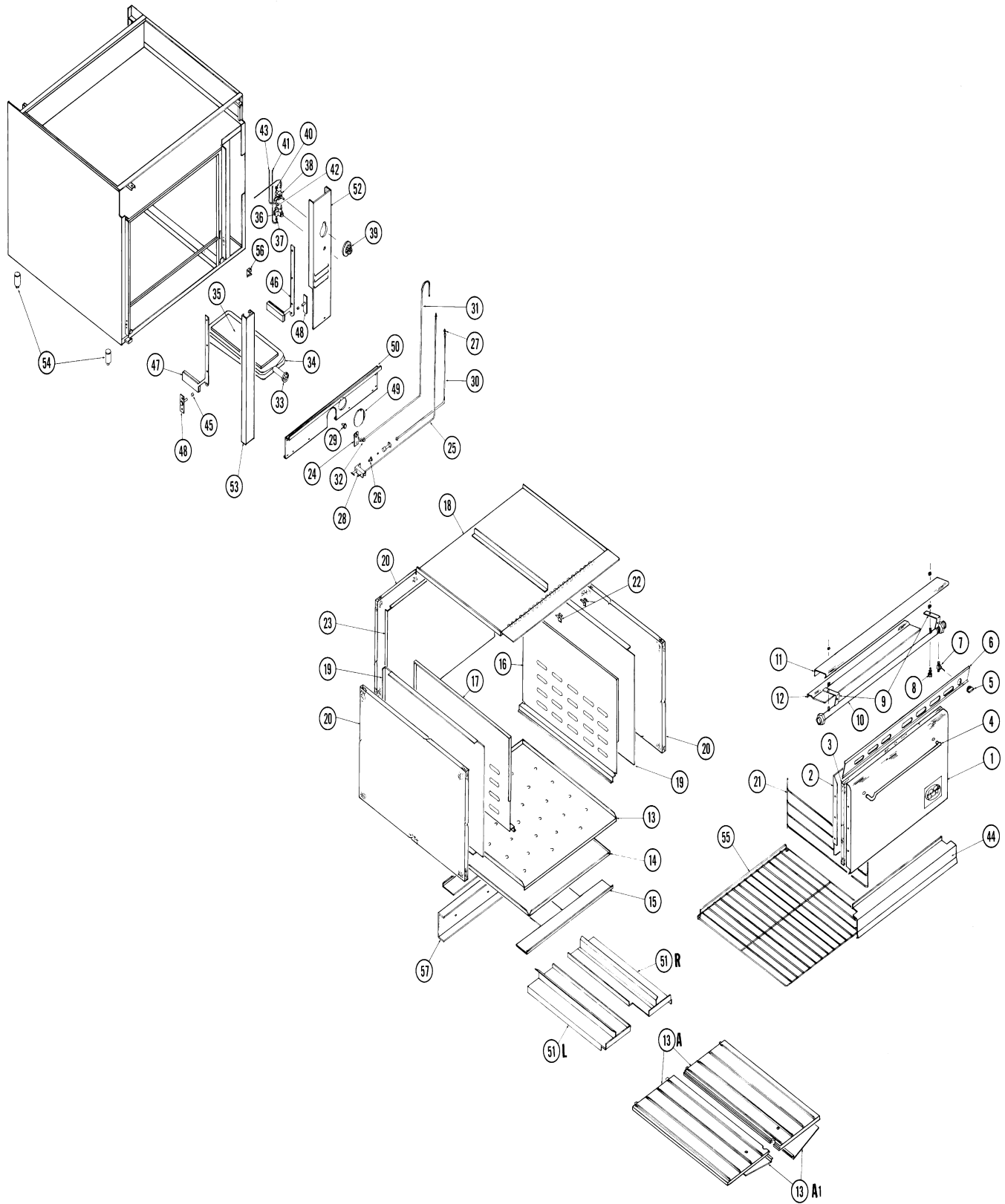

Heavy Duty 136 Series

124 & 136XLB Series Only

| Item | Part # | Description | Item | Part # | Description |
|-----------|---------|---|----------|---------|---|
| 1..... | 06135-2 | Door Panel, Exterior - S/S | 1..... | 31081-6 | Door Panel, Ext. - S/S; 136XLB |
| 2..... | 11794-3 | Door Liner, Interior | 1..... | 31679-2 | Door Panel, Ext. - S/S; 124 Series (w/o Logo) |
| 3..... | 01424-9 | Insulation, Door | 2..... | 32536-8 | Door Panel, Int. - Porcelain; 124 Series |
| 4..... | 11776-5 | Handle, Door (25 Inches) | 2..... | 31680-6 | Door Panel, Int. - Opt. S/S. 124 Series |
| 5..... | 38485-2 | Handle, Main Oven Valve | 2..... | 32611-9 | Door Panel, Int. - Porcelain; 136XLB |
| 6..... | 38286-8 | Valve Panel - 36", S/S | 2..... | 31067-0 | Door Panel, Ext. - S/S; Opt. 136XLB |
| 6..... | 38935-8 | Valve Panel - 34" (Frytop) | 3..... | 07631-7 | Insulation, Door - 124 Series |
| 7..... | 36174-7 | Valve Oven (3/8 NPT x 7/16CC) | 3..... | 32612-7 | Insulation, Door - 136XLB |
| 8..... | 36142-9 | Pilot Shutoff (1/8 NPT x 1/4CC) | | 32623-2 | Door Assembly - 136XLB (w/o handle) Porc. |
| 9..... | 06137-9 | Bracket, Valve Panel | | 32522-8 | Door Assembly - 136XLB (w/o handle) S/S |
| 10..... | 36268-9 | Manifold, 36" (Order by model) | | 32738-7 | Door Assembly - 124 Series (w/o handle) |
| 10..... | 33763-3 | Manifold, 36" w/ 1" RC | 4..... | 11805-2 | Handle, Door - 124 Series |
| 11..... | 19773-4 | Guard Rail, 36" S/S | 6..... | 31686-5 | Valve Panel - 24" S/S; 124 Series |
| 11..... | 19775-0 | Guard Rail, 34" S/S | 8..... | 32739-5 | Valve, Pilot Shutoff - (1/8 NPT x 1/4CC) 124 |
| 12..... | 04285-4 | Drip Shield, Manifold | 10..... | 32691-7 | Manifold - 124 Series (order by model) |
| 13..... | 09051-4 | Oven Bottom, Porcelain | 11..... | 06913-2 | Guard Rail - S/S; 124 Series (w/o hardware) |
| 13A..... | 04387-7 | Oven Bottom, Cast Iron (Pair) | 12..... | 32585-6 | Manifold Drip Shield Assy. - 124-5, 559 |
| 13A1..... | 07987-1 | Heat Deflector, for 13A Bottom | 13..... | 32539-2 | Oven Bottom - Porcelain; 124 Series |
| 14..... | 04601-9 | Heat Deflector | 13..... | 31684-9 | Oven Bottom - Opt. S/S; 124 Series |
| 15..... | 06593-5 | Burner Baffle, S/S | 15..... | 32630-5 | Burner Baffle - S/S; 124 Series |
| 16..... | 09044-1 | Side Liner, Oven - Right | 16..... | 32600-3 | Side Liner, Oven Rt - Porcelain 136XLB |
| 17..... | 09043-3 | Side Liner, Oven - Left | 16..... | 32527-9 | Side Liner, Oven Rt - S/S 136XLB |
| 18..... | 01538-5 | Top Liner, Oven - Porcelain | 17..... | 32599-6 | Side Liner, Oven Lt - Porcelain 136XLB |
| 19..... | 12874-0 | Interior Liner, Left & Right (W/ Stiffener) | 17..... | 32526-0 | Side Liner, Oven Lt - S/S 136XLB |
| 20..... | 12894-5 | Insulation, Oven - Left, Right & Rear | 18..... | 32605-4 | Top Liner, Oven - Porcelain; 136XLB |
| 21..... | 07223-0 | Rack Guide - Left or Right | 18..... | 32528-7 | Top Liner, Oven - S/S; 136XLB |
| 22..... | 01942-9 | Clip, Thermostat Bulb | 18..... | 32545-7 | Top Liner, Oven - Porcelain; 124 Series |
| 23..... | 01536-9 | Rear Liner, Oven - Porcelain | 18..... | 32703-4 | Top Liner, Oven - S/S; 124 Series |
| 24..... | 06149-2 | Bracket, Orifice Fitting - Oven | 19..... | 31079-4 | Interior Liner, Lt/Rt; 136XLB |
| 25..... | 01013-8 | Thermocouple 30" | | 32463-9 | Spacer |
| 26..... | 34177-0 | Orifice, Oven Pilot (Nat. Gas) | 19..... | 32709-3 | Liner Spacer - S/S; 124 Series |
| 26..... | 02191-1 | Orifice, Oven Pilot (L.P. Gas) | 21..... | 32530-9 | Rack Guide - Lt/Rt |
| 27..... | 06155-7 | Compression Nut & Ferrell - 1/4" Tube | 23..... | 32608-9 | Rear Liner, Oven - Porcelain; 136XLB |
| 28..... | 23218-1 | Oven Pilot Burner (Nat. Gas) | 23..... | 31072-7 | Rear Liner, Oven - S/S; 136XLB |
| 28..... | 23220-3 | Oven Pilot Burner (L.P. Gas) | 23..... | 32542-2 | Rear Liner, Oven - Porcelain; 124 Series |
| 29..... | 02361-2 | Orifice, Main Burner (Nat. Gas) | 23..... | 31685-7 | Rear Liner, Oven - Opt. S/S; 124 Series |
| 29..... | 06151-4 | Orifice, Main Burner (L.P. Gas) | 29..... | 04338-9 | Orifice, Main Burner - 136XLB Oven (Nat) |
| 30..... | 03604-8 | Tubing 1/4" (Safety Valve to Pilot Burner) | 29..... | 02257-0 | Orifice, Main Burner - 136XLB Oven (L.P.) |
| 31..... | 03602-1 | Tubing 7/16" (Thermostat to Burner-42") | 30..... | 01225-4 | Tubing - 1/4" ; 124 Series (Safety to Pilot) |
| 32..... | 31050-6 | Elbow Assy. W/Orifice (Nat. Gas) | 31..... | 15909-3 | Tubing - 3/8" ; 124 Series (T-stat to Safety) |
| 32..... | 06153-0 | Elbow Assy. W/Orifice (L.P. Gas) | 32..... | 22903-2 | Elbow Assy. w/orifice - 136XLB Oven (Nat) |
| 33..... | 02037-0 | Air Mixer, Oven Burner | 32..... | 32723-9 | Elbow Assy. w/orifice - 136XLB Oven (L.P.) |
| 34..... | 06349-5 | Burner Assembly, Oven (Nat. Gas) | 32..... | 14610-2 | Elbow Assy. w/orifice - 124 Series (Nat.) |
| 34..... | 06350-9 | Burner Assembly, Oven (L.P. Gas) | 32..... | 02586-0 | Elbow Assy. w/orifice - 124 Series (L.P.) |
| 35..... | 09518-4 | Baffle, Main Oven Burner | 34..... | 03361-8 | Burner, Oven - 124 Series |
| 36..... | 34604-7 | Safety Valve, Pilot | 36..... | 29766-6 | Safety Valve Assembly - 124 Series |
| 37..... | 01277-7 | Compression Fitting, Tapered - 1/4" Tube | 38..... | 11810-9 | Thermostat, BJWA - 124 Series |
| 38..... | 01061-8 | Thermostat, FDTO (500 degrees) | 39..... | 32706-9 | Dial, Oven Thermostat - BJWA ; 124 Series |
| 39..... | 01977-1 | Thermostat Dial (FDTO) | 40..... | 01281-5 | Fitting - 3/8"NPT x 3/8"CC - 124 Series |
| 40..... | 01287-4 | Male Fitting, 3/8 NPT x 7-16CC | 43..... | 01229-7 | Tubing - 1/4" ; 124 Series |
| 41..... | 03600-5 | Tubing 7/16" (Manifold to Safety) | 44..... | 28584-6 | Panel, Firebox - S/S (P/N 3524-6 w/ Hinge) |
| 42..... | 01150-9 | Nipple, Pipe - 3/8" NPT x 2 | 44..... | 32657-7 | Panel, Firebox - S/S ; 124 (Includes Hinge) |
| 43..... | 03605-6 | Tubing 1/4" (Manifold to Safety Valve) | 46..... | 32523-6 | Door Trunnion, Rt. - 136XLB |
| 44..... | 28584-6 | Panel, Firebox S/S (Hinged Option) | 46..... | 07628-7 | Door Trunnion, Rt. - 124 Series |
| 45..... | 01260-2 | Spacer, Door Pin | 47..... | 32524-4 | Door Trunnion, Lt. - 136 XLB |
| 46..... | 06077-1 | Door Trunnion - Right | 47..... | 07627-9 | Door Trunnion, Lt. - 124 Series |
| 47..... | 06979-8 | Door Trunnion - Left | 49..... | 11854-0 | Door, Pilot Access - 124 Series & 136XLB |
| 48..... | 03393-6 | Pin, Oven Door - Right & Left | 50..... | 11856-7 | Burner Compartment Front |
| 49..... | 04274-9 | Door, Pilot Access | 51L..... | 14202-6 | Baffle, Air - Left; 124 Series |
| 50..... | 04275-7 | Burner Compartment Front | 51R..... | 14135-6 | Baffle, Air - Right; 124 Series |
| 51L..... | 06346-0 | Baffle, Air - Left | 52..... | 32748-4 | Panel, Right Front - 124 Series |
| 51R..... | 06348-7 | Baffle, Air - Right | 52..... | 34753-1 | Panel, Control - 136XLB |
| 52..... | 34146-0 | Panel, Right Front Control - S/S | 53..... | 32747-6 | Panel, Left Front - 124 Series |
| 53..... | 19780-7 | Panel, Left Front | 53..... | 32388-8 | Panel, Left Front - 136XLB |
| 54..... | 28441-6 | Leg - 6" S/S | 55..... | 11615-7 | Rack, Oven - 124 Series; 25-5/8" x 15-9/16" |
| 55..... | 09005-0 | Rack, Oven - 25-5/8" x 26" | 57..... | 31691-1 | Support, Channel - 124 Series |
| 56..... | 06926-4 | Catch, Spring (female) | | | |
| 57..... | 07584-1 | Channel, Support | | | |

V136 EXPLODED VIEW

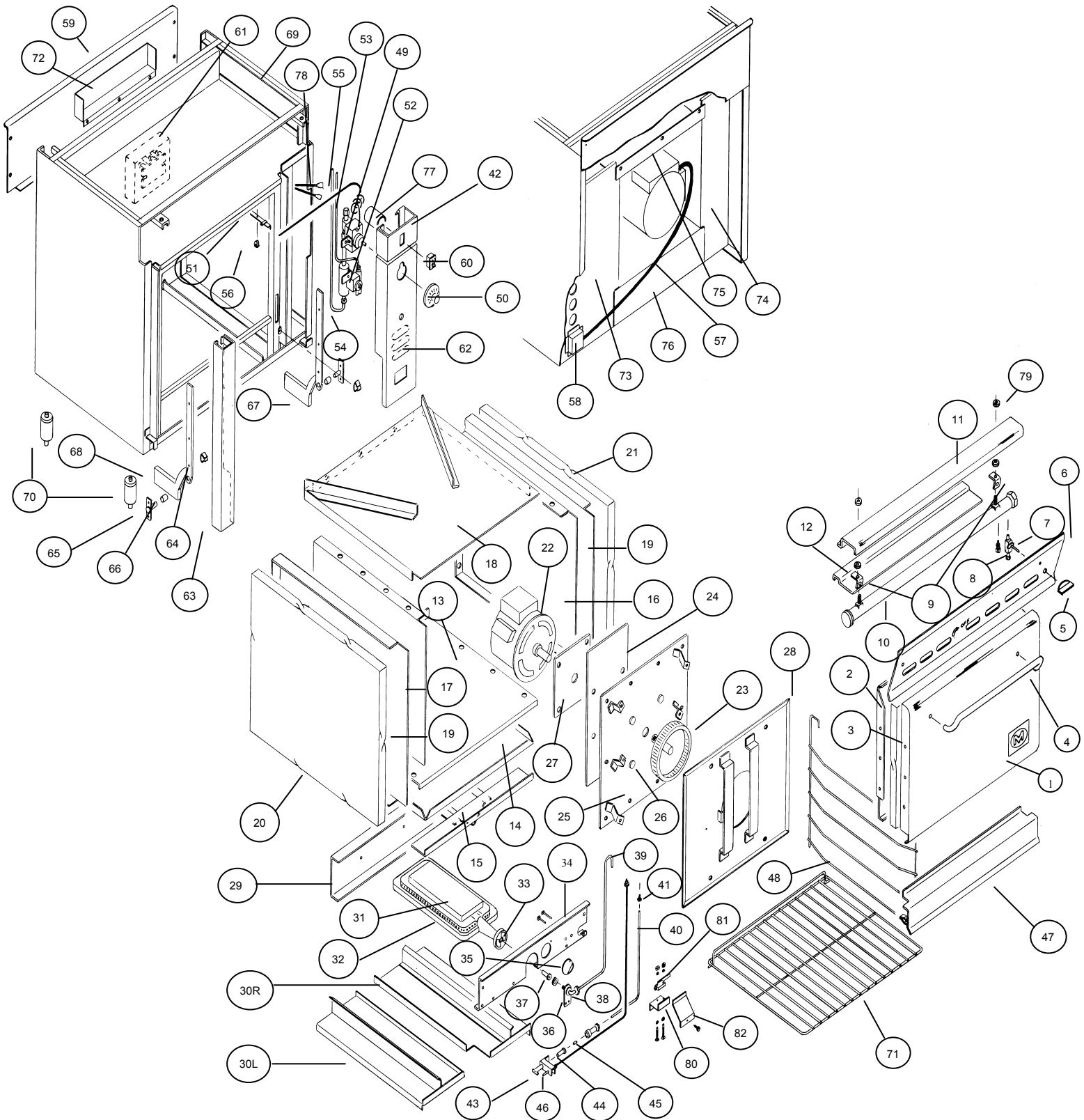

Heavy Duty 136 Series Parts List

Heavy Duty 136 Series Parts List

| Item | Part # | Description |
|----------|---------|---|
| 1..... | 06135-2 | Door Panel, Exterior - S/S |
| 2..... | 11794-3 | Door Liner, Interior |
| 3..... | 01424-9 | Insulation, Door |
| 4..... | 11776-5 | Handle, Door (25 Inches) |
| 5..... | 38485-2 | Handle, Main Oven Valve |
| 6..... | 38286-8 | Valve Panel - 36", S/S |
| 6..... | 38935-8 | Valve Panel - 34" (Frytop) |
| 7..... | 36174-7 | Valve Oven (3/8 NPT x 7/16CC) |
| 8..... | 32739-5 | Connector—Male, 1/8 NPTM x 1/4 CC |
| 9..... | 06137-9 | Bracket |
| 10..... | 36268-9 | Manifold, 36" |
| 11..... | 19773-4 | Guard Rail, 36" S/S |
| 11..... | 19775-0 | Guard Rail, 34" S/S |
| 12..... | 37604-3 | Shield- Drip, Manifold |
| | 37610-8 | Shield- Drip, Manifold RC |
| 13..... | 02426-0 | Liner- Bottom, Oven Interior |
| 14..... | 06138-7 | Baffle—Heat Assembly |
| 15..... | 06139-5 | Baffle- Flame |
| 16..... | 02430-9 | Liner—Side Right, Oven Interior |
| 17..... | 02433-3 | Liner—Side Left, Oven Interior |
| 18..... | 01538-5 | Liner—Top, Oven Interior |
| 19..... | 06140-9 | Liner, Insulation—Left & Right Assembly |
| 20..... | 06141-7 | Insulation, Side—Left |
| 21..... | 06142-5 | Insulation, Side—Right |
| 22..... | 6382-7 | Motor (Baldor) 1/4 HP 115/230V; 1PH; 60CY |
| 23..... | 02123-7 | Blower Wheel |
| 24..... | 6339-8 | Insulation (used w/ 6265-0 & 2167-9) |
| 25..... | 06337-1 | Plate Assembly—Motor Mtg Rear (used w/ 06265-0) |
| 26..... | 01945-3 | Screw, weld 5/16—18 x 1-1/2 |
| 27..... | 06333-9 | Plate, Motor- Spacer (used w/ 06265-0) |
| 28..... | 02431-7 | Baffle—Rear Fan |
| 29..... | 06144-1 | Support—Channel |
| 30L..... | 06346-0 | Baffle—Air, Lt |
| 30R..... | 06348-7 | Baffle— Air, Rt |
| 31..... | 03344-8 | Baffle— Air |
| 32..... | 06349-5 | Burner Assembly (Complete) - Nat. Gas |
| | 06350-9 | Burner Assembly (Complete) - L.P. |
| 33..... | 40560-4 | Air Mixer |
| 34..... | 06147-6 | Front, Burner Compartment |
| 35..... | 6148-4 | Door, Pilot Access |
| 36..... | 2361-2 | Bracket- Orifice Fitting |
| 37..... | 2361-2 | Orifice Hood—Natural (4.0" W.C.) |
| | 06151-4 | Orifice Hood—L.P. (10.0" W.C.) |
| 38..... | 31050-6 | Orifice, Elbow Assembly—Natural (4.0" W.C.) |
| | 06153-0 | Orifice, Elbow Assembly—L.P. (10.0" W.C.) |
| 39..... | 3602-1 | Tubing—Alum. w/ Sleeve; 7/16" OD x 42" |

| Item | Part # | Description |
|---------|---------|---|
| 40..... | 03604-8 | Tubing—Alum. w/ sleeve 1/4" OD x 30" |
| 41..... | 01277-7 | Nut, Threaded Sleeve—1/4 Tubing |
| 42..... | 36493-2 | Panel, Front—RT/Upper—S/S |
| 43..... | 23218-1 | Burner, Pilot Assembly —Natural |
| | 23220-3 | Burner, Pilot L.P. |
| 44..... | 34177-0 | Orifice Hood—Natural |
| | 02191-1 | Orifice Hood—L.P. |
| 45..... | 06155-7 | Nut & Ferrule—1, 4 Tubing |
| 46..... | 1016-2 | Thermocouple 36" |
| | 1013-8 | Thermocouple 30" |
| 47..... | 28584-6 | Panel, Burner Access—S/S |
| 48..... | 02365-5 | Guide—RT/LT, Rack |
| 49..... | 36352-9 | Thermostat w/ Dial—FDTO |
| 50..... | 01977-1 | Dial, Thermostat—FDTO |
| 51..... | 06156-5 | Holder, Sensing Bulb |
| 52..... | 34604-7 | Valve, Safety |
| 53..... | 01287-4 | Connector, Male 3/8 NPTM x 7/16" OD x 23" |
| 54..... | 03600-5 | Tubing—Alum. w/ sleeve 7/16" OD x 23" |
| 55..... | 03605-6 | Tubing—Alum. w/ sleeve 1/4" OD x 14" |
| 56..... | 01942-9 | Clip |
| 57..... | 06157-3 | Conduit—Flex |
| 58..... | 06158-1 | Junction Box Assembly |
| 59..... | 06160-3 | Panel, Back Assembly |
| 60..... | 20318-1 | Switch, Rocker "FAN-OFF-COOL" |
| 61..... | 8584-7 | Block, Terminal |
| 62..... | 36493-2 | Panel, Front—RT/Lower—S/S |
| 63..... | 19780-7 | Panel, Front—Left—S/S |
| 64..... | 06926-4 | Catch, Spring (Female) |
| 65..... | 33579-7 | Pin Assembly, Door RT |
| | 3393-6 | Pin Assembly, Door LT |
| 66..... | 01260-2 | Spacer |
| 67..... | 32869-3 | RT Trunnion |
| 68..... | 06079-8 | Trunnion Assembly- Left |
| 69..... | 06161-1 | Body, Range—Painted |
| 70..... | 28441-6 | Leg w/ Foot—SS—6 in. |
| 71..... | 02364-7 | Rack, Wire |
| 72..... | 06163-8 | Deflector, Flue |
| 73..... | 06164-6 | Panel, Rear—Right Assembly |
| 74..... | 06165-4 | Panel, Rear—Left |
| 75..... | 06166-2 | Panel, Rear—Top Center |
| 76..... | 6167-0 | Panel, Rear—Lower Center |
| 77..... | 6168-9 | Tubing, Heat Shrink |
| 78..... | 6169-7 | Wire Assembly |
| 79..... | 1912-7 | Nut, Hex—Pin |
| 80..... | 33550-9 | Bracket, Door Switch |
| 81..... | 33276-3 | Switch, Door |
| 82..... | 33550-9 | Cover, Door Switch |

VI36: VR26
 WIRING DIAGRAM
 120V: 1PH: 60Hz

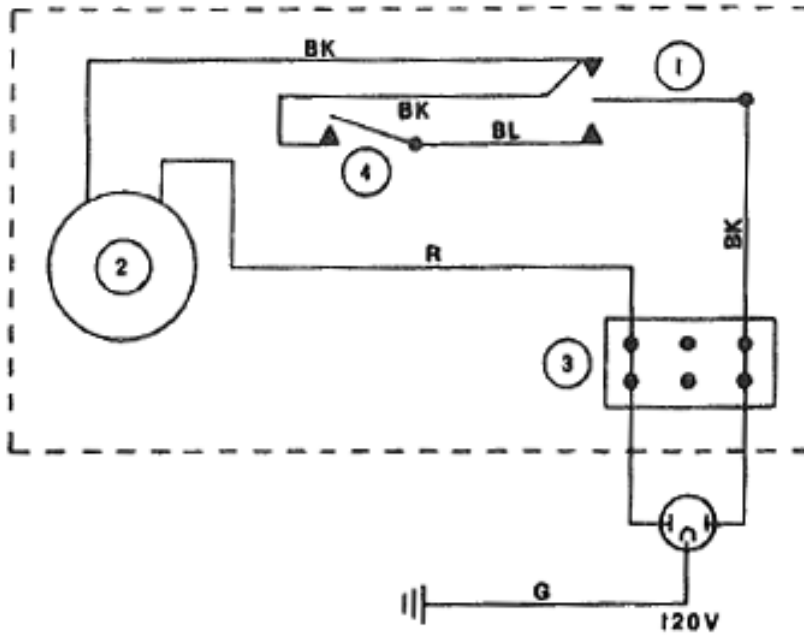

| ITEM | DESCRIPTION |
|------|------------------------|
| 1 | SWITCH, FAN |
| 2 | MOTOR (SPECIFY VOLTAGE |
| 3 | TERMINAL BLOCK { H P } |
| 4 | SWITCH, DOOR |

If any of the original wire, as supplied with the appliance, must be replaced, it must be replaced with the same type or its equivalent.

11663-7

Orifice Size Chart Drill Size

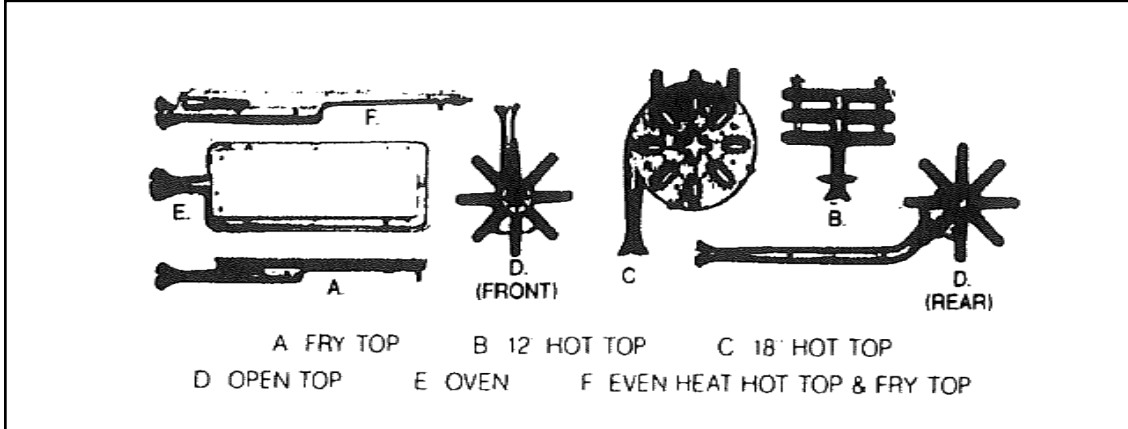

| Type of Burner | A | B | C | D Open Top Front & Rear | D 1/2 Hot Top Front Rear | | E 136 V136 | | F |
|----------------------|----|----|----|-------------------------|--------------------------|----|------------|----|----|
| | | | | | | | | | |
| Natural Gas 4.0" WC | 50 | 46 | 35 | 45 | 45 | 50 | 32 | 31 | 45 |
| Propane Gas 10.0" WC | 56 | 55 | 50 | 55 | 55 | 56 | 49 | 47 | 55 |

WARNING

If not installed, operated and maintained in accordance with the manufacturer's instructions, this product could expose you to substances in fuel or in fuel combustion which can cause death or serious illness and which are known to the State of California to cause cancer, birth defects or other reproductive harm.

The State of California enacted the California Safe Drinking Water and Toxic Enforcement Act of 1986, (Prop. 65), which "prohibits any person in the course of doing business from knowingly and intentionally exposing any individual to a chemical known to the State of California to cause cancer or reproductive toxicity without first giving clear and reasonable warning to such individuals." The Governor's Scientific Advisory Panel added carbon monoxide to the list of hazardous chemicals known to cause reproductive harm.

In order to establish full compliance with Proposition 65, we attached a yellow warning label to each gas fired unit manufactured by the Montague Company.

Carbon monoxide would not be present in concentrations that would pose a "significant risk" to the consumer when the equipment is installed, operated and maintained as follows:

1. Installed in accordance with all local codes, or in the absence of local codes, with the current National Fuel Gas Code Z223.1.
2. Installed under a properly designed and operating exhaust hood.
3. Connected to the type of gas for which the unit is equipped.
4. Proper appliance pressure regulator installed on the gas supply line and adjusted for the manifold pressure marked on the rating plate.
5. Adequate air supply to the unit.
6. The equipment is operated in the manner intended using the proper utensil for that type of appliance.
7. Keep the equipment clean and have it checked periodically.
8. Burner air adjustments, mechanical maintenance and repairs should be performed by qualified service personnel.

If the equipment is not installed, operated and maintained in accordance with the above, concentrations of carbon monoxide in excess of the established limits could present in the kitchen environment.

ALL PERSONNEL IN THE WORKPLACE WHO MAY BE SUBJECT TO ANY EXPOSURE OF CARBON MONOXIDE MUST BE WARNED OF SUCH POSSIBLE EXPOSURE. THIS WARNING SHOULD BE CONVEYED IN A MANNER SO THAT IT IS CLEARLY UNDERSTOOD BY THE EMPLOYEE, AND THE EMPLOYEE SHOULD BE ASKED IF IN FACT HE OR SHE UNDERSTANDS THE CORRECT METHOD OF OPERATION OF THE EQUIPMENT AND THAT A RISK OF EXPOSURE EXISTS IF THE EQUIPMENT IS OPERATED IMPROPERLY.



The MONTAGUE COMPANY
1830 Stearman Avenue, P.O. Box 4954 Hayward, CA 94540-4954

IMPORTANT

When ordering parts, to eliminate mistakes and facilitate delivery, always give the following information:

Serial No. _____

Model No. _____

Change No. _____

Name & No. of Part

Model No. Change No. Serial No.

A diagram illustrating the layout of a part name and number. It consists of a large outer rectangle containing four smaller shapes: three horizontal rectangles and one square. The three rectangles are arranged horizontally from left to right. Lines connect the labels 'Model No.', 'Change No.', and 'Serial No.' (from the line above) to the top-right corners of the three rectangles respectively. The square is positioned to the right of the three rectangles.

The Montague Company
1830 Stearman Avenue
P.O. Box 4954
Hayward, CA 94540-4954

P/N 6171-9