

INSTRUCTION MANUAL

MONTAGUE - **VECTAIRE** HX

Gas Convection Ovens

**MODELS:
HX Series**

**These instructions should be read thoroughly before attempting installation.
Set up and installation should be performed by qualified installation personnel.**

Keep area around appliances free and clear from combustibles.

**PLEASE RETAIN THIS MANUAL
FOR FUTURE REFERENCE.**



THE MONTAGUE COMPANY
1830 Stearman Avenue P.O. BOX 4954
HAYWARD, CA 94540-4954
TEL: 510/785-8822 FAX: 510/785-3342

CONTENTS

INSTALLATION	3
OPERATION	10
COOKING HINTS	15

MAINTENANCE	20
SERVICE	22

IMPORTANT

WARNING:

Improper installation, adjustment, alteration, service or maintenance can cause property damage, injury or death. Read the operating and maintenance instructions thoroughly before installing or servicing this equipment.

FOR YOUR SAFETY:

Do not store or use gasoline or other flammable vapors and liquids in the vicinity of this or any other appliance.

INSTRUCTIONS TO BE FOLLOWED IN THE EVENT THE USER SMELLS GAS MUST BE POSTED IN A PROMINENT LOCATION. THIS INFORMATION MAY BE OBTAINED BY CONSULTING THE LOCAL GAS SUPPLIER.

SHIPPING DAMAGE CLAIM PROCEDURE

For your protection, please note that equipment in this shipment was carefully inspected and packed by skilled personnel before leaving the factory. The transportation company assumes full responsibility for safe delivery upon acceptance of this shipment.

If shipment arrives damaged:

1. **VISIBLE LOSS OR DAMAGE**—Be certain this is noted on freight bill or express receipt, and signed by person making delivery.
2. **FILE CLAIM FOR DAMAGES IMMEDIATELY**—Regardless of the extent of damage.
3. **CONCEALED LOSS OR DAMAGE**—If damage is unnoticed until merchandise is unpacked, notify transportation company or carrier immediately, and file “concealed damage” claim with them. This should be done within fifteen (15) days of date that delivery was made to you. Be sure to retain container for inspection.

We cannot assume responsibility for damage incurred in transit. We will, however, be glad to furnish you with necessary documents to support your claim.

Vectaire gas convection ovens are manufactured for use with the type of gas and electric supply indicated on the nameplate behind the fire box panel.

The Vectaire oven is produced with the best possible material and workmanship.
PROPER INSTALLATION IS ESSENTIAL FOR SAFE AND EFFICIENT TROUBLE-FREE OPERATION.

THE INSTALLATION INSTRUCTIONS CONTAINED HEREIN ARE FOR THE USE OF QUALIFIED INSTALLATION AND SERVICE PERSONNEL ONLY. INSTALLATION OR SERVICE BY OTHER THAN QUALIFIED PERSONNEL MAY RESULT IN DAMAGE TO THE OVEN AND/OR INJURY TO THE OPERATOR.

Qualified installation personnel are individuals, a firm, corporation or company which either in person, or through a representative are engaged in, and are responsible for:

- A. The installation or replacement of gas piping or the connection, installation, repair or servicing of equipment, who is experienced in such work, familiar with all precautions required, and has complied with all requirements of state or local authorities having jurisdiction. Reference: National Fuel Gas Code Z223.1-latest addenda, Section 1.4.
- B. The installation of electrical wiring from the electric meter, main control box or service outlet to the electric appliance. Qualified personnel must be experienced in such work, be familiar with all precautions required and have complied with all requirements of state and local authorities having jurisdiction. Reference: National Electric Code, N.F.P.A. No. 70-latest addenda.

READ CAREFULLY AND FOLLOW THESE INSTRUCTIONS

THE OVEN MUST BE INSTALLED IN ACCORDANCE WITH LOCAL CODES, OR IN THE ABSENCE OF LOCAL CODES, WITH THE NATIONAL FUEL CODE, ANSI Z223.1-LATEST ADDENDA, INCLUDING:

1. The appliance and its individual shutoff valve must be disconnected from the gas supply piping system during any pressure testing of that system at test pressures in excess of 1/2 psig. (3.45kPa).
2. The appliance must be isolated from the gas supply piping system by closing its individual manual shutoff valve during any pressure testing of the gas supply piping system at test pressure equal to or less than 1/2 psig. (3.45kPa).

THIS UNIT WHEN INSTALLED MUST BE ELECTRICALLY GROUNDED IN ACCORDANCE WITH LOCAL CODES, OR IN ABSENCE OF LOCAL CODES, WITH THE NATIONAL ELECTRICAL CODE, ANSI/NFPA No.70-LATEST ADDENDA.

PROVISIONS MUST BE MADE FOR ADEQUATE AIR SUPPLY TO THE UNIT.

INSTALLATION

Ventilating Hood

The ideal method of ventilating a convection oven is the use of a properly designed ventilating hood. The hood should extend at least 6" beyond all sides of the oven. The hood should be connected to an adequate mechanical exhaust system.

Information on the construction and installation of ventilating hoods may be obtained from the "Standard for the Installation of Equipment for the Removal of Smoke and Grease Laden Vapors from Commercial Cooking Equipment", NFPA No. 96– latest addenda, available from the National Fire Protection Association, Batterymarch Park, Quincy, MA 02269.

It is also necessary that sufficient room air ingress be allowed to compensate for the amount of air removed by the ventilating system. Otherwise, a subnormal atmospheric pressure will occur which may interfere with burner performance or may extinguish the pilot flame. In case of unsatisfactory oven performance, check with the exhaust fan in the "OFF" position.

Direct Flue Connection

If the oven is connected directly to an outside flue, a draft hood (P/N 24678-6) must be used. The flue should rise at least 10 feet above the roof or any surrounding structure. The flue must be terminated with an U.L. listed vent cap or spinner.

Clearances

Adequate clearance must be provided in the aisle and at the side and back to allow the doors to open sufficiently to permit the removal of the racks and for serviceability. Adequate clearance for air openings into the combustion chamber must be provided.

A minimum clearance of one inch must be maintained behind the motor. Care must be taken to provide adequate air circulation to prevent the motor from overheating.

<u>CLEARANCES</u>		
MODEL HX-63, HXS-63, HX-55, HXS-55 ENCLOSED BASE & MODULAR STAND:		
	<u>COMBUSTIBLE CONSTRUCTION</u>	<u>NONCOMBUSTIBLE CONSTRUCTION</u>
Back:	7"	7"
Left & Right Side:	6"	0
6" LEGS: SUITABLE FOR INSTALLATION ON COMBUSTIBLE FLOORS.		
MODEL HX2-63, HXS2-63, HX2-55, HXS2-55 SERIES:		
	<u>COMBUSTIBLE CONSTRUCTION</u>	<u>NONCOMBUSTIBLE CONSTRUCTION</u>
Back:	7"	7"
Left & Right Side:	6"	0
6" LEGS: SUITABLE FOR INSTALLATION ON COMBUSTIBLE FLOORS.		
CURB MOUNT WITH 1" TOE BASE (P/N: 6024-0): FOR USE ONLY WITH NONCOMBUSTIBLE FLOORS.		

CAUTION

DO NOT OBSTRUCT THE FLOW OF COMBUSTION AND VENTILATION AIR TO THE OVEN. KEEP THE APPLIANCE AREA FREE AND CLEAR FROM COMBUSTIBLES

Solid state components have a very short life span when exposed to temperatures above 175°F (80° C), therefore, certain installation precautions are necessary. The Vectaire HX oven have been designed to operate below this temperature when properly installed. The following precautions must be observed:

1. Do not obstruct the flow of air through the vent openings at the top of the oven, or the flow of room air to the oven bottom or lower front portion of the burner access panel.
2. Do not mount the oven on a curb unless it has been equipped with the Toe Base (P/N:6024-0) for this type of installation.
3. When stacking ovens, never reverse the top and bottom oven sections.
4. Never stack a solid state controlled Vectaire convection oven, SE or HX series, with a standard Vectaire or another brand of oven without first consulting the factory. Certain ovens are not compatible, or a stacking kit may be required.

SPECIAL CAUTION

DO NOT PLACE HIGH HEAT PRODUCING EQUIPMENT ADJACENT TO THE RIGHT SIDE OF A VECTAIRE HX CONVECTION OVEN. SURFACE TEMPERATURES EXCEEDING 175°F (80°C) CAN CAUSE PREMATURE COMPONENT FAILURE NOT COVERED UNDER MANUFACTURER'S WARRANTY. THE OVENS NEED 6" MINIMUM CLEARANCE ON THE RIGHT SIDE BETWEEN SIMILAR OVEN OR OTHER COOKING EQUIPMENT. OPTIONAL INSTALLATION KITS ARE AVAILABLE TO REDUCE THE MINIMUM CLEARANCE BETWEEN SIMILAR OVENS TO 1" AND BETWEEN OTHER EQUIPMENT TO 2". CONSULT FACTORY.

INSTALLATION

Assembly

Vectaire Models HX-63, HXS-63, HX-55, HXS-55

Attaching Gusset Legs

- Uncrate oven and base as near to final location as possible.
- Remove all packing material and accessories from oven interior.
- With help from at least two people, tip the oven slowly on its side.
- With the oven lying on its side, hold the front leg securely and align the threaded stud on the leg with the nut located at the front corner of the accessible side.
- Insert the leg into the nut and turn the leg clockwise.
- Tighten the leg to the oven securely.
- Rotate the leg counter-clockwise slightly to align the two leg plate holes with the holes in the bottom of the oven.
- Secure the leg using the provided 3/8" bolts and washers.
- Repeat the procedure for the rear corner of the side off the ground.
- Tip the oven up on the secured legs and lean the oven against a wall so that the legs on the remaining side can be attached.
- Install the remaining legs using the above procedure.
- Tip the oven back down on the newly installed legs and re-tighten all the bolts securely.

Caster and Caster Restraint Installation

- The casters are available as an option to the bullet-style feet.
- Tip the oven to its side and lean against a wall.
- Remove the bullet-style feet by prying off with a screwdriver.
- Insert the locking caster into the bottom of the front leg.
- Tighten the knurled lock nut by hand until the caster is secure inside the leg.
- Secure the Caster Restraint Mount to the bottom of the oven directly below the gas inlet pipe. Use the hex head screws supplied.
- Inset the non-locking caster into the rear leg.
- Tighten the knurled lock nut by hand until the caster is secure inside the leg.
- With the casters blocked to prevent movement, tip the oven back down.
- Tip the oven to its other side and lean against the wall.
- Repeat procedure for installing the front and rear casters on the remaining side.
- Once the unit is in place, lock the front casters.
- The restraining means may be attached to the exposed hole in the Caster Restraint Mount.

NOTE

For an appliance equipped with casters, the installation shall be made with a connector that complies with the Standard for Connectors for Movable Gas Appliances, ANSI Z21.69 or Connectors for Movable Gas Appliances, CAN/CGA-6.16, and a quick-disconnect device that complies with the Standard for Quick-Disconnect Devices for use With Gas Fuel, ANSI Z21.41, or Quick Disconnect Device for Use with Gas Fuel, CAN 1-6.9.

Install rack guides inside oven. Place oven on stand. Install flue deflector (P/N:25328-6) or draft hood (P/N:24678-6). Either a flue deflector or a draft hood is shipped with every unit. The flue deflector is intended for use when the oven is installed under a properly designed hood. When the oven is directly connected to the vent system, the draft hood must be used.

When the oven is in permanent position, level entire unit by placing a carpenter's level on the oven rack and adjusting the foot on the bottom of each leg so that the oven is level from front to back and side to side.

Vectaire Models HX-63, HXS-63, HX-55, HXS-55

1. Screw the adjustable feet of the legs in all the way. Then tightly screw the complete leg assembly into the mounting holes at each corner of the lower deck (note logs on top of lower deck). If unit is intended for curb mounting, Tow Base (P/N:6024-0) must be used. The Toe Base is factory installed when curb mount is specified.
2. Set upper deck unit in place on top of lower deck.
3. Install flue riser (P/N:25128-3) over outlet of the horizontal flue collector (P/N: 25135-6) of the lower deck. Secure in place with the screws that are provided. Install flue deflector (P/N:25328-6) over flue outlet of top oven section.
4. Install low profile deflector trim (P/N:26604-3) or draft hood (P/N:24678-6). Either a flue deflector or a draft hood is shipped with every unit. The flue deflector is intended for use when the oven is installed under a properly designed hood. When the oven is directly connected to the vent system, the draft hood must be used.
5. When oven is in permanent position, level entire unit by placing a carpenter's level on the oven rack and adjusting the foot on the bottom of each leg, so that the oven is level from front to back and side to side. Level a curb mounted unit by placing a shim under the low side.

INSTALLATION

Gas Connection

Before connecting oven to the gas supply line, be sure that all new piping has been cleaned and purged to prevent any foreign matter from being carried into the controls by the gas. In some cases, filters or drops are recommended. A separate gas shutoff valve must be installed upstream from the gas pressure regulator adjacent to the oven and be located in an accessible area.

It is important that adequately sized piping be run directly to the point of connection at the oven, with as few elbows and tees as possible. Consult local gas company for proper piping size and gas pressure.

THIS OVEN IS EQUIPPED WITH A COMBINATION GAS VALVE THAT INCLUDED A GAS PRESSURE REGULATOR. NO ADDITIONAL REGULATOR NEEDS TO BE INSTALLED TO THIS UNIT.

For Natural Gas: This pressure regulator is factory adjusted for 3.5" W.C. manifold pressure. The maximum inlet pressure to the regulator should not exceed 10.5" water column.

For Propane Gas: This gas pressure regulator is factory adjusted for 10" W.C. manifold pressure. The maximum inlet pressure to the regulator should not exceed 21" water column.

Connect the gas supply line from the service gas shutoff valve to the inlet side on the unit using 3/4" pipe and a 3/4" to 1/2" reducer. If flexible or semi-flexible connectors are used, an AGA listed flexible connector with an I.D. equal to 3/4" pipe must be used. **DO NOT USE A DOMESTIC APPLIANCE TYPE GAS FLEXIBLE CONNECTOR.** Avoid kinks or sharp bends that could restrict gas flow.

PIPE JOINT COMPOUND OR THREAD SEALANT THAT IS USED SHOULD BE RESISTANT TO ACTION OF LIQUEFIED PETROLEUM GASES.

Turn gas shutoff valve "ON" and immediately check carefully for gas leaks. Do this before

TEST ALL PIPE JOINTS FOR LEAKS BEFORE OPERATING OVEN. THIS INCLUDES ALL GAS CONNECTIONS THAT MAY HAVE LOOSENED DURING SHIPMENT. USE A RICH SOAP SOLUTION (OR OTHER ACCEPTED LEAK TESTER) AROUND ALL PIPE CONNECTIONS AND ALL OTHER JOINTS. DO NOT USE AN OPEN FLAME. ABSOLUTELY NO LEAKAGE SHOULD OCCUR, OTHERWISE THERE IS A DANGER OF FIRE OR EXPLOSION DEPENDING UPON CONDITIONS. NEVER USE IF LEAKAGE IS DETECTED.

Electrical Connection

Unless otherwise specified, the oven is equipped with a 6 foot flexible supply cord for 115 VAC, 60 hertz. A terminal block is provided for 208/240 VAC, 60 hertz, single or three phase units. The wiring diagram is located on the back of the oven.

THIS APPLIANCE, WHEN INSTALLED, MUST BE ELECTRICALLY GROUNDED IN ACCORDANCE WITH LOCAL CODES, OR IN THE ABSENCE OF LOCAL CODES, WITH THE NATIONAL ELECTRICAL CODE, ANSI/NFPA No. 70– LATEST ADDENDA.

1. 115 VAC—60 Hz– Single Phase

Ovens with this electrical rating are factory supplied with a three-wire cord and three-prong plug which fits any standard three-prong grounded receptacle. A separate 15 ampere supply is needed for each oven.

WARNING: ELECTRICAL GROUNDING INSTRUCTIONS
THIS APPLIANCE IS EQUIPPED WITH A THREE PRONG (GROUNDING) PLUG FOR YOUR PROTECTION AGAINST SHOCK HAZARD AND SHOULD BE PLUGGED DIRECTLY INTO A PROPERLY GROUNDED THREE-PRONG RECEPTACLE. DO NOT CUT OR REMOVE THE GROUNDING PRONG FROM THIS PLUG.

2. 115/208-240 VAC—60 Hz—Single Phase (3 Wire)

Ovens with this electrical rating are factory equipped with a 3 pole terminal block. To connect supply wires, remove cover from junction box at right rear of oven. Route supply wires and ground wire through hole with strain relief fitting at bottom of connection box. Attach supply wires to proper terminals of terminal block. Attach ground wire to ground lug inside connection box. See wiring diagram for proper connection.

OPERATION

GAS CONTROL SYSTEM—VECTAIRE HX (all models)

Before lighting, turn on the main gas shutoff valve to the unit and the secondary gas shut off valve located behind the access door on the control panel.

Lighting Instructions—Standard

1. Set thermostat to desired temperature
2. Turn fan control knob to the “HI” or “LO” position. The electronic pilot ignition control will automatically light the pilot and burner each time the thermostat calls for heat.
3. If pilot fails to ignite within 50 seconds, a complete shut down of the ignition system will occur. To initiate re-ignition, turn fan control knob to off position, wait at least 30 seconds, and then turn fan control knob to the “HI” or “LO” position. If three successive shut downs occur, check the entire system for possible causes.

Lighting Instructions— Cook - and - Hold

1. Set the desired cook temperature by turning the “TEMP” set dial clockwise until the correct temperature appears in the upper right hand portion of the display window. A temperature from 150°F to 500°F can be selected in 5°F increments.
2. Turn fan control knob to the “HI” or “LO” position. The electronic pilot ignition control will automatically light the pilot and burner each time the thermostat calls for heat.
3. If pilot fails to ignite within 50 seconds, a complete shut down of the ignition system will occur. To initiate re-ignition, turn fan control knob to “OFF” position, wait at least 30 seconds, and then turn the fan control knob to the “HI” or “LO” position. If three successive shut downs occur, check the entire system for possible causes.

Cool Down

To cool down the oven, quickly turn the fan control knob to “COOL” and open the oven doors. This setting must be used with the doors open to cool down the oven.

Shut Down

Turn fan control knob to the “OFF” position. This shuts off electrical power to the gas valve and control components.

CAUTION

DO NOT ATTEMPT TO LIGHT THE PILOT MANUALLY WITH A MATCH. THIS COULD RESULT IN THE MAIN VALVE BEING ENERGIZED IMMEDIATELY.

Controls**Vectaire HX—Standard Controls (Models with suffix “A”)**

1. “LIGHT-OFF” switch operates interior oven lights when depressed momentarily.
2. The “FAN-CONTROL” knob controls the ignition of the oven as well as the fan operation. It stays on during use to circulate air throughout the oven.
 - a. The top or “12 o’clock” position is “OFF”
 - b. Turning the fan control knob clockwise to the “COOL” setting starts the fan. This setting must be used with the doors open to cool down the oven.
 - c. Turning the fan control knob to the “HI” position operates the fan on high speed, initiating the oven to operate at the temperature set on the thermostat.
 - d. Turning the fan control knob to the “LO” position operates the fan on low speed while initiating the oven to operate at the temperature set on the thermostat.
3. The thermostat controls the oven temperature. The “HEAT” indicator light comes on whenever the burner is lit.
4. The timer is only a time indicator. It has no control over the oven. Turn clockwise to the desired cook time. When completed, an alarm will sound. Turn the dial counter-clockwise to the off position to cancel the alarm.

Vectaire HX—Cook - n - Hold Controls (Models with suffix “AH”)

1. “LIGHT-OFF” switch operates interior oven lights when depressed momentarily.
2. The “FAN-CONTROL” knob controls the ignition of the oven as well as the fan operation. It stays on during use to circulate air throughout the heat exchanger.
 - a. The top or “12 o’clock” position is “OFF”
 - b. Turning the fan control knob clockwise to the “COOL” setting starts the fan. This setting must be used with the doors open to cool down the oven.
 - c. Turning the fan control knob to the “HI” position operates the fan on high speed, initiating the oven to operate at the temperature set on the thermostat.
 - d. Turning the fan control knob to the “LO” position operates the fan on low speed while initiating the oven to operate at the temperature set on the thermostat.

OPERATION

3. Using the Timer.

- a. Rotating the “TIMER” dial at any time will put the electronic control into the Timer set mode. Clockwise rotation will increase the Timer set value while counterclockwise rotation will decrease the Timer set value.
- b. Pressing the “START TIMER” switch causes the control to begin countdown. When the Timer reaches zero, an audible alarm shall sound to indicate completion. The audible alarm is canceled by pressing any key, or turning either rotary switch. The Timer can be reset to zero at any time by pressing the “CANCEL TIMER” button.

4. Temperature control.

- a. Rotating the “TEMP” dial clockwise will increase the temperature while counterclockwise rotation will decrease the set temperature. The set temperature will change by 5°F increments. If the set temperature is at zero, the control is in non-cook mode. Entering a set temperature causes the control to immediately enter a cook mode and regulate temperature.
- b. The control will flash the temperature digits to indicate to the user that the oven is in a preheat stage. The temperature digits will become static once the oven crosses the set point.
- c. The control has a preset hold temperature for the oven to switch to once the timer counts down to zero. The control will display “HOLD” in the timer digits, and the Hold Set Temperature in the Temperature digits. This option can be changed by the user: The procedure to enter a Hold Set Temperature is to set the “Timer” to 00:00 and adjust the temperature so it displays a “50” in the right two digits, then press and hold the “START TIMER” and “CANCEL TIMER” keys simultaneously for 5 seconds. To indicate the control has entered the Hold Set mode, the control will display “HOLD” in the timer digits and the Hold Set Temperature in the Temperature digits. Turning either the Timer or Temperature dial will modify the Hold Set Temperature. To exit the Hold set mode, press the “CANCEL TIMER” key. If the Hold Set Temperature is adjusted to “000”, the Hold Mode is disabled.

NOTE: In the event of a prolonged power failure, no attempt should be made to operate the unit until power is restored.

Vectaire HX—Intermittent Fan Control (IFO) Control (Optional)

The IFO fan control cycles the fan ON for 30 seconds and OFF for 30 seconds during a variable time of 0 to 10 minutes of the cook period. Since the burner and the fan are linked, the burner will shut off when the fan is off, and will be reignited by the electronic ignition spark when the fan cycles back on.

1. **START SWITCH (MOMENTARY)**
Activates the IFO cycle.
2. **CYCLE TIMER (0 TO 10 MIN.)**
Controls the duration of the IFO cycle.
3. **INDICATOR LIGHT (AMBER)**
When lighted, indicates oven is in the IFO cycle.

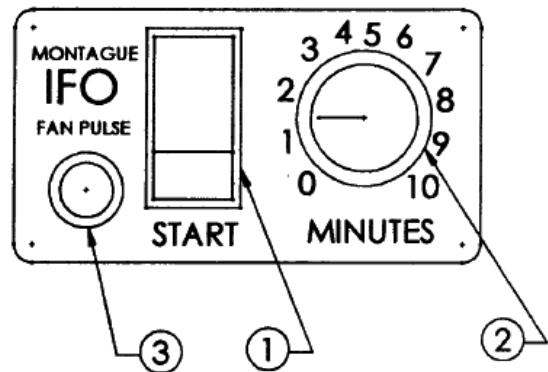

IFO Operation

To set the IFO controls, first set the “Cycle Timer” knob for the desired IFO time period. Once the oven has reached temperature, load the product to be baked and close the door. Immediately set and start the standard timer for the overall cook cycle. Next, push the “Start” switch on the IFO control. The amber indicator light will come on, the fan will stop, and then cycle on and off every 30 seconds until the set time has expired. The amber light will remain on continuously until the set time has expired.

Once the amber light is on, additional pushing of the “Start” switch will have no effect. Also the “Cycle Timer” knob does not count down during the IFO cycle, but remains at its setting for a repeat cycle if desired.

To cancel the IFO cycle once started, simply rotate the “Cycle Timer” knob counterclockwise until it stops.

Once started, the IFO time period can be readjusted by simply repositioning the “Cycle Timer” knob. If the knob is turned counterclockwise to a setting that is less than the current time expired during the cycle, the cycle will be terminated. To restart a cycle, simply push the “Start” switch.

If it is necessary to open the door during the IFO cycle, the fan will shut off if it is running. The IFO timed cycle will continue uninterrupted, however, until the set time has expired. If there is a loss of power during the cycle, it will be terminated.

Depending on the baking product and the load, it may be desirable to pre-heat the oven 50° higher than the desired set temperature when using the IFO control.

OPERATION

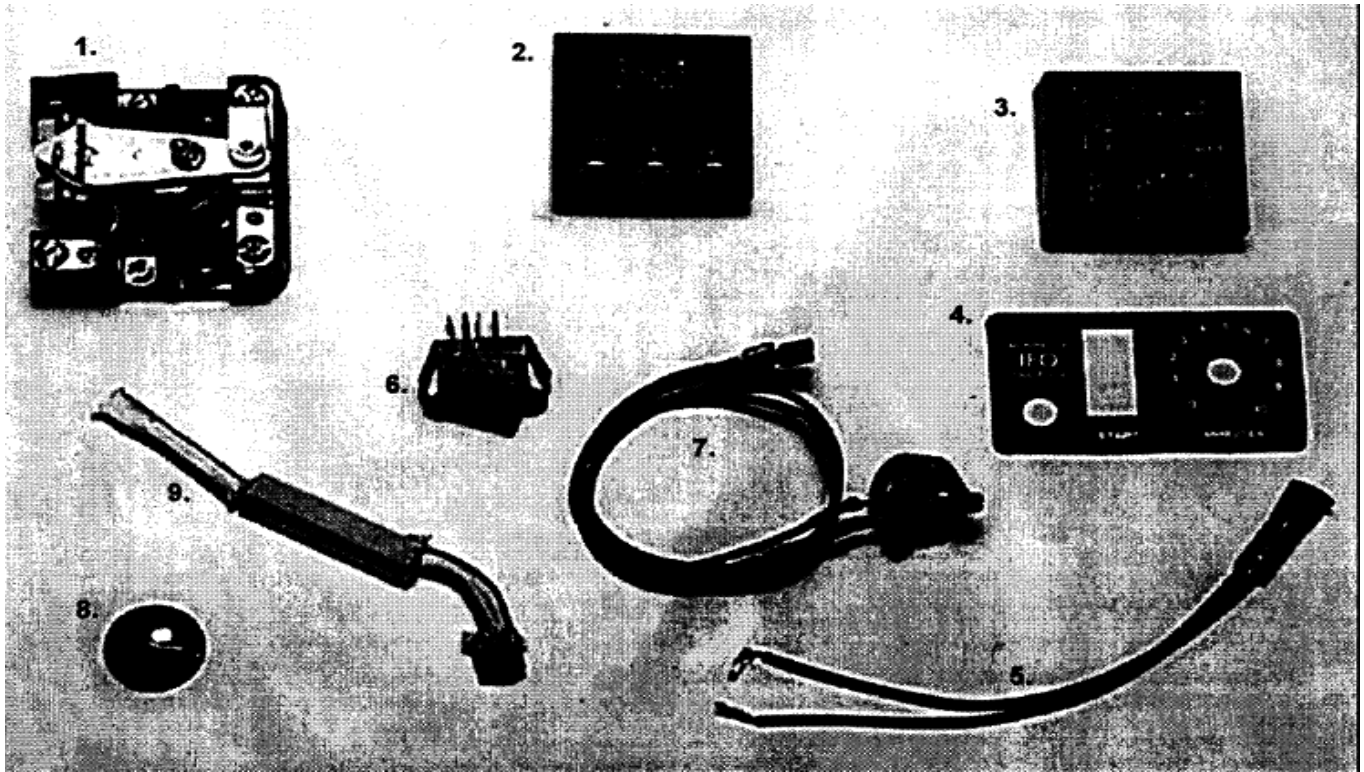

1. RELAY

- A. 02332-9 SPDT; 120VAC; 30 AMP; 1 HP
- B. 17953-1 SPDT; 208VAC; 25 AMP; 1 HP
- C. 17955-8 SPDT; 240VAC; 25 AMP; 1 HP

2. RECYCLER, ON/OFF

- A. 17950-7 IFO CONTROL- 230V
- B. 17951-5 IFO CONTROL- 120 V

3. TIMER, SOLID STATE

- A. 17948-5 IFO CONTROL-120V
- B. 17949-3 IFO CONTROL-230V

4. OVERLAY, CONTROL - IFO

- A. 17653-2 VECTAIRE CONVECTION OVENS
- B. 29625-2 VECTAIRE HX SERIES

5. LIGHT, CYCLE INDICATOR

- A. 17945-0 125V; AMBER .375 DIA
- B. 17946-9 250V; AMBER .375

6. SWITCH, ROCKER

- 17947-7 SPST BLK "MOMENTARY"

7. POTENTIOMETER

- 17952-3 IFO CONTROL

8. KNOB, CONTROL

- 17956-6 IFO CONTROL; TIMER

9. RESISTOR ASSEMBLY

- 18138-2 IFO COMPONENT

USING A VECTAIRE HX

The **VECTAIRE HX** is a different type of oven which offers many features and advantages to the food service operation. The operation of the oven is not difficult to understand or control.

The **VECTAIRE HX** is the sealed type of oven where the combustion products are separated from the air inside the oven. The heat is transferred by continuously drawing air through a heat exchanger suspended over the heat source and into the oven interior. The air inside the oven is constantly recirculated over the product while mixing air from the heat exchanger as well.

The moving air strips away the insulating layer of still air and moisture on the products, allowing heat to penetrate faster for quicker baking and roasting. Due to these differences in the methods of cooking in a convection oven, procedures and techniques may require some modification for successful results. A general rule which will assist in better operation, is cooking time will be less and temperatures should be 25 to 75 degrees lower than those called for in standard recipes.

For convection oven cooking, reduce temperature 25 to 75 degrees from those given in standard recipes.

<u>Type of Food</u>	<u>Reduction in Temperature</u>	<u>Reduction in Time</u>
Baked Products		
Cookies	25°	1/4 to 1/3
Cakes & Quick Bread	50°	1/4 to 1/3
Yeast Products	75°	1/4 to 1/3
Casseroles	25°	1/4 to 1/2

GUIDE TO BAKING TIMES AND TEMPERATURES

These times and temperatures were especially prepared and tested for use in a **Vectaire** convection oven. Times, temperatures, and moisture contents may vary in other convection ovens. The suggested times and temperatures may vary considerably from those shown. They are affected by weight of load, recipe, type of pan, size of portion, and calibration of thermostat. Differences in quality and age of meats and fowl, and quantities of shortening, milk, fat, and other ingredients in baked goods affect both cooking times and temperatures.

These charts have been compiled carefully. However, they are only guides. You may want to cook certain foods a little more or a little less according to your preference and your recipe. Also, types and sizes of pans influence baking time and temperatures.

It is absolutely necessary to use lower temperatures. As a guide, set oven temperatures 25-75 degrees lower than called for in your recipes using non-convection ovens.

Use this chart as a guide to develop your own cooking techniques.

COOKING HINTS

Guide to Time and Temperature

<i>Product</i>	<i>Temperatures (Degrees F)</i>	<i>Time</i>	<i>Number of Racks Used</i>
<i>Bread, Bakery</i>			
Bread (24-1lb. loaves)	340	30 min.	3
Hamburger Rolls	300	15 min.	5
Corn Bread (Northern)	335	25 min.	5
Corn Bread (Southern)	375	15-20 min.	5
Yeast Rolls	325	25 min.	5
Baking Soda Biscuits	400	6 min.	5
Cinnamon Buns	335	20 min.	5
Danish	335	12 min.	5
Brownies	300	18 min.	5
Cream Puffs	350	20-25 min.	5
Sugar Cookies	300	15 min.	5
Chocolate Chip Cookies	275	8-10 min.	4
Sheet Cakes (5lb./1" pans)	325	16-18 min.	5
Chocolate Cake	325	20 min.	5
Angel Food Cake	250	25-30 min.	3
Fruit Cakes	275	70 min.	3
Pie Shells	350	12 min.	5
Frozen Berry Pies (20 oz.)	350	35 min.	5 (30 Pies)
Frozen Berry Pies (46 oz.)	350	45-50 min.	5 (20 Pies)
Fruit Cobbler	375	25 min.	5
Fresh Apple Pies (20 oz.)	350	25-30 min.	5 (30 Pies)
Pumpkin Pies	275	30-35 min.	5
Custard Pies	250	25-30 min.	5
Meringue Pies	350	4 min.	5
Apple Turnovers	350	20 min.	5
Fruit Crisp	300	25 min.	5
Pizza (13")	475	6 min.	5
<i>Meat, Poultry, Fish</i>			
Hamburger Patties	400	8 min.	9
Meat Loaf	325	40-45 min.	3
Prime Rib (20 lbs.)	250	2-1/2 hrs.	2
Rolled Beef Roast (12-15 lbs.)	250	2-1/2 hrs.	3
Steamship Round (80 lbs.)	275	2-3/4 hrs.	2
Steaks - New York	450	7 min.	5
Steaks - Salisbury	300	20 min.	5
Boned Veal Roast (15 lbs.)	300	3 hrs.	2
Stuffed Pork Chops	375	25-30 min.	5
Lamb Chops (Sm. Loin)	400	6 min.	5
Fish Sticks	335	16-18 min.	9
Halibut Steaks (Frozen)	350	20 min.	5
Lobster Tails (Frozen)	425	7 min.	5
Stuffed Lobster	400	6-7 min.	3
Stuffed Shrimp	400	6-7 min.	5
Chicken Breast & Thigh	325	40 min.	5
Chicken (2-1/2 lbs. Quartered)	325	30 min.	5
Turkey, Rolled (18 lbs.)	310	3-1/2 hrs.	3
Chicken - Turkey Pot Pies	400	30-35 min.	5
<i>Miscellaneous</i>			
Idaho Potatoes (120 ct.)	400	50 min.	5
Lasagna	250	90 min.	3
Stuffed Peppers	350	15-20 min.	3
Hot Dogs	300	10-15 min.	5
Melted Cheese Sandwiches	400	8 min.	9
Macaroni and Cheese	350	15-20 min.	5

Suggestions

- Avoid recipes that would not be satisfactory in a regular conventional oven.
- Times and temperatures will vary slightly with maximum to minimum oven loads.
- Stagger pans in ovens as much as possible to allow the free flow of air.
- Pans may be tightly sealed with sheets of aluminum foil. Do not let foil touch the food.
- Convection ovens usually save 1/4 to 1/3 of the total cooking time. Check product at one-half of the cooking time of the recipe. Add additional time as needed.
- For most products, use a maximum of 5 racks for optimum results.
- For less browning, lower temperature; for more browning, increase temperature. If product cooks too quickly around the edges, lower temperature.
- Level pans bake more evenly than warped pans.
- Filling pans too full causes uneven baking.
- When using frozen entrees, refrigerator-thaw for best results, and cover during cooking.
- Load and unload food quickly. Close oven doors promptly.
- The type of pans used affect baking time and results. A light shiny pan reflects heat, a dark dull pan absorbs heat.
- When baking fruit pies, use a baking pan on the rack and set pie tins on top of pan. This will result in evenly cooked bottoms and also catch spillovers.

Baking Difficulties & Problem Causes

Good baking is a delicate operation and many operational factors enter into it.

Pans which warp or buckle under heat always result in poor bakes. Pans with highly polished reflecting surfaces generally cause light colored bottoms and sides. Muffin tin cups should all rest on a flat surface, otherwise light or underdone bottoms will result. Pie tins that are pocked or warped will give undesirable results.

Overproofing, working of dough in too high of a room temperature, overworking pastry dough, absence of or improper scaling, cutting, and uneven loading of pans are sure ways of getting uneven baking.

COOKING HINTS

"HIT OR MISS" recipe mixing: Guess work in the matter of quality and quantity of ingredients frequently results in poor bakes.

The following are some baking problems and their probable causes:

Goods Pulled to Rear of Oven

- Oven not level. Pitched to rear causes dough to run to rear.
- Pans too full. Excess will pull over back toward fan.
- Batter has too high a percentage of liquid.

Uneven Bakes

- Insufficient heat input.
- Warped pans.
- Warped oven racks.
- Uneven loading of pan or pans.
- Fan off.
- Oven not level causing dough to run to side or rear of pan.

Spotty Pie Bottoms/Bread

- Overworked pastry/dough.

Burned Goods, Cripples

- Incorrect temperature.
- Thermostat out of calibration.
- Left in too long.
- Improper scaling.

Dried Out Goods

- Too low temperature.
- In oven too long.
- Improper mix.

Alternately Good and Poor Results

- Fan off and on.
- Improper scaling and control of ingredients.

Tops Dark, Center Not Done

- Too high temperature

Side Burning

- Oven not level.
- Uneven loading.

Lack of Uniformity—Same Pan

- Uneven loading in pan. (See uneven bakes).
- Faulty pans.

Lack of Spring

- Overproofing.
- Incorrect temperature.

Cracked Cakes

- Too high temperature
- Too fast cooling.

Underdone Pie Bottoms (Advisable to bake on cookie sheet)

- Pastry too rich.
- Pastry too thick.
- Warped pie tins. (When used on cookie sheet)

Heavily Colored Pie Rims

- Air bubbles enclosed in pastry when crimped.

Uneven Baked Cookies

- Not scaled properly.
- Pans warped.

LIQUID BATTERS OR FLUID PRODUCTS

THE FAN INTAKE OR DISCHARGE AIR CAN BE DISRUPTIVE TO LIQUID BATTERS THAT CAN BE PULLED OR BAKED PRODUCTS WITH EXCESS LIQUIDS. IT IS RECOMMENDED THAT THESE PRODUCTS BE BAKED ON THE LOW FAN SETTING AND LOADED SO THAT THE BAKING PAN IS NOT PUSHED UP AGAINST THE REAR FAN BAFFLE. SHEET PANS SHOULD NORMALLY BE LOADED IN THE WIDE DIMENSION, ALTHOUGH ALTERNATING LENGTHWISE AND WIDTHWISE LOADING ON THE RACKS CAN PRODUCE GOOD RESULTS WITH CERTAIN TYPES OF PRODUCTS.

MAINTENANCE

CAUTION

DISCONNECT POWER BEFORE CLEANING OR SERVICING. EACH OVEN SECTION HAS A SEPARATE ELECTRICAL SUPPLY CONNECTION.

NOTE

IF THE UNIT IS SUPPLIED ON CASTERS, IT IS RESTRAINED AT THE CASTER RESTRAINT MOUNTS. IF DISONNECTION OF THE RESTRAINT IS NECESSARY, INSURE THAT THE RESTRAINT IS RECONNECTED AFTER THE UNITS HAS BEEN RETURNED TO ITS ORIGINALLY INSTALLED POSITION.

General Cleaning

The complete oven should be given a periodic cleaning. Lint and grease suspended in the air tend to collect in air passages.

Remove burner compartments access panel and clean any dirt and lint from burner primary air opening and all air passages and openings. Clean lint and grease accumulation from motor air openings.

Exterior

PAINTED SURFACE: Allow equipment to cool after use and wash with a mild detergent or soap solution. Dry thoroughly with a dry cloth.

STAINLESS STEEL SURFACES: Follow instructions in Stainless Steel section.

Oven Interior

STANDARD FINISH (Porcelain Enamel): Frequent cleaning is required. Spillovers should be cleaned as soon as possible to prevent carbonizing and a burnt-on condition. Wait until oven is cool for complete cleaning. Usually a soap or detergent solution is strong enough to remove any grease residue. A mild abrasive nylon cleaning pad may be used for stubborn spillovers or stains. Non-caustic commercial oven cleaners may be used, but do not allow cleaners to come in contact with the temperature probe. Wipe off all oven cleaner residue.

The racks and rack guides are readily removable for cleaning. Loosen retainer clips to disengage rack guides for removal.

Foreign matter may collect on the fan blades and reduce circulation. When this becomes apparent, remove the fan baffle plate which is secured by 4 thumb screws and pull plate up and forward. The use a stiff brush on each fan blade.

STAINLESS STEEL: To remove normal dirt, grease, or product residue from stainless steel, use ordinary soap and water (with or without detergent) applied with a sponge or cloth. Dry thoroughly with a clean cloth.

To remove grease and food splatter, or condensed vapors that have baked on the equipment, apply cleanser to a damp cloth or sponge and rub cleanser on the metal in the direction of the polish lines of metal. Rubbing cleanser as gently as possible in the direction of the polished lines will not mar the finish of the stainless steel. NEVER RUB WITH A CIRCULAR MOTION. Soil and burnt deposits which do not respond to the above procedures can usually be removed by rubbing the surface with SCOTCH-BRITE scouring pads or STAINLESS scouring pads. DO NOT USE ORDINARY STEEL WOOL as any particles left on the surface will rust and further spoil the appearance of the finish. NEVER USE A WIRE BRUSH, STEEL SCOURING PADS (EXCEPT STAINLESS), SCRAPER, FILE OR OTHER STEEL TOOLS. Surfaces which are marred collect dirt more rapidly and become more difficult to clean. Marring also increases the possibility of corrosion attacking the surface.

TO REMOVE HEAT TINT: Darkened areas sometimes appear on stainless steel surfaces where the area has been subjected to high heat. These darkened areas are caused by thickening of the protective surface of the stainless steel and are not harmful. Heat tint can normally be removed by the foregoing, but tint which does not respond to this procedure calls for a vigorous scouring in the Direction of the Polish Lines, using SCOTCH-BRITE scouring pads or a STAINLESS scouring pad in combination with a powdered cleanser. Heat tint action may be lessened by not applying or by reducing heat to equipment during slack period.

Electric Fan Motor

The customized electric fan motor has been specially manufactured for convection oven application and should, under normal conditions, give years of trouble-free service.

The unit is supplied with permanently lubricated sealed bearings which require no additional lubrication. A high temperature grease has also been used to increase bearing life and should only be replaced by a qualified servicer.

The motor is equipped with a built thermal overload protector which will warn of any overheating.

The motor is an open drip-proof type and care should be given to see that the ventilation openings remain clear.

If problems do develop with the motor, contact your nearest authorized service situation, and do not attempt repairs yourself. This is a special piece of equipment and should only be serviced by persons familiar with the construction.

CAUTION:

CARE SHOULD BE USED WHEN WASHING DOWN EQUIPMENT TO KEEP WATER AND CLEANING SOLUTIONS OUT OF THE MOTOR, OR DAMAGE WILL OCCUR

SERVICE

WHEN SERVICE IS NEEDED, CONTACT A LOCAL SERVICE COMPANY, DEALER, OR FACTORY TO PERFORM MECHANICAL MAINTENANCE AND REPAIRS. THESE INSTRUCTIONS ARE INTENDED FOR USE BY COMPETENT SERVICE PERSONNEL ONLY.

CAUTION:
DISCONNECT POWER BEFORE DOING ANY SERVICE WORK. EACH OVEN SECTION HAS A SEPARATE ELECTRICAL SUPPLY CONNECTION. TURN OFF GAS SUPPLY WHEN SERVICING GAS CONTROL SYSTEM.

Main Burner

The orifice on the manifold is the fixed type, sized for the respective gas supply.

Door Adjustment

Procedure:

1. Right hand door on oven does not close when left hand door closes. Loosen turnbuckle "1" and tighten turnbuckle "2".
2. Left hand door on oven does not close when right hand door closes. Loosen turnbuckle "2" and tighten turnbuckle "1".

Note: Half turn on turnbuckle equals approximately 1/2" adjustment. When through with adjustment both turnbuckles should be left flat so as to clear front fire box panel.

Thermostats Calibration

The calibration of the thermostat should not be changed until sufficient experience with cooking results has definitely proved that the thermostat is not maintaining proper oven temperature. Before any recalibration is attempted, the oven temperature should be checked using a good grade thermometer.

Calibration Verification

1. Place a thermometer thermocouple or a reliable mercury oven type thermometer and the center of the middle rack.
2. Turn the dial of the cook thermostat to a temperature setting of 350°F.
3. The red heat indicator light will switch off when the thermostat turns off the burner.
4. Allow three (3) burner on/off cycles for the temperature to stabilize.
5. Read the pyrometer or thermometer immediately after the “HEAT” light does off for the third time and again immediately after the “HEAT” light comes on the next time.
6. If the average readings and the dial setting vary by more than 15°F recalibrate by following the instructions outlined below.

Recalibration—Vectaire HX w/ suffix “A”

WHEN RECALIBRATION IS NEEDED, CONTACT A LOCAL SERVICE COMPANY, DEALER, OR FACTORY TO PERFORM MECHANICAL MAINTENANCE AND REPAIRS.

Recalibration—Vectaire HX w/ suffix “AH”

The temperature controller uses solid state components and **NEVER** needs calibration as long as the control is operating properly.

SERVICE

Control Error Codes—Vectaire HX w/ suffix “AH”

Error codes are provided to aid in determining the nature of common oven failures, and to inform the user of safety or performance problems. Each error has an associated code number that is displayed in the time digits when the error occurs. Except for the missing 50/60 Hertz error, the control also sounds a series of attention tones. In the event these errors are activated the control must be powered down to clear the failure mode.

The following error codes indicate a problem with the temperature probe. (Either open circuit or short circuit.) If other codes are displayed, please contact a local service company or dealer to perform maintenance.

F3 – Code

The control has detected that the oven temperature sensor has an open circuit condition while the control is in cook mode. The condition must exist for a period of 16 temperature conversions to the alarm code. When the control detects this error code it will cancel all outputs before the alarm sounds.

F4 – Code

The control has detected that the oven temperature sensor has a short circuit condition while the control is in cook mode. The condition must exist for a period of 16 temperature conversions to sound the alarm code. When the control detects this error code, it will cancel all outputs before the alarm sounds.

Replacement Of Oven Interior Light Bulbs

- 1. Disconnect electrical power to oven before servicing.**
2. Remove oven racks and rack guides by lifting out of holder and pulling out from oven.
3. Remove four screws holding the fan baffle and pull the panel up off the heat exchanger exit and pull the panel forward to expose the light sockets.
4. Unscrew the light cover from the socket, exposing the bulb.
5. Unscrew the bulb and replace.
6. Assemble by reversing the above procedure.

Removal of Main Burner and Pilot Burner Assembly

1. **Disconnect electrical power to oven before servicing.**
2. Remove burner box panel access.
3. Turn off gas supply to oven.
4. Disconnect gas inlet fitting from right side of the front manifold.
5. Remove the two (2) screws securing the manifold to the frame.
6. Remove the manifold.
7. Disconnect the sensor probe cable from the probe.
8. Disconnect the spark wire lead from the G770 Electronic Ignition Control.
9. Disconnect the pilot burner tube from the pilot burner.
10. Slide the main burner and pilot burner assembly off the locating stud on the rear burner support and out of the burner compartment.
11. Installation is the reverse of the above procedure. (Ensure the hole at the rear of the burner assembly has mated with the locating stud on the rear mount before assembling.)

Removal of Combination Gas Valve

1. **Disconnect electrical power to oven before servicing.**
2. Turn off gas supply to the oven.
3. Remove burner box access panel.
4. Remove screw located under the handle at the top of the control panel.
5. Pull control panel down and slide off bottom hinge if necessary.
6. Disconnect pilot burner tubing from the right side of the valve.
7. Disconnect brass tube fitting located at the bottom of the gas control valve after pipe show.
8. Holding the Combination Gas Valve, disconnect union at top of valve.
9. Remove four quick connects located behind valve.
10. Remove valve from oven.
11. Remove pipe elbows if replacing unit and switch to new unit.
12. Installation is reverse of removal.

Pilot Service

- If pilot flame burns yellow, clean pilot orifice and pilot burner to insure a steady blue flame. The orifice can be cleaned by washing in a solvent and/or blowing out with air.
- Flame must surround the flame sensor probe tip for approximately 1/2 inch.

Electrical Component Removal

1. **Disconnect electrical power to oven before servicing.**
2. Turn off gas supply to the oven.
3. Remove burner box access panel.
4. Remove screw located under the handle at the top of the control panel.
5. Remove electrical components and test as necessary.

SERVICE

Removal of Motor and Fan Assembly

1. **Disconnect Electrical Power to Oven(s) Before Servicing**
2. Remove oven racks and rack guides by lifting out of holder and pulling out from oven.
3. Remove four screws holding the fan baffle and pull the panel up off the heat exchanger exit, and pull the panel forward to expose the fan.
4. Remove the ten (10) 1/4" bolts holding Motor Mount Plate in back of oven.
5. Pull plate forward 1 -1/4" to 1-1/2" so that the motor flange clears 10" cut out in back of oven. Then let motor drop and rest on frame. (The first time this is done, the 1/4" thick rectangular insulation pad between motor and oven back will have to be forced to fit through the round 10" hole.) Pull motor through hole and rest oven on bottom. Reach behind plate and remove top of electrical box mounted on motor. Mark or identify wires for reconnection. Disconnect wire and remove flex from motor. Motor, panel and fan may then be removed from oven.
6. Remove two Allen screws from hub and pull off fan using wheel puller. A flange on hub is provided so a wheel puller can be used.
7. Remove four hold-down nuts at motor mounting and remove motor.
8. **IMPORTANT:** when reinstalling motor, check alignment so that fan will not come into contact with plate or fan baffle. Check wiring for proper voltage connection. Always use a new insulation pad to insure against hot air leaks around the motor.

Operation Difficulties and Probable Causes

Fan Shuts Off, Light Still Works

- Door open.
- Door switch needs adjusting.
- Motor overheating from lack of air circulation. Comes on when motor is cool.
- Loose connection.
- Fan or door switch defective.

Fan Will Not Shut Off When Door Is Open (when not in cool mode)

- Door switch needs adjusting or defective.
- Fan switch is in "Cool" position.
- Fan switch is defective.

Fan and Light Off

- Electrical power supply turned off.
- Plug disconnected.

Oven Controls Overheating

- Holes in top panel covered.
- Range installed on control side conducting heat to control compartment. (Contact factory.)
- Oven setting on curb without 1" toe base or legs.
- Poor draft in flue. Heat coming out from burner compartment and pulled up into control compartment instead of going out rear flue opening.
- Door seal leaking.
- Kitchen exhaust hood not operating properly.

Poor Heat Distribution - Hot Spots (See Baking Difficulties)

- Too low gas input.
- Thermostat out of calibration.
- Fan not on.
- Too much or too little draft in flue.
- Poor seal across center of door.
- Baffle too far from fan.
- Foreign matter or obstruction in fan wheel or back of baffle.
- Thermostat set too high.

Oven Takes a Long time and/or Will Not Reach Temperature

- Oven out of calibration.
- Gas pressure too low.

Door Stocks or Not Closing Properly

- Check adjustment.

SERVICE

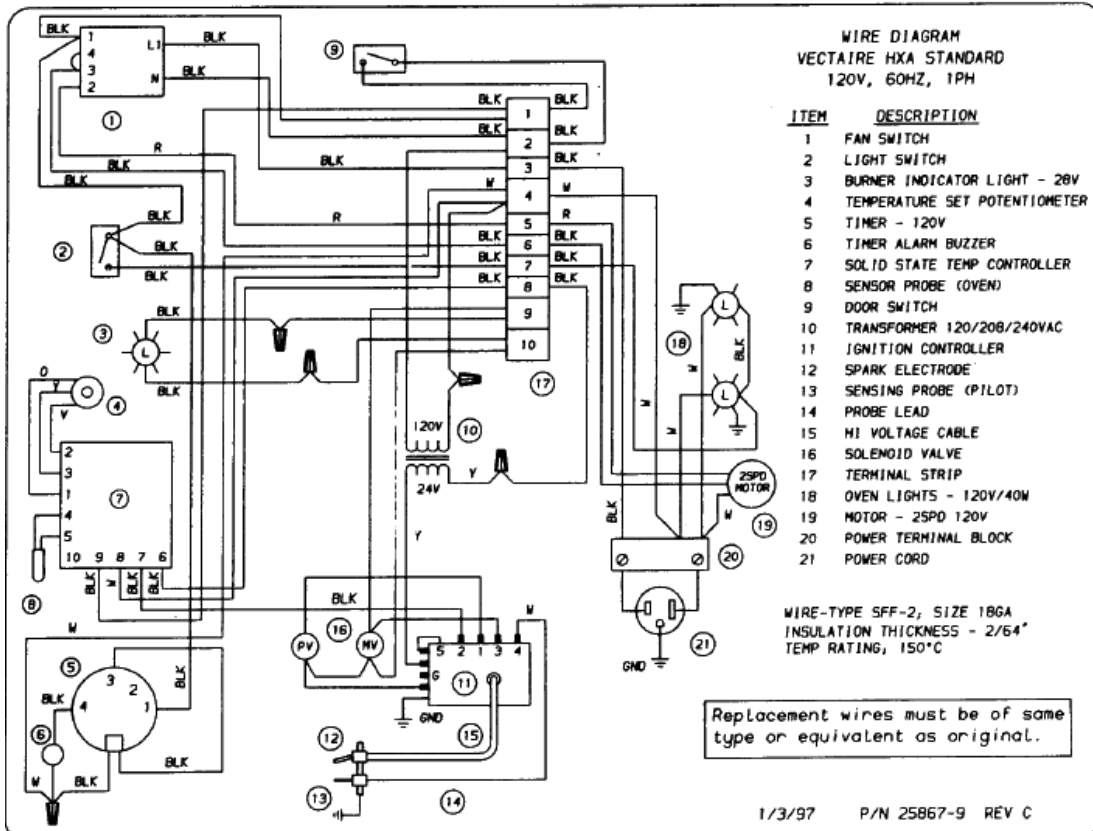
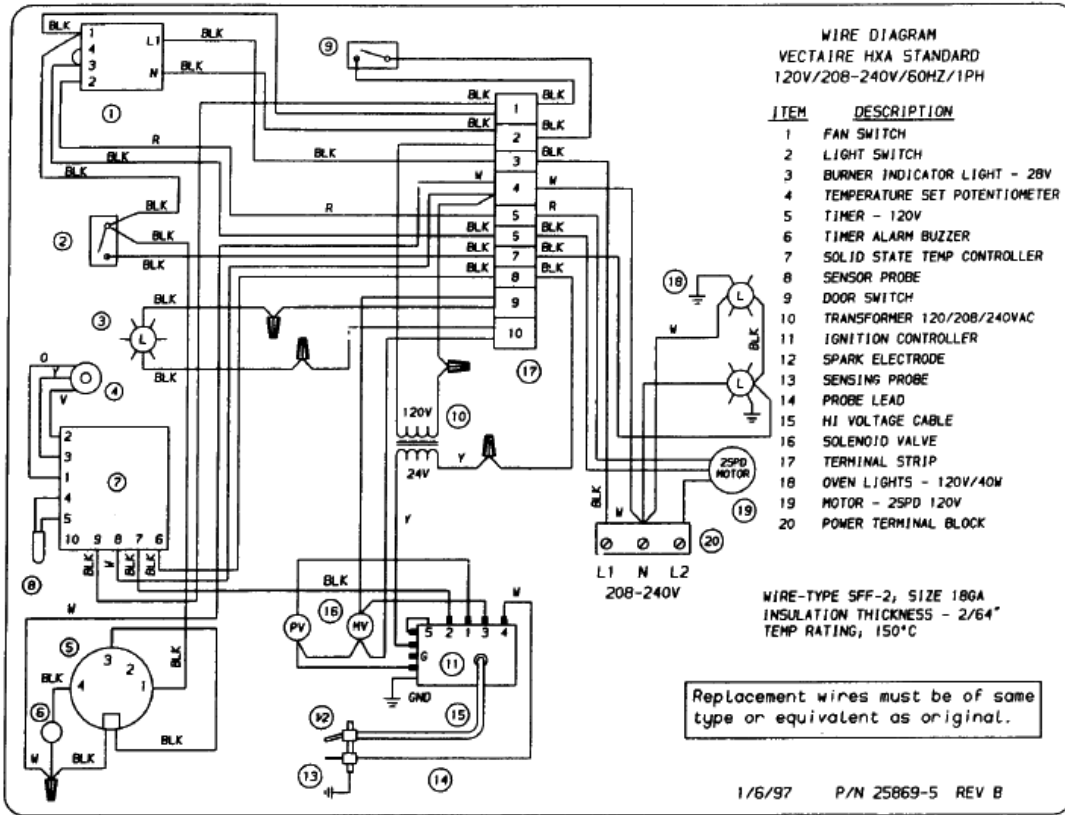

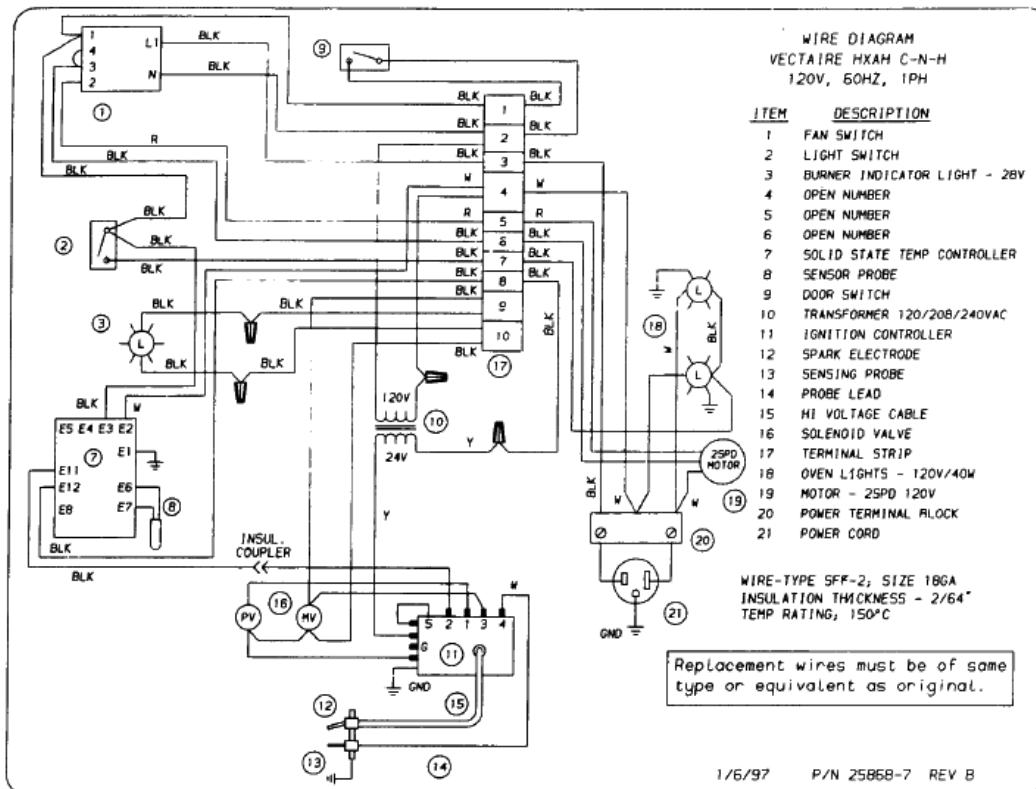
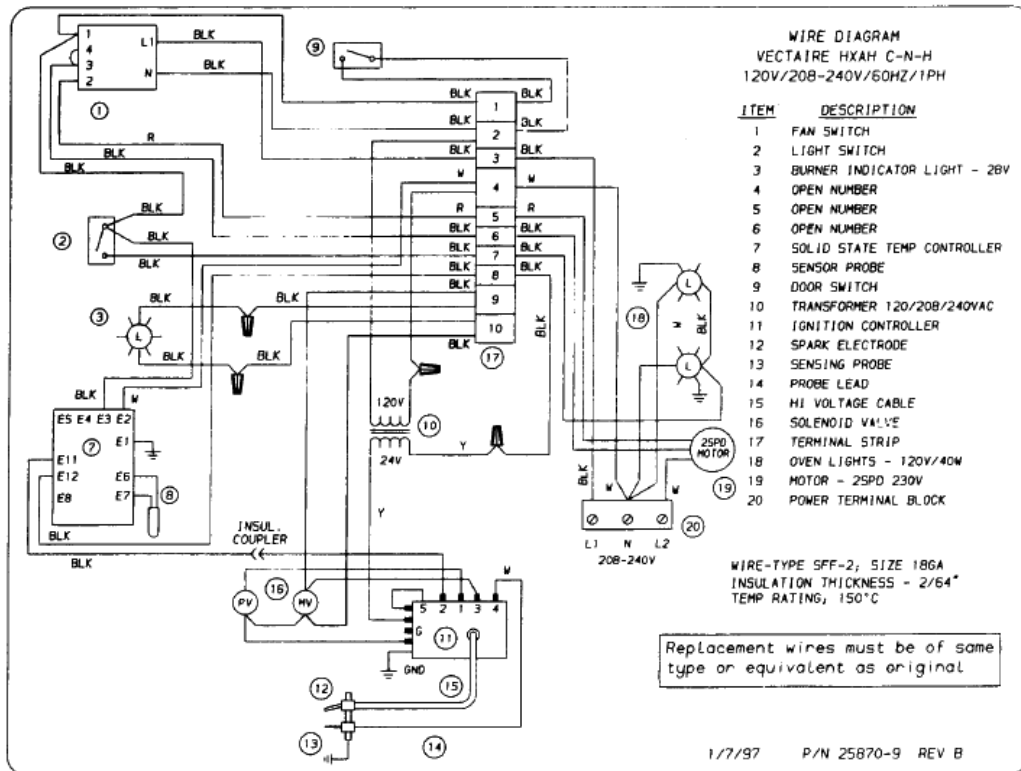

VECTAIRE- HX SERIES EXPLODED PARTS VIEW

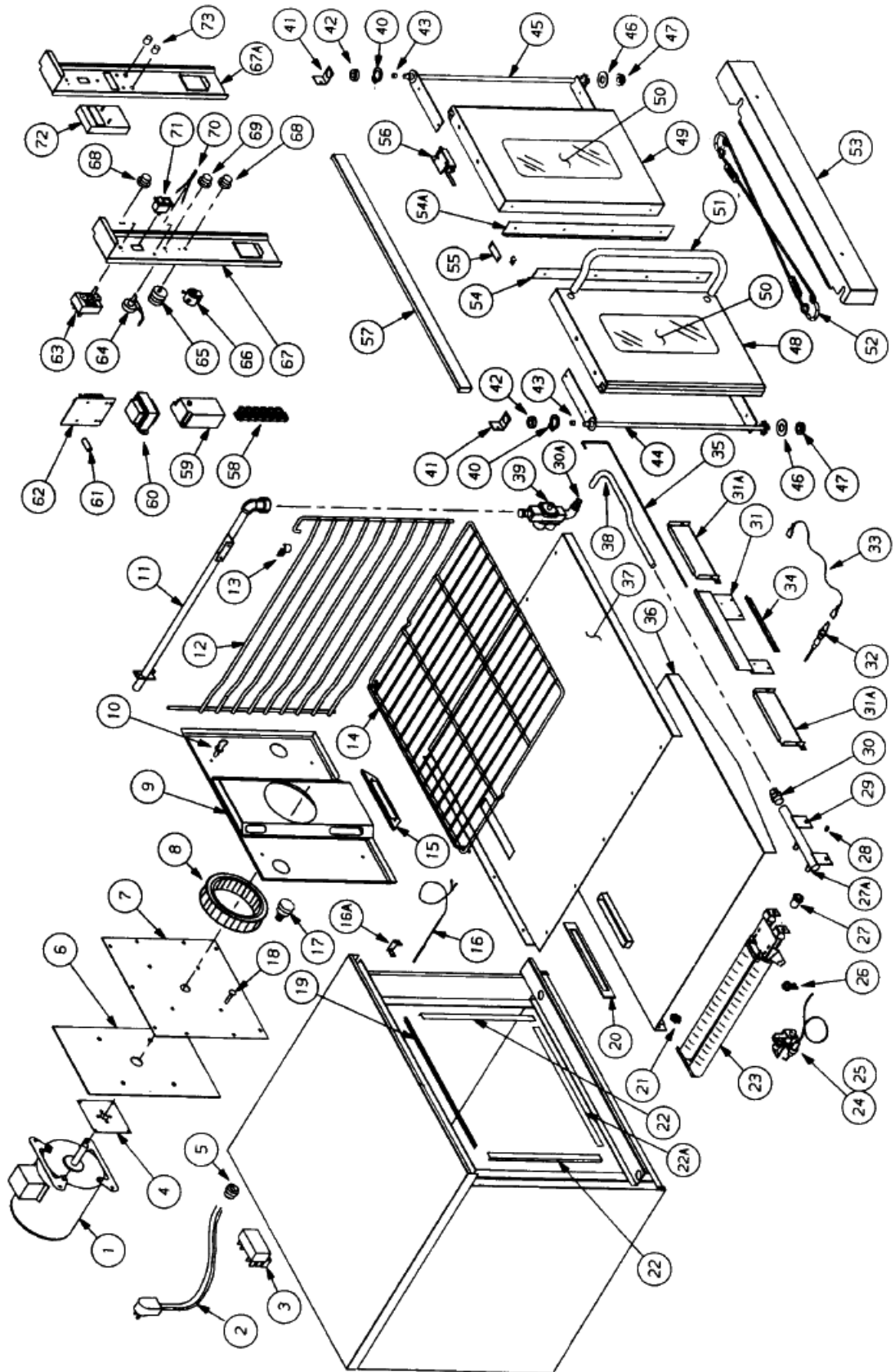

1	25881-4	Motor, 1/2hp 115V 1PH 60Hz MagneTek
	01397-8	Motor, 3/4hp 115V 1PH 60Hz Howell
	06371-1	Motor, 3/4hp 208/240V 1PH 60Hz Howell
2	01409-5	Cord, Electrical 6' Power
3	25878-4	Block, Power Terminal - 2 Pole
	08584-7	Block, Power Terminal - 3 Pole
4	04385-0	Spacer Plate, Motor
5	01395-1	Blushing, Strain Relief
6	01757-4	Insulation, Motor Mount
7	11643-2	Plate, Motor Assembly
8	25370-7	Blower Wheel
9	25310-3	Baffle, Rear Fan
10	01860-0	Screw, Thumb
11	25316-2	Manifold, Rear
12	01593-8	Guide, Rack - Right
	01594-6	Guide, Rack - Left
13	01389-7	Clamp, Rack Guide
14	01590-3	Rack, Wire
15	25201-8	Stainless Duct Trim
16	25376-6	Sensor, Oven - Std.
	19187-6	Sensor, Oven - C-N-H
16A	25331-6	Sensor Bracket
17	25372-3	Lamp Assembly w/ Bulb
	25380-4	Bulb - 120V, 40W
	25379-0	Bulb - 250V, 40W
18	01945-3	Screw, Motor Mount
19	26555-1	Door Seal - Upper
20	25355-3	Gasket, Heat Exchanger
21	01890-2	Nut, Heat Exchanger Lock
22	26554-3	Door Seal - Side
22A	26553-5	Door Seal - Bottom
23	25338-3	Main Burner Assembly
24	25386-3	Burner, Pilot Assembly - Natural Gas
	25387-1	Burner, Pilot Assembly - Propane Gas
25	25389-8	Orifice, Pilot Burner - Natural Gas
	25390-1	Orifice, Pilot Burner - Propane Gas
26	01420-6	Support, Cable
27	11700-5	Orifice, Main Burner - Natural Gas
	04340-0	Orifice, Main Burner - Propane Gas
27A	02668-9	Nipple, Hex Orifice
28	01279-3	Plug, 1/8" NPTM Brass
29	25315-4	Manifold, Burner
30	25398-7	Connector, Brass PXT - Female
30A	25967-5	Connector, Brass PXT - Male
31	25137-2	Burner Box Front - Center
31A	25139-9	Burner Box Front - Right/Left

32	25392-8	Sensor Probe
33	25394-4	Cable, Sensor Probe
34	25141-0	Pilot Shield Trim
35	25403-7	Pilot Tubing
36	25322-7	Heat Exchanger
37	25308-7	Liner, Bottom - Porcelain
38	25968-3	1/2" Al Tubing, Formed
39	26595-0	Valve, Combination Gas- Natural
	26596-9	Valve, Combination Gas- Propane
40	01961-5	Retainer, Self-Locking
41	25405-3	Keeper, Door Bearing
42	14445-2	Bearing, Oven Door
43	01260-2	Spacer
44	03239-5	Trunnion Assembly - Left
45	03585-8	Trunnion Assembly - Right
46	11350-6	Washer, Door Spacer
47	14445-2	Bearing, Oven Door
48	26012-6	Door Assembly - Handle Side
49	26011-8	Door Assembly - Left Side
50	26013-4	Window
51	03173-9	Handle, Oven Door
52	19601-0	Turnbuckle and Chain (2 Req'd)
53	25327-8	Panel, Burner Access
54	25530-0	Door Seal, Center Left
54A	25532-7	Door Seal, Center Right
55	24334-5	Catch, Spring/Ball
56	25874-1	Switch, Door
57	25170-4	Capping Panel, Upper Front
58	25877-6	Strip, Terminal
59	17198-0	Control, Electronic Ignition
60	25876-8	Transformer
61	25977-2	Electrical Stand Offs
62	25375-8	Controller, Oven Temp.
63	25373-1	Switch, 4-Position Rotary
64	25377-4	Potentiometer Assembly
65	25381-2	Timer, Electric - 115V / 60Hz
66	25873-3	Buzzer, Electric Time - 120V / 60Hz
67	25970-5	Control Panel - Standard
67A	25971-3	Control Panel - C-N-H
68	25378-2	Knob, Fan / Timer
69	24663-8	Knob, Thermostat
70	25872-5	Light, Burner indicator
71	23129-0	Switch, Light
72	26505-5	Controller, C-N-H
73	26504-7	Knob, Temp / Time

WARNING

If not installed, operated and maintained in accordance with the manufacturer's instructions, this product could expose you to substances in fuel or in fuel combustion which can cause death or serious illness and which are known to the State of California to cause cancer, birth defects or other reproductive harm.

The State of California enacted the California Safe Drinking Water and Toxic Enforcement Act of 1986, (Prop. 65), which "prohibits any person in the course of doing business from knowingly and intentionally exposing any individual to a chemical known to the State of California to cause cancer or reproductive toxicity without first giving clear and reasonable warning to such individuals." The Governor's Scientific Advisory Panel added carbon monoxide to the list of hazardous chemicals known to cause reproductive harm.

In order to establish full compliance with Proposition 65, we attached a yellow warning label to each gas fired unit manufactured by the Montague Company.

Carbon monoxide would not be present in concentrations that would pose a "significant risk" to the consumer when the equipment is installed, operated and maintained as follows:

1. Installed in accordance with all local codes, or in the absence of local codes, with the current National Fuel Gas Code Z223.1.
2. Installed under a properly designed and operating exhaust hood.
3. Connected to the type of gas for which the unit is equipped.
4. Proper appliance pressure regulator installed on the gas supply line and adjusted for the manifold pressure marked on the rating plate.
5. Adequate air supply to the unit.
6. The equipment is operated in the manner intended using the proper utensil for that type of appliance.
7. Keep the equipment clean and have it checked periodically.
8. Burner air adjustments, mechanical maintenance and repairs should be performed by qualified service personnel.

If the equipment is not installed, operated and maintained in accordance with the above, concentrations of carbon monoxide in excess of the established limits could present in the kitchen environment.

ALL PERSONNEL IN THE WORKPLACE WHO MAY BE SUBJECT TO ANY EXPOSURE OF CARBON MONOXIDE MUST BE WARNED OF SUCH POSSIBLE EXPOSURE. THIS WARNING SHOULD BE CONVEYED IN A MANNER SO THAT IT IS CLEARLY UNDERSTOOD BY THE EMPLOYEE, AND THE EMPLOYEE SHOULD BE ASKED IF IN FACT HE OR SHE UNDERSTANDS THE CORRECT METHOD OF OPERATION OF THE EQUIPMENT AND THAT A RISK OF EXPOSURE EXISTS IF THE EQUIPMENT IS OPERATED IMPROPERLY.



The MONTAGUE COMPANY
1830 Stearman Avenue, P.O. Box 4954 Hayward, CA 94540-4954

IMPORTANT

When ordering part, to eliminate mistakes and facilitate delivery, always give the following information:

Serial No. _____

Model No. _____

Change No. _____

Name & No. of Part

Model No. Change No. Serial No.

A diagram illustrating the layout of a part name and number. It consists of a large outer rectangle containing four smaller shapes: three horizontal rectangles and one square. The three rectangles are arranged horizontally from left to right. Lines connect the labels 'Model No.', 'Change No.', and 'Serial No.' (from the block above) to the top-left corners of the three rectangles respectively. The square is positioned to the right of the three rectangles.

The Montague Company
1830 Stearman Avenue
P.O. Box 4954
Hayward, CA 94540-4954

P/N 26015-0 9/97