

INSTRUCTION MANUAL

Effective October 1, 2001: All Montague heavy duty ranges and broilers will be built with orifices and regulators set to operate on 6" W.C. manifold pressure

You must specify the manifold pressure and gas type listed on the model identification plate to order replacement burner valves, orifices, or pressure regulators.

MONTAGUE LEGEND

Heavy Duty Underfired Gas Broilers

Ceramic Models

Range Match: UF (-24C, -30C, -36C, -48C, -60C, -72C)

Freestanding: UFS (-24C, -30C, -36C, -48C, -60C, -72C)

Modular: UFSM (-24C, -30C, -36C, -48C, -60C, -72C)

Counter: UFSC (-24C, -30C, -36C, -48C, -60C, -72C)

These instructions should be read thoroughly before attempting installation. Set up and installation should be performed by qualified installation personnel.

Keep area around appliances free and clear from combustibles.

PLEASE RETAIN THIS MANUAL
FOR FUTURE REFERENCE.



THE MONTAGUE COMPANY

1830 Stearman Avenue P.O. BOX 4954
HAYWARD, CA 94540-4954

TEL: 510/785-8822 FAX: 510/785-3342

CONTENTS

INSTALLATION	3	COOKING.....	8
CLEANING & MAINTENANCE.....	5	SERVICE.....	9
OPERATION	8		

IMPORTANT

WARNING:

Improper installation, adjustment, alteration, service or maintenance can cause property damage, injury or death. Read the operating and maintenance instructions thoroughly before installing or servicing this equipment.

FOR YOUR SAFETY:

Do not store or use gasoline or other flammable vapors and liquids in the vicinity of this or any other appliance.

INSTRUCTIONS TO BE FOLLOWED IN THE EVENT THE USER SMELLS GAS MUST BE POSTED IN A PROMINENT LOCATION. THIS INFORMATION MAY BE OBTAINED BY CONSULTING THE LOCAL GAS SUPPLIER.

SHIPPING DAMAGE CLAIM PROCEDURE

For your protection, please note that equipment in this shipment was carefully inspected and packed by skilled personnel before leaving the factory. The transportation company assumes full responsibility for safe delivery upon acceptance of this shipment.

If shipment arrives damaged:

1. **VISIBLE LOSS OR DAMAGE**—Be certain this is noted on freight bill or express receipt, and signed by person making delivery.
2. **FILE CLAIM FOR DAMAGES IMMEDIATELY**—Regardless of the extent of damage.
3. **CONCEALED LOSS OR DAMAGE**—If damage is unnoticed until merchandise is unpacked, notify transportation company or carrier immediately, and file “concealed damage” claim with them. This should be done within fifteen (15) days of date that delivery was made to you. Be sure to retain container for inspection.

We cannot assume responsibility for damage incurred in transit. We will, however, be glad to furnish you with necessary documents to support your claim.

INSTALLATION

The MONTAGUE gas broilers are produced with the best possible materials and workmanship. PROPER INSTALLATION IS ESSENTIAL FOR SAFE AND EFFICIENT TROUBLE-FREE OPERATION.

THE INSTALLATION INSTRUCTIONS CONTAINED HEREIN ARE FOR THE USE OF QUALIFIED INSTALLATION AND SERVICE PERSONNEL ONLY. INSTALLATION OR SERVICE BY OTHER THAN QUALIFIED PERSONNEL MAY RESULT IN DAMAGE TO THE BROILER/INJURY TO THE OPERATOR.

Qualified installation personnel are individuals, a firm, corporation, or company which either in person or through a representative are engaged in, and are responsible for:

- A. The installation or replacement of gas piping or the connection, installation, repair or servicing of equipment, who is experienced in such work, familiar with all precautions required, and has complied with all requirements of state or local authorities having jurisdiction. Reference: National Fuel Gas Code Z223.1, 1988, Sec. 1.4.
- B. The installation of electrical wiring from the electric meter, main control box, or service outlet to the electric appliance. Qualified installation personnel must be experienced in such work and be familiar with all precautions required and have complied with all requirements of state and local authorities having jurisdiction. Reference: National Electric Code, N.F.P.A. No. 70, 1988.

READ CAREFULLY AND FOLLOW THESE INSTRUCTIONS

THE OVEN MUST BE INSTALLED IN ACCORDANCE WITH THE LOCAL CODES, OR IN THE ABSENCE OF LOCAL CODES, WITH THE NATIONAL FUEL GAS CODE, ANSI Z223.1-1988, INCLUDING:

1. The appliance and its individual shutoff valve must be disconnected from the gas supply piping system during any pressure testing of that system at test pressures in excess of 1/2 psig. (3.45 kPa).
2. The appliance must be isolated from the gas supply piping system by closing its individual manual shutoff valve during any pressure testing of the gas supply piping system at test pressure equal to or less than 1/2 psig. (3.45 kPa).

PROVISIONS MUST BE MADE FOR ADEQUATE AIR SUPPLY TO THE UNIT.

Ventilating Hood

The broiler must be installed under a properly designed hood. The hood should extend at least 6" beyond all sides of the unit. The hood should be connected to an adequate mechanical exhaust system.

INSTALLATION

Information on the construction and installation of ventilation hoods may be obtained from the "Standard for the Installation of Equipment for the Removal of Smoke and Grease Laden Vapors from Commercial Cooking Equipment", NFPA No. 96-1987, available from the National Fire Protection Association, Batterymarch Park, Quincy, MA 02269.

It is also necessary that the sufficient room air ingress be allowed to compensate for the amount of air removed by the ventilation system. Otherwise, a subnormal atmospheric pressure will occur which may interfere with burner performance or may extinguish the pilot flame. In case of unsatisfactory oven performance, check with the exhaust fan turned "OFF".

Clearances

Adequate clearances must be provided in the aisle in front of the broiler for safe operation, removal of racks, drip tray, and grease container, and for serviceability. Adequate clearance for air openings into the combustion chamber must be provided.

<u>CLEARANCES</u>	
<u>UF, UFS, UFSM & UFSC MODELS:</u>	NONCOMBUSTIBLE CONSTRUCTION
BACK:	0"
LEFT & RIGHT SIDE:	0"
FOR USE IN NONCOMBUSTIBLE LOCATIONS ONLY	

CAUTION!
DO NOT OBSTRUCT THE FLOW OF COMBUSTION AND VENTILATION AIR TO THE BROILER(S). KEEP THE APPLIANCE AREA FREE AND CLEAR FROM COMBUSTIBLES.

Setting in Place

1. Uncrate unit and put into place. For easier and lighter handling of broiler, remove coals, cast iron top grids, grid frame, drip tray, grease container, and debris screen.
2. Wire ties securing burners are for shipping purposes only and must be removed when installing the appliance. This will permit the burners to be readily removed during future servicing.
3. FOR FLOOR MODELS, a set of 6" legs is packed in the top section of the broiler (unless unit is specifically ordered without legs) . A threaded receptacle is located on each corner (and in the middle of units larger than 36") of the base of the unit. Each leg has a similar mating thread. Raise unit sufficiently to allow legs to be screwed into the threaded receptacles. Level unit by adjusting legs. *AN UNLEVELED UNIT WILL ADVERSELY AFFECT PERFORMANCE.*
4. COUNTER UNITS must be installed on a *level* table or stand, and MODULAR UNITS must be leveled by adjusting the legs.

Battery Arrangements

1. Place the first unit in the exact position it will occupy in the battery.
2. Using a carpenter's level, level the unit from front to rear and side to side. Adjust as follows:

FLOOR INSTALLATION ON LEGS: Adjust by turning foot on adjustable legs.

CURB INSTALLATION: Place shim under the low side. This operation is important since variations in floors and curbs are common. Unless units are level, difficulty will be encountered in aligning the gas supply manifold and the units will not butt together tightly.

3. Remove the upper valve panel from unit.
4. Move the next unit into position.
5. Engage union nut on manifold with male fitting on next unit and draw up union nut hand tight. Be sure appliances butt together both front and rear. If manifolds do not align, then ranges are not level. In extreme cases, it may be necessary to loosen manifold bolts and adjust.
6. Continue leveling and connecting gas supply manifolds together until all appliances in the battery are connected.
7. Tighten manifold union gas tight. Use back up wrench to prevent manifold from rotating.
*FAILURE TO DO THIS MAY RESULT IN DAMAGE TO PILOTS AND GAS VALVES.
CHECK ENTIRE SYSTEM FOR GAS LEAKS.*

Gas Hook Up

An adequate gas supply is imperative. Undersized or low pressure lines will restrict the flow of gas required for satisfactory performance. A steady supply pressure between 7" and 8" WC for natural gas and 11" and 12" WC for propane gas is required. With all units operating simultaneously, the manifold pressure on all units should not show any appreciable drop. Fluctuation of more than 25% on natural gas and 10% on propane gas will create pilot problems and affect burner operating characteristics. Contact your gas company for correct supply line sizes.

The unit should be connected *only* to the type of gas for which it is equipped. Check type of gas on rating plate.

1. 1-1/4" FRONT MANIFOLD:
The gas manifold of this appliance or of the battery which it is a part must be connected to a gas appliance pressure regulator adjusted for the manifold pressure marked on the rating plate.

IMPORTANT

THE UNIT IS EQUIPPED WITH FIXED ORIFICES FOR THE TYPE OF GAS MARKED ON THE RATING PLATE. THE ORIFICES ARE SIZED FOR THE FOLLOWING MANIFOLD PRESSURE:

NATURAL GAS 4.0" WC PROPANE GAS10.0" WC

INSTALLATION

3/4" REAR MANIFOLD:

The gas pressure regulator supplied with this unit must be used.

FOR NATURAL GAS— the gas pressure regulator is factory adjusted for 4.0" WC manifold pressure. The maximum inlet pressure to the regulator should not exceed 10.5"WC.

FOR PROPANE GAS—the gas pressure regulator is factory adjusted for 10.0"WC manifold pressure. The maximum inlet pressure to the regulator should not exceed 21"WC.

2. Manifold pressure must be maintained at the pressure marked on the rating plate. Improper pressure can result in faulty or unsafe operation and/or premature component failure.
3. Use a pipe joint compound which is suitable for use with propane gas on all threaded connections.
4. Turn off all burner valves.
5. Turn on gas supply and check all unions for leaks. Use soapy water only for testing on all gases. *NEVER USE AN OPEN FLAME TO CHECK GAS LEAKS.*

Final Assembly

1. Reassemble the broiler by inserting the bottom grates (that will be used to hold the char-rock coals) with the flat surface facing down and properly positioned in their supports so they do not touch the burners. Spread the coals randomly over the grates to a maximum depth of 1-1/2". Rearrange the coals to eliminate void areas and large openings. The proper amount of char-rock coals are as follows:
-24C...7lbs. -30C...10lbs. -36C...12lbs -48C... 14lbs. -60C...20lbs. -72C...24lbs

If ceramic brickettes are used, the proper amounts are as follows:

-24C...15lbs. -30C...18lbs. -36C...22lbs -48C...30lbs. -60C...36lbs. -72C...44lbs

2. Reinstall the grid frame and top grids and check for proper operation of the grid adjustment lever. Replace the drip tray, grease container, and debris screen.

Gas Settings

PILOT LIGHTING INSTRUCTIONS:

1. Remove debris screen and light each pilot with matches or taper from underneath. Replace screen.
1. Set pilot valve with screwdriver to provide 1/2" flame by turning counterclockwise.
2. Turn desired burner valve on.
3. To shut down, turn pilot valve clockwise until tight.
4. Do not attempt to relight for 5 minutes after shut down.

The burner flame should be 1" to 1-1/2" high on natural gas and approximately 1/2" to 5/8" on propane gas. Turn the gas valve on and off several times and observe the flames on the burners. If they are yellow and soft, open the air shutter slightly or until yellow disappears. If flames seem to blow or lift from burner ports, close the air shutter until this does not occur. Secure air shutter after burner has been adjusted.

EXTERIOR:

Most of the exterior is stainless steel and enamel, and any reputable cleaner will keep this in good condition.

TOP GRIDS:

DAILY– Clean both sides regularly with a wire brush. Special attention should be given to the grease troughs on either side of the grid ribs, since this is where the rendered fat from the broiling operation runs off. If accumulation of carbon develops there, the fats will build up and drop from the points of carbon instead of running all the way down to the end of the grid into the grease trough.

WEEKLY– The grids should be removed at least once a week and be scrubbed thoroughly. Done regularly, this is an easy job; but if neglected, strong methods must be used.

CAST IRON GATES AND CERAMIC COALS:

Owing to the extreme heat required for char-broiling, the cast iron grates receive the greatest amount of wear. In busy operations, this could be in a 6-month period. To insure the longest possible life, coals and grates should be removed every few days and grates brushed. When grates become too badly warped, they should be replaced.

BURNERS:

Remove and clean the burners with a wire brush weekly. If burner ports are clogged, ream with a stiff wire. After one year, it's possible burners will warp and need replacing owing to the intense heat and radiation.

GREASE CONTAINERS:

Each unit contains at least one grease container to catch grease, (in the far left hand corner of the broiler), and at least one large tray to catch drippings from the broiler. The large tray should be removed every couple of days and washed thoroughly. The small grease container should be removed to empty accumulated grease and avoid overflow. The shield over the grease can protect it from the intense infra-red rays, avoiding a fire hazard. When these pans are out, it's a good idea to wipe out the interior of the unit with a warm soapy cloth to prevent grease and carbonization buildup.

DEBRIS SCREEN:

A removable debris screen is located above the drip tray to catch large particles that fall through the broiling grids. This should be removed and cleaned daily.

HEATING:

Be sure all standing pilots are lighted. Turn on the number of burners desired to the full “ON” position. After 20 minutes, the flame can be turned back to approximately the 3/4” position, or to maintain enough heat to keep the bottom of the coals glowing. These ceramic coals will be at broiling temperatures throughout, giving off the radiant heat necessary to provide fast boiling.

ADJUSTMENT OF TOP COOKING GRID:

To provide the operator with greater control over the cooking operation, a grid adjustment lever is located on the right side of the broiler cabinet. The rear of the grid can easily be adjusted during broiling into three positions: 1) *Horizontal*—for heating with pots or pans, or broiling round products (such as sausages) that could roll off. 2) *Moderately Tilted*—recommended for most broiling to maintain adequate drain-off of fat drippings and 3) *Steeply Angled*—to achieve maximum drain-off of fat drippings from high-fat products, or to reduce flare-ups during peak broiling periods. Some drippings will obviously fall onto the char-rock coals and create the smoke and charcoal broiled flavor exclusive to char-broiling.

LOWER WARMING RACK:

Simply pull out to load and push in to warm. Uses the radiant heat from above for added versatility from your MONTAGUE underfired broiler. Not recommended for direct broiling on the rack, and products are exposed to falling debris from grid above.

Cooking

The MONTAGUE Heavy Duty Underfired Gas Broilers were designed and built to outperform and outlast any other broilers available. They exhibit characteristics that chefs require to achieve high production broiling perfection.

HIGH HEAT CAPACITY:

The burners have been sized to maintain the 550°F—650°F broiling temperature better during peak loads. All products mark quickly and cook predictably.

EVEN GRID TEMPERATURES:

Temperatures throughout the greater middle and rear portions of the grid remain consistent. Slightly cooler sections exist at the front and outer edges of the grid to accommodate products that need to cook more slowly.

ULTRA-FLOW TOP GRIDS:

Wide spacing of ribs combined with generous openings for deeper penetrating radiant heat waves results in the ideal broiling atmosphere. Meats sear efficiently with more of the flavor and juices locked inside.

OPTIMUM FAT DRAIN-OFF:

Large continuous troughs on the top side of the broiling grids drain excess fat quickly. Adjustable grid angle allows for added control of flare-ups.

CONVENIENT LOWER WARMING RACK:

Expand the flexibility of your broiling operation with a lower rack that reached 350°F - 450°F during normal broiling. It can be used as a holding area for cooked products or warming shelf for plates and platters, finishing rack, or even for pan broiling seafood or shellfish.

SERVICE

WHEN SERVICE IS NEEDED, CONTACT A LOCAL SERVICE COMPANY, DEALER, OR THE FACTORY TO PERFORM MECHANICAL MAINTENANCE AND REPAIRS. THESE INSTRUCTIONS ARE INTENDED FOR USE BY COMPETENT SERVICE PERSONNEL.

CAUTION!
TURN OFF GAS AT MANUAL SHUT OFF VALVE NEXT TO THE APPLIANCE BEFORE ATTEMPTING TO LOOSEN ANY GAS CONNECTIONS.

Gas Pressure Regulator

WARNING!
NO UNTRAINED PERSON SHOULD ATTEMPT TO MAINTAIN OR SERVICE THE GAS PRESSURE REGULATOR.

Pilot Service

If pilot flame burns yellow, clean pilot to ensure a steady blue flame. This can be cleaned by washing in a solvent and/or blowing out with air.

Adjustment of pilot valve is located on the manifold behind the control panel. Clockwise is "OFF", counterclockwise is "ON". Flame height should be approximately 1/2".

Burner Valve

If burner valve becomes too difficult to turn:

1. Turn off gas to the unit.
2. Remove knobs and control panel.
3. Lift burner out.
4. Loosen nut on front of valve and remove stem.
5. Lubricate the valve stem with high temperature grease.
6. Reassemble.

Upon completion, turn gas on and check for leaks. The valve should be turned on and off several times to seat correctly.

Burner Box

For removal of burner box, contact the factory.

OPERATIONAL REMINDERS

- * BE SURE YOU HAVE NO MORE THAN 1-1/2" THICK LAYER OF COALS in the top of your broiler. Even slightly more can substantially raise the internal temperature, thereby decreasing the life of the parts. This will also cause hot and cold spots on the broiling grid.
- * BE SURE YOU CLEAN BOTH SIDES OF YOUR COOKING GRATE REGULARLY for efficient fat drain off. Remember, raising the cooking grates changes the temperature only slightly ... but it drains excess fat more quickly.
- * BE SURE YOUR BROILER BURNER VALVES ARE PROPERLY ADJUSTED to achieve a 550°F—650°F broiling surface. DO NOT OVERFIRE as you will cause premature component failure.
- * BE SURE TO INSPECT AND CLEAN THE PERFORATED SCREENS REGULARLY to reduce flare-up.

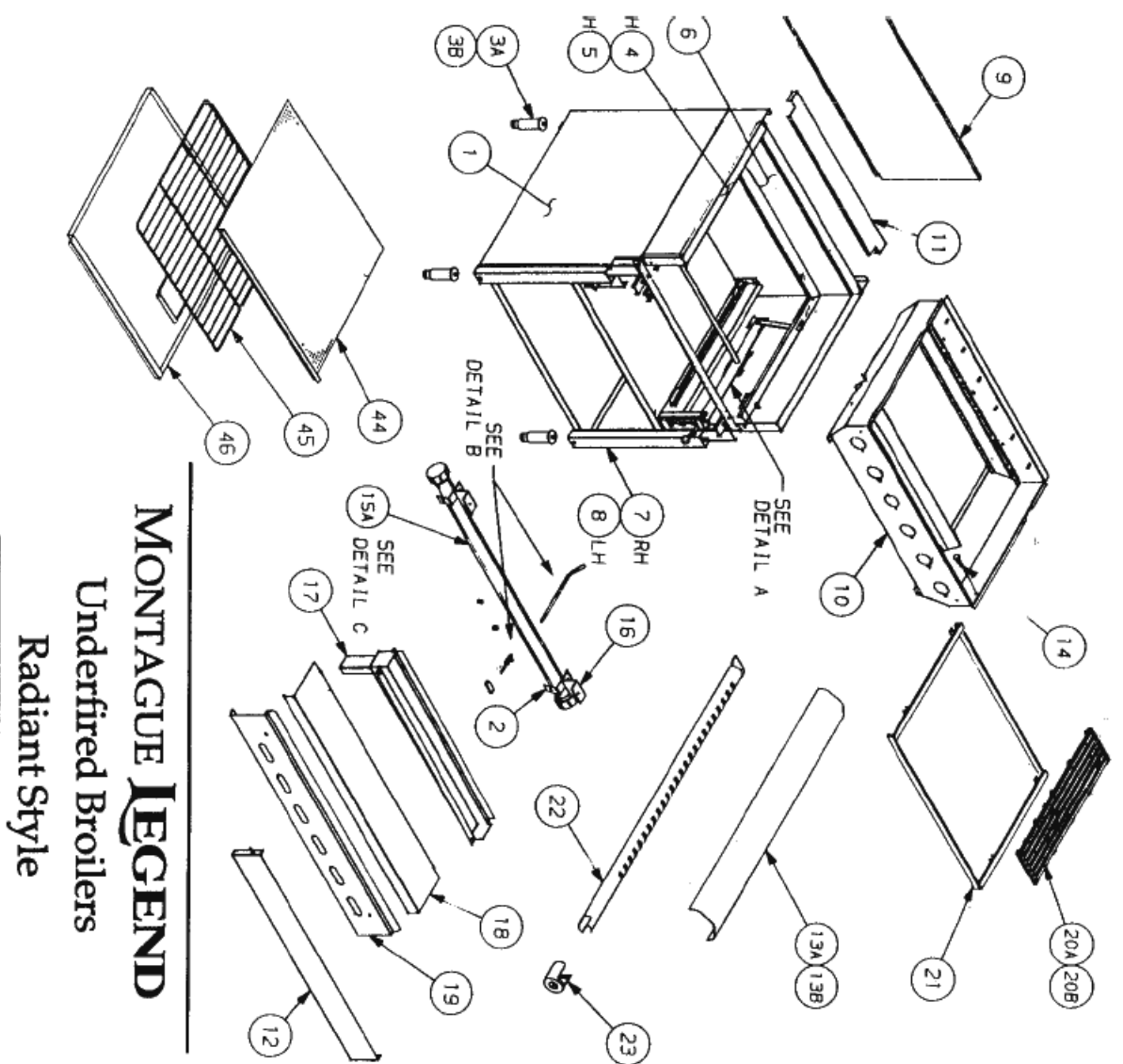

MONTAGUE LEGEND
Underfired Broilers
Radiant Style

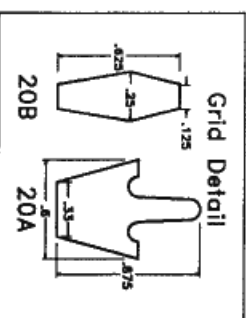
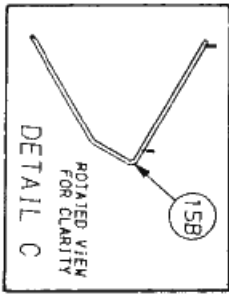
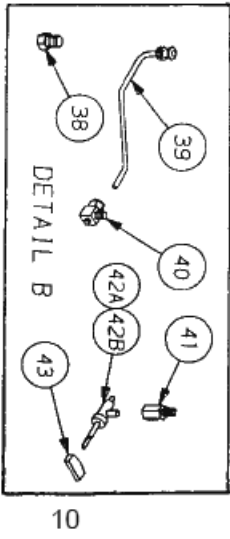
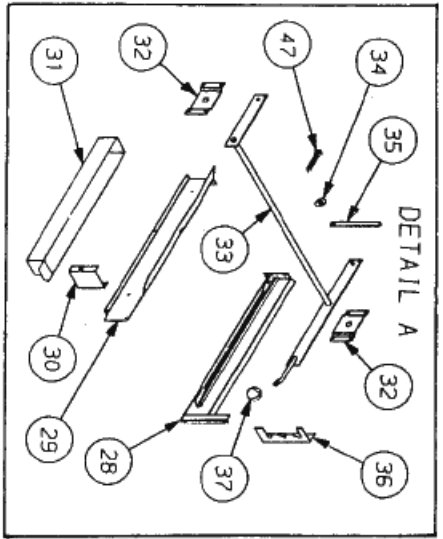

10

Underfired Broilers, Ceramic Style— Exploded Parts Diagram

Item	Description	24	30	36	Item	Description	24	30	36
1	Cabinet Base	20355-6	20402-1	13588-7	26	Burner	19609-6	19609-6	19609-6
2	Valve, Bracket	06137-9	06137-9	06137-9	27	Air Mixer	02038-9	02038-9	02038-9
3A	Leg w/ Foot - SS	03467-3	03467-3	03467-3	28	Liner, Warming Shelf- RT	19728-9	19728-9	19728-9
3B	Leg w/ Foot- PTID	03468-1	03468-1	03468-1	29	Liner, Warming Shelf- LT	19735-1	19735-1	19735-1
4	Top Trim Assy - LT	19413-1	19413-1	19413-1	30	Bracket, MTG	19738-6	19738-6	19738-6
5	Top Trim Assy - RT	19412-3	19412-3	19412-3	31	Grease Container	19752-1	19752-1	19752-1
6	Top Trim Rear- SS	20371-8	20422-6	19409-3	32	Lever MTG Bracket (X2)	19366-6	19366-6	19366-6
7	Trim Mullion - RT	19878-1	19878-1	19878-1	33	Lever Assy Grate	20234-7	20411-0	19363-1
8	Trim Mullion - LT	19881-1	19881-1	19881-1	34	Washer, Flat	01924-0	01924-0	01924-0
9	Back-Outer Panel	20349-1	20397-1	20318-1	35	Vertical Link	19374-7	19374-7	19374-7
10	Burner box Assy	20226-6	20452-8	19406-9	36	Bracket, Grid Adjustment	19726-2	19726-2	19726-2
11	Support Grate-Rear/LT		20435-8	19992-3	37	Knob, Red Ball	02033-8	02033-8	02033-8
12	Support Grate-Rear/Mid	19408-5		19408-5	38	Plug (BR) Pipe	01279-3	01279-3	01279-3
13	Support Grate-Rear/RT		20433-1	19993-1	39	Pilot Light	20323-8	20323-8	20323-8
14	Screw Cap w/ Shank	19847-1	19847-1	19847-1	40	Pilot Valve	01055-3	01055-3	01055-3
15A	Manifold	20239-8	20430-7	19847-1	41	Adapter Pipe	20082-4	20082-4	20082-4
15B	Manifold w/ Rear Conn	20239-8	20430-7	20006-9	42A	Valve Assy, Burner (N)	04328-1	04328-1	04328-1
16	Support Bracket	19839-0	19839-0	19839-0	42B	Valve Assy, Burner (LP)	02406-6	02406-6	02406-6
17	Broiler Trough	20243-6	20374-2	19858-7	43	Valve Handle	02002-8	02002-8	02002-8
18	Guard Rail Assy	20248-7	20363-7	20010-7	44	Screen, Debris	20564-8	20582-6	20585-0
19	Control Panel	20232-0	20428-5	20070-0	45	Wire Rack w/ Handle	20260-6	20259-2	19759-9
20A	Top Grid (Ultra Flow)	19692-4	19692-4	19692-4	46	Drip Container w/ SS Trim	20253-3	20379-3	19747-5
20B	Top Grid	09347-5	09347-5	09347-5	47	Cotter Pin	01931-3	01931-3	01931-3
21	Grid Frame Assy	20258-4	20347-5	19852-8	*48A	Pressure Regulator - Nat.	01039-4	01039-4	01039-4
22	Char-Rock	02073-7	02073-7	02073-7	*48B	Pressure Regulator- Prop.	01040-5	01040-5	01040-5
23	Grate, Bottom	09346-7	09346-7	09346-7	*48C	Pressure Regulator (Dbl.)- Nat.	02145-8	02145-8	02145-8
24	Screw, Drive	06997-3	06997-3	06997-3	*48D	Pressure Regulator (Dbl.)- Prop.	02146-6	02146-6	02146-6
25	Burner Shield	19868-4	19868-4	19868-4					

*Not Shown



The MONTAGUE COMPANY
1830 Stearman Avenue, P.O. Box 4954 Hayward, CA 94540-4954

WARNING

If not installed, operated and maintained in accordance with the manufacturer's instructions, this product could expose you to substances in fuel or in fuel combustion which can cause death or serious illness and which are known to the State of California to cause cancer, birth defects or other reproductive harm.

The State of California enacted the California Safe Drinking Water and Toxic Enforcement Act of 1986, (Prop. 65), which "prohibits any person in the course of doing business from knowingly and intentionally exposing any individual to a chemical known to the State of California to cause cancer or reproductive toxicity without first giving clear and reasonable warning to such individuals." The Governor's Scientific Advisory Panel added carbon monoxide to the list of hazardous chemicals known to cause reproductive harm.

In order to establish full compliance with Proposition 65, we attached a yellow warning label to each gas fired unit manufactured by the Montague Company.

Carbon monoxide would not be present in concentrations that would pose a "significant risk" to the consumer when the equipment is installed, operated and maintained as follows:

1. Installed in accordance with all local codes, or in the absence of local codes, with the current National Fuel Gas Code Z223.1.
2. Installed under a properly designed and operating exhaust hood.
3. Connected to the type of gas for which the unit is equipped.
4. Proper appliance pressure regulator installed on the gas supply line and adjusted for the manifold pressure marked on the rating plate.
5. Adequate air supply to the unit.
6. The equipment is operated in the manner intended using the proper utensil for that type of appliance.
7. Keep the equipment clean and have it checked periodically.
8. Burner air adjustments, mechanical maintenance and repairs should be performed by qualified service personnel.

If the equipment is not installed, operated and maintained in accordance with the above, concentrations of carbon monoxide in excess of the established limits could present in the kitchen environment.

ALL PERSONNEL IN THE WORKPLACE WHO MAY BE SUBJECT TO ANY EXPOSURE OF CARBON MONOXIDE MUST BE WARNED OF SUCH POSSIBLE EXPOSURE. THIS WARNING SHOULD BE CONVEYED IN A MANNER SO THAT IT IS CLEARLY UNDERSTOOD BY THE EMPLOYEE, AND THE EMPLOYEE SHOULD BE ASKED IF IN FACT HE OR SHE UNDERSTANDS THE CORRECT METHOD OF OPERATION OF THE EQUIPMENT AND THAT A RISK OF EXPOSURE EXISTS IF THE EQUIPMENT IS OPERATED IMPROPERLY.



The MONTAGUE COMPANY
1830 Stearman Avenue, P.O. Box 4954 Hayward, CA 94540-4954

IMPORTANT

Copy the following information from the rating plate for your records:

Model No. _____

Serial No. _____

Change No. _____

When ordering parts, to eliminate mistakes and facilitate delivery, always give the above information.



The Montague Company
1830 Stearman Avenue
P.O. Box 4954
Hayward, CA 94540-4954

P/N 2626-3 Rev. 192