

INSTRUCTION MANUAL

MONTAGUE LEGEND

Heavy Duty Underfired Gas Broilers

Radiant Models:

Range Match: UF (-24R, -30R, -36R, -48R, -60R, -72R)

Freestanding: UFS (-24R, -30R, -36R, -48R, -60R, -72R)

Low-Profile Counter: UFLC (-24R, -30R, -36R, -48R, -60R, -72R)

Modular: UFSM (-24R, -30R, -36R, -48R, -60R, -72R)

Counter: UFSC (-24R, -30R, -36R, -48R, -60R, -72R)

Shallow Counter: UFLCS (-24R, -30R, -36R, -48R, -60R, -72R)

These instructions should be read thoroughly before attempting installation.
Set up and installation should be performed by qualified installation personnel.

Keep area around appliances free and clear from combustibles.

PLEASE RETAIN THIS MANUAL
FOR FUTURE REFERENCE.



THE MONTAGUE COMPANY

1830 Stearman Avenue P.O. BOX 4954
HAYWARD, CA 94540-4954

TEL: 510/785-8822 FAX: 510/785-3342

CONTENTS

INSTALLATION 3
OPERATION 7

MAINTENANCE6
SERVICE 8

IMPORTANT

WARNING:

Improper installation, adjustment, alteration, service or maintenance can cause property damage, injury or death. Read the operating and maintenance instructions thoroughly before installing or servicing this equipment.

FOR YOUR SAFETY:

Do not store or use gasoline or other flammable vapors and liquids in the vicinity of this or any other appliance.

INSTRUCTIONS TO BE FOLLOWED IN THE EVENT THE USER SMELLS GAS MUST BE POSTED IN A PROMINENT LOCATION. THIS INFORMATION MAY BE OBTAINED BY CONSULTING THE LOCAL GAS SUPPLIER.

SHIPPING DAMAGE CLAIM PROCEDURE

For your protection, please note that equipment in this shipment was carefully inspected and packed by skilled personnel before leaving the factory. The transportation company assumes full responsibility for safe delivery upon acceptance of this shipment.

If shipment arrives damaged:

1. **VISIBLE LOSS OR DAMAGE**—Be certain this is noted on freight bill or express receipt, and signed by person making delivery.
2. **FILE CLAIM FOR DAMAGES IMMEDIATELY**—Regardless of the extent of damage.
3. **CONCEALED LOSS OR DAMAGE**—If damage is unnoticed until merchandise is unpacked, notify transportation company or carrier immediately, and file “concealed damage” claim with them. This should be done within fifteen (15) days of date that delivery was made to you. Be sure to retain container for inspection.

We cannot assume responsibility for damage incurred in transit. We will, however, be glad to furnish you with necessary documents to support your claim.

The MONTAGUE gas broilers are produced with the best possible materials and workmanship. PROPER INSTALLATION IS ESSENTIAL FOR SAFE AND EFFICIENT TROUBLE-FREE OPERATION.

THE INSTALLATION INSTRUCTIONS CONTAINED HEREIN ARE FOR THE USE OF QUALIFIED INSTALLATION AND SERVICE PERSONNEL ONLY. INSTALLATION OR SERVICE BY OTHER THAN QUALIFIED PERSONNEL MAY RESULT IN DAMAGE TO THE OVEN/INJURY TO THE OPERATOR.

Qualified installation personnel are individuals, a firm, corporation, or company which either in person or through a representative are engaged in, and are responsible for:

- A. The installation or replacement of gas piping or the connection, installation, repair or servicing of equipment, who is experienced in such work, familiar with all precautions required, and has complied with all requirements of state or local authorities having jurisdiction. Reference: National Fuel Gas Code Z223.1-NFPA54– latest addenda, Section 3.3.175.
- B. The installation of electrical wiring from the electric meter, main control box, or service outlet to the electric appliance. Qualified installation personnel must be experienced in such work be familiar with all precautions required and have complied with all requirements of state and local authorities having jurisdiction. Reference: National Electric Code, N.F.P.A. No. 70 – latest addenda.

READ CAREFULLY AND FOLLOW THESE INSTRUCTIONS

THE OVEN MUST BE INSTALLED IN ACCORDANCE WITH THE LOCAL CODES, OR IN THE ABSENCE OF LOCAL CODES, WITH THE NATIONAL FUEL GAS CODE, ANSI Z223.1-NFPA54-LATEST ADDENDA OR THE NATURAL GAS AND PROPANE INSTALLATION CODE CSA B149.1 AS APPLICABLE, INCLUDING:

1. The appliance and its individual shutoff valve must be disconnected from the gas supply piping system during any pressure testing of that system at test pressures in excess of 1/2 psig. (3.45 kPa).
2. The appliance must be isolated from the gas supply piping system by closing its individual manual shutoff valve during any pressure testing of the gas supply piping system at test pressure equal to or less than 1/2 psig. (3.45 kPa).

PROVISIONS MUST BE MADE FOR ADEQUATE AIR SUPPLY TO THE UNIT.

INSTALLATION

VENTILATING HOOD

The broiler must be installed under a properly designed ventilating hood. The hood should extend at least 6" beyond all sides of the unit. The hood should be connected to an adequate mechanical exhaust system.

Information on the construction and installation of ventilation hoods may be obtained from the "Standard for the Installation of Equipment for the Removal of Smoke and Grease Laden Vapors from Commercial Cooking Equipment", NFPA No. 96-latest addenda, available from the National Fire Protection Association, Batterymarch Park, Quincy, MA 02269.

It is also necessary that the sufficient room air ingress be allowed to compensate for the amount of air removed by the ventilation system. Otherwise, a subnormal atmospheric pressure will occur which may interfere with burner performance or may extinguish the pilot flame. In case of unsatisfactory oven performance, re-check performance with the exhaust fan turned "OFF".

Clearances

Adequate clearance must be provided in the aisle and at the side and back to allow the doors to open sufficiently to permit the removal of the racks and for serviceability. Adequate clearance for air openings into the combustion chamber must be provided.

CAUTION!
DO NOT OBSTRUCT THE FLOW OF COMBUSTION AND VENTILATION AIR TO THE BROILER(S). KEEP THE APPLIANCE AREA FREE AND CLEAR FROM COMBUSTIBLES.

CLEARANCES

	COMBUSTIBLE CONSTRUCTION	NONCOMBUSTIBLE CONSTRUCTION
<u>UF, UFS, UFSC & UFSM MODELS:</u>		
BACK:	4"	0"
LEFT & RIGHT SIDE:	8"	0"
<u>UFLC MODELS:</u>		
BACK:	6"	0"
LEFT & RIGHT SIDE:	9"	0"
<u>UF, UFS & UFSM MODELS:</u> SUITABLE FOR INSTALLATION ON COMBUSTIBLE FLOORS.		
<u>UFSC MODELS:</u> FOR USE ONLY ON NONCOMBUSTIBLE COUNTERS.		
<u>UFLC MODELS:</u> EQUIPPED WITH 4" HIGH LEGS FOR INSTALLATION ON NONCOMBUSTIBLE COUNTER.		
FOR USE ONLY WITH NONCOMUSTIBLE FLOORS.		

Setting in Place

1. Uncrate unit and put into place. For easier and lighter handling of the broiler, remove cast iron top grids, grid frame, drip tray, grease container, and debris screen.
2. Wire ties securing burners are for shipping purposes only and must be removed when installing the appliance. This will permit the burners to be readily removed during future servicing. Remove all other packing material from burner box.
3. FOR FLOOR MODELS, a set of 6" legs is packed in the top section of the broiler (unless unit is specifically ordered without legs). A threaded receptacle is located on each corner (and in the middle of units larger than 36") of the base of the unit. Each leg has a similar mating thread. Raise unit sufficiently to allow legs to be screwed into the threaded receptacles. Level unit by adjusting legs. **AN UNLEVELED UNIT WILL ADVERSELY AFFECT PERFORMANCE.**
4. COUNTER UNITS must be installed on a level table or stand, and Modular units must be leveled by adjusting the legs.

Battery Arrangements

1. Place the first unit in the exact position it will occupy in the battery.
2. Using a carpenter's level, level the unit from front to rear and side to side. Adjust as follows:
FLOOR INSTALLATION ON LEGS: Adjust by turning foot on adjustable legs.
CURB INSTALLATION: Place shim under the low side. This operation is important since variations in floors and curbs are common. Unless units are level, difficulty will be encountered in aligning the gas supply manifold and the units will not butt together tightly.
3. Remove the upper valve panel from unit.
4. Move the next unit into position.
5. Engage union nut on manifold with make fitting on next unit and draw up union nut hand tight. Be sure appliances butt together both front and rear. If manifolds do not align, then ranges are not level. In extreme cases, it may be necessary to loosen manifold bolts and adjust.
6. Continue leveling and connecting gas supply manifolds together until all appliances in the battery are connected.
7. Tighten manifold union gas tight. Use back up wrench to prevent manifold from rotating.
**FAILURE TO DO THIS MAY RESULT IN DAMAGE TO PILOTS AND GAS VALVES.
CHECK ENTIRE SYSTEM FOR GAS LEAKS.**

INSTALLATION

Gas Hook Up

An adequate gas supply is imperative. Undersized or low pressure lines will restrict the flow of gas required for satisfactory performance. A steady supply pressure between 7" and 8" WC for natural gas and 11" to 12" WC for propane gas is required. With all units operating simultaneously, the manifold pressure on all units should not show any appreciable drop. Fluctuation of more than 25% on natural gas and 10% on propane gas will create pilot problems and affect burner operating characteristics. Contact your gas company for correct supply line sizes.

The unit should be connected only to the type of gas for which it is equipped. Check type of gas on rating plate.

1. 1-1/4" FRONT MANIFOLD:

The gas manifold of this appliance or of the battery which it is a part must be connected to a gas appliance pressure regulator adjusted for the manifold pressure marked on the rating plate.

IMPORTANT

THIS UNIT IS EQUIPPED WITH FIXED ORIFICES FOR THE TYPE OF GAS MARKED ON THE RATING PLATE. THE ORIFICES ARE SIZED FOR THE FOLLOWING GAS PRESSURE:

NATURAL 6.0"WC

PROPANE GAS 10.0"WC

3/4" REAR MANIFOLD:

The gas pressure regulator supplied with this unit must be used.

FOR NATURAL GAS—the gas pressure regulator is factory adjusted for 6.0" WC manifold pressure. The maximum inlet pressure to the regulator should not exceed 10.5"WC.

FOR PROPANE GAS—the gas pressure regulator is factory adjusted for 10.0"WC manifold pressure. The maximum inlet pressure to the regulator should not exceed 21"WC.

2. Use a pipe joint compound which is suitable for use with Propane gas on all threaded connections.
3. Manifold pressure must be maintained at the pressure marked on the rating plate — 6.0"WC for natural and 10.0"WC for propane gas.
4. Turn off all burner valves.
5. Turn on gas supply and check all unions for leaks. Use soapy water only for testing on all gases. NEVER USE AN OPEN FLAME TO CHECK GAS LEAKS.

Final Assembly

1. Reinstall the grid frame and top grids and check for proper operation of the grid adjustment lever. Check to be certain that all tie wires have been removed from the burners and that the reflectors and radiants are properly positioned between their alignment notches. Replace the drip tray grease container, debris screen, and heat shields.

Gas Settings

PILOT LIGHTING INSTRUCTIONS:

1. Remove debris screen and light each pilot with matches or taper from underneath. Replace screen.
2. Set pilot valve with screwdriver to provide 1/2" flame by turning counterclockwise.
3. Turn desired burner valve on.
4. To shutdown, turn pilot valve clockwise until tight.
5. Do not attempt to relight for 5 minutes after shutdown.

The burner flame should be 1-1/2" to 2" high on natural gas and approximately 3/4" to 1" on propane gas. Turn the gas valve on and off several times and observe the flames on the burners. If they are yellow and soft, open the air shutter slightly or until yellow disappears. If flames seem to blow or lift from burner ports, close the air shutter until this does not occur. Secure air shutter after burner has been adjusted.

CLEANING AND MAINTENANCE

EXTERIOR:

Most of the exterior is stainless steel and enamel, and any reputable cleaner will keep this in good condition.

TOP GRIDS:

DAILY– Clean both sides regularly with a wire brush. Special attention should be given to the grease troughs on either side of the grid ribs, since this is where the rendered fat from the broiling operation runs off. If accumulation of carbon develops there, the fats will build up and drop from the points of carbon instead of running all the way down to the end of the grid into the grease trough.

WEEKLY– The grids should be removed at least once a week and be scrubbed and boiled thoroughly. Done regularly, this is an easy job; but if neglected, strong methods must be used.

RADIANTS:

Stainless steel radiants require only occasional cleaning since most food particles don't stick to their surface. They should be inspected weekly, and if cleaning is required, hot soapy water is best. Cast iron radiants are also self cleaning. If occasional cleaning is required, a wire brush and soapy water is usually adequate. Dry them before returning to the broiler.

BURNERS:

Under normal use, burners should not require cleaning, but periodic inspection for heat deterioration is recommended.

GREASE CONTAINERS:

Each unit contains at least one grease container to catch grease, (in the far left hand corner of the broiler), and at least one large tray to catch drippings from the broiler. The large tray should be removed every couple of days and washed thoroughly. The small grease container should be removed to empty accumulated grease and avoid overflow. This should be done while warm so that the grease is in a liquid state. The shield over the grease can protect it from the intense infrared rays, avoiding a fire hazard. When these pans are out, it's a good idea to wipe out the interior of the unit with a warm soapy cloth to prevent grease and carbonization buildup. The heat shields in UFLC models should be removed and cleaned daily in warm, soapy water.

DEBRIS SCREEN:

A removable debris screen is located above the drip tray to catch large particles that fall through the broiling grids. This should be removed and cleaned daily.

RADIANT REFELCTORS:

The radiant reflectors located beneath the burners in UFLC models should be removed weekly and scrubbed and boiled to remove burned fat drippings.

HEATING:

Be sure all standing pilots are lighted. Turn on the number of burners desired, to the full ON position. After 20 minutes, the flame can be turned back if less heat is desired. At broiling temperature, the radiants will reach a dull, red color with brighter areas at the edges. They generate the radiant heat necessary for fast broiling.

ADJUSTMENT OF TOP COOKING GRID:

UF, UFS, UFSC & UFSM models: To provide the operator with greater control over the cooking operation, a grid adjustment lever is located on the right side of the broiler cabinet. The rear of the grid can easily be adjusted during broiling into three position: 1) Horizontal—for heating with pots or pans, or broiling round products (such as sausages) that could roll off. 2) Moderately Tilted—recommended for most broiling to maintain adequate drain-off of fat drippings and 3) Steeply Angled— to achieve maximum drain-off of fat drippings from high-fat products, or to reduce flare-ups during peak broiling periods. Some drippings will obviously fall onto the hot radiants and create the smoke and charcoal broiled flavor exclusive to char-broiling.

UFLC models: With the top grids removed, the grid frame can be positioned by locating the rear support rod on the grid frame. With the rod extended and locked into the rear supports, the grids will drain off fat drippings produced during broiling. By retracting the rod, the grid frame will lay flat for heating pots or broiling round products. **NEVER TRY TO POSITION THE GRID FRAME WHILE THE BROILER IS OPERATING OR STILL HOT!**

LOWER WARMING RACK (US, UFS, UFSC & UFSM Models):

Simply pull out to load and push in to warm. Uses the radiant heat from above for added versatility from your MONTAGUE underfired broiler. Not recommended for direct cooking on the rack. Products are exposed to falling debris from grid above and probably will require covering.

Cooking

The MONTAGUE Heavy Duty Underfired Gas Broilers were designed and built to outperform and outlast any other broilers available. They exhibit characteristics that chefs require to achieve high production broiling perfection.

HIGH HEAT CAPACITY:

The burners have been sized to maintain the 550°F—650°F broiling temperature better during peak loads. All products mark quickly and cook predictably.

EVEN GRID TEMPERATURES:

Temperatures throughout the greater middle and rear portions of the grid remain consistent. Slightly cooler sections exist at the front and outer edges of the grid to accommodate products that need to cook more slowly.

ULTRA-FLOW TOP GRIDS:

Wide spacing of ribs combined with generous openings for deeper penetrating radiant heat waves results in the ideal broiling atmosphere. Meats sear efficiently with more of the flavor and juices locked inside.

OPTIMUM FAT DRAIN-OFF:

Large continuous troughs on the top side of the broiling grids drain excess fat quickly. Adjustable grid angle allows for added control of flare-ups.

CONVENIENT LOWER WARMING RACK, (UF, UFS, UFSC & UFSM models):

Expand the flexibility of your broiling operation with a lower rack that reaches 150°F - 250°F during normal broiling. It can be used as a holding area for cooked products or warming shelf for plates and platters.

SERVICE

WHEN SERVICE IS NEEDED, CONTACT A LOCAL SERVICE COMPANY, DEALER, OR THE FACTORY TO PERFORM MECHANICAL MAINTENANCE AND REPAIRS. THESE INSTRUCTIONS ARE INTENDED FOR USE BY COMPETENT SERVICE PERSONNEL.

CAUTION!
TURN OFF GAS AT MANUAL SHUT OFF VALVE NEXT TO THE APPLIANCE BEFORE ATTEMPTING TO LOOSEN ANY GAS CONNECTIONS.

Gas Pressure Regulator

WARNING!
NO UNTRAINED PERSON SHOULD ATTEMPT TO MAINTAIN OR SERVICE THE GAS PRESSURE REGULATOR.

Pilot Service

If pilot flame burns yellow, clean pilot to ensure a steady blue flame. This can be cleaned by washing in a solvent and/or blowing out with air.

Adjustment of pilot valve is located on the manifold behind the control panel. Clockwise is off, counterclockwise is on. Flame height should be approximately 1/2".

Burner Valve

If burner valve becomes too difficult to turn:

1. Turn off gas to the unit.
2. Remove knobs and control panel.
3. Lift burner out.
4. Loosen nut on front of valve and remove stem.
5. Lubricate the valve stem with high temperature grease.
6. Reassemble.

Upon completion, turn gas on and check for leaks. The valve should be turned on and off several times to seat correctly.

Burner Box

For removal of burner box, contact the factory.

OPERATIONAL REMINDERS

- * BE SURE YOU CLEAN BOTH SIDES OF YOUR COOKING GRATE REGULARLY for efficient fat drain off. Remember, raising the cooking grates changes the temperature only slightly ... but it drains excess fat more quickly.
- * BE SURE YOUR BROILER BURNER VALVES ARE PROPERLY ADJUSTED to achieve a 550°F - 650°F broiling surface. DO NOT OVERFIRE as you will cause premature component failure.
- * BE SURE TO INSPECT AND CLEAN THE PERFORATED SCREENS REGULARLY to reduce flare-up.
- * BE SURE TO KEEP THE RADIANT REFLECTORS AND HEAT SHIELDS CLEAN on low-profile counter models to reduce flare-up.

MONTAGUE LEGEND

Underfired Broilers

Radiant Style

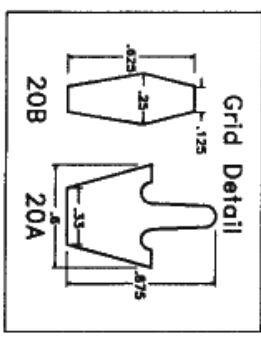
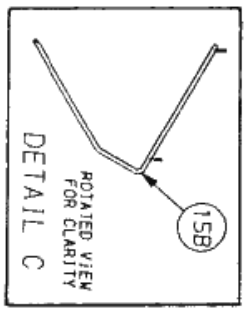
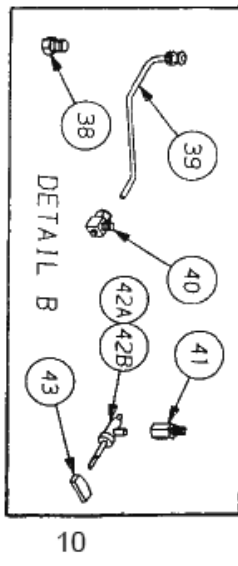
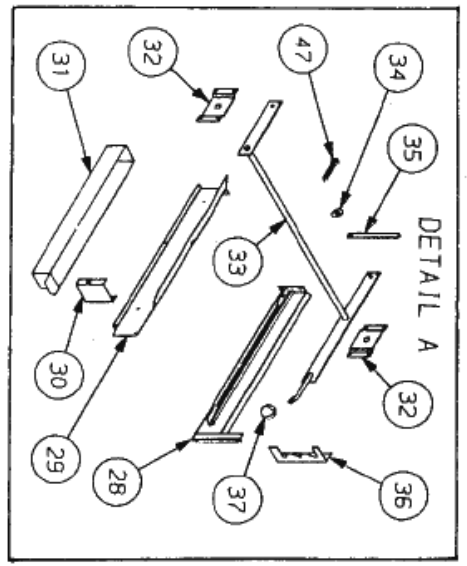
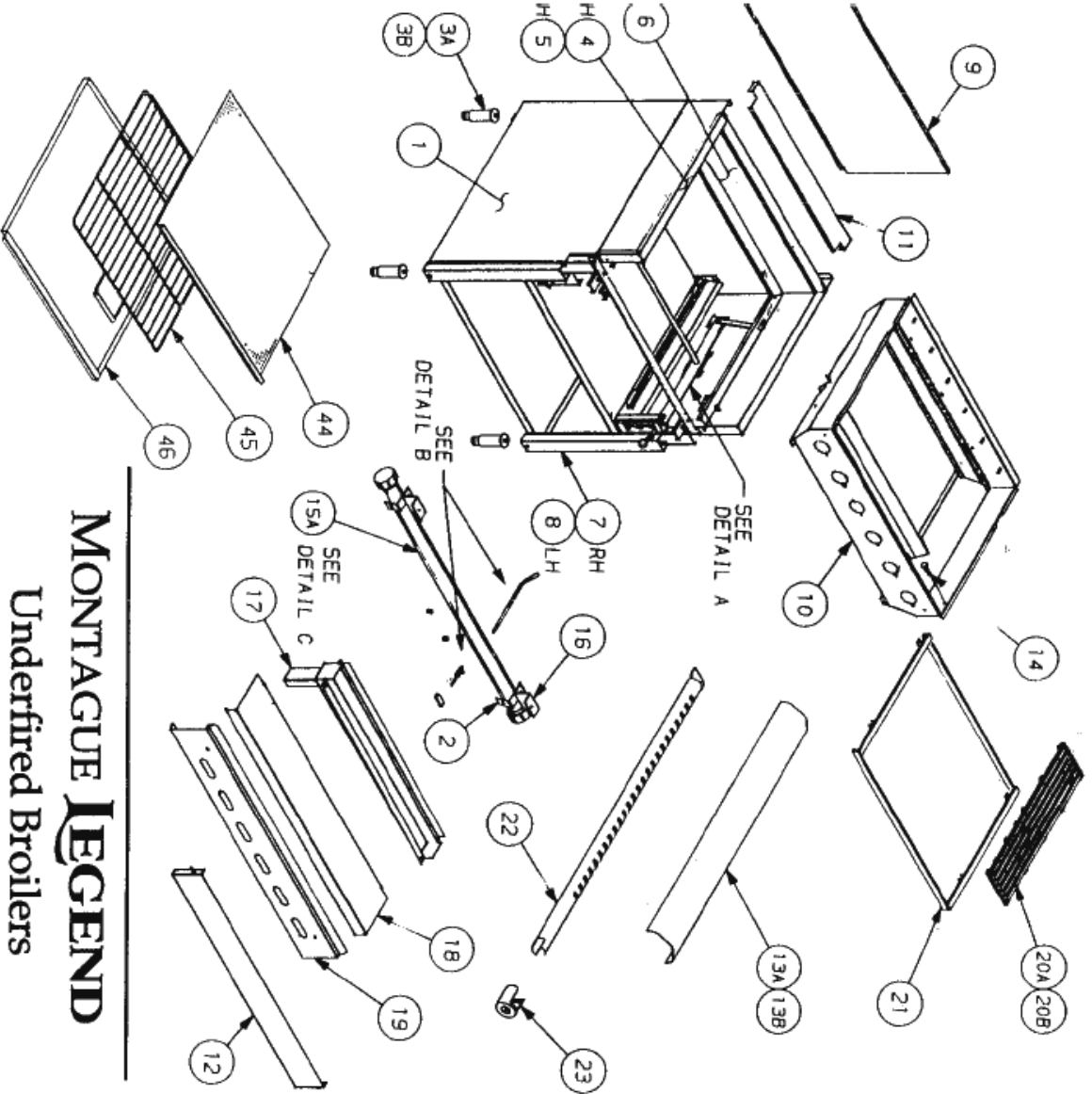

Underfired Broilers, Radiant Style— Exploded Parts Diagram

Item	Description	24	30	36	Item	Description	24	30	36
1	Cabinet Base	20355-6	20402-1	13588-7	28	Liner, Warming Shelf- RT	19728-9	19728-9	19728-9
2	Valve, Bracket	06137-9	06137-9	06137-9	29	Liner, Warming Shelf- LT	19735-1	19735-1	19735-1
3A	Leg w/ Foot - SS	03467-3	03467-3	03467-3	30	Bracket, MTG	19738-6	19738-6	19738-6
3B	Leg w/ Foot- PTD	03468-1	03468-1	03468-1	31	Grease Container	19752-1	19752-1	19752-1
4	Top Trim Assy - LT	19413-1	19413-1	19413-1	32	Lever MTG Bracket (X2)	19366-6	19366-6	19366-6
5	Top Trim Assy - RT	19412-3	19412-3	19412-3	33	Lever Assy Grate	20234-7	20411-0	19363-1
6	Top Trim Rear- SS	20371-8	20422-6	19409-3	34	Washer, Flat	01924-0	01924-0	01924-0
7	Trim Mullion - RT	19878-1	19878-1	19878-1	35	Vertical Link	19374-7	19374-7	19374-7
8	Trim Mullion - LT	19881-1	19881-1	19881-1	36	Bracket, Grid Adjustment	19726-2	19726-2	19726-2
9	Back-Outer Panel	20349-1	20397-1	20318-1	37	Knob, Black Oval	22269-0	22269-0	22269-0
10	Burner box Assy	20483-8	20716-0	20110-3	38	Plug (BR) Pipe	01279-3	01279-3	01279-3
11	Cover, Debris, Rear	20793-4	20730-6	20332-7	39	Pilot Lighter	20535-4	20535-4	20535-4
12	Deflector, Door	20934-1	20933-3	20932-5	40	Pilot Valve	01055-3	01055-3	01055-3
13A	Radiant	20122-7	20122-7	20122-7	42A	Valve Assy, Burner (N)	02406-6	02406-6	02406-6
13B	Radiant- Cast Iron	20531-1	20531-1	20531-1	42B	Valve Assy, Burner (LP)	01003-0	01003-0	01003-0
14	Screw Cap w/ Shank	19847-1	19874-1	19847-1	43	Valve Handle	02002-8	02002-8	02002-8
15A	Manifold	20239-8	20430-7	20006-9	44	Screen, Debris	20564-8	20582-6	20585-0
15B	Manifold w/ Rear Conn	20012-3	20012-3	20012-3	45	Wire Rack w/ Handle	20260-6	20259-2	19759-9
16	Support Bracket	19839-0	19839-0	19839-0	46	Drip Container w/ SS Trim	20253-3	20379-3	19747-5
17	Broiler Trough	20243-6	20374-2	19858-7	47	Cotter Pin	01931-3	01931-3	01931-3
18	Guard Rail Assy	20248-7	20363-7	20010-7	*48A	Pressure Regulator - Nat.	01039-1	01039-1	01039-1
19	Control Panel	20474-9	20721-7	20007-7	*48B	Pressure Regulator - Prop.	01040-5	01040-5	01040-5
20A	Top Grid (Ultra Flow)	19692-4	19692-4	19692-4	*48C	Pressure Regulator - (Dbl.) - Nat.	02145-8	02145-8	02145-8
20B	Top Grid (Narrow Rib)	09347-5	09347-5	09347-5	*48D	Pressure Regulator - (Dbl.) - Prop.	02146-6	02146-6	02146-6
21	Grid Frame Assy	20258-4	20347-5	19852-8					
22	Burner	20486-2	20486-2	20486-2					
23	Air shutter w/ screen	20663-8	02663-8	02663-8					

*Not



The MONTAGUE COMPANY
1830 Stearman Avenue, P.O. Box 4954 Hayward, CA 94540-4954

WARNING

If not installed, operated and maintained in accordance with the manufacturer's instructions, this product could expose you to substances in fuel or in fuel combustion which can cause death or serious illness and which are known to the State of California to cause cancer, birth defects or other reproductive harm.

The State of California enacted the California Safe Drinking Water and Toxic Enforcement Act of 1986, (Prop. 65), which "prohibits any person in the course of doing business from knowingly and intentionally exposing any individual to a chemical known to the State of California to cause cancer or reproductive toxicity without first giving clear and reasonable warning to such individuals." The Governor's Scientific Advisory Panel added carbon monoxide to the list of hazardous chemicals known to cause reproductive harm.

In order to establish full compliance with Proposition 65, we attached a yellow warning label to each gas fired unit manufactured by the Montague Company.

Carbon monoxide would not be present in concentrations that would pose a "significant risk" to the consumer when the equipment is installed, operated and maintained as follows:

1. Installed in accordance with all local codes, or in the absence of local codes, with the current National Fuel Gas Code Z223.1.
2. Installed under a properly designed and operating exhaust hood.
3. Connected to the type of gas for which the unit is equipped.
4. Proper appliance pressure regulator installed on the gas supply line and adjusted for the manifold pressure marked on the rating plate.
5. Adequate air supply to the unit.
6. The equipment is operated in the manner intended using the proper utensil for that type of appliance.
7. Keep the equipment clean and have it checked periodically.
8. Burner air adjustments, mechanical maintenance and repairs should be performed by qualified service personnel.

If the equipment is not installed, operated and maintained in accordance with the above, concentrations of carbon monoxide in excess of the established limits could present in the kitchen environment.

ALL PERSONNEL IN THE WORKPLACE WHO MAY BE SUBJECT TO ANY EXPOSURE OF CARBON MONOXIDE MUST BE WARNED OF SUCH POSSIBLE EXPOSURE. THIS WARNING SHOULD BE CONVEYED IN A MANNER SO THAT IT IS CLEARLY UNDERSTOOD BY THE EMPLOYEE, AND THE EMPLOYEE SHOULD BE ASKED IF IN FACT HE OR SHE UNDERSTANDS THE CORRECT METHOD OF OPERATION OF THE EQUIPMENT AND THAT A RISK OF EXPOSURE EXISTS IF THE EQUIPMENT IS OPERATED IMPROPERLY.



The MONTAGUE COMPANY

1830 Stearman Avenue, P.O. Box 4954 Hayward, CA 94540-4954

IMPORTANT

When ordering part, to eliminate mistakes and facilitate delivery, always give the following information:

Serial No. _____

Model No. _____

Change No. _____

Name & No. of Part

Model No. Change No. Serial No.

A diagram illustrating the layout of a part name and number. It consists of a large outer rectangle containing four smaller shapes: three horizontal rectangles and one square. The three rectangles are arranged horizontally from left to right. Lines connect the labels 'Model No.', 'Change No.', and 'Serial No.' (from the block above) to the top-left corners of the three rectangles respectively. The square is positioned to the right of the three rectangles.

The Montague Company
1830 Stearman Avenue
P.O. Box 4954
Hayward, CA 94540-4954

P/N 21508-2 8/08