

# FTA-290, FSA-291, HPA-310, HKA-320, & HCA-330 FLOOR SERIES ICE DISPENSERS INSTALLATION/OWNER'S/SERVICE MANUAL



Model FSA291  
with Cuber



Model HPA310\*

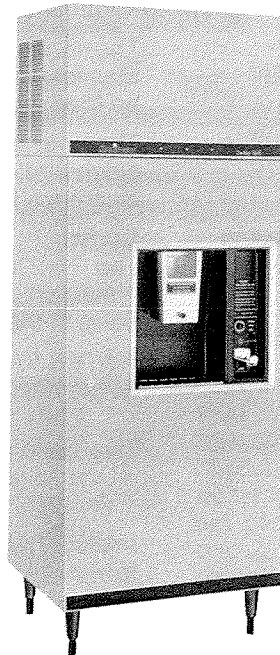

Model HCA330\*

## **MANITOWOC ICE, INCORPORATED**

2110 South 26th Street, P.O. Box 1720, Manitowoc, WI 54221-1720 • Phone: 414-682-0161  
©MANITOWOC 1989

80-0370-3  
Rev., Jan. 1997

## FREIGHT DAMAGE AND LOSS INFORMATION

### A. SHORTAGES

1. Check that the number of cartons delivered matches the quantity shown on your receipt.
2. If the quantities do not tally, have the driver note the shortage and file your claim accordingly.

### B. NO-FAULT FREIGHT CLAIM PROGRAM

Manitowoc assumes responsibility for all freight damage claims involving participating carriers, except when:

1. The trucking company loses the equipment.
2. Fire destroys the equipment en route.
3. A traffic accident damages the shipment en route.

### C. VISIBLE DAMAGE

1. Open all damaged cartons and inspect their contents.
2. To remove the carton, cut the banding and slide the carton up off the unit.
3. Note the location and extent of the damage.
4. Notify your distributor to inspect the merchandise within 15 days of delivery.

### D. CONCEALED DAMAGE

1. If damage is noticed after the equipment is unpacked, notify the distributor immediately and ask for an inspection.
2. Save the packing materials until inspection is complete.
3. Unless these conditions are met, your claim will probably be rejected by the distributor.

### E. CLAIMS

Satisfaction is between Manitowoc and its distributor to:

1. Arrange to have repairs made, or
2. Replace the merchandise.

## MODEL NUMBER DESCRIPTION

F\*+290#- or H\*+310#-

F = Floor Model Dispenser

H = Hotel/Motel Dispenser

\* = Denotes the style of actuator lever

### F Models

T — For self-serve or two-hand operation (see Fig. 1)

S — For glass actuated one-hand operation (see Fig. 1)

### H Models

P — Push button actuated

K — Room key actuated

C — Coin actuated

+ = Model vintage starting with letter A

To change with any major design changes

290 or 310 = Model number

# = Model variations — Customer options starts with B

- = Cabinet finish

S — Stainless Steel

F — Fawn

### Fig. 1

Model FXX290\*

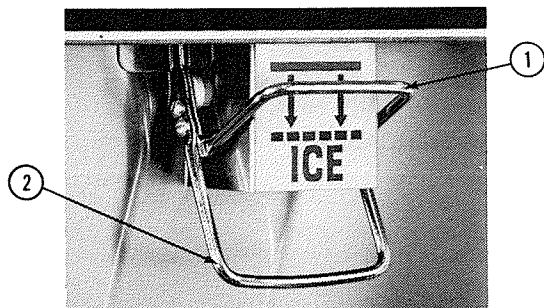

1 Actuating Arm — Two Hand  
2 Actuating Arm — Glass Fill

This dispenser has a dual purpose actuating lever.

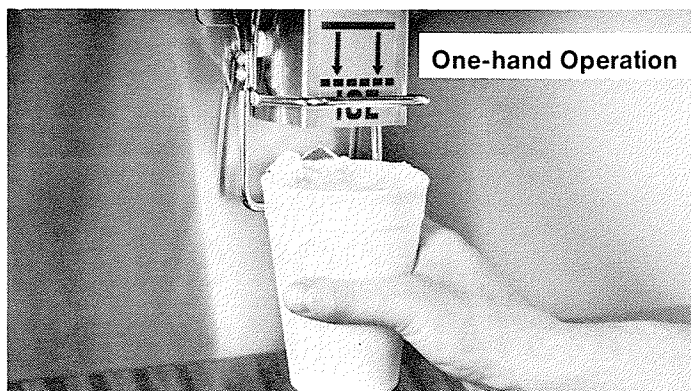

### Two-hand Operation

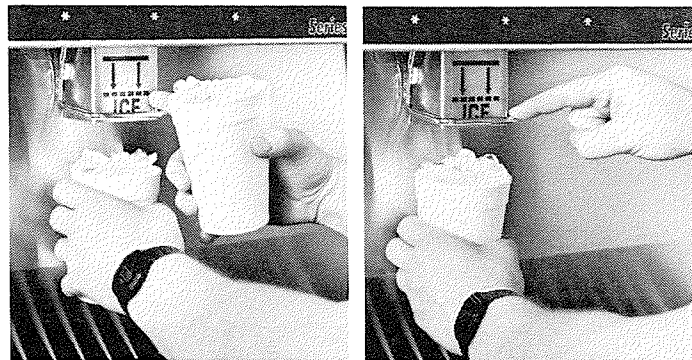

For the easiest two-hand operation, remove the one-hand actuating lever. This is accomplished by removing the four screws which secure the one-hand actuating lever to the two-hand actuating lever.

## DISPENSER INSTALLATION

We strongly recommend that the installation and "start and inspect procedure" be performed by a trained and competent technician.

### GENERAL

These dispensers are designed to dispense both Manitowoc "dice" and "half dice" ice.

These dispensers may be used in conjunction with a Manitowoc Series 200, 400, or 600 model ice machine and be filled automatically.

There is approximately a 10½" clearance height at ice discharge. When used, there is approximately an 8¼" clearance height at soda valves on the F\*+290. The H\*+300 will accept an 18" high by 11" wide ice bucket.

The F\*+290 dispenser will accept up to six NSF approved or listed drink-dispensing valves. A pattern for drilling mounting holes in the front door panel can be made from the valve.

### WATER VALVE OPERATION

Single hand operation:

Push glass against lower lever.

Two-hand operation:

Hold glass under valve and press on upper lever with other hand.

**IMPORTANT: For use in a self-service application, the lower lever must be cut off to meet N.S.F. requirements.**

### LOCATION

These dispensers are not designed for outdoor installations or installations where temperatures drop below +40°F or rise above +110°F. For best performance, select a location away from radiators, ovens, refrigeration condensers, direct sunlight and other sources of heat. Allow a minimum of five inches clearance around the dispenser for air circulation.

**Fig. 3**

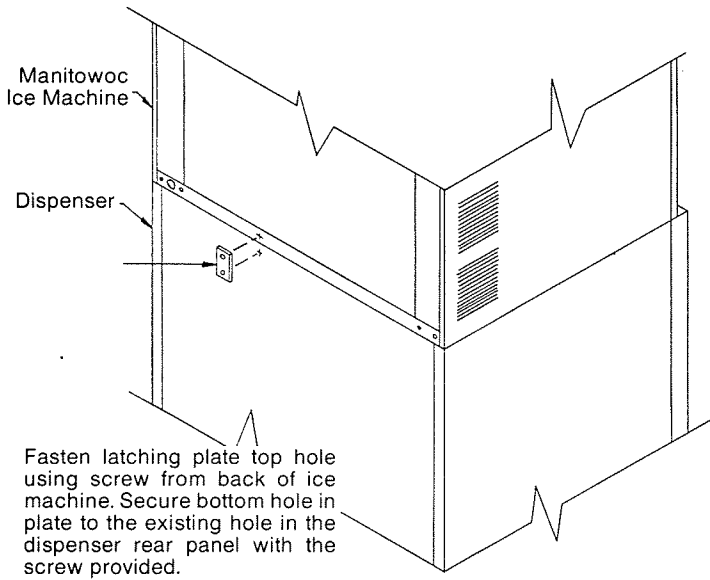

**Fig. 4**

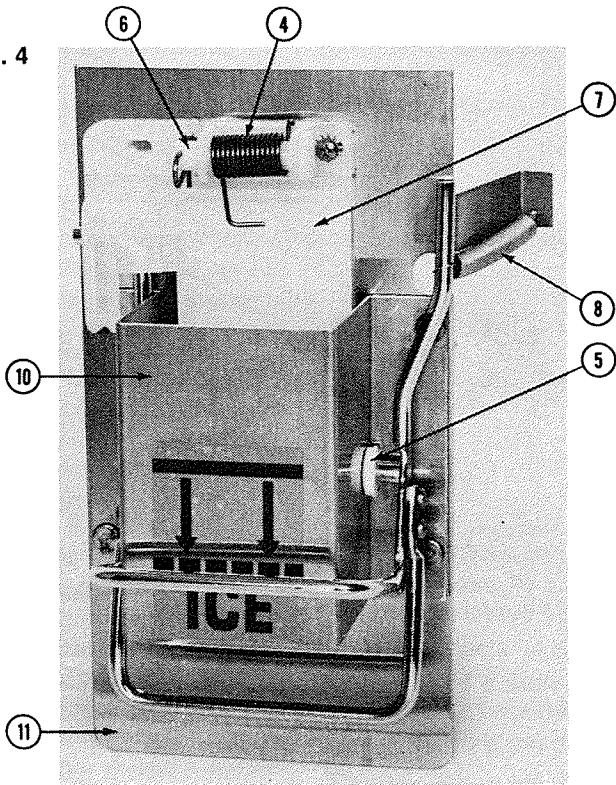

- 4 Spring
- 5 Bearing — 3/8" OD x 5/16" Thick
- 6 Hinge Pin
- 7 Living Hinge
- 8 Return Spring
- 9 Ice Chute Insert (not shown)
- 10 Ice Chute Weldment
- 11 Ice Delivery Mtg. Plate
- 12 Wire Grille

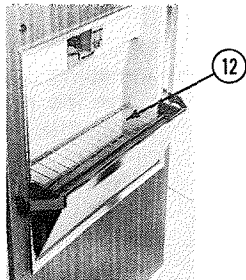

**SERIAL NUMBER AND ELECTRICAL DATA**

A serial plate with the serial number and electrical data is located on the rear of the dispenser. Another serial plate is also located behind the front door so that this can be read when the dispenser rear is not accessible.

**OPERATION PRINCIPLES**

This dispenser's electric motor is coupled directly to a right-angle gear box that drives through a 3/8" pitch positive displacement belt, the dispensing auger, and an agitator auger. The dispensing auger turns at approximately 35 revolutions per minute, and the agitator turns at approximately 17 revolutions per minute (see Fig. 5).

The dispenser motor is activated by an ice delivery switch located in a switch control box enclosure behind the upper front door of the dispenser. The ice delivery switch is closed by the ice delivery actuator lever (290) or push button switch (310), which is activated by the customer or attendant when ice is required ( see Fig. 6). This switch controls a mercury contactor that controls power to the dispenser motor (see Fig. 7).

**Fig. 5**

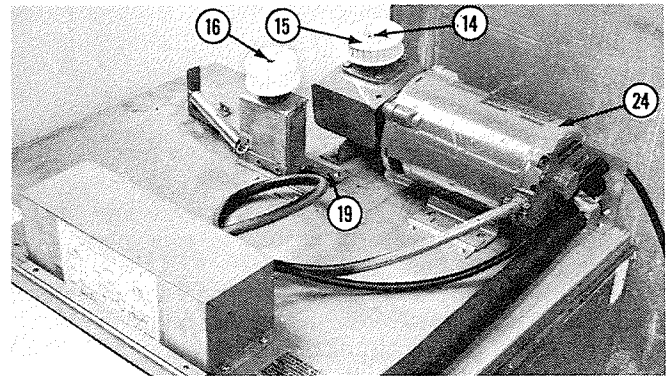

- 13 Positive Drive Belt (not shown)
- 14 Key Stock
- 15 Small Drive Pulley Assy. w/Keyway
- 16 Washer — 1 3/8" OD
- 17 Belt Tightener Wheel
- 18 Belt Tensioner Mounting Bracket Weldment
- 19 Tensioner Lock Bracket

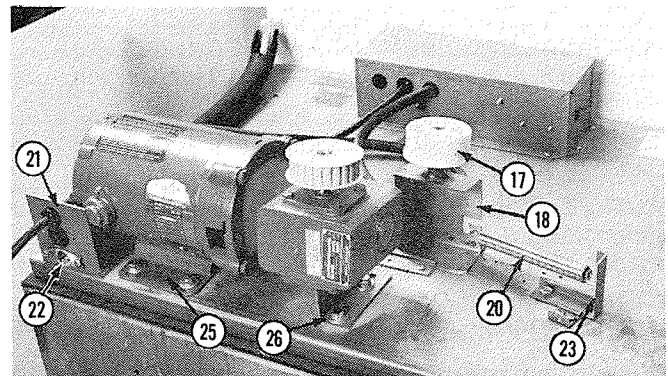

- 20 Belt Tightener Spring
- 21 Adapter Mounting Bracket
- 22 Drain Fitting Assembly
- 23 Bracket — Belt Tightener
- 24 Drive Motor/Gear Reducer
- 25 Gear Motor Lock Bracket
- 26 Gear Box Angle Bracket

**Fig. 6**

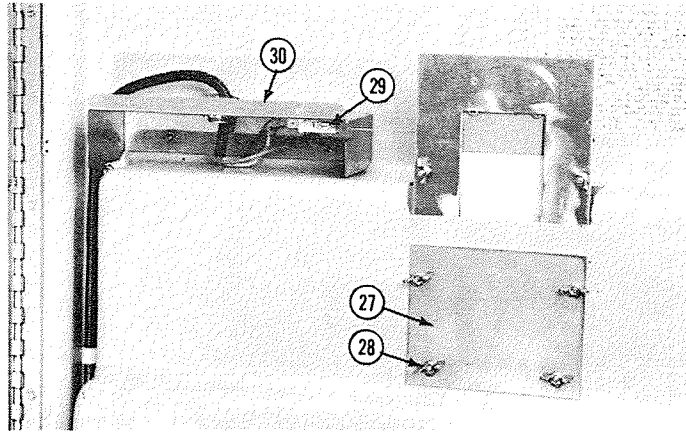

- 27 Ice Delivery Backing Plate
- 28 #8-32 Wing Nut
- 29 Ice Delivery Switch
- 30 Ice Delivery Switch Box
- 31 Cover — Ice Delivery Switch Box (not shown)

**Fig. 7**

**Dispenser Wiring Diagram  
With Electronic Start Winding Switch**

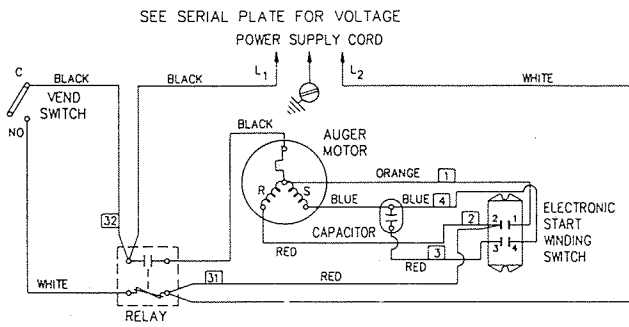

See next page for coin operated dispenser wiring diagram.

**Dispenser Wiring Diagram  
Without Electronic Start Winding Switch**

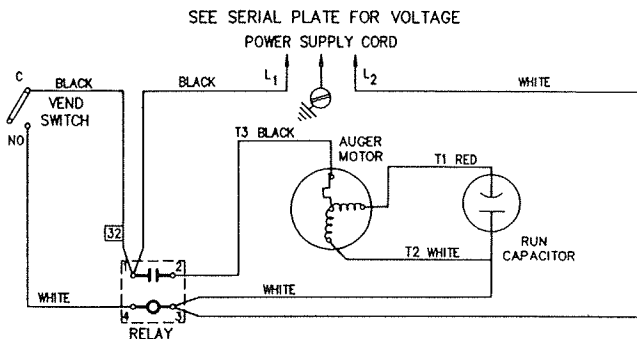

The ice delivery rate on the F\*+290 ranges from 2.7 oz./sec. to 1.0 oz./sec. On the 310 Series the rate ranges from 14 lbs./min. to 3.2 lbs./min., depending on cube size and bin fullness.

**CLEANING INSTRUCTIONS**

1. Remove all ice from storage bin before beginning to clean dispenser.
2. Remove power cord plug from the wall outlet.
3. Open the front door and remove thumbscrews from the bin front panel. Remove the bin front panel.
4. Remove ice deflector, dispensing auger, and agitating auger by removing thumbscrews. Once the brackets have been removed, the augers can be lifted up and out of the dispenser.
5. The false bottom can then be lifted out of the dispenser.
6. The inside of the bin, augers, bin front panel, upper bearing brackets, and false bottom can be cleaned with a solution of 3 oz. of Manitowoc Ice Machine Cleaner per gallon of water.
7. Rinse all parts with clear water before reassembly.
8. **F\*+290** — The ice dispensing area is removable from the door by disassembling four wing nuts on the inside of the door. The complete assembly can now be cleaned and sanitized with the same solution as used on the bin and internal parts.

**H\*+310** — The ice discharge area can be cleaned and sanitized on the door once the door is open. Use the same solution.

**WARNING:** Do not use metal scrapers or abrasives on the bin liner or plastic parts as these abrasives will destroy the smooth surfaces.

**SWITCH ADJUSTMENTS AND REPLACEMENT**

**CAUTION:** Before removing the switch control box cover, unplug the power cord from the wall outlet.

The actuator switch is located in a switch control box behind the front door (see Fig. 6).

**F\*+290** — The actuator switch is normally open, but closes as the actuator lever is pushed back or down. It can be adjusted by bending the flat or round arm on the switch. The switch should make contact just before the ice delivery door is completely open, and the switch contacts should open as the ice delivery door starts to close. The switch can be adjusted by listening for clicks as the switch is opened and closed.

**H\*+310** — No adjustment should be necessary.

**HC+330** — Coin and credit cancellation switch adjustment (see Fig. 14).

**Fig. 6**

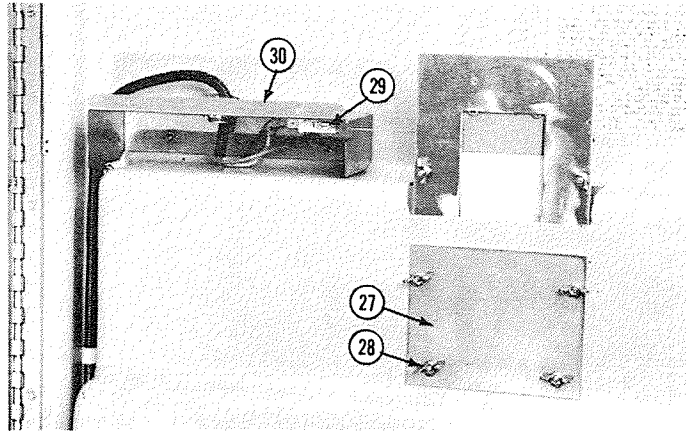

- 27 Ice Delivery Backing Plate
- 28 #8-32 Wing Nut
- 29 Ice Delivery Switch
- 30 Ice Delivery Switch Box
- 31 Cover — Ice Delivery Switch Box (not shown)

**Fig. 7**

**Dispenser Wiring Diagram With Electronic Start Winding Switch**

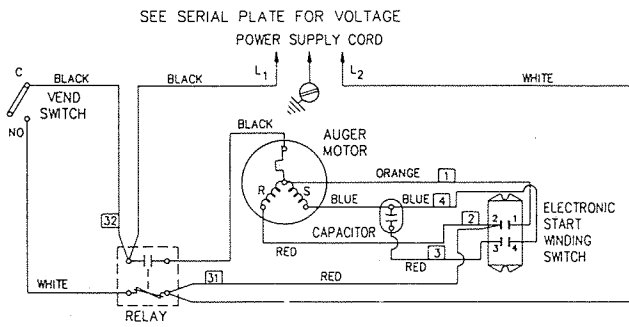

See next page for coin operated dispenser wiring diagram.

**Dispenser Wiring Diagram Without Electronic Start Winding Switch**

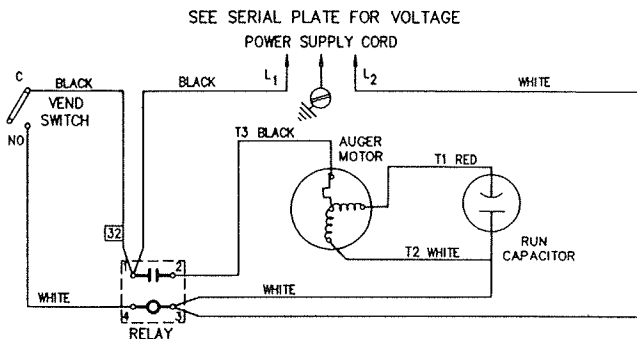

The ice delivery rate on the F\*+290 ranges from 2.7 oz./sec. to 1.0 oz./sec. On the 310 Series the rate ranges from 14 lbs./min. to 3.2 lbs./min., depending on cube size and bin fullness.

**CLEANING INSTRUCTIONS**

1. Remove all ice from storage bin before beginning to clean dispenser.
2. Remove power cord plug from the wall outlet.
3. Open the front door and remove thumbscrews from the bin front panel. Remove the bin front panel.
4. Remove ice deflector, dispensing auger, and agitating auger by removing thumbscrews. Once the brackets have been removed, the augers can be lifted up and out of the dispenser.
5. The false bottom can then be lifted out of the dispenser.
6. The inside of the bin, augers, bin front panel, upper bearing brackets, and false bottom can be cleaned with a solution of 3 oz. of Manitowoc Ice Machine Cleaner per gallon of water.
7. Rinse all parts with clear water before reassembly.
8. **F\*+290** — The ice dispensing area is removable from the door by disassembling four wing nuts on the inside of the door. The complete assembly can now be cleaned and sanitized with the same solution as used on the bin and internal parts.

**H\*+310** — The ice discharge area can be cleaned and sanitized on the door once the door is open. Use the same solution.

**WARNING:** Do not use metal scrapers or abrasives on the bin liner or plastic parts as these abrasives will destroy the smooth surfaces.

**SWITCH ADJUSTMENTS AND REPLACEMENT**

**CAUTION:** Before removing the switch control box cover, unplug the power cord from the wall outlet.

The actuator switch is located in a switch control box behind the front door (see Fig. 6).

**F\*+290** — The actuator switch is normally open, but closes as the actuator lever is pushed back or down. It can be adjusted by bending the flat or round arm on the switch. The switch should make contact just before the ice delivery door is completely open, and the switch contacts should open as the ice delivery door starts to close. The switch can be adjusted by listening for clicks as the switch is opened and closed.

**H\*+310** — No adjustment should be necessary.

**HC+330** — Coin and credit cancellation switch adjustment (see Fig. 14).

Coin Operated Dispenser Wiring Diagram

SEE SERIAL PLATE FOR VOLTAGE

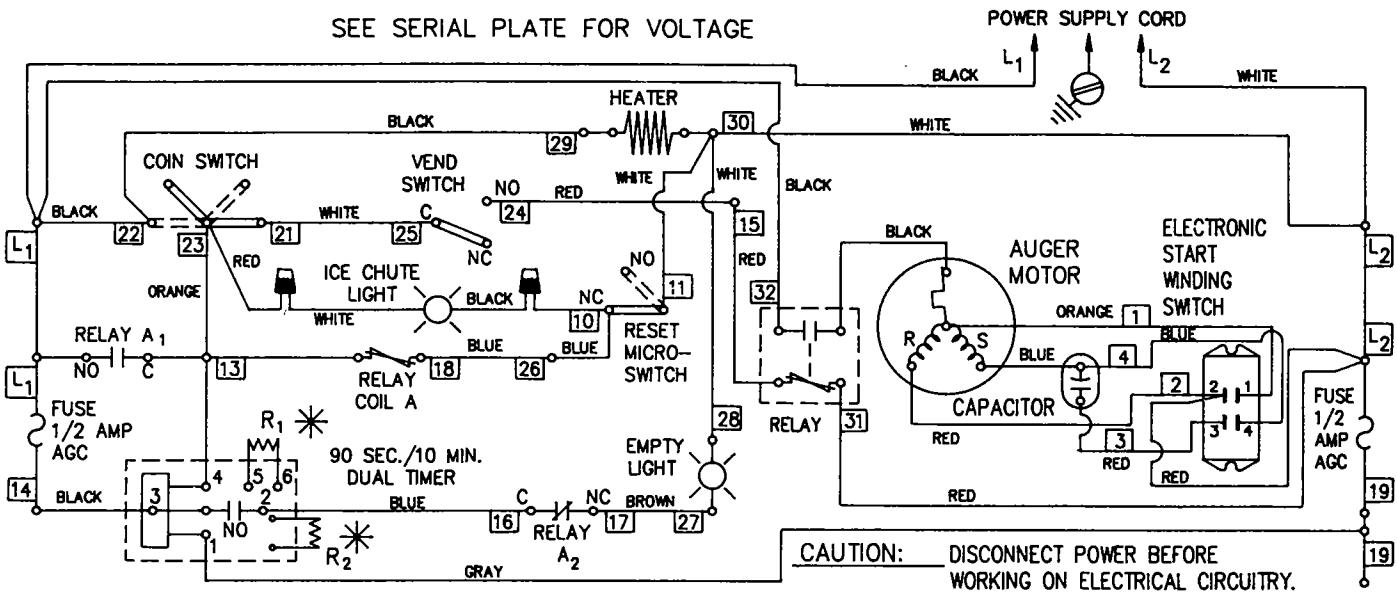

**CAUTION:** Before cleaning or performing maintenance on this dispenser pull the power cord plug from the wall outlet.

**NOTE:** Refer to page 5 for motor wiring without Electronic Start Winding Switch.

**SEQUENCE OF OPERATION**

1. Insert designated coin(s) and push lever into unit as far as it will go. Release thereafter.

**NOTE:** The push lever must be fully pulled out for the dispenser to operate.

2. This energizes the timer and the relay.

3. When ice button switch is activated, the auger motor is energized and ice is augered into the ice chute.

4. After the ice chute has been filled, the ice is then dispensed into a bucket below by pulling the chute forward.

5. The operation of the ice chute activates a microswitch, which in turn cancels the coin and the credit.

6. The dispenser is ready to receive a new coin.

7. If the dispenser is near empty and dispensing goes beyond 90 seconds, the dual timer activates an "empty" light indicating that the unit is in a replenishing mode for 10 or more minutes.

8. This light will light up as soon as operation 5 is completed. The microswitch, when operated by the ice chute, drops out the circuit board relay and the N.C. contacts complete a circuit for the "empty" light to light up.

9. **NOTE:** Even though the empty light is on, a coin will be accepted and ice may be dispensed for 90 seconds or more (no automatic cutoff). One may be at risk of getting only a limited amount of ice.

10. After 10 minutes, the dual timer opens its contact and the "empty" light is deactivated.



Fig. 8

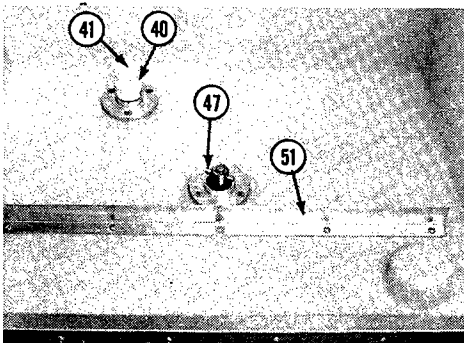
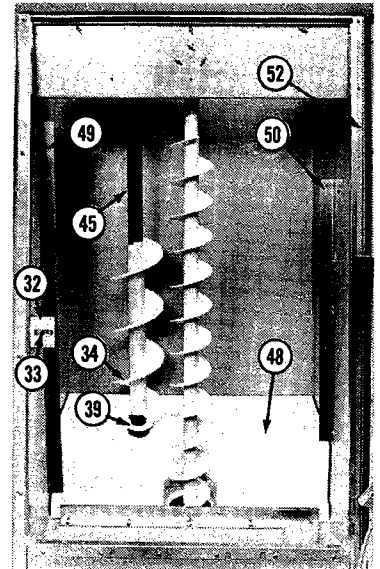
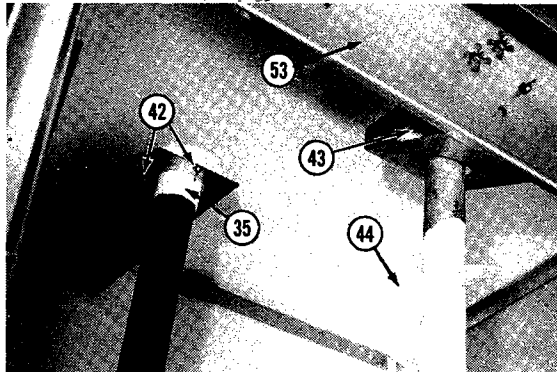
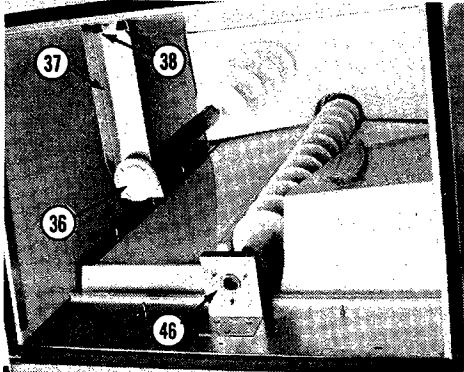

- 32 Door Lock Bracket
- 33 Cage Nut
- 34 Auger — 6" OD
- 35 Upper Bearing Coupling
- 36 Agitator Bearing
- 37 Agitation Auger Mounting Bracket Weldment
- 38 Thumbscrew — Plastic
- 39 Agitator Shaft Washer
- 40 Lower Bearing Coupling
- 41 ¼-20 x 1" Full Thread Machine Screw
- 42 Thumbscrew #8 x ½" Type A
- 43 Auger Bearing
- 44 4" OD Auger Weldment
- 45 Agitator Shaft Weldment
- 46 Auger Bearing Bracket Weldment
- 47 Pin
- 48 Liner Bottom Funnel
- 49 Left Hand Access Door Mounting Bracket
- 50 Right Hand Access Door Mounting Bracket
- 51 Access Door Base Bracket
- 52 Access Door Retainer Bracket
- 53 Upper Liner Bracket

### AUGER AND AGITATOR DRIVE ASSEMBLY REMOVAL

1. Empty ice from dispenser.
2. Unplug the dispenser's power cord from the wall outlet.
3. Remove rear access panel.
4. Remove the ice machine's front panel. After removing the front panel, shut off power to ice machine by using ice machine's on-off switch.
5. Open the front door on the dispenser and remove the thumbscrews in the bin liner front. Then remove the bin liner front.
6. Remove the ice deflector and upper bearing supports for the auger and agitator by removing the thumbscrews which fasten the supports to the dispenser.
7. Lift the agitator and auger vertically off the drive shaft and out of the dispenser (see Fig. 8).
8. Lift the false bottom out of the dispenser.
9. The drive assembly is now accessible for bearing removal (see Bearing Removal).

### BELT TIGHTENING AND REPLACEMENT

**CAUTION:** Before tightening or replacing the belt, unplug the power cord from wall outlet.

The belt is held snug by an extension spring, see Fig. 5. This is accessible by removing the dispenser's rear panel. Access is also available from the dispenser's front by opening the front door. Access from the front can be improved by removing the hold-down fasteners for the electrical control box and moving the box to one side.

The belt can be replaced or loosened by cutting the plastic wire tie and pushing or pulling toward the front on the bracket belt tightener, Item 23, Fig. 5. When replacing the belt, be sure that all the slack in the belt is taken up between the auger and agitator pulley. Also, be sure that the belt tensioner mounting bracket, Item 18, Fig. 5, slides freely and if not, grease the dispenser base in this area to insure it will slide freely.

**Be sure the wedge is located under gear box (see Item 26, Fig. 9).**

Fig. 9

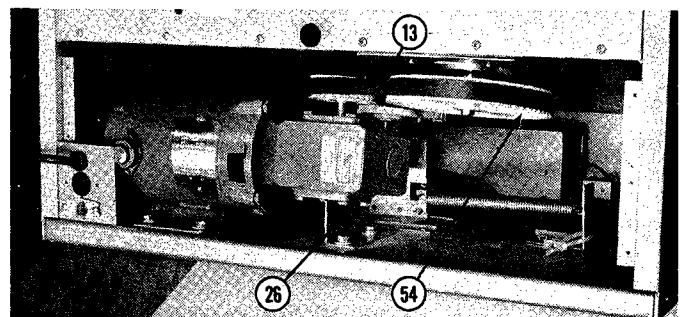

- 13 Positive Drive Belt
- 54 Large Pulley Assembly
- 26 Gear Box Angle Bracket

Fig. 10

- 47 Pin
- 55 Upper Drive Shaft Housing Assembly
- 56 Capscrew 1/4-20 x 2-1/16" #7 "Torque" Socket Head
- 57 1/4-20 x 5/8" Full Thread MS SS
- 58 Lower Drive Shaft/Housing Assembly
- 87 Gasket — Drive Shaft Coupling

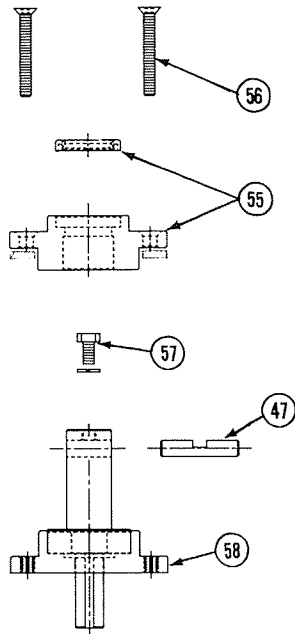

**NOTE:** Seal under bolt head with Silastic when replacing.

**BEARING ASSEMBLY REMOVAL**

1. Auger ice out of bin and then remove all remaining ice by hand.
2. Remove auger assembly (refer to Auger Assembly Removal).
3. Loosen belt by loosening belt tensioner and remove belt (refer to Belt Tightening and Replacement).
4. Remove lower bearing drive pin and the plastic drive coupling on the agitator drive shaft (see Fig. 10).
5. Remove the three bolts that hold the upper bearing housing assembly to the lower bearing housing assembly.  
**NOTE:** Bolt heads have been filled with silastic that should be cleaned out to insure good wrench engagement. Bolt heads take a #7 "Torque" driver.
6. Withdraw the three bolts from inside the bin and lift upper bearing assembly out of dispenser.
7. Withdraw the lower bearing assembly from the gear-and-motor compartment side.

**BEARING ASSEMBLY INSTALLATION**

1. Coat the sealing face of the upper bearing housing with RTV sealer or use drive shaft gasket (item 87, Fig. 10) to insure a water-tight seal between upper bearing housing and polyethylene bin liner. Then position bearing assembly in bottom of bin.  
**NOTE:** Seal under bolt heads with silastic also to insure a water-tight seal.
2. From inside the bin, insert the three mounting bolts through the upper bearing housing.
3. Install the lower bearing housing and shaft from the gear-and-motor drive compartment side.  
**NOTE:** Start all three bolts and tighten together to assure alignment. Tighten these bolts to 95 ± 5 in.-lbs. of torque.  
**NOTE:** Protect the water seal from damage during assembly and disassembly.
4. Insert the pin into the lower bearing drive shaft and insert bolt and washer. On the agitator drive shaft, the plastic drive coupling must be replaced.
5. Install the auger assembly (refer to Auger Assembly).

Fig. 11

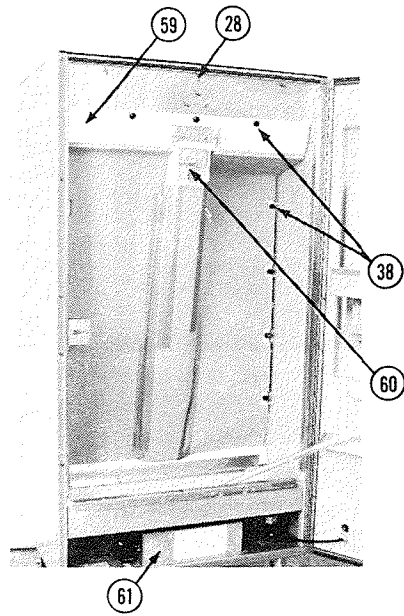

- 59 Access Door
- 60 Ice Restrictor Bracket
- 61 Junction Box Cover
- 38 Thumbscrew — Plastic
- 28 #8-32 Wing Nut

Fig. 12

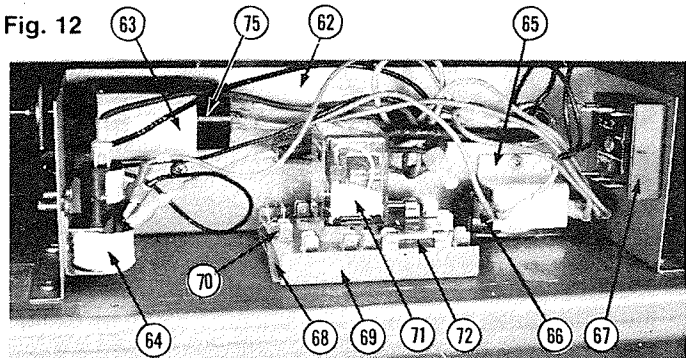

- 62 Junction Box
  - 63 Start Capacitor Bracket
  - 64 Mercury Relay
  - 65 Extruded Clamp
  - 66 Sinpac Switch
  - 75 Start Capacitor
- Coin Operated Machines Only**
- 67 Dual Delay Timer
  - 68 Mounting Channel
  - 69 Mylar Insulator
  - 70 Terminal Board
  - 71 Relay
  - 72 Fuse

**TROUBLESHOOTING  
ELECTRONIC START WINDING SWITCH**

Item 57 (Sinpac Switch), Fig. 12 (see Wiring Diagram, Fig. 7)

This device switches the start winding in and out of the circuit. This device replaces the mechanical/centrifugal switch on the 1/4 hp capacitor start motor. The electronic switch (Item 57) looks at the voltage wave that forms across the start winding. The wave form displays a slight dip, followed by a rise at the motor shaft speed where proper switch operation should occur (75-80% of synchronous speed).



The electronic switch will usually fail with the switch (Triac) in the open (nonconducting) mode. If the motor won't start and run, the switch can be tested by momentarily jumping the device across terminal number 3 and 2. This will engage the start winding.

If for some reason the electronic switch failed in the closed (conducting) mode, the motor overload should trip, and the device (Item 57) can be checked with an amp probe on the line coming off terminal number 2. The amp draw should decrease within one second, if start winding drops out.

**NOTE:** Anytime a problem occurs with the motor, the start capacitor (Item 75, Fig. 12) should be suspected and checked.

**Fig. 16 Model HC\*330\***

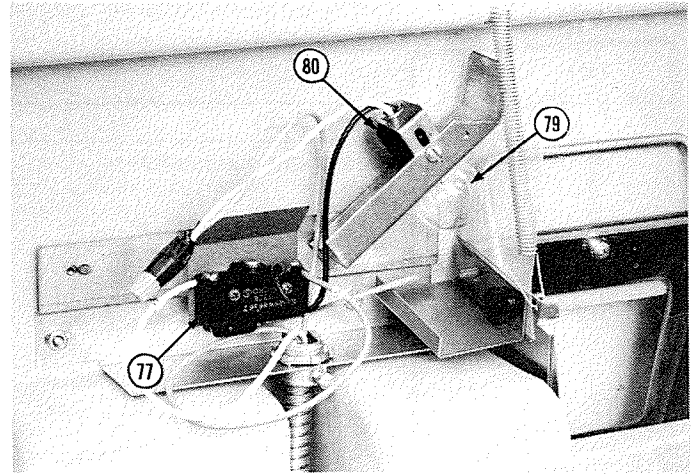

77 Microswitch — Credit Cancellation  
79 Light Bulb  
80 Socket

**Fig. 13**

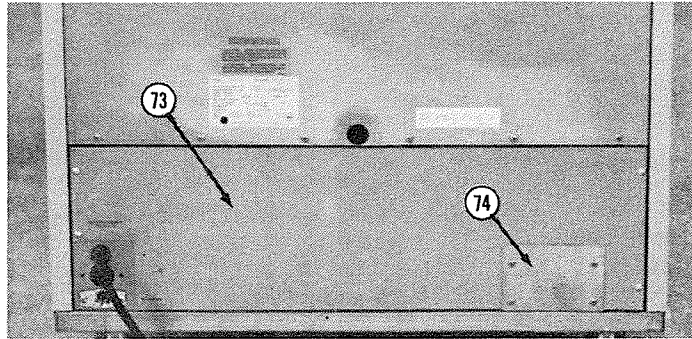

73 Lower Rear Access Panel  
74 Cover — Soda Line Entrance

**Fig. 17 Model HC\*330\***

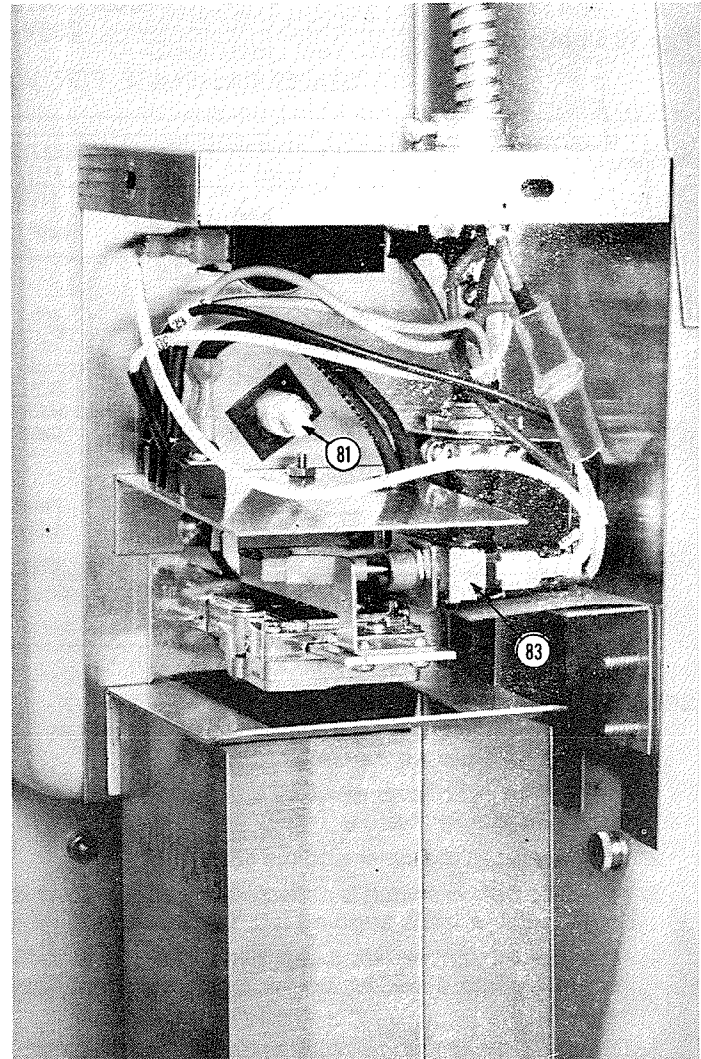

81 "Empty" Light  
83 Switch — Coin Mechanism

**Fig. 14 Model HC\*330\***

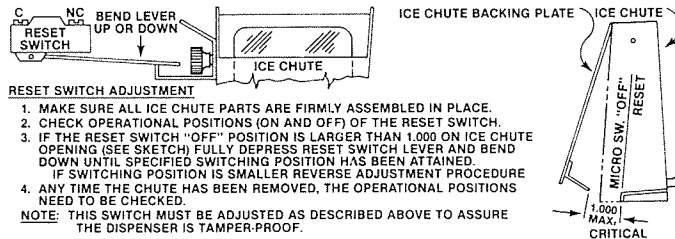

**Fig. 15 Model HC\*330\***

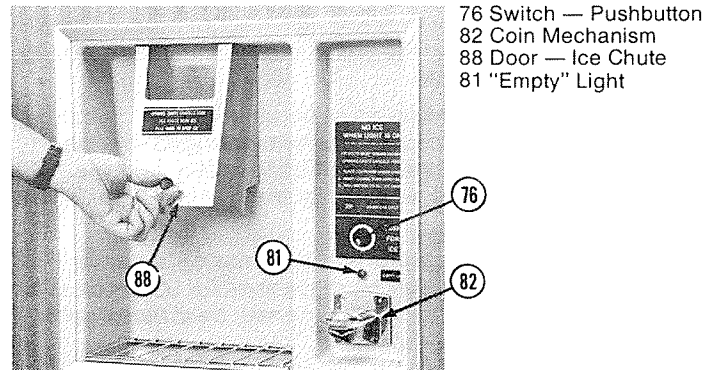

76 Switch — Pushbutton  
82 Coin Mechanism  
88 Door — Ice Chute  
81 "Empty" Light

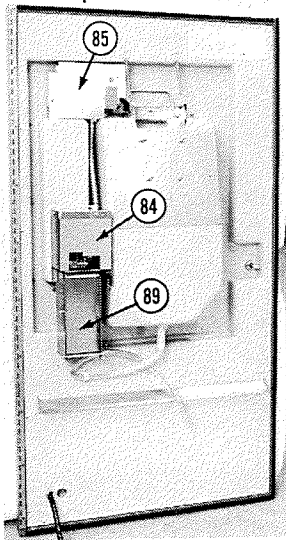

89 Coin Collection Box  
 84 Control Box, Coin Mechanism  
 85 Control Box, Coin Cancellation Switch

DISPENSER WIRING DIAGRAM

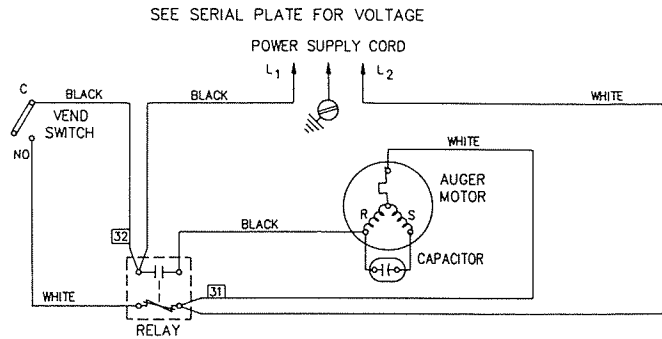
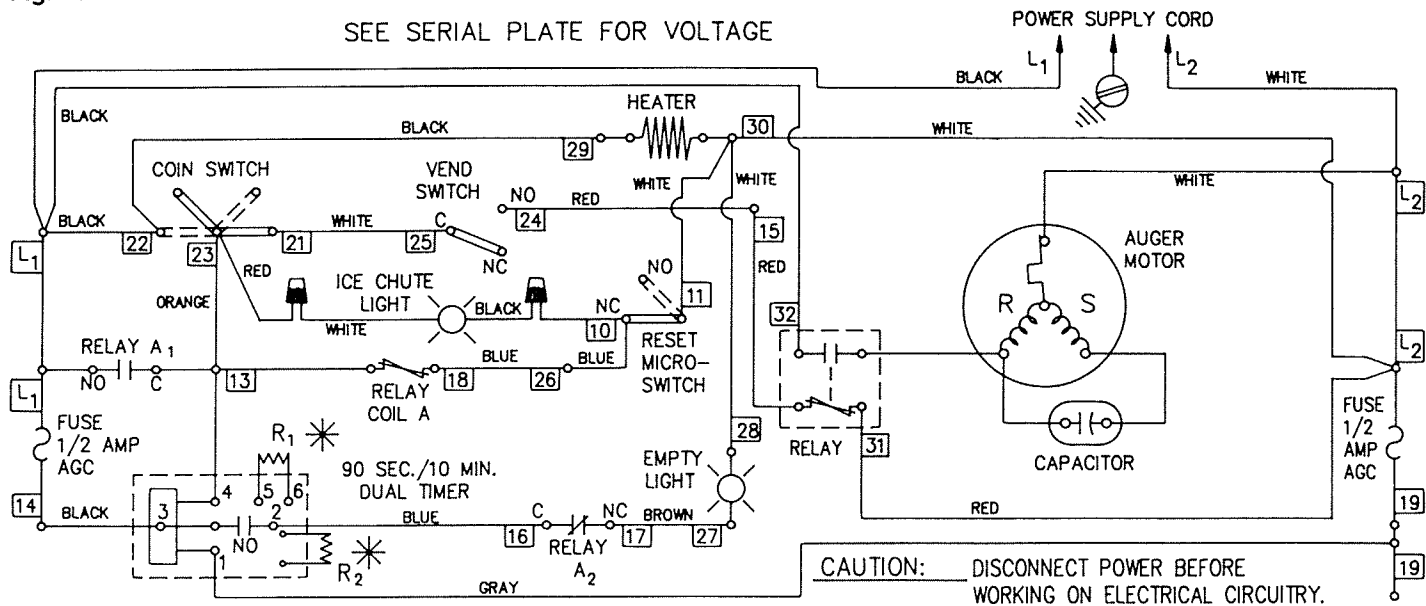

Fig. 19 Continued

Coin Operated Dispenser  
 230V — 50 HZ

SEE SERIAL PLATE FOR VOLTAGE



SEQUENCE OF OPERATION

1. Insert designated coin(s) and push lever into unit as far as it will go. Release thereafter.  
**NOTE:** The push lever must be fully pulled out for the dispenser to operate.
2. This energizes the timer and the relay.
3. When ice button switch is activated, the auger motor is energized and ice is augered into the ice chute.
4. After the ice chute has been filled, the ice is then dispensed into a bucket below by pulling the chute forward.
5. The operation of the ice chute activates a microswitch, which in turn cancels the coin and the credit.
6. The dispenser is ready to receive a new coin.
7. If the dispenser is near empty and dispensing goes beyond 90 seconds, the dual timer activates an "empty"

- light indicating that the unit is in a replenishing mode for 10 or more minutes.
8. This light will light up as soon as operation 5 is completed. The microswitch, when operated by the ice chute, drops out the circuit board relay and the N.C. contacts complete a circuit for the "empty" light to light up.
9. **NOTE:** Even though the empty light is on, a coin will be accepted and ice may be dispensed for 90 seconds or more (no automatic cutoff). One may be at risk of getting only a limited amount of ice.
10. After 10 minutes, the dual timer opens its contact and the "empty" light is deactivated.

**SERVICE**

**NOTE:** All service should be performed by an authorized Manitowoc Service Representative.

**TROUBLESHOOTING**

<b>TROUBLE</b>	<b>POSSIBLE CAUSE</b>	<b>CORRECTIVE MEASURES</b>
Dispenser will not dispense ice.	Bin empty.	Check ice machine operation.
	Power off.	Connect power cord. Check fuse.
	Large clusters of ice in bin.	Check and adjust ice bridging. Do not use bagged ice or be sure ice is broken up before putting in dispenser.
	Ice jammed in ice chute opening.	Check and clear opening.
	Defective Switch.	Check and adjust or replace.
	Drive belt broken or loose.	Tighten or replace.
	Drive motor defective.	Check or replace motor. Check start capacitor or replace. Check electronic motor starting switch.
Drive motor operates but auger doesn't turn.	Auger not properly seated on lower bearing drive shaft.	Check and reseal correctly, if necessary.
	Keys not in place on shafts.	Replace key.
	Belt loose. (If belt is loose, you will hear a ratcheting noise.)	Tighten tensioner. (See instructions.) Check to see wedge is located under gear box.
	Defective gear reducer.	Check and replace.
Motor running continuously.	Ice jammed in door opening.	Clear door. This can usually be done by dispensing a glass of ice.
	Switch.	Check adjustment or may have failed in the "on" position. Replace.

## Callout Reference Chart

1. Actuating Arm — Two Hand
2. Actuating Arm — Glass Fill
3. Latching Plate
4. Spring
5. Bearing 5/8" OD x 5/16" thick
6. Hinge Pin
7. Living Hinge
8. Return Spring
9. Ice Chute Insert
10. Ice Chute
11. Ice Delivery Mounting Plate
12. Wire Grille
13. Positive Drive Belt
14. Key Stock
15. Small Drive Pulley Assembly w/Keyway
16. Washer — 1 3/8" OD
17. Belt Tightener Wheel
18. Belt Tensioner Mounting Bracket Weldment
19. Tensioner Lock Bracket
20. Belt Tightener Spring
21. Adapter Mounting Bracket
22. Drain Fitting Assembly
23. Bracket — Belt Tightener
24. Drive Motor/Gear Reducer
25. Gear Motor Lock Bracket
26. Gear Box Angle Bracket
27. Ice Delivery Backing Plate
28. #8-32 Wing Nut
29. Ice Delivery Switch
30. Ice Delivery Switch Box
31. Cover — Ice Delivery Switch Box
32. Door Lock Bracket
33. Cage Nut
34. Auger — 6" OD
35. Upper Bearing Coupling
36. Agitator Bearing
37. Agitation Auger Mounting Bracket Weldment
38. Thumbscrew — Plastic
39. Agitator Shaft Washer
40. Lower Bearing Coupling
41. 1/4-20 x 1" Full Thread Machine Screw
42. Thumbscrew #8 x 1/2" Type A
43. Auger Bearing
44. 4" OD Auger Weldment
45. Agitator Shaft Weldment
46. Auger Bearing Bracket Weldment
47. Pin
48. Liner Bottom Funnel
49. Left Hand Access Door Mounting Bracket
50. Right Hand Access Door Mounting Bracket
51. Access Door Base Bracket
52. Access Door Retainer Bracket
53. Upper Liner Bracket
54. Large Pulley Assembly
55. Upper Drive Shaft Housing Assembly
56. Capscrew — 1/4-20 x 2" Hex Socket
57. 1/4-20x 5/8" Full Thread Machine Screw
58. Lower Drive Shaft/Housing Assembly
59. Access Door
60. Ice Restrictor Bracket
61. Junction Box Cover
62. Junction Box
63. Start Capacitor Bracket
64. Mercury Relay
65. Extruded Clamp
66. Sinpac Switch
67. Dual Delay Timer
68. Mounting Channel
69. Mylar Insulator
70. Terminal Board
71. Relay
72. Fuse
73. Lower Rear Access Panel
74. Cover — Soda Line Entrance
75. Start Capacitor
76. Switch — Pushbutton
77. Microswitch — Coin or Credit Cancellation
78. Terminal Board — Coin Unit
79. Light Bulb — Chute on Coin Model
80. Socket — Light Bulb — Coin Model
81. "Empty" Light — Coin Model
82. Coin Mechanism
83. Switch — Coin Mechanism
84. Control Box — Coin Mechanism
85. Control Box — Coin Cancellation Switch
86. Dual Timer — Coin Model
87. Gasket Drive Shaft Coupling
88. Door — Ice Chute
89. Coin Collection Box