



Easy Chopper™
55500-1 1/4" Cut
55500-2 3/8" Cut
55500-3 1/2" Cut
55500-4 1" Cut

OPERATING AND MAINTENANCE INSTRUCTIONS

Important

1. To get the best operation and life from your machine, please read and comply with these instructions.
2. Clean machine thoroughly before and after each use using cleaning instructions below.
3. Minimize the use of alkaline cleaners as they may cause pitting and dulling of the finish.

Safety Instructions

Remember that the blades are VERY SHARP; be careful when handling and operating the machine to keep hands away from the cutting edges.

Operation of Easy Chopper™

1. Place the chopper on a good firm work surface.
2. Your Easy Chopper™ produce chopper comes to you fully assembled.
3. Prepare the produce to be chopped (core, cut, slice, wedge to your specifications).
4. Lift HANDLE and place the produce on the blades.
5. Remove hand/fingers from the cutting area and with a strong, quick thrust, bring the PUSH BLOCK down to force the produce through the BLADES. Lift and repeat.
6. Clean the machine after chopping is completed using cleaning instructions below.

Caution: Do not attempt to chop produce larger than the opening in the BLADE HOLDER.

Note: Since BLADE AND HOLDER ASSEMBLES for different sized cuts are interchangeable, you may have more than one set available for use. BEFORE CHOPPING be sure that the PUSH BLOCK is the correct one to use for the cutting size desired. Gently lower the PUSH BLOCK onto the BLADE AND HOLDER ASSEMBLY to see that the PUSH BLOCK GUIDE rests on the BUMPERS. If it does not, something is wrong and must be corrected before chopping produce.

To cut 1/4", 1/2" use 1/4" PUSH BLOCK

To cut 3/8" use 3/8" PUSH BLOCK

To cut 1" use 55610 PUSH BLOCK

To Clean

1. Lift the HANDLE and PUSH BLOCK GUIDE off the GUIDE RODS.
2. Remove BUMPERS and lift the BLADE AND HOLDER ASSEMBLY off the GUIDE RODS.
3. Thoroughly wash the PUSH BLOCK GUIDE, the PUSH BLOCK, the BLADE AND HOLDER ASSEMBLY and the FRAME.
4. The PUSH BLOCK can be removed from the PUSH BLOCK GUIDE by removing THUMBSCREWS for further cleaning.
5. The BLADE AND HOLDER ASSEMBLY may also be totally disassembled for further cleaning as follows:
 - a) Remove THUMBSCREWS and the BLADE HOLDER PLATE.
 - b) Gently tap the BLADES and the BLADE SPACERS from the BLADE HOLDER.
6. To Reassemble:
 - a) Place the BLADE HOLDER on a table top with the BLADE SPACER pockets upward.
 - b) Insert the 4 BLADE SPACERS with their slots toward the inner opening of the BLADE HOLDER.
 - c) Insert BLADES with sharp edge downward and slots upward.
 - d) Insert BLADES with sharp edge and slots downward.
 - e) Reposition the BLADE AND HOLDER ASSEMBLY and secure with THUMBSCREWS.
7. Reposition BLADE AND HOLDER assembly, the BUMPERS, the PUSH BLOCK, the PUSH BLOCK GUIDE and HANDLE on the FRAME.

Chopping Tips

Cut produce before chopping and place a cut surface against the BLADES. Onions and tomatoes dice best if cut from top to bottom. They may be cut in half, or if smaller dices are desired, they can be cut several times in this direction.

To Lubricate

When needed, lubricate the GUIDE RODS with Mineral Oil, Food Grade Grease, or rub them with Paraffin. DO NOT LUBRICATE WITH COOKING OIL – IT GETS STICKY!

TO REPLACE BLADES OR BLADE SPACERS

If necessary, the BLADES and/or BLADE SPACERS can be replaced. To do this, follow Instruction 5 of TO CLEAN.

55500 - () EASY CHOPPER

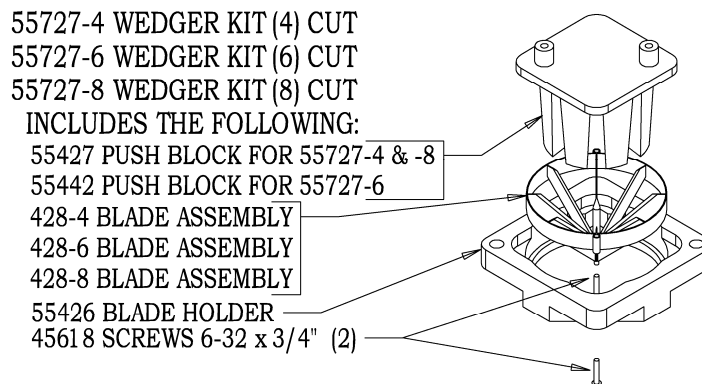
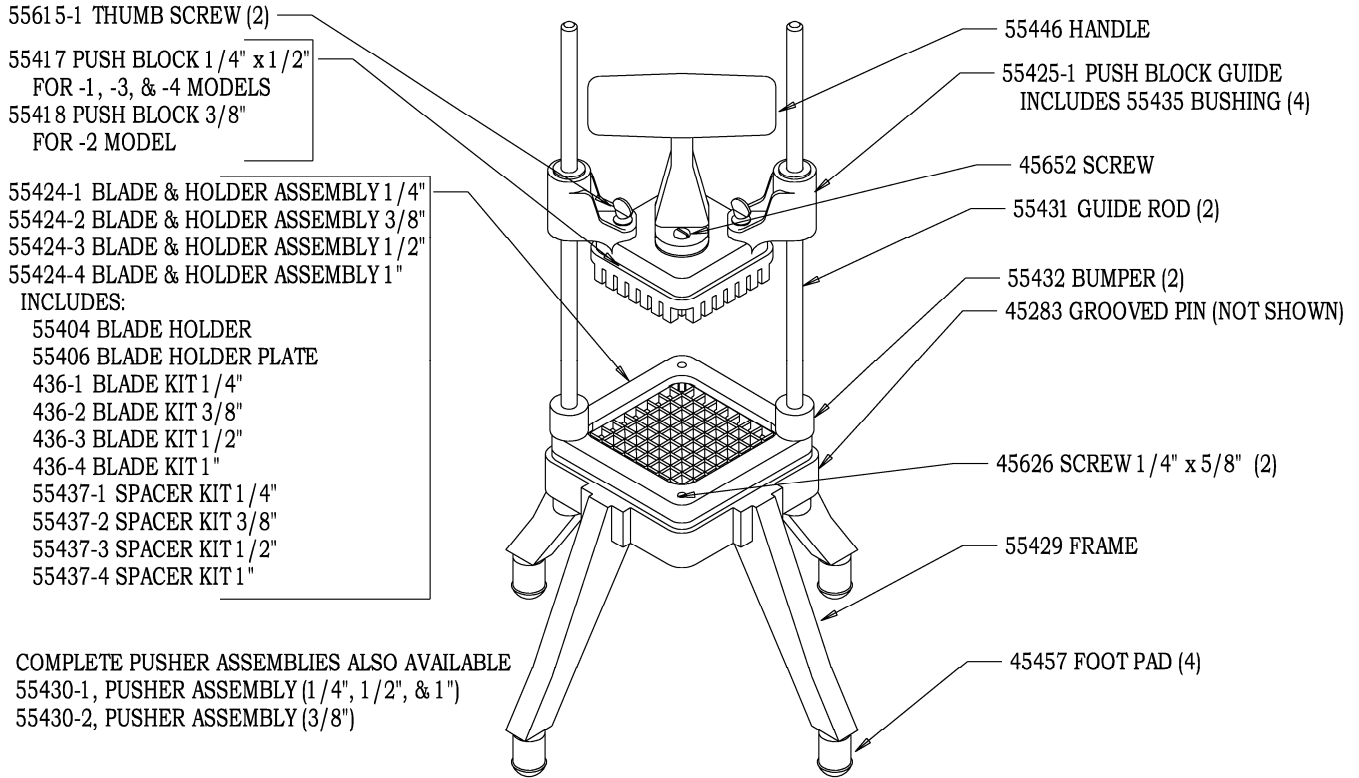

NEMCO FOOD EQUIPMENT

Phone: (419) 542-7751

301 Meuse Argonne, Hicksville, OH 43526

Fax: (419) 542-6690 Toll free: 1-800-782-6761

www.nemcofoodequip.com

46021

6-21-2011