



**HOT DOG MERCHANDISER
Model Series: 6550-()**

OPERATING INSTRUCTIONS

Thank-you for purchasing this hot dog merchandiser. Before operating this unit, read the following operating and safety instructions. Save these instructions.

WARNING: ELECTRIC SHOCK, FIRE OR BURN INJURIES CAN OCCUR IF THIS EQUIPMENT IS NOT USED PROPERLY.

To reduce the risk of injury:

- Plug into grounded electrical outlets only.
- Use only on flat, level surfaces.
- Unplug warmer and let cool before cleaning or moving.
- Unplug warmer when not in use.
- **Do not immerse in water.**
- **Do not spray with water and do not clean with a water jet.**
- Handle hot water carefully.
- Do not operate without water in the well.

Function and Purpose –THIS UNIT IS DESIGNED TO OPERATE WITH WATER IN THE WELL. WET OPERATION IS REQUIRED TO MAINTAIN SAFE FOOD ZONE TEMPERATURES (NSF), FOR MORE EVEN HEAT DISTRIBUTION, LOWER OPERATING COSTS AND LONGER TROUBLE FREE SERVICE. FOOD PANS MUST BE COVERED TO MAINTAIN TEMPERATURE WHEN FOOD IS NOT BEING SERVED.

Operations:

1. Place the unit on a flat stable surface.
2. Fill the stainless steel well with approximately 1 inch or 4 quarts of water. Do not allow water level to go higher than this. The food warmer will work most efficiently when used with water.

Warning
Electric Shock Hazard

Keep water level at or below soup turines. If the water level is too high, water may overflow when the food containers are inserted. The overflow could enter the electrical compartment and may cause a short circuit or electric shock.

3. Plug cord into a grounded electrical outlet.
4. Preheat the water in the well by covering the well with an empty food container or cover and set heat control knob to the maximum heat setting for the recommended time listed below.
 - 15 minutes if well was filled with HOT water.
 - 25 minutes if well was filled with COLD water.
5. Place stainless steel container of food into unit. Cover inset with lid. To prevent spills, do not overfill the food container.
6. For the function of hot food holding, set the heat control knob to the desired setting. Monitor food temperatures closely for food safety. The United States Public Health Service recommends that food be held at 150 to 160°F or above to help prevent the growth of organisms.

THE INSETS MUST BE COVERED TO MAINTAIN TEMPERATURES WHEN FOOD IS NOT BEING SERVED.

7. During normal operation for food holding periodically remove container and check water level. Add hot water if necessary. Stir occasionally.

Warning
Burn Hazard

Hot water and steam in the well can burn the skin. Use protective gloves, mitts or potholders when removing food container or cover. Hot food and water can also cause burns. Handle food carefully.

TROUBLESHOOTING

Won't Heat	Check that unit is plugged in
	Check that thermostat is turned to desired heat setting
	Check that well has correct amount of water
Product Cold/Not to Temperature	Adjust thermostat to increase temperature.(See Item 6 under "Operation")
Product too Hot	Adjust thermostat to decrease temperature.(See Item 6 under "Operation")
Unit Blows Fuse or Circuit Breaker	Check to make sure circuit is not overloaded.

Cleaning: To maintain appearance and increase the service life, the unit should be cleaned at least daily.

1. Before cleaning or moving unplug the unit and let it cool completely.
2. Carefully empty the hot water bath from the stainless steel well.
3. Wipe the entire stainless steel well interior with a clean damp cloth.
4. If soap or chemical cleaners are used, be sure they are completely rinsed away with clear water, immediately after cleansing. Chemical residue could damage unit.
5. DO NOT USE STEEL WOOL – USE NYLON PADS.
6. TO REMOVE SCALE, USE 1 tsp. WHITE VINEGAR TO 1 CUP OF WATER, LET STAND, RINSE, REPEAT IF NECESSARY.

WARNING

THIS APPLIANCE MUST BE GROUNDED. ELECTRICAL SHOCK CAN OCCUR IF APPLIANCE IS NOT GROUNDED.

REPAIR: TO AVOID SERIOUS INJURY OR DAMAGE, DO NOT REPAIR THE UNIT OR REPLACE A DAMAGED POWER CORD YOURSELF. REPAIRS MUST BE COORDINATED THROUGH NEMCO FOOD EQUIPMENT
301 MEUSE ARGONNE
HICKSVILLE, OH 43526
419-542-7751

DO NOT PUT FOOD PRODUCT DIRECTLY INTO THE WELL IN UNIT
FOOD MUST ALWAYS BE PLACED IN AN INSET.
DO NOT IMMERSE UNIT IN ANY LIQUID OR SPRAY UNIT TO CLEAN

THE USE OF WATER IN THE WELL IS REQUIRED TO MAINTAIN SAFE FOOD TEMPERATURES!

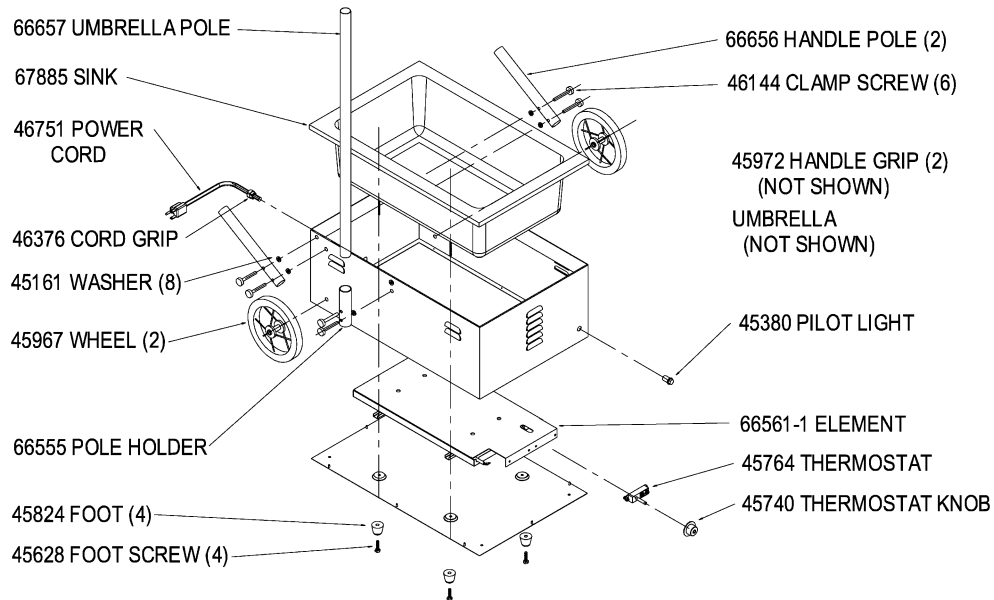

NEMCO FOOD EQUIPMENT 301 Meuse Argonne, Hicksville, OH 43526
 1-800-782-6761 Toll Free 419-542-6690 Fax
www.nemcofoodequip.com



46577
 3/31/2011