



77316-[] SPADEWELL

INSTALLATION INSTRUCTIONS

INTRODUCTION

1. Please read instructions before STARTING.
2. **IMPORTANT NOTICE:** This unit is not intended to be mounted in the ** Food Zone or the sink compartment.
3. It is important to follow and adhere to all plumbing codes. Use only Food Grade sealants or caulks. Areas indicated are required by NSF to maintain Certification.
4. This Spadewell will clean ice cream spades or scoops, maintain cleanliness, and prevent cross-contamination of food products during the serving process.
5. Clean machine thoroughly before and after all uses.

INSTALLATION

1. Determine the approximate location for the Spadewell to be installed. Note: It is best to be located near the ice cream freezer or worktable. Please keep in mind the IMPORTANT NOTICE above.
2. Level the well for proper drainage. Hold in place. Use as a template - mark the hole locations on the mounting surface. **SEE FIG 1**

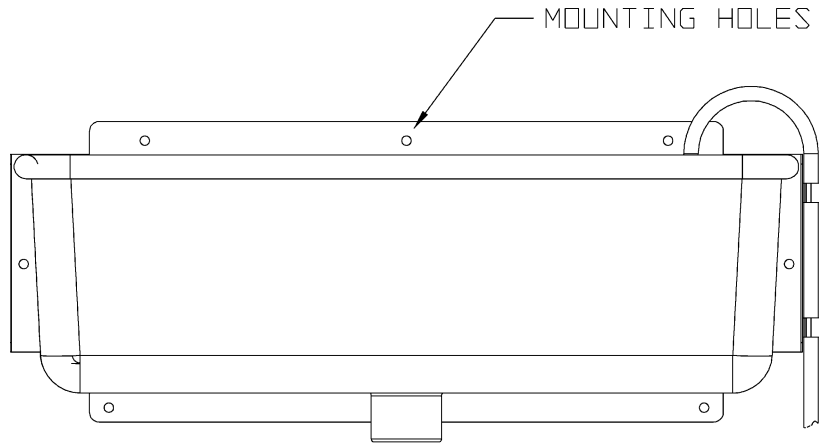

FIG1

3. Drill a pilot hole in the marked location. Note it may be necessary to center punch the location before drilling.
4. Apply Food Grade caulk to mounting bracket, full bead on all mounting surfaces. **SEE FIG 2**
5. Drive the mounting screws through the mounting holes in the Spadewell and into the mounting surface of the ice cream freezer or worktable. **SEE FIG 2 Note: Re-level well as required.**
6. Apply Food grade sealant to the seam between the top flange and mounting bracket. **SEE FIG 2**
7. Install drain (provided) using Food Grade sealant or caulk. **SEE FIG 2**

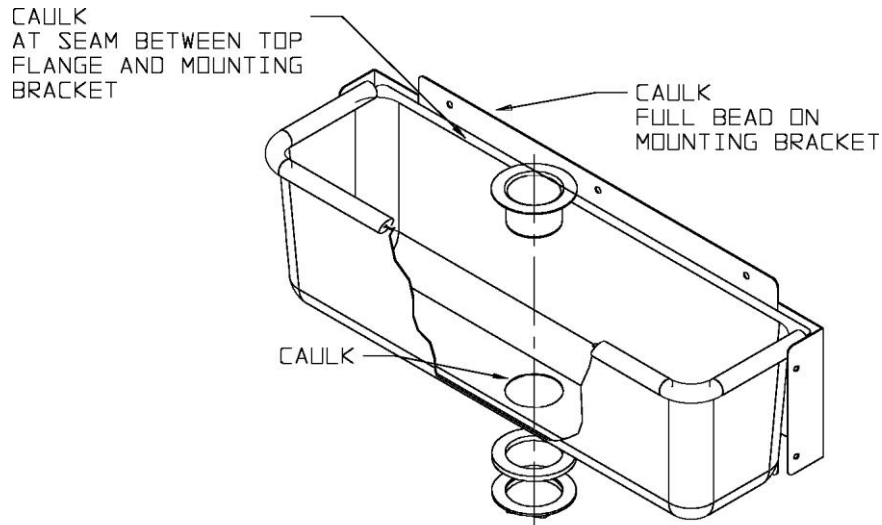
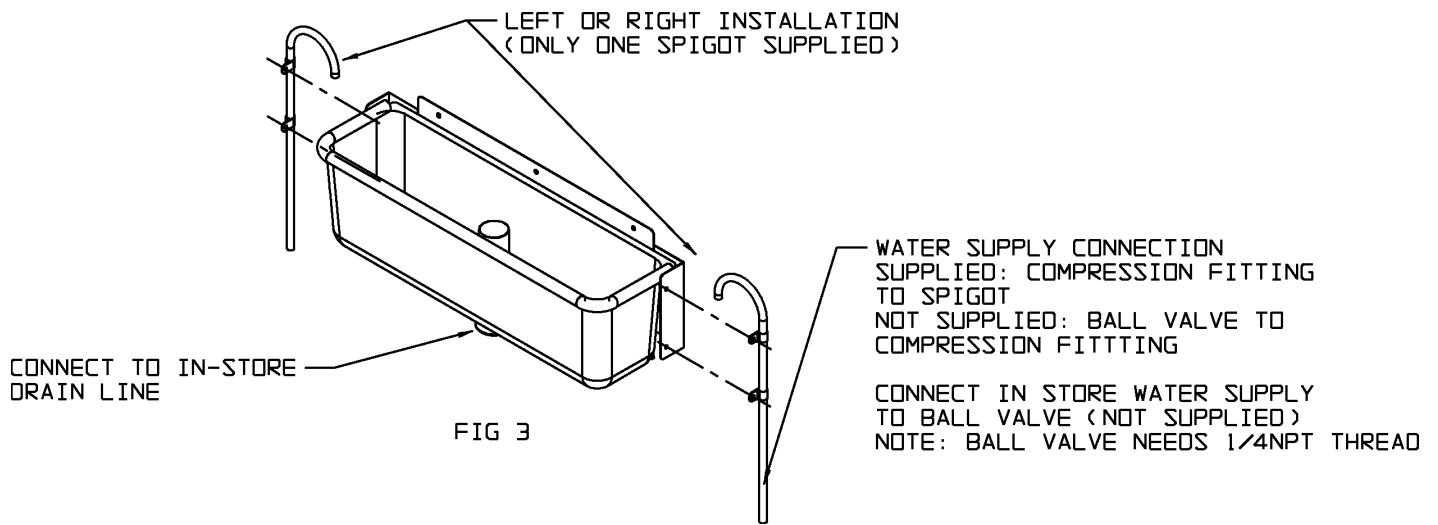

FIG 2

8. Locate the spigot into the clamps provided. Loosen nuts - slide spigot in - retighten clamps. **Note the spigot can be mounted in either the left or the right side. SEE FIG 3**



9. Shut off Main Water Supply.
10. Assemble compression fitting to Spadewell spigot. Then plumb into water supply line. Compression fitting has 1/4NPT thread.
11. Connect Spadewell drain to drain line in store.
12. Turn Main Water Supply Line on and check for leaks.
13. Place divider into well and position bumper onto rim
14. Clean unit. Wipe excess sealant or caulk that may have spread out during installation.
15. Turn on water - adjust for proper flow - Unit is now ready for use.

77316-[]
SERVICE PARTS

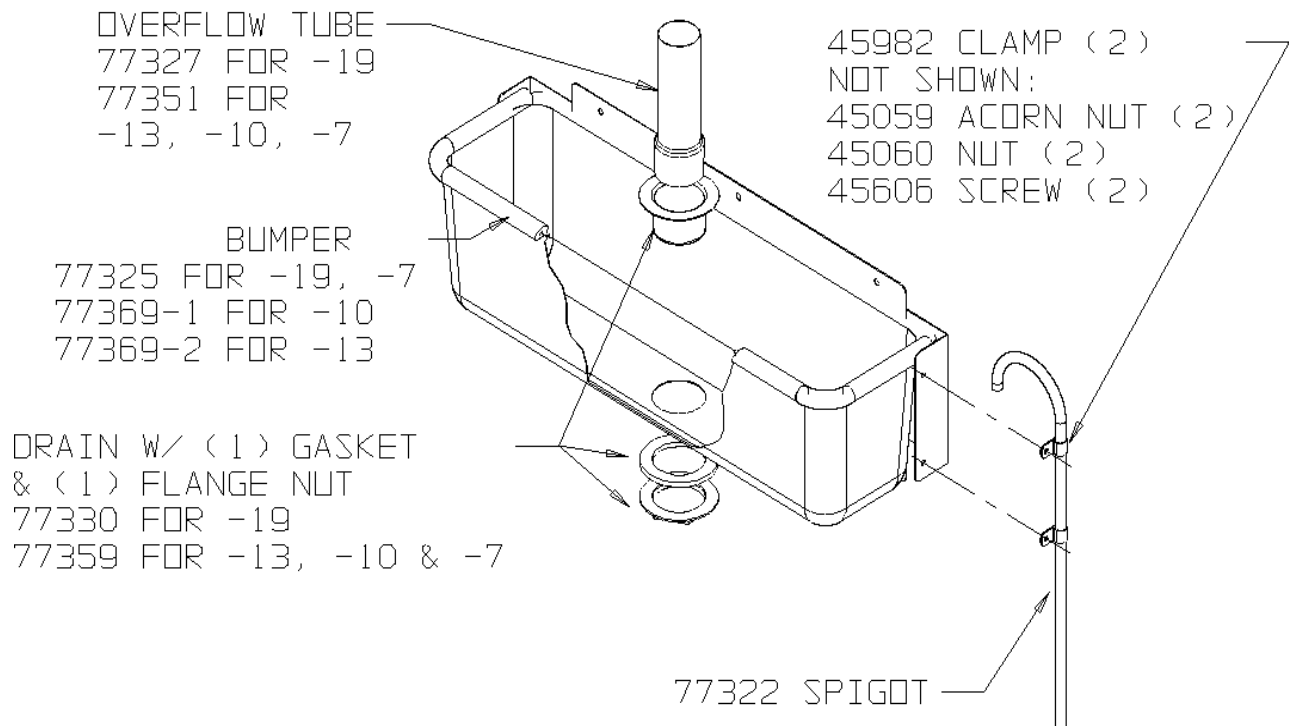

Model 77316-[]

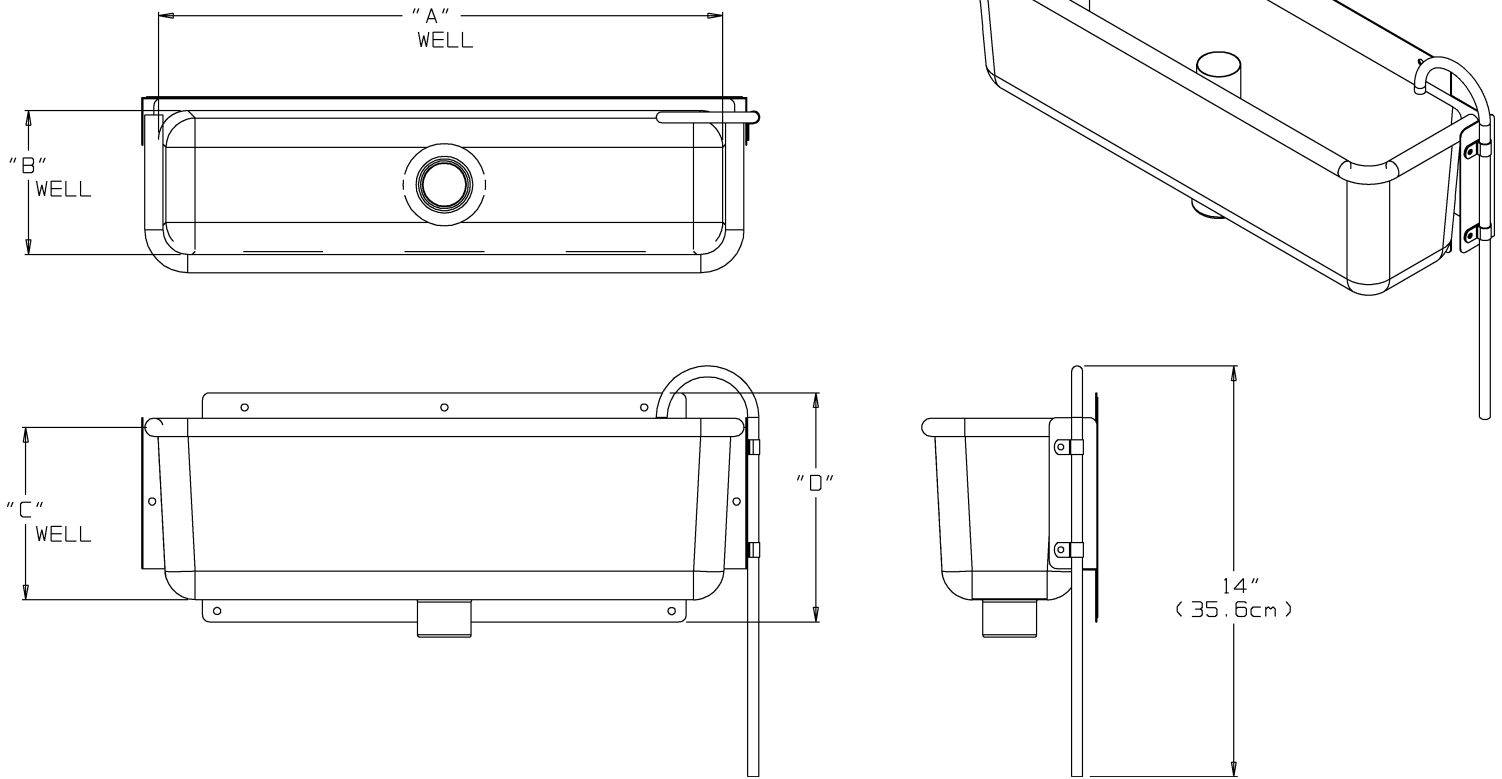

Specifications:

Model No	"A"	"B"	"C"	"D"	Ship Weight
77316 -7()	7"	6-1/4"	4"	5-7/8"	5 lbs./2.3Kg
77316 -10()	10-3/8"	5"	4"	5-7/8"	6 lbs./2.7Kg
77316 -13()	12-3/4"	5-1/4"	4"	5-7/8"	7 lbs./3.2Kg
77316 -19()	19-1/4"	6-7/8"	6"	7-7/8"	11.5 lbs./5.2Kg

NOTE: DIMENSIONS ARE APPROXIMATE

Typical Specifications

Spadewell Ice Cream Spade Cleaning Well has a stainless steel body and is equipped with a rubber bumper. Spadewell models are listed with the National Sanitation Foundation (NSF).

**** Food Zone:** *Equipment surfaces intended to be in direct contact with food and equipment surfaces that food or condensate may contact and then drain, drip, or splash back into food or onto surfaces that are intended to be in direct contact with food.*

For example: Directly installed within the ice cream cabinet is a food zone

(REF: NSF STD NSF/ANSI 170 - Glossary of food equipment Terminology, Section 3.223.2)



NEMCO Food Equipment, LTD
 301 Meuse Argonne
 Hicksville, OH 43526
 Phone 1-800-782-6761 Toll Free
 Fax 419-542-6690
www.nemcofoodequip.com

