



## Easy Slicer™ Vegetable Cutter

N55200AN	Adjustable Cut	N55200AN-1	3/16" Shredder
N55200AN-4	1/8" Fixed Cut	N55200AN-2	5/16" Shredder
N55200AN-6	3/16" Fixed Cut		
N55200AN-8	1/4" Fixed Cut		

### Operating and Maintenance Instructions

#### Important

1. To get the best operation and life from your machine, please read and comply with these instructions.
2. Clean machine thoroughly before and after each use using cleaning instructions below.
3. Minimize the use of alkaline cleaners as they may cause pitting and dulling of the finish.

#### Safety Instructions

1. **Remember the blades are VERY SHARP; be careful when handling and operating the machine to keep hands away from the blades.**
2. Never operate the machine without the GUARD and COVER PLATE in proper position. Always push produce to the BLADES with the PUSHER PLATE. Never push produce with the hand.

#### Preparation

1. Loosen screw in PUSH PLATE about 8 turns (or remove it completely)
2. Install PUSH PLATE in the grooves in the TROUGH AND LEG ASSEMBLY.
3. Place GUIDE under the head of the screw and tighten the screw.
4. If unit fails to operate properly when first used call NEMCO customer service at 1-800-782-6761

#### To Mount

1. Place the EASY SLICER on the work surface to establish a location that is convenient and comfortable for the operator. Draw an outline of the MOUNTING BASE on the work surface.
2. Remove the MOUNTING BASE from the EASY SLICER and place within the outline drawn on the work surface. Draw circles where the 4 holes are located and remove the MOUNTING BASE.
3. Drill ¼" (or slightly larger) holes in work surface where holes in MOUNTING BASE were located – 4 holes.
4. Secure the MOUNTING BASE to the work surface with screws provided.

**Note:** The LEG can be repositioned by removing the 4 cap screws and installing with the LEG positioned as desired. This feature permits mounting flexibility for convenience and for use of the EASY SLICER™ with a MOUNTING BASE that may already be installed for mounting other NEMCO machines.

#### To Operate

1. Slide the EASY SLICER™ into the MOUNTING BASE, with the extension containing the LOCKING SCREW going in last. Tighten the LOCKING SCREW to secure the machine.
2. If using the ADJUSTABLE SLICING UNIT, check slice thickness setting and adjust if necessary (see TO ADJUST).
3. Pull PUSHER HANDLE and raise COVER PLATE and place produce into the TROUGH.
4. Close COVER PLATE and gently push on PUSHER HANDLE KNOB while turning the HANDLE on the ROTARY CUTTING UNIT in a clockwise direction. Maintain uniform pressure on the PUSHER HANDLE.

#### To Adjust

1. The ADJUSTABLE SLICING UNIT is easily adjusted by holding the HANDLE stationary and by turning the ADJUSTING SCREW at the end of the ADJUSTING SHAFT ASSEMBLY.
2. The thickness of the slice is indicated by the alignment of the pin in the slot and the lines on the recessed portion of the MAIN SHAFT. These lines are 1/16" apart; so 2 lines = 2/16" or 1/8", 3 lines = 3/16", etc., up to ½".

#### Operating Tips

1. For slice uniformity, turn the ROTARY SLICING UNITS slower as the slice width increases. This will help assure that the produce is fully advanced to the ADJUSTING PLATE before the next BLADE begins to cut.
2. After placing produce in the TROUGH, turn the HANDLE about ¼ turn counter-clockwise before turning in the cutting direction. This will permit a "running start" as the blade makes its first cut. It will be easier and will provide more uniform slices.
3. Do not apply heavy pressure on the PUSHER HANDLE. It is unnecessary and will not improve the slicing or shredding action.
4. Do not force produce that is too large into the TROUGH. It will be difficult to push into the CUTTING BLADE and will result in poor uniformity of the cut.
5. Keep the BLADES sharp.

### **To Clean**

Minimize the use of alkaline cleansers to clean the machine. Such cleansers may cause pitting which could eventually impair cleaning and necessitate replacement of the machine.

The EASY SLICER™ can be washed as an assembled unit by loosening the LOCKING SCREW and removing the UNIT to a sink or dishwasher.

The EASY SLICER™ was designed for easy disassembly for cleaning as follows:

1. Turn SHAFT LOCK ASSEMBLY counter-clockwise to the stop and pull the ROTARY SLICING UNIT away from the TROUGH & LEG ASSEMBLY (this will slip out easily). BE CAREFUL OF THE SHARP BLADES!
2. Lift the GUARD off the TROUGH AND LEG ASSEMBLY.
3. Remove HINGE PIN and the COVER comes off.
4. Turn the PUSH ROD counter-clockwise to unthread it from the PUSH PLATE. This permits removal of the PUSH ROD and the PUSH PLATE.
5. Remove the LOCK PIN by pulling it to the left, and pull the SHAFT LOCK ASSEMBLY to remove it from the TROUGH & LEG ASSEMBLY.

NOTE: Periodically clean the shaft lock bore with (47945) BRASS BRUSH provided with the EASY SLICER to prevent the lock from becoming difficult to turn.

6. When desired, the unit can be further disassembled as follows:

- a) Loosen the thumbscrew to remove the ADJUSTING PLATE ASSEMBLY.
- b) Remove the nut by turning it counter-clockwise, to remove the CARRIER AND BLADE ASSEMBLY.
- c) Remove the screws to remove BLADES. NOTE: Mark the SCREWS so they can be put back in the same position to maintain a smooth surface on the other side of the BLADE CARRIER.
- d) Remove the corresponding screw by turning counter-clockwise to remove the GUIDE, the LEG or the HANDLE.

Wash with soap and water or mild detergent. Immediately after cleaning, reassemble by reversing the disassembly process described above. This will protect the blade and avoid the risk of losing any of the parts.

### **To Clean Shredder**

Follow instructions TO CLEAN (above) except remove the SHAFT by turning counter-clockwise and remove the screws to remove the BLADE.

### **To Clean Fixed Cut Assembly**

Follow instructions TO CLEAN (above) except remove the SHAFT by turning counter-clockwise and remove screws to remove BLADES.

**NOTE:** Mark the screws so they can be put back in the same position to maintain a smooth surface on the other side of the blade carrier.

### **To Sharpen Slicer Blades**

To prolong the sharpness of your BLADES, they can be honed as follows:

- 1) If the unit is adjustable, adjust to the maximum slice width (1/2").
- 2) Remove the ROTARY SLICING UNIT from the TROUGH AND LEG ASSEMBLY.
- 3) Use a fine honing stone (do not file) on the flat side of BLADE and, if needed, on the beveled side (be sure to maintain the original sharpening angles).

Send your BLADES to NEMCO for sharpening when BLADES are too dull to restore by honing, or when the honing has altered original bevels.

### **To Remove Blades**

SLICER BLADES: Remove the ROTARY SLICING UNIT from the machine as for cleaning and remove flat head screws to release BLADES.

SHREDDER BLADES: Remove SHAFT and screws by turning counter-clockwise.

### **To Change Accessories**

1. Turn SHAFT LOCK ASSEMBLY counter-clockwise to the stop and pull the ACCESSORIES from the TROUGH AND LEG ASSEMBLY.
2. Install the alternate ACCESSORY and turn the SHAFT LOCK clockwise to the stop.

### **To Lubricate**

Lubricate the following places with mineral oil or equivalent (do not use cooking oil – it becomes sticky):

Arms on PUSH PLATE (Top & Bottom)

Grooves in the TROUGH

Plastic Bearings in the TROUGH

Slots in the ADJUSTABLE SLICER SHAFT

Frequency of lubrication will vary with the amount of use and cleaning methods. Lubricate when needed.

### **Other Repairs**

Replacement of most parts or assemblies is simple and obvious. If other repair is needed, we recommend the unit be returned to NEMCO.



**NEMCO FOOD EQUIPMENT**

301 Meuse Argonne, Hicksville, OH 43526

Phone: (419) 542-7751

Fax: (419) 542-6690

Toll free: 1-800-782-6761

[www.nemcofoodequip.com](http://www.nemcofoodequip.com)

46016

9/8/04

# 55200AN - [ ] EASY SLICER

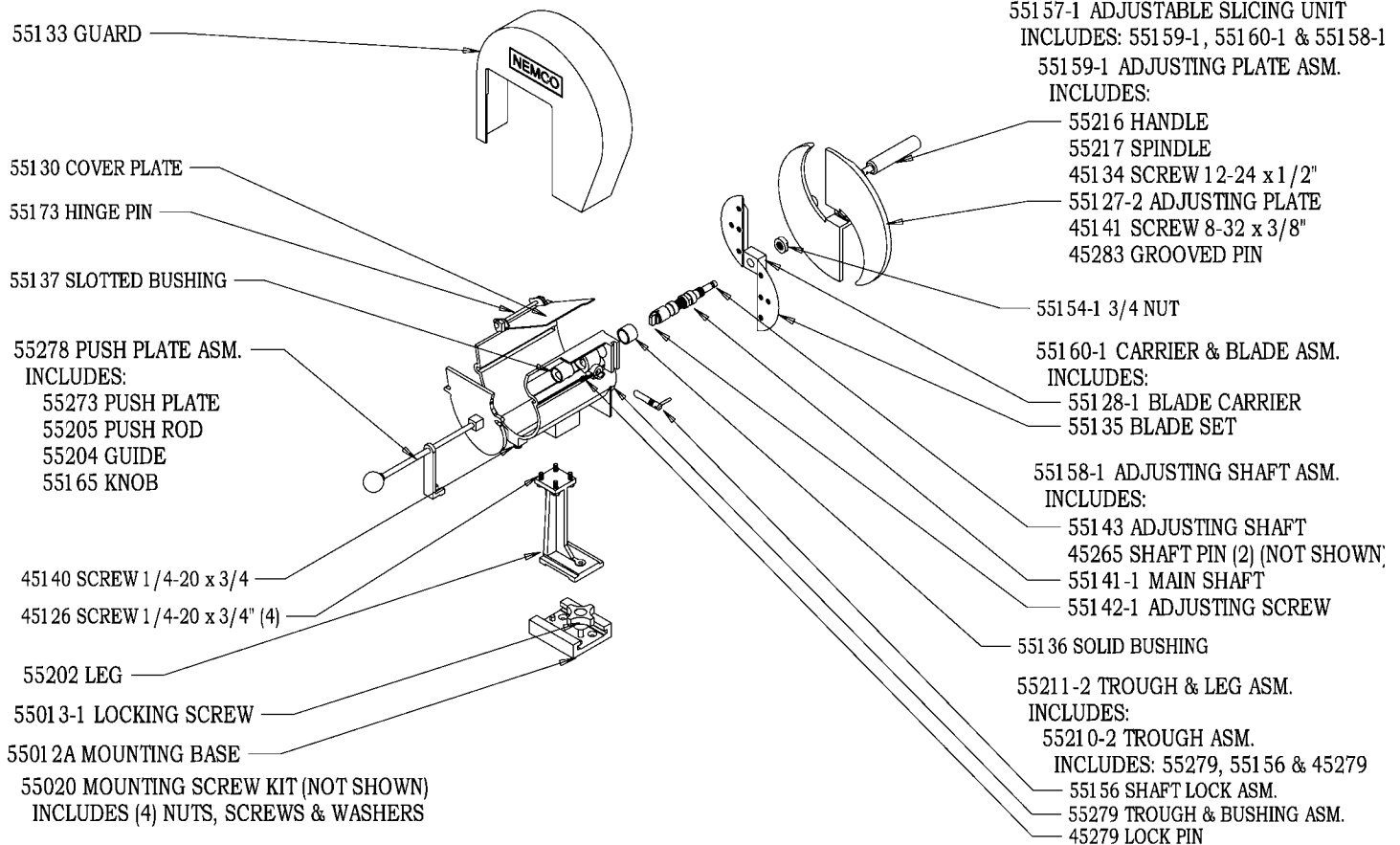

## 55263-\* SHREDDER PLATE ASSEMBLY (DASH NUMBER DETERMINED BY BLADE BELOW)

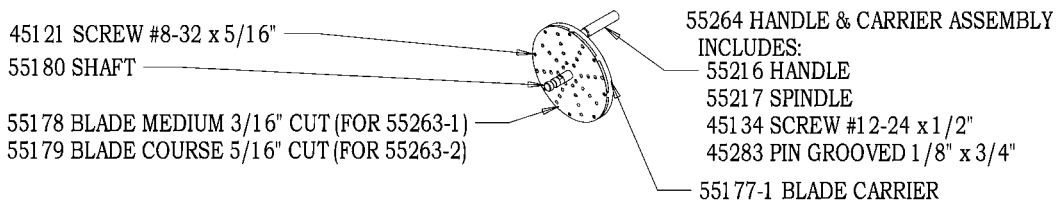

## 55261-\*N ROTARY SLICING UNIT (FIXED CUT) MODELS (DASH NUMBER DETERMINED BY FIXED PLATE BELOW)

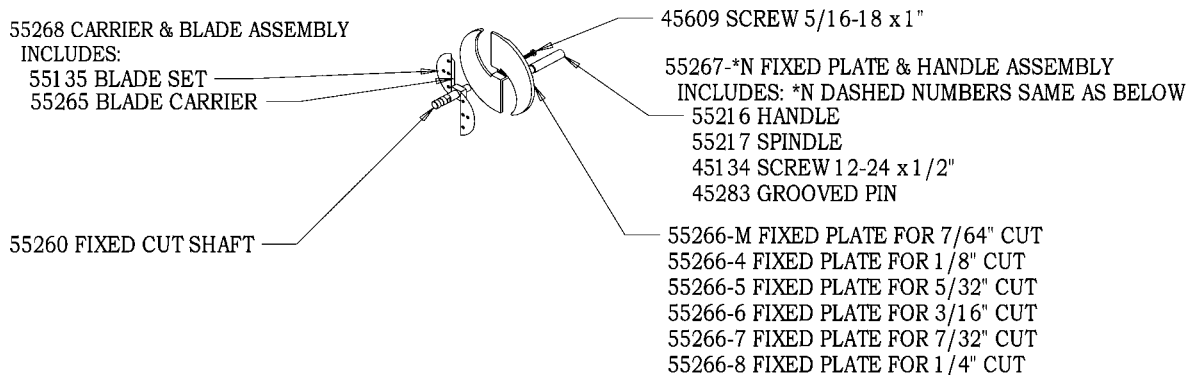

**NEMCO FOOD EQUIPMENT**

Phone: (419) 542-7751

301 Meuse Argonne, Hicksville, OH 43526

Fax: (419) 542-6690 Toll free: 1-800-782-6761

[www.nemcofoodequip.com](http://www.nemcofoodequip.com)

46016  
9/08/04