



AUTOMATIC
FOODSERVICE
EQUIPMENT

AUTOMATIC GAS BROILER
MODELS 732/735G, 532/535G, AND 522G - "B" Series

OWNER'S MANUAL

IMPORTANT: RETAIN THIS MANUAL IN A SAFE PLACE
FOR FUTURE REFERENCE.

FOR YOUR SAFETY:

Do not store or use gasoline or other flammable vapors or liquids in the vicinity of this or any other appliance.

WARNING: Improper installation, adjustment, alteration, maintenance can cause property damage, injury, or death. Read the installation, operating and maintenance instructions thoroughly before installing or servicing this equipment.

Broiler area must be kept free of combustible materials, and the flow of combustion and ventilation air must not be obstructed. Operating personnel must not perform any maintenance or repair functions. Contact your Nieco Authorized Dealer.

In a prominent location, post instructions to be followed in the event the user smells gas. This information shall be obtained by consulting your local gas supplier.

TABLE OF CONTENTS

A. General Information	3
Description	
B. Machine Installation	4
Pre-Installation	
Mounting	
Hood Requirements	
Clearance	
Gas Connection	
Electrical Connection	
Pre-Operation Check	
Gas Connectors and Restraining Device	
C. Operation	7
Controls and Indicators	
Gas System Controls	
Step-by-Step Lighting Procedure	
Shutdown Procedure	
Automatic Temperature Control	
D. Parts and Location	10
Exploded Drawings	
E. Assembly/Disassembly and Cleaning.....	19
F. Conveyor Belt Removal	22
G. Conveyor Belt Tension	23
Broil Belt Problems	
H. Troubleshooting Guide.....	24
I. Specifications	27
J. Wiring Diagrams.....	30

A. GENERAL INFORMATION

Model 732/735 Gas

Model 532/535 Gas



Model 522 Gas



DESCRIPTION

The Nieco Automatic Gas Broiler is a compact self-contained unit designed to broil hamburgers or other food products by use of a conveyerized cooking section. The Models 732/735, 532/535, and 522 are return flow units with a built-in heated meat holding section.

The broiler is divided into two sections. The top section uses a conveyor belt system to pass food through the cook zone, where infrared, convection and conduction heat is used to cook the product uniformly on both sides. After the product is cooked, it automatically slides into a heated holding section, where it can be kept until served.

The Model 732/735 uses 6 burners, 3 on top and 3 on the bottom. The 532/535 and 522 utilize 4 burners, 2 top and 2 bottom. The 522 is narrower than the 732/735 or 532/535.

B. INSTALLATION

PRE-INSTALLATION

Uncrate the broiler, and inspect for shipping damage. Contact the factory if there is obvious damage. Remove the tape securing the machine parts, and install the parts in their proper location. Refer to the Parts and Location section of this manual. If you find concealed damage to any part of this unit, contact your freight carrier immediately. The factory warranty does not cover freight damage.

MOUNTING

If the broiler was shipped with a tubular stand, refer to separate tubular stand assembly instructions.

Note: The four legs of the broiler stand are equipped with casters. Always set the brakes on the casters to prevent the broiler from shifting during operation or cleaning.

HOOD REQUIREMENTS

This appliance must be installed under a ventilation hood of adequate size and capacity (see chart).

Model	CFM	CMH
732/735	800	1360
532/535	600	1020
522	400	680

The hood should be at least 6" (152MM) larger in all dimensions than the appliance top, and be 12" to 18" (305MM - 457MM) above the top. Do not obstruct the flow of combustion and ventilation air. An adequate air supply must be available for safe and proper operation.

Note: See the National Fire Prevention Association booklet on ventilation of cooking equipment. Write to: NFPA, 470 Atlantic Ave., Boston, MA 02210. Local codes on venting must also be complied with.

CLEARANCE

For proper installation, the minimum clearance from combustible and non-combustible construction is 6" (152MM) from the back and 6" (152MM) from the front of the machine. Keep appliance area free from combustibles.

To facilitate disassembly and service of the unit a minimum of 24" (610MM) should be allowed on the control panel (right) side of the broiler, as well as in front of the broiler.

GAS CONNECTION

At rated BTU capacity, the gas supply should deliver a pressure of at least 6" water column at the broiler connection for natural gas, and 11" water column for propane gas. Incoming gas supply pressure must not exceed 14" water column for either type of gas.

The appliance was shipped from the factory ready for gas supply hook-up to the shutoff valve under the broiler. For disconnect, a manual valve must be located in the gas supply line upstream from the connector.

If the machine is installed on a moveable stand; (1) the installation shall be made with a connector that complies with the Standard for Connectors for Moveable Gas Appliances, ANSI Z21.69-1987, and Addenda, Z21.6a-1989, and a quick disconnect device that complies with the Standard for Quick-Disconnect Devices for Use With Gas Fuel, ANSI Z21.41-1989, and (2) adequate means must be provided to limit the movement of the appliance without depending on the connector and the quick-disconnect device or its associated piping to limit the appliance movement. (See figures on page 7.)

Note: Appliance installation must conform with all local codes, or in the absence of local codes, with the National Fuel Gas Code ANSI Z223.1-1988. Check all fittings for gas leaks, including pilot tubing and inlet connections as soon as the appliance is connected to the gas supply.

Note: This appliance and its individual shutoff valve must be disconnected from the gas supply piping system during any pressure testing of that system at test pressures in excess of 1/2 psig (3.45 kPa).

Note: This appliance must be isolated from the gas supply piping system by closing its individual manual shutoff valve during any pressure testing of the gas supply piping system at test pressures equal to or less than 1/2 psig (3.45 kPa).

In Canada, installation shall be in accordance with CAN/CGA-B149.1 Natural Gas or CAN/CGA-B149.2 Propane Gas, and local codes where applicable.

By public initiative, the State of California has adopted legislation (Proposition 65) which requires manufacturers of many types of products, including gas appliances, to warn consumers of their products that contain chemicals or produce substances listed by the State of California to either cause cancer, birth defects, or other reproductive harm.

WARNING: If not installed, operated, and maintained in accordance with the manufacturer's instructions, this product could expose you to substances in fuel, or from fuel combustion which can cause cancer, birth defects, or other reproductive harm.

ELECTRICAL CONNECTION

Power requirements are stated on the unit nameplate and must be connected accordingly. Before starting broiler, tighten all electrical connections in control box. An electrical diagram is located inside the control box.

Note: This appliance must be electrically grounded in accordance with local codes or in the absence of local codes, the National Electrical Code, ANSI/NFPA No. 70-1990. In Canada, in accordance with the Canadian Electrical Code CSA 22.1 part 1, or local codes.

WARNING: This appliance should be connected with a four-pronged grounding plug for your protection against shock hazard. Be sure to plug directly into a properly grounded four-prong receptacle. Do not cut or remove grounding prong from plug.

Note: This appliance cannot be safely operated in the event of a power failure. No attempt should be made to operate during a power failure. Disconnect power supply before servicing.

PRE-OPERATION CHECK

Be sure that all parts are installed in the proper location. Refer to **OPERATION** section for lighting procedure. Start broiler and test for proper operation.

INSTALLING GAS APPLIANCE CONNECTORS AND FLEXIBLE GAS LINES CORRECTLY

For safety in the kitchen area, and to insure maximum service life, it is vitally important to correctly install connectors.

In order to avoid sharp kinks or excessive bends that could have a damaging effect on the connector, it may be necessary to attach pipe elbows in order to bring the connector into its proper plane. For easy movement of the appliance, the connector should be installed with a "lazy" loop for minimum tension.

Note: Gas appliances should be disconnected prior to maximum movement. (Minimal movement is possible to connect hose.)

WRONG

Avoid sharp bends and kinks when pulling equipment away from wall.

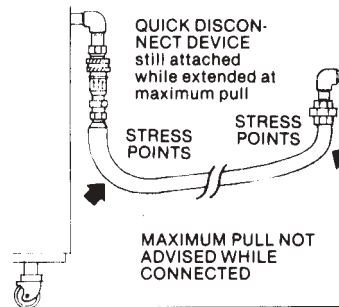

RIGHT

Minimum pull of equipment is permissible for accessibility to quick disconnect device.

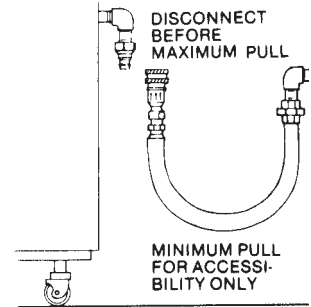

RESTRAINING DEVICE INSTALLATION AND USE

This high strength restrainer is to be used with all moveable (castered) appliances. It fully complies with American Gas Association requirements. References: Z21.69, Z83.11, and Z21.41 with current revisions. Installation is quick and positive. In Canada, device is in accordance with CAN 1-6.9-M70 Quick Disconnect Devices for use with gas fuel, and CAN 1-6.10-88 metal connectors for gas appliances.

Correct length for any appliance is simply a matter of loosening two adjuster clips (1) and re-tightening. (3" to 6" shorter than appliance connector is desired length.)

Restrainer is made of heavy duty steel cable, with a strong scissor hood (2) at one end, and an equally strong spring hook (3) at the other. Cotter pin (4) is supplied to secure the installation.

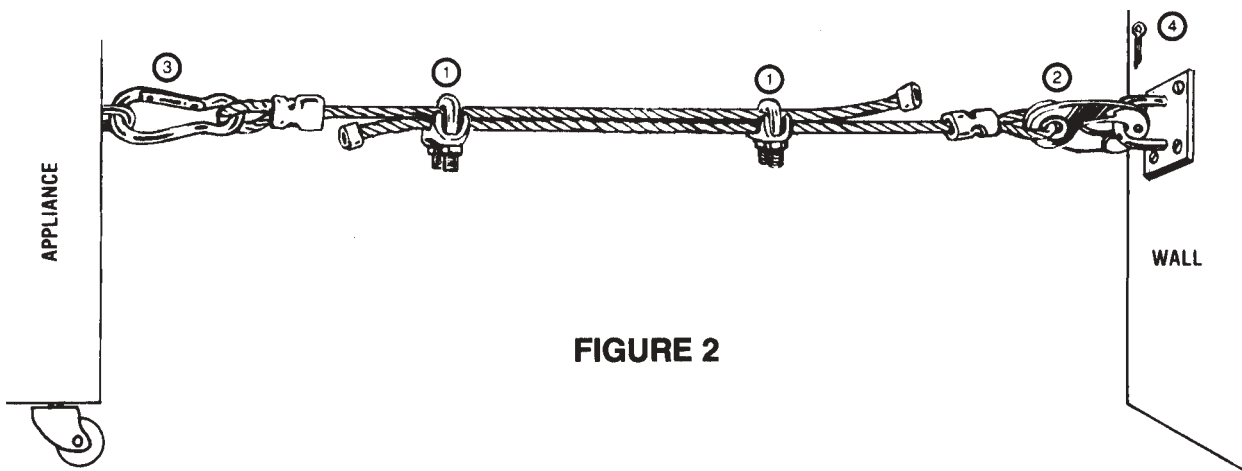
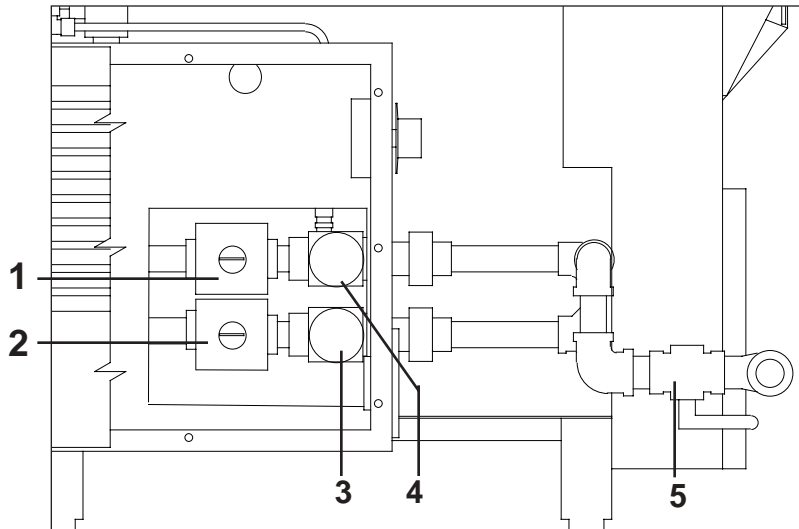
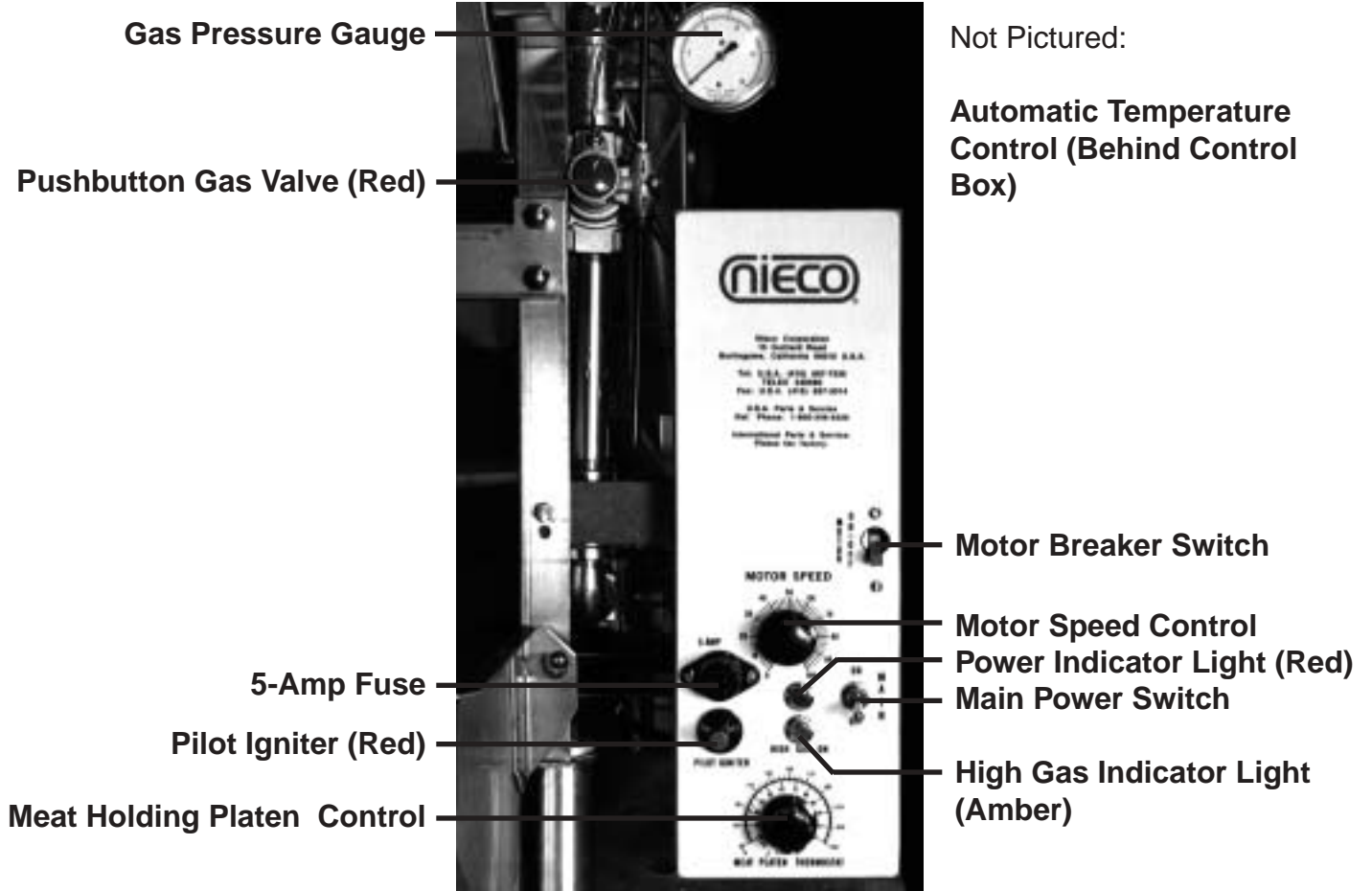

FIGURE 2

IMPORTANT: This Restraining Device should be ordered with every connector for Movable appliances.

C.OPERATION

Control and Indicators



GAS SYSTEM CONTROLS

- | | |
|--|---|
| <p>1. Main Gas Pressure Regulator.
Controls the gas pressure when the High Gas is off.</p> <p>2. High Gas Pressure Regulator.
Controls the gas pressure in High Gas mode.</p> <p>3. High Gas Solenoid.</p> | <p>4. Main Gas Solenoid.</p> <p>5. Manual Gas Valve.
Valve is open when in line with pipe</p> |
|--|---|

STEP-BY-STEP LIGHTING PROCEDURE

Before lighting, make sure that all parts are installed in the proper location, all controls are turned off, and the ventilation hood fan is turned on.

1. Turn on Main Power Switch.



2. Turn on Motor Switch.

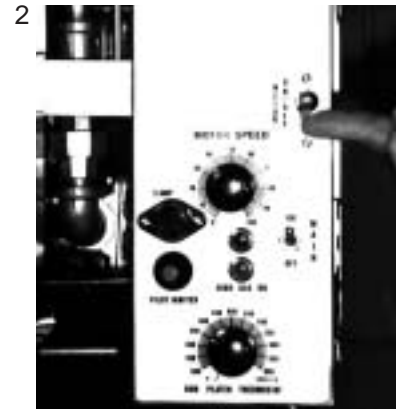

3. Set Motor Speed Control knob to desired setting. (Use "40" to start).

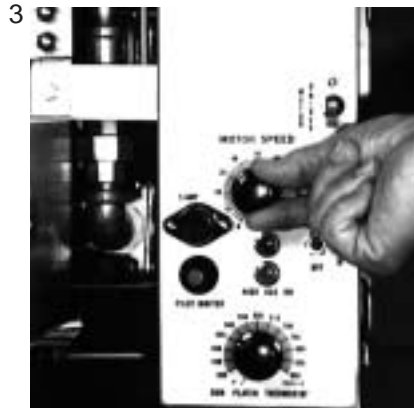

4. Set Meat Holding Temperature by adjusting the temperature controller. (Use 190° F setting to start).

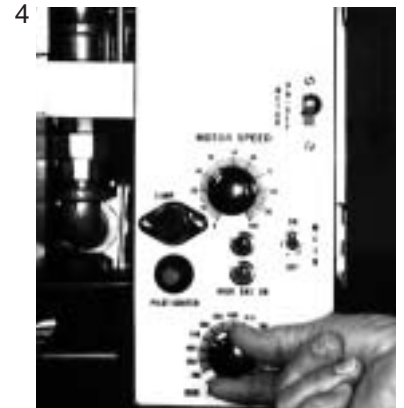

5. Open the Manual Gas Valve. The valve is open when the handle is in-line with the pipe.

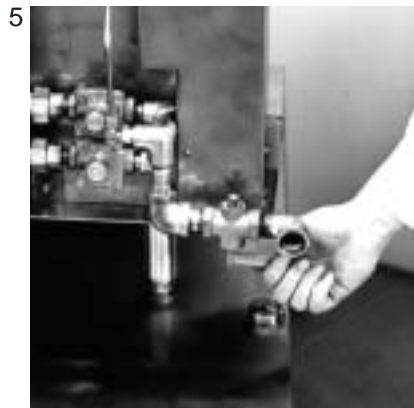

6. Push and hold the Red Push Button Valve. This will start the flow of gas to the pilot lights. While holding in the Red Button, push the Igniter button on the front of the control box. After the pilot lights, hold the Red Valve in for 30 seconds to allow the thermocouple to heat. When you release the Red Push Button, the burners should ignite. If the igniter is not working, use a long-stem lighter to manually light the pilot.



7. After lighting the broiler, check the gas pressure to be sure it is adjusted to the levels stated on the machine rating plate. Allow the broiler at least 30 minutes to warm up.

SHUTDOWN PROCEDURE

For EMERGENCY shutdown, turn off the Main Power switch and shut off the manual gas valve. For PLANNED shutdowns - clear machine of all food products, turn the motor and main switches off.

CAUTION: Turn all appliance switches off before disconnecting cord from power supply.

AUTOMATIC TEMPERATURE CONTROL (ATC)

The Nieco Automatic Temperature Control (ATC) is a system that operates the broiler at two different energy input rates; a high energy input for initial warm-up and periods of high volume, and low energy for regular operation. This dual input rate and the ATC allow the broiler to operate at a very consistent temperature throughout the day and thus provide a very consistently broiled product. Since the broiler will remain on the lower input rate (low gas) most of the day, a substantial energy savings is realized.

The ATC consists of two gas pressure regulators piped in parallel, a solenoid valve in series with the high gas pressure regulator, a probe to sense the temperature at the loading end of the broiler, and a control unit which is operated by the signals from the probe. The control unit causes the solenoid valve to open and close. When the valve is open, the machine is in high gas mode, and the gas pressure is increased to heat up the broiler.

Under heavy product loads, the temperature sensed by the ATC probe will drop low enough to cause the ATC to open the solenoid valve. When the solenoid valve opens, the amber indicator light on the control panel will light. The ATC will keep the broiler on high pressure until the temperature sensed by the probe returns to the calibrated setting.

CALIBRATING THE ATC

1. Loosen the control knob lock screw and set the ATC control knob to 600° F.
2. Turn on the Main Power Switch.
3. Turn on the Motor Power Switch.
4. Light the broiler following the procedure in this manual.
5. The broiler should be in high gas mode at this time. (Amber light on.)
6. When the broiler reaches 600°, the high gas will shut off, and the broiler will be in low gas.
7. 40 minutes after lighting the broiler, slowly turn the ATC control knob up (clockwise) until the high gas clicks on. This is the idle temperature of the broiler.
8. As soon as the high gas turns on, slowly turn the ATC down (counter clockwise) 10° to 20° below the point where the high gas turns on.
9. Tighten the control knob lock screw to prevent accidental movement.
10. The control knob setting may need a minor adjustment on the first day of use, in order to maintain 10° to 20° below the normal idle temperature. Once the adjustment is correct, it need not change from day to day unless the broiler operating conditions change.

WARNING

Never set the ATC control knob at a setting high enough to keep the broiler in high gas pressure. The machine may be damaged, energy costs will be much higher, and some broiler parts may wear out prematurely.

MEAT HOLDING SECTION

The Models 732/735, 532/535, 522 are equipped with a temperature controlled meat holding area beneath the cooking chamber. Finished product automatically slides into the holding area after cooking. Cooking guidelines call for a holding temperature of 155°, and a maximum holding time of ten minutes. The temperature of the holding area can be adjusted for proper performance. Use a setting of 200° F to start, and adjust as necessary.

D. PARTS AND LOCATION

Model 732/735 Gas - Feed End View

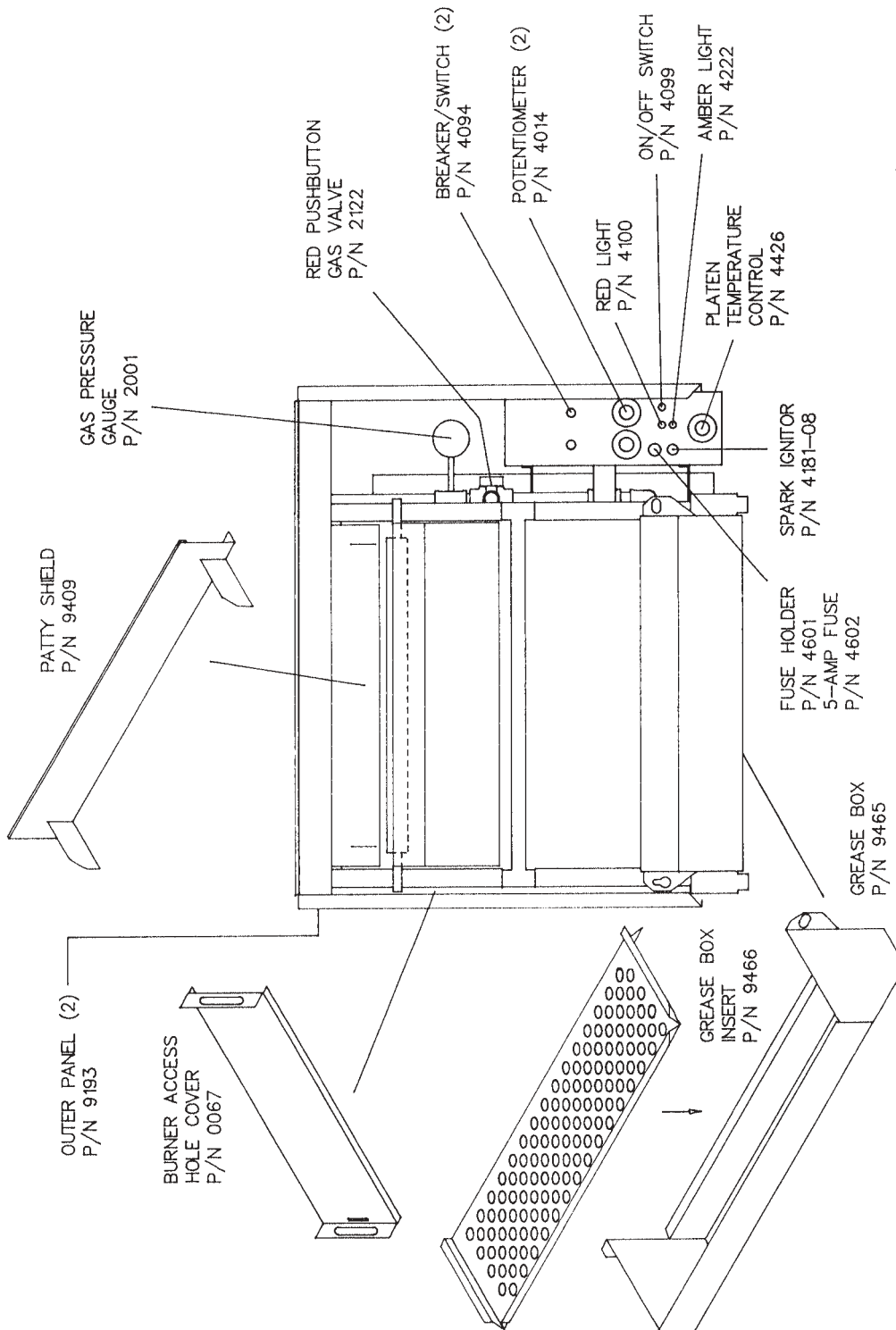

REGISTERED NESCO CORP., 1996

DWG8897 1-12-96

Model 732/735 Gas - Right Side View

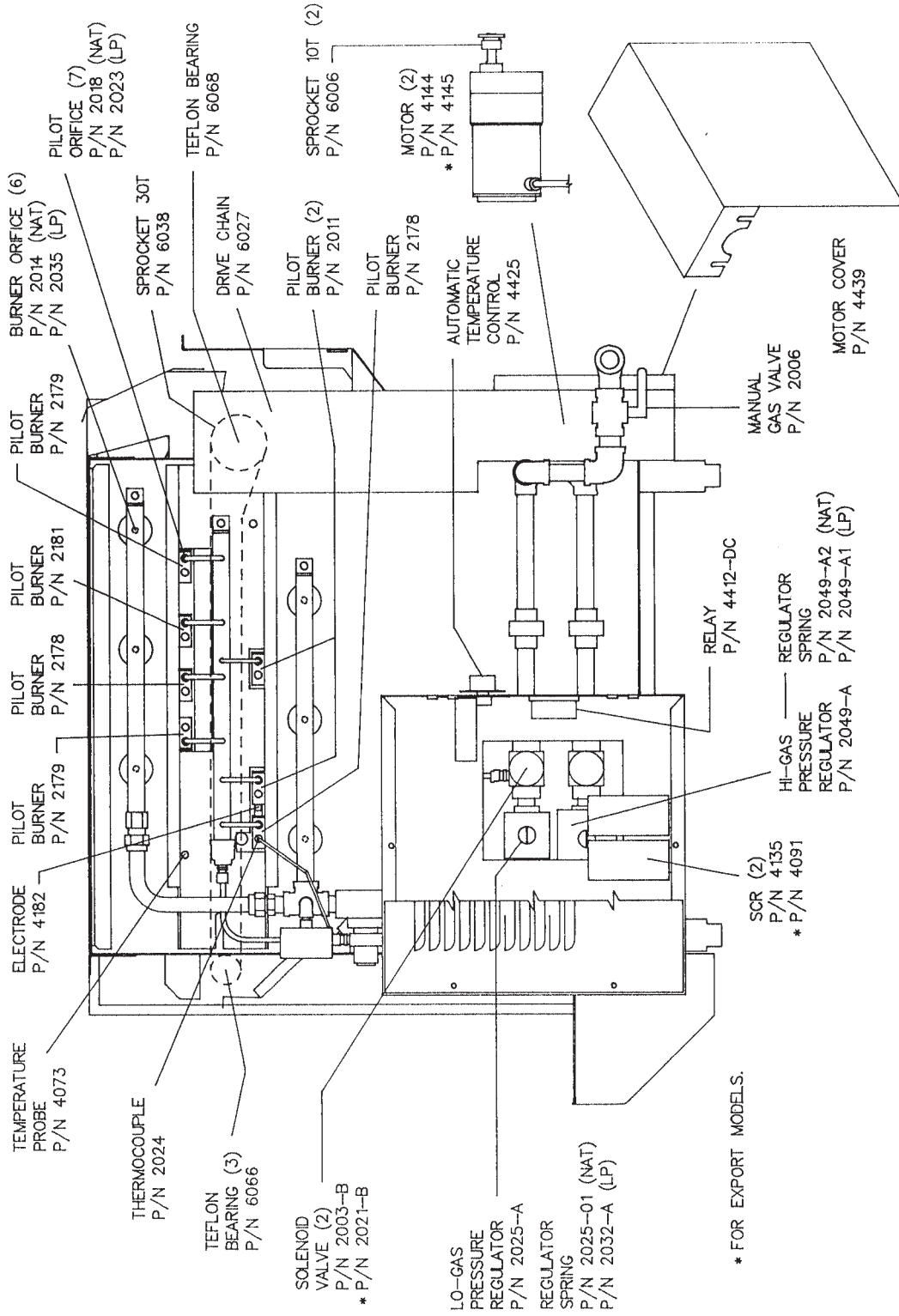

* FOR EXPORT MODELS.

REGISTERED NECO CORP., 1996 DWG8697B 4-24-96

Model 732/735 Gas - Left Side View

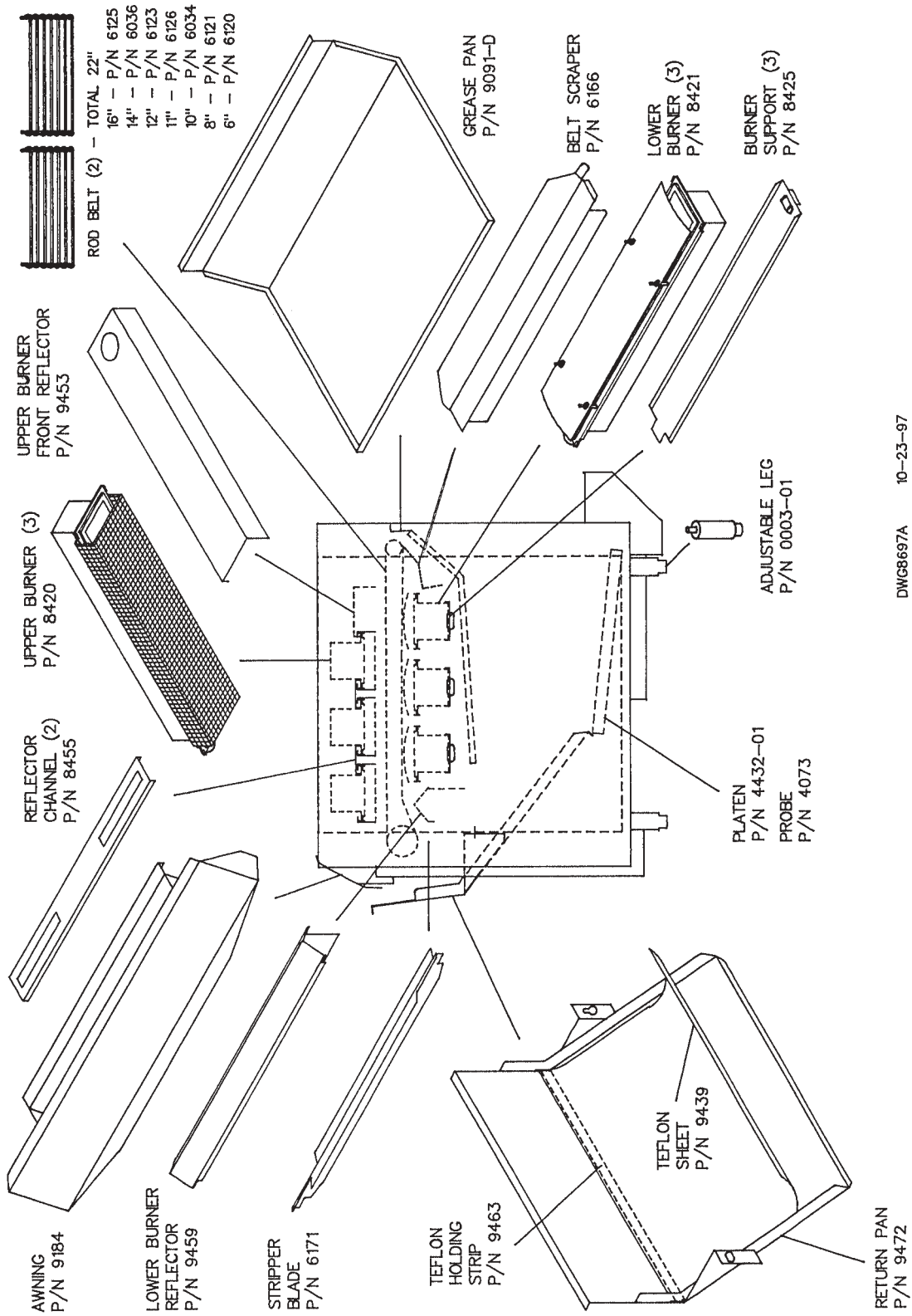

DWG8697A 10-23-97

Model 532/535 Gas - Feed End View

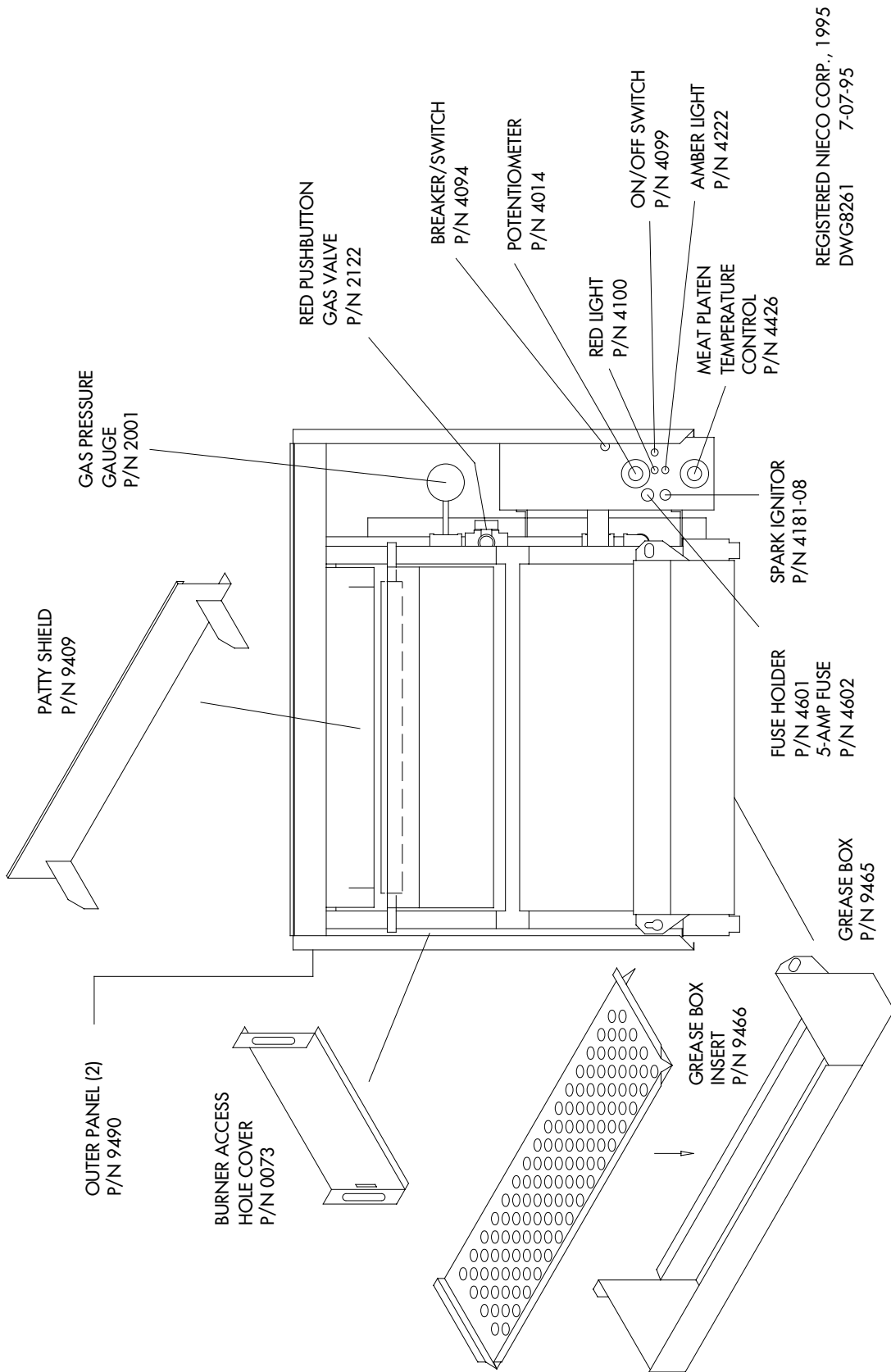

REGISTERED NIECO CORP., 1995
 DWG8261 7-07-95

Model 532/535 Gas - Right Side View

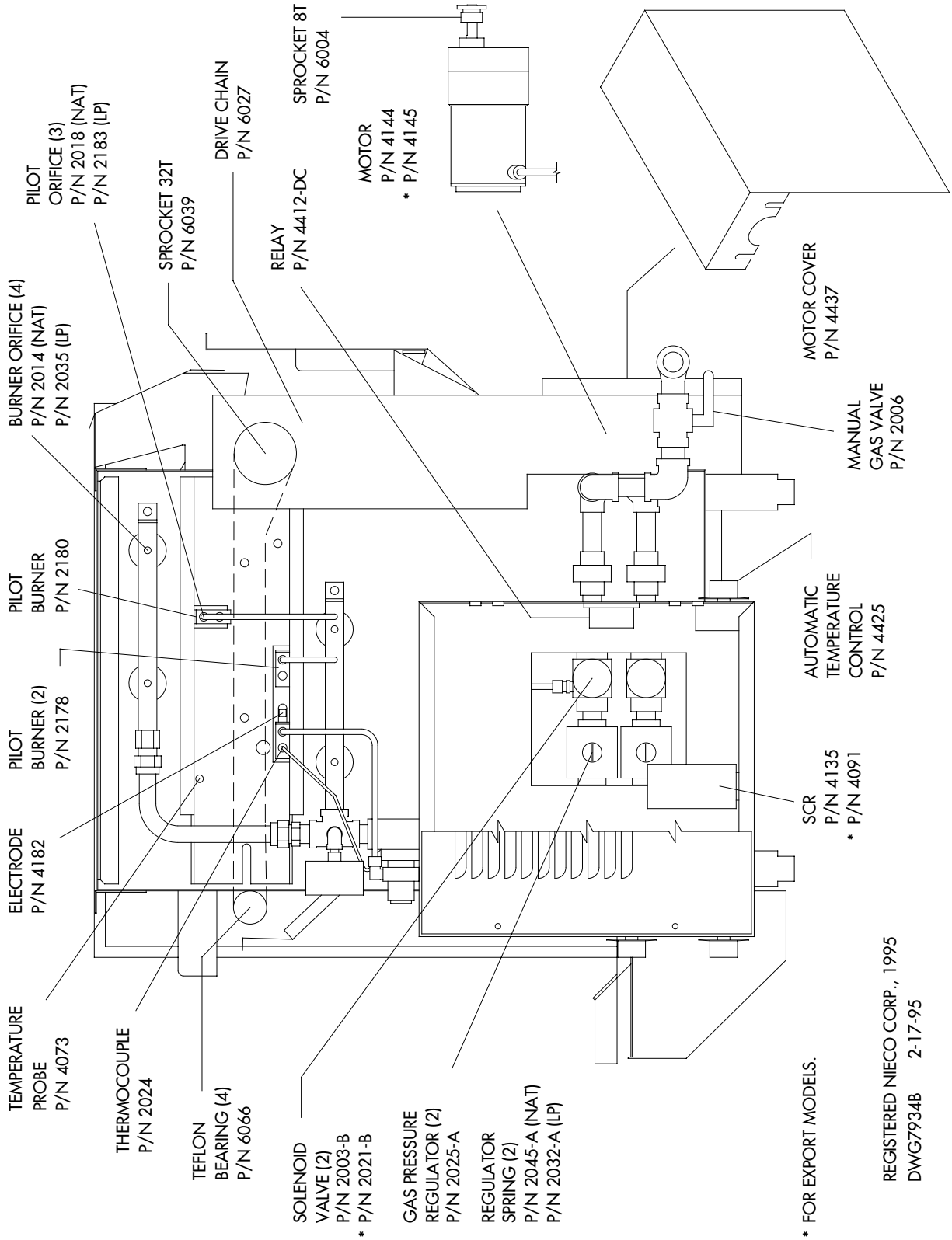

* FOR EXPORT MODELS.

REGISTERED NIECO CORP., 1995
 DWG7934B 2-17-95

Model 532/535 Gas - Left Side View

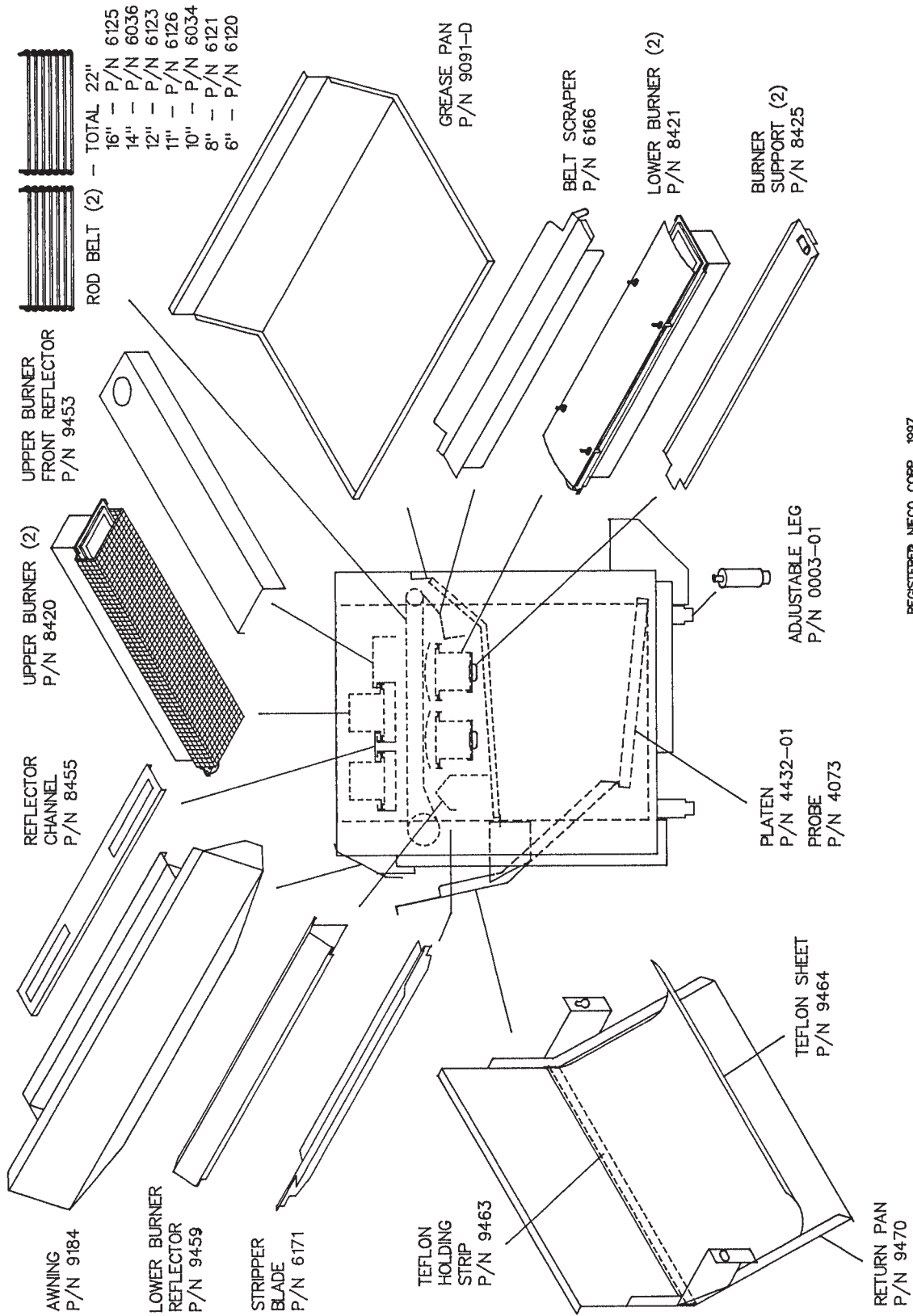

REGISTERED NIECO CORP., 1997
DWG8881A 10-27-97

Model 522 Gas - Feed End View

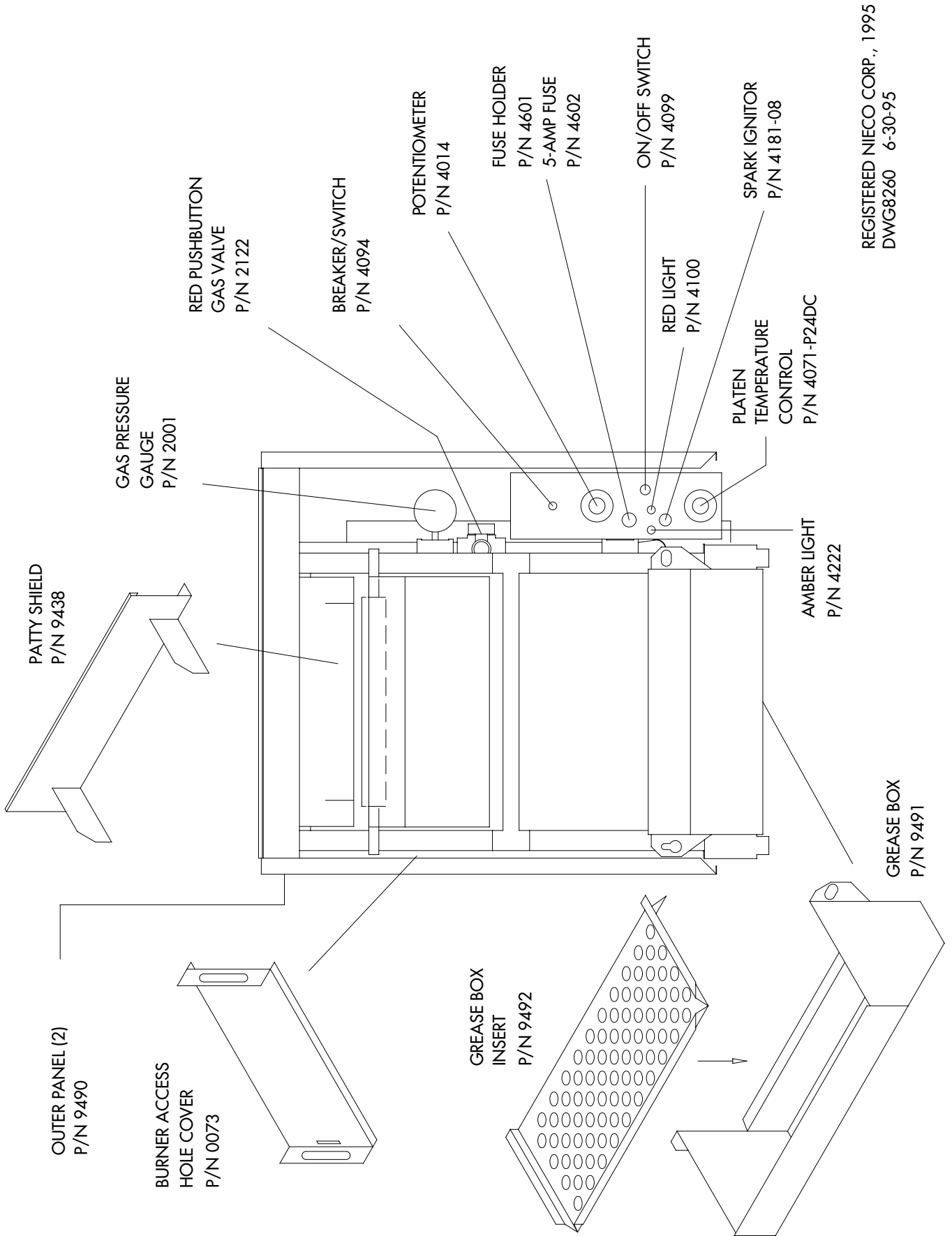

REGISTERED NIECO CORP., 1995
 DWG8260 6-30-95

Model 522 Gas - Right Side View

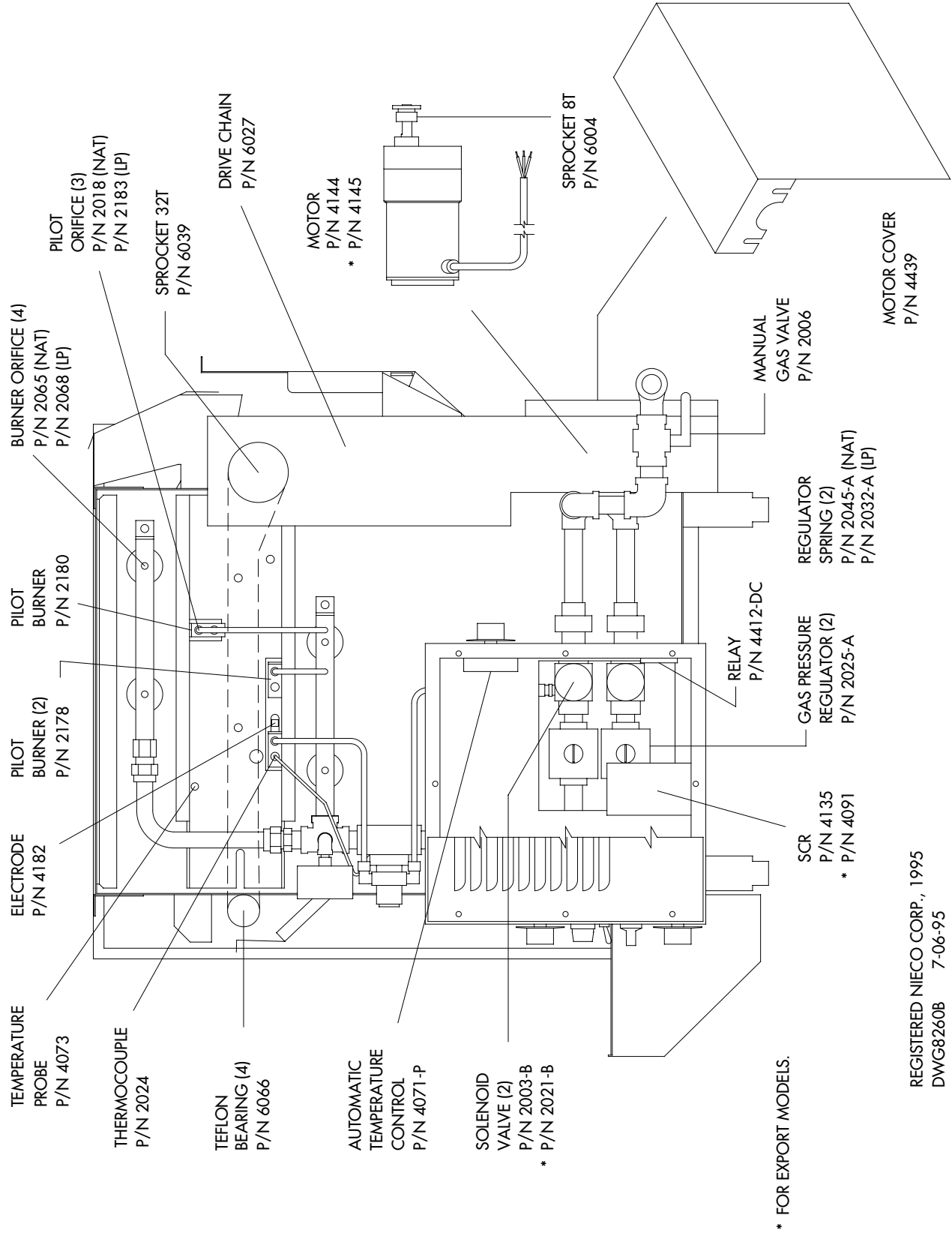

* FOR EXPORT MODELS.

REGISTERED NIECO CORP., 1995
 DWG8260B 7-06-95

Model 522 Gas - Left Side View

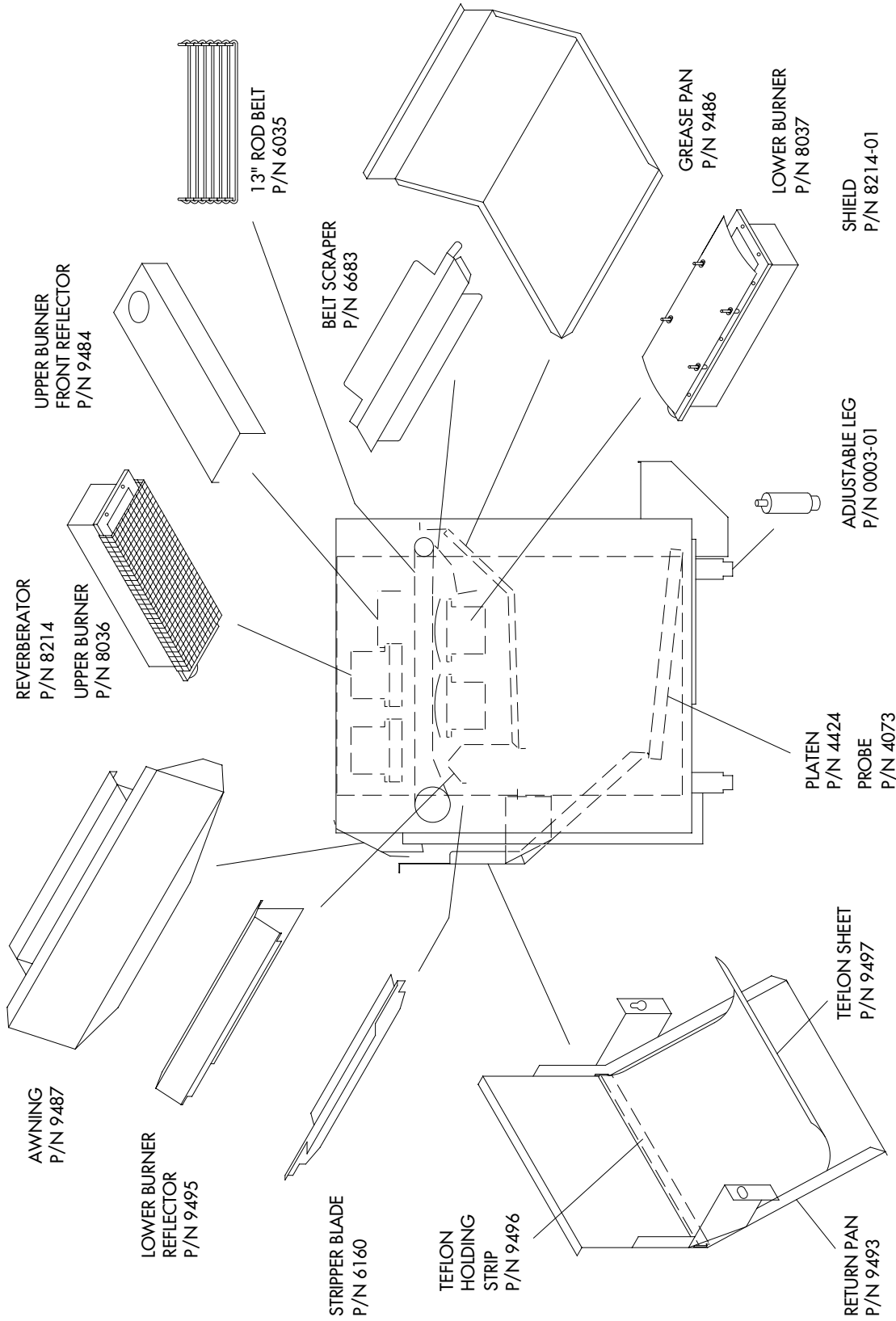

REGISTERED NIECO CORP., 1994
 DWG8260A 12-14-94

E. ASSEMBLY/DISASSEMBLY AND CLEANING

If this appliance is connected to the gas supply by a flexible gas line and quick disconnect coupling, it must also be connected to a restraining device (see installation instructions). If the appliance is moved and then returned to its original position, it must be reconnected to the restraining device and the casters locked before resuming operation.

1. Clear machine of all food products. Allow the machine to run for ten minutes empty in order to burn off the residue on the belt. Turn Main Power and Motor switches off. Allow the machine to cool before you disassemble.

2. Remove the Side Panels by lifting up and off. Wipe clean with a degreaser.



FROM THE FRONT OF THE BROILER

3. Remove the Patty Feeder by lifting up and out. Clean daily using soap and water.



4. Remove the Upper Burner Front Reflector, and clean with soap and water.

5. Remove the Grease Pan by sliding it out the front. Clean daily using soap and water.

6. Remove the Belt Scraper. Notice the position it sits in before removing, so that you can replace it properly. Clean daily using soap and water or degreaser.

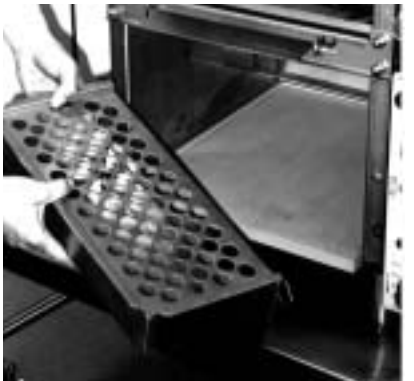

7. With a plastic spatula, scrape the excess grease and meat from the meat platen into the Grease Box, and remove the Grease Box and Insert. Dispose of the grease properly, and wash using soap and water. Sanitize the insert.



8. Wipe clean and sanitize the Meat Holding Platen.

FROM THE LEFT SIDE OF THE BROILER

9. Remove the Burner Access Cover.

9



10



10. Slide the Lower Burners out and remove the Protective Shields. Clean the shields by scraping off any built up residue, then soak in soap and water. **Clean the shields daily. This will help to prolong the life of the burner and keep the broiler cooking properly.**

FROM THE BACK OF THE BROILER

11. Remove the awning by lifting up and off. Clean using soap and water.

11



12



12. Remove the Return Pan by lifting off the pegs and sliding out. Clean and sanitize the pan and the Teflon Sheet. **The Teflon Sheet can be flipped over if one side becomes worn.**

13. Remove the Stripper Blade. Scrape any built up residue from the blade. Clean by soaking in soap and water. Sanitize.

13



14



14. Remove the Lower Burner Reflector. Notice the position of the piece before removing it, so that you can re-install it properly. Clean by soaking in soap and water.

WEEKLY CLEANING

15. Remove the Lower Burners through the access hole in the side of the broiler.

Clean the Distributor Screen and Venturi in the same fashion as the Upper Burners. Refer to instruction 16 below.

15



16. Remove the Upper Burners and clean as follows:

16



- A. Remove Reverberator and clean with a stiff bristle brush.

- B. Clean Distributor Screen with a stiff bristle brush.

- C. Clean Burner Venturi with a stiff bristle brush.

REPLACE REVERBERATOR AT THE FIRST SIGN OF BREAKAGE.

HOLD BURNER WITH THE SCREEN FACING DOWN WHILE BRUSHING.
This prevents particles from dropping down and lodging inside the burner.

HOLD BURNERS SO THAT PARTICLES WILL NOT DROP INSIDE.

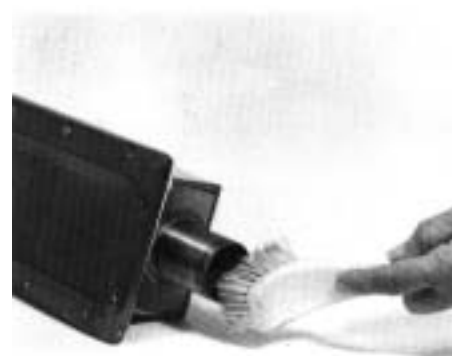

CAUTION: Do not immerse the burners in water. Water will damage the gasket, and may cause improper burner performance. The outside of the burner box can be wiped clean with a damp cloth and soap.

17. Wipe off the frame and other internal parts of the broiler. Do not spray anything (i.e. oven cleaner) inside the broiler.

F. CONVEYOR BELT REMOVAL

Before beginning, notice the way the belt runs through the broiler. Also notice the direction the knuckles face. Be sure to re-assemble in the same way.

1. Run belt until the Master Link is near the front idler shaft. 1

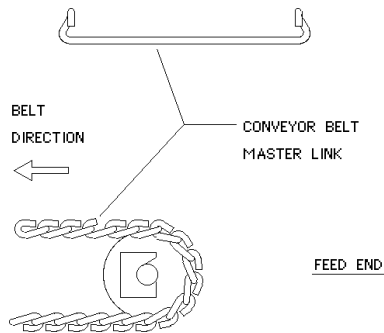

2. Lift shaft and Teflon Blocks up, 2
3 and slide the blocks out.



3. Unhook the Master Link.

To reassemble, reverse the procedure. Be sure to reassemble the belt with the knuckle opening facing away from the direction of travel.

G. CONVEYOR BELT TENSION

Maintain proper tension on the conveyor belts to prevent jamming. Bearing spacers (pictured below) are supplied with the broiler to make minor tension adjustments. Major tension adjustments are made by removing a link or links from the belt.

The diagram on the left shows the spacer in the stored position. The diagram on the right shows the spacer behind the teflon bearing tightening the belts.

Belt tension should be checked monthly. To do this, allow the machine to cool, then grip the idler shaft at each end and pull on it. If the shaft and bearings move $\frac{3}{16}$ " or more, the spacers should be placed behind the bearings to tighten the belts. If the spacers are already behind the bearings, return them to the stored position and remove a link from the conveyor belt.

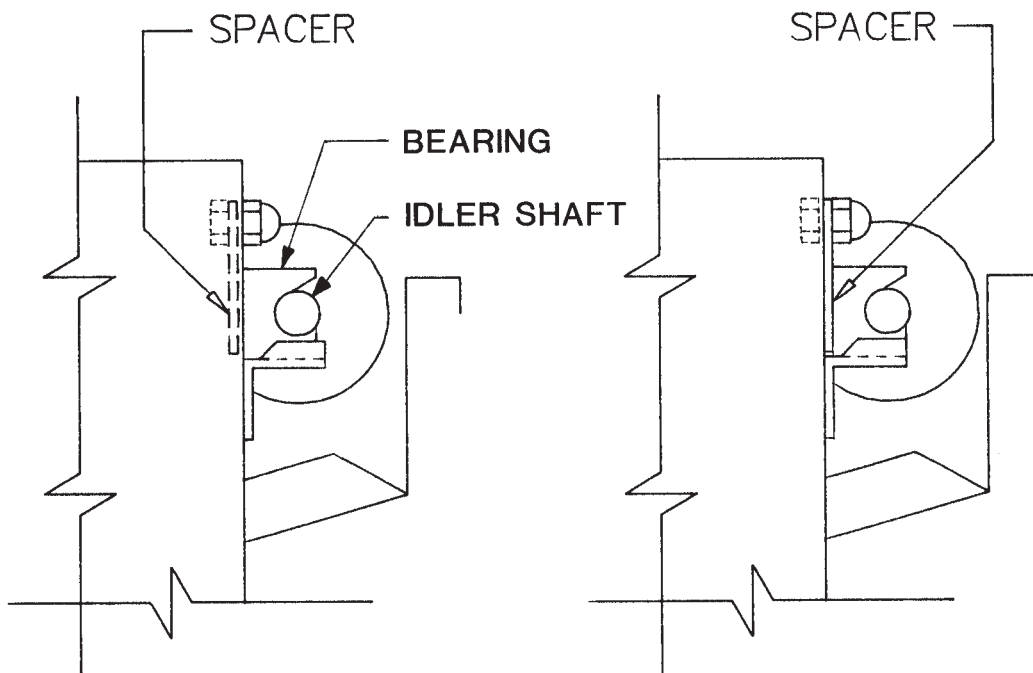

BROIL BELT PROBLEMS

Interference with stripper blade:

The most common belt problem to be expected is the physical interference of the belt with the stripper blade. This is caused by bent or warped rods on the meat belt, and can be fixed by replacing the rods that are causing the problem. Other causes are bent stripper blades, or utensils jammed in the belt.

Blocked belts:

When trouble shooting drive problems, it is important to ensure that the belt is not being blocked. To do this, detach the drive chain and turn the meat belt by hand. The belt, with the motor detached, should turn freely and easily. If the blockage has occurred which is preventing the belt from turning, the blockage should be removed before the drive chain is re-attached. The drive chain can be easily removed from the drive sprocket (on the motor shaft) by loosening the mounting bolts and raising the motor.

H. TROUBLESHOOTING GUIDE

Identify the problem in the left column, then look for probable causes and solutions in the center and right hand columns. Probable causes are listed in the order of “most likely to happen”. This sequence should be used to isolate the problem.

Once the cause is found, refer to OPERATION or PARTS AND LOCATION section for further explanation of function or repair part needed.

1. Pilot burners won't light.	<ol style="list-style-type: none"> 1. Pilot burner dirty or orifice plugged. 2. Pushbutton valve not fully depressed. 3. Main gas supply not on or not connected properly. 4. Air in pilot line. 5. Electric spark dislocated. 6. Electrical power not on or plugged in. 	<ol style="list-style-type: none"> 1. Clean pilot burner, replace orifice. 2. Repeat starting procedure. 3. Check gas supply. 4. Purge line. 5. Realign spark head with burner housing. 6. Plug in/Turn on.
2. Pilots won't stay lit when the pushbutton valve is released.	<ol style="list-style-type: none"> 1. Thermocouple not hot yet. 2. Weak pilot flame. 3. Thermocouple dirty or defective. 4. Red Push Button Unit defective. 	<ol style="list-style-type: none"> 1. Repeat starting procedure. 2. See #3 and 4 below. 3. Clean or replace. 4. Replace.
3. Pilot flame weak or yellow.	<ol style="list-style-type: none"> 1. Dirty pilot or venturi. 2. Dirty pilot orifice. 3. Pilot line plugged or pinched off. 4. Incoming gas pressure too low. 	<ol style="list-style-type: none"> 1 Clean. 2. Clean with a needle or replace. 3. Check line. 4. Increase gas pressure.
4. Main burners won't light, or they go out during operation.	<ol style="list-style-type: none"> 1. Pilot flame too small. 2. Air draft blowing pilot flame out. 3. Electrical supply interruption. 4. See #2 and 3 above. 	<ol style="list-style-type: none"> 1. Clean or replace pilot orifice. 2. Check for drafts coming through the broiler. 3. Secure power supply.
5. Burner(s) appear dim.	<ol style="list-style-type: none"> 1. Orifices dirty. 2. Gas pressure too low. 3. Main gas valve partially closed. 4. Gas line partially blocked. 5. Pressure regulator defective. 6. Burners not installed properly. 7. Burner venturi dirty. 8. Burner mesh dirty. 	<ol style="list-style-type: none"> 1. Clean. 2. Adjust gas pressure. 3. Open fully. 4. Clear gas lines. 5. Replace. 6. Install in the proper location. 7. Clean - see CLEANING section. 8. Clean - see CLEANING section.
6. Burner(s) make popping or fluttering noise and may go out.	<ol style="list-style-type: none"> 1. Gas pressure too high. 2. Burner mesh dirty. 3. Orifice or venturi dirty. 4. Defective gasket. 	<ol style="list-style-type: none"> 1. Adjust gas pressure. 2. Replace. 3. Clean. 4. Replace.
7. Conveyor belts won't advance.	<ol style="list-style-type: none"> 1. Machine not plugged in. 2. Wall circuit breaker off. 3. Motor control set to "0". 4. Motor switch off. 5. SCR unplugged or defective. 6. Drive chain broken. 7. Drive sprocket loose. 8. Gear motor defective. 9. Loose or broken wire. 10. Motor unplugged. 11. Speed pot defective. 	<ol style="list-style-type: none"> 1. Plug in. 2. Reset. 3. Increase setting. 4. Turn on. 5. Plug in or replace. 6. Repair. 7. Tighten set screws. 8. Replace. 9. Tighten and repair. 10. Plug in. 11. Replace.

8. Motor control switch trips.	<ol style="list-style-type: none"> 1. Conveyor chains jammed. 2. Switch defective. 3. Drive chain binding. 4. Shorted wire to motor. 5. Gear motor defective. 6. SCR unplugged or defective. 7. Potentiometer defective. 8. Motor plug or receptacle defective. 	<ol style="list-style-type: none"> 1. Remove jam. 2. Replace. 3. Adjust tension, lubricate. 4. Repair. 5. Repair or replace. 6. Plug in, or replace. 7. Replace. 8. Replace.
9. Conveyor speeds are erratic.	<ol style="list-style-type: none"> 1. SCR loose or defective. 2. Drive chain binding. 3. Loose drive sprocket. 4. Potentiometer defective. 	<ol style="list-style-type: none"> 1. Plug in or replace. 2. Adjust tension, lubricate. 3. Tighten set screws. 4. replace.
10. Meat holding platen won't heat.	<ol style="list-style-type: none"> 1. Wall circuit breaker off. 2. Platen heat control set at "0". 3. Loose or broken wire. 4. Defective heat control. 5. Machine not plugged in properly. 6. Defective plug or receptacle. 7. Platen elements failed. 	<ol style="list-style-type: none"> 1. Reset. 2. Increase to proper setting. 3. Tighten or repair. 4. Replace. 5. Plug in, twist plug. 6. Replace or repair. 7. Replace.
11. Meat holding platen gets warm but not hot.	<ol style="list-style-type: none"> 1. Inadequate voltage. 2. Broiler not plugged in completely. 3. Loose or broken wire. 4. Heat control set too low. 5. Defective plug or receptacle. 	<ol style="list-style-type: none"> 1. Check supply voltage. 2. Plug in and twist plug. 3. Repair or replace. 4. Increase setting. 5. Repair or replace.
12. Meat holding platen gets too hot.	<ol style="list-style-type: none"> 1. Heat control set too high. 2. Heat control defective. 3. Probe defective. 4. Improper voltage supply. 	<ol style="list-style-type: none"> 1. Decrease setting. 2. Replace. 3. Replace. 4. Check and correct supply.
13. Broiled product over or under cooked.	<ol style="list-style-type: none"> 1. Wrong conveyor belt speed. 2. Internal heat reflectors missing or improperly installed. 3. Burners have holes or are dirty. 	<ol style="list-style-type: none"> 1. Adjust belt speed. 2. Refer to Parts and Location Section. 3. Clean or replace burner screens.
14. Required broil time too long.	<ol style="list-style-type: none"> 1. Product too thick. 2. Product temperature too low. 3. Product too lean. 4. Exhaust fan pulling too much air. 5. Exhaust hood too low. 6. Air vent blowing on broiler. 7. Heat reflectors inside broiler not installed, or installed improperly. 	<ol style="list-style-type: none"> 1. See MEAT GUIDE. 2. See MEAT GUIDE. 3. See MEAT GUIDE. 4. Adjust to proper CFM. 5. Should be at least 12" above broiler. 6. Redirect air vents. 7. Install in the proper location. Refer to parts and Location Section.
15. Outside of product overdone, inside underdone.	<ol style="list-style-type: none"> 1. Product too thick or not scored. 2. Product too cold. 3. Improper gas pressure. 4. ATC not functioning properly. 	<ol style="list-style-type: none"> 1. See MEAT GUIDE. 2. See MEAT GUIDE. 3. Increase or decrease - refer to machine rating plate on control box. 4. Check calibration.
16. None, or light sear marks.	<ol style="list-style-type: none"> 1. Conveyor too fast or slow. 2. Product too cold. 3. Lower burners or shields dirty. 4. Lower reflector missing or dirty. 	<ol style="list-style-type: none"> 1. Adjust speed. 2. See MEAT GUIDE. 3. Check condition/clean. 4. Install or clean.

<p>17. Broiled product sticks to conveyor belt.</p>	<ol style="list-style-type: none"> 1. Stripper blades not adjusted properly. 2. Product under broiled. 3. Product too lean. 4. Product too thin. 5. Burners not hot enough. 6. Heat reflectors not installed, or installed improperly. 7. Conveyor belt has warped or bent links. 8. Conveyor belt tension too tight. 	<ol style="list-style-type: none"> 1. Adjust by raising or lowering mounting bolts. 2. Slow belt speed. 3. See MEAT GUIDE. 4. See MEAT GUIDE. 5. See #5. 6. Install properly, refer to Parts and Location. 7. Replace or straighten links. 8. Adjust- see Conveyor Belt Tension section.
<p>18. Inconsistent broil.</p>	<ol style="list-style-type: none"> 1. Conveyor speed erratic. 2. Inconsistent product temperature. 3. Air conditioning blowing on broiler. 4. Erratic gas supply. 	<ol style="list-style-type: none"> 1. See problem #9. 2. See MEAT GUIDE. 3. Redirect vents away from broiler. 4. Check supply/call Gas Co.
<p>19. Excessive flaming in broiler.</p>	<ol style="list-style-type: none"> 1. Over cooking product. 2. Product fat content too high. 3. Gas pressure too high. 	<ol style="list-style-type: none"> 1. Speed up belt. 2. See MEAT GUIDE. 3. Reduce pressure.
<p>20. Product tears and gets holes.</p>	<ol style="list-style-type: none"> 1. Product fat content too high. 2. Product grind too coarse. 3. Product too lean, sticking to belt. 4. Product too thin. 5. Stripper blade not properly installed. 6. See #17. 	<ol style="list-style-type: none"> 1. See MEAT GUIDE. 2. See MEAT GUIDE. 3. See MEAT GUIDE. 4. See MEAT GUIDE. 5. Install correctly, adjust to proper height.

I. SPECIFICATIONS

Model 732/735 Gas

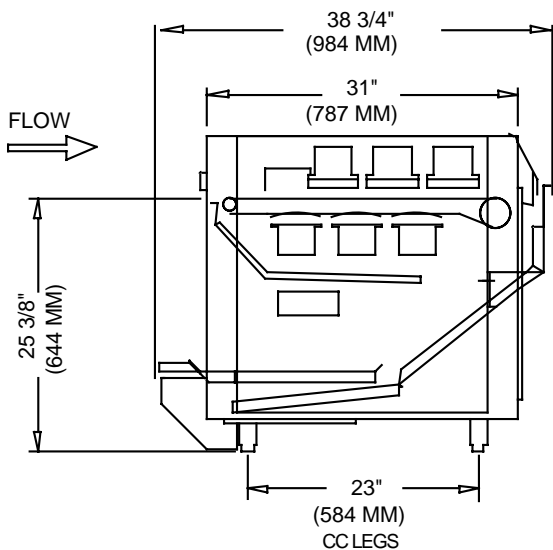
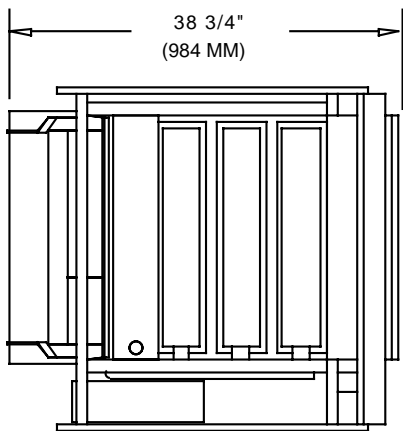
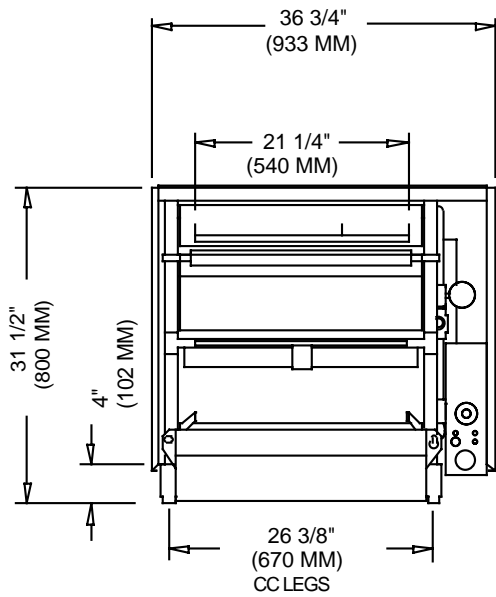

REQUIREMENTS

Energy -Gas Model

Gas Connection 3/4" N.P.T.

Electrical Connection

208/120V	1Ø	50/60Hz	10.5A
240/120V	1Ø	50/60Hz	12A

Avg. KW/Hr Consumption 2.2

Gas Consumption 75,000-96,000 BTU/Hr

@ 3" W.C. (Nat.) or 8" W.C. (L.P.) Low Gas
5" W.C. (Nat.) or 11" W.C. (L.P.) High Gas

Weight	LBS.	KG
Approximate	475	215

Exhaust	CFM	CMH
	800	1360

Dimensions	Inches	MM
Height	31 1/2	800
Width	36 3/4	933
Length	38 3/4	984

Model 532/535 Gas

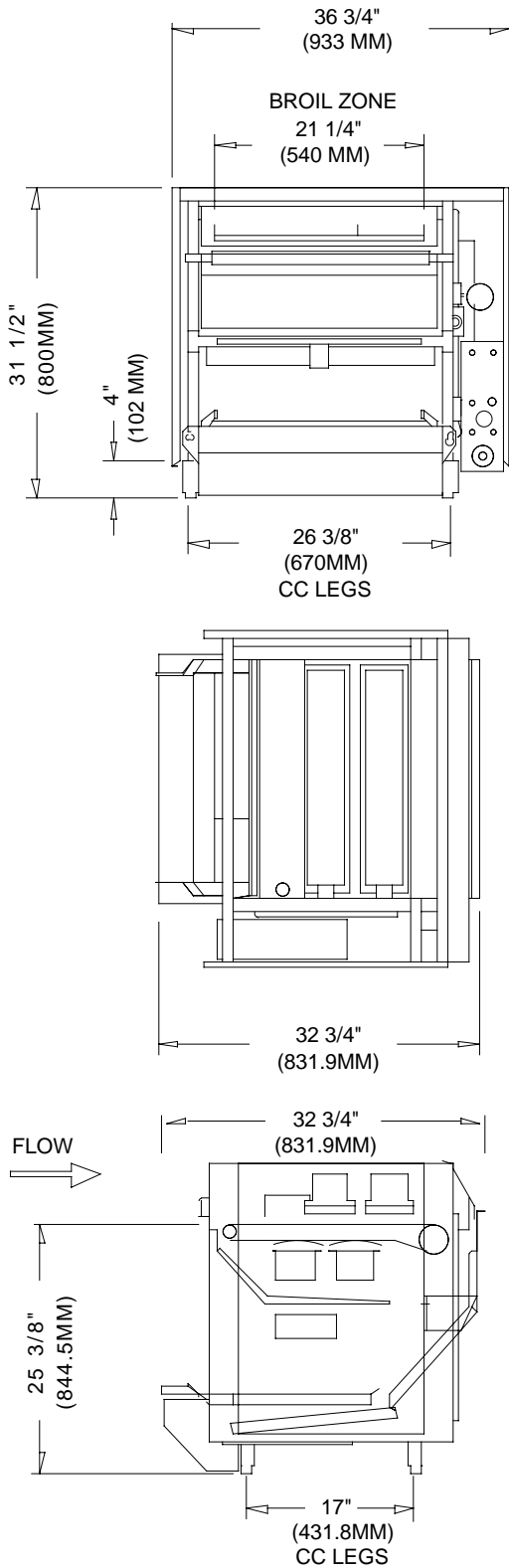

REQUIREMENTS

Energy -Gas Model

Gas Connection 1/2" N.P.T.

Electrical Connection

208Y120V	1Ø	50/60Hz	9.8A
240Y120V	1Ø	50/60Hz	10.4A

Avg. KW/Hr Consumption 1.4

Gas Consumption 49,000-63,000 BTU/Hr

@ 3" W.C. (Nat.) or 8" W.C. (L.P.) Low Gas

5" W.C. (Nat.) or 11" W.C. (L.P.) High Gas

Weight	LBS.	KG
Approximate	375	170

Exhaust	CFM	CMH
	600	1020

Dimensions	Inches	MM
Height	31 1/2	800
Width	36 3/4	933
Length	32 3/4	832

Model 522 Gas

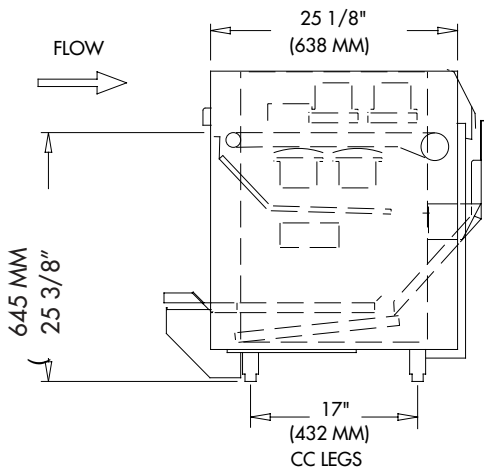
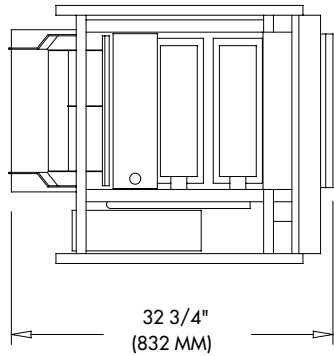
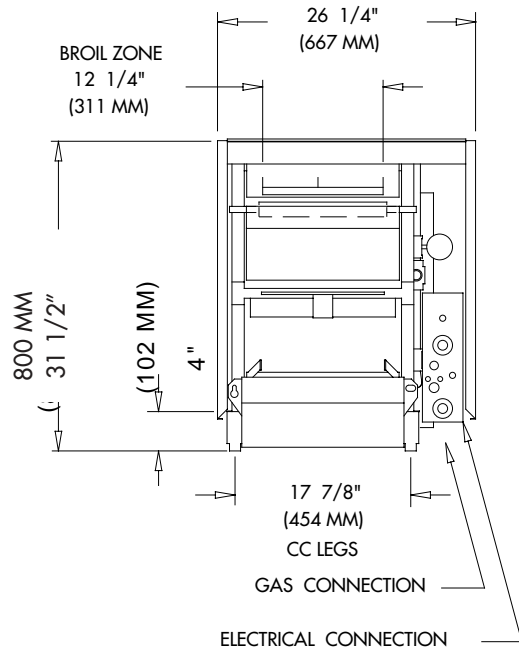

REQUIREMENTS

Energy -Gas Model

Gas Connection $\frac{1}{2}$ " N.P.T.

Electrical Connection

208Y120V	1Ø	50/60Hz	6.5A
240Y120V	1Ø	50/60Hz	7.5A

Avg. KW/Hr Consumption .9

Gas Consumption 33,000-44,000 BTU/Hr
 @ 3" W.C. (Nat.) or 8" W.C. (L.P.) Low Gas
 5" W.C. (Nat.) or 11" W.C. (L.P.) High Gas

Weight	LBS.	KG
Approximate	250	173

Exhaust	CFM	CMH
	400	680

Dimensions	Inches	MM
Height	31 1/2	800
Width	25 3/4	645
Length	32 3/4	832

J. WIRING DIAGRAM

Models 732/735/532/535G - Domestic (U.S.A.)

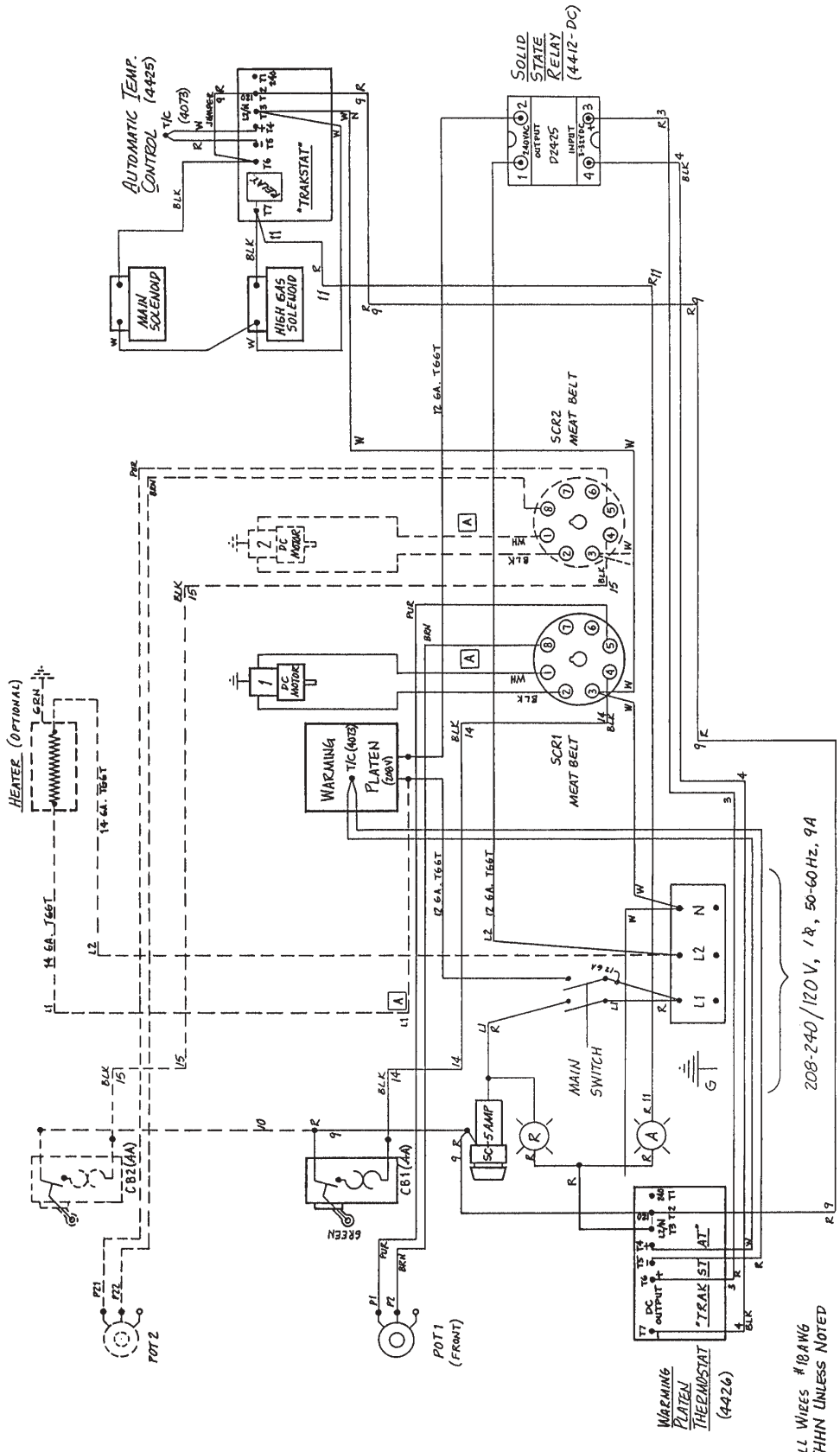

208-240/120V, 1ϕ, 50-60 Hz, 9A

ALL WIRES #18 AWG THIN UNLESS NOTED

Models 732/735/532/535G - International (Export) Models

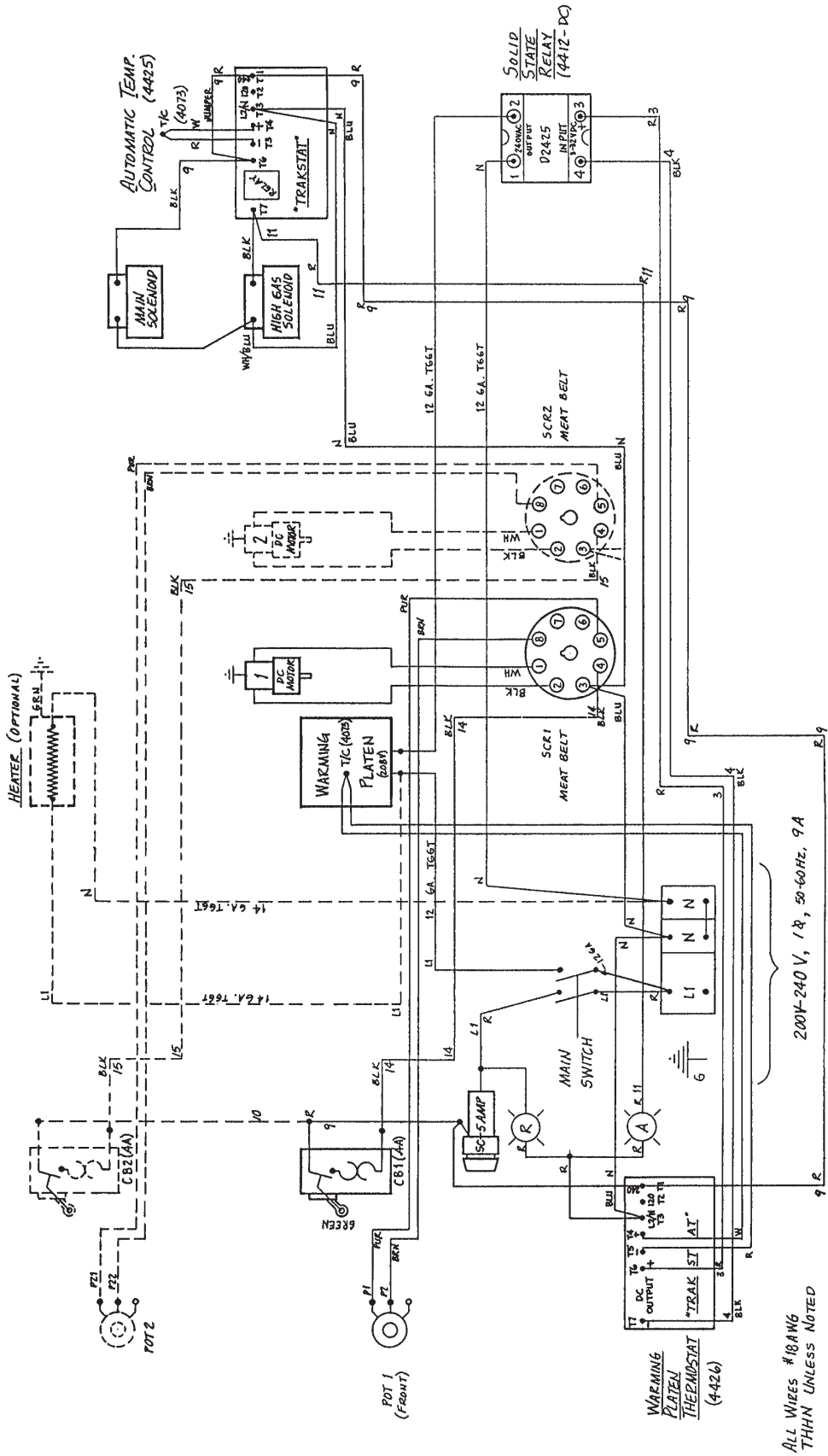

Model 522G - Domestic U.S.A.

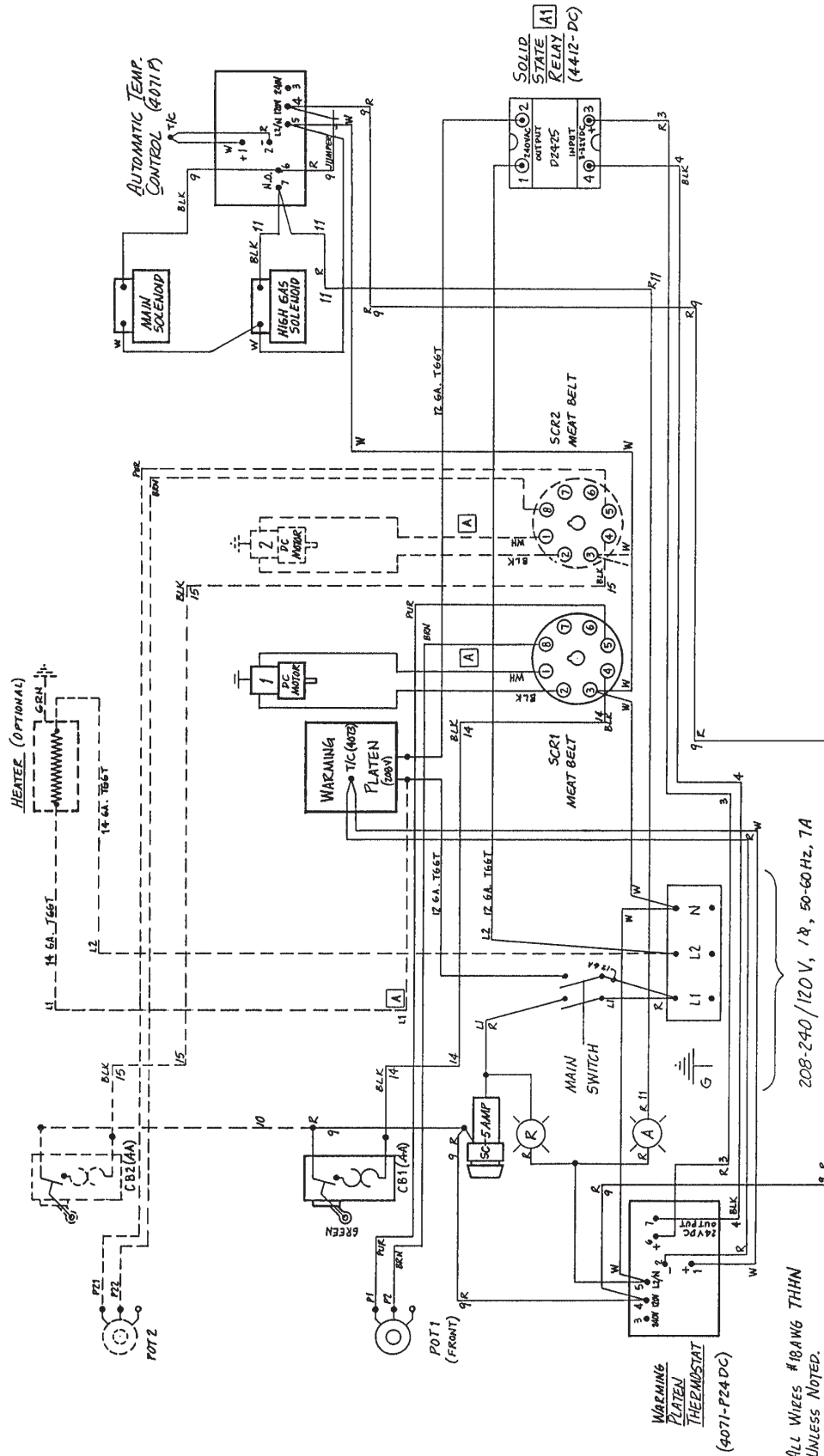

ALL WIRES #18 AWG THHN UNLESS NOTED.

Model 522G - International (Export) Models

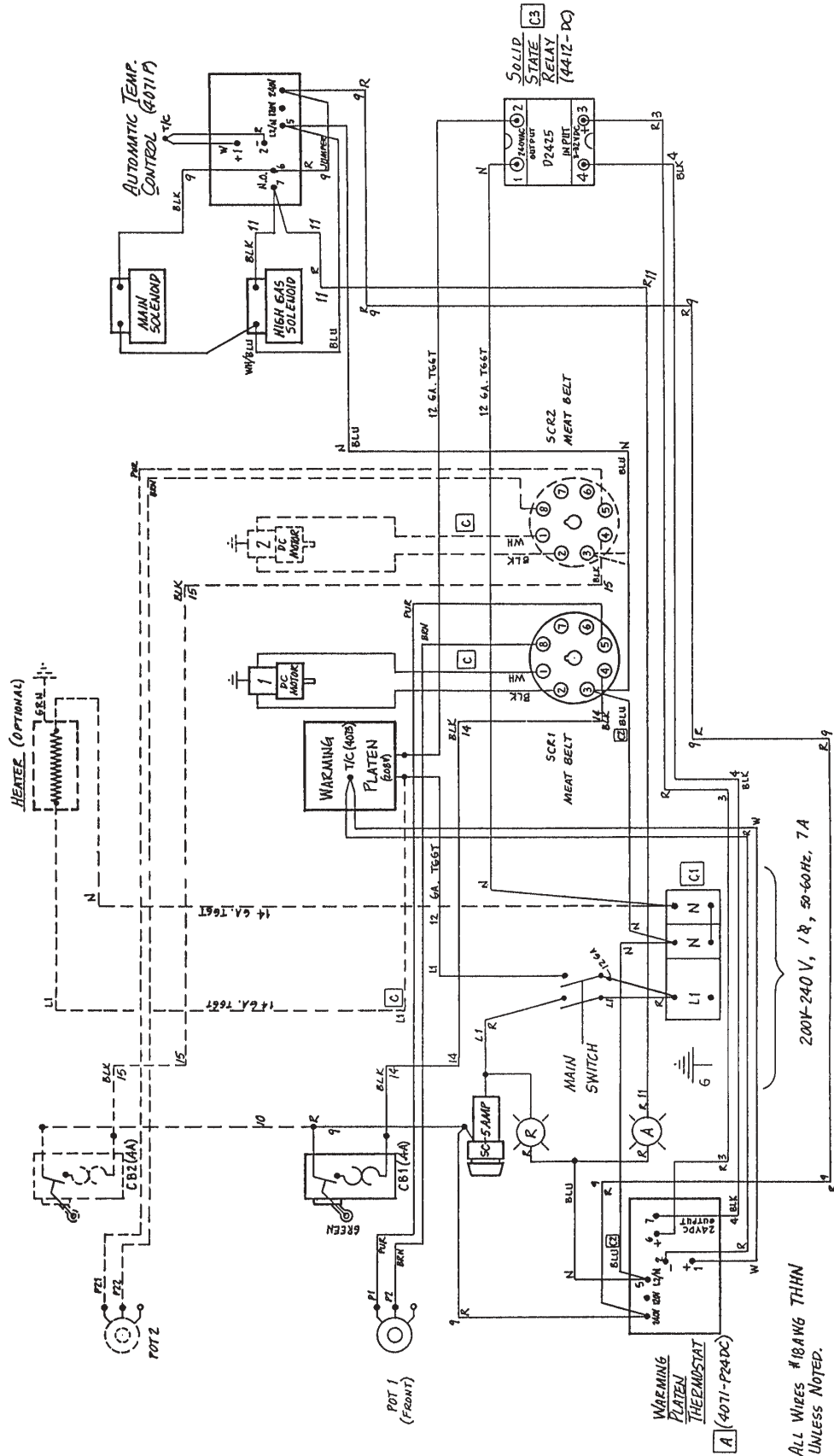



Nieco Corporation • 15 Guittard Rd. • Burlingame, CA • 94010 • (650) 697-7335 • Fax (650) 697-3014
Reorder # 9999-99102 12/99 e-mail: nieco@nieco.com Printed in the USA