



AUTOMATIC
FOODSERVICE
EQUIPMENT

AUTOMATIC GAS BROILER
MODELS 980 GAS, 950 GAS AND 930 GAS

OWNER'S MANUAL

IMPORTANT: RETAIN THIS MANUAL IN A SAFE PLACE
FOR FUTURE REFERENCE.



FOR YOUR SAFETY:

Do not store or use gasoline or other flammable vapors or liquids in the vicinity of this or any other appliance.

WARNING: Improper installation, adjustment, alteration, maintenance can cause property damage, injury, or death. Read the installation, operating and maintenance instructions thoroughly before installing or servicing this equipment.

Broiler area must be kept free of combustible materials, and the flow of combustion and ventilation air must not be obstructed. Operating personnel must not perform any maintenance or repair functions. Contact your Nieco Authorized Dealer.

In a prominent location, post instructions to be followed in the event the user smells gas. This information shall be obtained by consulting your local gas supplier.

TABLE OF CONTENTS

A. General Information	4
Description	
B. Machine Installation	5
Pre-Installation	
Mounting	
Hood Requirements	
Clearance	
Gas Connection	
Electrical Connection	
Pre-Operation Check	
Gas Connectors and Restraining Device	
C. Operation	8
Controls and Indicators	
Gas System Controls	
Step-by-Step Lighting Procedure	
Shutdown Procedure	
Automatic Temperature Control	
Bun Platen Adjustment	
D. Assembly/Disassembly and Cleaning	11
E. Conveyor Belt Removal	14
F. Conveyor Belt Tension	15
Broil Belt Problems	
G. Parts and Location	16
Model 980	
Model 950	
Model 930	
H. Trouble Shooting Guide	25
I. Specifications	27
J. Wiring Diagrams	30

A. GENERAL INFORMATION

Model 980 Gas

Model 950 Gas

Model 930 Gas



DESCRIPTION

The Nieco Automatic Gas Broiler is a compact self-contained unit designed to broil hamburgers or other food products by use of a conveyORIZED cooking section. In addition, these broilers are equipped with a bun grilling section which caramelizes the buns to a golden brown.

The hamburgers and buns are loaded on the feed end of the broiler, pass between radiant gas burners or an electrically heated bun platen, and come out the discharge end of the broiler. Flame broiling makes the food taste great, and the unique Nieco system offers un-matchable product quality and consistency.

The Model 980 uses a total of 8 gas burners - 4 on top and 4 on the bottom. The Model 950 uses a total of 6 gas burners - 3 on top and 3 on the bottom. The Model 930 uses 4 burners - 2 top and 2 bottom. All three models utilize Nieco's Automatic Temperature Control system, to assure proper cooking in periods of high volume usage.

B. INSTALLATION

PRE-INSTALLATION

Uncrate the broiler, and inspect for shipping damage. Contact the factory if there is obvious damage. Remove the tape securing the machine parts, and install the parts in their proper location. Refer to the Parts and Location section of this manual. If you find concealed damage to any part of this unit, contact your freight carrier immediately. The factory warranty does not cover freight damage.

MOUNTING

If the broiler was shipped with a tubular stand, refer to separate tubular stand assembly instructions.

Note: The four legs of the broiler stand are equipped with casters. Always set the brakes on the casters to prevent the broiler from shifting during operation or cleaning.

LEVELING

Make sure that the broiler is level. Factory stands are equipped with adjustable casters.

HOOD REQUIREMENTS

This appliance must be installed under a ventilation hood of adequate size and capacity:

Model	CFM	CMH
980	1100	1869
950	800	1360
930	600	1020

The hood should be at least 6" (152MM) larger in all dimensions than the appliance top, and be 12" to 18" (305MM - 457MM) above the top. Do not obstruct the flow of combustion and ventilation air. An adequate air supply must be available for safe and proper operation.

Note: See the National Fire Prevention Association booklet on ventilation of cooking equipment. Write to: NFPA, 470 Atlantic Ave., Boston, MA 02210. Local codes on venting must also be complied with.

CLEARANCE

For proper installation, the minimum clearance from combustible and non-combustible construction is 6" (152MM) from the back and 6" (152MM) from the front of the machine. Keep appliance area free from combustibles.

To facilitate disassembly and service of the unit a minimum of 24" (610MM) should be allowed on the control panel (right) side of the broiler, as well as in front of the broiler.

GAS CONNECTION

At rated BTU capacity, the gas supply should deliver a pressure of at least 6" water column at the broiler connection for natural gas, and 11" water column for propane gas. Incoming gas supply pressure must not exceed 14" water column for either type of gas.

The appliance was shipped from the factory ready for gas supply hook-up to the shutoff valve under the broiler. For disconnect, a manual valve must be located in the gas supply line upstream from the connector.

If the machine is installed on a moveable stand; (1) the installation shall be made with a connector that complies with the Standard for Connectors for Moveable Gas Appliances, ANSI Z21.69-1987, and Addenda, Z21.6a-1989, and a quick disconnect device that complies with the Standard for Quick-Disconnect Devices for Use With Gas Fuel, ANSI Z21.41-1989, and (2) adequate means must be provided to limit the movement of the appliance without depending on the connector and the quick-disconnect device or its associated piping to limit the appliance movement. (See figures on page 6.)

Note: Appliance installation must conform with all local codes, or in the absence of local codes, with the National Fuel Gas Code ANSI Z223.1-1988. Check all fittings for gas leaks, including

pilot tubing and inlet connections as soon as the appliance is connected to the gas supply.

Note: This appliance and its individual shutoff valve must be disconnected from the gas supply piping system during any pressure testing of that system at test pressures in excess of 1/2 psig (3.45 kPa).

Note: This appliance must be isolated from the gas supply piping system by closing its individual manual shutoff valve during any pressure testing of the gas supply piping system at test pressures equal to or less than 1/2 psig (3.45 kPa).

In Canada, installation shall be in accordance with CAN/CGA-B149.1 Natural Gas or CAN/CGA-B149.2 Propane Gas, and local codes where applicable.

By public initiative, the State of California has adopted legislation (Proposition 65) which requires manufacturers of many types of products, including gas appliances, to warn consumers of their products that contain chemicals or produce substances listed by the State of California to either cause cancer, birth defects, or other reproductive harm.

WARNING: If not installed, operated, and maintained in accordance with the manufacturer's instructions, this product could expose you to substances in fuel, or from fuel combustion which can cause cancer, birth defects, or other reproductive harm.

ELECTRICAL CONNECTION

Power requirements are stated on the unit nameplate and must be connected accordingly. Before starting broiler, tighten all electrical connections in control box. An electrical diagram is located inside the control box.

Note: This appliance must be electrically grounded in accordance with local codes or in the absence of local codes, the National Electrical Code, ANSI/NFPA No. 70-1990. In Canada, in accordance with the Canadian Electrical Code CSA 22.1 part 1, or local codes.

WARNING: This appliance should be connected with a four-pronged grounding plug for your protection against shock hazard. Be sure to plug directly into a properly grounded four-prong receptacle. Do not cut or remove grounding prong from plug.

Note: This appliance cannot be safely operated in the event of a power failure. No attempt should be made to operate during a power failure. Disconnect power supply before servicing.

PRE-OPERATION CHECK

Be sure that all parts are installed in the proper location. Refer to **OPERATION** section for lighting procedure. Start broiler and test for proper operation.

INSTALLING GAS APPLIANCE CONNECTORS AND FLEXIBLE GAS LINES CORRECTLY

For safety in the kitchen area, and to insure maximum service life, it is vitally important to correctly install connectors.

In order to avoid sharp kinks or excessive bends that could have a damaging effect on the connector, it may be necessary to attach pipe elbows in order to bring the connector into its proper plane. For easy movement of the appliance, the connector should be installed with a "lazy" loop for minimum tension.

Note: Gas appliances should be disconnected prior to maximum movement. (Minimal movement is possible to connect hose.)

WRONG

Avoid sharp bends and kinks when pulling equipment away from wall.

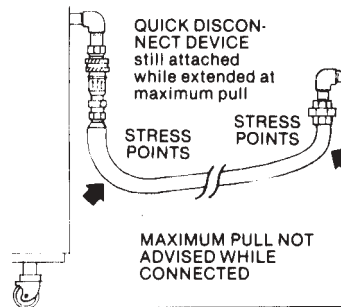

RIGHT

Minimum pull of equipment is permissible for accessibility to quick disconnect device.

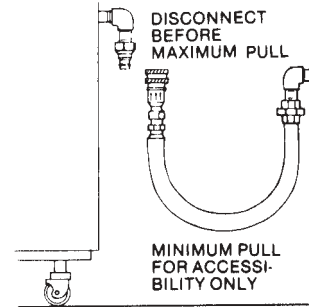

RESTRAINING DEVICE INSTALLATION AND USE

This high strength restrainer is to be used with all moveable (castered) appliances. It fully complies with American Gas Association requirements. References: Z21.69, Z83.11, and Z21.41 with current revisions. Installation is quick and positive. In Canada, device is in accordance with CAN 1-6.9-M70 Quick Disconnect Devices for use with gas fuel, and CAN 1-6.10-88 metal connectors for gas appliances.

Correct length for any appliance is simply a matter of loosening two adjuster clips (1) and re-tightening. (3" to 6" shorter than appliance connector is desired length.)

Restrainer is made of heavy duty steel cable, with a strong scissor hood (2) at one end, and an equally strong spring hook (3) at the other. Cotter pin (4) is supplied to secure the installation.

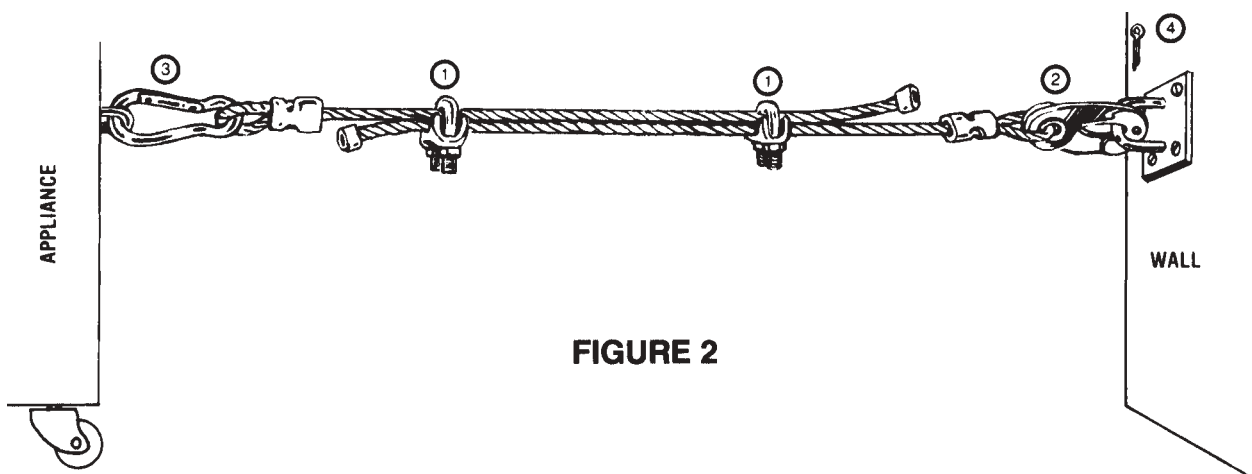
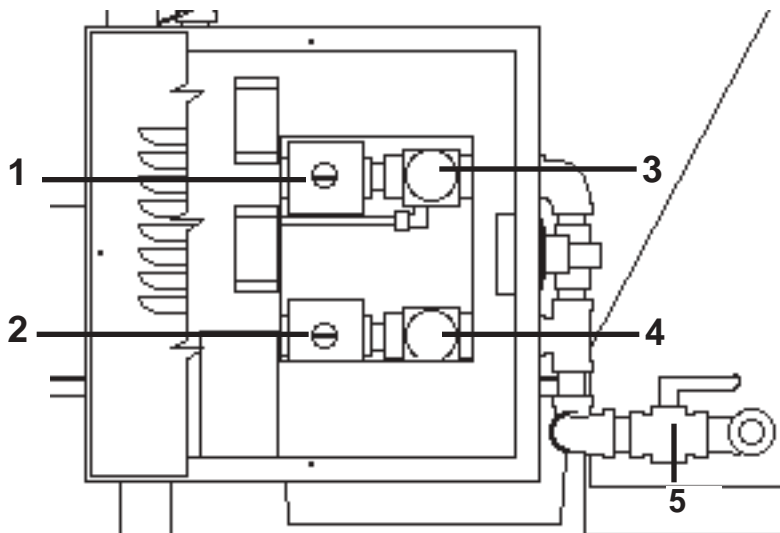
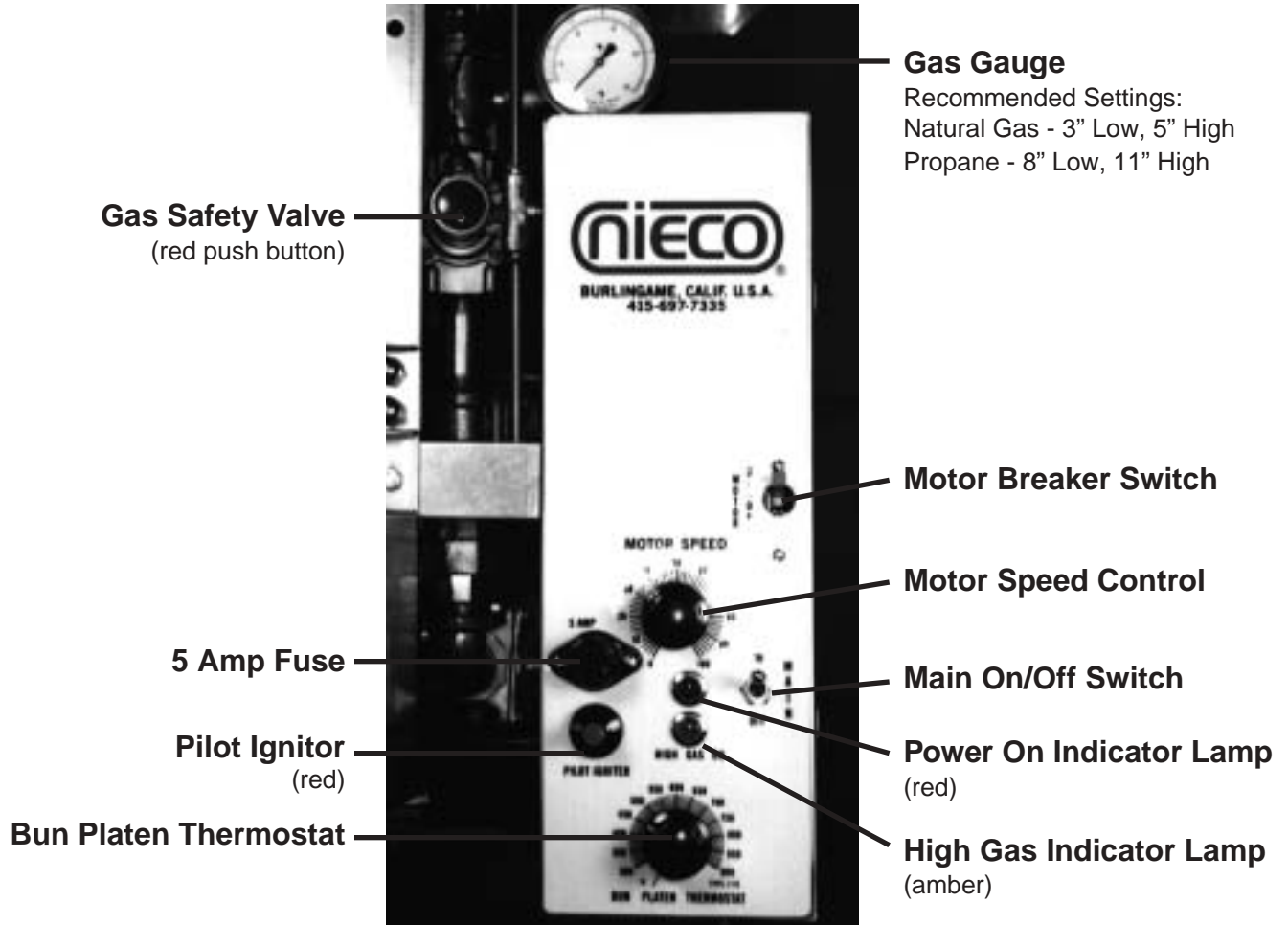

FIGURE 2

IMPORTANT: This Restraining Device should be ordered with every connector for Movable appliances.

C. OPERATION

Controls and Indicators



GAS SYSTEM CONTROLS

1. Main Gas Pressure Regulator.
Controls the gas pressure when the High Gas is off.
2. High Gas Pressure Regulator.
Controls the gas pressure in High Gas mode.
3. Main Gas Solenoid Valve.
4. High Gas Solenoid Valve.
5. Manual Gas Valve.
Valve is open when in line with pipe.

WARNING: Use extreme caution when making adjustments to the gas pressure regulator. Only authorized personnel should open the control box.

STEP-BY-STEP LIGHTING PROCEDURE

Before lighting, make sure that all parts are installed in the proper location, all controls are turned off, and the ventilation hood fan is turned on.

1. Turn on Main Power Switch.



2. Turn on Motor Switch.

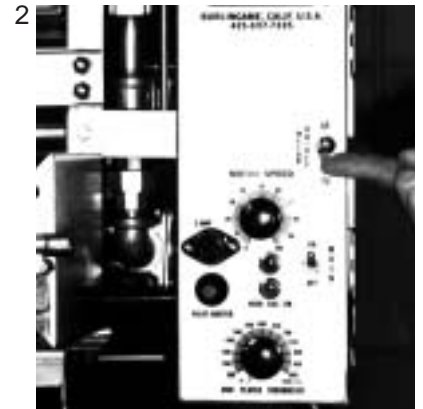

3. Set Motor Speed Control knob to desired setting. (BK Spec = 26 Links per Minute).



4. Set the Bun Platen Thermostat to the desired setting. (Use a setting of 450° F to start.)

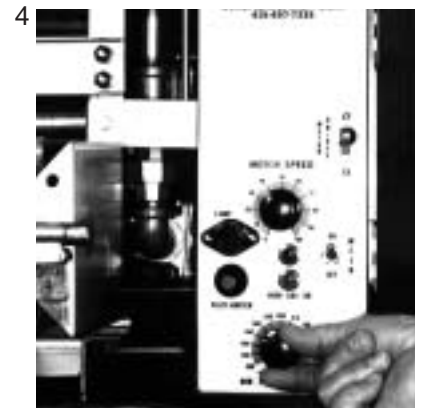

5. Open the Manual Gas Valve. The valve is open when the handle is in-line with the pipe.



6. Push and hold the Red Push Button Valve. This will start the flow of gas to the pilot lights. While holding in the Red Button, push the Ignitor button on the front of the control box. After the pilot lights, hold the Red Valve in for 30 seconds to allow the thermocouple to heat. When you release the Red Push Button, the burners should ignite. If the ignitor is not working, use a long-stem lighter to manually light the pilot.



7. After lighting the broiler, check the gas pressure to be sure it is adjusted to the levels stated on the machine rating plate. Allow the broiler at least 30 minutes to warm up.

SHUTDOWN PROCEDURE

For **EMERGENCY** shutdown, turn off the Main Power switch and shut off the manual gas valve. For **PLANNED** shutdowns - clear machine of all food products, turn the motor and main switches off.

CAUTION: Turn all appliance switches off before disconnecting cord from power supply.

AUTOMATIC TEMPERATURE CONTROL (ATC)

The Nieco Automatic Temperature Control (ATC) is a system that operates the broiler at two different energy input rates; a high energy input for initial warm-up and periods of high volume, and low energy for regular operation. This dual input rate and the ATC allow the broiler to operate at a very consistent temperature throughout the day and thus provide a very consistently broiled product. Since the broiler will remain on the lower input rate (low gas) most of the day, a substantial energy savings is realized.

The ATC consists of two gas pressure regulators piped in parallel, a solenoid valve in series with the high gas pressure regulator, a probe to sense the temperature at the loading end of the broiler, and a control unit which is operated by the signals from the probe. The control unit causes the solenoid valve to open and close. When the valve is open, the machine is in high gas mode, and the gas pressure is increased to heat up the broiler.

Under heavy product loads, the temperature sensed by the ATC probe will drop low enough to cause the ATC to open the solenoid valve. When the solenoid valve opens, the amber indicator light on the control panel will light. The ATC will keep the broiler on high pressure until the temperature sensed by the probe returns to the calibrated setting.

CALIBRATING THE ATC

1. Loosen the control knob lock screw and set the ATC control knob to 600° F.
2. Turn on the Main Power Switch.
3. Turn on the Motor Power Switch.
4. Light the broiler following the procedure in this manual.
5. The broiler should be in high gas mode at this time. (Amber light on.)
6. When the broiler reaches 600°, the high gas will shut off, and the broiler will be in low gas.
7. 30 minutes after lighting the broiler, **slowly** turn the ATC control knob up (clockwise) until the high gas clicks on. This is the idle temperature of the broiler.
8. As soon as the high gas turns on (there will be an audible “click”), slowly turn the ATC down (counter clockwise) 10° to 20° below the point where the high gas clicks on.
9. The control knob setting may need a minor adjustment on the first day of use, in order to maintain 10° to 20° below the normal idle temperature. Once the adjustment is correct, it need not change from day to day unless the broiler operating conditions change.
10. After all adjustments have been made, tighten the control knob lock screw to prevent accidental movement.

WARNING

Never set the ATC control knob at a setting high enough to keep the broiler continuously in high gas pressure. The machine may be damaged, energy costs will be much higher, and some broiler parts may wear out prematurely.

BUN GRILLING PLATEN

The 980, 950 and 930 are equipped with independently adjustable dual bun grilling platens. The clearance of each platen is adjusted by turning the black handles located directly above the platens, at the feed end of the machine. Frequent adjustment should not be necessary.

FOOD PREPARATION, COOKING, AND HANDLING PRACTICES

Established guidelines for safe food preparation, cooking, and handling should be adhered to rigidly. The Nieco Automatic Broiler is very consistent in cooking. Check the temperature of the meat cooked frequently to assure that the broiler is set up properly.

D. ASSEMBLY/DISASSEMBLY AND CLEANING

If this appliance is connected to the gas supply by a flexible gas line and quick disconnect coupling, it must also be connected to a restraining device (see installation instructions). If the appliance is moved and then returned to its original position, it must be reconnected to the restraining device and the casters locked before resuming operation.

1. Clear machine of all food products. Allow the machine to run empty for ten minutes in order to burn off the residue on the belt. Turn Main Power and Motor switches off. Allow the machine to cool before you disassemble.

2. Remove the Side Panels by lifting up and off. Wipe clean with a degreaser.

FROM THE FRONT OF THE BROILER

3. Remove the Patty Feeder by lifting up and out. Clean daily using soap and water.

4. Remove the Upper Burner Front Reflector, and clean with soap and water.

5. Remove the Grease Pan by sliding it out the front. Clean daily using soap and water.

6. Remove the Belt Scraper. Notice the position it sits in before removing, so that you can replace it properly. Clean daily using soap and water or degreaser.

7. Scrape the shafts with the special tool provided, or with a flat head screwdriver.

FROM THE LEFT SIDE OF THE BROILER

8. Remove the Grease Chute and Grease Box, and clean using soap and water.

2



3



4



5



6



7



8



9. Remove the Burner Access Cover.

9



10. Slide the Lower Burners out and remove the Protective Shields. Clean the shields by scraping off any built up residue, then soak in soap and water. **Clean the shields daily. This will help to prolong the life of the burner and keep the broiler cooking properly.**

10



FROM THE BACK OF THE BROILER

11. Remove the awning by lifting up and off. Clean using soap and water.

11



12. Remove the Patty Discharge Pan and Insert. Clean daily using hot soapy water, and sanitize.

12



13. Remove the Stripper Blade. Scrape any built up residue from the blade. Clean by soaking in soap and water. Sanitize.

13



14. Remove the Lower Burner Reflector. Notice the position of the piece before removing it, so that you can re-install it properly. Clean by soaking in soap and water.

14



WEEKLY CLEANING

In addition to the daily cleaning, perform these steps on a weekly basis.

1. Remove the Upper Burners and clean as following the steps outlined below (see A,B & C).
2. Clean all Pilot Burners and Main Burner Orifices with rubbing alcohol and a pipe cleaner.
3. Remove all grease and carbonized build-up from the interior of the broiler. Do not spray anything (i.e. oven cleaner) inside the broiler.

1



REPLACE REVERBERATOR AT THE FIRST SIGN OF BREAKAGE.

A. Remove Reverberator and clean with a stiff bristle brush.



B. Clean Burner Screen with a stiff bristle brush.

HOLD BURNER WITH THE SCREEN FACING DOWN WHILE BRUSHING.

This prevents particles from dropping down and lodging inside the burner.



C. Clean Burner Venturi with a stiff bristle brush.

HOLD BURNERS SO THAT PARTICLES WILL NOT DROP INSIDE.

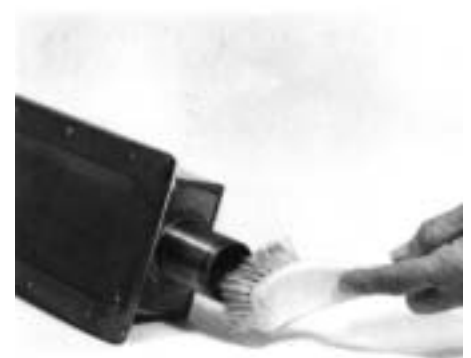

DO NOT SOAK OR SUBMERGE THE BURNERS IN WATER. WATER CAN CAUSE IMPROPER BURNER PERFORMANCE.

E. CONVEYOR BELT REMOVAL

Before beginning, notice the way the belt runs through the broiler. Also notice the direction the knuckles face. Be sure to re-assemble in the same way.

1. Run belt until the Master Link is near the front idler shaft.

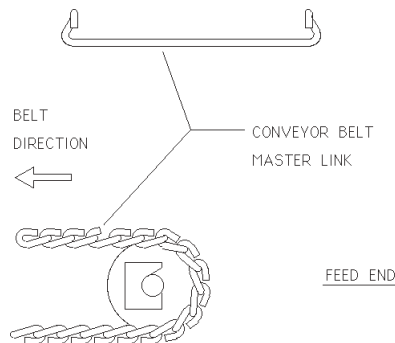

2. Lift shaft and Teflon Blocks up, and slide the blocks out.



3. Unhook the Master Link.



To reassemble, reverse the procedure. Be sure to reassemble the belt with the knuckle opening facing away from the direction of travel.

F. CONVEYOR BELT TENSION

Maintain proper tension on the conveyor belts to prevent jamming. Bearing spacers (pictured below) are supplied with the broiler to make minor tension adjustments. Major tension adjustments are made by removing a link or links from the belt.

The diagram on the left shows the spacer in the stored position. The diagram on the right shows the spacer behind the teflon bearing tightening the belts.

Belt tension should be checked monthly. To do this, allow the machine to cool, then grip the idler shaft at each end and pull on it. If the shaft and bearings move 3/16" or more, the spacers should be placed behind the bearings to tighten the belts. If the spacers are already behind the bearings, return them to the stored position and remove a link from the conveyor belt.

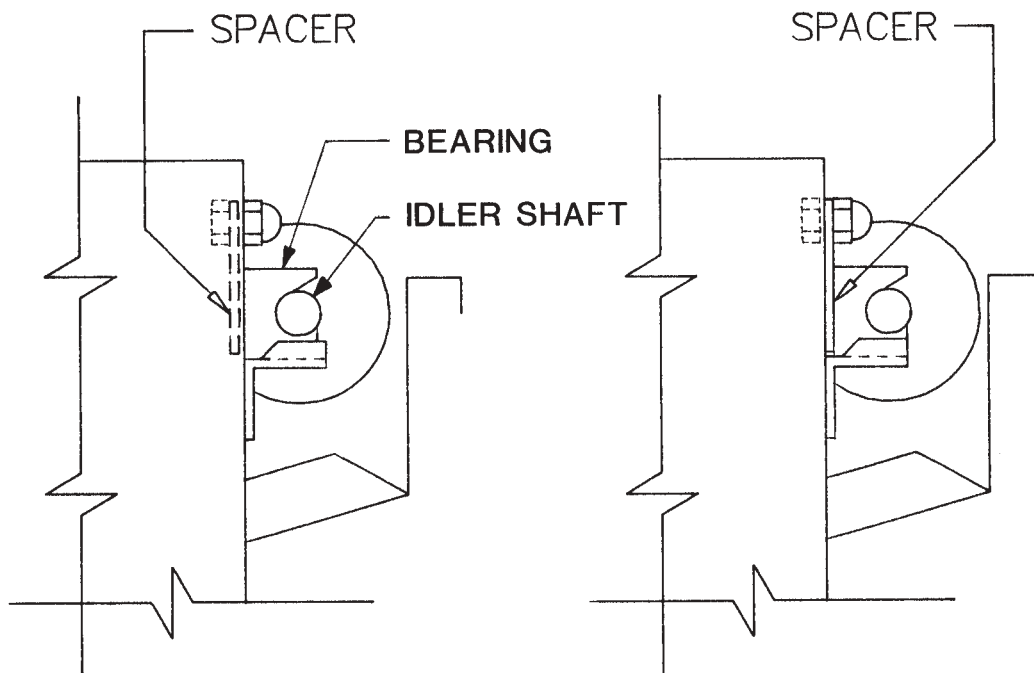

BROIL BELT PROBLEMS

Interference with stripper blade:

The most common belt problem to be expected is the physical interference of the belt with the stripper blade. This is caused by bent or warped rods on the meat belt, and can be fixed by replacing the rods that are causing the problem. Other causes are bent stripper blades, or utensils jammed in the belt.

Blocked belts:

When trouble shooting drive problems, it is important to ensure that the belt is not being blocked. To do this, detach the drive chain and turn the meat belt by hand. The belt, with the motor detached, should turn freely and easily. If the blockage has occurred which is preventing the belt from turning, the blockage should be removed before the drive chain is re-attached. The drive chain can be easily removed from the drive sprocket (on the motor shaft) by loosening the mounting bolts and raising the motor.

G. PARTS AND LOCATION

Model 980 Gas - Feed End View

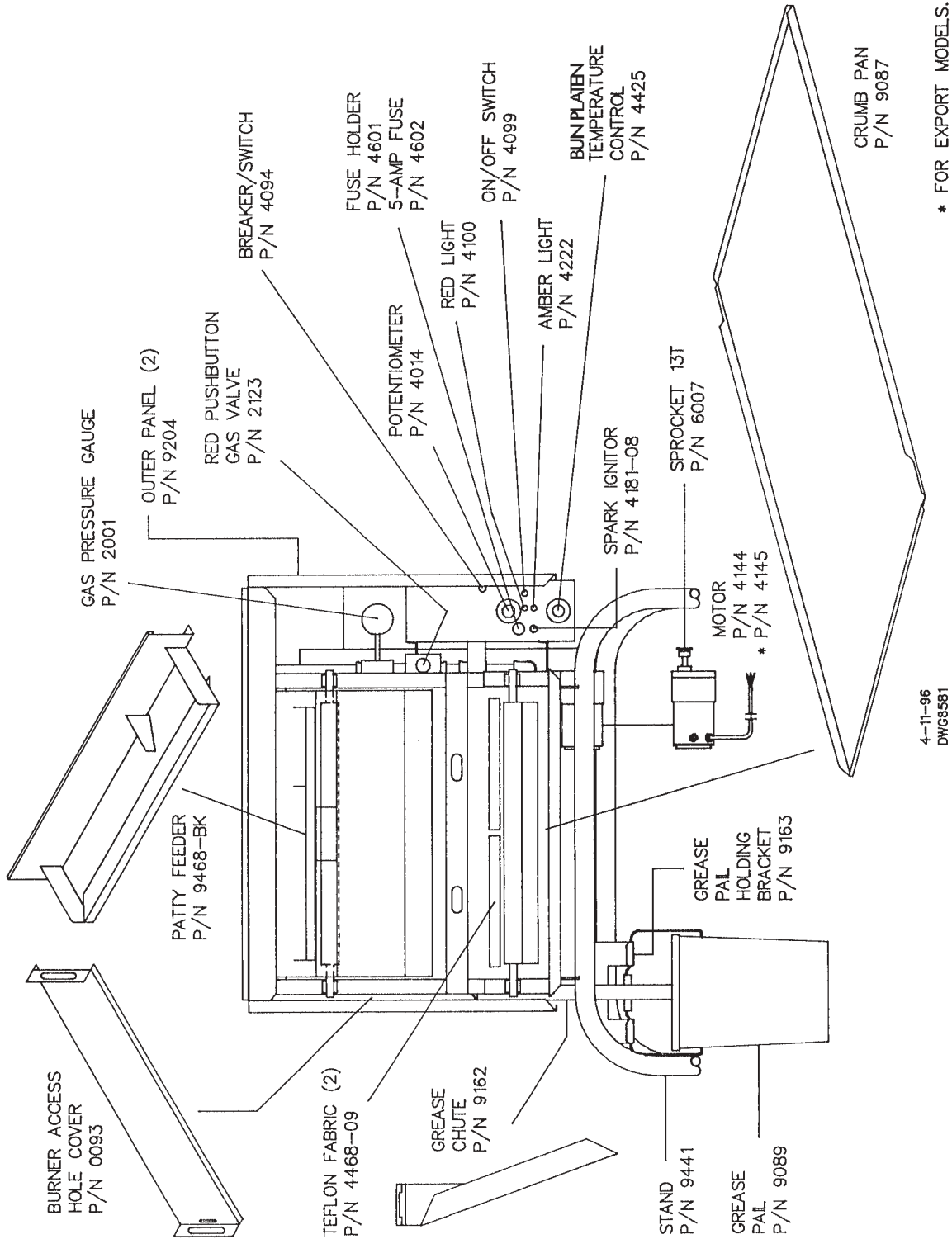

4-11-96
DWG8581

* FOR EXPORT MODELS.

G. PARTS AND LOCATION

Model 980 Gas - Left Side View

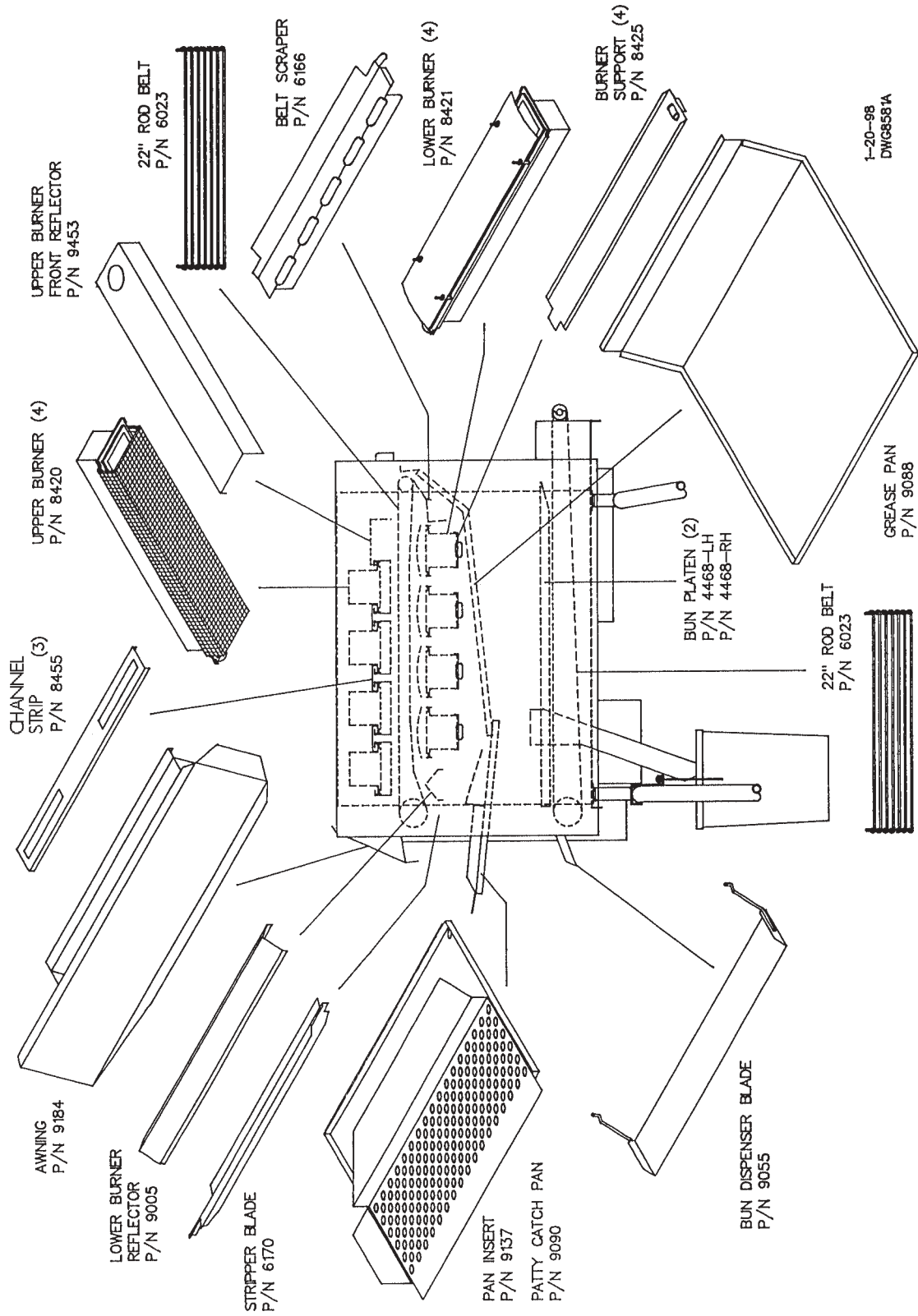

G. PARTS AND LOCATION

Model 980 Gas - Right Side View

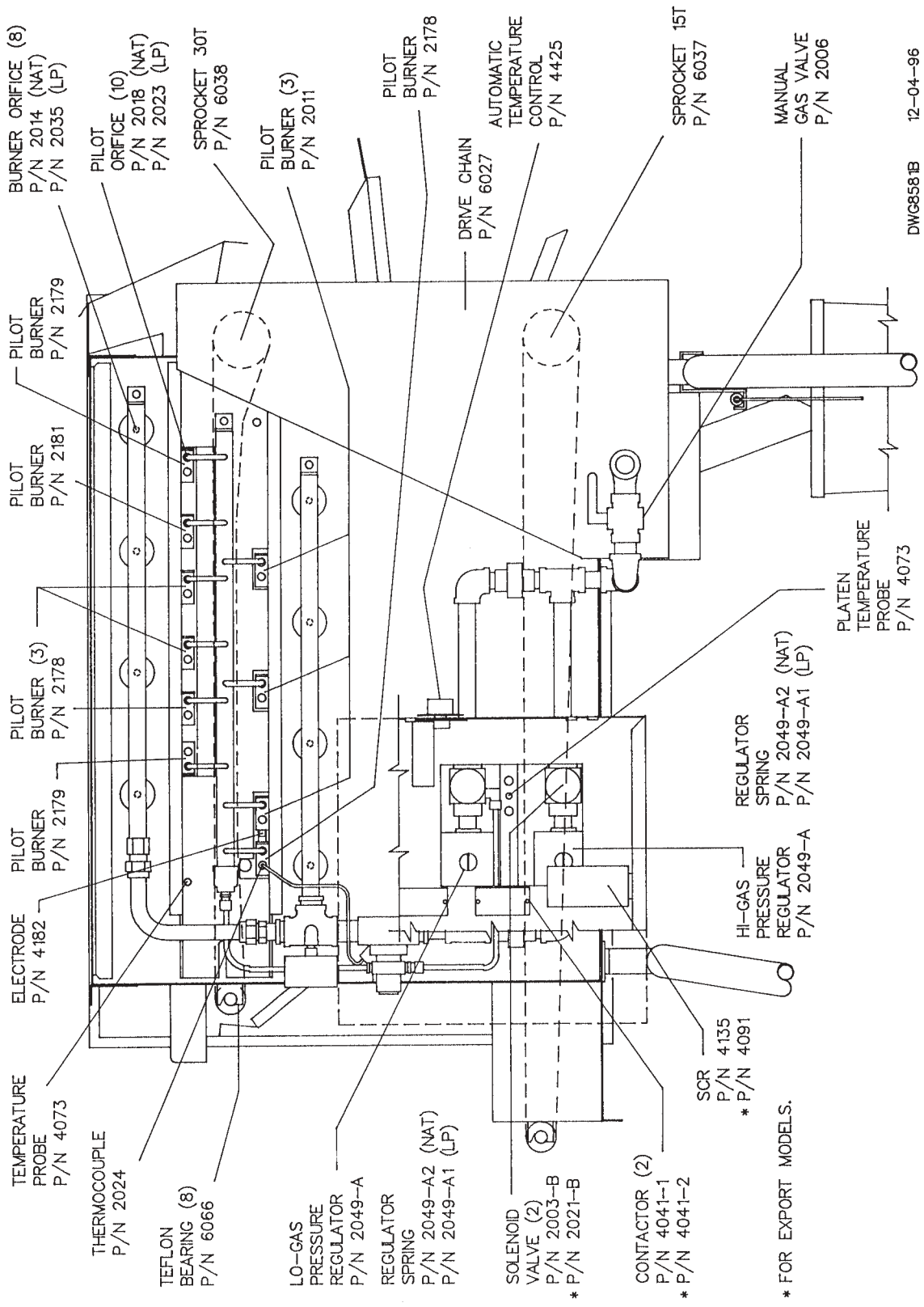

* FOR EXPORT MODELS.

G. PARTS AND LOCATION

Model 950 Gas - Feed End View

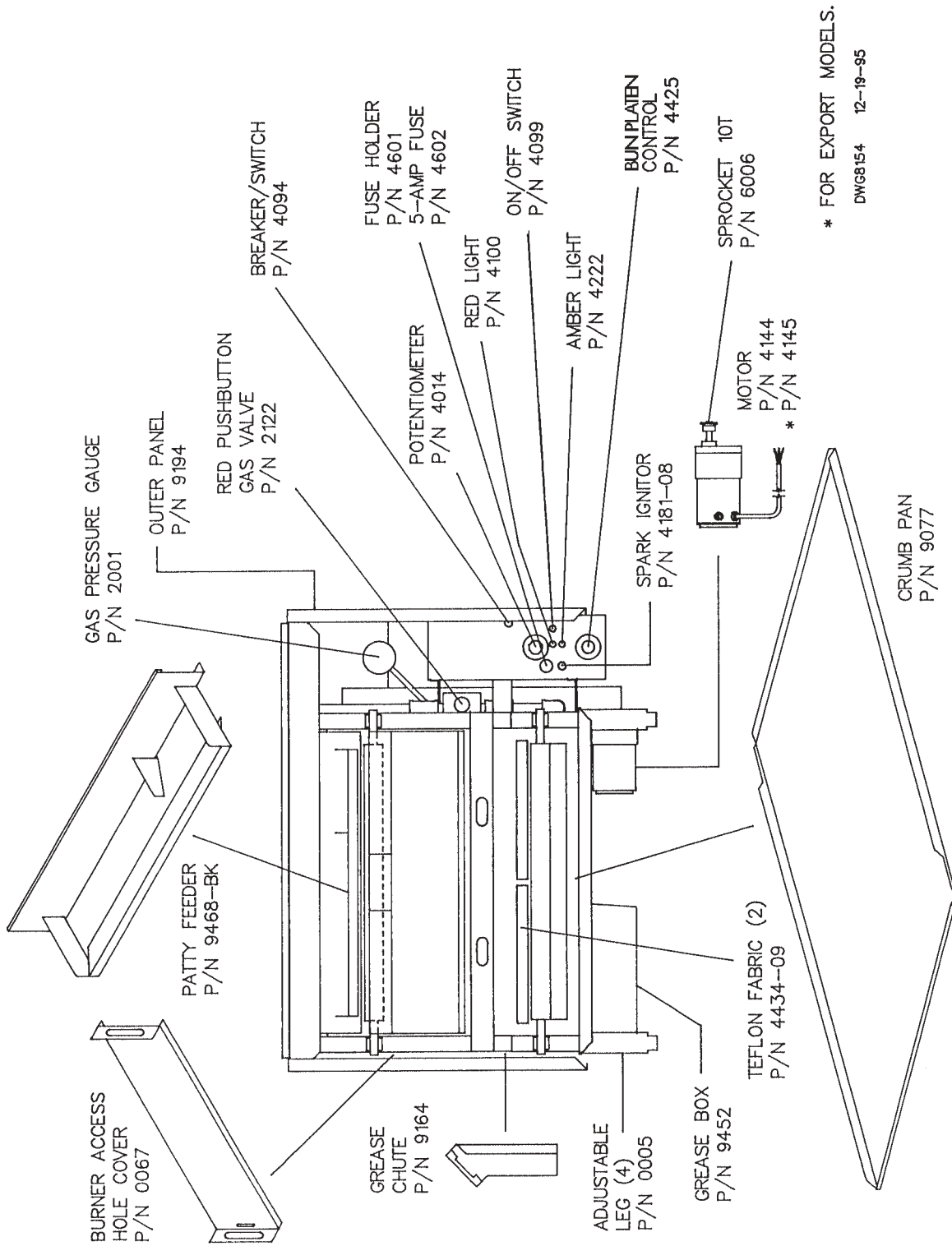

* FOR EXPORT MODELS.

DWG8154 12-19-95

G. PARTS AND LOCATION

Model 950 Gas - Left Side View

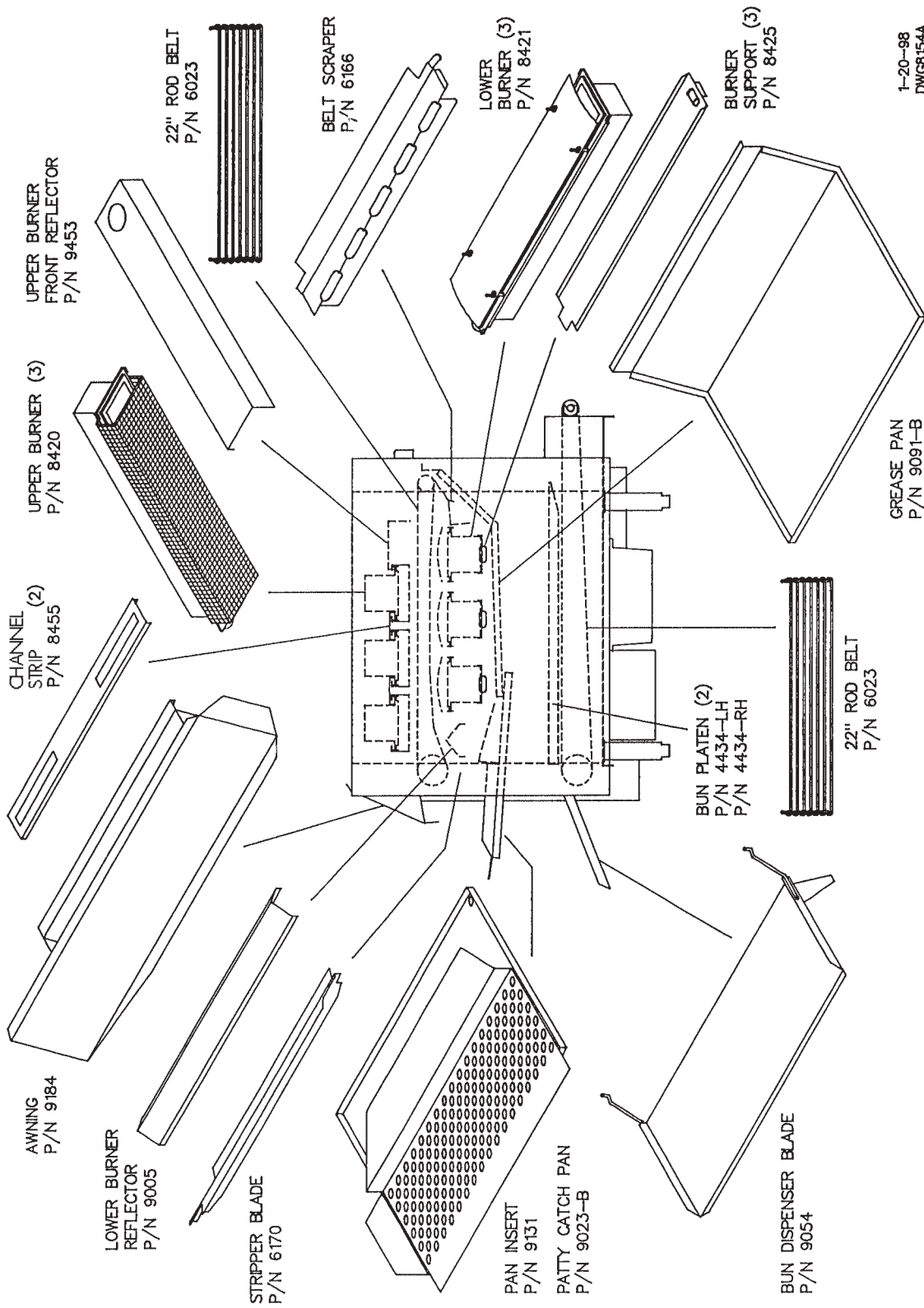

1-20-98
DWG8154A

G. PARTS AND LOCATION

Model 950 Gas - Right Side View

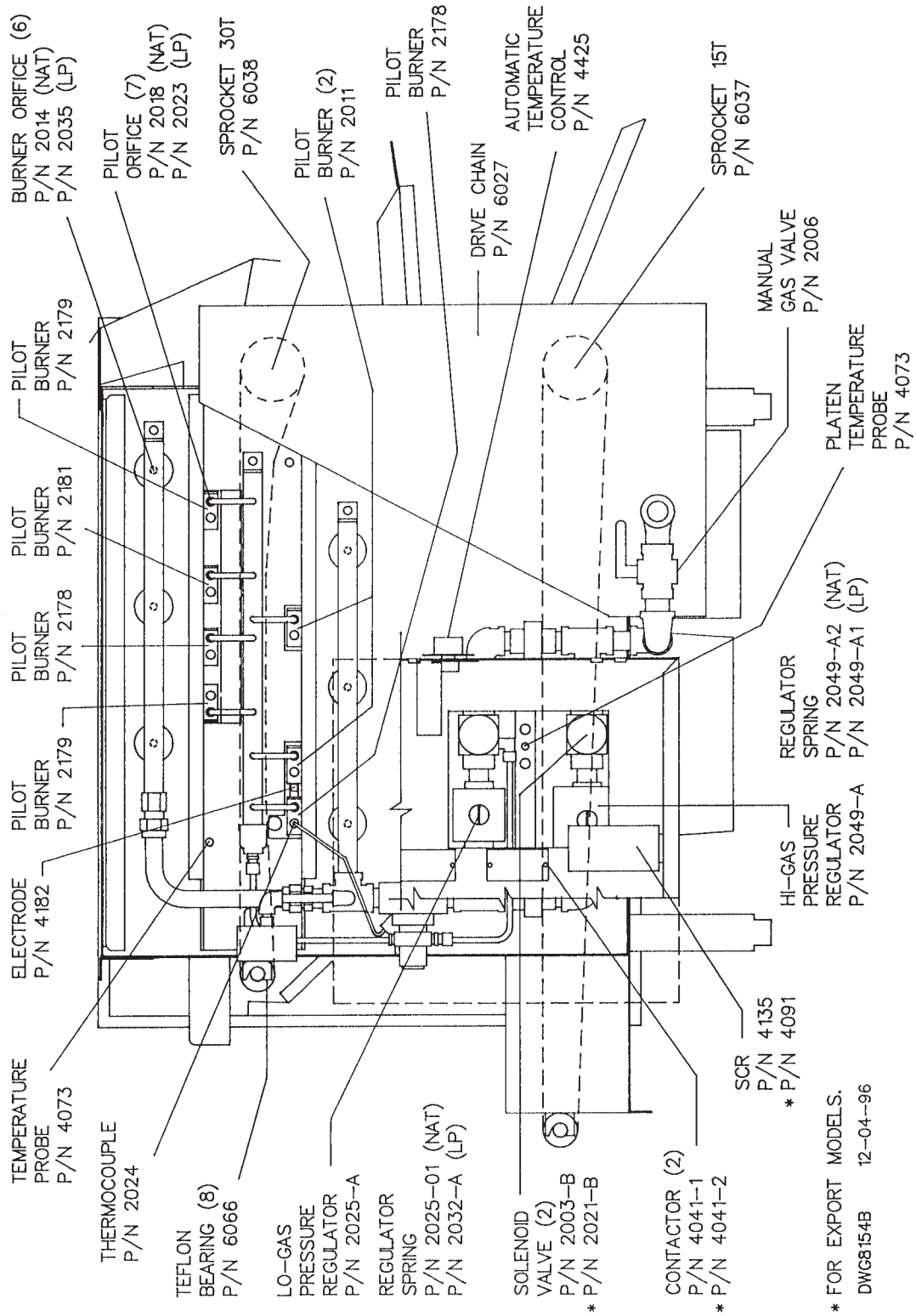

* FOR EXPORT MODELS.
 DWG8154B 12-04-96

G. PARTS AND LOCATION

Model 930 Gas - Feed End View

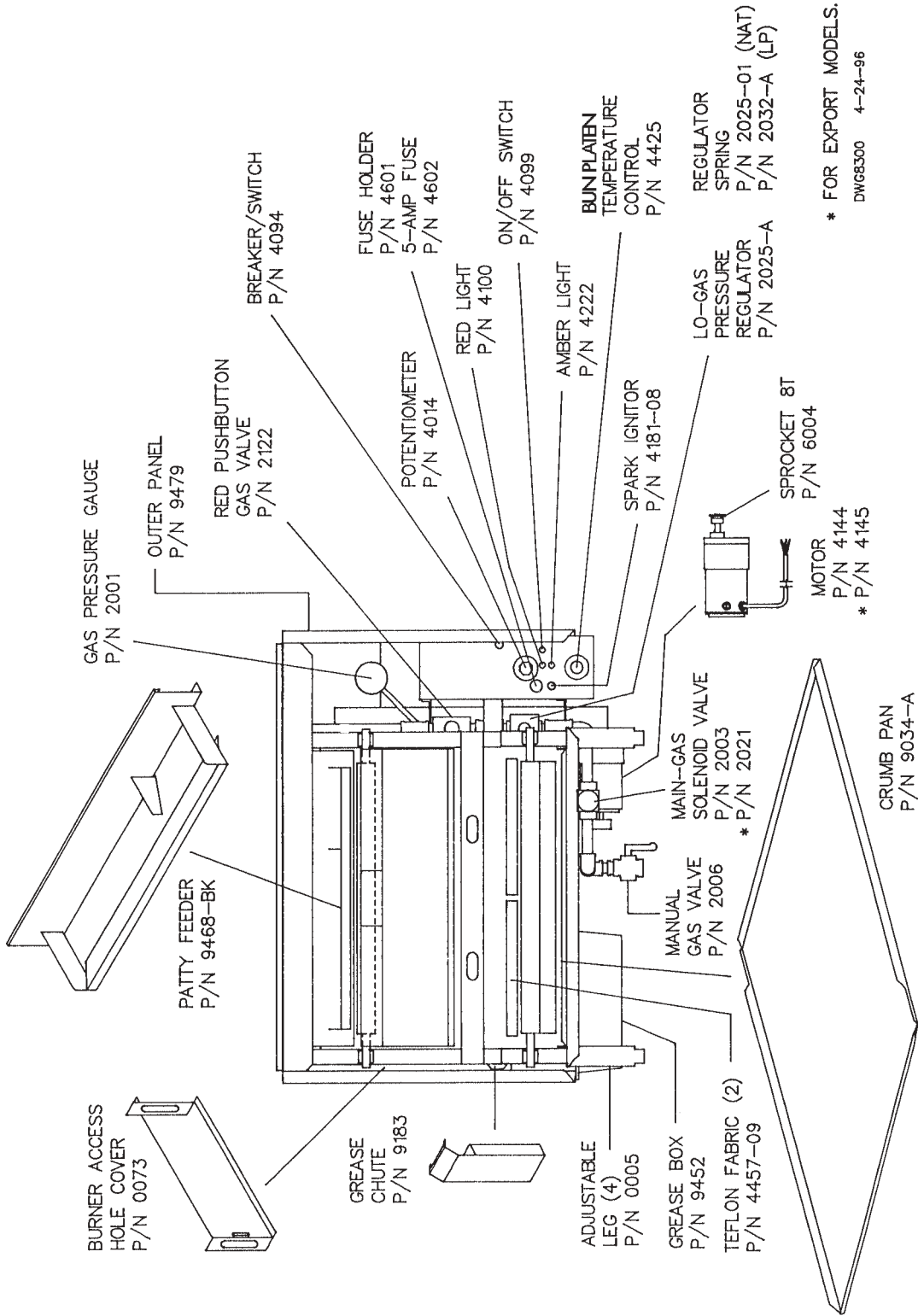

* FOR EXPORT MODELS.

DWG68300 4-24-96

G. PARTS AND LOCATION

Model 930 Gas -Left Side View

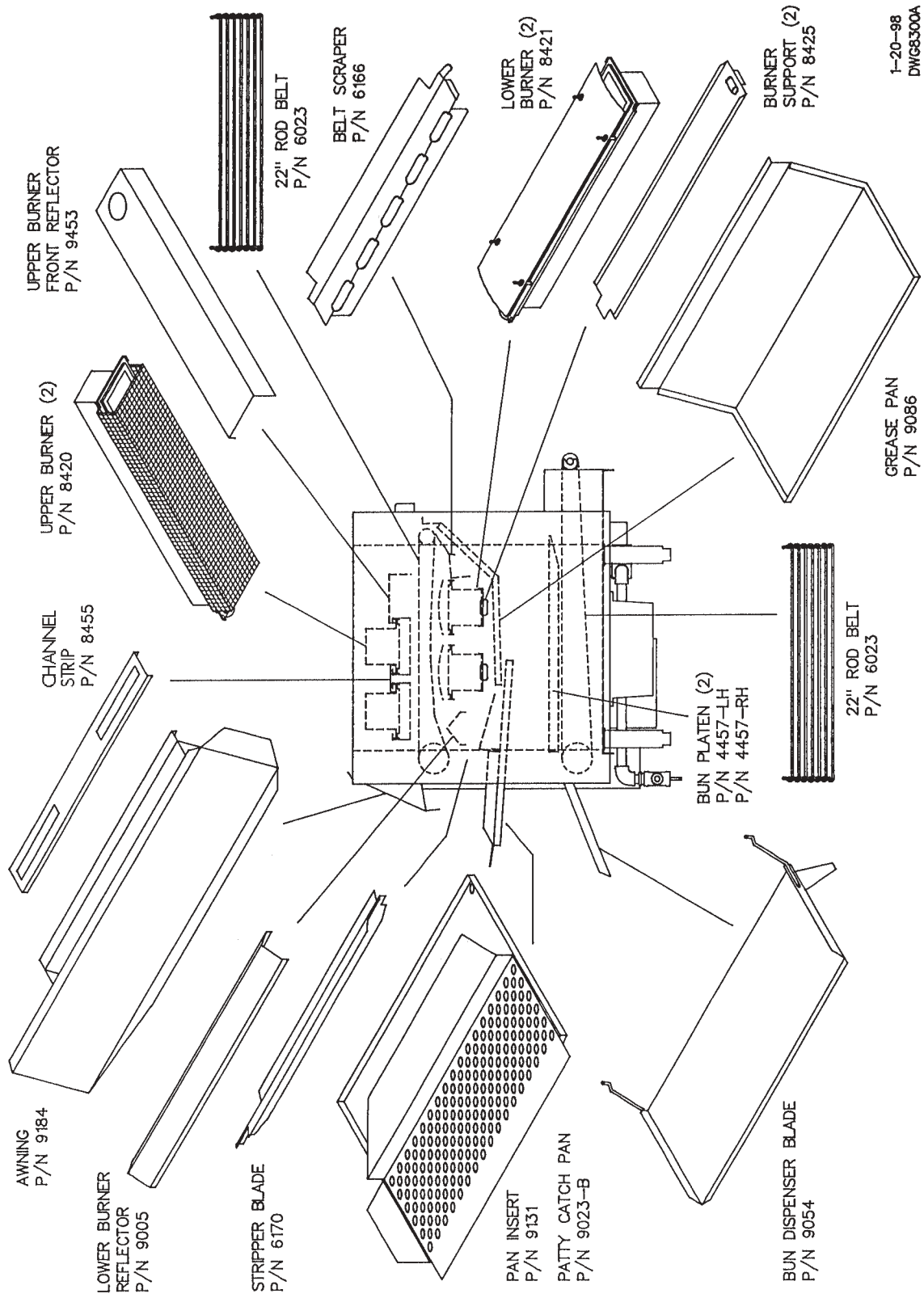

1-20-98
DWG8300A

G. PARTS AND LOCATION

Model 930 Gas - Right Side View

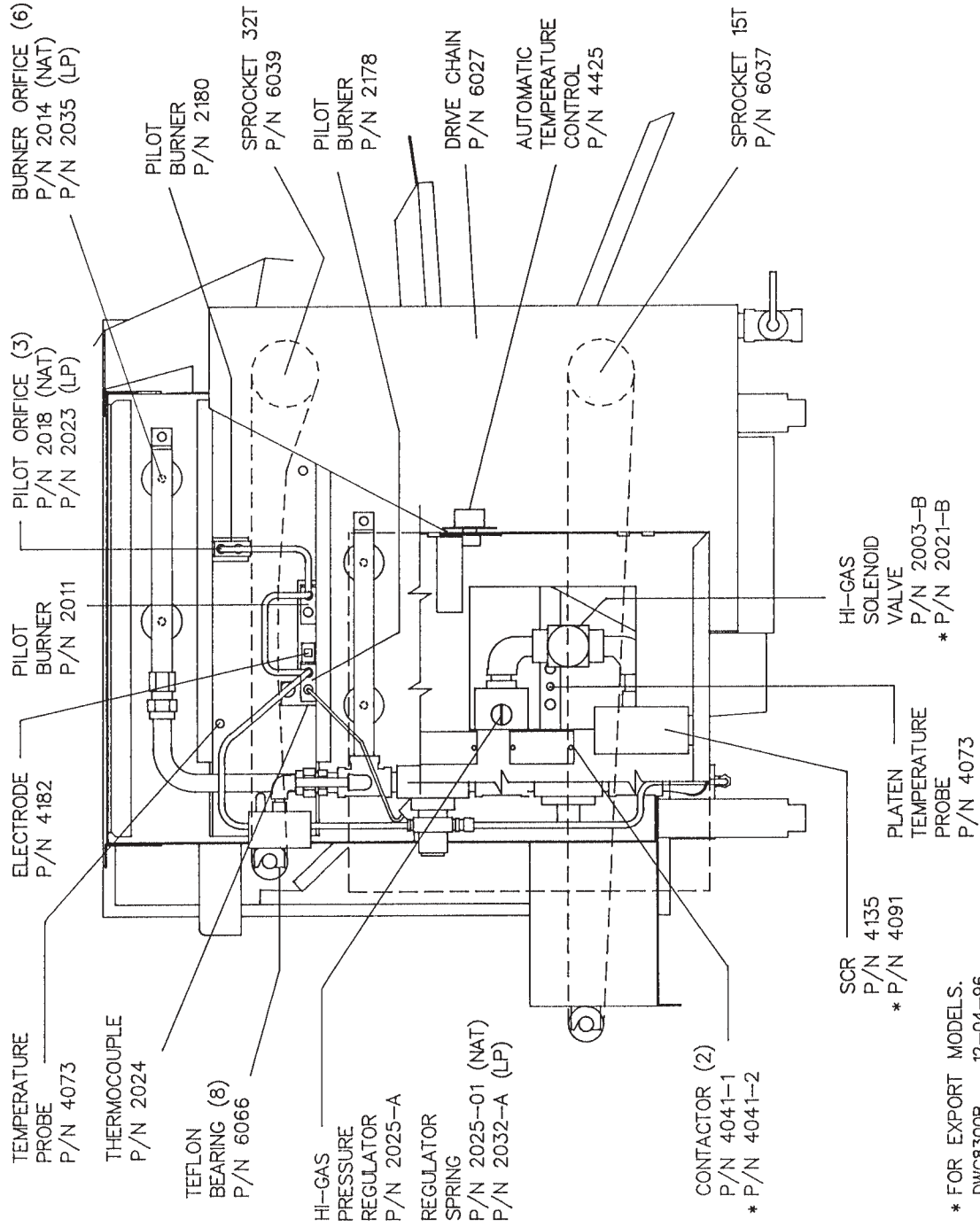

* FOR EXPORT MODELS.
 DWG8300B 12-04-96

H. Troubleshooting Guide

PROBLEM	PROBABLE CAUSES	SOLUTION
Pilot Burners won't light.	<ol style="list-style-type: none"> 1. Pilot Burner dirty, or orifice plugged. 2. Push button valve not fully depressed. 3. Air in pilot line. 4. Electric spark ignitor dislocated. 5. Electric power not on, or machine not plugged in. 6. Gas not hooked up or on. 	<ol style="list-style-type: none"> 1. Clean pilot burner, replace orifice. 2. Repeat start-up procedure. 3. Purge line by holding down red push button before igniting. 4. Position white electrode so the tip is 1/4" from the pilot burner, or light manually. 5. Plug in/turn on. 6. Check Gas Supply
Pilots won't stay lit when push button is released.	<ol style="list-style-type: none"> 1. Thermocouple not hot yet. 2. Weak pilot flame. 3. Thermocouple dirty or defective. 4. Push button power unit defective. 	<ol style="list-style-type: none"> 1. Repeat starting procedure, and hold the push button in longer. 2. See Below. 3. Clean or replace. 4. Replace.
Pilot flame weak or yellow.	<ol style="list-style-type: none"> 1. Dirty pilot or orifice. 2. Pilot tubing plugged or pinched off. 3. Incoming gas pressure too low. 	<ol style="list-style-type: none"> 1. Clean or replace. 2. Check line. Pilot tubing can be removed with a wrench. 3. Adjust pressure regulator.
Main Burners won't light, or they go out during operation.	<ol style="list-style-type: none"> 1. Pilot flame too small. 2. Air draft blowing pilot flame out. 3. Electrical supply interruption. 	<ol style="list-style-type: none"> 1. Replace pilot orifice. See Above. 2. Check for drafts. 3. Secure power supply.
Burner appears dim (cooler).	<ol style="list-style-type: none"> 1. Burner orifices dirty. 2. Gas pressure too low. 3. Gas line partially blocked. 4. Pressure regulator defective. 5. Burners not installed properly. 6. Burner venturi dirty. 7. Main gas valve partially closed. 8. Burner distributor screen dirty. 	<ol style="list-style-type: none"> 1. Clean or replace. 2. Adjust pressure regulator. 3. Check line and clear. 4. Replace. 5. Remove and install properly. 6. Clean. See Cleaning Instructions. 7. Open fully so that handle is in line with the valve. 8. Clean.
Burners backfire or sputter.	<ol style="list-style-type: none"> 1. Gas pressure too high. 2. Burners have gotten wet. 3. Burner venturi dirty. 	<ol style="list-style-type: none"> 1. Adjust pressure regulator. 2. Dry thoroughly, replace gasket. 3. Clean.
Conveyor belts won't advance.	<ol style="list-style-type: none"> 1. Machine not plugged in. 2. Wall circuit breaker off. 3. Motor control switch off. 4. Motor speed control not set properly. 5. Speed control pot. or SCR defective. 6. Drive chain broken. 7. Gear motor defective. 8. Loose or broken wire. 9. Motor unplugged. 10. Drive sprocket loose. 	<ol style="list-style-type: none"> 1. Plug in. 2. Turn on. 3. Turn on. 4. Reset cook time. 5. Replace. 6. Replace or repair. 7. Replace. 8. Tighten or replace. 9. Plug in. 10. Tighten sprocket set screw.

PROBLEM	PROBABLE CAUSES	SOLUTION
Motor control switch trips.	<ol style="list-style-type: none"> 1. Conveyor belt jammed 2. Switch defective. 3. Drive chain binding. 4. Shorted wire to motor. 5. Gear motor defective. 	<ol style="list-style-type: none"> 1. Remove jam, reset switch. 2. Replace. 3. Adjust tension of chain. 4. Repair wire. 5. Replace.
Conveyor belt speeds are erratic.	<ol style="list-style-type: none"> 1. Drive chain binding. 2. Gear motor defective. 3. Loose drive sprockets. 	<ol style="list-style-type: none"> 1. Adjust tension of chain. 2. Replace. 3. Tighten set screws.
Broiled product over or under cooked.	<ol style="list-style-type: none"> 1. Wrong conveyor belt speed. 2. Product temperature not consistent. 	<ol style="list-style-type: none"> 1. Reset cook time. 2. Be sure refrigerators and freezers are working and that product temperature is consistent.
Bun Platen won't heat.	<ol style="list-style-type: none"> 1. Wall circuit breaker off. 2. Main power switch off. 3. Defective thermostat. 4. Defective platen contactor. 5. Loose or broken wire. 6. Machine not plugged in. 7. Thermostat turned off. 8. Inadequate voltage. 	<ol style="list-style-type: none"> 1. Turn on. 2. Turn on. 3. Replace. 4. Replace. 5. Tighten or repair. 6. Plug in. 7. Turn on. 8. Check power supply.
Bun platen gets warm but not hot..	<ol style="list-style-type: none"> 1. Thermostat setting too low. 2. Thermostat defective. 3. Platen defective. 4. Power cord not fully plugged in. 	<ol style="list-style-type: none"> 1. Increase setting. 2. Replace. 3. Replace. 4. Plug in and twist.
Bun platen gets too hot.	<ol style="list-style-type: none"> 1. Thermostat setting too high. 2. Sensing bulb not fully inserted into platen. 3. Thermostat defective. 4. Water in control. 	<ol style="list-style-type: none"> 1. Decrease setting. 2. Insert bulb fully into platen. Bulb is located on the control box side of the platen. 3. Replace. 4. Allow to dry then cycle off and on.
Hamburger patties stick to belt.	<ol style="list-style-type: none"> 1. Stripper blades not adjusted properly. 2. Product under broiled. 3. Product too lean. 4. Product too thin. 5. Burners not hot enough. 6. Heat reflectors not installed, or installed improperly. 7. Patty feeder adjusted too low. 8. Patty belt too tight. 9. Warped links in the patty belt. 	<ol style="list-style-type: none"> 1. Adjust. 2. Slow belt speed. 3. Check meat - 23% fat, scored both sides. 4. Try thicker patties. 5. Check burners, see above. 6. Be sure all reflectors are installed properly. Refer to parts and location section. 7. Raise by moving the hanging bolts up. 8. Loosen tension. 9. Replace warped links.

I. SPECIFICATIONS

Model 980

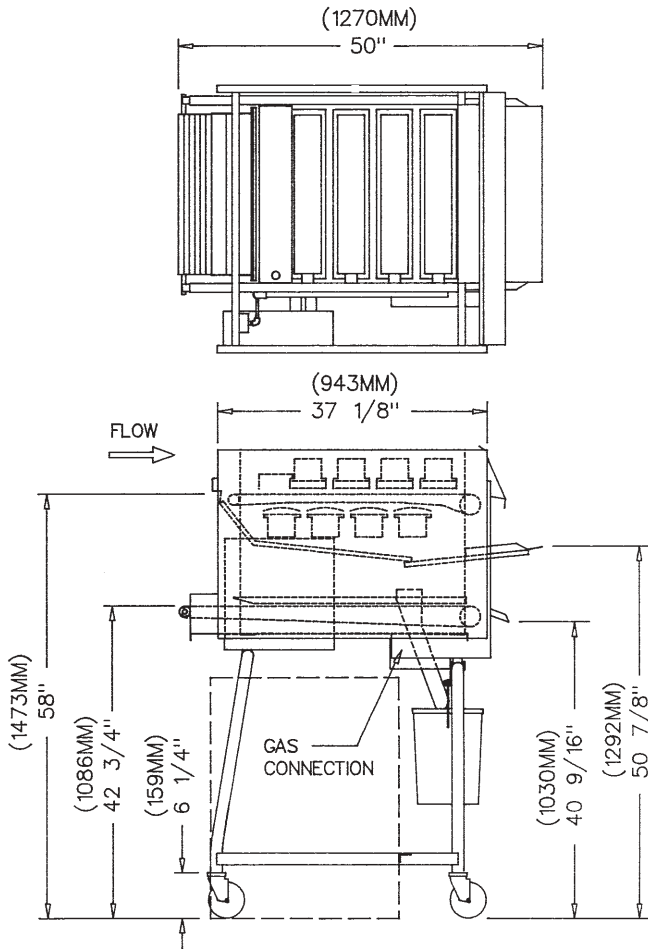

Weight	LB	KG
APPROXIMATE	545	247
SHIPPING	715	324

Exhaust	CFM	CMH
TYPICAL	1100	1869

Dimensions	INCH	MM
LENGTH	50	1270
HEIGHT	64 1/2	1638
WIDTH	36 3/4	933

Energy - Gas Model

GAS CONNECTION	3/4" N.P.T.
ELECTRICAL CONNECTION	208-240V/120V 1Ø
(SPECIFY EXACT VOLTAGE)	50/60 Hz 21A
AVG. KW/HR	2.2

NATURAL GAS	3" W.C.	5" W.C.
BTU/HR	106,000	- 132,000
KCAL/HR	26,173	- 32,593

PROPANE	8" W.C.	11" W.C.
BTU/HR	106,000	- 132,000
KCAL/HR	26,173	- 32,593

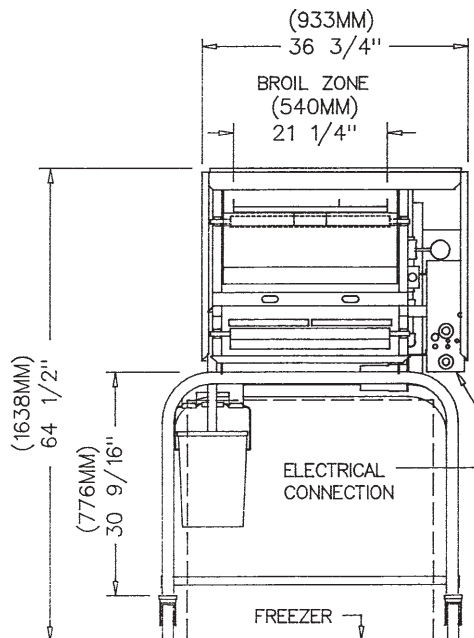

Model 930 Gas

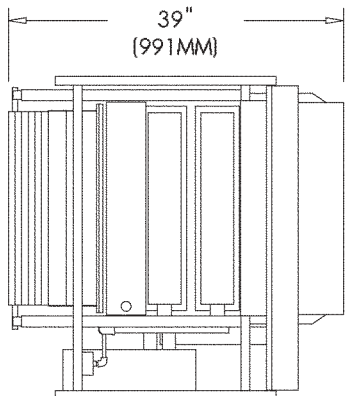
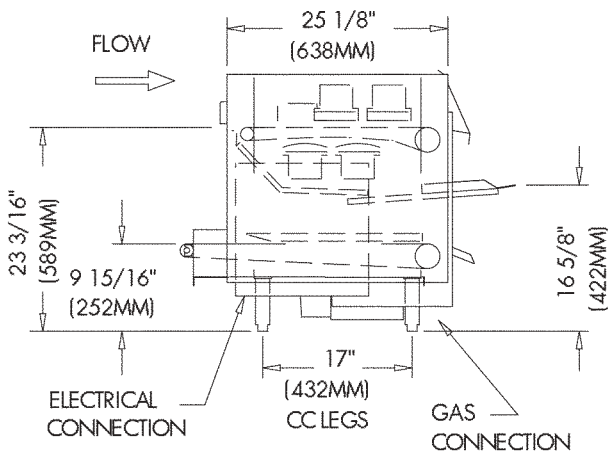
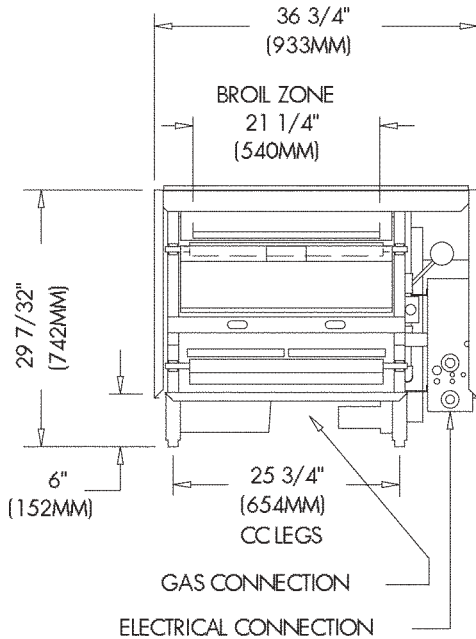

Weight

APPROXIMATE **LB** **KG**
 395 179

Exhaust

TYPICAL **CFM** **CMH**
 600 1020

Dimensions

INCH **MM**
 LENGTH 39 991
 HEIGHT 29 7/32 742
 WIDTH 36 3/4 933

Energy - Gas Model

GAS CONNECTION 1/2" N.P.T.
 ELECTRICAL CONNECTION 208-240V/120V 1Ø
 (SPECIFY EXACT VOLTAGE) 50/60 Hz 13A
 AVG. KW/HR 1.4

NATURAL GAS 3" W.C. 5" W.C.
 BTU/HR 54,000 - 70,000
 KCAL/HR 12,350 - 15,880

PROPANE 8" W.C. 11" W.C.
 BTU/HR 54,000 - 70,000
 KCAL/HR 13,608 - 17,640

J. WIRING DIAGRAM

930, 950, 980 Gas - Export

REV	DESCRIPTION	DATE	BY
A	DELETE DIGITAL DISPLAY. ADD MODEL NO.'S	12-9-74	DZ
B	DELETE OPTIONAL SED MOTOR. I/SCR/PT/5W.	2-7-75	DZ
C	DEL. RESET, ADD 'N' BLOCK, CHG. 'N' TO BLU; ADD SEP. 146A WIRE; 640P PLATEN; 5-3/45	5-3/75	DZ
D	CHANGE TEMP. CONTROL, ADD MODEL NO.'S. W/IS [D1] "TRAKSTAT" P/N 4071-P	11-2-75	DZ

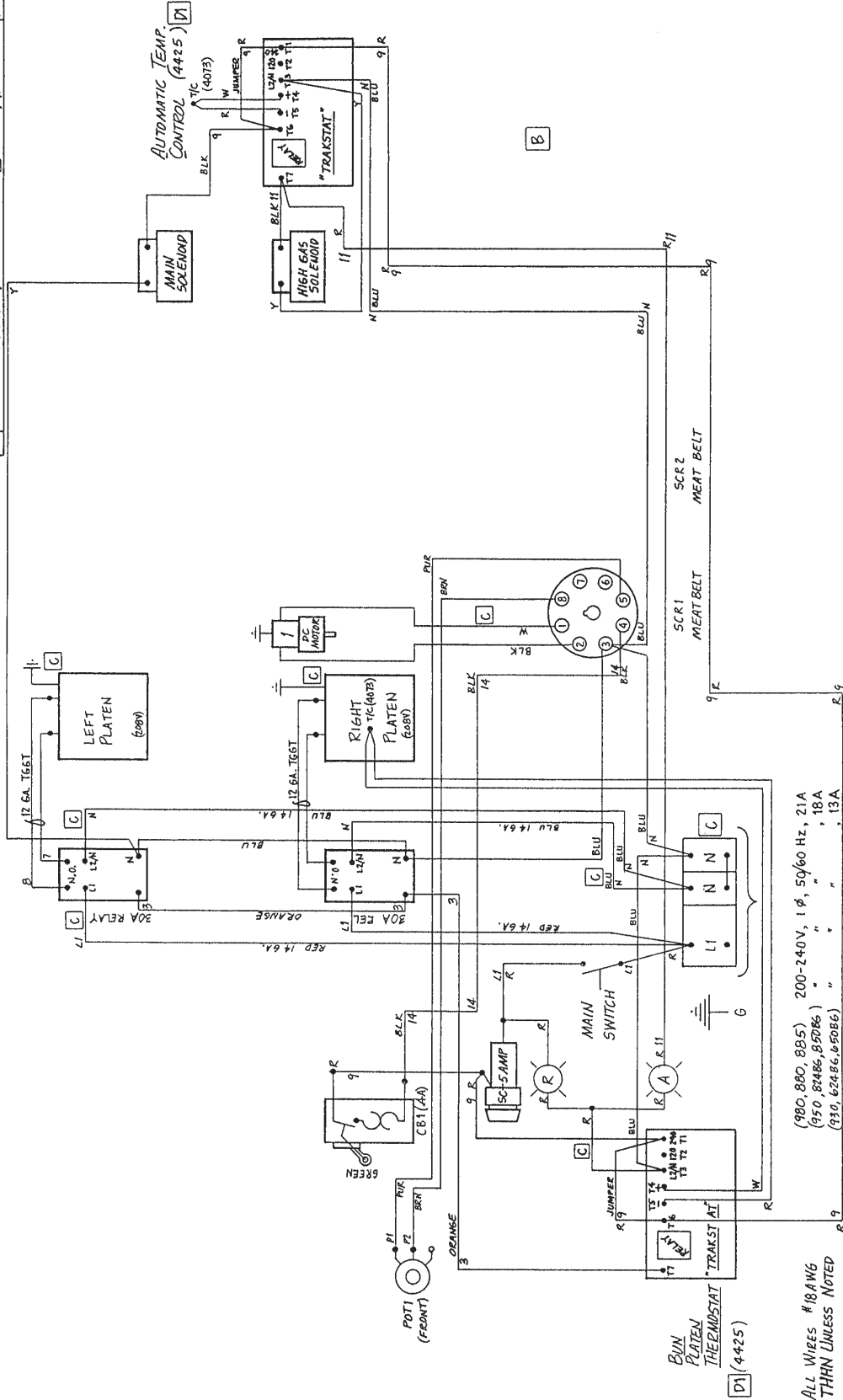



Nieco Corporation • 15 Guittard Rd. • Burlingame, CA 94010 • (650) 697-7335 • Fax (650) 697-3014
Reorder # 9999-99113 2/00 e-mail: nieco@nieco.com Printed in the USA MP