

JAOP3

TABLE OF CONTENTS

<u>SECTION « A » DESCRIPTION</u>	<u>PAGE</u>
Introduction	A1
Construction	A2
Shipping	A2
Installation warnings	A3
Distances to respect	A4
Installation	A5
Operation / instruction for oven and proofer	A6
Operation for proofer	A8
Trouble shooting	A9
Oven maintenance and cleaning	A11
For more information, please call our office:	A12
Optional auto steam injection	A13
Optional watlow control operation	A14
 <u>SECTION « B » DIMENSIONS</u>	
Dimensions	B1
 <u>SECTION « E » COMPONENT PARTS</u>	
Component parts	E1
 <u>SECTION « F » CONTROL PANELS</u>	
120V/208V/1PH & 120V/240 V/1PH	F1
120V/208V/3PH & 120V/240 V/3PH	F3
208V/1PH, 220V/1PH & 240V/1PH	F5
208V/3PH & 240V/3PH	F7
220V/1PH/50 Hz	F9
220V/380V/3PH/50 Hz	F11
120V/208V/1PH & 120V/240V/1PH (WATLOW)	F13
120V/208V/3PH & 120V/240V/3PH (WATLOW)	F15
 <u>SECTION « G » ELECTRIC SCHEMATICS</u>	
120V/208V/1PH & 120V/240V/1PH	G1
120V/208V/1PH & 120V/240V/1PH (DELAY)	G2
120V/208V/3PH & 120V/240V/3PH	G3
120V/208V/3PH & 120V/240V/3PH (DELAY)	G4
208V/1PH, 220V/1PH & 240V/1PH	G5
208V/1PH, 220V/1PH & 240V/1PH (DELAY)	G6
208V/3PH & 240V/3PH	G7

208V/3PH & 240V/3PH (DELAY)	G8
220V/1PH/50 Hz	G9
220V/380V/3PH/50 Hz	G10
120V/208V/1PH & 120V/240V/1PH (WATLOW)	G11
120V/208V/3PH & 120V/240V/3PH (WATLOW)	G12
Warranty	

INTRODUCTION

The manufacturer suggests to read this manual carefully.

This Jet Air oven is manufactured with first quality material by experienced technicians. Proper installation and maintenance will guarantee a reliable service for years to come.

A nameplate fixed to the front or right side of the oven specifies the model number, serial number, voltage and amperage.

Drawings, electrical diagram and replacement parts numbers are included in this manual. The electrical diagram is affixed in the control panel at the back of the oven.

ATTENTION

DOYON is not responsible for damages to the property or the equipment caused by personnel who is not certified by known organisations. The customer is responsible for finding qualified technicians in electricity and plumbing for the installation of the oven.

CONSTRUCTION

You just bought the most advanced oven in the world, "DOYON" technology at its best. This oven is manufactured using the highest quality components and material.

The oven gives a perfect uniform baking with its unique Jet Air convection system. The DOYON oven is designed with parts that are easy to find.

SHIPPING

For your safety, this equipment has been verified by qualified technicians and carefully crated before shipment. The freight company assumes full responsibility concerning the delivery in good condition of the equipment in accepting to transport it.

IMPORTANT

RECEPTION OF THE MERCHANDISE

Take care to verify that the received equipment is not damaged before signing the delivery receipt. If a damage or a lost part is noticed, write it clearly on the receipt. If it is noticed after the carrier has left, contact immediately the freight company in order that they do their inspection.

We do not assume the responsibility for damages or losses that may occur during transportation.

INSTALLATION WARNINGS

POWER FAILURE WARNING

WHEN YOU HAVE A POWER FAILURE, SHUT OFF THE OVEN POWER SWITCH TO PROTECT THE ELECTRONIC COMPONENTS WHEN THE POWER COMES BACK.

FOR YOUR SAFETY

DO NOT STORE OR USE GASOLINE OR OTHER FLAMMABLE VAPORS AND LIQUIDS IN THE VICINITY OF THIS OR ANY APPLIANCE.

INSTALLATION AND SERVICE

WARNING

IMPROPER INSTALLATION, ADJUSTMENT, ALTERATION, SERVICE OR MAINTENANCE CAN CAUSE PROPERTY DAMAGE, INJURY OR DEATH. READ THE INSTALLATION, OPERATING AND MAINTENANCE INSTRUCTIONS THOROUGHLY BEFORE INSTALLING OR SERVICING THIS EQUIPMENT.

Installation and service must be done by specialised technicians. Contact a certified electrician and plumber for set up.

The oven must be connected to the utility and electrically grounded in conformity to the effective local regulations. If these are not established, the oven must be connected according to the Canadian Electrical Code (CSA-C22.1-XX) or National Electrical Code (NFPA 70-XX). Refer to last edition year for XX. Installation must also **allow proper access for service** (24 inches each side and back).

The ovens must be installed with a proper ventilation according with the local building code.

DISTANCES TO RESPECT

- A) Back and sides of the oven: 1 inch.
- B) Top of the oven: a clearance of 12 inches to the ceiling must exist to permit adequate venting.
- C) Floor: 4 inches minimum.
- D) Sides of the oven: do not install other than easily removable equipment for service and maintenance (not closer than 1 inch).
- E) It is recommended to have a certain length of water pipe, electric cable between oven and wall to help gain access for service.

INSTALLATION

IN GENERAL

Take off the packaging material with care. Take off all the material used for packing and accessories.

1. To the electrician

Electrical supply installation must be in accordance with the electrical rating on the nameplate.

WARNING

The electrician must make sure that the supply cable does not come in contact with the oven top which becomes hot.

2. To the plumber

This equipment is to be installed to comply with the applicable federal, state or local plumbing codes.

Connect the steam system (1/4 NPT) to the cold water distribution network.

We highly recommend to use a water filter to eliminate minerals in the water. We suggest you to use CUNO # CFS6135 (Doyon part number PLF240).

WARNING

Do not adjust the needle valves, it has been done at the factory.

OPERATION OF THE OVEN

1. Turn the switch to the " ON " position.
 - The light inside the oven must light up.
2. Adjust the thermostat at the desired setting (see THERMOSTAT INSTRUCTIONS below).

N.B. The red light must be "ON" (If not, press the breaker on the front).

3. Heat the unit until you reach the baking temperature.

When the desired temperature is reached, the red light goes out and turns green.

If the light is still "ON" and the oven does not produce heat, call for service.

4. Load the oven as fast as possible to avoid letting out too much heat.

5. Set the timer to the desired value and start it. (See "TIMER" adjustment on next page.)

NOTE: The timer does not shut the oven off at the end of its cycle. It simply activates the buzzer.

6. **Wait until the product is ready. Do not open the doors until the product is done.**

VERY IMPORTANT

This oven has an overheat warning alarm to protect the electrical components against overheating. If the red pilot light (OVERHEAT WARNING) is lit and you hear a buzzer, see trouble shooting.

THERMOSTAT INSTRUCTIONS

To obtain a very good thermal stability, we use a digital temperature controller with thermocouple. The Omron E5CS thermostat controls the heat of every element at the SP (set point).

The temperature of the oven is always shown on the display of the thermostat and an arrow indicates if the temperature is over or below the SP. When the green light is lit, it indicates that the temperature is at the $SP \pm 1 \%$.

To adjust the SP (set point) value, you just have to press the key on the left and use the up and down keys to set the temperature. Press the left key to return to run mode.

INSTRUCTIONS FOR OVEN

BAKING

350°F (Croissants, Sweet doughs, Small rolls)
375°F (Baguette bread, round loaf, 10 oz. bread and more)
375°F (If the oven is filled to its capacity)

Place products in the oven only when the pilot light has gone out.

OPENING AND CLOSING OF THE DOORS

To open the doors: Open one of the doors up to 2" and wait 2 seconds to let the fan reduce its spinning before opening completely.

To close the doors: Close the first door completely and the second door down to 2" and wait 2 seconds before closing completely and then hold the door closed for 2 seconds.

P.S. Open the doors as little as possible. This will affect the baking.

COOKING TIMER H5CL

Set the baking time required with the small push button on the timer. The green display is the setting time and the red display is the countdown time (Ex: 25 minutes = set 2500 on green display).

After setting: Push the **START/STOP** button then, when the time expires, the buzzer will ring. Push the **START/STOP** button again to stop the buzzer.

If you want to restart the time in the middle of the countdown, press on the yellow **RST** button on the timer.

P.S. The timer is simply a reminder for the approximate duration of the baking time.

STEAM TIMER H3DE

VERY IMPORTANT

Steam injection will only work when the ventilator of the oven is working.

To inject steam in the oven, press and release the **STEAM TIMER** button. The light comes on inside the steam button during the steam injection. Steam injection has been factory preset. To have more steam, press steam button a second time, after the light is off.

P.S. Do not inject steam more than once each time you bake. Wait at least 10 minutes before re-timing the steam injection system.

OPERATION OF THE PROOFER

1. Switch "ON".
2. Set the thermostat control at 100° F.
3. Set the humidity control at approximately : 3 for JAOP-3 & JAOP-6
4 or 5 for JAOP-10
5 for JAOP-14
4. If there is too much fog and water drips from the glass doors, adjust humidity control to a lower number.
5. When the temperature is stabilised, put the products in the proofer.
(Leave them inside until they are ready to bake.)
6. **IMPORTANT** : When proofing cycle is completed, turn the humidity switch to "OFF" and let the motor blower and air heat element run for 10-15 minutes to let dry the proofer. Then, turn the main switch off, and leave the door ajar to prevent moulding.

When the proofer is not in operation, open the doors to let out the humidity and to prevent mould.

P.S. The doors should not be opened unnecessarily to conserve the heat and humidity in the proofer.

Every day cleaning of the water pan under the proofer's doors should be exercised.

TROUBLE SHOOTING
BEFORE CALLING FOR SERVICE
ANSWERS TO MOST FREQUENT QUESTIONS

Always cut off the main power before replacing any parts. Take care of water and electric wire supply system when pulling the oven.

Control parts on the front and proofer control: Remove the side panels of the oven and the proofer by screwing out the screws.

Motor system on the back of oven: Pull the oven and screw out the panels.

Questions	Solutions
The oven does not turn on.	<p>Check the breakers on the front panel. Check the breakers of the building. Check if the doors are tightly closed. Check the motor fuses and the overload relays located in the electrical control panel.</p>
Uneven baking.	<p>Make sure that the grills do not obstruct the air flow. Do not use foil on the grills.</p> <p>Verify the temperature of the oven by using an oven thermometer and make sure that it is even with the thermostat setting.</p> <p>If the oven is baking too much on the sides, it is possible that the fan is not cycling properly. Verify if the motor turns 2.5 minutes in a direction, stops 30 seconds and starts for 2.5 minutes in the opposite direction.</p>
The oven does not produce heat.	<p>1- If the oven blowers are on</p> <ul style="list-style-type: none"> • Make sure: the thermostat is adjusted to a temperature high enough to turn on the pilot light. <p>If the oven blowers are not on, check the overload relays located in the control compartment. If anyone of these is disengaged, call for a qualified technician.</p>
The steam works in the oven but the light inside the steam button does not lite.	<p>Replace the inside button bulb light.</p>

<p>If steam device of the oven does not work properly.</p>	<p>The oven must have been heating for at least half an hour before you use the steam system. If not, water will appear at the bottom of the oven.</p> <p>Check if the water supply valve (of the building) is open.</p> <p>Check if the water needle valve (of the oven) is open one eighth of a turn. Just close it and open it one eighth of a turn maximum.</p> <p>Check the solenoid valve.</p> <p>Check the preset steam timer in the back control box.</p> <p>Be sure to inject steam while the fan is running.</p> <p>The steam button light should lite during the steam injection.</p>
<p>If the OVERHEAT WARNING light is on, and you hear the warning buzzer.</p>	<p>Check if the cooling fan airflow is not obstructed.</p> <p>Check the cooling fan if it is running. If not, call a qualified technician to replace it.</p> <p>(Electrical components may be damaged if it is not repaired immediately.)</p>
<p>OPTIONAL Manual fill water pan. The warning red light in the front control panel stays on when the water pan is full.</p>	<p>You have no more water in the principal water pan.</p> <p>Check if the water line is not in air lock condition. Disconnect the water line at the inlet of the green solenoid valve and clean the strainer filter.</p> <p>Also clean the principal water pan and the float switch.</p>
<p>If there is no light in the proofer.</p>	<ol style="list-style-type: none"> 1. Verify every breaker in front of the proofer. 2. Verify the main proofer switch and the main proofer contactor.
<p>If there is no heat in the proofer.</p>	<ol style="list-style-type: none"> 1. Verify every breaker in front of the proofer. 2. Verify whether the pilot light will function by raising the thermostat to a higher setting. If yes, verify element. If not, verify pilot light, thermostat or contactors.
<p>If there is no humidity in the proofer.</p>	<p>Verify whether the pilot light works when you increase the humidity to the position high. If yes, verify if water comes in the reservoir and check the water level switch box and the float switch. Verify if limestone obstructs the waterflow. If the float switch is working fine, verify the contactor P1 and the immersion element. If the pilot light does not lite, verify the pilot light and the infinite switch.</p>

OVEN MAINTENANCE AND CLEANING

MAINTENANCE OF THE OVEN

- It is recommended to use a water filter and to clean or replace it regularly to avoid accumulation of minerals inside the unit.
- Once a year or as needed, clean the reservoir of the proofer (see parts description for localization).

Step by step	Recommendations
<p>Clean the inside of the oven and the proofer with water and soap.</p> <p>Take out the grills (the grills of the oven could be cleaned with "Easy-Off").</p>	<p>We recommend and sell: Dirt Buster III : Action foam cleaner CHEMCO Part number : NEB201</p>
<p>After cleaning the inside of the oven, apply a silicone base oven protector. It avoids food from sticking to the metal.</p>	<p>We recommend and sell: 316 Silicone base protector and lubricant for oven Dow Corning Part number : EXS400</p>
<p>Clean the oven windows with products like Brasso or equivalents. They are copper cleaners but good for this use.</p>	<p>We recommend and sell: Wright's: Cream copper cleaner J.A. Wright & Co. Part number : EXC300</p>
<p>Clean the oven exterior with a stainless steel cleaner.</p>	<p>We recommend and sell: Stainless steel cleaner SANY or CURTIS (comestible) Part number : NES201</p>

**FOR MORE INFORMATION,
PLEASE CONTACT OUR OFFICE:**

DOYON EQUIPMENT INC.
1255, rue Principale
Linière, Qc, Canada G0M 1J0

Tel. : 1 (418) 685-3431
Canada : 1 (800) 463-1636
U.S. : 1 (800) 463-4273
FAX : 1 (418) 685-3948

Internet: <http://www.doyon.qc.ca>
E-Mail : doyon@doyon.qc.ca

AUTOMATIC STEAM OPTION

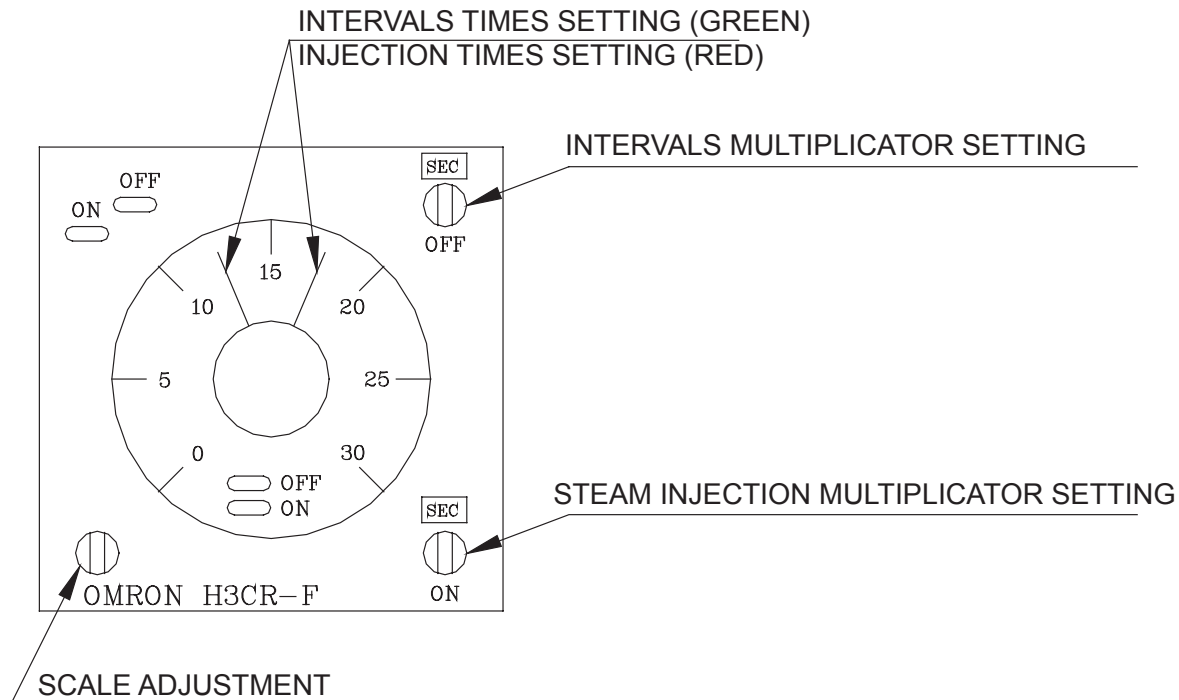

By pushing the GREEN button, the button will light up and the automatic system injection will start. The injection will be done as per the pre-adjustment time on the automatic steam timer. The standard steam timer (white light) will light up during the steam injection. Push the RED button to stop the automatic steam injection and then, the GREEN button will turn off.

Timer adjustments

EXAMPLE : For 5 seconds of steam injection every 10 minutes : Set the interval multiplier screw (**OFF**) at MIN and the GREEN needle at 10. Set the injection multiplier screw (**ON**) at SEC and the RED needle at 5.

EXAMPLE : For 2 seconds of steam injection every 25 seconds : Set the interval multiplier screw (**OFF**) at SEC and the GREEN needle at 25. Set the injection multiplier screw (**ON**) at SEC and the RED needle at 2.

WATLOW CONTROL OPERATION

1. Turn the switch to the " ON " position. (See next paragraph for the factory-preset program on your watlow control.)
 - The light inside the oven must light up.
2. Adjust the WATLOW control at the desired setting (see watlow programming procedure next page).

Digital display must light up, if not verify the breaker on the front panel.

3. Let the oven heat until the set temperature is reached, the LOAD1 red light on the watlow control will go off when the temperature is stabilized.
4. Load the oven as fast as possible to avoid letting out too much heat.
5. Wait until the product is ready before opening doors.

FACTORY PRESET BAKING PROGRAM

MENU # 1 PREHEAT 400°F.

MENU # 2 375°F STEAM 15 SEC., COOKING TIME 22 MINUTES WITH BUZZER.

MENU # 3 350°F STEAM 15 SEC., COOKING TIME 25 MINUTES WITH BUZZER.

MENU # 4 325°F NO STEAM, COOKING TIME 25 MINUTES WITH BUZZER.

325°F (Muffins)

350°F (Croissants, Sweet Doughs, Small rolls)

375°F (Baguette bread, round loaf, 10 oz. bread and more)

375°F (If the oven is filled to its capacity)

OPENING AND CLOSING OF THE DOORS

To open the doors: Open one of the doors up to 2" and wait 2 seconds to let the fan reduce its spinning before opening completely.

To close the doors: Close the first door completely and the second door down to 2" and wait 2 seconds before closing completely and then hold the door closed for 2 seconds.

P.S. Open the doors as little as possible. This will affect the baking.

POWER FAILURE

When the power comes back the oven will start automatically on the menu #1. Then it is recommended to turn off the oven to avoid that it starts without supervision.

WATLOW PROGRAMMING

The Watlow temperature control can record 12 different menus. It must be programmed before use. It will save its programs in case of power failure.

Each menu includes 3 "STEPS" and each step includes :

Symbol

- | | | |
|---------------|----|---|
| • temperature | SP | |
| • time | t | |
| • "EVENT" | E | (steam 0001, auto steam 0100, buzzer 0010 or no event 0000) |

To access the programming mode :

- Press both arrows simultaneously for 5 seconds. Both lights light up to show that the programming mode is working.
- Unlock the read only mode (if necessary), press 12 and "CLOCK", LOC appears. Use the arrows to get 0 and press "CLOCK" again. (To put back on read only mode, you have to have 1 before pressing on "CLOCK".)

EXAMPLE 1 (preheat program)

- For menu #1, we will program it so that we have a preheat time of 20 minutes at 400°F followed by a 15 seconds buzzer.

Step #1

- Press both arrows simultaneously for 5 seconds. Both lights light up to show that the programming mode is working.
- Select the program number (Ex : #1)

	<u>Suggested values</u>
SP1 appears.	
Use the arrows to adjust to the desired temperature	(400°F)
Press on the number of the menu to confirm	(ex. # 1)
t1 appears	
Use the arrows to select the desired timing	(20:00)
Press on the number of the menu to confirm	(ex. # 1)

E1 appears
 Use the arrows to select the appropriate code (0010 for the buzzer)
 Press on the number of the menu to confirm (ex. # 1)

Step #2**Suggested values**

SP2 appears.
 Use the arrows to adjust to the desired temperature (400°F)
 Press on the number of the menu to confirm (ex. # 1)

t2 appears
 Use the arrows to select the desired timing (00:15)
 Press on the number of the menu to confirm (ex. # 1)

E2 appears
 Use the arrows to select the appropriate code (0010 for buzzer)
 Press on the number of the menu to confirm (ex. # 1)

Step #3**Suggested values**

SP3 appears.
 Use the arrows to adjust to the desired temperature (400°F)
 Press on the number of the menu to confirm (ex. # 1)

t3 appears
 Use the arrows to select the desired timing (00:01)
 Press on the number of the menu to confirm (ex. # 1)

E3 appears
 Use the arrows to select the desired code (0000 for no event)
 Press on the number of the menu to confirm (ex. # 1)

To get out of the programming mode, press #12 and then press "CLOCK" twice (#12, CLOCK, CLOCK). The screen will show 00:00.

Note: You should always use menu #1 for preheating because the controls starts automatically with this menu.

WARNING

Never use program #1 for a steam cycle because it will start automatically when the oven is turned on.

EXAMPLE 2 (Cooking program with steam cycle)

-For menu #2, we will program it so that we have a steam injection of 20 seconds, a cooking time of 20 minutes at 375°F followed by a 15 seconds buzzer.

To access the programming mode:

- Press both arrows simultaneously for 5 seconds. Both lights light up to show that the programming mode is working.
- Select the menu number (Ex. #2)

Step #1**Suggested values**

SP1 appears.

Use the arrows to adjust to the desired temperature

(375°F)

Press on the number of the menu to confirm

(ex. # 2)

t1 appears

Use the arrows to select the desired timing

(00:20)

Press on the number of the menu to confirm

(ex. # 2)

E1 appears

Use the arrows to select the appropriate code

(0001 for the steam)

Press on the number of the menu to confirm

(ex. # 2)

Step #2**Suggested values**

SP2 appears.

Use the arrows to adjust to the desired temperature

(375°F)

Press on the number of the menu to confirm

(ex. # 2)

t2 appears

Use the arrows to select the desired timing

(20:00)

Press on the number of the menu to confirm

(ex. # 2)

E2 appears

Use the arrows to select the appropriate code

(0000 for no event)

Press on the number of the menu to confirm

(ex. # 2)

Step #3**Suggested values**

SP3 appears.

Use the arrows to adjust to the desired temperature

(375°F)

Press on the number of the menu to confirm

(ex. # 2)

t3 appears

Use the arrows to select the desired timing

(00:15)

Press on the number of the menu to confirm

(ex. # 2)

E3 appears

Use the arrows to select the desired code

(0010 for the buzzer)

Press on the number of the menu to confirm

(ex. # 2)

To get out of the programming mode, press #12 and then press "CLOCK" twice (#12, CLOCK, CLOCK). The screen will show 00:00.

After fulfillment of this program:

- The oven will continue to heat because there was a temperature included in step 3. If the temperature at that step would have been of 0°F, the oven would have stopped at the end of the program.
- In this example, the inside buzzer will work 15 seconds while the outside buzzer will start and will not stop until another program is selected.
- If you want to end a program already running, press the button corresponding to that menu and then choose a pause menu. If you stop a program that was running without choosing another menu, it will be paused in the conditions in which it was stopped. Ex: If there is an interruption during a steam cycle, it will keep running until you choose another menu. However, there is a 45 seconds limit time for the steam, independent from the Watlow controller.

SECTION
B

DIMENSIONS

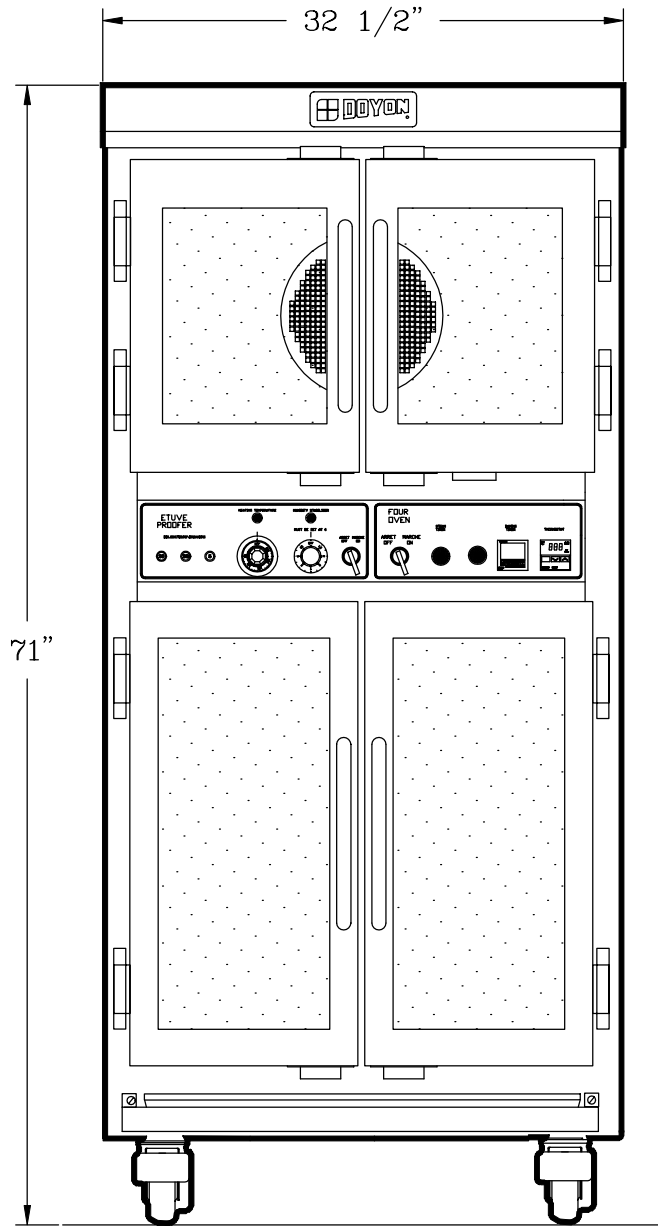

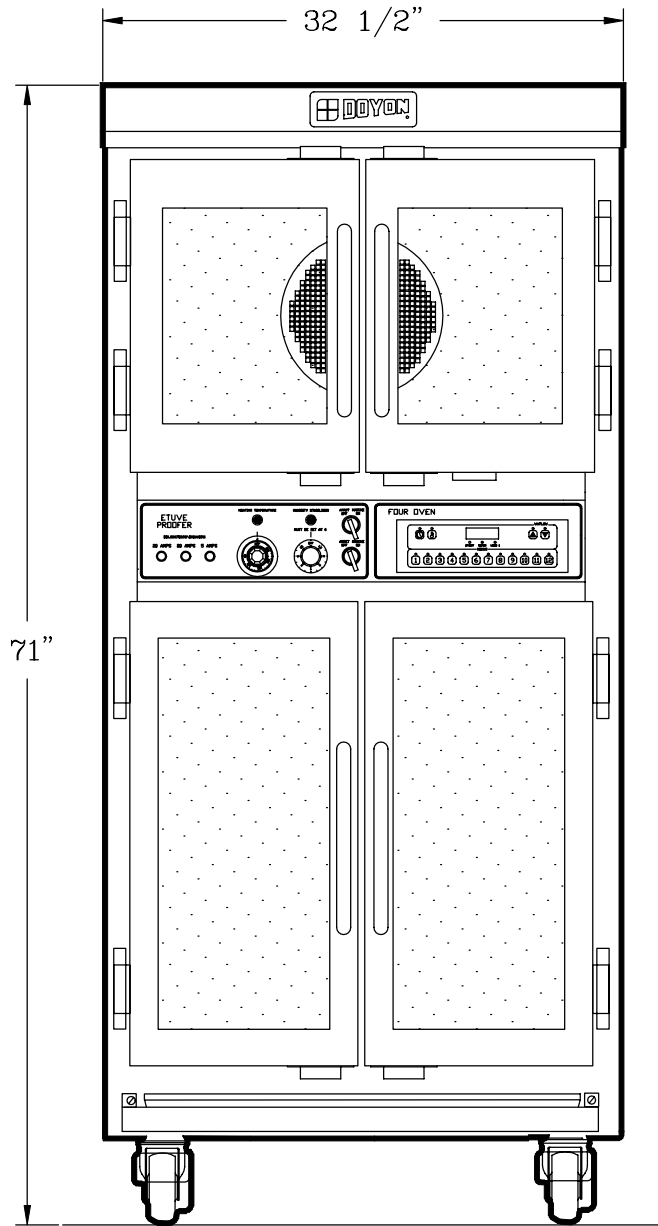

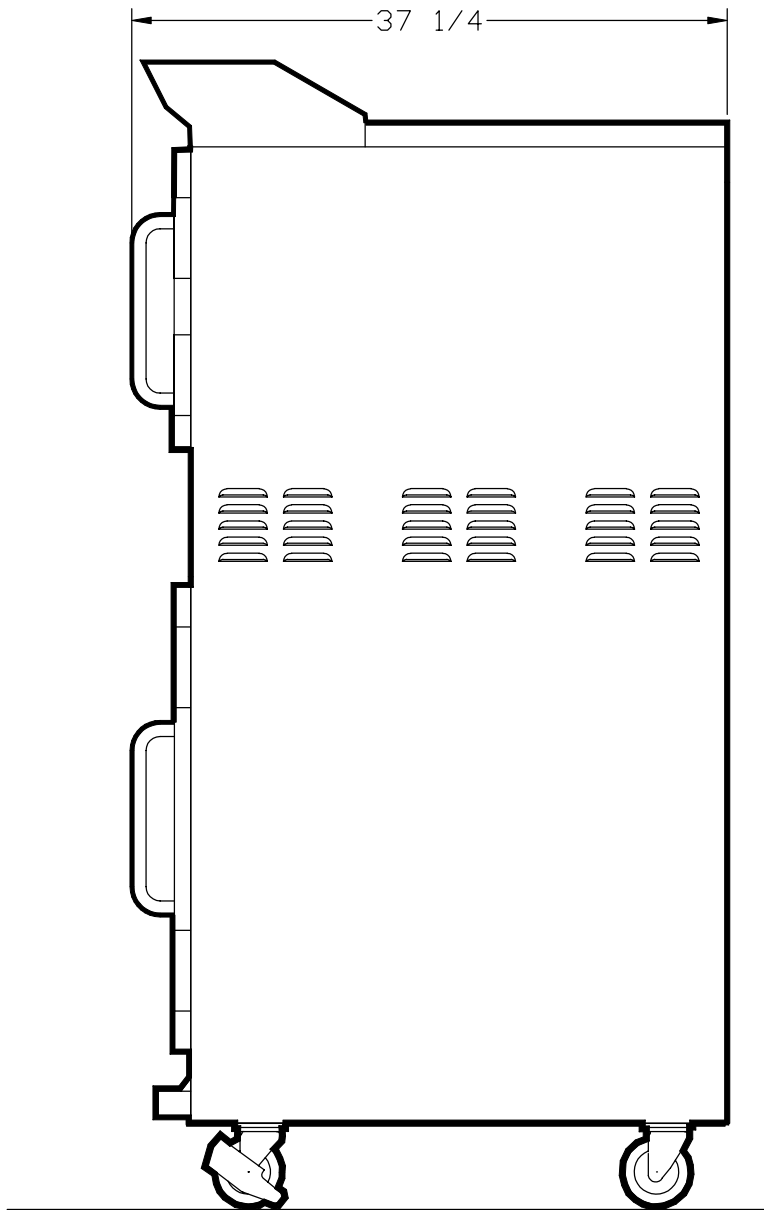

JAP3

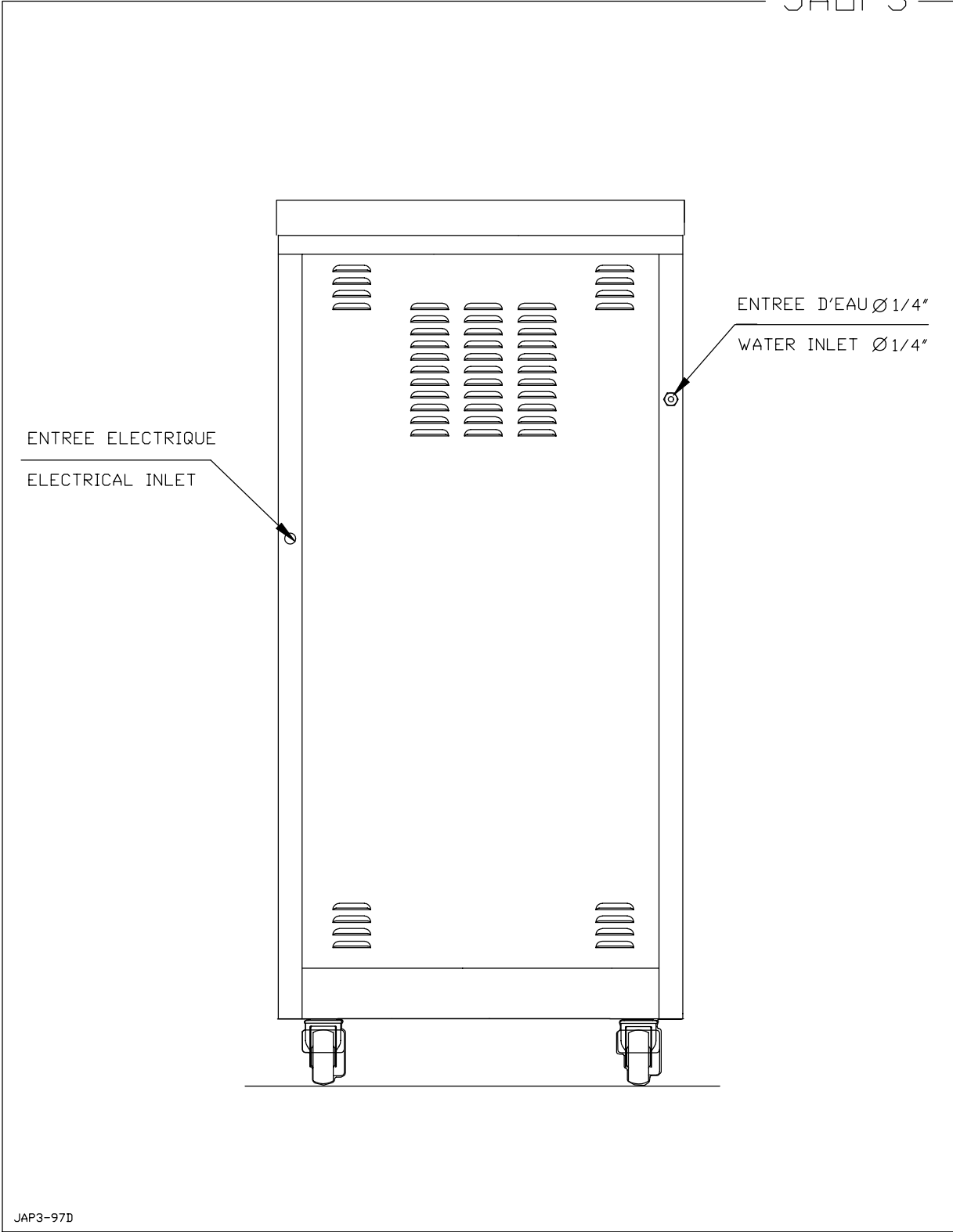

SECTION
E

COMPONENT PARTS

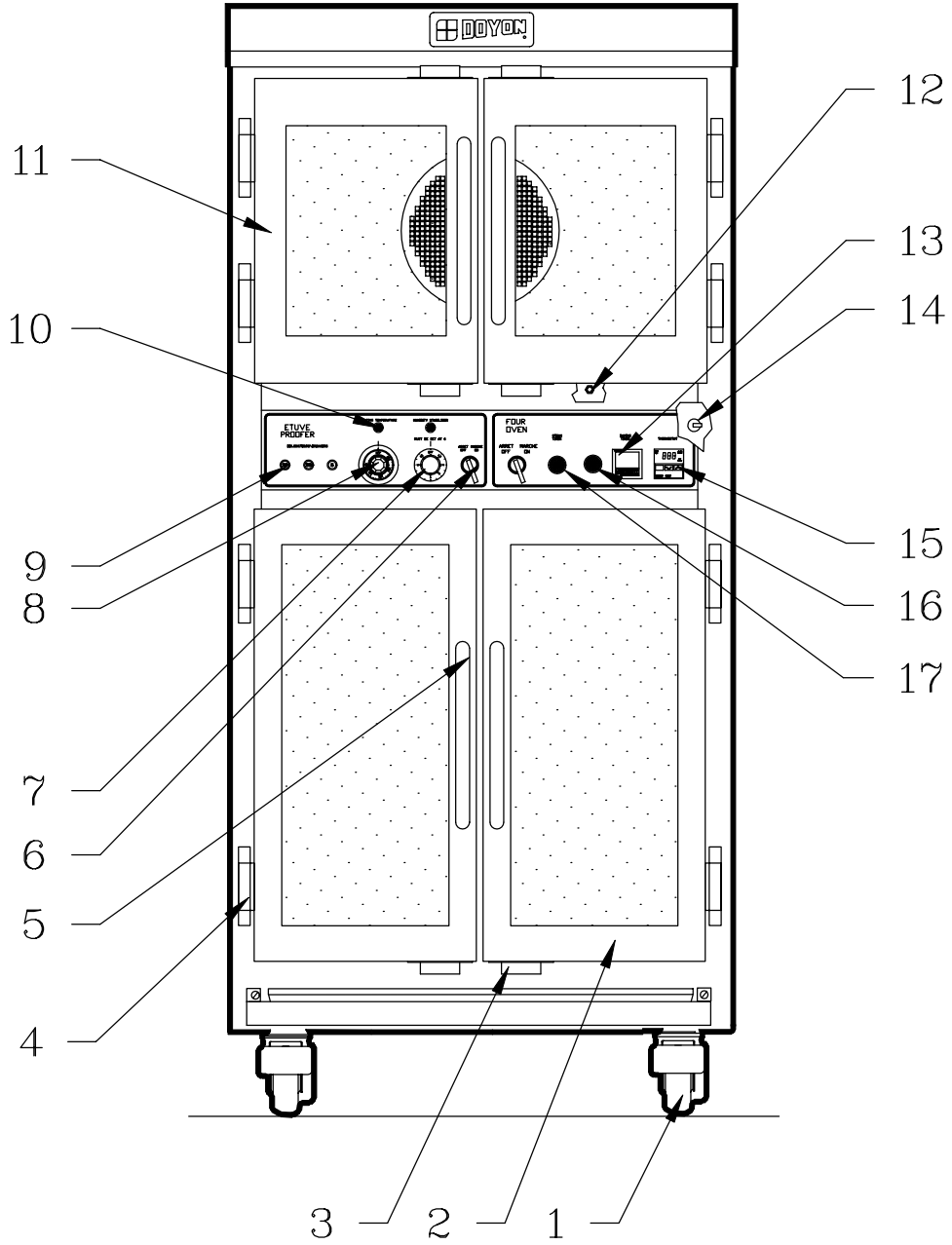

Item	Part Number	Description	Quantity
1	PAR800	SWIVEL CASTER	2
AND	PAR850	SWIVEL CASTER WITH BRAKE	2
2	P1430ED	RIGHT DOOR OF JA-4-SC	1
AND	P1430EG	LEFT DOOR OF JA-4-SC	1
AND	QUE500	DOOR GASKET(10')	1
3	QUA200	DOOR MAGNET	6
4	QUP320	DOOR HINGE	8
5	QUP465	DOOR HANDLE STAINLESS TUBING	4
6	ELI550	MAIN SWITCH (SELECTOR)	2
AND	ELI555	CONTACT BLOCK 1NO	2
7	ELI220	INFINITY SWITCH 120V (HUMIDITY CONT.)	1
OR	ELI230	INFINITY SWITCH 240V (HUMIDITY CONT.)(240 VOLTS)	1
AND	ELI240	INFINITY SWITCH KNOB	1
8	ELT627	THERMOSTAT 110F	1
AND	ELT628	THERMOSTAT KNOB 110F	1
AND	ELT620	THERMOSTAT BEZEL	1
9	ELB096	5A BREAKER	1
AND	ELB097	20A BREAKER	2
AND	ELB098	2A BREAKER(NO 110 VOLTS)	2
10	ELL650	RED PILOT LIGHT	2
11	P1419FD	RIGHT OVEN DOOR 19 3/8 X 14 9/16	1
AND	P1419FG	LEFT OVEN DOOR 19 3/8 X 14 9/16	1
AND	QUE500	DOOR GASKET(9')	1
12	ELM570	DOOR SWITCH	1
13	ELM616	ELECTRONIC TIMER OMRON H5CX-L8	1
AND	ELM629	ELECTRONIC TIMER 8 PIN SOCKET	1
AND	ELM726	PANEL MOUNTING	1
14	ELS950	BUZZER 120V	1
15	ELT515	ELECTRONIC THERMOSTAT	1
AND	ELT522	THERMOCOUPLE J TYPE	1
16	ELP994	PUSH-BUTTON (BLACK)	1
AND	ELI554	MECHANICAL HOLD (ON-OFF) CONTACT	1
AND	ELI555	CONTACT BLOCK 1NO	1
17	ELL775	HIGHLITED PUSH BUTTON SOCKET WHITE	1
AND	ELL756	PUSH BUTTON SOCKET (N.O.)	1
AND	ELL645	MINIATURE LAMP 3 WATTS 130 VOLTS	1

Model : JAOP3V

View : FRONT (Steam)

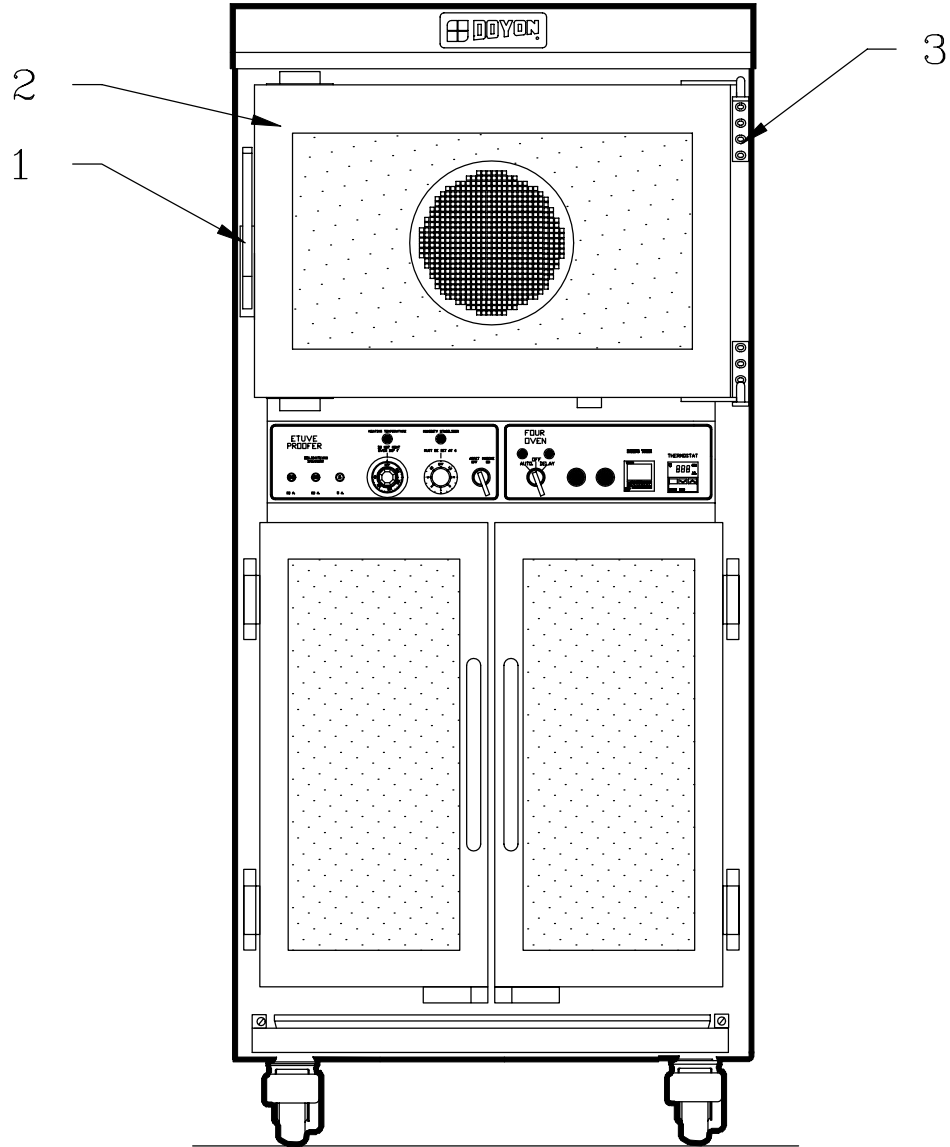

Item	Part Number	Description	Quantity
1	QUP520	MAGNETIC HANDLE	1
2	P1929F-S	SUBWAY DOOR OVEN 19 1/2 x 29 1/2	1
2	P1929F-S	JAOP-3 SUBWAY DOOR OVEN	1
AND	QUE500	DOOR GASKET(9')	1
3	STP001	TOP MALE HINGE	1
AND	STP002	TOP FEMALE HINGE	1
AND	STP003	BOTTOM MALE HINGE	1
AND	STP004	BOTTOM FEMALE HINGE	1

Model : JAOP3E (SUBWAY)

View : FRONT

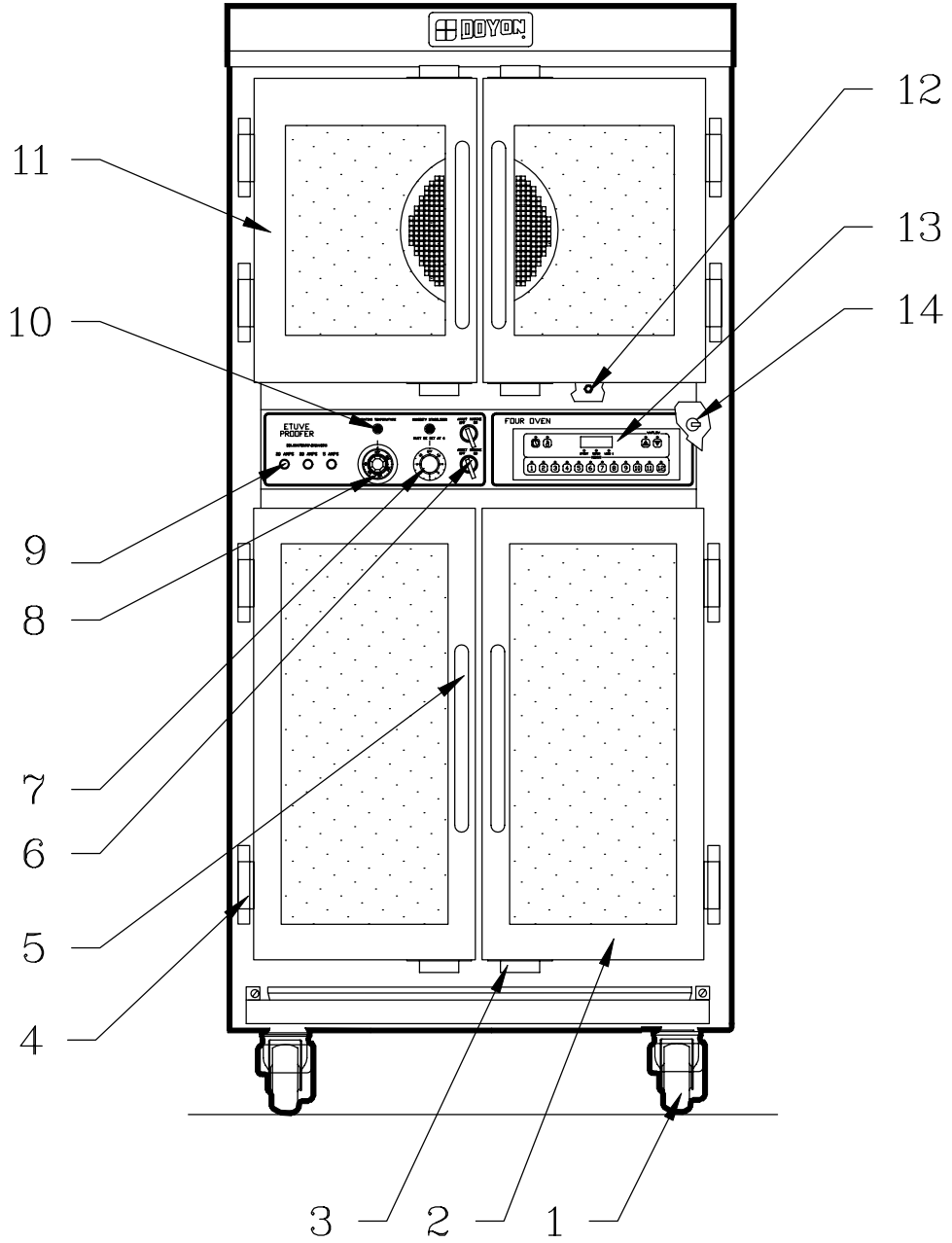

Item	Part Number	Description	Quantity
1	PAR800	SWIVEL CASTER	2
AND	PAR850	SWIVEL CASTER WITH BRAKE	2
2	P1430EG	LEFT PROOFER DOOR 14 1/2" X 30 3/4"	1
2	P1430EG	LEFT DOOR OF JA-4-SC	1
AND	P1430ED	RIGHT PROOFER DOOR 14 1/2" X 30 3/4"	1
AND	P1430ED	RIGHT DOOR OF JA-4-SC	1
AND	QUE500	DOOR GASKET(10')	1
3	QUA200	DOOR MAGNET	6
4	QUP320	DOOR HINGE	8
5	QUP465	DOOR HANDLE STAINLESS TUBING	4
6	ELI550	MAIN SWITCH (SELECTOR)	2
AND	ELI555	CONTACT BLOCK 1NO	2
7	ELI220	INFINITY SWITCH 120V (HUMIDITY CONT.)	1
AND	ELI240	INFINITY SWITCH KNOB	1
8	ELT627	THERMOSTAT 110F	1
AND	ELT628	THERMOSTAT KNOB 110F	1
AND	ELT620	THERMOSTAT BEZEL	1
9	ELB097	20A BREAKER	2
AND	ELB096	5A BREAKER	1
10	ELL650	PILOT LIGHT	2
11	P1419FG	LEFT OVEN DOOR 19 3/8 X 14 9/16	1
11	P1419FG	LEFT OVEN DOOR 19 3/8 X 14 9/16	1
AND	P1419FD	RIGHT OVEN DOOR 19 3/8 X 14 9/16	1
AND	P1419FD	RIGHT OVEN DOOR 19 3/8 X 14 9/16	1
AND	QUE500	DOOR GASKET(9')	1
12	ELM570	DOOR SWITCH	1
13	ELT536	HORIZONTAL WATLOW CONTROL	1
14	ELS950	BUZZER 120V	1

Model : JAOP3E WATLOW

View : FRONT (Steam)

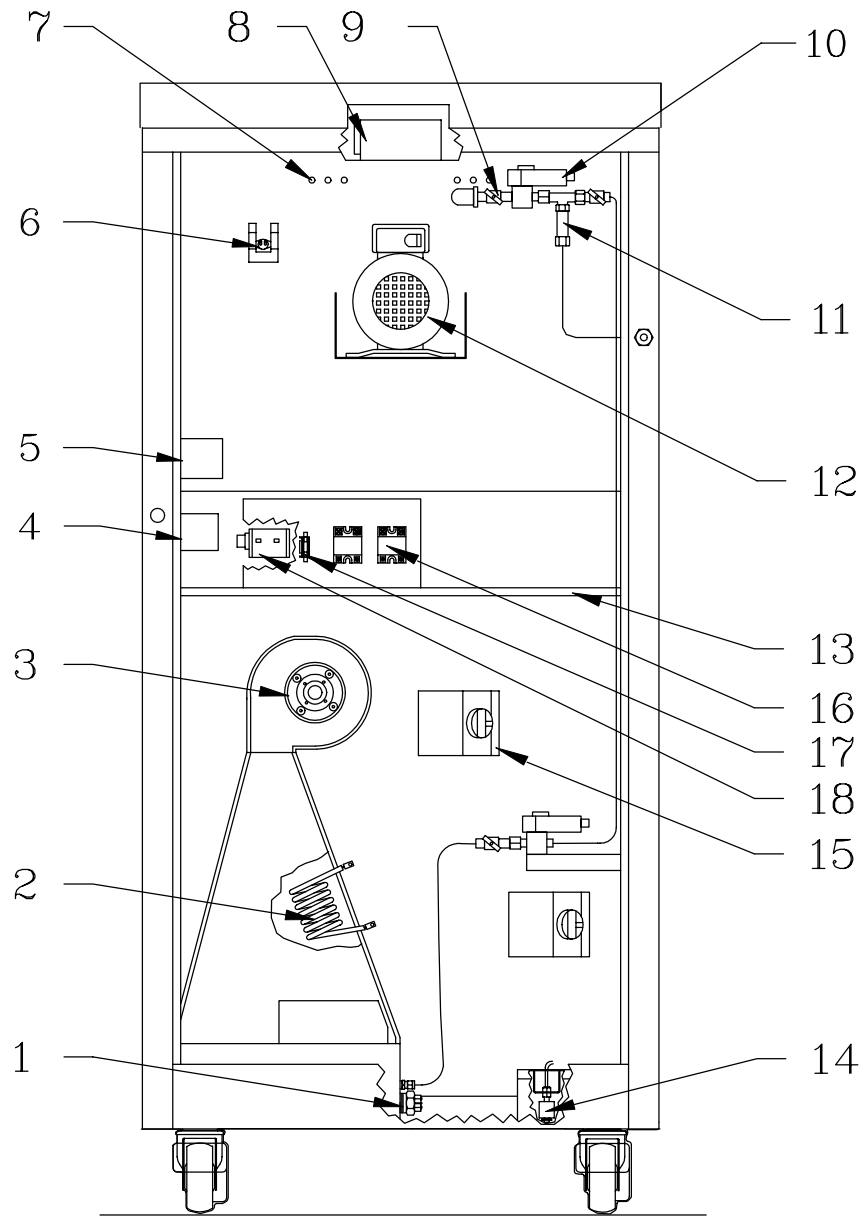

Item	Part Number	Description	Quantity
1	ELE165	IMMERSION ELEMENT 120V 1500W	1
2	ELE130	COIL ELEMENT 120V 1500W	1
3	ELM730	PROOFER FAN BLOWER	1
4	ELT712	TRANSFORMER 240/120 50VA(MOD. 220 V ONLY)	1
OR	ELT725	TRANSFORMER 240/120 250VA(MOD. 220 V ONLY)	1
5	ELT715	TRANSFORMER 240>120 100VA(MOD. 220 V ONLY)	1
OR	ELT725	TRANSFORMER 240/120 250VA(MOD. 220 V ONLY)	1
6	ELT506	HIGH LIMIT TEMPERATURE(OPTIONAL)	1
7	ELE120	STRAIGHT ELEMENT 240V 2500W	3
OR	ELE110	STRAIGHT ELEMENT 208V 2500W	3
8	ELD050	INCANDESCENT LIGHT SOCKET	1
AND	ELA350	HALOGEN BULB 100 WATTS 120V	1
9	ELV590	NEEDLE VALVE	2
10	ELS880	SOLENOID VALVE 110/120V 50/60Hz	2
11	PLF100	WATER FILTER	1
12	ELM800M	MOTOR .75HP 1PH 115/208-230V 60Hz/50Hz A.O. SMITH	1
OR	ELM820M	MOTOR 3/4HP 3PH 208/230/460V 60Hz/50Hz A.O. SMITH	1
13		(ELECT PAN. V (P208S-S5 OR P240S-S5))	
14	QUF350	ELECTRIC FLOAT	1
15	ELA275	BULB 60W 130V	2
AND	ELD050	INCANDESCENT LIGHT SOCKET	2
16	ELC800	SOLID STATE RELAY (S.S.R.)(WATLOW OPTIONAL)	1
17	ELF960	LITTLE-FUSE HOLDER 30A 300V(WATLOW OPTIONAL)	1
AND	ELF855	LITTLE-FUSE 1A 250V(WATLOW OPTIONAL)	1
18	GAT100	TRANSFORMER 120/25V 20VA.(WATLOW OPTIONAL)	1

Model : JAOP3E WATLOW

View : BACK

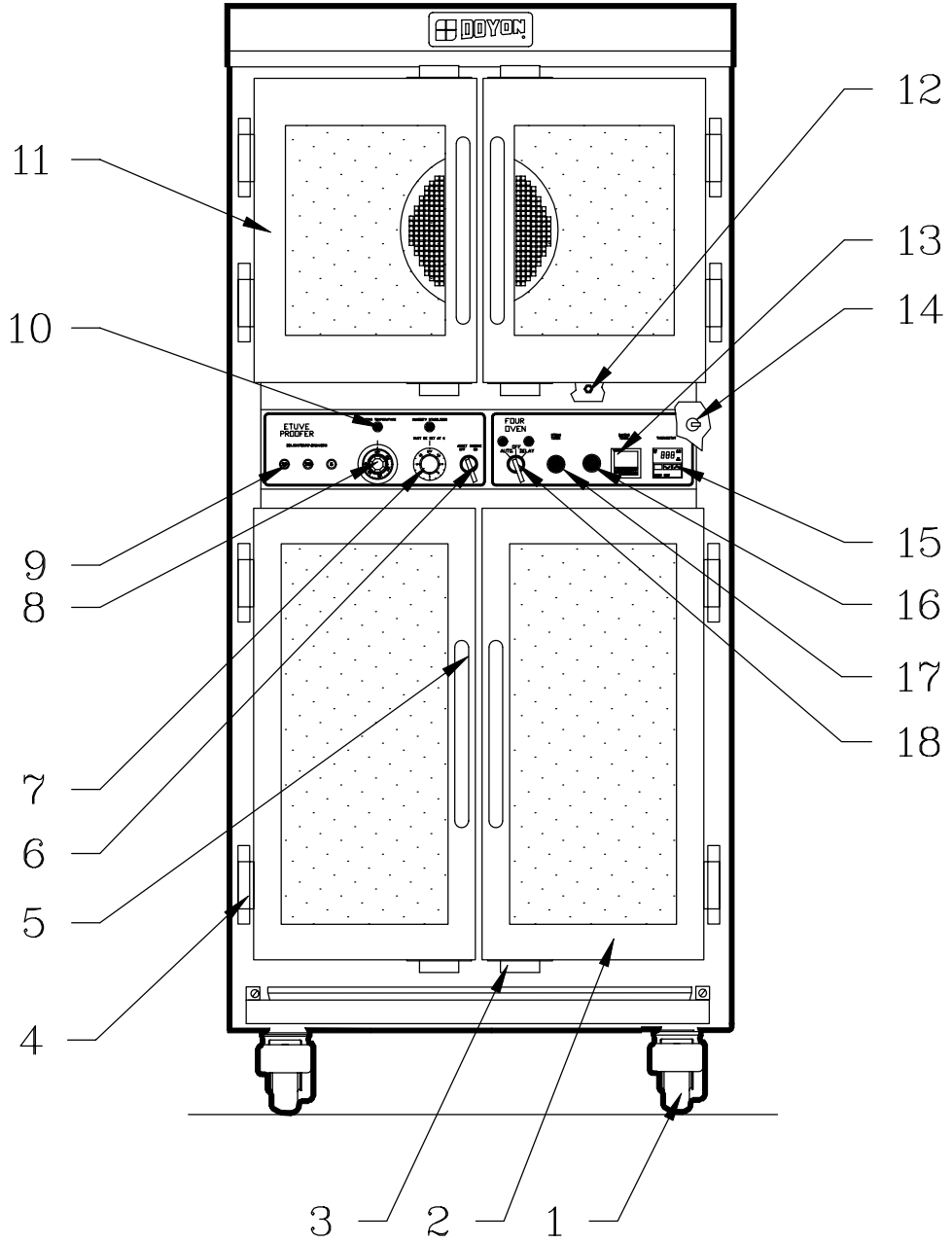

Item	Part Number	Description	Quantity
1	PAR800	SWIVEL CASTER	2
AND	PAR850	SWIVEL CASTER WITH BRAKE	2
2	P1430ED	RIGHT DOOR OF JA-4-SC	1
AND	P1430EG	LEFT DOOR OF JA-4-SC	1
AND	QUE500	DOOR GASKET(10')	1
3	QUA200	DOOR MAGNET	6
4	QUP320	DOOR HINGE	8
5	QUP465	DOOR HANDLE STAINLESS TUBING	4
6	ELI550	MAIN SWITCH (SELECTOR)	1
AND	ELI555	CONTACT BLOCK 1NO	1
7	ELI220	INFINITY SWITCH 120V (HUMIDITY CONT.)	1
OR	ELI230	INFINITY SWITCH 240V (HUMIDITY CONT.)	1
AND	ELI240	INFINITY SWITCH KNOB	1
8	ELT627	THERMOSTAT 110F	1
AND	ELT628	THERMOSTAT KNOB 110F	1
AND	ELT620	THERMOSTAT BEZEL	1
9	ELB096	5A BREAKER	1
AND	ELB097	20A BREAKER	2
AND	ELB098	2A BREAKER(NO 110 VOLTS)	2
10	ELL650	RED PILOT LIGHT	2
OR		(DELAY OPTION)	4
11	P1419FD	RIGHT OVEN DOOR 19 3/8 X 14 9/16	1
AND	P1419FG	LEFT OVEN DOOR 19 3/8 X 14 9/16	1
AND	QUE500	DOOR GASKET(10')	1
12	ELM570	DOOR SWITCH	1
13	ELM616	ELECTRONIC TIMER OMRON H5CX-L8	1
AND	ELM629	ELECTRONIC TIMER 8 PIN SOCKET	1
AND	ELM726	PANEL MOUNTING	1
14	ELS950	BUZZER 120V	1
15	ELT515	ELECTRONIC THERMOSTAT	1
AND	ELT522	THERMOCOUPLE J TYPE	1
16	ELP994	PUSH-BUTTON (BLACK)	1
AND	ELI554	MECHANICAL HOLD (ON-OFF) CONTACT	1
AND	ELI555	CONTACT BLOCK 1NO	1
17	ELL775	HIGHLITED PUSH BUTTON SOCKET WHITE	1
AND	ELL756	PUSH BUTTON SOCKET (N.O.)	1
AND	ELL645	MINIATURE LAMP 3 WATTS 130 VOLTS	1
18	ELI550	MAIN SWITCH (SELECTOR)	1
AND	ELI555	CONTACT BLOCK 1NO	1
OR	ELI551	MAIN SWITCH (SELECTOR 3 WAYS)(DELAY OPTION)	1
AND	ELI570	CONTACT BLOCK 2NO(DELAY OPTION)	2
AND	ELI575	CONTACT BLOCK 1NC(DELAY OPTION)	1

Model : JAOP3DV (Delai Vapeur)

View : FRONT (Delay & Steam)

SECTION
F

CONTROL PANELS

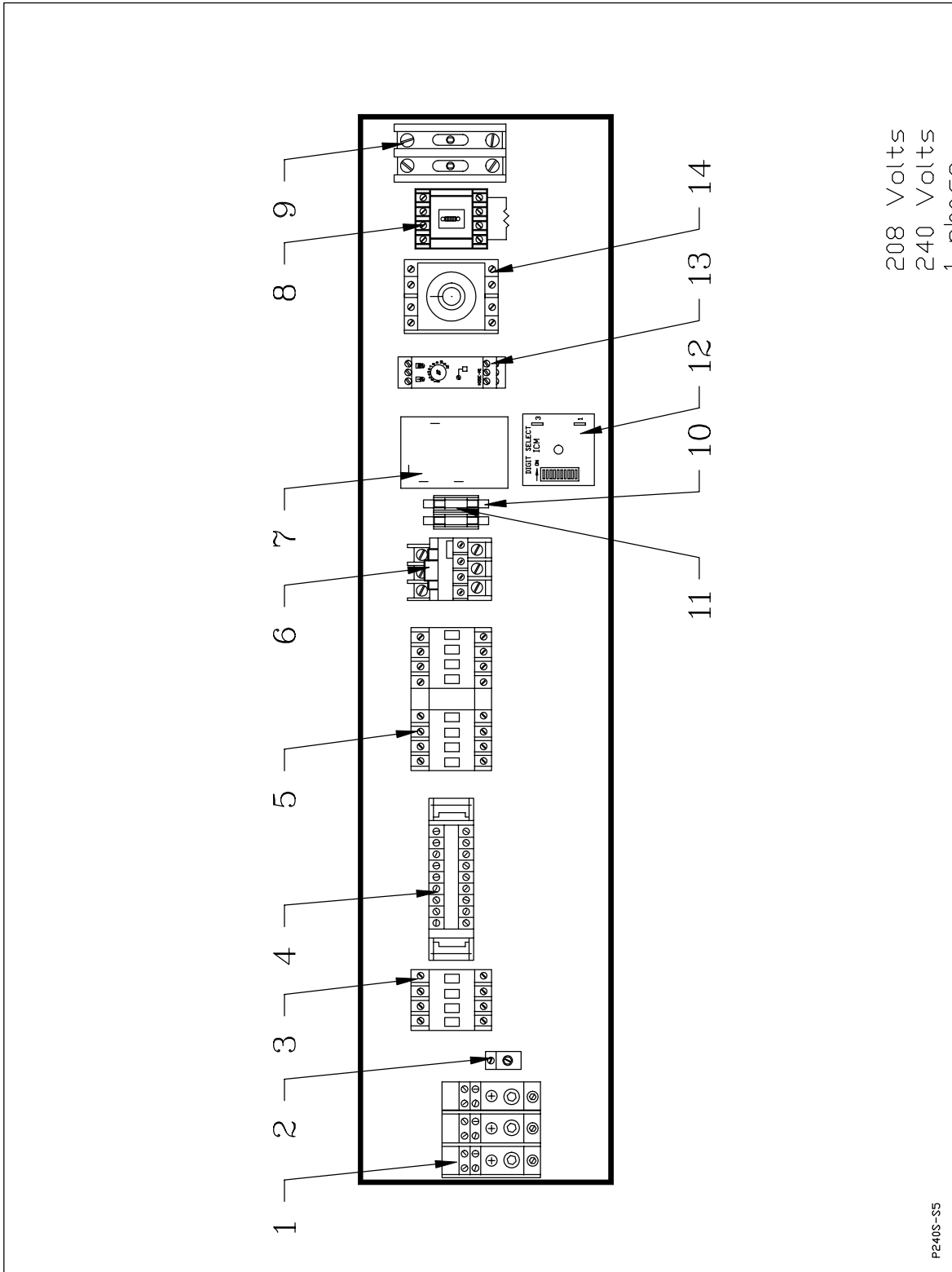

208 Volts
240 Volts
1 phase
Simple - JAOP3DV

Item	Part Number	Description	Quantity
1	ELB072	TERMINAL BLOCK 3P 175A	1
2	ELL050	GROUND LUG	1
3	ELC908	HEATING CONTACTOR	1
	ELC909	HEATING CONTACTOR, COIL (ONLY)	
4	ELB073	TERMINAL BLOCK 30A	12
5	ELC515	MOTOR REVERSING CONTACTOR 2HP	1
	ELC520	CONTACTOR COIL (ONLY)	
6	ELO215	OVERLOAD RELAY SIMPLE PHASE 2 TO 7 AMPS.	1
AND	ELO220	OVERLOAD RELAY BASE	1
7	ELM715	PRESET TIMER 25SEC. OFF - 150SEC. ON	1
8	ELC615	RELAY 10A 2P COIL 110V	1
AND	ELC617	BASE	1
AND	ELM736	LOAD FOR TIMER	1
9	ELC860	CONTACTOR 2P 30A 110V	1
10	ELF960	LITTLE-FUSE HOLDER 30A 300V	1
11	ELF732	LITTLE-FUSE 8A SLO-BLO	2
12	ELM735	SOLID STATE TIMER ICM FOR CH460,JAOP3-G, FC2-G AND E233	1
13	ELM614	OMRON STEAM TIMER H3DE	1
14	ELM720	OMRON CONTROL TIMER (11 PIN) H3CR (FOR OPTION DELAY)	1
AND	ELM729	11 PIN BASE (FOR OPTION DELAY)	1

Model : P240S-S5 (JAOP3-E DELAI VAP.)

View : INSIDE (See OVEN BACK)

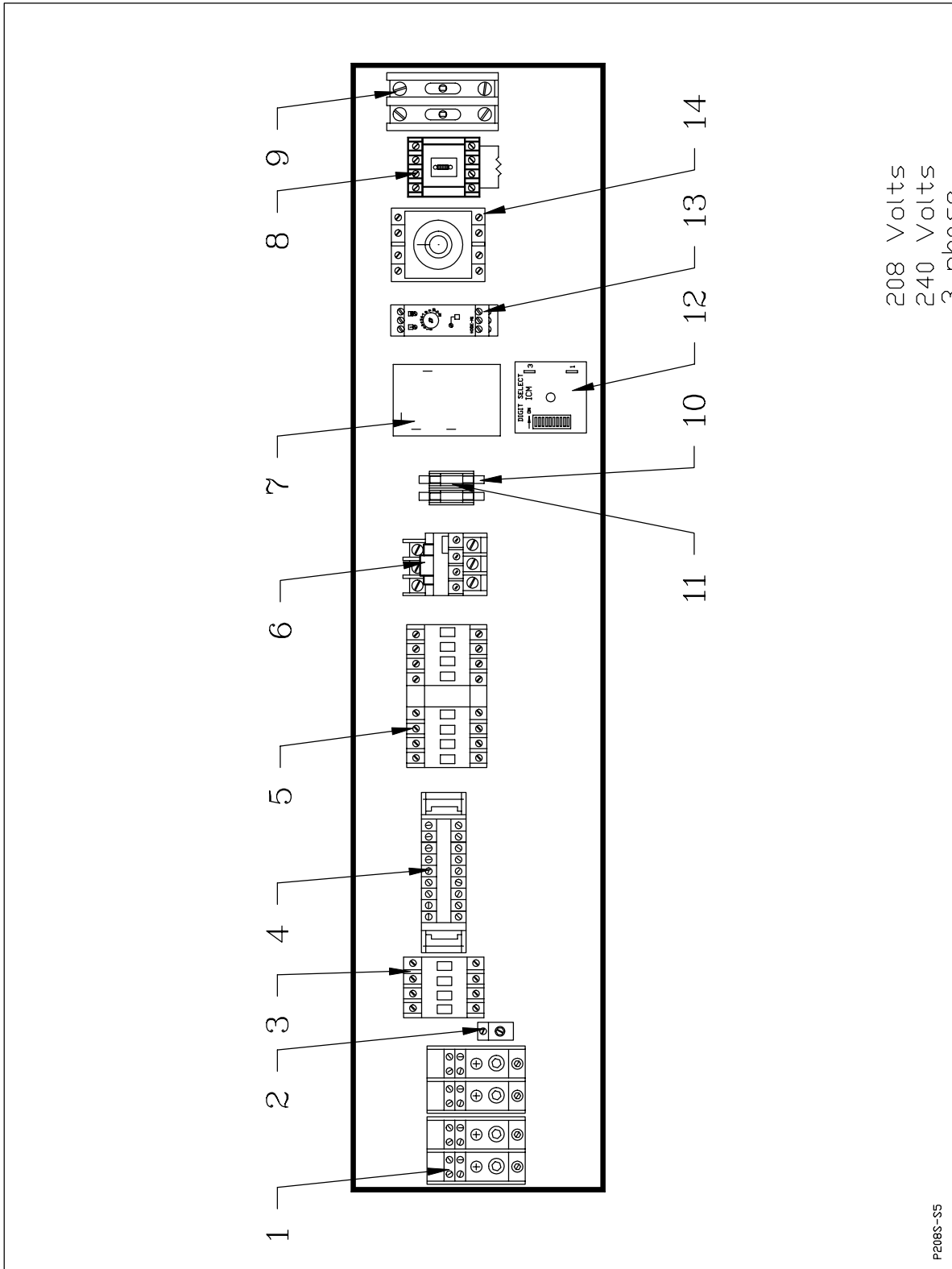

208 Volts
240 Volts
3 phase
Simple - JADP3DV

Item	Part Number	Description	Quantity
1	ELB071	TERMINAL BLOCK 2P 175A	2
2	ELL050	GROUND LUG	1
3	ELC908	HEATING CONTACTOR	1
	ELC909	HEATING CONTACTOR, COIL (ONLY)	
4	ELB073	TERMINAL BLOCK 30A	12
5	ELC515	MOTOR REVERSING CONTACTOR 2HP	1
	ELC520	CONTACTOR COIL (ONLY)	
6	ELO215	OVERLOAD RELAY SIMPLE PHASE 2 TO 7 AMPS.	1
AND	ELO220	OVERLOAD RELAY BASE	1
7	ELM715	PRESET TIMER 25SEC. OFF - 150SEC. ON	1
8	ELC615	RELAY 10A 2P COIL 110V	1
AND	ELC617	BASE	1
AND	ELM736	LOAD FOR TIMER	1
9	ELC860	CONTACTOR 2P 30A 110V	1
10	ELF960	LITTLE-FUSE HOLDER 30A 300V	1
11	ELF732	LITTLE-FUSE 8A SLO-BLO	2
12	ELM735	SOLID STATE TIMER ICM FOR CH460,JAOP3-G, FC2-G AND E233	1
13	ELM614	OMRON STEAM TIMER H3DE	1
14	ELM720	OMRON CONTROL TIMER (11 PIN) H3CR (FOR OPTION DELAY)	1
AND	ELM729	11 PIN BASE (FOR OPTION DELAY)	1

Model : P208S-S5 (JAOP3-E DELAI VAP.)

View : INSIDE (See OVEN BACK)

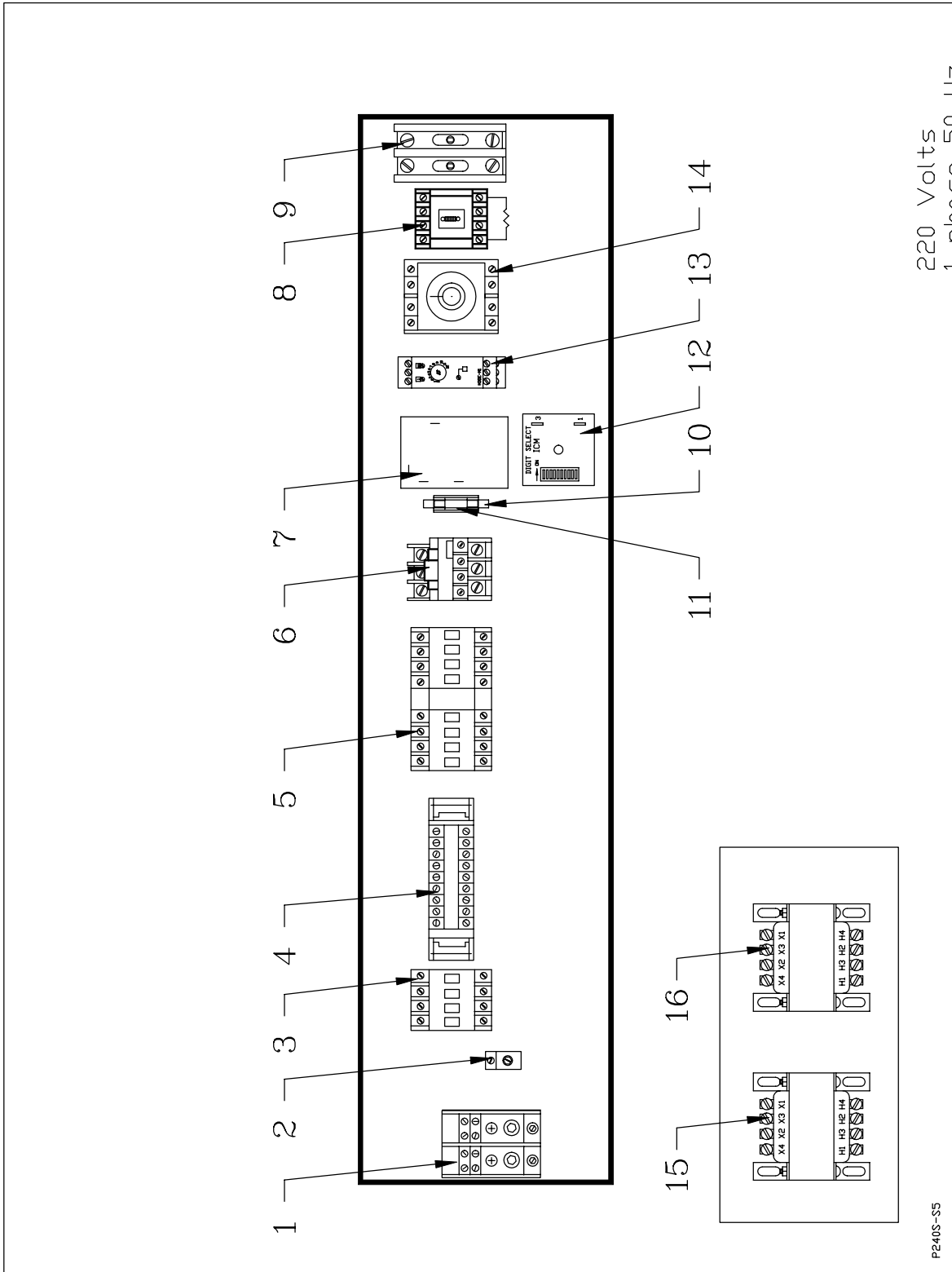

220 Volts
1 phase 50 Hz
Simple-JA0P3DV

Item	Part Number	Description	Quantity
1	ELB071	TERMINAL BLOCK 2P 175A	1
2	ELL050	GROUND LUG	1
3	ELC908	HEATING CONTACTOR	1
	ELC909	HEATING CONTACTOR, COIL (ONLY)	
4	ELB073	TERMINAL BLOCK 30A	12
5	ELC515	MOTOR REVERSING CONTACTOR 2HP	1
	ELC520	CONTACTOR COIL (ONLY)	
AND	ELC950	SPRECHER AUXILIARY CONTACT BLOCK	2
6	ELO215	OVERLOAD RELAY SIMPLE PHASE 2 TO 7 AMPS.	1
AND	ELO220	OVERLOAD RELAY BASE	1
7	ELM715	PRESET TIMER 25SEC. OFF - 150SEC. ON	1
8	ELC615	RELAY 10A 2P COIL 110V	1
AND	ELC617	BASE	1
AND	ELM736	LOAD FOR TIMER	1
9	ELC860	CONTACTOR 2P 30A 110V	1
10	ELF960	LITTLE-FUSE HOLDER 30A 300V	1
11	ELF732	LITTLE-FUSE 8A SLO-BLO	2
12	ELM735	SOLID STATE TIMER ICM FOR CH460,JAOP3-G, FC2-G AND E233	1
13	ELM614	OMRON STEAM TIMER H3DE	1
14	ELM720	OMRON CONTROL TIMER (11 PIN) H3CR (FOR OPTION DELAY)	1
AND	ELM729	11 PIN BASE (FOR OPTION DELAY)	1
15	ELT712	TRANSFORMER 240/120 50VA	1
OR	ELT725	TRANSFORMER 240/120 250VA	1
16	ELT715	TRANSFORMER 240>120 100VA	1
OR	ELT725	TRANSFORMER 240/120 250VA	1

Model : P240S-S5208

View : INSIDE (See OVEN BACK)

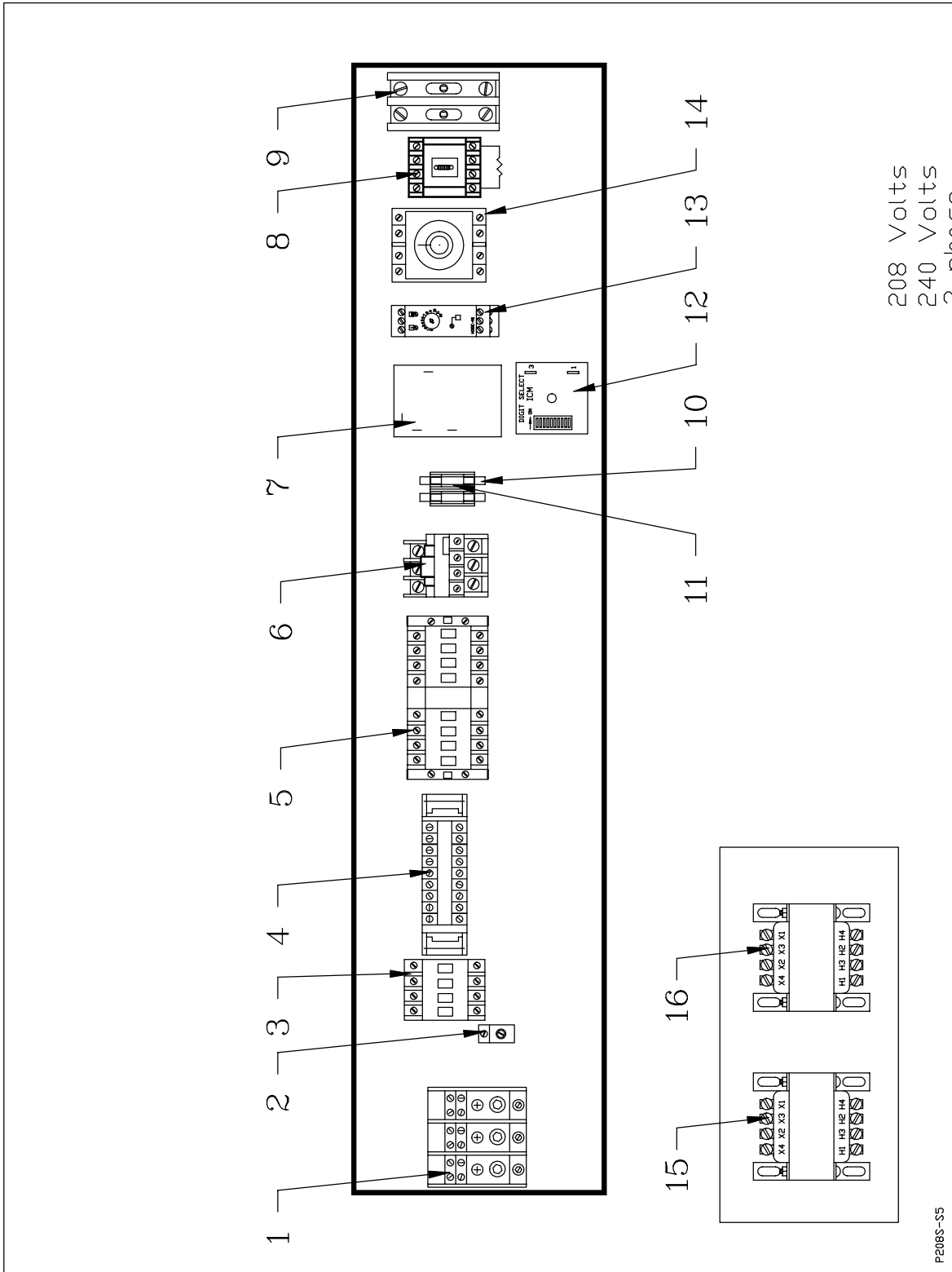

208 Volts
240 Volts
3 phase
Simple-JADP3DV

Item	Part Number	Description	Quantity
1	ELB072	TERMINAL BLOCK 3P 175A	1
2	ELL050	GROUND LUG	1
3	ELC908	HEATING CONTACTOR	1
	ELC909	HEATING CONTACTOR, COIL (ONLY)	
4	ELB073	TERMINAL BLOCK 30A	12
5	ELC515	MOTOR REVERSING CONTACTOR 2HP	1
	ELC520	CONTACTOR COIL (ONLY)	
AND	ELC950	SPRECHER AUXILIARY CONTACT BLOCK	2
6	ELO215	OVERLOAD RELAY SIMPLE PHASE 2 TO 7 AMPS.	1
AND	ELO220	OVERLOAD RELAY BASE	1
7	ELM715	PRESET TIMER 25SEC. OFF - 150SEC. ON	1
8	ELC615	RELAY 10A 2P COIL 110V	1
AND	ELC617	BASE	1
AND	ELM736	LOAD FOR TIMER	1
9	ELC860	CONTACTOR 2P 30A 110V	1
10	ELF960	LITTLE-FUSE HOLDER 30A 300V	1
11	ELF732	LITTLE-FUSE 8A SLO-BLO	2
12	ELM735	SOLID STATE TIMER ICM FOR CH460,JAOP3-G, FC2-G AND E233	1
13	ELM614	OMRON STEAM TIMER H3DE	1
14	ELM720	OMRON CONTROL TIMER (11 PIN) H3CR (FOR OPTION DELAY)	1
AND	ELM729	11 PIN BASE (FOR OPTION DELAY)	1
15	ELT712	TRANSFORMER 240/120 50VA	1
OR	ELT725	TRANSFORMER 240/120 250VA	1
16	ELT715	TRANSFORMER 240>120 100VA	1
OR	ELT725	TRANSFORMER 240/120 250VA	1

Model : P240S-S5208(3PH)

View : INSIDE (See OVEN BACK)

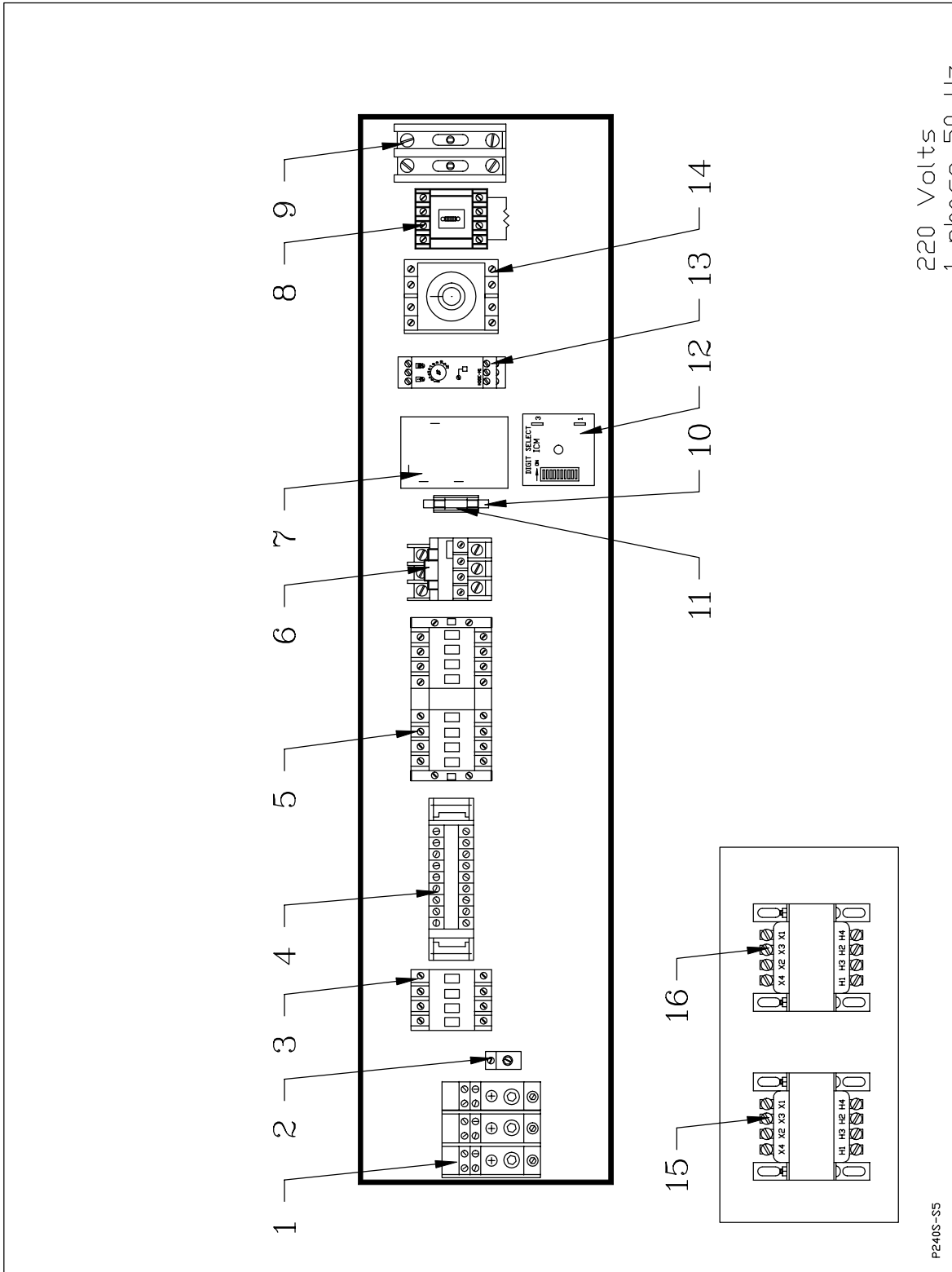

Item	Part Number	Description	Quantity
1	ELB071	TERMINAL BLOCK 2P 175A	1
2	ELL050	GROUND LUG	1
3	ELC908	HEATING CONTACTOR	1
	ELC909	HEATING CONTACTOR, COIL (ONLY)	
4	ELB073	TERMINAL BLOCK 30A	12
5	ELC515	MOTOR REVERSING CONTACTOR 2HP	1
	ELC520	CONTACTOR COIL (ONLY)	
AND	ELC950	SPRECHER AUXILIARY CONTACT BLOCK	2
6	ELO215	OVERLOAD RELAY SIMPLE PHASE 2 TO 7 AMPS.	1
AND	ELO220	OVERLOAD RELAY BASE	1
7	ELM715	PRESET TIMER 25SEC. OFF - 150SEC. ON	1
8	ELC615	RELAY 10A 2P COIL 110V	1
AND	ELC617	BASE	1
AND	ELM736	LOAD FOR TIMER	1
9	ELC860	CONTACTOR 2P 30A 110V	1
10	ELF960	LITTLE-FUSE HOLDER 30A 300V	1
11	ELF732	LITTLE-FUSE 8A SLO-BLO	1
12	ELM735	SOLID STATE TIMER ICM FOR CH460,JAOP3-G, FC2-G AND E233	1
13	ELM614	OMRON STEAM TIMER H3DE	1
14	ELM720	OMRON CONTROL TIMER (11 PIN) H3CR (FOR OPTION DELAY)	1
AND	ELM729	11 PIN BASE (FOR OPTION DELAY)	1
15	ELT712	TRANSFORMER 240/120 50VA	1
OR	ELT725	TRANSFORMER 240/120 250VA	1
16	ELT715	TRANSFORMER 240>120 100VA	1
OR	ELT725	TRANSFORMER 240/120 250VA	1

Model : JAOP3-97R (220V)

View : INSIDE (See OVEN BACK)

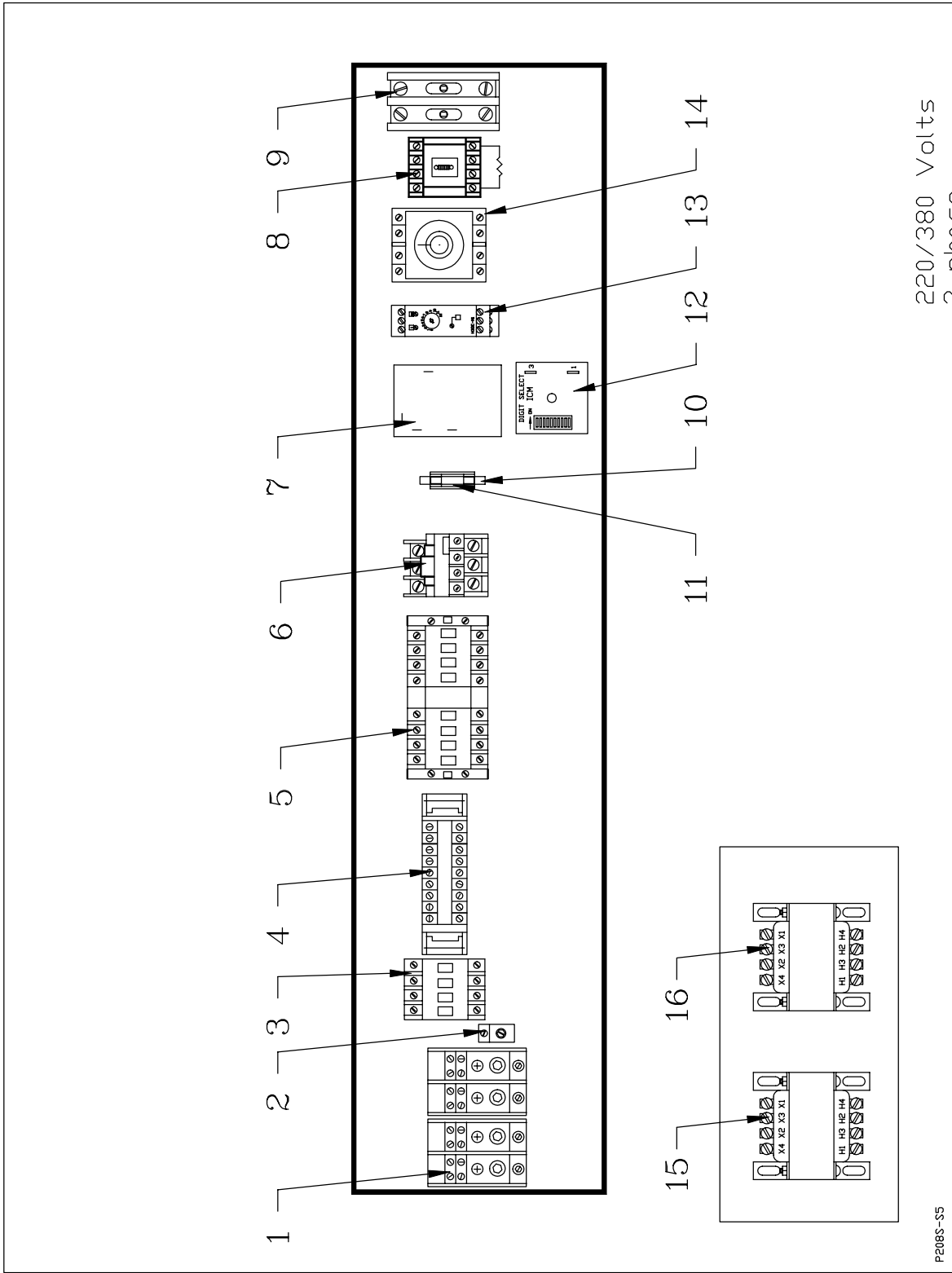

220/380 Volts
3 phase
Simple-JADP3DV

Item	Part Number	Description	Quantity
1	ELB071	TERMINAL BLOCK 2P 175A	2
2	ELL050	GROUND LUG	1
3	ELC908	HEATING CONTACTOR	1
	ELC909	HEATING CONTACTOR, COIL (ONLY)	
4	ELB073	TERMINAL BLOCK 30A	12
5	ELC515	MOTOR REVERSING CONTACTOR 2HP	1
	ELC520	CONTACTOR COIL (ONLY)	1
6	ELO215	OVERLOAD RELAY SIMPLE PHASE 2 TO 7 AMPS.	1
AND	ELO220	OVERLOAD RELAY BASE	1
7	ELM715	PRESET TIMER 25SEC. OFF - 150SEC. ON	1
8	ELC615	RELAY 10A 2P COIL 110V	1
AND	ELC617	BASE	1
AND	ELM736	LOAD FOR TIMER	1
9	ELC860	CONTACTOR 2P 30A 110V	1
10	ELF960	LITTLE-FUSE HOLDER 30A 300V	1
11	ELF732	LITTLE-FUSE 8A SLO-BLO	1
12	ELM735	SOLID STATE TIMER ICM FOR CH460,JAOP3-G, FC2-G AND E233	1
13	ELM614	OMRON STEAM TIMER H3DE	1
14	ELM720	OMRON CONTROL TIMER (11 PIN) H3CR(OPTION DELAY)	1
AND	ELM729	11 PIN BASE(OPTION DELAY)	1
15	ELT712	TRANSFORMER 240/120 50VA	1
OR	ELT725	TRANSFORMER 240/120 250VA	1
16	ELT715	TRANSFORMER 240>120 100VA	1
OR	ELT725	TRANSFORMER 240/120 250VA	1

Model : P208S-S5 (JAOP3-97 220/380/3)

View : INSIDE (See OVEN BACK)

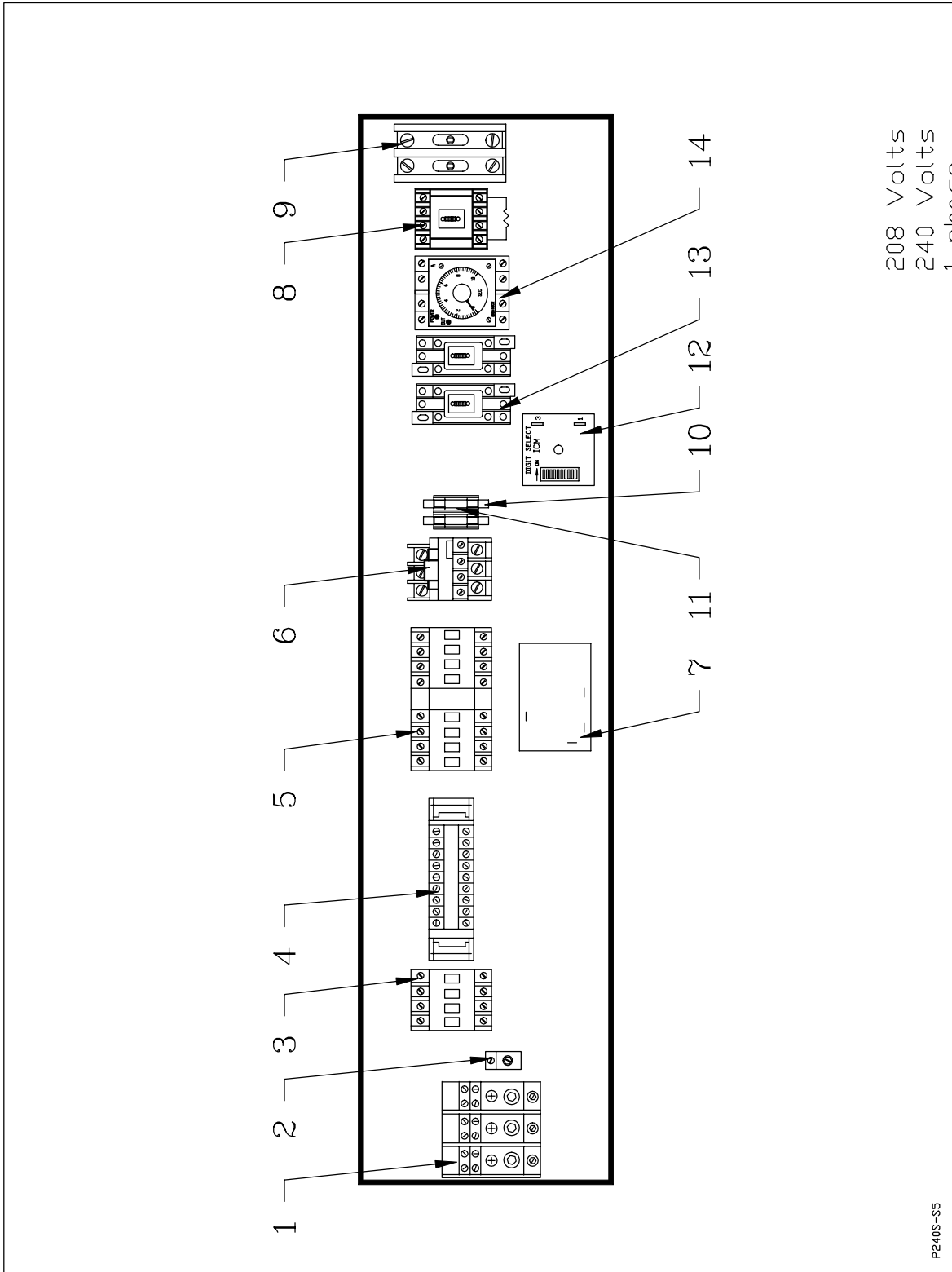

Item	Part Number	Description	Quantity
1	ELB072	TERMINAL BLOCK 3P 175A	1
2	ELL050	GROUND LUG	1
3	ELC908	HEATING CONTACTOR	1
	ELC909	HEATING CONTACTOR, COIL (ONLY)	
4	ELB073	TERMINAL BLOCK 30A	12
5	ELC515	MOTOR REVERSING CONTACTOR 2HP	1
	ELC520	CONTACTOR COIL (ONLY)	
6	ELO215	OVERLOAD RELAY SIMPLE PHASE 2 TO 7 AMPS.	1
AND	ELO220	OVERLOAD RELAY BASE	1
7	ELM715	PRESET TIMER 25SEC. OFF - 150SEC. ON	1
8	ELC615	RELAY 10A 2P COIL 110V	1
AND	ELC617	BASE	1
AND	ELM736	LOAD FOR TIMER	1
9	ELC860	CONTACTOR 2P 30A 110V	1
10	ELF960	LITTLE-FUSE HOLDER 30A 300V	2
11	ELF732	LITTLE-FUSE 8A SLO-BLO	2
12	ELM735	SOLID STATE TIMER ICM FOR CH460,JAOP3-G, FC2-G AND E233	1
13	ELC630	CONTROL RELAY 12A COIL 120V	2
AND	ELC640	CONTROL RELAY BASE	2
14	ELM720	OMRON CONTROL TIMER (11 PIN) H3CR	1
AND	ELM729	11 PIN BASE	1

Model : P240S-S5 (WATLOW)

View : INSIDE (See OVEN BACK)

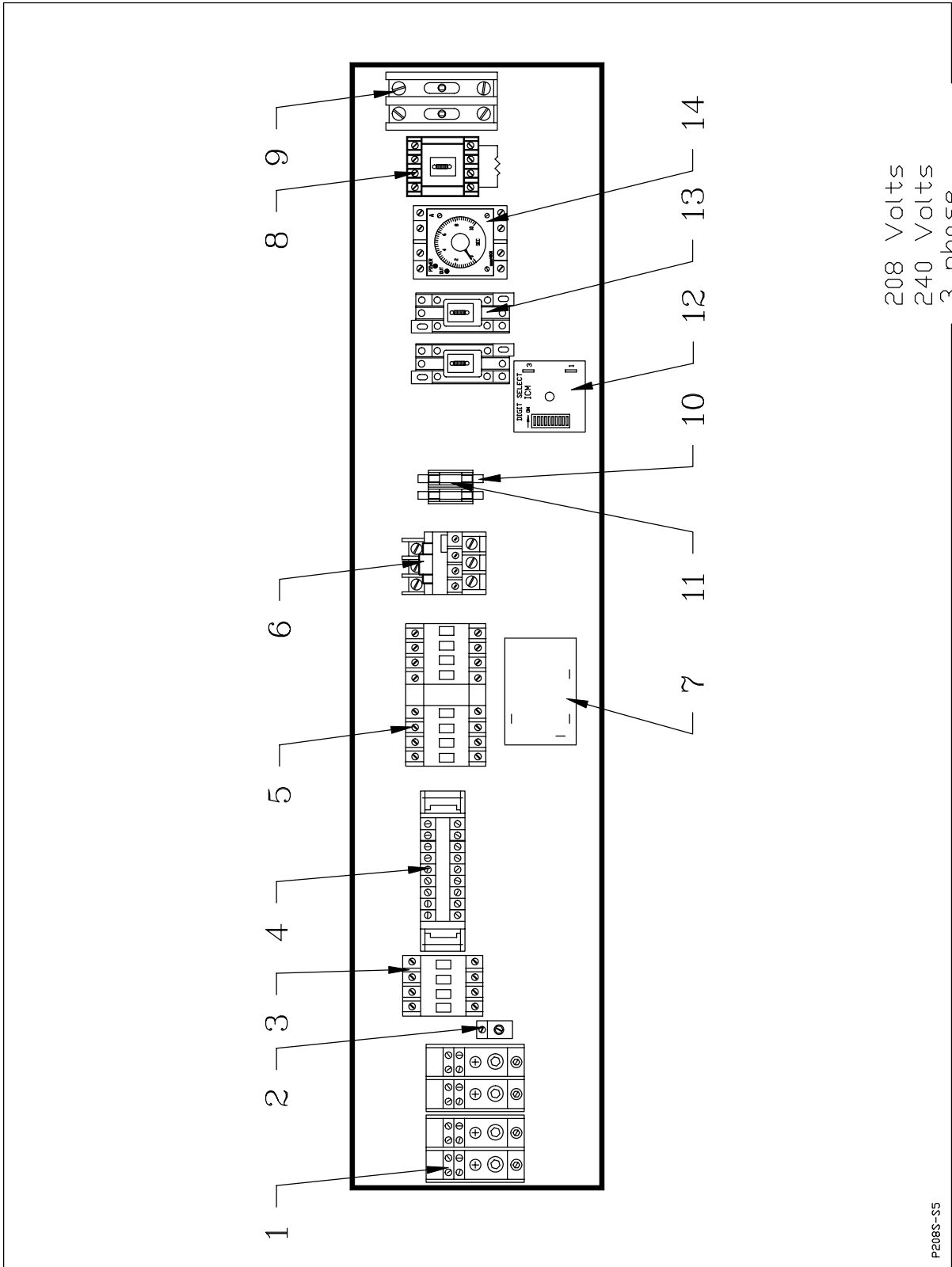

Item	Part Number	Description	Quantity
1	ELB071	TERMINAL BLOCK 2P 175A	2
2	ELL050	GROUND LUG	1
3	ELC908	HEATING CONTACTOR	1
	ELC909	HEATING CONTACTOR, COIL (ONLY)	
4	ELB073	TERMINAL BLOCK 30A	12
5	ELC515	MOTOR REVERSING CONTACTOR 2HP	1
	ELC520	CONTACTOR COIL (ONLY)	
6	ELO215	OVERLOAD RELAY SIMPLE PHASE 2 TO 7 AMPS.	1
AND	ELO220	OVERLOAD RELAY BASE	1
7	ELM715	PRESET TIMER 25SEC. OFF - 150SEC. ON	1
8	ELC615	RELAY 10A 2P COIL 110V	1
AND	ELC617	BASE	1
AND	ELM736	LOAD FOR TIMER	1
9	ELC860	CONTACTOR 2P 30A 110V	1
10	ELF960	LITTLE-FUSE HOLDER 30A 300V	2
11	ELF732	LITTLE-FUSE 8A SLO-BLO	2
12	ELM735	SOLID STATE TIMER ICM FOR CH460,JAOP3-G, FC2-G AND E233	1
13	ELC630	CONTROL RELAY 12A COIL 120V	2
AND	ELC640	CONTROL RELAY BASE	2
14	ELM720	OMRON CONTROL TIMER (11 PIN) H3CR	1
AND	ELM729	11 PIN BASE	1

Model : P208S-S5 (WATLOW)

View : INSIDE (See OVEN BACK)

SECTION
G

ELECTRIC SCHEMATICS

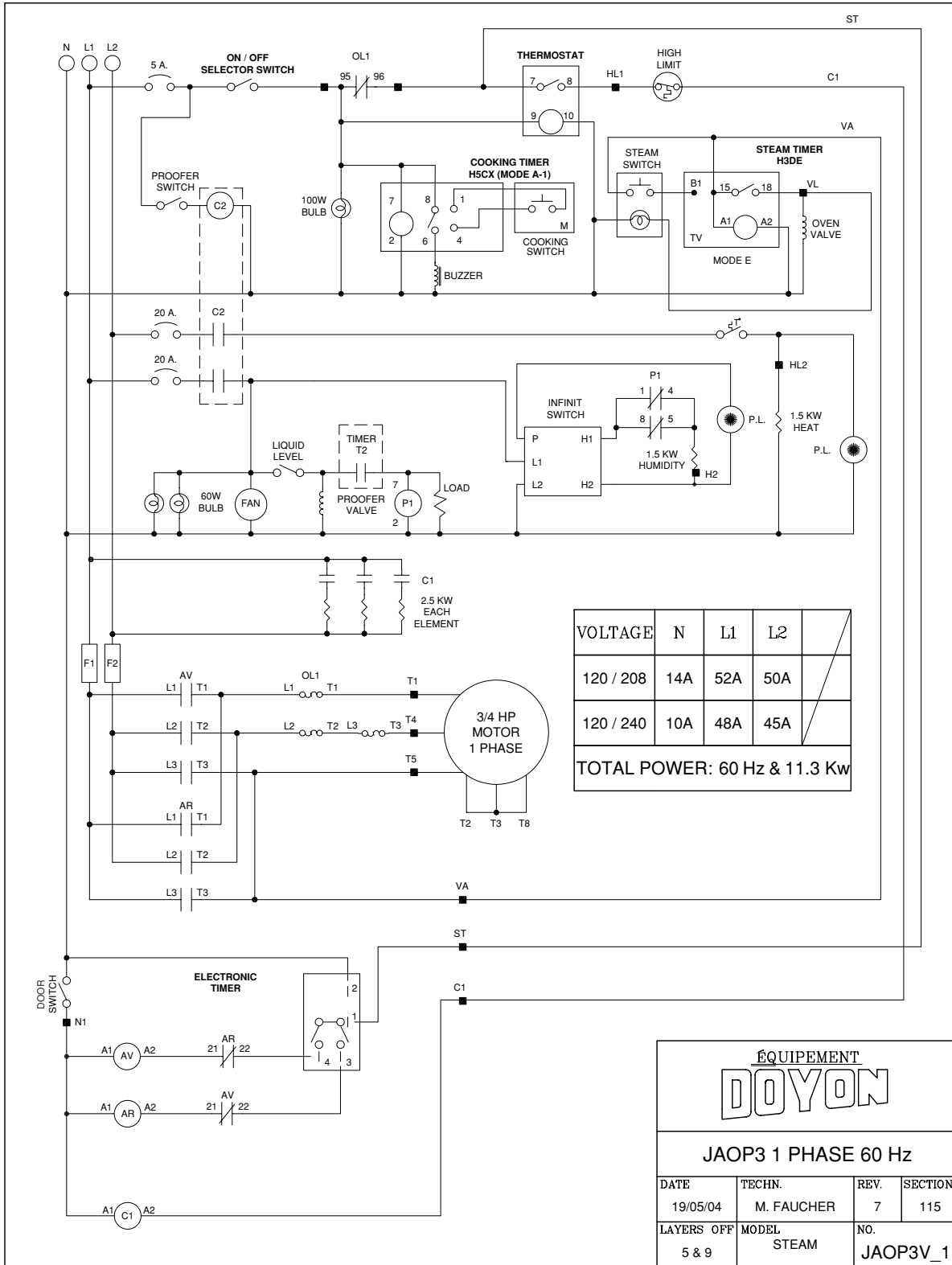

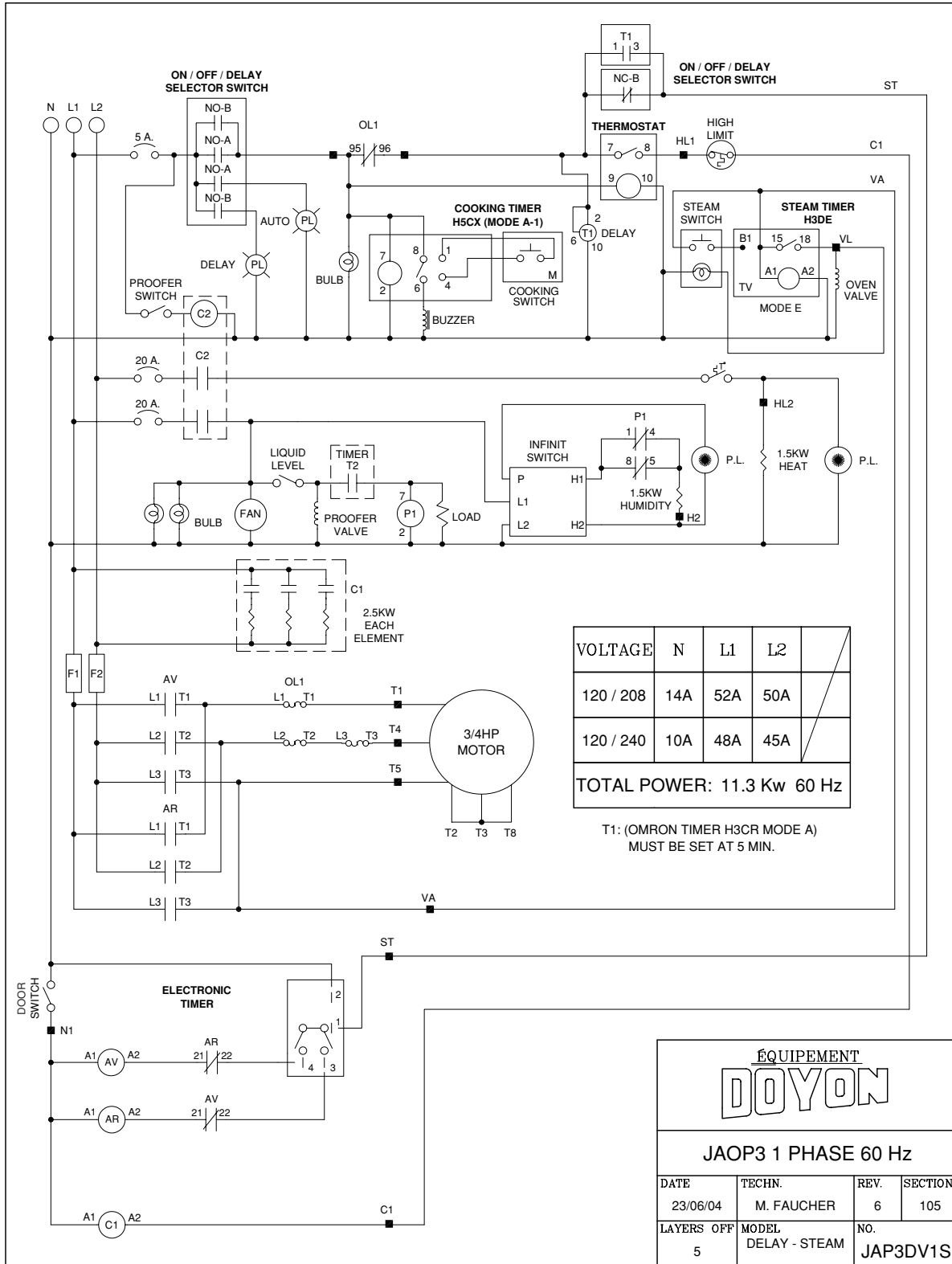

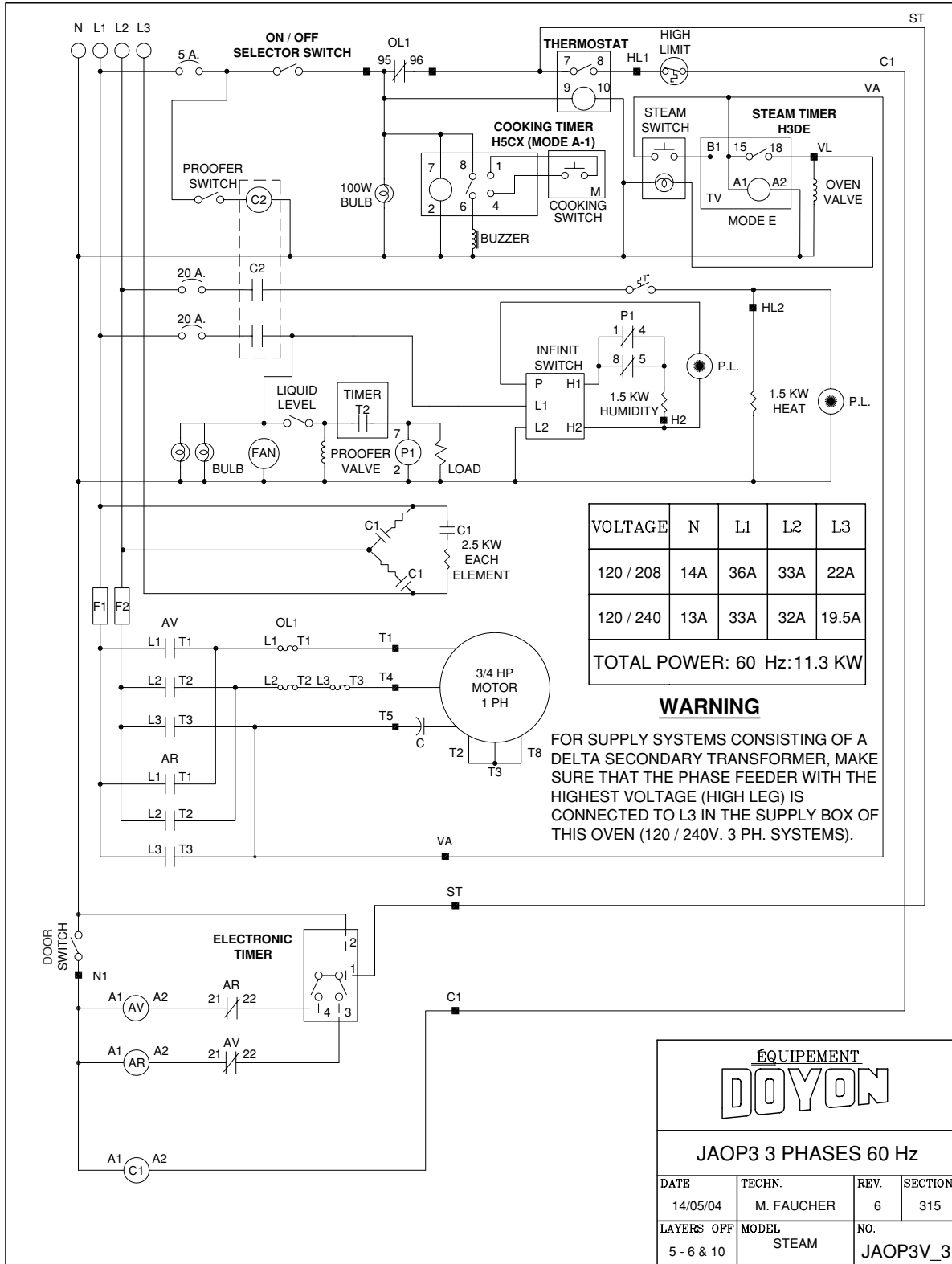

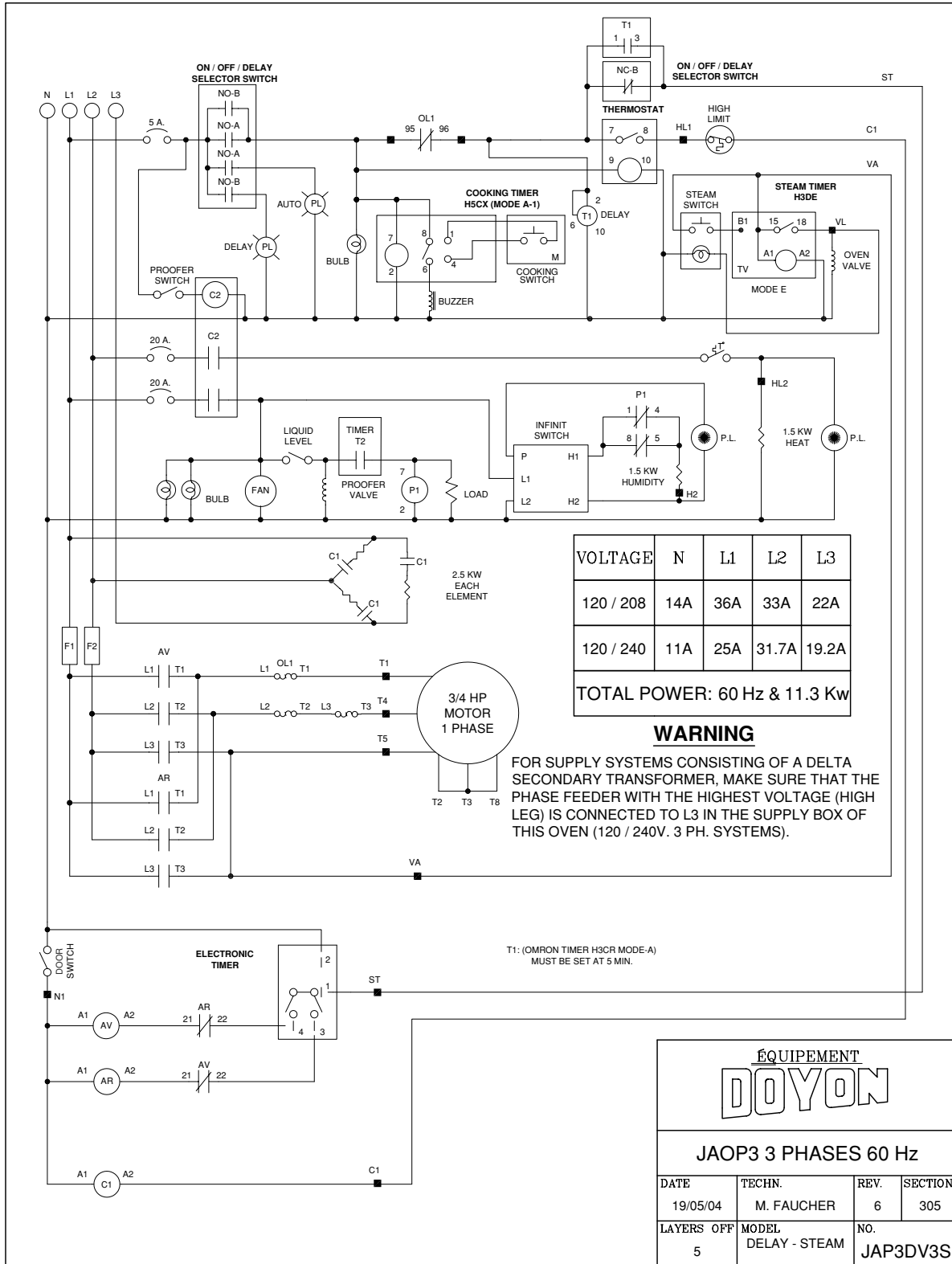

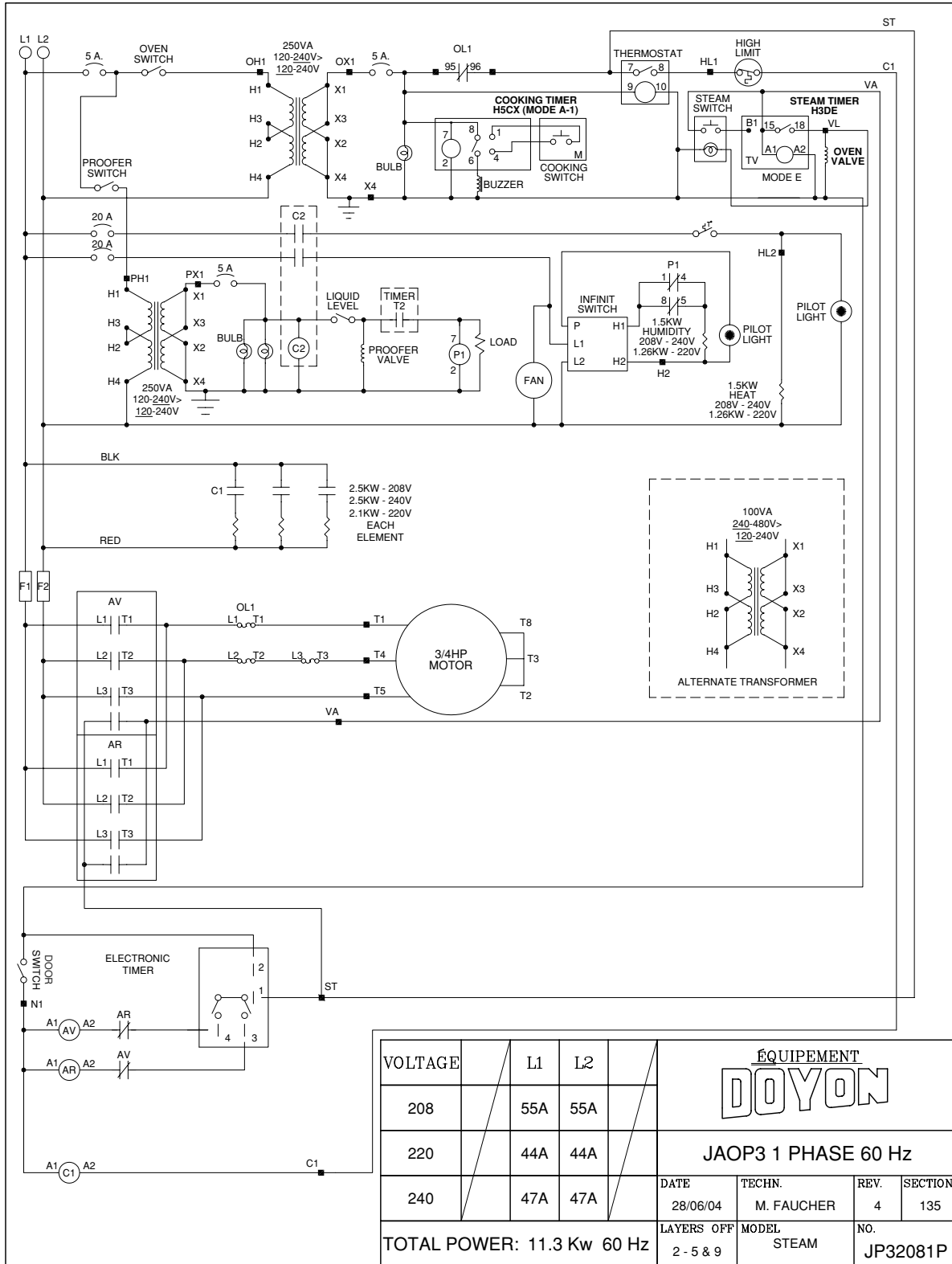

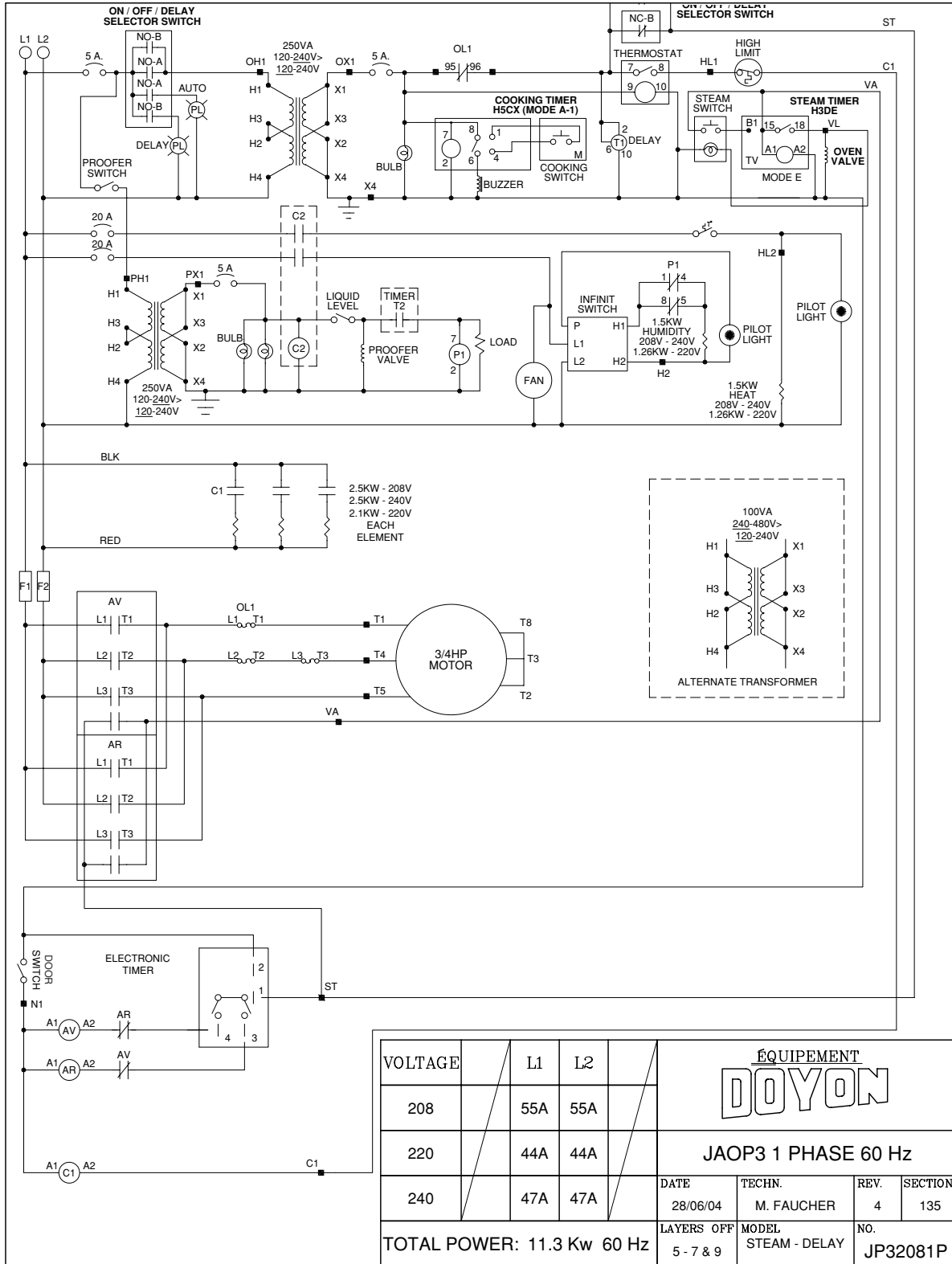

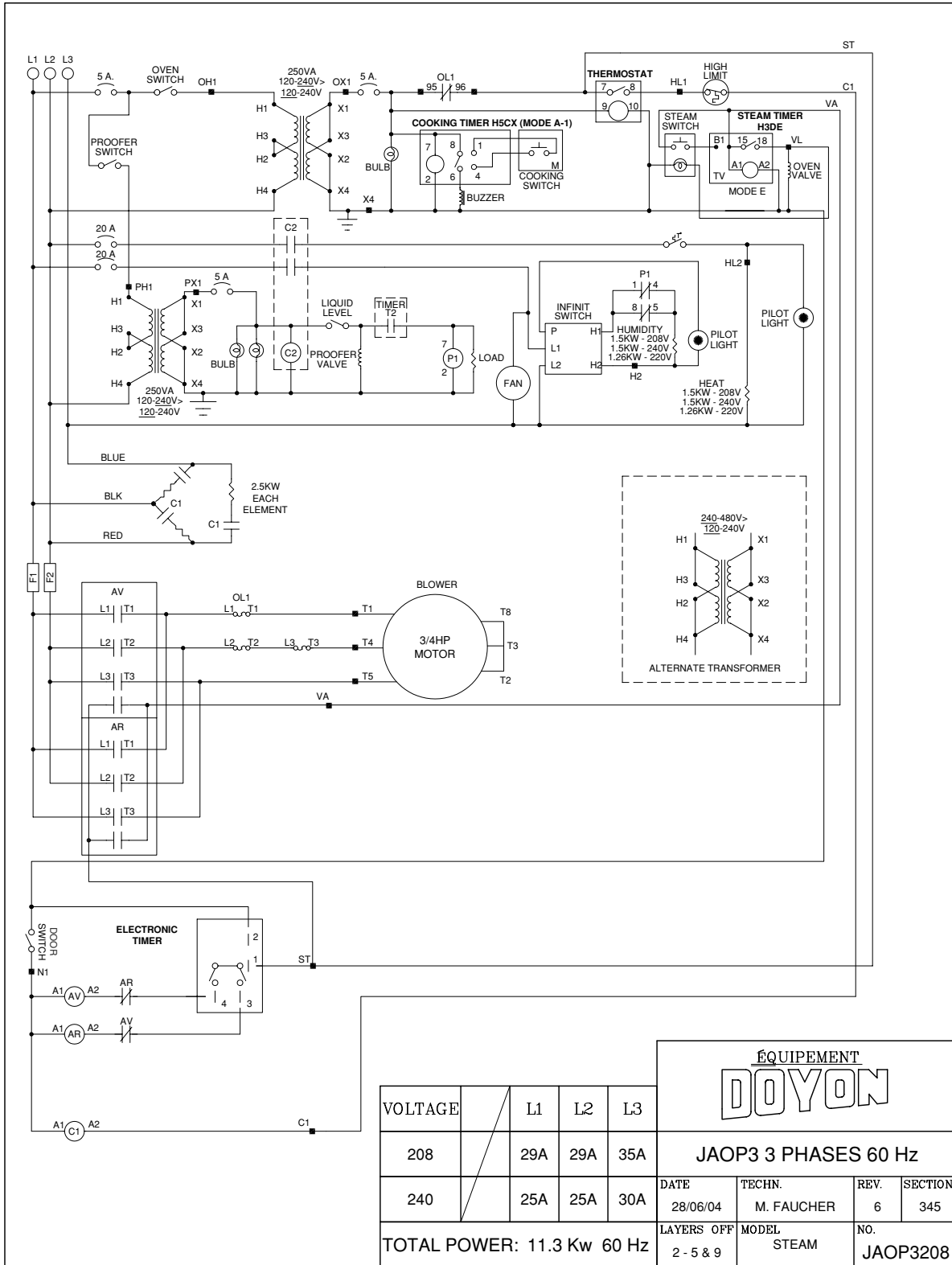

VOLTAGE	L1	L2	L3
208	29A	29A	35A
240	25A	25A	30A
TOTAL POWER: 11.3 Kw 60 Hz			

EQUIPEMENT
DOYON

JAOP3 3 PHASES 60 Hz

DATE	TECHN.	REV.	SECTION
28/06/04	M. FAUCHER	6	345
LAYERS OFF	MODEL	NO.	
2 - 5 & 9	STEAM	JAOP3208	

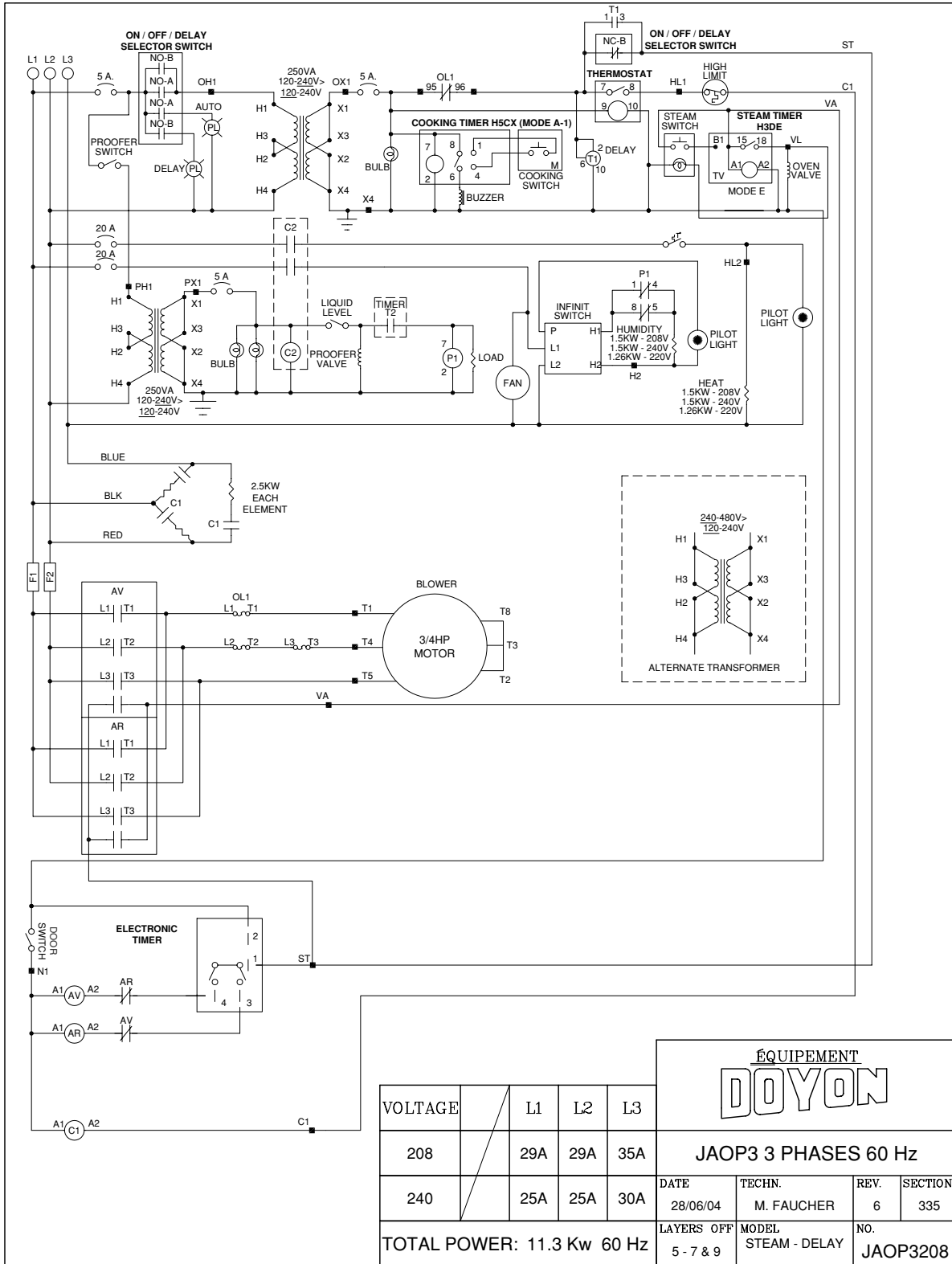

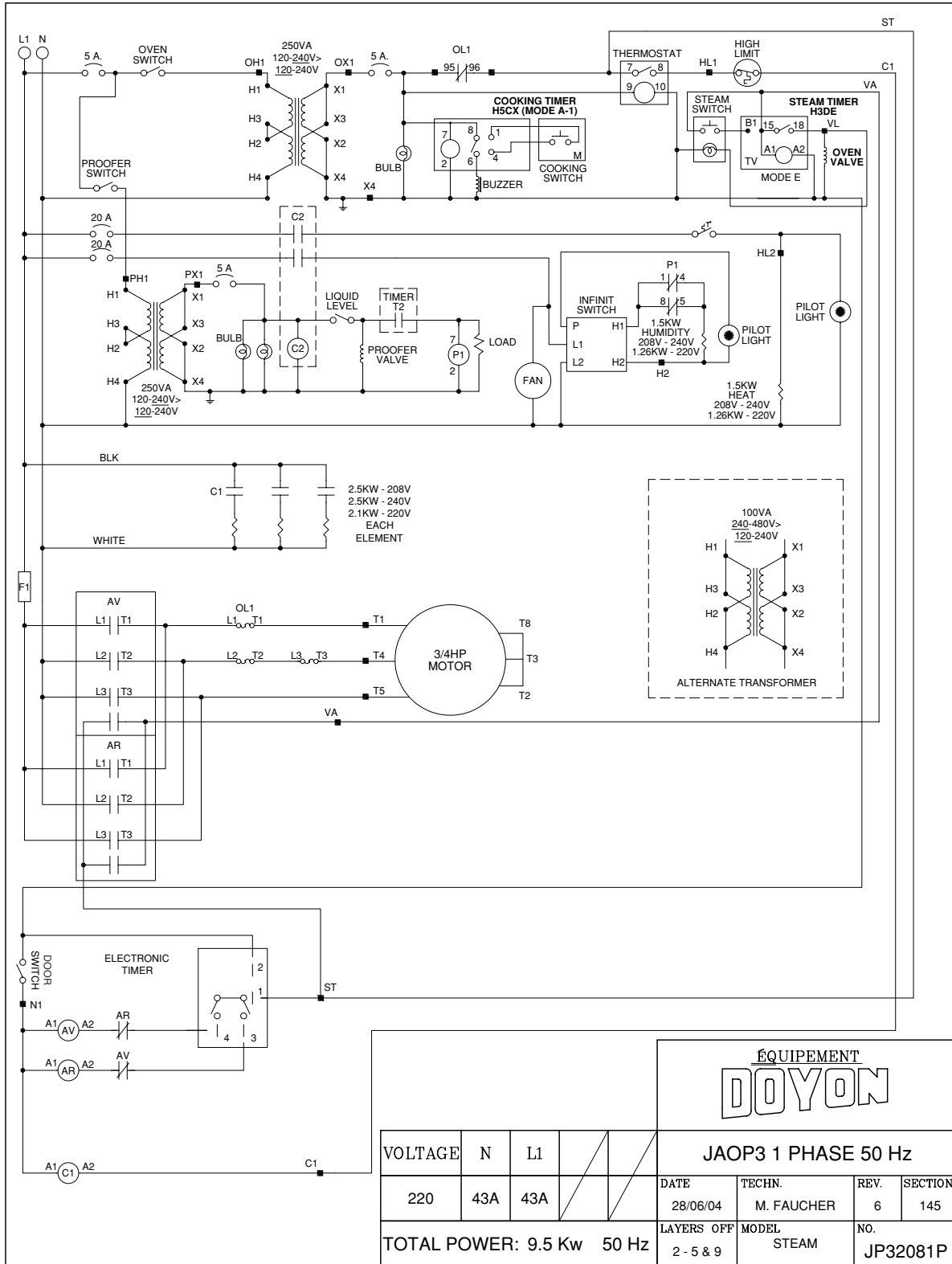

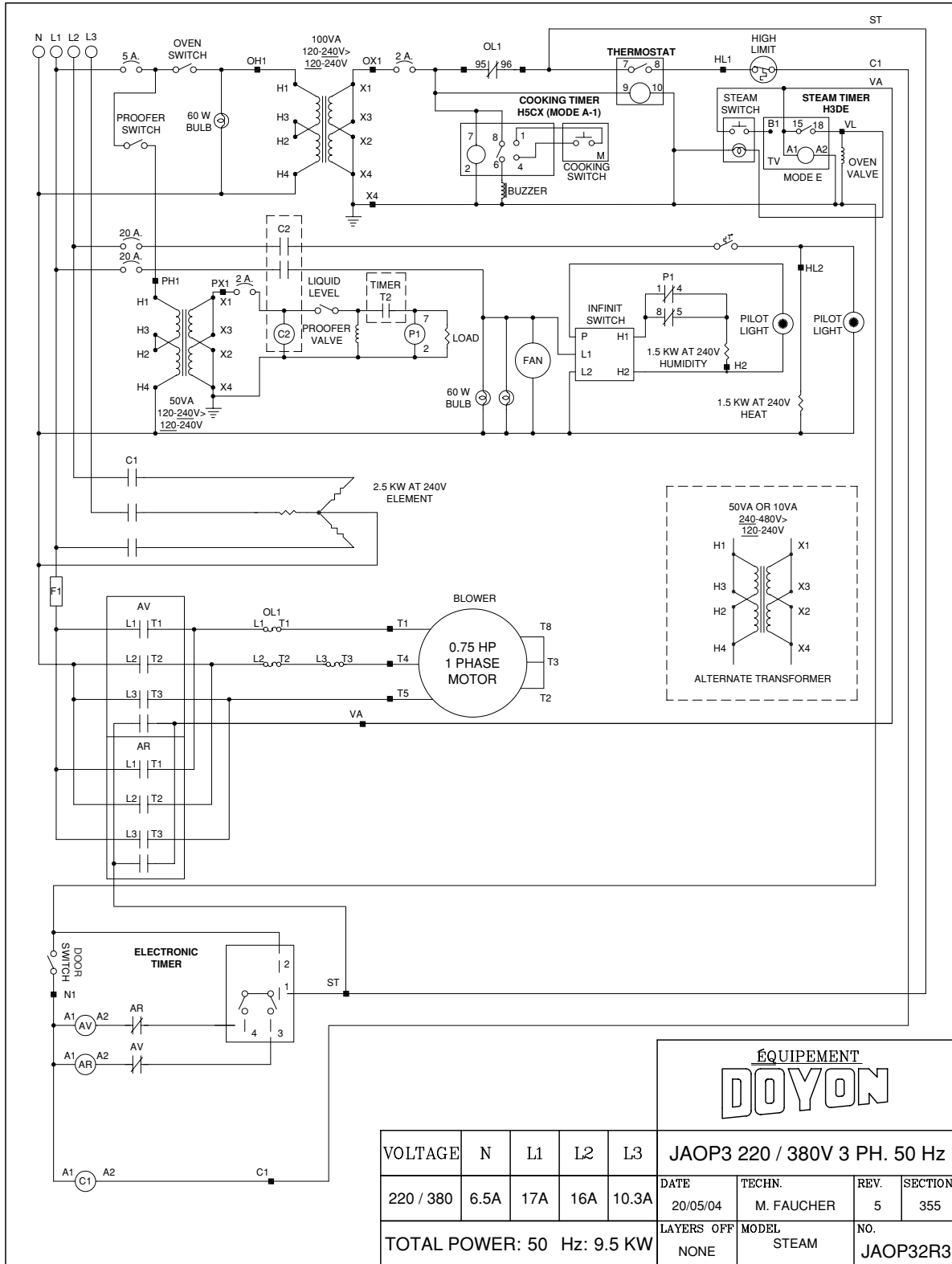

G-11

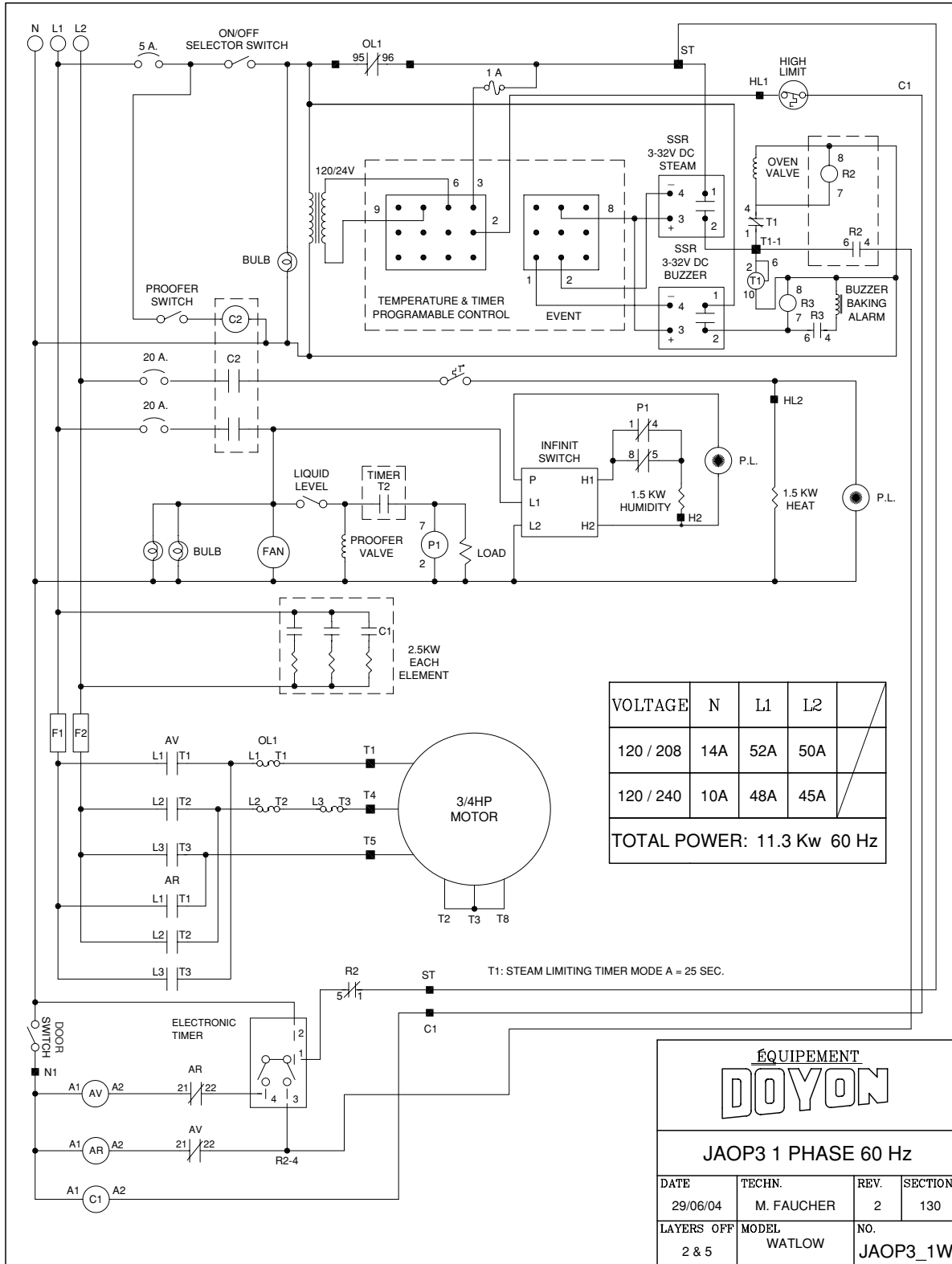

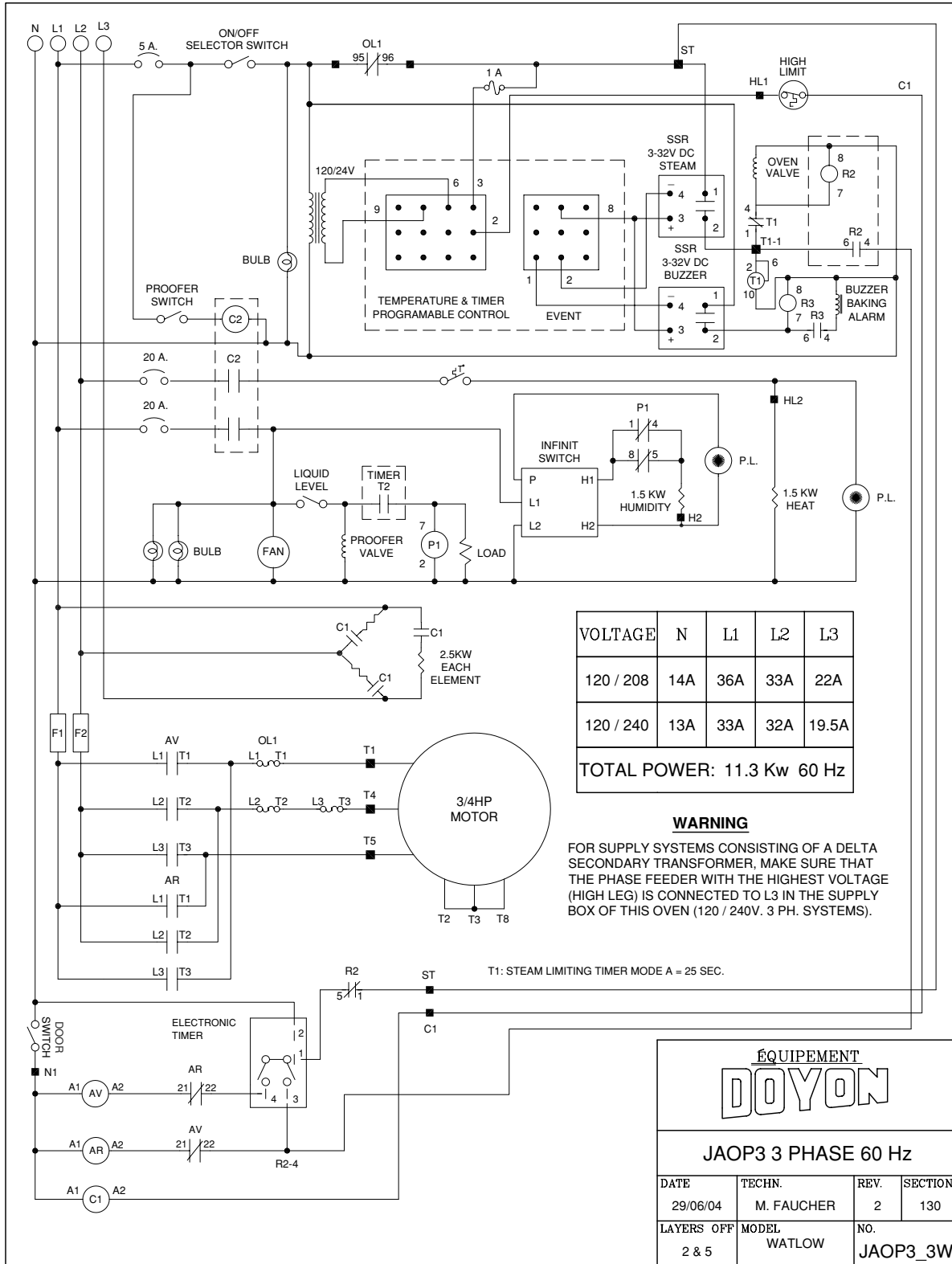

EQUIPEMENT			
DOYON			
JAOP3 3 PHASE 60 Hz			
DATE	TECHN.	REV.	SECTION
29/06/04	M. FAUCHER	2	130
LAYERS OFF	MODEL	NO.	
2 & 5	WATLOW	JAOP3_3W	

LIMITED WARRANTY

(Continental United States Of America And Canada Only)

Doyon Equipment Inc. guarantees to the original purchaser only that its product are free of defects in material and workmanship, under normal use.

This warranty does not cover any light bulbs, thermostat calibration or defects due to or resulting from handling, abuse, misuse, nor shall it extend to any unit from which the serial number has been removed or altered, or modifications made by unauthorized service personnel or damage by flood, fire or other acts of God. Nor will this warranty apply as regards to the immersion element damaged by hard water.

The extent of the manufacturer's obligation under this warranty shall be limited to the replacement or repair of defective parts within the warranty period. The decision of the acceptance of the warranty will be made by Doyon Equipment service department, which decision will be final.

The purchaser is responsible for having the equipment properly installed, operated under normal conditions with proper supervision and to perform periodic preventive maintenance.

If any parts are proven defective during the period of one year from date of purchase, Doyon Equipment Inc. hereby guarantees to replace, without charge, F.O.B. Linière, Quebec, Canada, such part or parts.

Doyon Equipment Inc will pay the reasonable labor charges in connection with the replacement parts occurring within one year from purchase date. Travel over 50 miles, holiday or overtime charges are not covered. After one year from purchase date, all labor and transportation charges in connection with replacement parts will be the purchaser's responsibility.

Doyon Equipment Inc. does hereby exclude and shall not be liable to purchaser for any consequential or incidental damages including, but not limited to, damages to property, damages for loss of use, loss of time, loss of profits or income, resulting from any breach or warranty.

In no case, shall this warranty apply outside Canada and continental United States unless the purchaser has a written agreement from Doyon Equipment Inc.