



NU-VU® Model:

SUB-123P

Oven / Proofer

SERVICE AND REPAIR MANUAL

Revised:
Sept 25, 2009

(SUB-123P-ServiceManual-01d)

(This page is intentionally left blank)

TABLE OF CONTENTS

TROUBLESHOOTING.....	1
Oven problems.....	1
Proofer problems.....	2
Controller problems.....	3
WATER FILTER INSTALLATION.....	4
HINGE REVERSAL.....	5
Oven Door Hinge Reversal.....	5
Proofer Door Hinge Reversal.....	6
CALIBRATION INSTRUCTIONS.....	7
PARTS LIST.....	8
ELECTRICAL SCHEMATICS.....	10 - 11

**LIST OF
ILLUSTRATIONS AND SCHEMATICS**

Drawing #1	Control Header	1
Drawing #2	Proofer Parts	2
Drawing #3	Control Adjustments.....	3
Drawing #4	Water Filter Installation	4
Drawing #5	Oven Door Hinge Reversal	5
Drawing #6	Proofer Door Hinge Reversal	6
Drawing #7	Calibration Instructions.....	7
Electrical Schematics		10 – 11
Exploded Views		12-13

(This page is intentionally left blank)

Troubleshooting Guide

Oven Problems

The oven doesn't heat up.....

Is there an asterisk next to the oven temperature on the display?

Yes – Is the contactor engaged?

Yes – Is the oven fan rotating?

Yes – Check oven elements.

Oven elements OK – Replace contactor

Oven elements not OK – Replace oven element(s)

No – Is the motor wired correctly?

Yes – Replace oven motor assembly

No – Correct wiring problem

No – Check Hi-Limit switch.

Hi-Limit switch OK – Replace contactor

Hi-Limit switch not OK – Replace Hi-Limit switch

No – Is the actual oven temperature on the display higher than the set-point?

Yes – Replace oven temperature sensor

No – Is there a plus sign next to the oven temperature on the display?

Yes – Check oven door switch

The oven motor doesn't rotate

Is there a plus sign next to the oven temperature on the display?

Yes – Check oven door switch

No – Is the oven motor wired correctly?

Yes – Replace oven motor assembly

No – Correct wiring problem

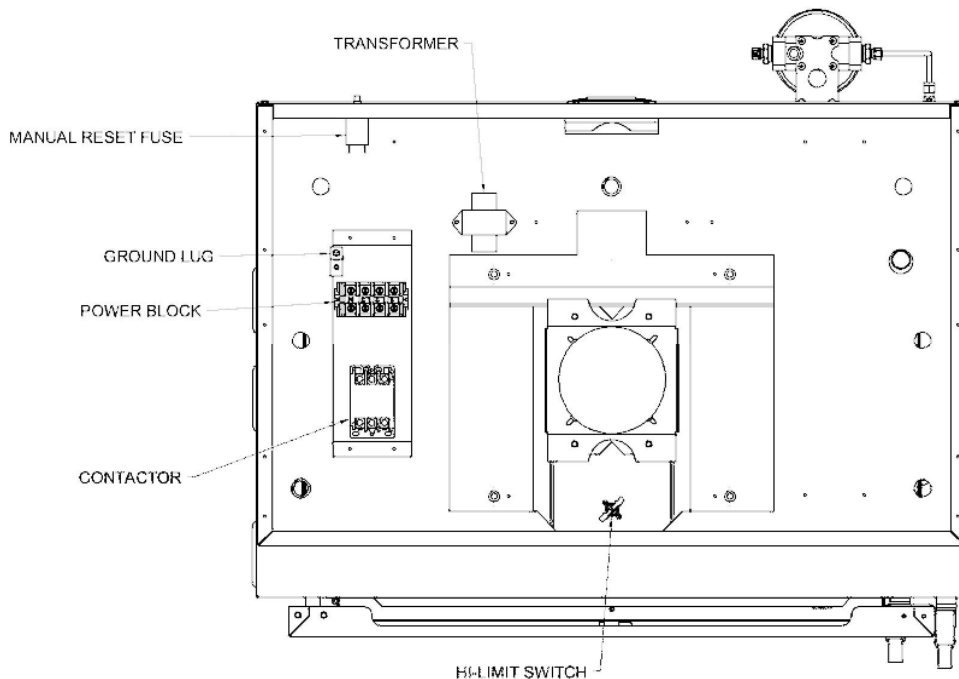

Drawing 1

Proofer Problems

The proofer is not heating up

Does the proofer display read "SENSOR" or "SENSOR FAULT"?

Yes – Cycle power to entire unit off then back on

Does the proofer display still read "SENSOR"?

Yes – Replace proofer sensor

No- Is there an asterisk next to the proofer temperature on the display?

Yes – Check proofer heating elements

No – Is the actual proofer temperature on the display higher than the set-point?

Yes – Replace proofer sensor

There is no moisture in the proofer

Is there a water line connected to the unit?

Yes – Is the water line to the unit turned on?

Yes – Is there an asterisk next to the proofer humidity on the display?

Yes – Remove proofer element cover

Is the nozzle spraying water? (It should spray every 20 seconds)

No – Can you hear the solenoid click?

Yes – Clean nozzle

No – Replace solenoid

No - Is the actual humidity on the display higher than the set-point?

Yes – Replace proofer sensor

No – Turn on water supply to the unit

No – Connect a water line to the unit and turn the water supply on

The display reads "CHECK WATER SUPPLY"

To clear the message, press the enter button. After clearing the message, check that the water supply is connected and is turned on. Also verify that the nozzle is spraying water.

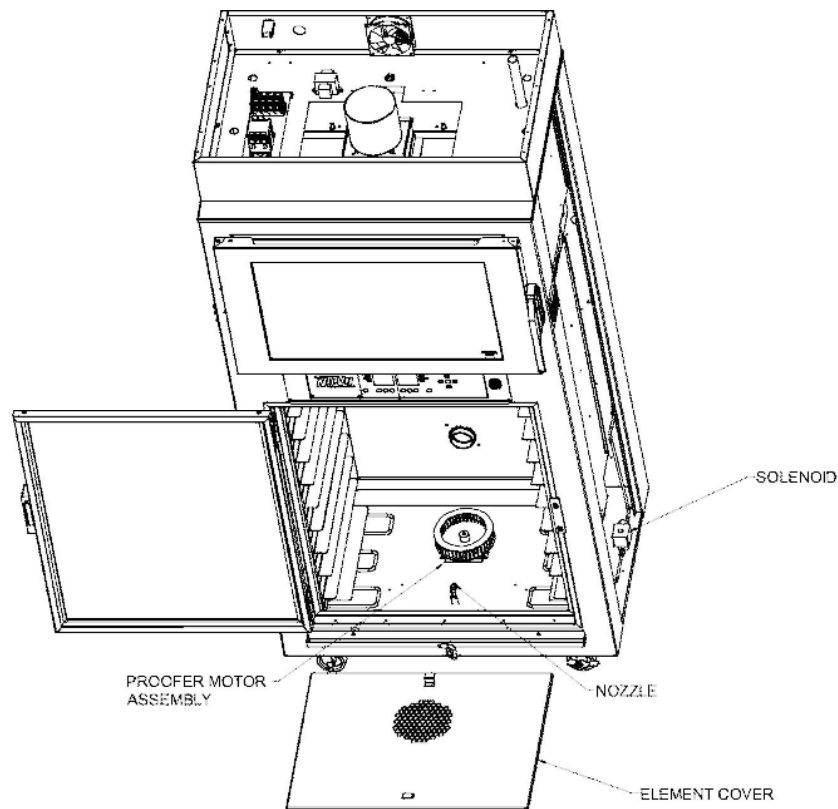

Drawing 2

Controller problems

The controller display doesn't power up.....

Do the interior lights come on when the power buttons are pressed?

Yes – Adjust the LCD contrast, did this correct the problem?

No – Replace controller

No – Check output from transformer (output voltage should be 20 – 30 VAC)

Output voltage is OK – is there voltage at the power connections on the controller

Yes – Replace controller

No – Check the 15 pin connector for the controller

I don't want my employees to be able to change the recipe settings

Set DIP switch #2 to the off position (to the left)

I want the temperature to be displayed in Celsius

Set DIP switch # 3 to the on position (to the right)

How do I adjust the volume on the buzzer?.....

Turn the volume baffle on the buzzer until the desired volume is achieved

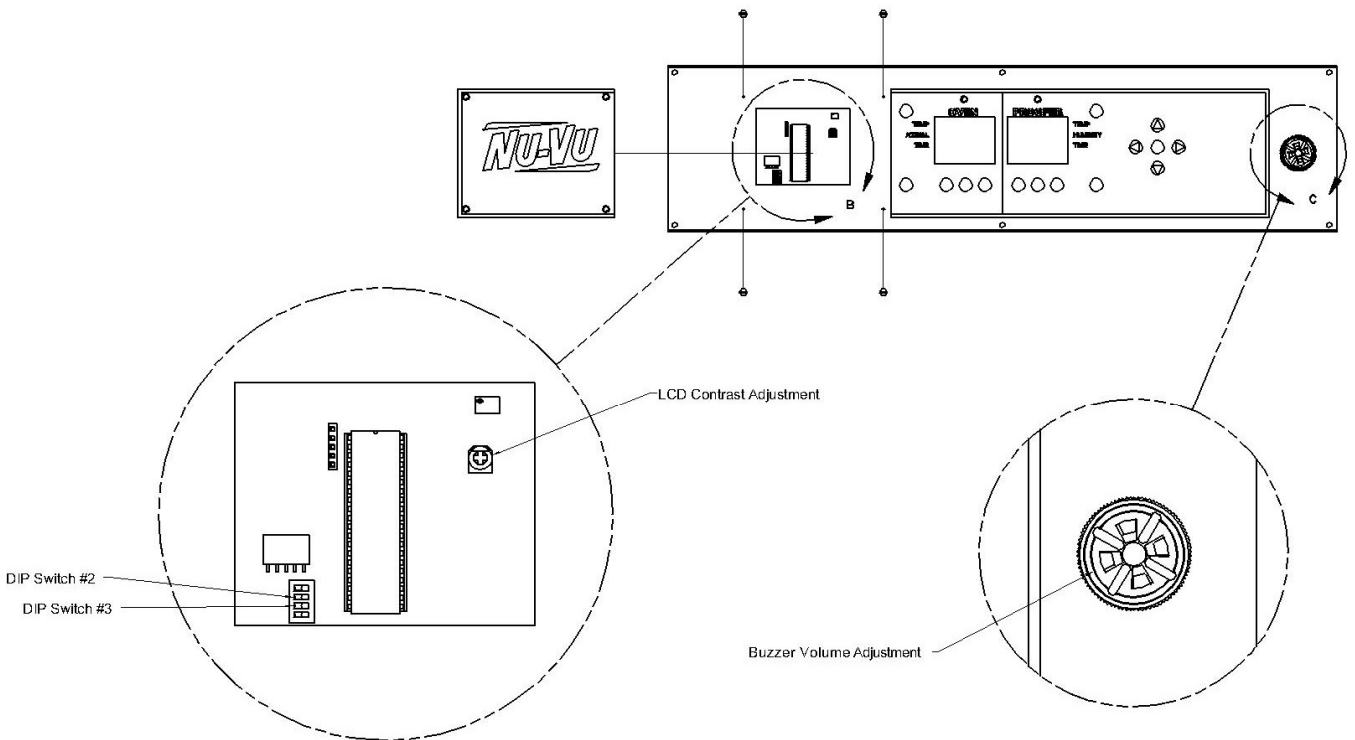

Drawing 3

Water Filter Installation

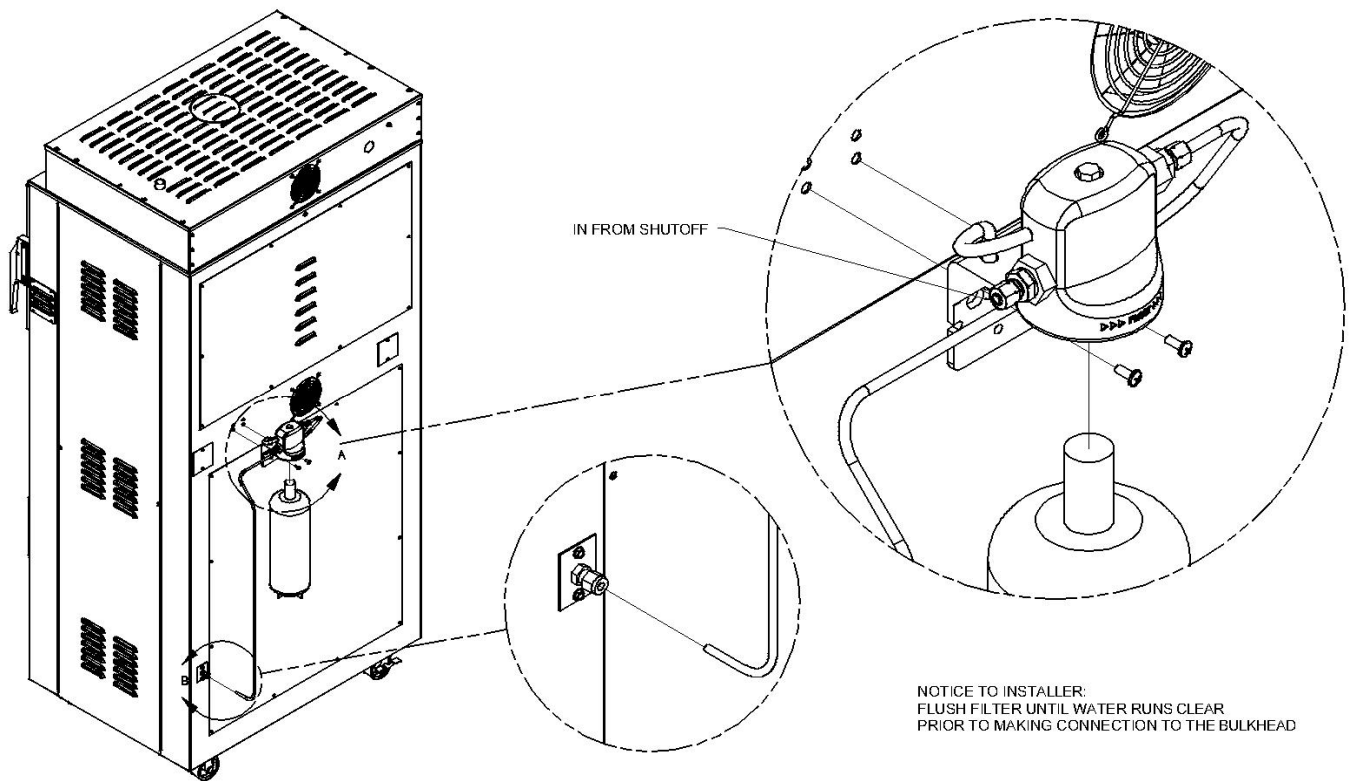

Drawing 4

1. Attach water filter bracket to the rear of the unit using the 10-32 screws the included with the filter assembly.
2. Run 1/4" OD tubing from the water supply line to the unit location. Allow some slack in the tubing for final unit positioning and any future service requirements. Avoid any kinks or strains on the tubing, and position the tubing where it will not be damaged in any way.
3. The tubing end that attaches to the back of the unit and filter must not be damaged or deformed in any way. The cut end should be cut straight and clean with no deforming of the tubing. All burrs and sharp or rough edges should be removed to ensure a proper and leak-free connection.
4. Position the tubing so that it runs straight into the intake Water Fitting on the rear of the unit. Be careful not to kink the tubing if you bend it, and do not bend the tubing within two (2) inches of the cut end.
5. The two-part compression fitting (tapered collar and nut) is placed approximately 1" onto the end of the tubing so that the collar is inside of the nut and the threaded opening of the nut is toward the intake Water Fitting.
6. Push the end of the tubing all the way into the intake Water Fitting (approximately 1/4") and hold it there while you thread the compression nut onto the intake Fitting. Tighten the compression nut with an open-end wrench, *but do not over-tighten the fitting!* If the joint leaks when tested, and further gently tightening does not stop the leakage, the compression fitting must be replaced.

OVEN DOOR HINGE REVERSAL

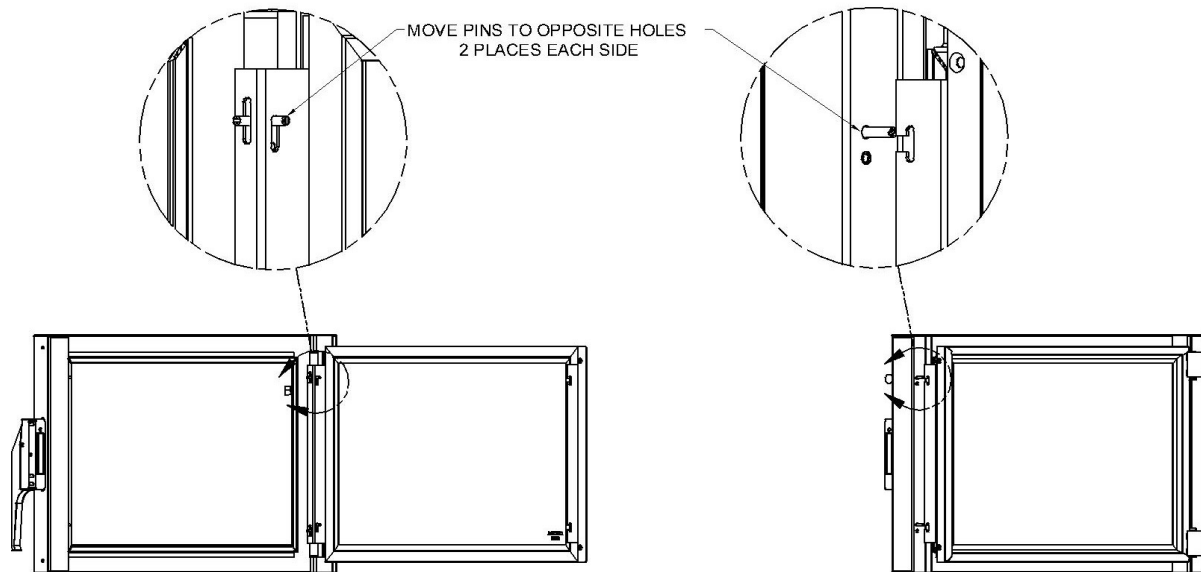

Drawing 5

Important: disconnect power before beginning

Tools Required:

5/16" hex key (Allen wrench)
 9/16" wrench or adjustable wrench
 Slotted screwdriver
 Phillips screwdriver

1. Remove both side panels and access covers (on sides, level with the door switch) using a slotted screwdriver.
2. Remove the oven door hinge bolts (4) using a 5/16" hex key.
3. With the door laying face down on a flat surface, open the inner door panel. Move the hinge and latch pins (one at a time) (note: the pins in the long slots do not need to be moved) to the holes next to the ones that they are in. Looking at the door from the front, the pins should be in the upper holes.
4. Remove the screws holding the latch onto the door, flip the latch over so that the handle points to the bottom of the door and re-install the screws.
5. Remove the door switch using a 9/16" wrench. Do not disconnect wires from the switch.
6. Remove metal plug from the door jamb opposite the door switch. If there isn't a hole opposite the door switch, a 1/2" hole will need to be drilled. A center punch will be in the jamb to locate the hole. If a hole must be drilled, remove all metal shavings afterwards.
7. Install the door switch in the 1/2" hole that you removed the metal plug from.
8. Install the metal plug that you removed in the old door switch hole.
9. Remove the bolts from the front face using a 9/16" wrench and install them in the holes that you removed the hinge bolts from.
10. Remove the screw on the latch strike plate using a Phillips screwdriver. Be careful not to lose the spacers or lock washers.
11. Install the latch strike plate on the opposite side of the front face. The screws should be centered top to bottom in the slots.
12. Re-install the oven door using the hinges bolts that you removed in step 2 earlier.
13. The door should now be tested to insure that it seals properly. (Refer to Door Test Procedure)

PROOFER DOOR HINGE REVERSAL

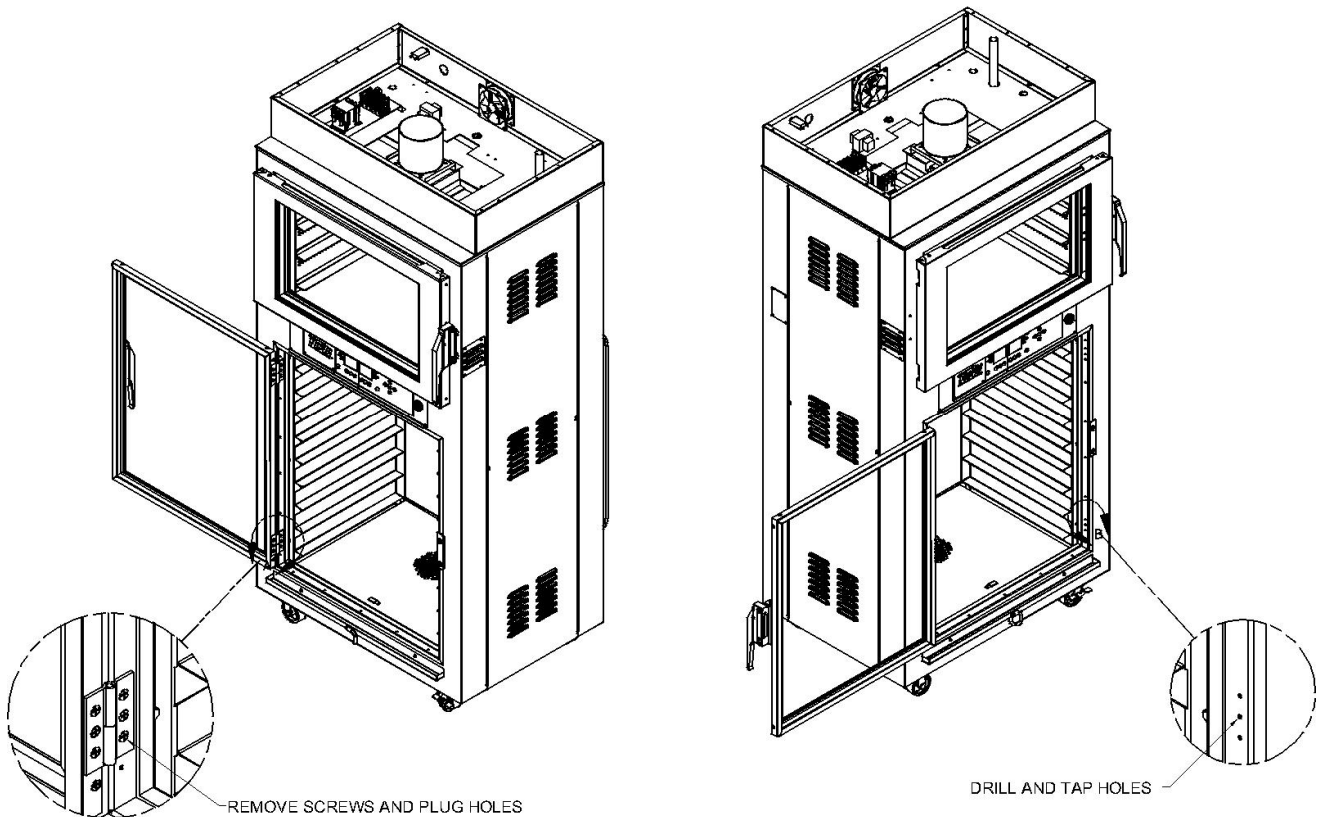

Drawing 6

1. Remove doors, hinges, and strike from the proofer.
2. Install steel plugs in all existing hinge and handle holes.
3. Locate the new hinge holes on the proofer. $\varnothing.136$ holes are punched in the jamb to locate where the holes should be drilled.
4. Drill out each hole with a #30 drill bit. Follow with a 5/32" bit. Tap 10-32.
5. Install new hinges and strike plate.
6. Hang door and make needed adjustments on strike plate.

Tools required:

Phillips screwdriver

3/8" wrench

Reversible drill (corded or cordless)

#30 drill bit (can be ordered from Nu-Vu, P/N 51-0624)

5/32" drill bit (can be ordered from Nu-Vu, P/N 51-0194)

10-32 tap (can be ordered from Nu-Vu, P/N 51-0296)

Parts required:

Hinges (2 required)

11/64" Hole plugs (8 required), Nu-Vu P/N 53-0233

CALIBRATION INSTRUCTIONS

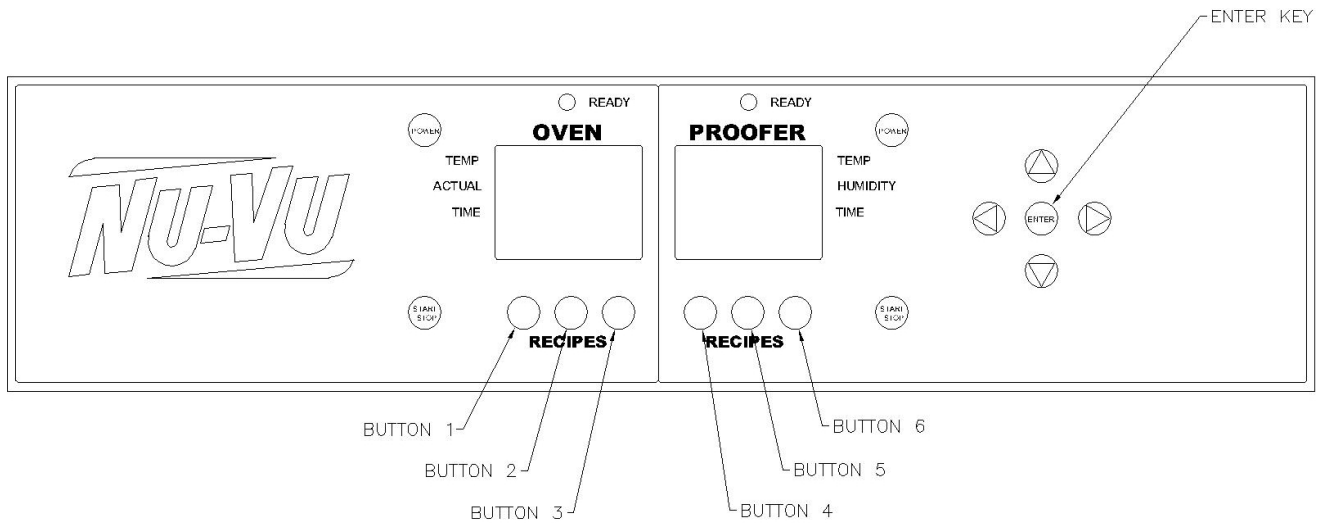

Drawing 7

- 1) Place a thermocouple or a reliable thermometer on a pan in the center of each cavity.
- 2) Turn on the oven and proofer cavities of the unit by pressing the buttons labeled power
- 3) Allow the temperature in the oven and proofer to stabilize.

Important Note: Allow the oven to cycle at least twice before attempting to calibrate the unit.

- 4) Note the maximum temperature readings of the thermocouple or thermometer and the corresponding temperature display.
- 5) Subtract the maximum temperature of the display from the maximum value of the thermocouple or thermometer. For example; the maximum temperature on the display was 356 and the maximum temperature of the thermocouple or thermometer was 351. ($351 - 356 = -5$) The offset for the oven would be negative five.
- 6) Press and hold the enter key for approximately 15 seconds until a beep is heard.
- 7) The offset screen will now be displayed. The recipe buttons (labeled button 1 – button 6 in the above drawing). Button 1 will decrease the humidity offset by one, button 4 will increase the humidity offset by one. Button 2 will decrease the proofer temperature offset by one, button 5 will increase the proofer temperature offset by one. Button 3 will decrease the oven temperature offset by one, button 6 will increase the oven temperature offset by one. Using the above example; press button 3 five times.
- 8) After entering the desired offsets press the enter key to exit the offset screen.
- 9) Allow the temperature to cycle again and observe the maximum temperature as describe in step 4. If the temperatures are the same the unit is properly calibrated and ready for use. If the temperatures are not the same, repeat the calibration process beginning with step 4.

REPLACEMENT PARTS LIST

(SUB-123P)

Reference #	Description	Replacement Part #
ELECTRICAL COMPONENTS - -		
1	Power Terminal Block	50-0237
2	Ground Lug	50-1329
3	Contactor:	
	120-volt coil, 40-amp (US).....	66-2013
4	Programmable Controller Assembly	112-9153
5	Oven Temperature Sensor	252-3001
6	Oven Heating Element:	
	208-volt, 2000-watt	251-1005
	240-volt, 2000-watt	251-1002
7	Oven Motor Assembly.....	250-1002
8	Proofer Sensor	66-1146
9	Proofer Heat Element:	
	120-volt, 255-watt (Manual Fill).....	60-0002-B
	120-volt 600-watt (Automist).....	60-0001-1-B
10	Proofer Humidity Element Assembly:	
	120-volt, 650-watt (US)	251-2001
11	Proofer Motor Assembly:	
	Manual Fill.....	250-2004
	Automist.	250-2010
12	Control Transformer (24 VAC output)	66-9505
15	Oven Door Micro Switch	252-2004
16	Alarm	252-1022
17	Thermal Overload Safety (425°F).....	66-1114
18	Manual Reset Fuse (20 Amp).....	66-1097
19	Cooling Fan.....	250-3001
20	Light Fixture:	
	Socket	50-1020
	Bulb:	
	120-volt, 40-watt (US)	50-0695
	Light fixture kit Oven (Socket, Globe, and Gasket)	252-7004
	Light fixture kit Proofer (Socket, Globe, and Gasket)	252-7006
21	Water Solenoid Valve (Automist only).....	50-0308-1
DOOR COMPONENTS - -		
41	Oven Door (without Latch):	
	Hinged Left	112-9159
	Hinged Right	112-9151
42	Proofer Door (without hardware).....	21-1950
43	Proofer Door Hinge:	
	Left side	254-3011
	Right side	254-3012
44	Latch/Catch Assembly:	
	Proofer.....	254-2025
	Oven	254-2026
46	Gasket:	
	Oven Door.....	254-1001
	Proofer Door	70-0358-A

OVEN INTERIOR COMPONENTS - -

50	Oven Wall Assembly (Right).....	112-9067
51	Oven Wall Assembly (Left).....	112-9066
52	Oven Element / Fan Cover.....	112-0013-B
53	Wire Fan Guard.....	112-0275

PROOFER INTERIOR COMPONENTS - -

60	Proofer Element / Fan Cover	
	Manual Fill	112-0031-1-A
	Automist	112-9027
61	Proofer Wall Assembly (Right)	112-9023
62	Proofer Wall Assembly (Left)	112-9024
64	Water Pan (Manual Fill only)	50-0074
65	Wire Shelf	112-0059-B
67	Quick Change Nozzle Kit	251-3005
67a	Quick Change Nozzle.....	31-0454
67b	Quick Change Nozzle Base.....	31-0453

GENERAL EXTERIOR COMPONENTS - -

71	Outside Top.....	112-0075-B
75	Caster	50-0058
76	Water Inlet Bulkhead (Automist only)	31-0058
77	Drain Pan	50-0547
78	Side Panel	112-0066-1-A
79	Water Filter Assembly (Automist only)	112-9166
81	Drip Trough Assembly.....	135-9950

AMP/TYCO ELECTRONICS
 P/N 1-480710-0
 Universal MATE-N-LOK

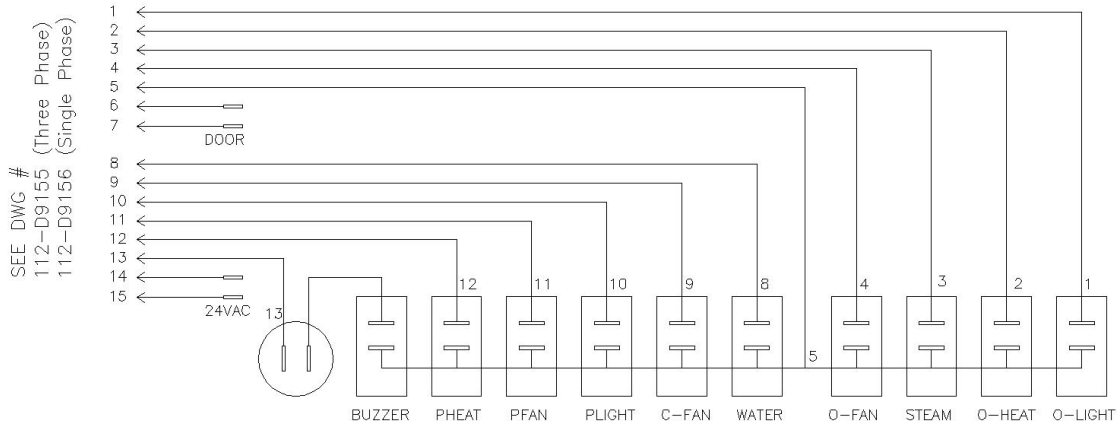

NUVU Food Service Systems 5600 13th STREET MENOMINEE, MICHIGAN 49855	REV.	DESCRIPTION	CHANGED BY	DRAWN BY: KM	VOLTAGE: 208-240	MODEL #: SUB-123
	A.3	ADDED PANEL MOUNT	KM	CHECKED:	PHASE: SINGLE or THREE	CUSTOMER
		BUZZER	DATE	DATE: 01-31-2008	WATTAGE:	
			6-4-2008	BOM FILE #	CONTROLS: PROGRAMABLE	DWG. NO. 112-D9154

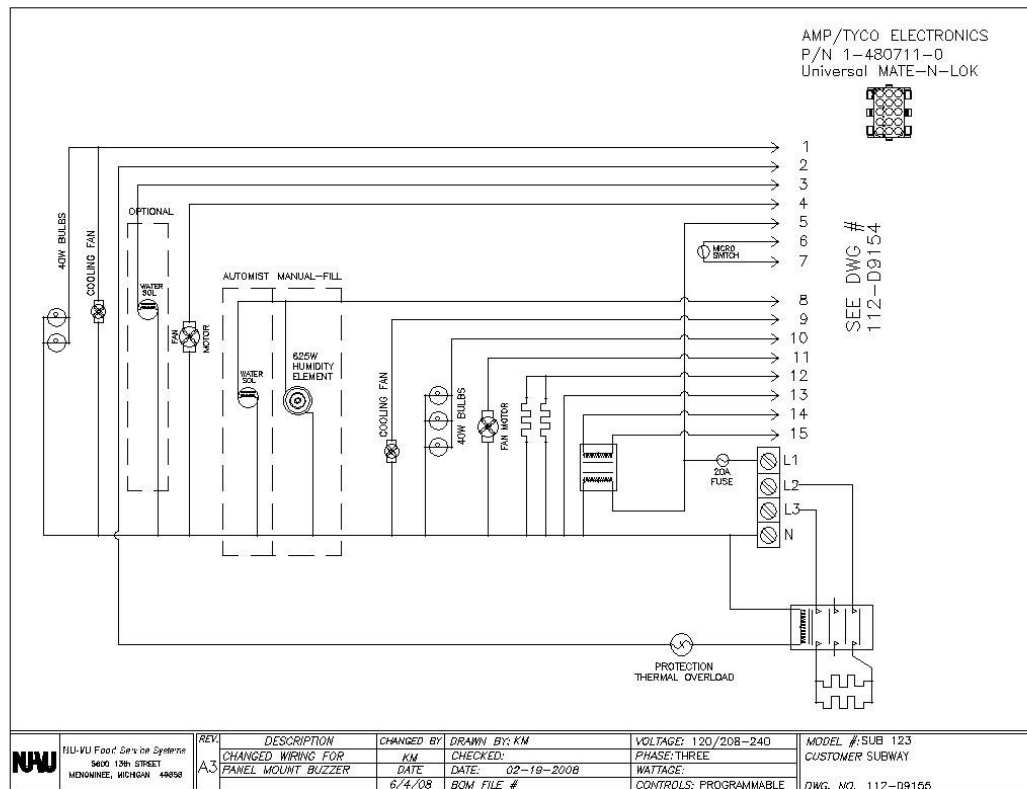
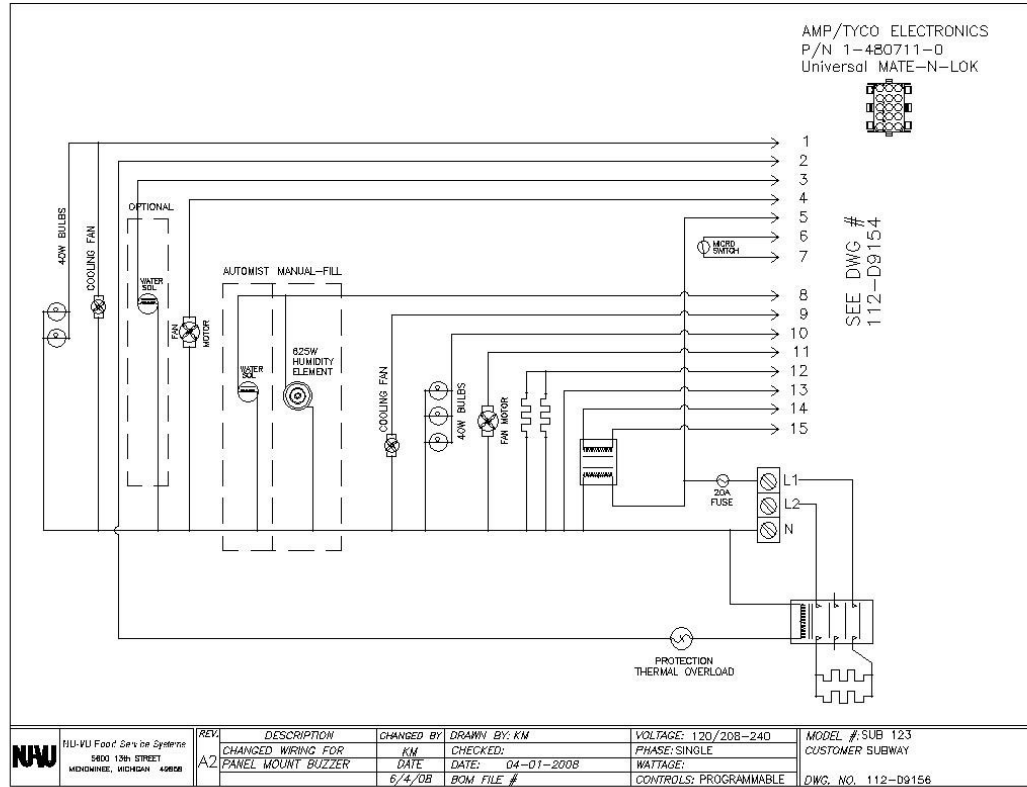

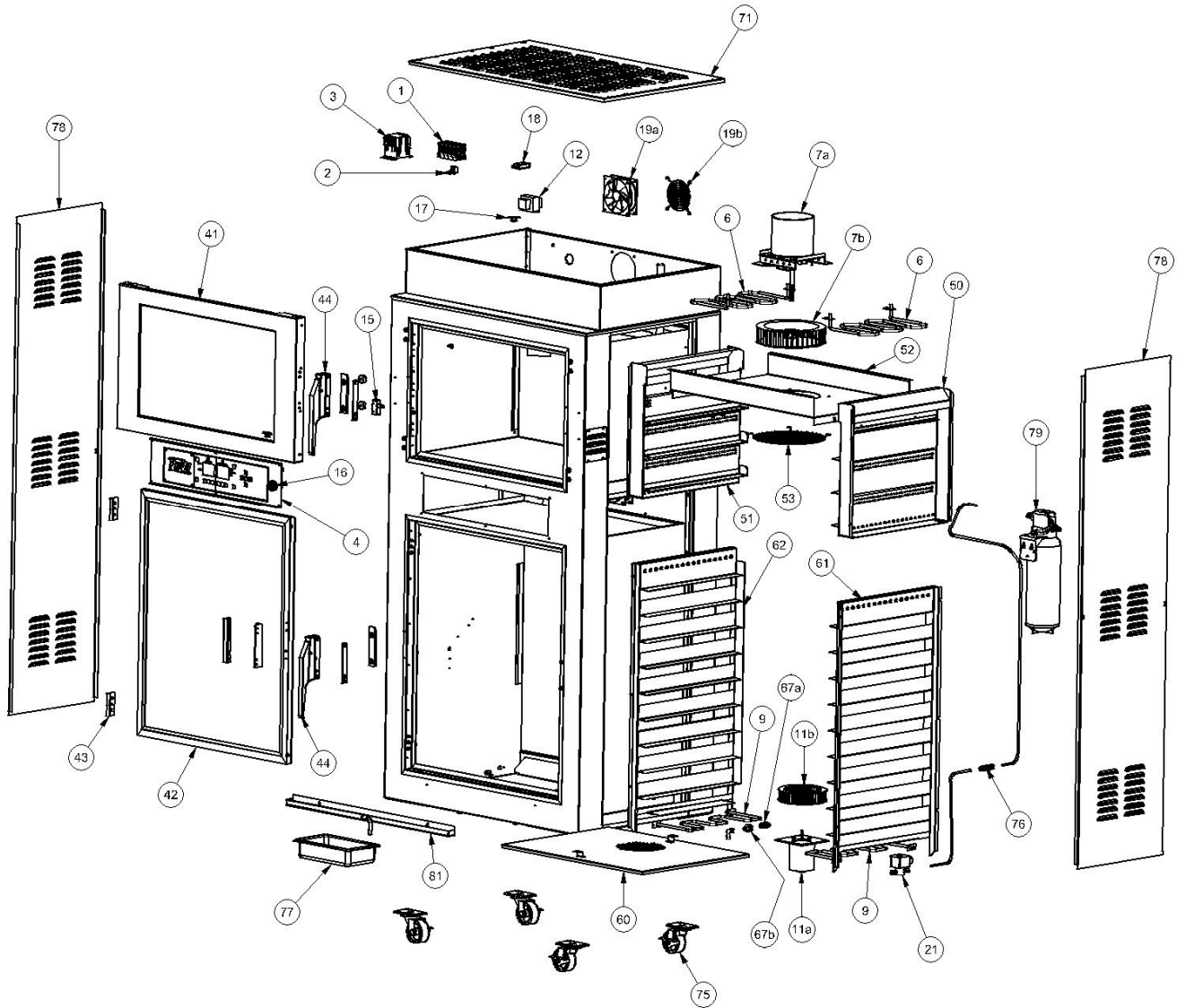

Replacement Parts List		
Reference #	Description	Replacement part #
1	Power Terminal Block	50-0237
2	Ground Lug	50-1329
3	Contactors (120V coil)	66-2013
4	Programmable Control Assembly	112-9153
5*	Oven Temperature Sensor	252-3001
6	Oven Heating Element (208V)	251-1005
6	Oven Heating Element (240V)	251-1002
7	Oven Motor Assembly	250-1002
7a	Oven Motor	66-5504
7b	Blower Wheel	50-0444
8*	Proofer Sensor	66-1146
9	Proofer Heat Element (120V)	60-0001-1-B
11	Proofer Motor Assembly	250-2010
11a	Proofer Motor	66-5503
11b	Blower Wheel	50-0362
12	Control Transformer	66-9505
15	Oven Door Switch	252-2004
16	Alarm (included w/ Programmable Control Assembly)	252-1022
17	Hi Limit Switch	66-1114
18	Manual Reset Fuse (20A)	66-1097
19	Cooling Fan Assembly (120V)	250-3001
19a	Cooling Fan	50-0049
19b	Fan Guard	50-0048
20	Oven Light Fixture Kit (Socket, Globe, and Gasket)	252-7004
20	Proofer Light Fixture Kit (Socket, Globe, and Gasket)	252-7006
21	Water Solenoid Valve (120V)	50-0308-1
41	Oven Door Assembly (without Latch), Left Hinged	112-9151
41*	Oven Door Assembly (without Latch), Right Hinged	112-9159

Replacement Parts List		
Reference #	Description	Replacement part #
41*	Oven Door Assembly (without Latch), Right Hinged	112-9159
42	Proofer Door Assembly (without Hardware)	21-1950
43	Proofer Door Hinge (Left Hinged Unit)	254-3011
43*	Proofer Door Hinge (Right Hinged Unit)	254-3012
44	Latch / Catch Assembly (Proofer)	254-2025
44	Latch / Catch Assembly (Oven)	254-2026
46	Oven Door Gasket (included with Oven Door Assembly)	254-1001
46	Proofer Door Gasket (included with Proofer Door Assembly)	70-0358-A
50	Oven Wall Assembly (Right)	112-6067
51	Oven Wall Assembly (Left)	112-9066
52	Oven Element / Fan Cover	112-0013-B
53	Wire Fan Guard	112-0275
60	Proofer Element / Fan Cover (Automist)	112-9027
61	Proofer Wall Assembly (Right)	112-9023
62	Proofer Wall Assembly (Left)	112-9024
65*	Wire Shelf	112-0059-B
67	Quick Change Nozzle Kit	251-3005
67a	Quick Change Nozzle (includes strainer)	31-0454
67b	Quick Change Nozzle Base	31-0453
71	Outside Top	112-0075-B
75	Caster	50-0058
76	Water Inlet Bulkhead	31-0058
77	Drain Pan	50-0547
78	Side Panel	112-0066-1-A
79	Water Filter Assembly	112-9166
81	Drip Trough Assembly	135-9950

* indicates part is not shown

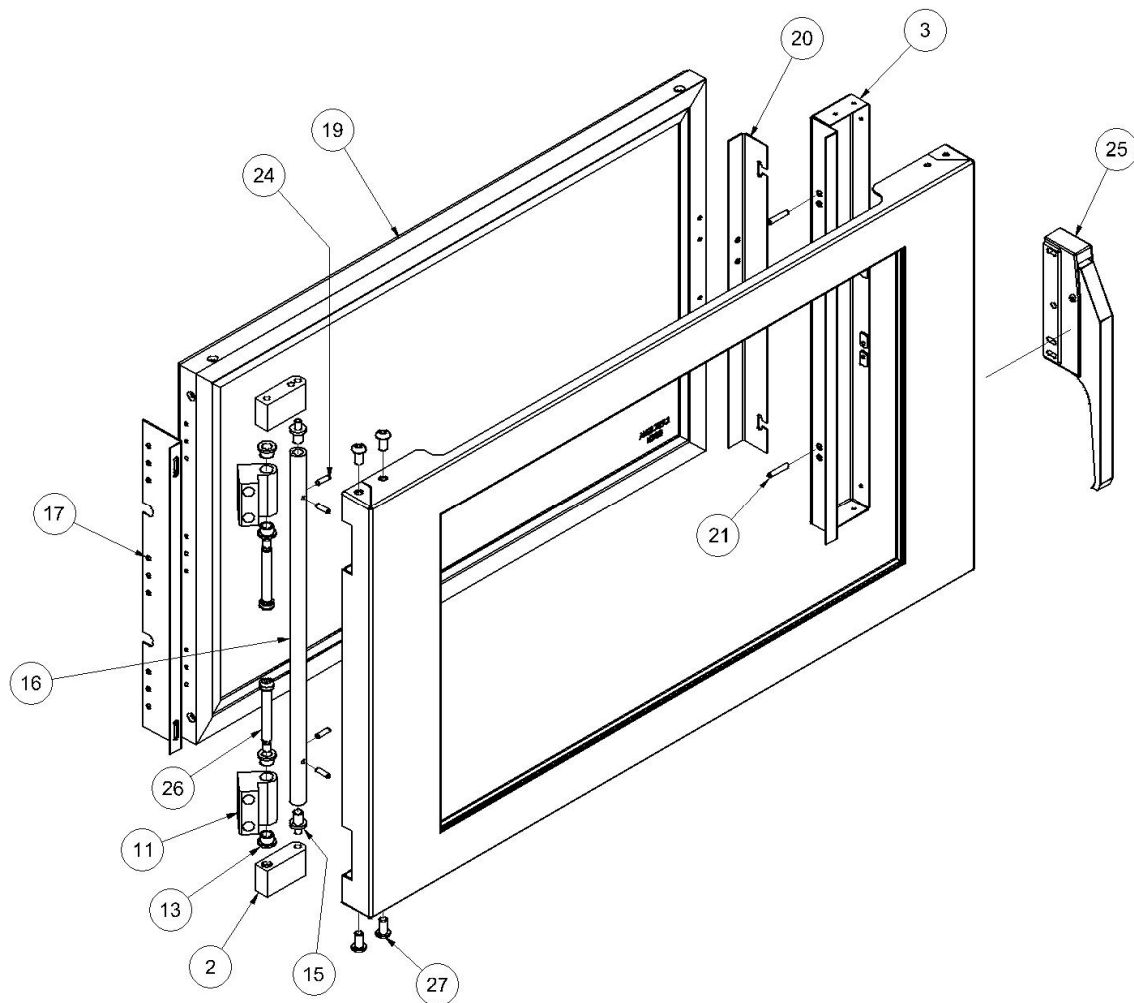

Parts List

ITEM	QTY	PART NUMBER	DESCRIPTION
2	2	07-0113	BLOCK,HINGE,OVEN
3	1	112-9167	WLDMT,COVER,LATCH
11	2	07-0084	HINGE,HIDDEN
13	4	50-1358	BUSHING
15	2	07-0114	HINGE PIN
16	1	112-0299	HINGE
17	1	112-0301	HINGE,DOOR,INNER
19	1	112-9158	ASSY,DOOR,OVEN,INNER
20	1	112-0302	LATCH,DOOR,INNER
21	2	2002313	PIN
24	4	112-0305	PIN,.187X5/8,10-32
25	1	50-1346	LATCH,HANDLE,OFFSET
26	2	53-0313	Hexagon Socket Shoulder Screw
27	4	53-0314	Hexagon Socket Button Head Cap Screw