



Grand Rapids, Michigan, U.S.A. 49504-5298

USER'S OPERATING AND INSTRUCTION MANUAL

MODEL 777-N

VARIETY SLICER

INDEX

<u>Section Description</u>	<u>Document No.</u>	<u>Page No.</u>
SAFETY INSTRUCTIONS -----	0777S20008 -----	1-1
DESCRIPTION/SPECIFICATIONS -----	0777S20009 -----	2-1
Description -----		2-1
Specifications -----		2-1
INSTALLATION INSTRUCTIONS -----	0777S20010 -----	3-1
Removing the Slicer from the Shipping Platform -----		3-1
Installing the Rubber Feet -----		3-2
Installing Optional Casters -----		3-2
OPERATING INSTRUCTIONS -----	0777S20011 -----	4-1
TROUBLESHOOTING -----	0777S20012 -----	5-1
The Slicer Will Not Start (Motor is Not Humming) -----		5-1
The Slicer Will Not Start (Motor is Humming) -----		5-2
The Slicer Starts Without Pulling the Knob -----		5-2
The Slicer Does Not Stop When Slicing is Complete -----		5-2
The Slicer Stops Before Slicing Starts or is Complete -----		5-2
Bread Slices Vary in Thickness -----		5-2
The Blade Frames are Knocking -----		5-3
MAINTENANCE -----	0777S20013 -----	6-1
Cleaning -----		6-1
Lubrication -----		6-1
Removing the Blade Frames -----		6-1
Replacing the Blade Frames -----		6-4
Changing the Blades -----		6-5
Tightening the Belt -----		6-7
Replacing the Belt -----		6-8
Adjusting the Blade Frames When Slices Vary in Thickness -----		6-9
Adjusting the Clearance Between the Blade Frames -----		6-9
RECOMMENDED SPARE PARTS -----	0777S20014 -----	7-1
<u>REPLACEMENT PARTS SECTION</u>		
ASSEMBLY DRAWING (MECHANICAL PARTS) -----	0777S20015 -----	8-1
REPLACEMENT PARTS (MECHANICAL) -----	0777S20016 -----	9-1

Continued

INDEX (Continued)

<u>Section Description</u>	<u>Document No.</u>	<u>Page No.</u>
ELECTRICAL SINGLE PHASE -----	0777S20017 -----	10-1
Wiring Diagram (Single Phase) -----		10-1
Assembly Drawing (Single Phase) -----		10-1
Parts List 1/2 HP, 115 VAC, 60 Hertz, 1 Phase -----		10-2
Parts List 1/2 HP, 230 VAC, 60 Hertz, 1 Phase -----		10-2
Parts List 1/2 HP, 220 VAC, 50 Hertz, 1 Phase -----		10-2
WARRANTY -----	GEN 040225	
WARRANTY PROCEDURE -----	GEN 040226	
RETURNED PARTS POLICY -----	GEN 040227	

SAFETY INSTRUCTIONS

WARNING

VARIOUS SAFETY DEVICES AND METHODS OF GUARDING HAVE BEEN PROVIDED ON THIS MACHINE. IT IS ESSENTIAL HOWEVER THAT THE MACHINE OPERATORS AND MAINTENANCE PERSONNEL OBSERVE THE FOLLOWING SAFETY PRECAUTIONS. IMPROPER INSTALLATION, MAINTENANCE, OR OPERATION OF THIS EQUIPMENT COULD CAUSE SERIOUS INJURY OR DEATH.

1. Read this manual before attempting to operate your machine. Never allow an untrained person to operate or service this machine.
2. Connect the machine to a properly grounded electrical supply that matches the requirements shown on the electrical specification plate and follow all specifications of local electrical codes.
3. Disconnect and lock-out the machine from the power supply before cleaning or servicing.
4. Check and secure all guards before starting the machine.
5. Observe all caution and warning labels affixed to the machine.
6. Use only proper replacement parts.
7. Do not wear loose fitting clothing or loose hair when working near this machine. Shirt tails should be tucked in.
8. Wear proper, personal, protective, safety equipment.
9. Keep Hands away form the moving parts of this machine while it is in operation.
10. In addition to these general safety instructions, also follow the more specific safety instructions given for the different areas of the machine operating instruction manual.

WARNING

DO NOT USE FOR OTHER THAN ORIGINALLY INTENDED PURPOSE.

DESCRIPTION/SPECIFICATIONS

Description

The Oliver Variety Slicer is a compact, sturdy, time tested design, which has been used in bakeries world wide for many years. It is easy to operate and allows the slicing of virtually all varieties of bread, quickly and cleanly, with a spring fed pusher that gently moves the product through the knives followed by a automatic shut off. Its design will provide years of efficient, trouble-free operation requiring a minimum of maintenance.

The Variety Slicer is of stainless steel, plated, and painted construction for easy cleaning and maintenance. The knives can be replaced, by most operators, without the need of a service call.

The Variety Slicer is backed by Oliver Products Company, who has a reputation of serving the Baking Industry for well over 60 years.

Specifications

Space Requirements: (All Dimensions are Approximate)

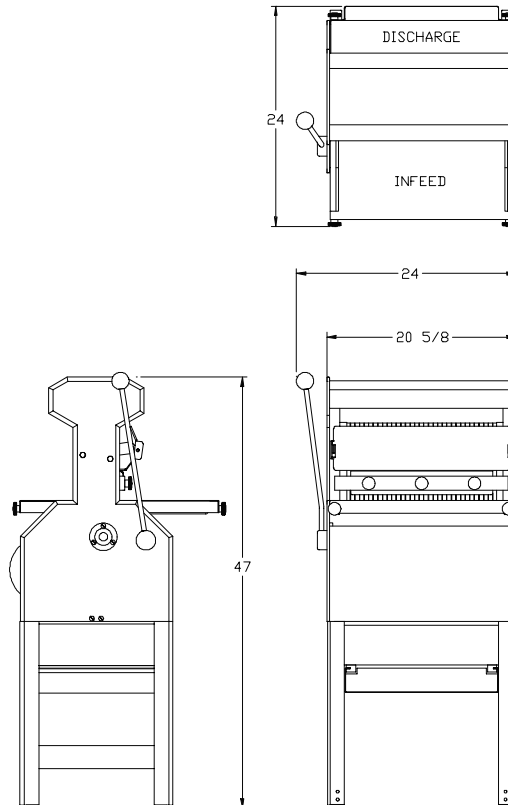

Product Capacities:

Up to 16" long, 10-1/2" wide and from 3-1/2 to 6" high.

Electrical Options Available:

1 phase, 60 hz, 115VAC, 7 Amps.
1 phase, 60 hz, 230VAC, 3.5 Amps.

Others Available consult factory.

Standard Slice Spacings

7/16, 1/2, 9/16

Optional Slice Spacings (At additional cost)

1/4, 5/16, 3/8, 5/8, 3/4, 7/8, 1"

Others Available consult factory.

Shipping Weight

250 lbs. (Floor Model)

INSTALLATION INSTRUCTIONS

CAUTION

**THE SLICER IS HEAVY, USE PROPER TECHNIQUE WHEN LIFTING.
KEEP BACK STRAIGHT, KNEES BENT, AND LIFT WITH LEGS.
USE GLOVES TO PROTECT HANDS.**

Removing the Slicer from the Shipping Platform

Lift the slicer off the shipping platform with one person on each side of the slicer. Set the slicer down on a level floor.

Using the shipping platform or other blocks, carefully lower the slicer to its side as shown below.

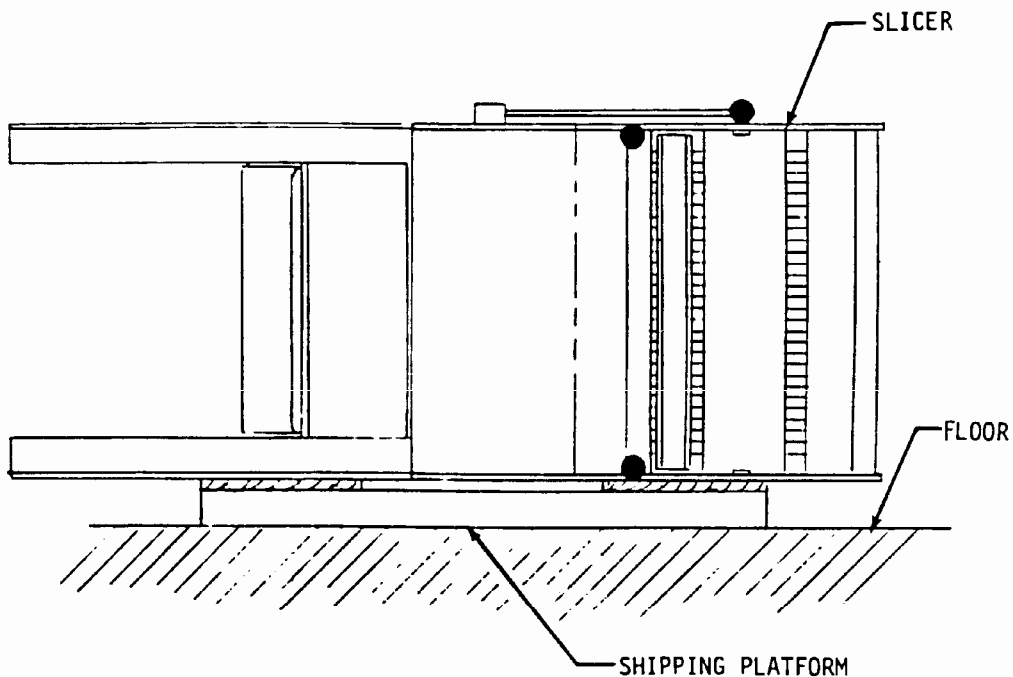

NOTE

**PERFORM THE FOLLOWING DEPENDING ON WHICH OPTIONS
HAVE BEEN ORDERED WITH THE MACHINE.**

Installing the Rubber Feet

Remove the rubber feet from the accessory package and insert the plugs into the holes in the leg bottoms, see below. Carefully restore the machine to the upright position.

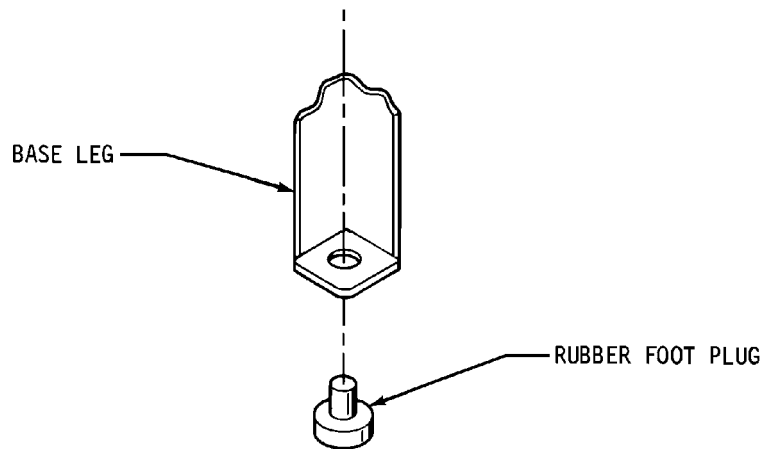

Installing Optional Casters

Remove the casters, caster brackets and hardware from the accessory package. Insert the studs of the brackets, see figure below, through the holes provided on the base of the slicer. Secure the brackets with the lock washers and hex acorn nuts. Press fit the casters into the brackets as shown below. Carefully restore the machine to the upright position.

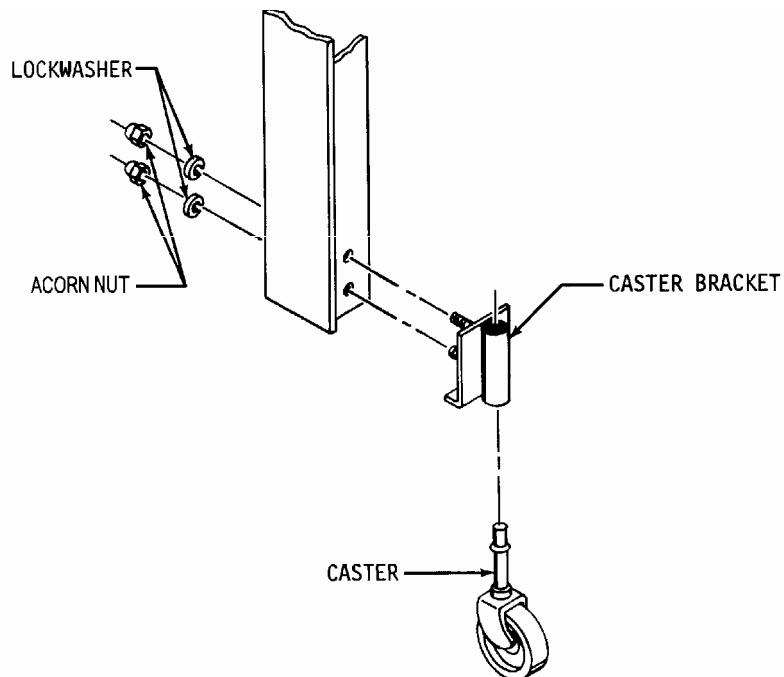

OPERATING INSTRUCTIONS

CAUTION

ALWAYS USE CARE WHENEVER WORKING NEAR THE CUTTING KNIVES.

To operate the slicer, stand on the discharge side, grasp the lever with the right hand, see below, pull it down as far as it will go and hold it there. With the left hand place the loaf of bread in front of the pusher.

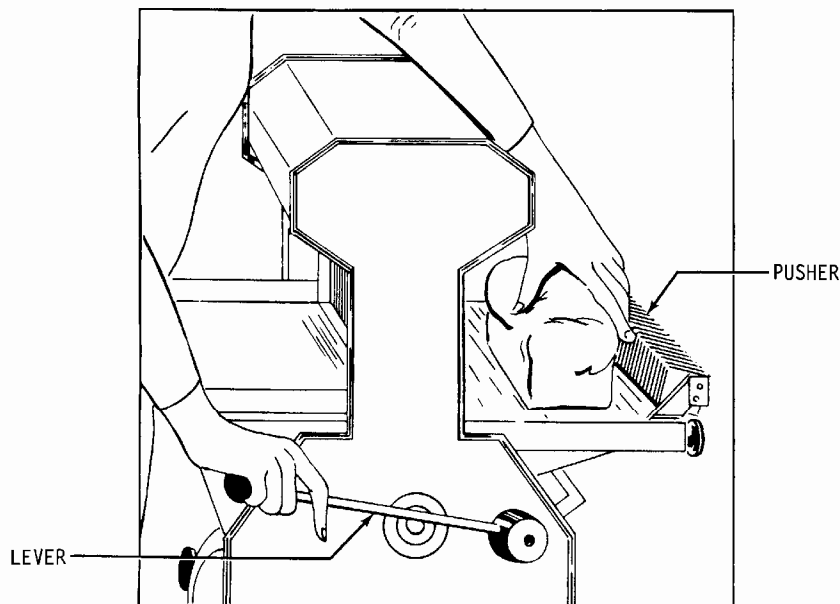

While continuing to hold the lever down with the right hand move the left hand to the discharge side of the machine and pull the motor starting knob, see next illustration. Allow the right hand to raise slowly with the lever until the loaf contacts the slicer blades. After the knives have pierced the crust remove your right hand from the lever allowing the pusher to move the loaf through the knives.

CAUTION

**NEVER PUSH THE HAND LEVER.
DOING SO MAY RESULT IN DAMAGE TO THE MACHINE'S COMPONENTS.**

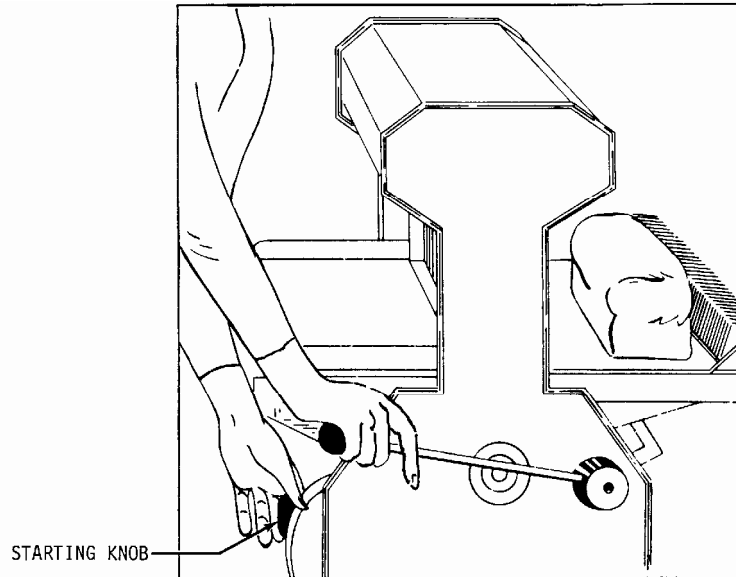

CAUTION

**THE KNIVES ARE EXTREMELY SHARP.
DO NOT TOUCH MOVING OR STATIONARY KNIVES.**

The motor and slicer knives will stop automatically when the pusher comes to its full forward position. Remove the loaf from the table and bag or wrap the product. Use the same procedure for each loaf.

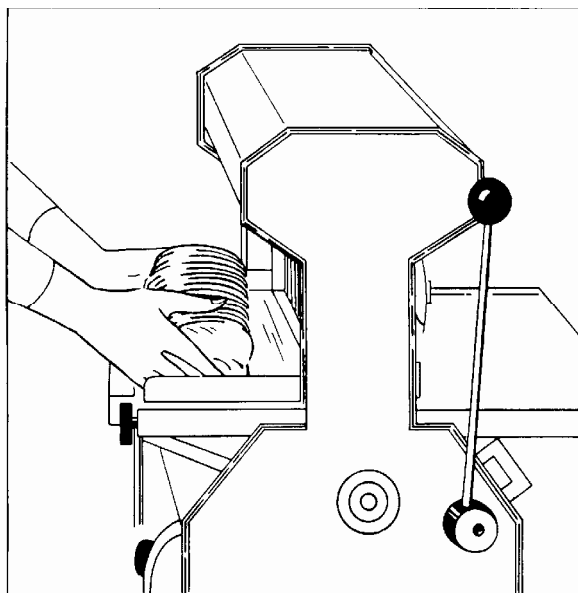

TROUBLESHOOTING

WARNING

ALWAYS DISCONNECT THE SLICER FROM THE POWER SUPPLY BEFORE ATTEMPTING ANY TYPE OF MAINTENANCE TASK, INCLUDING TROUBLESHOOTING.

The Slicer Will Not Start (Motor Is Not Humming)

- The machine is not plugged in.
- There is no power at the outlet. (Check by plugging in a small working appliance, like a lamp. Check to see if a circuit breaker has tripped. If the circuit breaker has not tripped and the circuit is still not working have a qualified electrician check the circuit.)
- The motor switch overload has tripped. (To reset push firmly in the direction shown on the switch nameplate.)
- There are bread crumbs in the motor starting switch. (Have a qualified electrician disassemble the switch and clean it.)
- The switch arm on the Switch Trip Mechanism is bent. (A qualified service agent can bend the arm to correct the problem, see the illustration below.)

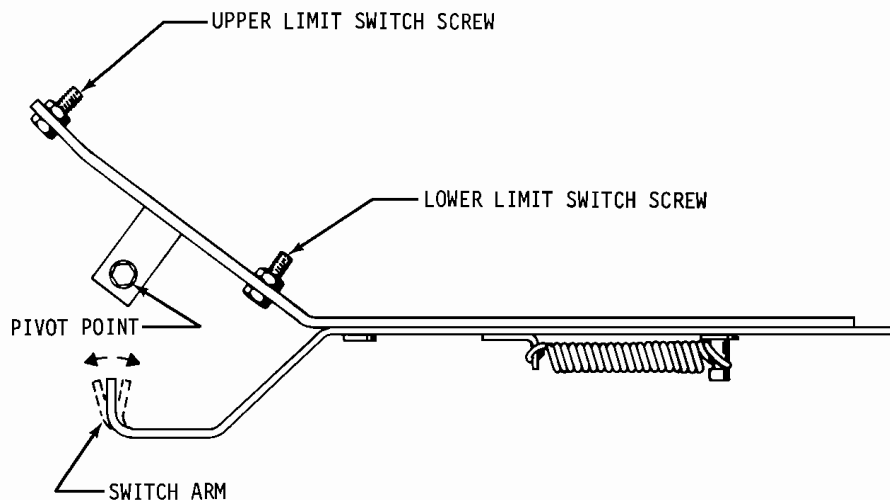

- The switch trip mechanism is binding. (Clean the mechanism and lubricate its pivot point, see above illustration.)
- The upper limit switch is not being made. (Adjust the limit switch screws as required to correct the problem, see above illustration.)

The Slicer Will Not Start (Motor Is Humming)

CAUTION

**DO NOT ALLOW THE MOTOR TO HUM WITHOUT STARTING.
THE MOTOR CAN BE PERMANENTLY DAMAGED BY OVERHEATING.**

- The motor has failed. (Have it checked by a qualified electrician.)

NOTE

A SPECIAL NON-VENTILATED MOTOR MUST BE USED WITH THIS SLICER.

- The drive system is binding. (Have a qualified service agent check for defective bearings or other restrictions to free movement.)
- There is mechanical interference between other parts of the slicer. (Have a qualified service agent evaluate the machine for adjustment or replacement of defective parts.)

The Slicer Starts Without Pulling the Knob

- The switch arm on the Switch Trip Mechanism is bent. (A qualified service agent can bend the arm to correct the problem, see the illustration in the “The Slicer Will Not Start” section above.)

The Slicer Does Not Stop When Slicing is Complete

- Either one or both of the upper and lower limit switch screws on the limit switch trip mechanism are out of adjustment. (Adjust the limit switch screws as required to correct the problem, see the illustration in the “The Slicer Will Not Start”, section above.)

The Slicer Stops Before Slicing Starts or is Complete

- The lower limit switch screw on the limit switch trip mechanism is out of adjustment. (Adjust the screw as required to correct the problem, see the illustration in the “The Slicer Will Not Start”, section above.)
- The switch trip mechanism is binding. (Clean the mechanism and lubricate its pivot point, see the illustration in the “The Slicer Will Not Start”, section above.)

Bread Slices Vary in Thickness

- The blade frames are out of adjustment. (See the “Maintenance” section of this manual under “Adjusting the Blade Frames When Slices Vary in Thickness” on how to perform this adjustment.)

The Blade Frames Are Knocking

- The blade frames are out of adjustment. (See the “Maintenance” section of this manual under “Adjusting the Clearance Between the Blade Frames” on how to perform this adjustment.)

MAINTENANCE

WARNING

ALWAYS DISCONNECT THE SLICER FROM THE POWER SUPPLY BEFORE ATTEMPTING ANY TYPE OF MAINTENANCE TASK.

Cleaning

Use a mild detergent solution to clean all exterior surfaces and empty the crumb tray daily or more often if necessary. Periodically remove both tables and the crumb chute and then brush, blow, (if compressed air is available), or wipe all foreign material from all surfaces, especially from moving parts.

Lubrication

Once a month, more often during heavy use, put a drop of food approved lubricant on each of the pivot points of the plastic links at the top to the blade frames. Also add a drop or two of the same food approved lubricant to the switch trip mechanism pivot point, pusher lever and yoke pivots. All other bearings are either grease packed or sealed and seldom need attention.

NOTE

NEVER OIL OR GREASE THE MOTOR.

Removing the Blade Frames

To remove the blade frames you must first remove the infeed table, crumb chute, and discharge table. First remove the four black knobs securing the tables, (see the illustration below). In addition to the knobs the infeed and discharge tables are held in place by friction so pull the infeed table straight out and hard to separate them.

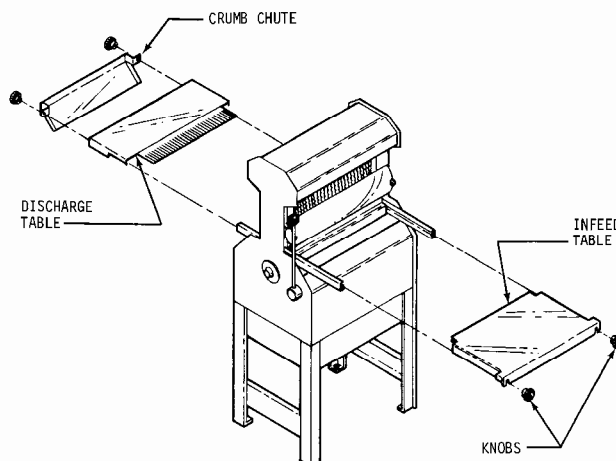

Removing the Blade Frames (Continued)

Always start by removing the discharge side blade frame first. Both blade frames should be removed from the discharge side of the machine. You should remove the discharge side blade frame completely from the machine before starting on the infeed side blade frame. However each is removed using similar procedures.

NOTE

NEVER LOOSEN THE NUTS ON THE ECCENTRIC PINS OR ATTEMPT TO REMOVE THEM TO AID IN REMOVING THE BLADE FRAMES.

Start by pulling the hairpin clip from the eccentric pin, located at the top of each blade frame, see illustration below, then slide the top link toward the lever side of the slicer. Make sure that the link is forced all the way over to the cross member.

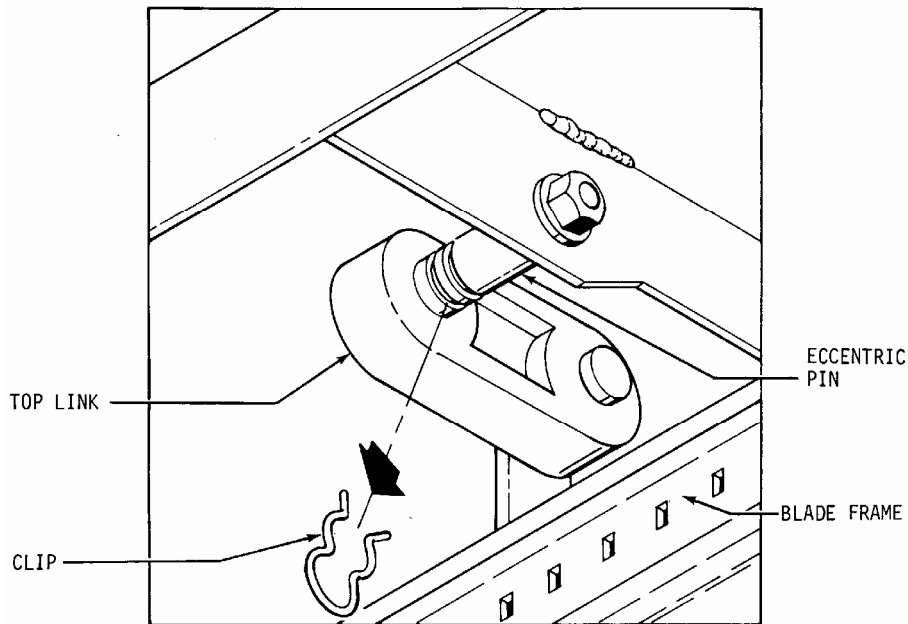

Next remove the two locking cams, eye bolts, with Belleville washers, from the bottom of the blade frame, they secure the frame to the rocker's swing shaft. The eye bolts can be removed by turning them counter clockwise once the cams have been removed. See the next illustration.

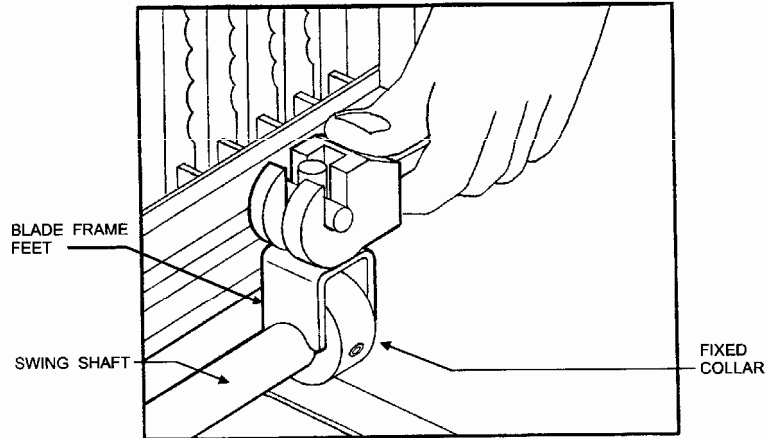

CAUTION

**THE BLADES ARE EXTREMELY SHARP.
ALWAYS HANDLE BLADE FRAMES WITH CARE.**

The blade frame can now be carefully lifted from the slicer. See below. The remaining blade frame can be removed in the same manner.

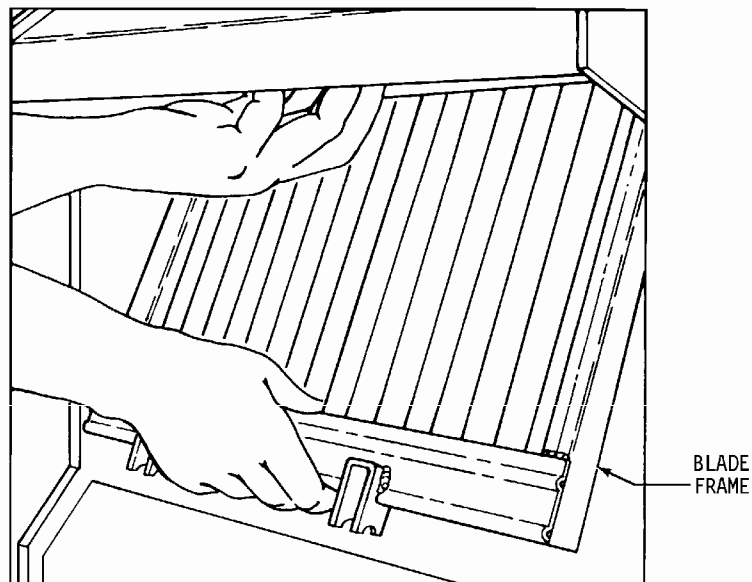

Replacing the Blade Frames

Replacement of the blade frames is done by reversing the removal procedures. Ensure That the feet of the blade frames rest snugly on the swing shafts and that you have included the belleville washers with the eye bolts.

NOTE

WHEN INSTALLING THE BELLEVILLE WASHERS, THEY MUST BE PLACED SO THAT THE CROWN IS UP AS SHOWN IN THE ILLUSTRATION BELOW.

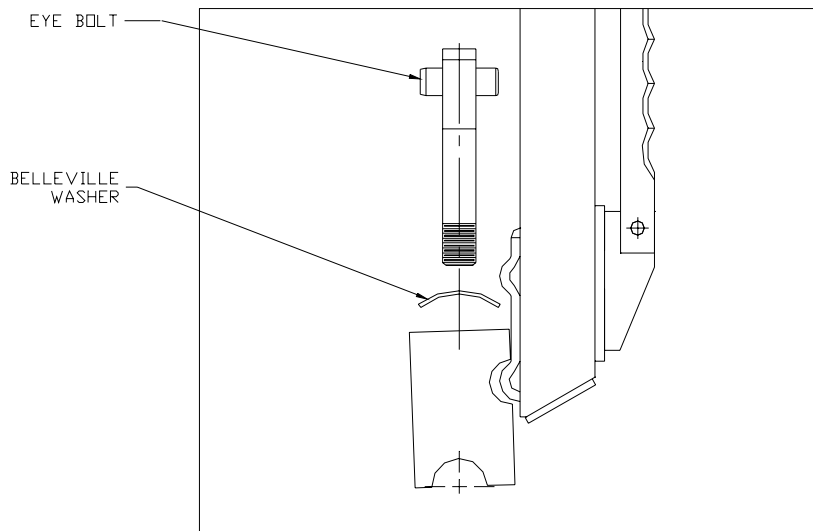

When replacing the eye bolts turn them clockwise until moderate pressure is required to close the cam. If the cam is too easy to close rotate the eye bolt a half turn more in the clockwise direction and try to reinstall the cam. Repeat these partial rotations until moderate pressure is required to close the cam. If the cams are either difficult or impossible to close, rotate the eye bolt a half turn in the counter clockwise direction. Repeat until the cams can be closed using moderate pressure.

Changing the Blades

CAUTION

THE BLADES ARE EXTREMELY SHARP. ALWAYS HANDLE THEM WITH CARE.

NOTE

DO NOT INTERCHANGE THE TWO BLADE FRAMES. REPLACE THE BLADE FRAME TO THE SAME SIDE OF THE MACHINE AS IT WAS TAKEN FROM

NOTE

WHEN CHANGING BLADES FIRST NOTE THE DIRECTION THE SHARPENED EDGES ARE FACING ON THE BLADE FRAME. THEY ARE FACING UP ON ONE FRAME AND DOWN ON THE OTHER. DO NOT CHANGE THIS DIRECTION.

Place the blade frame on a flat surface. You may use the special knife tool, shown in the illustration below, or use a common set of pliers to depress the spring-loaded pin holding each knife. This will reduce the tension on the knife so that it may be easily removed.

In the illustration below you can see the use of the knife tool. It is inserted into the blade frame on the spring-loaded pin end and then by lifting up on the tool it will deflect the upper spring-loaded pin reducing the tension on the knife. Once this has been done the knife can be carefully removed.

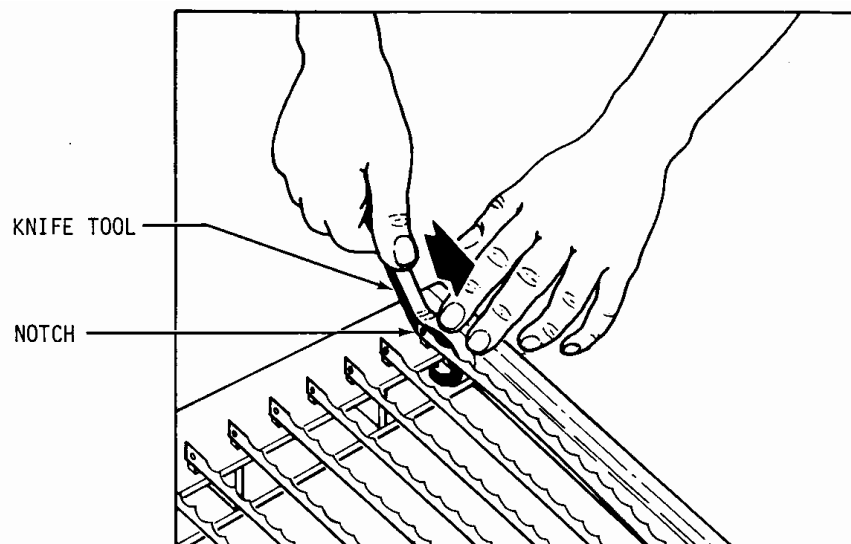

Rev. 2/15/05

Changing the Blades (Continued)

The new knife can be installed by reversing the removal procedure. A paper clip can be used to hold the knife in position on the lower pin to ease installation. See the illustration below.

NOTE

WHEN REPLACING ALL THE KNIVES, ALWAYS REMOVE THE CENTER KNIVES FIRST AND WORK TOWARD THE ENDS. INSTALL THE NEW KNIVES AT THE ENDS FIRST AND WORK ALTERNATELY TOWARD THE CENTER.

CAUTION

NEVER PUT BLADE FRAMES IN THE SLICER WITHOUT KNIVES.

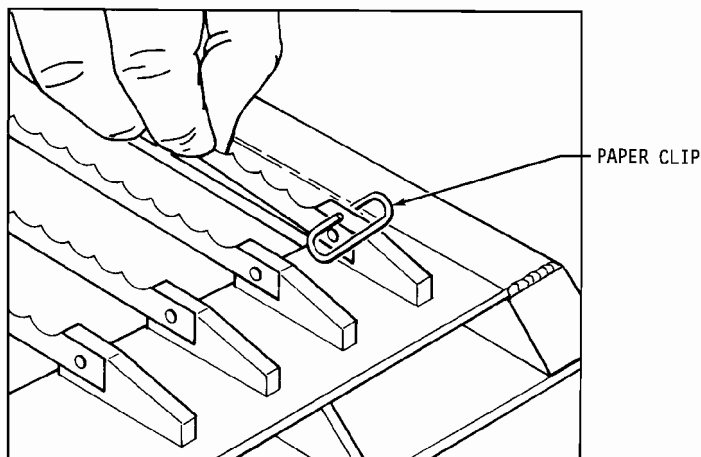

Tightening the Belt

CAUTION

**OVER-TIGHTENING THE DRIVE BELT
MAY CAUSE BEARING OR MOTOR FAILURE.**

Remove the crumb tray from the slicer. Locate the adjustment nut at the lower end of the motor mounting plate, see below. Turn the adjustment nut clockwise with a wrench to increase tension on the drive belt. To reduce tension, turn the adjusting nut counterclockwise. The drive belt should be just tight enough, using moderate finger pressure, to allow a 3/8 inch deflection halfway between the motor drive pulley and the driven pulley.

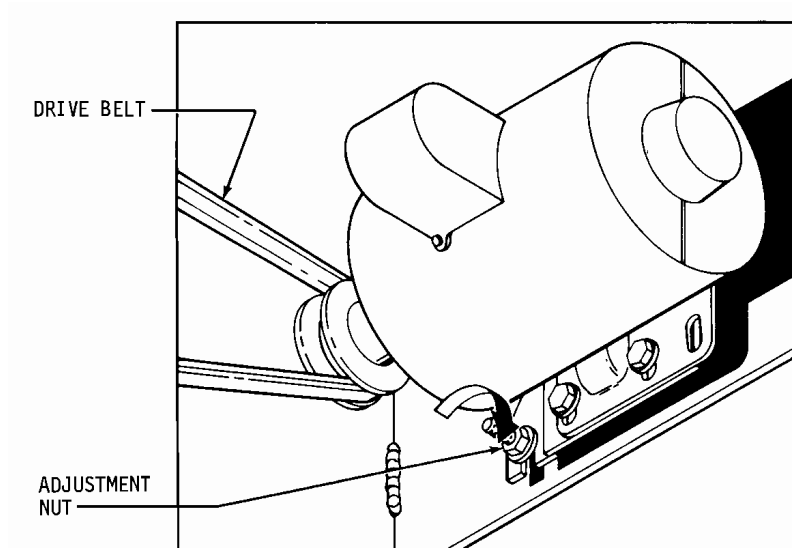

Replacing the Belt

Remove the infeed table, crumb chute, and discharge table. First remove the four black knobs securing the tables, (see the illustration below). In addition to the knobs the infeed and discharge tables are held in place by friction so pull the infeed table straight out and hard to separate them.

Turn the adjustment nut, at the lower end of the motor mounting plate, counterclockwise with a wrench to loosen the drive belt, see "Tightening the Belt" above.

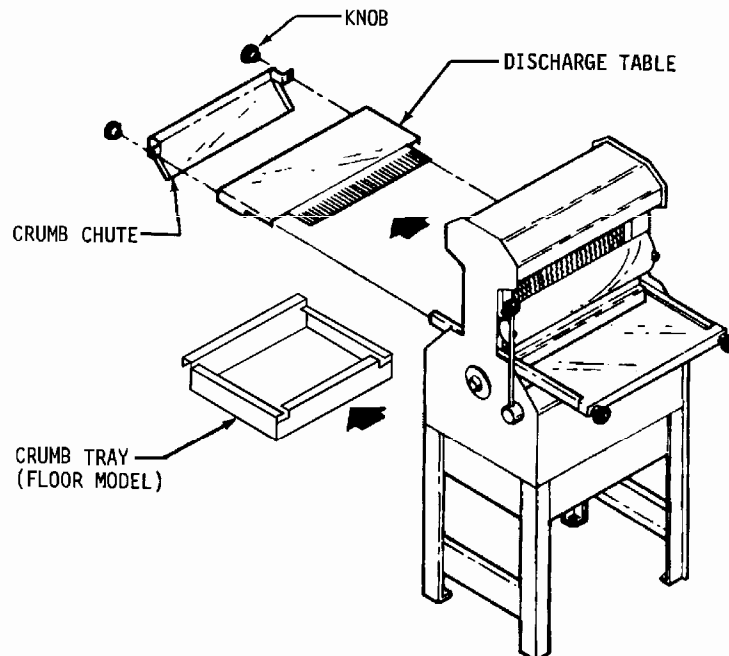

Disconnect the end of the connecting rod at the rocker by removing the two cap screws and cap as shown below. The drive belt may now be removed from the pulleys

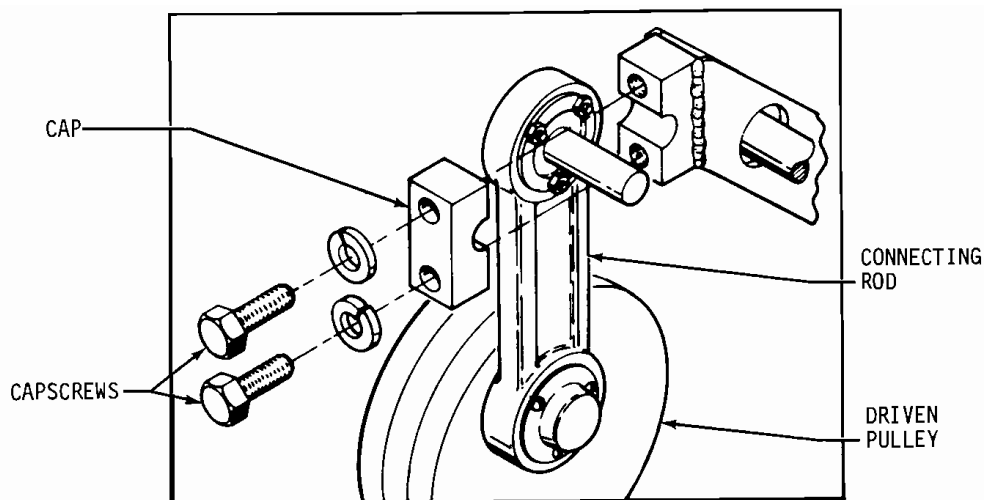

The new belt can be installed by reversing the removal procedure. Refer to the "Tightening the Belt" section to adjust the tension on the drive belt.

Adjusting the Blade Frames When Slices Vary in Thickness

Remove the discharge table from the slicer. Loosen, but, do not remove the two locking cams which secure the blade frame to the swing shaft. Remove the plastic plug over the set screw in the fixed collar, see below. Using an allen wrench, loosen, do not remove the set screw in the fixed collar. Using a ruler, (15" maximum), measure the distance between the blades. Gently tap the collar with a small mallet either to the right or left until the distances between the blades are equal. When satisfied with the location tighten the fixed collar's set screw and replace the plastic plug. Lastly tighten the two locking cams which secure the blade frame.

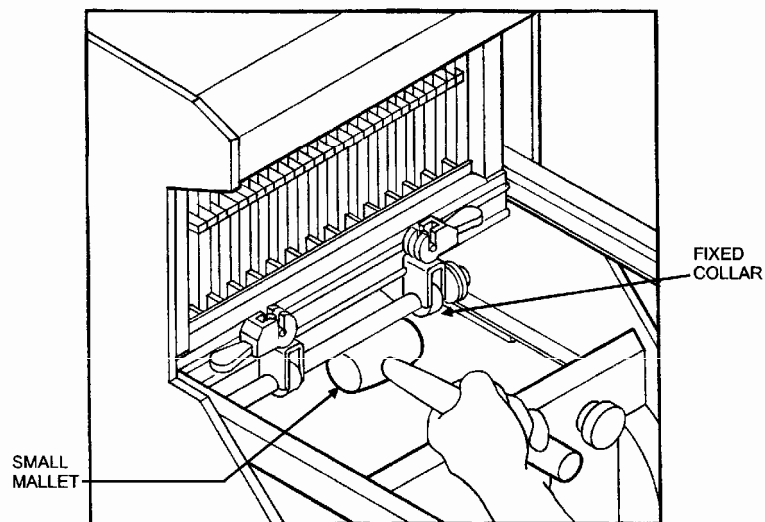

Adjusting the Clearance Between the Blade Frames

The distance between the blade frames is adjusted by rotating the eccentric pins located above the blade frames. Two wrenches are used to do this. One wrench is used to keep the eccentric pin from rotating while the second is used to loosen the lock nut on the end of the pin. This nut secures the pin in position once its proper location is determined. See the illustration below.

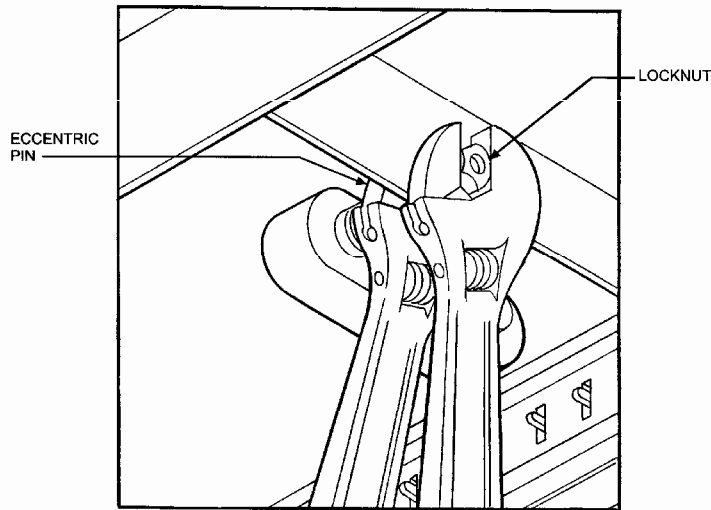

To adjust the eccentric, once the lock nut is loosened, rotate the pin using the wrench used to hold the pin. Rotate the pin, (it is possible that both pins will need adjustment at the same time), until the knives of the machine are in line within a 1/32 of an inch, (alternating blades should not appear be in front of or behind each other when viewed from the side). It is easiest to view this alignment by placing a straight edge horizontally along the blades midway between the ends of the blade on the blade's dull side, (discharge side), when the blade frames are in line or level. When the eccentric pins are in the desired position tighten each of the lock nuts to secure the position of the eccentrics. Check the blade frame clearance by turning the driven pulley by hand.

RECOMMENDED SPARE PARTS

<u>PART NUMBER</u>	<u>PART DESCRIPTION</u>	<u>NO. REQ'D</u>
5835-7705	Clip-Haripin	2
0777-0034	Pin-Eccentric	2
→ 0797-0059-2	Pin- STST Metric Blade Frame	2
0711-0002	Link-Top	2
5601-1119*	Belt-V 4L290 (60 Cycle Machines)	1
5709-1137*	Switch-Starter (1 Phase Machines)	1
5220-5001	Bearing-Driven Pulley (With Snap Ring)	1
5220-5040	Bearing-Driven Pulley	1
0797-0058-019	Stud-Driven Pulley	1
6904-6001	Gasket-Driven Pulley	1
0797-0071-4	Rod-Connecting ★	1
0797-0057-219	Stud-Swing	1
5220-4040	Bearing-Rocker Shaft	2
5220-0020	Bearing-Swing Shaft	4
6301-3609*	Motor-1/2 HP, 1-60-115/230	1
5757-8140 💬	Switch-Limit	1

***For Other Electrics Contact the Factory**

For Service Parts Call Oliver Products @ 800-253-3893

Rev. 1/20/09

ASSEMBLY DRAWING (MECHANICAL PARTS) MODEL 777-N Variety Slicer

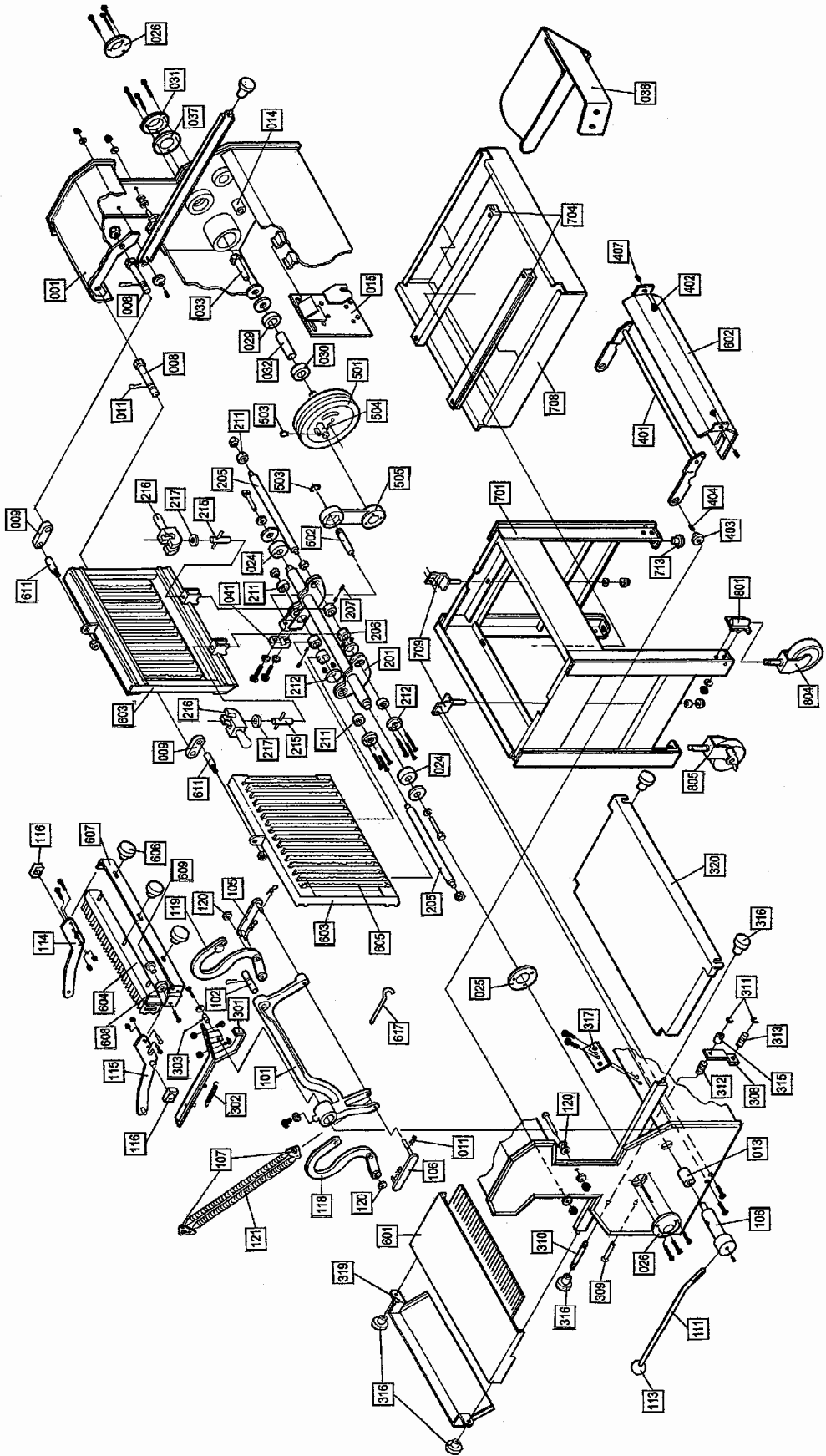

REV. 2/9/04

MECHANICAL REPLACEMENT PARTS LIST

ITEM NO	PART DESCRIPTION	PART NUMBER
001	Frame-Slicer	0777-0001-204
008	Pin-Eccentric	0777-0034
009	Link-Top	0711-0002
011	Clip-Hairpin	5835-7705
013	Bushing-Handle	0777-0063
014	Bushing-Yoke	0777-0071
015	Base-Motor	0777-0100-3
020	Stop-Holddown	0777-0981
024	Bearing-Rocker	5220-4040
025	Cap-Ball Bearing (Rocker)	4090-0233-0044
026	Cap-Ball Bearing (Rocker)	4090-0233-0023
029	Bearing-Dr. Pulley (With Snap Ring)	5220-5001
030	Bearing-Dr. Pulley	5220-5040
031	Cap-Dr. Pulley	4090-0244-0005
032	Collar	4130-0132-0204
033	Screw-Hex Hd. 3/8-24 X 3/4	5842-1802
037	Gasket-Dr. Pulley	6904-6001
038	Tray-Bagger	0797-2048-003
041	Cap-Clamp	0730-0023
101	Yoke-Swing	0777-0078-001
102	Pin-Yoke	0777-0033-001

For Service Parts Call Oliver Products @ 800-253-3893
Rev. 10/21/05

(Continued)

Mechanical Replacement Parts List (Continued)

ITEM NO	PART DESCRIPTION	PART NUMBER
105	Link-Pusher	0777-0912-001
106	Link-Pusher	0777-0913-001
107	Clip-Spring	0777-0085-001
108	Hub-Pusher	0777-0121-1
111	Lever-Pusher	0711-0024
113	Knob	5911-7002
114	Arm-RH Pusher	0777-0077-0011
115	Arm-LH Pusher	0777-0077-0012
116	Block-Slide	5500-2800
118	Arm-Front	0777-0082-002
119	Arm-Rear	0777-0083-002
120	Washer-Delrin	0777-0920
121	Spring	7025-5102
201	Frame-Rocker	0777-0047-101
205	Shaft-Swing	0797-0060-001
206	Collar	0797-0031-002
207	Collar-Fixed	0797-0031-003
211	Bearing-Swing Shaft	5220-0020
212	Cap-Ball Bearing	4090-0232-0018
215	Bolt-Eye	0777-0970
216	Cam	0777-0971

Mechanical Replacement Parts List (Continued)

ITEM NO	PART DESCRIPTION	PART NUMBER
217	Washer-Belleville	5852-0050
301	Arm-Switch Operator	0777-0119-101
302	Spring-Switch Operator	4605-1000-003
303	Bearing-Bronze	5254-0167
308	Stop-Arm	0777-0120-001
309	Stud-Stop	0777-0973
310	Stud-Knob	0777-0974
311	Washer-Horseshoe	0793-0084
312	Spring	4605-1000-0032
313	Spring	4605-1000-0033
315	Bushing-Rubber	5902-0100
316	Knob	5911-7000
317	Plate-Switch	0777-0898-001
319	Chute-Crumb	0777-0073-1
320	Table-Infeed	0777-0074-001
401	Frame-Holddown	0777-0975
402	Bushing-Holddown	0777-0065
403	Bushing-Frame	0777-0066
404	Screw-Pivot	0777-0068-001
407	Stud-Pivot	0777-0067-01
501	Pulley-Driven	0730-0005-001

For Service Parts Call Oliver Products @ 800-253-3893

(Continued)

Mechanical Replacement Parts List (Continued)

ITEM NO	PART DESCRIPTION	PART NUMBER
502	Stud-Swing	0797-0057-219
503	Ring-Retaining	5840-2825
504	Stud-Driven Pulley	0797-0058-019
505	Rod-Connecting	0797-0071-4
601*	Table-Outfeed	0777-0024-0XX
602*	Holddown	0777-0976-0XX
603*	Frame-STST Blade	0797-0300-5XX
604*	Pusher Assembly	0777-0978-0XX
605	Knife	0797-0029-1
606	Knob	5911-7000
607	Bar-Pusher (above 3/8" slice)	0777-0979
607	Bar-Pusher (3/8" slice & below)	0777-0979-001
608	Roller	0777-0982
609	Axle	0777-0983
611	Pin- STST Metric Blade Frame	0797-0059-2
617	 Tool-Blade Changing	0797-0183
701	Base	0777-0950

* Specify Slice Thickness

For Service Parts Call Oliver Products @ 800-253-3893
 Rev. 1/20/09

(Continued)

Mechanical Replacement Parts List (Continued)

<u>ITEM NO</u>	<u>PART DESCRIPTION</u>	<u>PART NUMBER</u>
704	Slide-Drawer	0777-0948
708	Tray-Extra Cap. Crumb	0777-0949
709	Holder-Base	0777-0046-101
713	Foot-Rubber	5902-0001
801**	Bracket-Caster	0777-0947-001
804**	Caster-Swivel	5902-2347
805**	Caster-Swivel W/Brake	5902-2348

** Optional Components

For Service Parts Call Oliver Products @ 800-253-3893

ELECTRICAL SINGLE PHASE

Wiring Diagram (Single Phase)

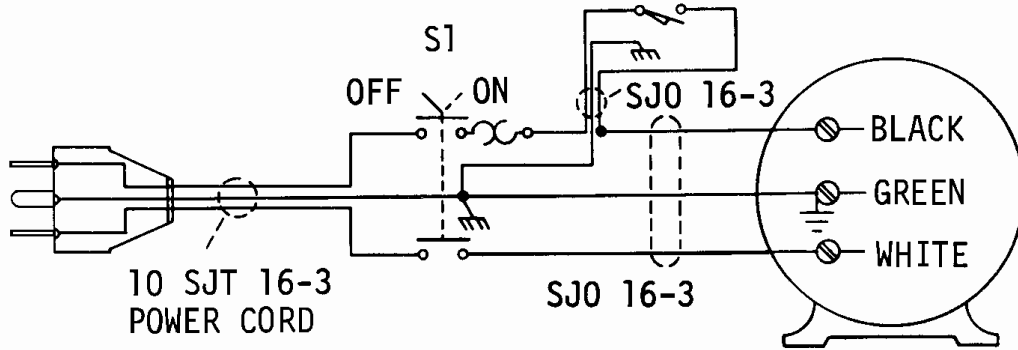

Assembly Drawing (Single Phase Electrics)

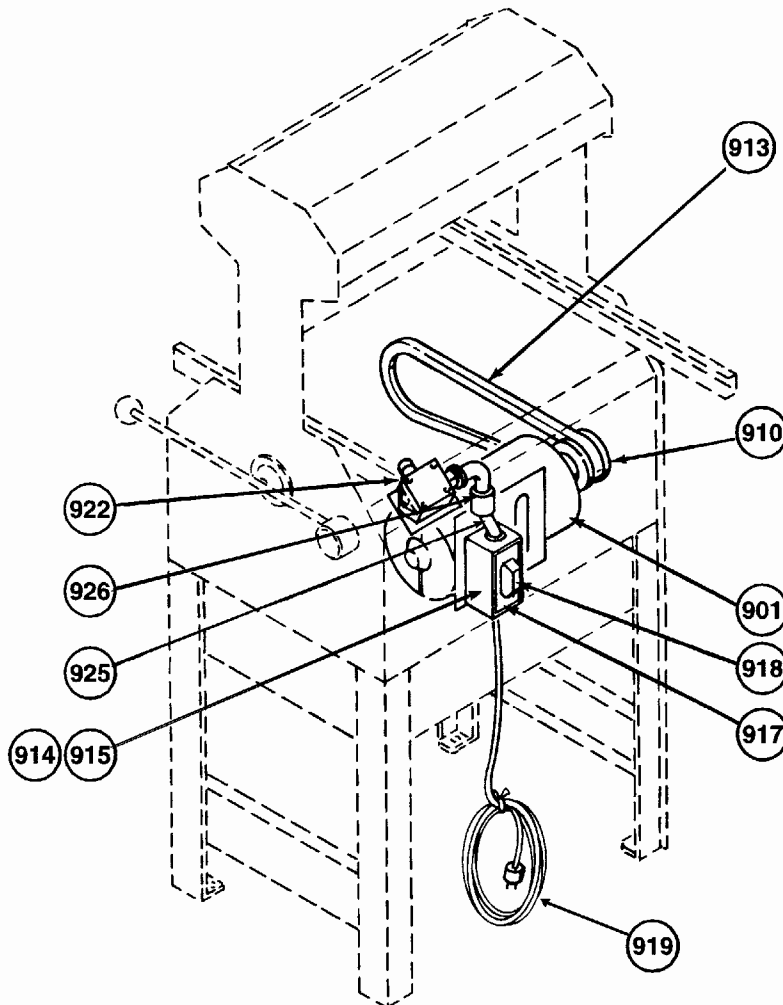

Parts List 1/2 HP, 115 VAC, 60 Hertz, 1 Phase

ITEM NO	PART DESCRIPTION	PART NUMBER
901	Motor-1/2 HP	6301-3609
910	Pulley-Motor	4575-7103-2001
913	Belt-V 4L290	5601-1119
914	Switch-Starter	5709-1137
915	Heater-Overload	5708-2430
917	Cover-Switch	0797-2131
918	Boot-Switch	5757-4515
919	Cord-Power W/Plug	0777-1040
922	Switch-Limit	5757-8140
925	Fitting-Offset Nipple	5766-7702
926	Fitting-90 Deg. Elbow	5766-7720

Parts List 1/2 HP, 230 VAC, 60 Hertz, 1 Phase

ITEM NO	PART DESCRIPTION	PART NUMBER
901	Motor-1/2 HP	6301-3609
910	Pulley-Motor	4575-7103-2001
913	Belt-V 4L290	5601-1119
914	Switch-Starter	5709-1137
915	Heater-Overload	5708-2423
917	Cover-Switch	0797-2131
918	Boot-Switch	5757-4515
919	Cord-Power W/Plug	0777-1078
922	Switch-Limit	5757-8140
925	Fitting-Offset Nipple	5766-7702
926	Fitting-90 Deg. Elbow	5766-7720

Parts List 1/2 HP, 220 VAC, 50 Hertz, 1 Phase

ITEM NO	PART DESCRIPTION	PART NUMBER
901	Motor-1/2 HP	6301-3940
910	Pulley-Motor	4575-7104-2004
913	Belt-V 4L290	5601-1120
914	Switch-Starter	5709-1137
915	Heater-Overload	5708-2425
917	Cover-Switch	0797-2131
918	Boot-Switch	5757-4515
919	Cord-Power W/Plug	0777-0980
922	Switch-Limit	5757-8140
925	Fitting-Offset Nipple	5766-7702
926	Fitting-90 Deg. Elbow	5766-7720

For Service Parts Call Oliver Products @ 800-253-3893

Rev 10-13-04

THIS PAGE WAS INTENTIONALLY
LEFT BLANK.

WARRANTY

PARTS

Oliver Products Company (Oliver) warrants that if any part of the equipment (other than a part not manufactured by Oliver) proves to be defective (as defined below) within one year after shipment, and if Buyer returns the defective part to Oliver within one year, Freight Prepaid to Oliver's plant in Grand Rapids, MI, then Oliver, shall, at Oliver's option, either repair or replace the defective part, at Oliver's expense.

LABOR

Oliver further warrants that equipment properly installed in accordance with our special instructions, which proves to be defective in material or workmanship under normal use within one (1) year from installation or one (1) year and three (3) months from actual shipment date, whichever date comes first, will be repaired by Oliver or an Oliver Authorized Service Dealer, in accordance with Oliver's published Service Schedule.

For purposes of this warranty, a defective part or defective equipment is a part or equipment which is found by Oliver to have been defective in materials workmanship, if the defect materially impairs the value of the equipment to Buyer. Oliver has no obligation as to parts or components not manufactured by Oliver, but Oliver assigns to Buyer any warranties made to Oliver by the manufacturer thereof.

This warranty **does not** apply to:

1. Damage caused by shipping or accident.
2. Damage resulting from improper installation or alteration.
3. Equipment misused, abused, altered, not maintained on a regular basis, operated carelessly, or used in abnormal conditions.
4. Equipment used in conjunction with products of other manufacturers unless such use is approved by Oliver Products in writing.
5. Periodic maintenance of equipment, including but not limited to lubrication, replacement of wear items, and other adjustments required due to installation, set up, or normal wear.
6. Losses or damage resulting from malfunction.

The foregoing warranty is in lieu of all other warranties expressed or implied AND OLIVER MAKES NO WARRANTY OF MERCHANTABILITY OR FITNESS FOR PURPOSE REGARDING THE EQUIPMENT COVERED BY THIS WARRANTY. Oliver neither assumes nor authorizes any person to assume for it any other obligations or liability in connection with said equipment. OLIVER SHALL NOT BE LIABLE FOR LOSS OF TIME, INCONVENIENCE, COMMERCIAL LOSS, INCIDENTAL OR CONSEQUENTIAL DAMAGES.

THIS PAGE WAS INTENTIONALLY
LEFT BLANK.

WARRANTY PROCEDURE

1. If a problem should occur, either the dealer or the end user must contact the Customer Service Department and explain the problem.
2. The Customer Service Manager will determine if the warranty will apply to this particular problem.
3. If the Customer Service Manager approves, a Work Authorization Number will be generated, and the appropriate service agency will perform the service.
4. The service dealer will then complete an invoice and send it to the Customer Service Department at Oliver Products Company.
5. The Customer Service Manager of Oliver Products Company will review the invoice and returned parts, if applicable, and approve for payment.

THIS PAGE WAS INTENTIONALLY
LEFT BLANK.

RETURNED PARTS POLICY

This policy applies to all parts returned to the factory whether for warranted credit, replacement, repair or re-stocking.

Oliver Products Company requires that the customer obtain a Return Material Authorization (RMA) number before returning any part. This number should appear on the shipping label and inside the shipping carton as well. All parts are to be returned prepaid. Following this procedure will insure prompt handling of all returned parts.

To obtain an RMA number contact the Repair Parts Department toll free at (800) 253-3893.

Parts returned for re-stocking are subject to a **RE-STOCKING CHARGE**.

Thank you for your cooperation,

Repair Parts Manager
Oliver Products Company