



Grand Rapids, Michigan, U.S.A. 49504-5298

USER'S OPERATING AND INSTRUCTION MANUAL

MODEL 797-21"

BREAD SLICER

OPTION SHEET

SLICE SPACING

ELECTRICS

- 1/2 HP, 1-60-115/230
- 1/2 HP, 1-50-110/220
- 1/2 HP, 3-60-230/460
- 1/2 HP, 3-50-220/440/415
- 1/2 HP, 3-60-208
- 1/2 HP, 3-50-380

DRIVEN PULLEY

- High Speed
- Power Belt

INFEED

- 48" Gravity
- 48" Power Belt
- Spring Feed

OUTFEED

- Standard
- Curved
- Spring

MISCELLANEOUS OPTIONS

- Casters
- Bagging Scoop

THIS PAGE WAS INTENTIONALLY
LEFT BLANK.

OLIVER PRODUCTS COMPANY
797-21" BREAD SLICER MANUAL

TABLE OF CONTENTS

	PAGE
LIST OF ILLUSTRATIONS.....	iii
SAFETY STATEMENTS.....	v
UNCRATING & INSTALLATION	
Uncrating 48" Gravity or Power Feed Slicer.....	1
Remove Option Package.....	2
Installing Holddown on Gravity or Power Feed Slicer.....	2
Installing Outfeed Side Guide Extensions on Gravity or Power Feed Slicers.....	2
Remove 2x4 from Spring Feed Slicer.....	3
Remove Slicer from Shipping Platform.....	3
Installing Optional Casters on Slicers.....	5
MAXIMUM PRODUCT SIZES	
Capacity.....	7
Slice Spacing.....	7
SPECIFICATIONS.....	8
OPERATING INSTRUCTIONS	
Adjusting Gravity Feed or Power Feed Slicers.....	11
Operating Gravity Feed or Power Feed Slicers.....	14
Operating Gravity Feed Last Loaf Pusher.....	14
Operating Spring Feed Slicer.....	15
MAINTENANCE	
Removing Blade Frame From Discharge Side of Gravity Feed or Power Feed Slicers.....	18
Removing Blade Frame From Infeed Side of Gravity Feed Slicer.....	18
Removing Blade Frames From Spring Feed Slicer.....	22
Replacing Blade Frames - All Models.....	23
Changing Cutting Knives.....	23
Tightening Belt.....	25
Replacing Belt.....	25
Tracking Power Feed Infeed Belt.....	27
Replacing Infeed Belt on Power Feed Slicers.....	28
LUBRICATION.....	30

TABLE OF CONTENTS (CONTINUED)

	PAGE
CLEANING	
Cleaning Gravity Feed or Power Feed Slicers.....	31
Cleaning Spring Feed Slicers.....	31
BLADE FRAME ADJUSTMENT	
Slices Vary in Thickness.....	32
Blade Frame Clearance Adjustment.....	33
TROUBLESHOOTING.....	34
ELECTRICAL COMPONENTS PARTS LIST	
Single Phase - Gravity or Power Feed Slicers.....	37
3 Phase - Gravity or Power Feed Slicers.....	39
Single Phase - Spring Feed Slicers.....	42
RECOMMENDED SPARE PARTS.....	43
MECHANICAL PARTS LIST.....	45
WARRANTY.....	GEN 040225
WARRANTY PROCEDURE	GEN 040226
RETURNED PARTS POLICY.....	GEN 040227

LIST OF ILLUSTRATIONS

FIGURE NO.	TITLE	PAGE
1	Uncrating 48" Gravity or Power Feed Slicer	1
2	Holddown Installation	2
3	Crumb Tray Removal	3
4	Removing Slicer From Shipping Platform	4
5	Lowering Slicer Onto Blocks	6
6	Locking Caster Installation	6
7	48" Gravity Feed Slicer	8
8	Power Feed Slicer	9
9	Spring Feed Slicer	10
10	Adjust Slicer for Product Height	11
11	Adjust Slicer for Product Length	12
12	Adjust Outfeed Side Guides	13
13	Gravity Feed Last Loaf Pusher	15
14	Adjust Outfeed Guides	16
15	Operating Spring Feed Slicer	17
16	Swing Discharge Table Out	19
17	Removing Clip From Eccentric Pin	20
18	Removing Capscrews Securing Blade Frames	20
19	Removing Blade Frames	21
20	Removing Chute Guard	21
21	Swing Out Tables From Spring Feed Slicer	22
22	Blade Removal Using Knife Tool	24
23	Cutting Knife Installation	24
24	Removing Discharge Table and Crumb Tray	26
25	Adjusting Drive Belt	27
26	Removing Connecting Rod	28
27	Adjusting Power Feed Belt Tracking	29
28	Adjusting Slice Thickness	32
29	Adjusting Blade Frames Using Eccentric Pins	33

LIST OF ILLUSTRATIONS (Continued)

FIGURE NO.	TITLE	PAGE
30	Single Phase Gravity or Power Feed Wiring Diagram	36
31	3 Phase Gravity or Power Feed Wiring Diagram	38
32	Single Phase Spring Feed Wiring Diagram	41
33	Slicer Chute Assemblies	44
34	Slicer Frame Base Assembly and Optional Parts	48
35	Rocker Blade Frame Assembly	51
36	Spring Feed Slicer Exploded View	54

The use of the words WARNING, CAUTION, and NOTE in this manual should be guided by the following:

WARNING

Operating procedures, techniques, etc., which may result in personal injury or loss of life if not carefully followed.

CAUTION

Operating procedures, techniques, etc., which may result in damage to equipment if not carefully followed.

NOTE

An operating procedure, technique, etc., which is considered essential to emphasize.

UNCRATING AND INSTALLATION

UNCRATING 48" GRAVITY OR POWER FEED SLICER

Taking care not to damage slicer, use a hammer and pry bar to remove the boards enclosing the slicer. Remove the boards in the sequence as shown in Figure 1. Once the boards have been removed from the top and ends of the shipping carton, the sides may be removed. Carefully pry the sides away from the 2x4s holding the top of the slicer in place. Finish removing the sides from the shipping platform with the hammer and prybar.

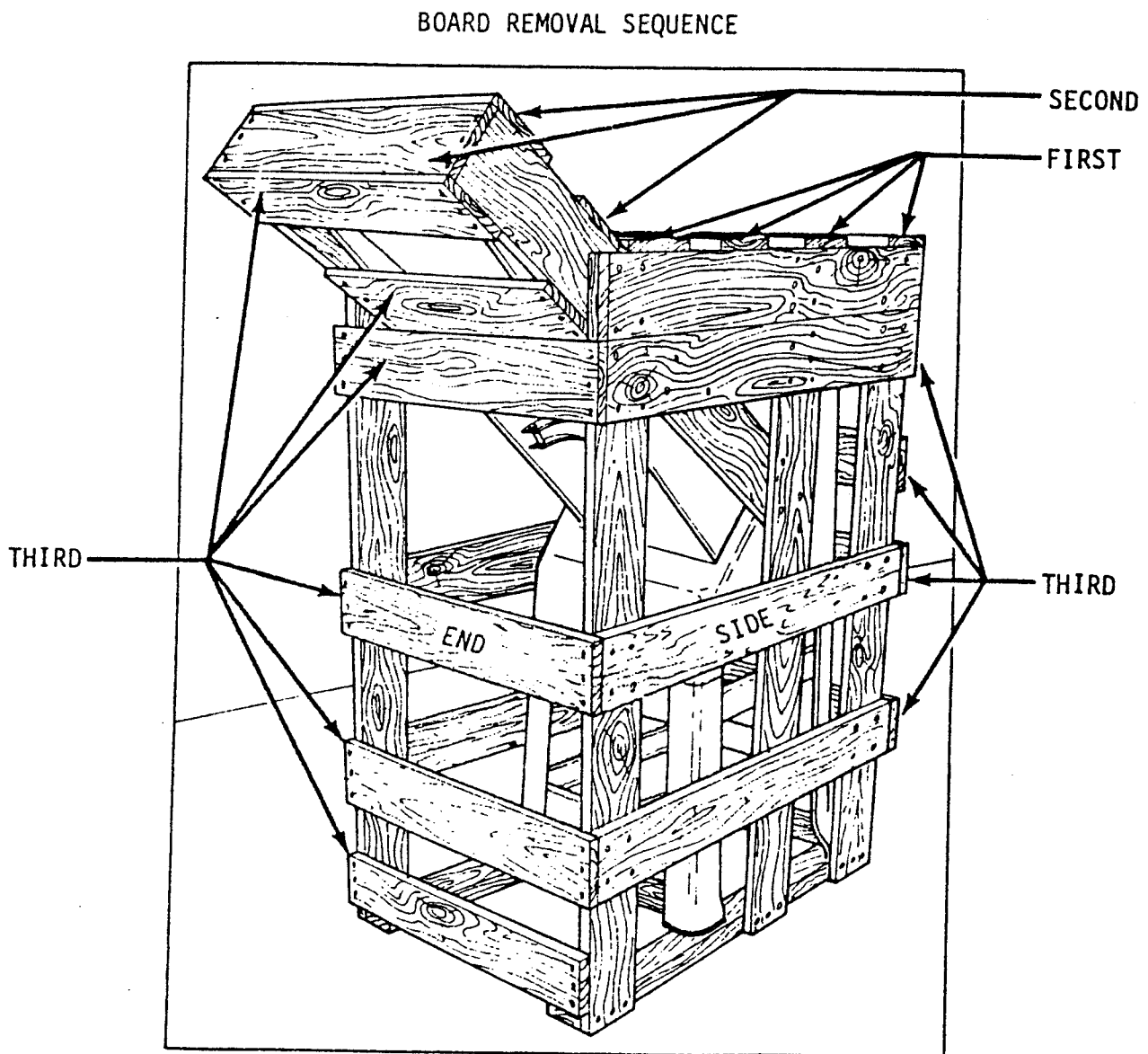

Figure 1. Uncrating 48" Gravity or Power Feed Slicer

REMOVE OPTION PACKAGE (CASTERS, BAG SCOOP, ETC.)

Locate Option Package enclosed in carton and set aside.

INSTALLING HOLDDOWN ON GRAVITY OR POWER FEED SLICER

Use a wrench to remove the bolt holding the 2x4 to holddown adjustment bracket. Locate holddown and adjustment knob taped to slicer in paper bag. Insert holddown into knives and secure by screwing knob into threaded hole as shown in Figure 2.

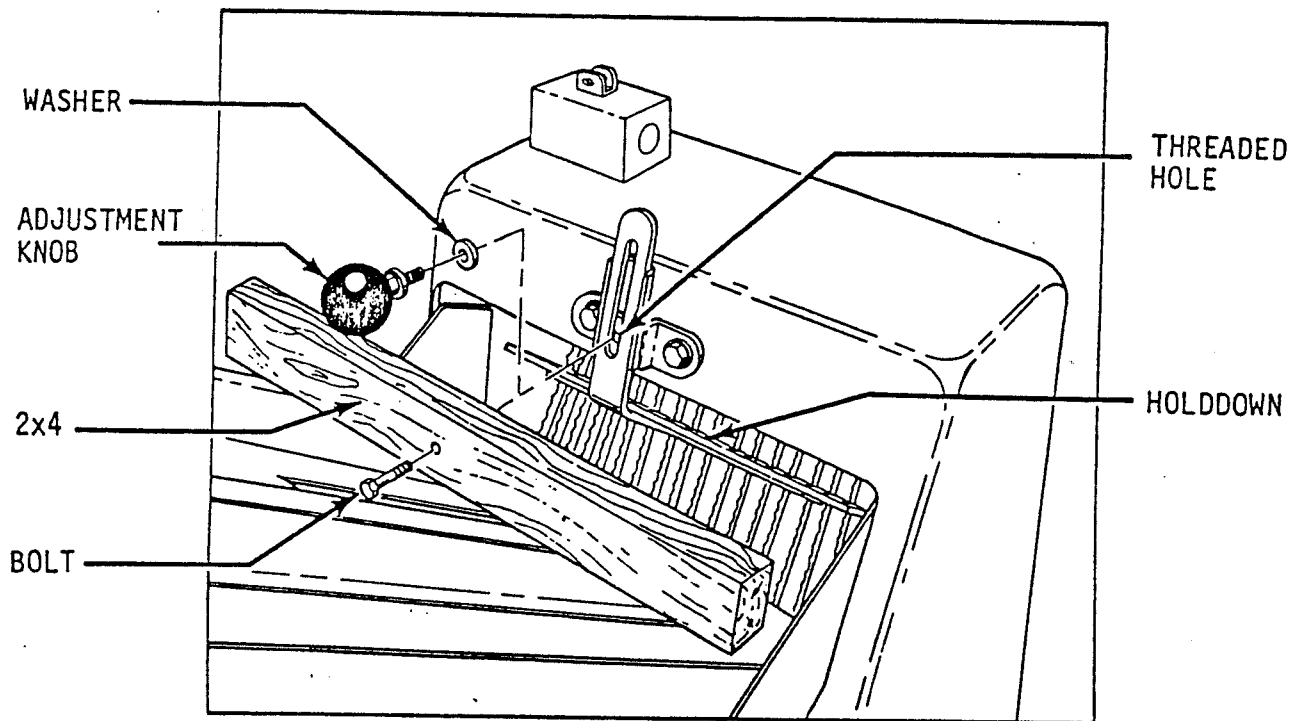

Figure 2. Holddown Installation

INSTALLING OUTFEED SIDE GUIDE EXTENSIONS ON GRAVITY OR POWER FEED SLICERS

Locate side guide extensions in paper bag with holddown. Slide extensions over side guides as shown in Figure 3. They should fit snugly.

REMOVE 2x4 FROM SPRING FEED SLICER

Remove the shipping 2x4 attached to discharge side of slicer by removing two bolts using a wrench.

REMOVE SLICER FROM SHIPPING PLATFORM

Remove the crumb tray from the slicer. See Figure 3.

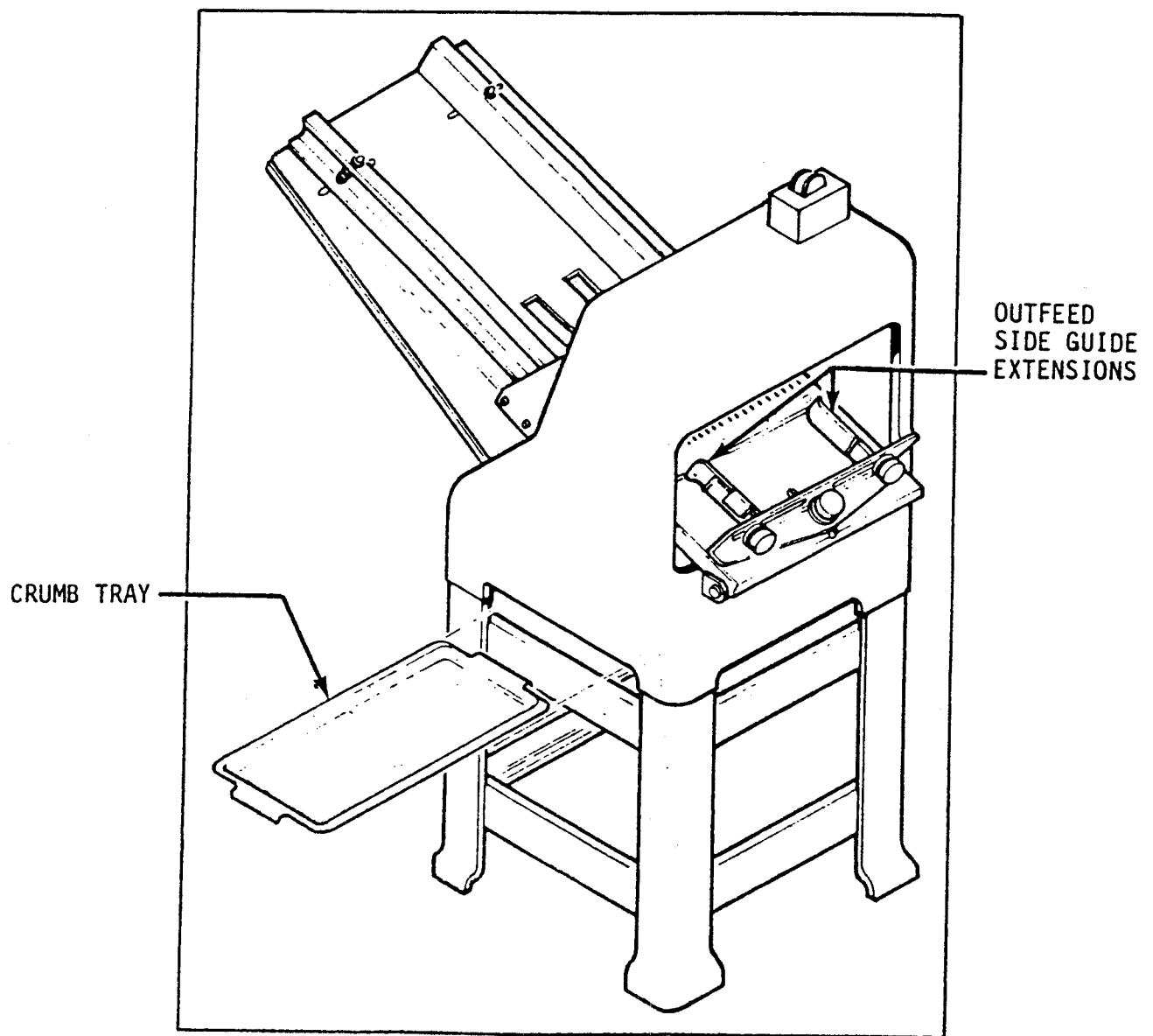

Figure 3. Crumb Tray Removal

WARNING

Slicer is heavy, use proper technique when lifting. Keep back straight, knees bent, and lift with legs. Use gloves to protect hands.

Lift the slicer off of the shipping platform with one person standing on each side of the slicer as shown in Figure 4. Set slicer down on level floor.

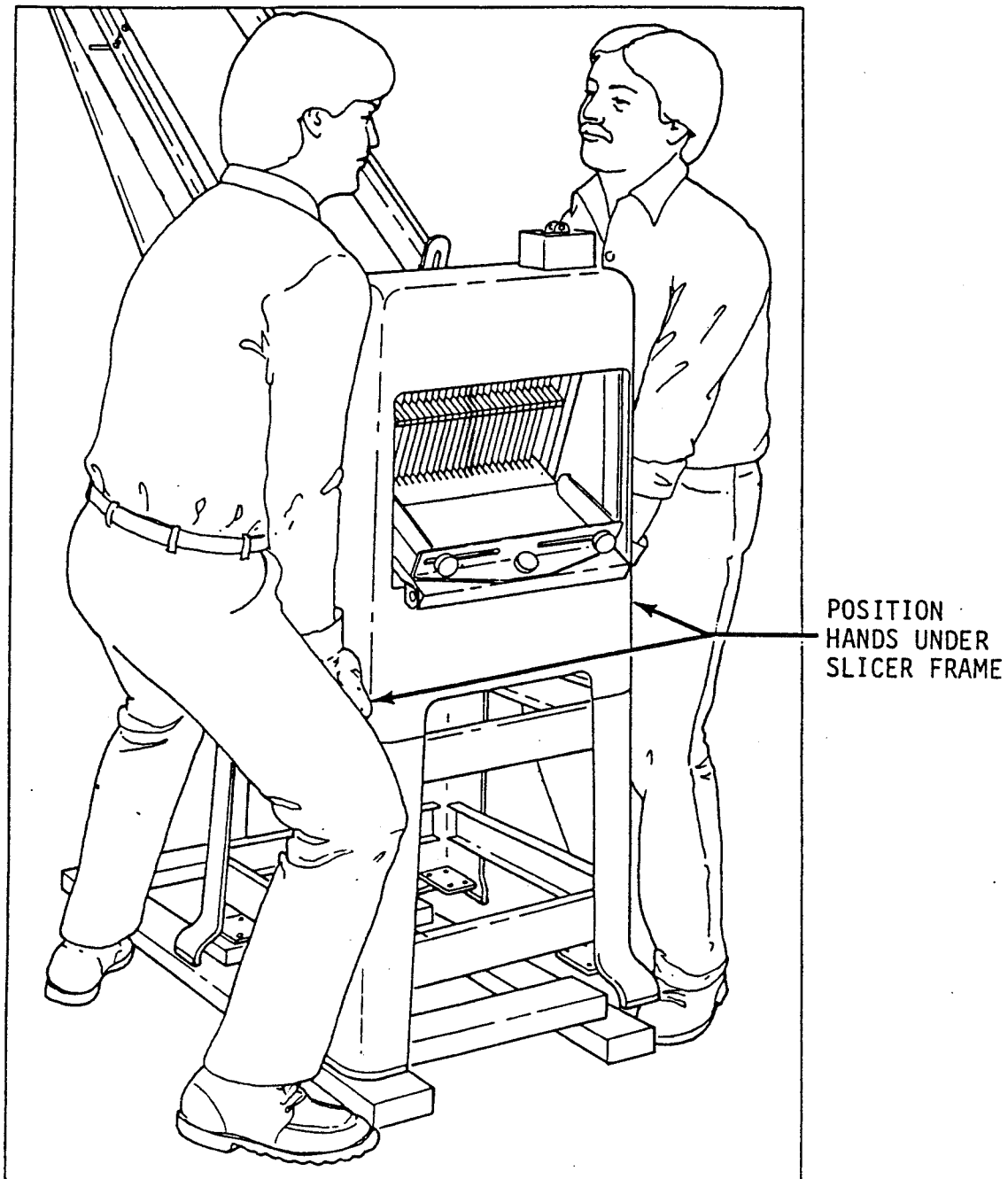

Figure 4. Removing Slicer From Shipping Platform

INSTALLING OPTIONAL CASTERS ON SLICERS

Place blocks on floor approximately 8 and 38 inches from discharge side of slicer. Lower holddown to lowest position and tighten holddown adjustment knob to prevent outfeed table from swinging out. With one person on each side of the slicer, gently lower slicer onto blocks. See Figure 5.

NOTE

Spring feed slicer must be laid down onto blocks on its side to avoid damaging tables.

Locate casters, 1/4-inch bolts and lockwashers in option package. Using a wrench to turn bolts into threaded holes, install both locking casters on the discharge side of slicer. See Figure 6. Set the brakes tightly on both locking casters (this will help to keep the wheels from rolling when lifting slicer back to upright position).

Install the two rigid casters in the same manner on the infeed side of slicer.

CAUTION

Never attempt to lift slicer by the infeed chute as damage to the slicer may result.

Chock the locked wheels using a 2x4 to ensure that they will not roll or skid when lifting the slicer back to the upright position. Carefully lift slicer back to upright position. Release brakes to roll slicer to desired position.

NOTE

On exported slicers an oil coating is sprayed on the machines for protection while in transit. Carefully remove oil coating, using an ordinary household type cleaner, before using slicer.

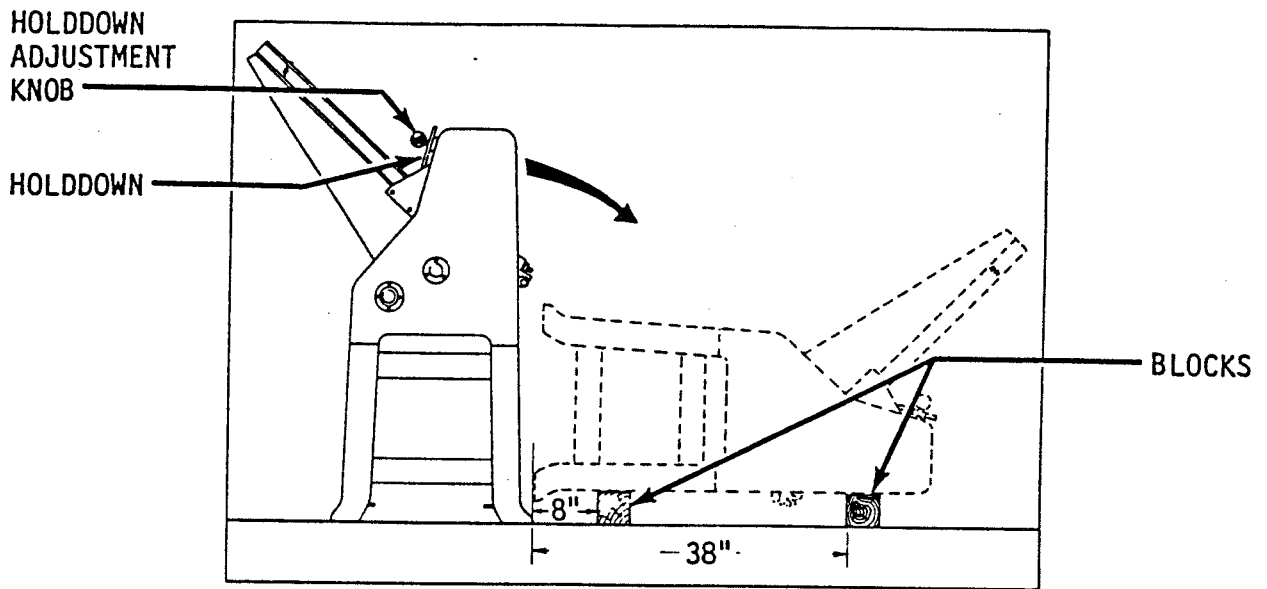

Figure 5. Lowering Slicer Onto Blocks

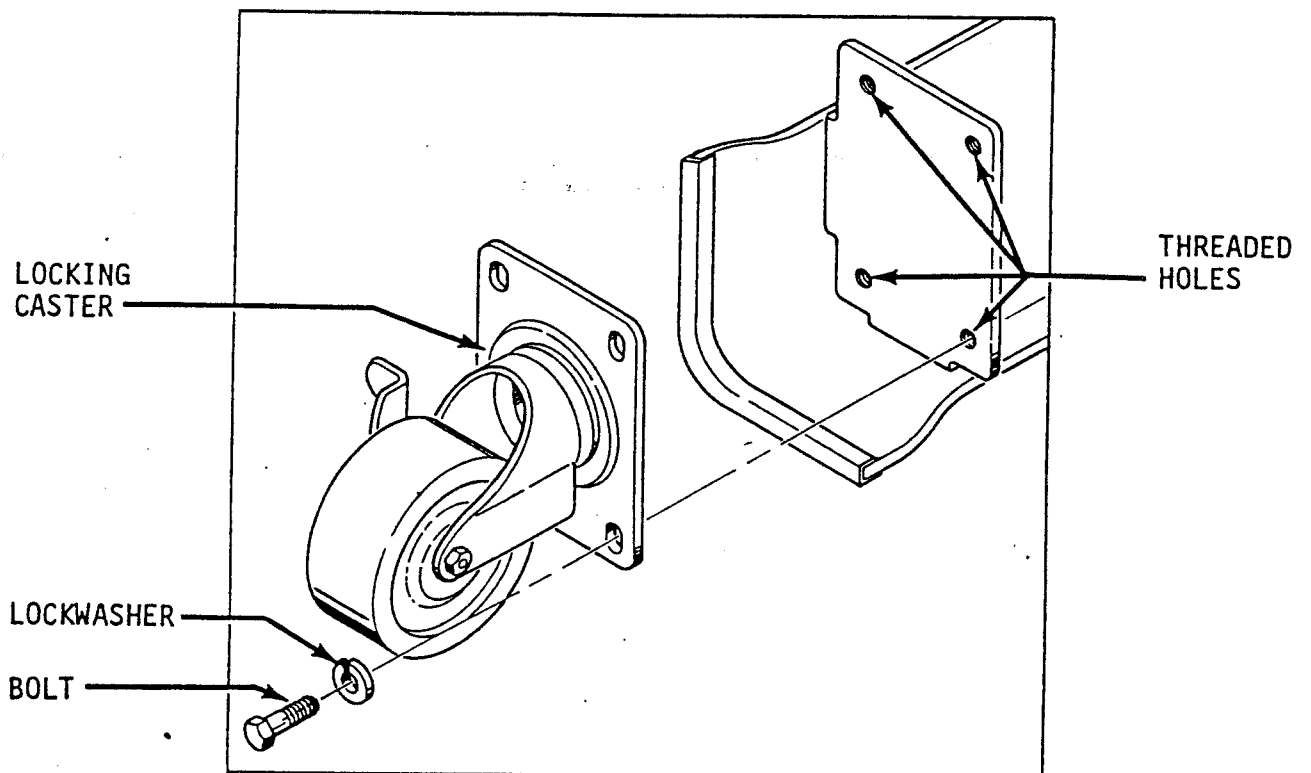

Figure 6. Locking Caster Installation

MAXIMUM PRODUCT SIZES

CAPACITY: (PRODUCT)

Gravity Feed and Power Feed Slicers

21 inches (53 cm) length x 5 inches (13 cm) height

Spring Feed Slicer

21 inches (53 cm) length x 10 1/2 inches (27 cm) width x 6 inches (15 cm) height

SLICE SPACING:

Standard 1/2" (12.7 mm)
Optional (at extra cost) 3/8, 7/16, 9/16, 5/8, 3/4 "
(9.5, 11.1, 14.3, 15.9, 19 mm)

Others Available; Contact Factory

SPECIFICATIONS

FLOOR SPACE DIMENSIONS

See Figures 7 through 9 for the slicers overall floor space dimensions.

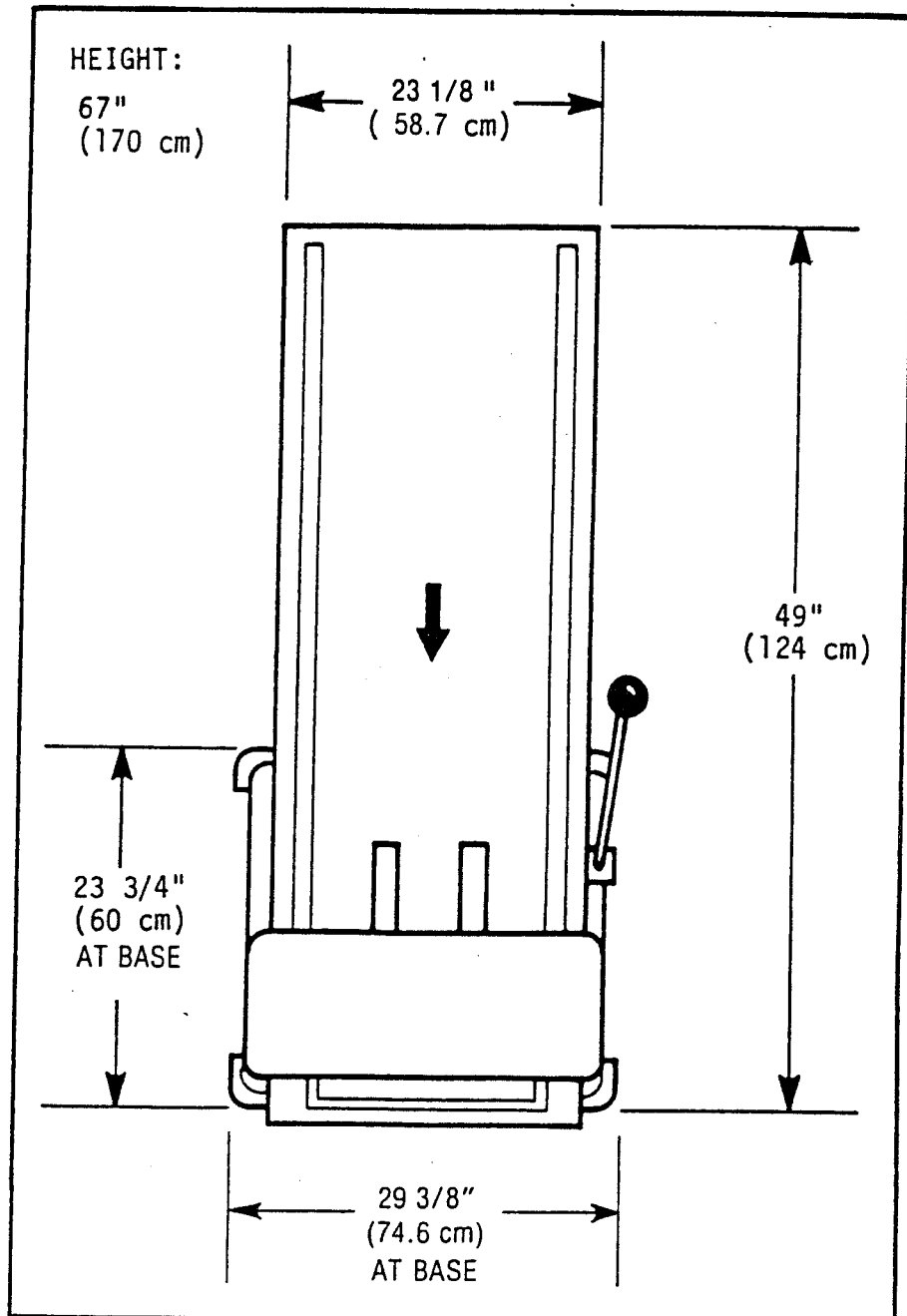

Figure 7. 48" Gravity Feed Slicer

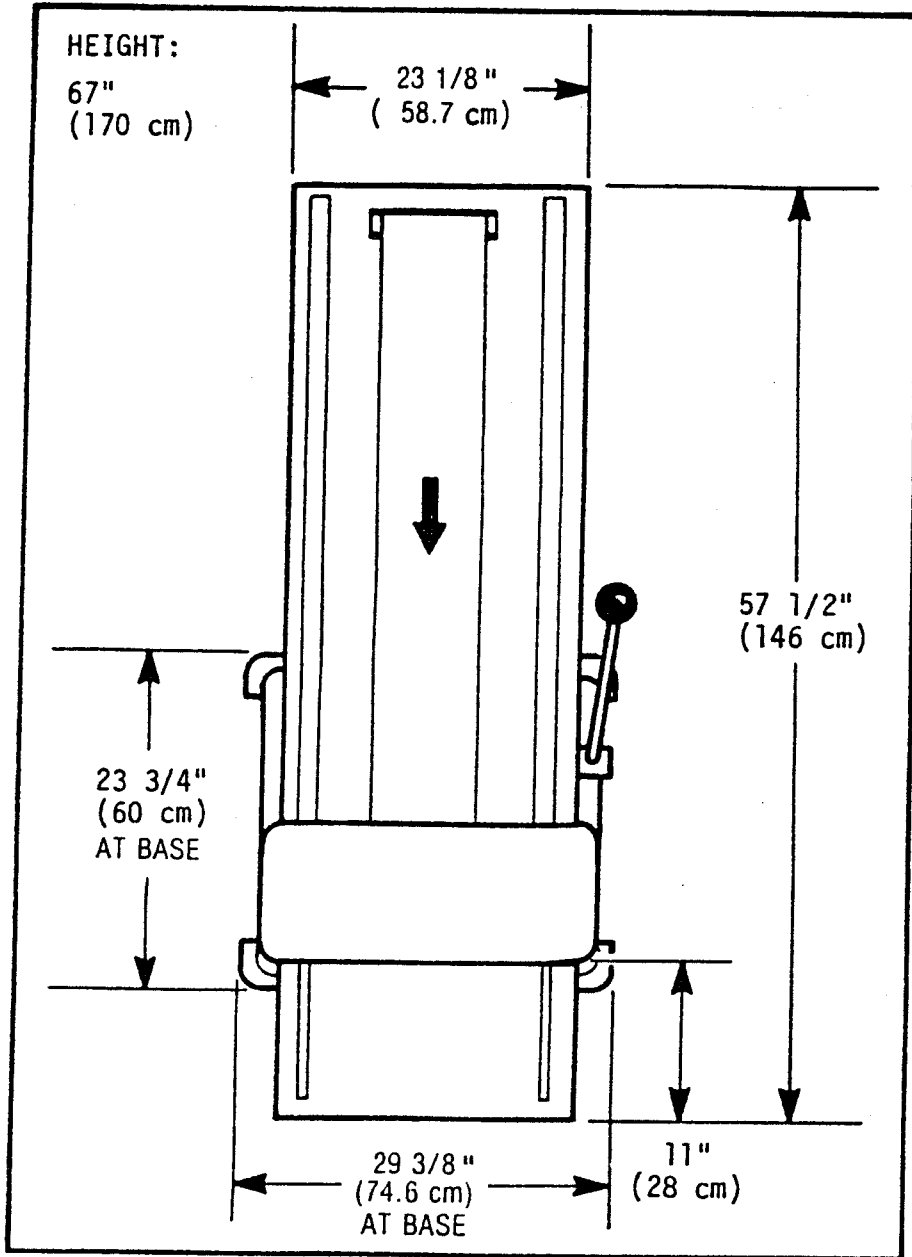

Figure 8. Power Feed Slicer

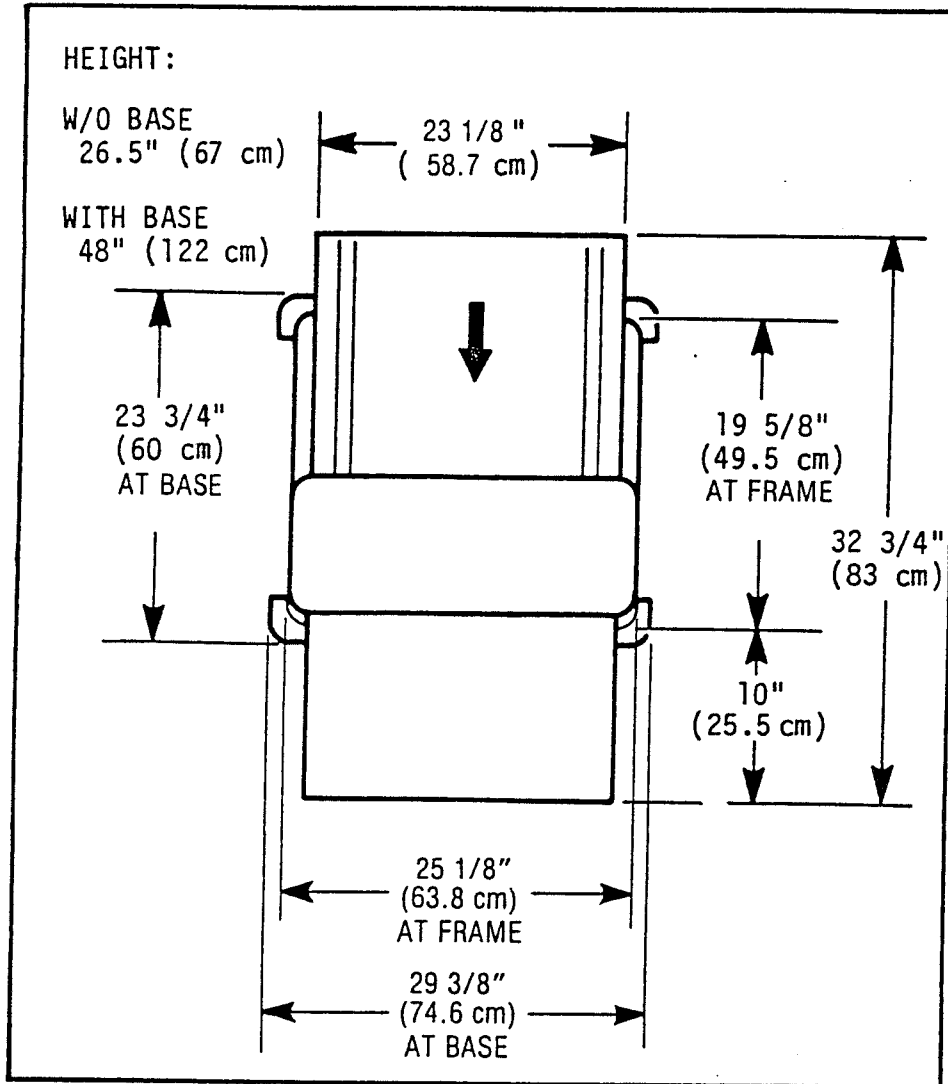

Figure 9. Spring Feed Slicer

OPERATING INSTRUCTIONS

ADJUSTING GRAVITY FEED OR POWER FEED SLICERS

1. Adjust Slicer for Product Height

Loosen holddown adjustment knob. Adjust the holddown so the product just clears the holddown as it passes through the cutting knives. Tighten holddown adjustment knob. See Figure 10. Proper adjustment of holddown will prevent product from jumping as it passes through the cutting knives.

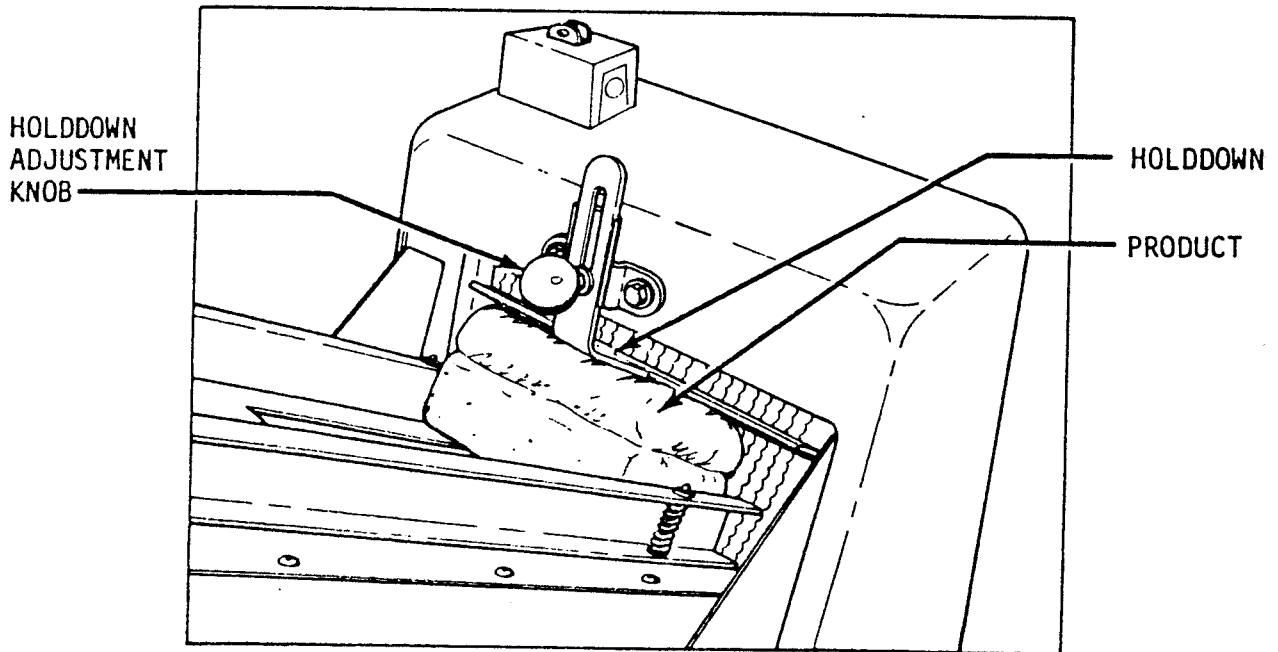

Figure 10. Adjust Slicer for Product Height

2. Adjust Slicer for Product Length

Using a typical product, adjust the infeed chute side guides by hand pressure. See Figure 11. Set side guides approximately 1/8 inch wider than the product.

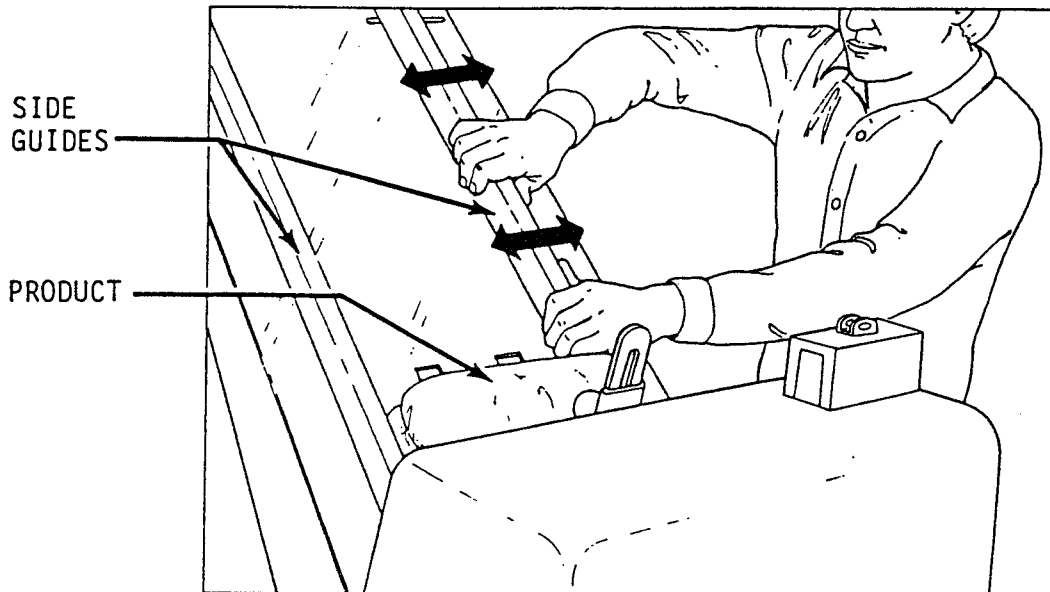

Figure 11. Adjust Slicer for Product Length

3. Adjust Outfeed Side Guides (Gravity Feed with Standard Outfeed Table)

Adjust side guide extensions so that they are approximately 1/4 inch from the cutting knives. Loosen outfeed side guide adjustment knobs. Adjust the outfeed side guides to align with the infeed guides. See Figure 12. Tighten side guide adjustment knobs. Proper adjustment of these guides will keep the end slices from falling over as the product exits the cutting knives.

NOTE

On power feed slicers or slicers with curved outfeed tables, align the outfeed guides with the infeed guides by using hand pressure as in Step 2.

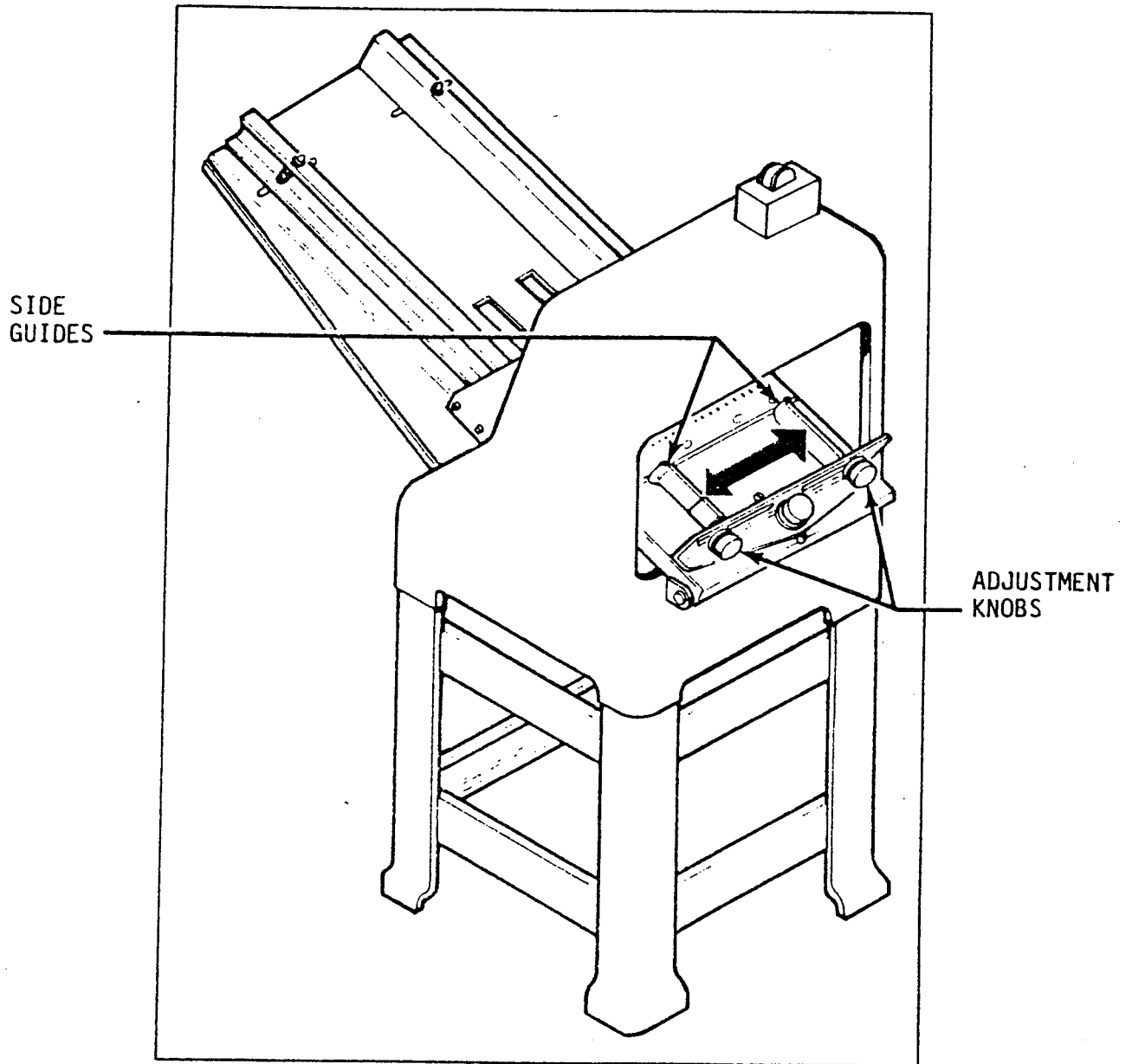

Figure 12. Adjust Outfeed Side Guides

OPERATING GRAVITY FEED OR POWER FEED SLICERS

Once the slicer has been properly adjusted for product clearance, the infeed chute may be loaded with the product to be sliced. Flipping the starting switch to the ON position will begin operation. Remove each sliced product from the discharge table as it is sliced.

NOTE

The gravity feed slicer's optimum operating efficiency will be maintained by ensuring that the infeed chute is kept fully loaded. The speed of the slicer is dependent on the number of products in position on the infeed chute, sharpness of cutting knives, and texture of product.

OPERATING GRAVITY FEED LAST LOAF PUSHER

The 48" gravity feed slicer is equipped with a last loaf pusher to feed the last product on the infeed chute through the cutting knives. To operate the last loaf pusher, simply pull the last loaf pusher lever toward the discharge side of slicer. See Figure 13. Return lever to upper position before reloading the infeed chute.

WARNING

Always use care whenever working near moving cutting knives.

Once the last loaf pusher has fed the product into the cutting knives as far as it can, it may be necessary to pull the product the rest of the way through the cutting knives by hand.

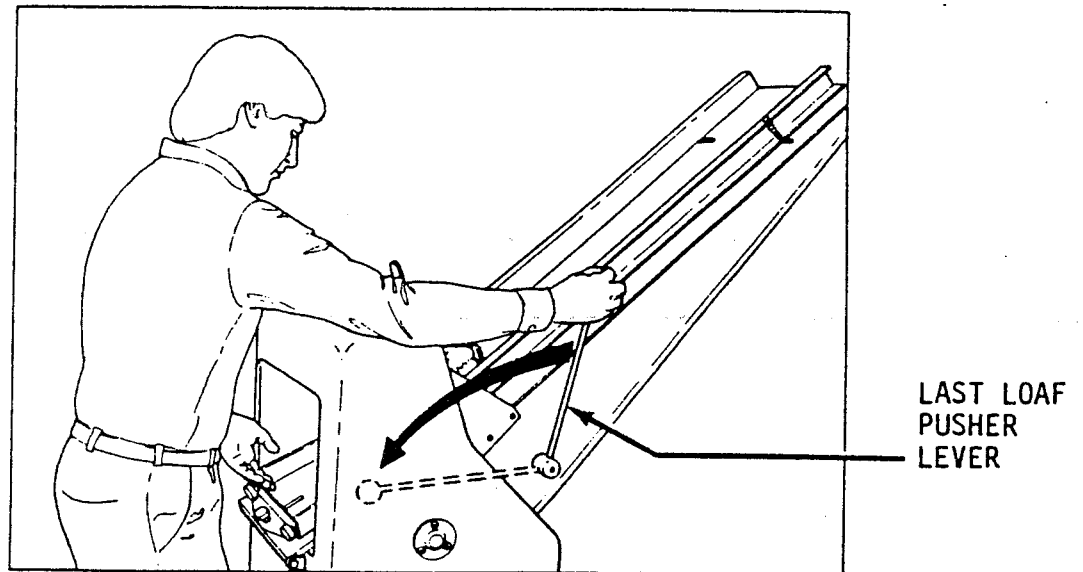

Figure 13. Gravity Feed Last Loaf Pusher

OPERATING SPRING FEED SLICER

First adjust Outfeed guides by hand to suit length of product. See Figure 14. Stand on the Infeed side of slicer, grasp pusher knob with left hand, and pull Infeed pusher completely back. With your right hand, place the product to be sliced between the pusher and the cutting knives. See Figure 15.

WARNING

Do not allow hand to remain between product and cutting knives when releasing pusher.

With your right hand, flip the start switch to start motor. Release infeed pusher allowing pusher to move product through cutting knives.

Slicer motor will shut off automatically when product is completely sliced. Remove sliced product from discharge table.

Motor will automatically restart when the pusher is pulled back.

On extremely hard-crusted loaves of bread, the slicing operation may be assisted by applying pressure to the infeed pusher.

WARNING

Always turn the Main Switch OFF after each operating period to prevent accidental start-up of the slicer.

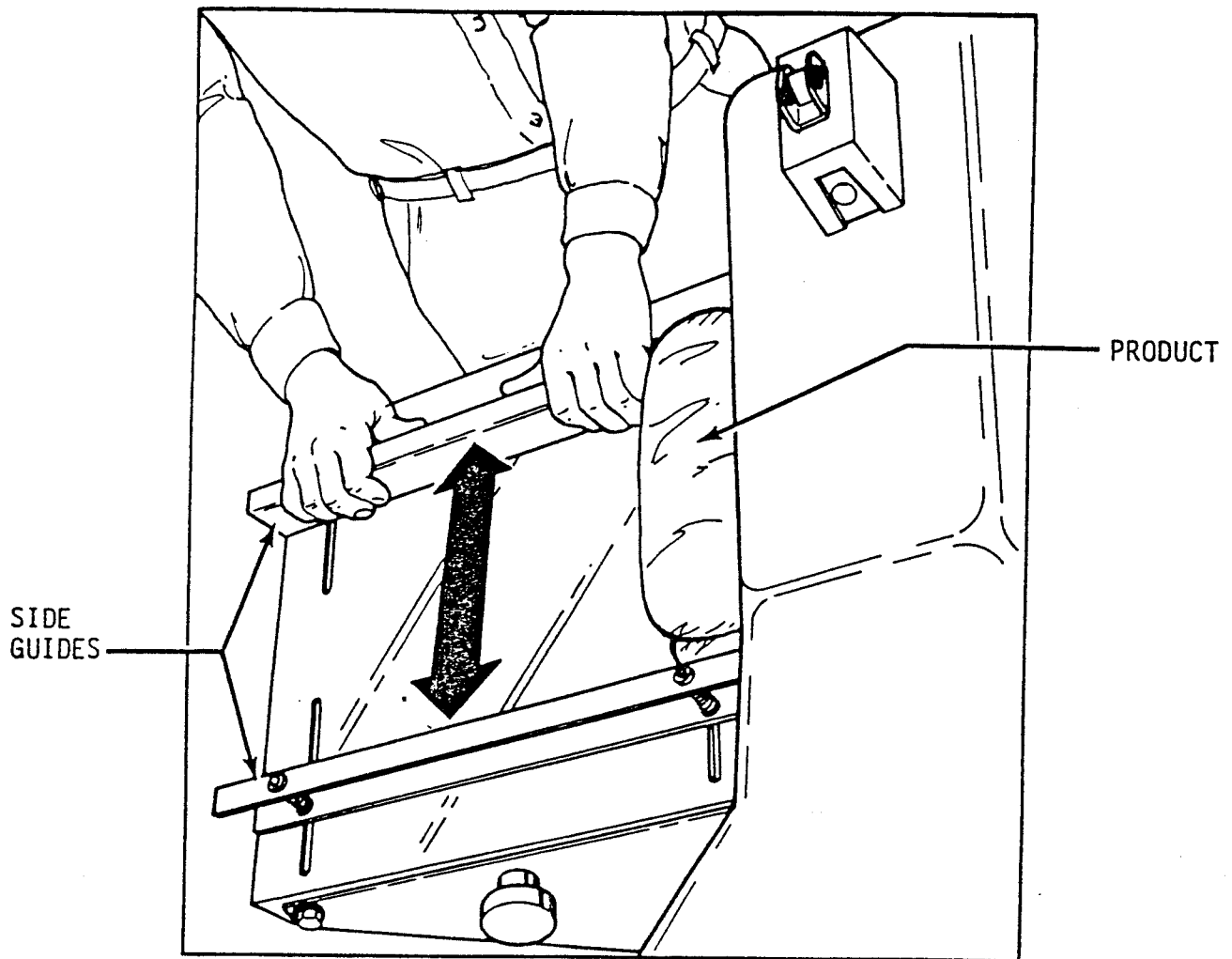

Figure 14. Adjust Outfeed Guides

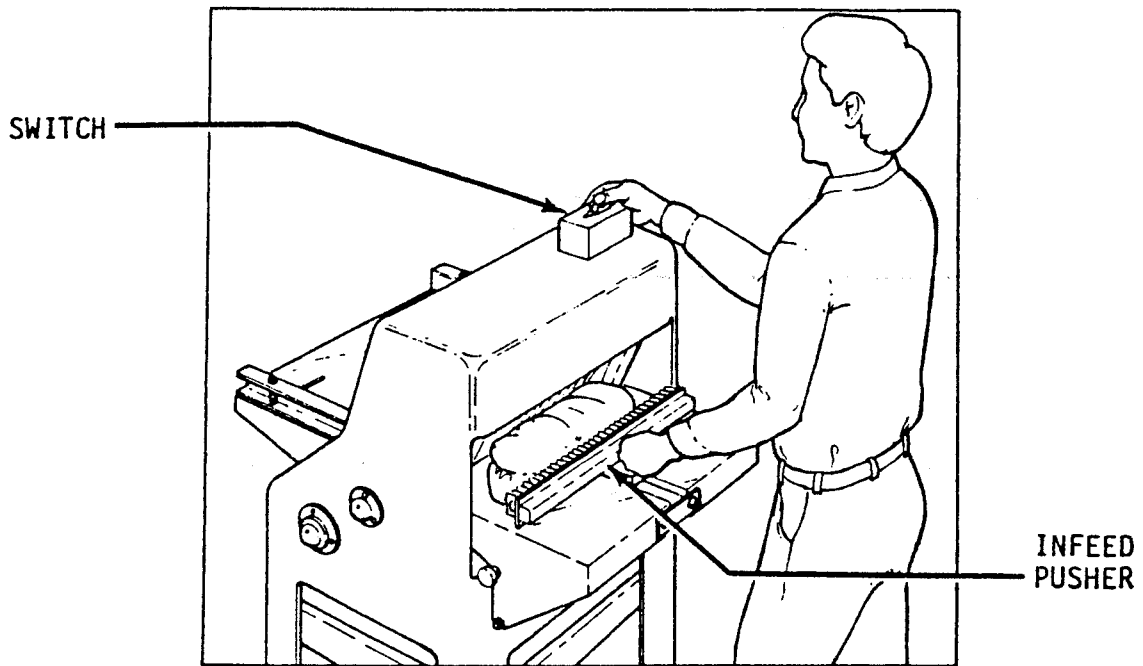

Figure 15. Operating Spring Feed Slicer

MAINTENANCE

WARNING

Always unplug slicer before performing any maintenance task.

REMOVING BLADE FRAME FROM DISCHARGE SIDE OF GRAVITY FEED OR POWER FEED SLICERS

Swing discharge table out from the slicer. See Figure 16. Pull clip from eccentric pin and slide the top link toward eccentric pin mounting brace. See Figure 17. Use a wrench to loosen and remove the two capscrews which fasten the blade frame feet to the rocker shaft. See Figure 18.

WARNING

Cutting knives are extremely sharp. Always handle blade frames with care.

Carefully lift the blade frame from the slicer. See Figure 19.

REMOVING BLADE FRAME FROM INFEED SIDE OF GRAVITY FEED SLICER

NOTE

Removal of the infeed side blade frame from power feed slicer is very difficult and is not necessary in order to change infeed side blade frame cutting knives.

See Changing Blades - Power Feed Slicer.

Using a screwdriver and a 3/8-inch wrench, remove the four screws and nuts holding chute guard in place under gravity infeed chute. See Figure 20. This will provide access for removing capscrews holding the infeed side blade frame feet to the rocker shaft.

Remove the infeed side blade frame in the same manner as the discharge side blade frame.

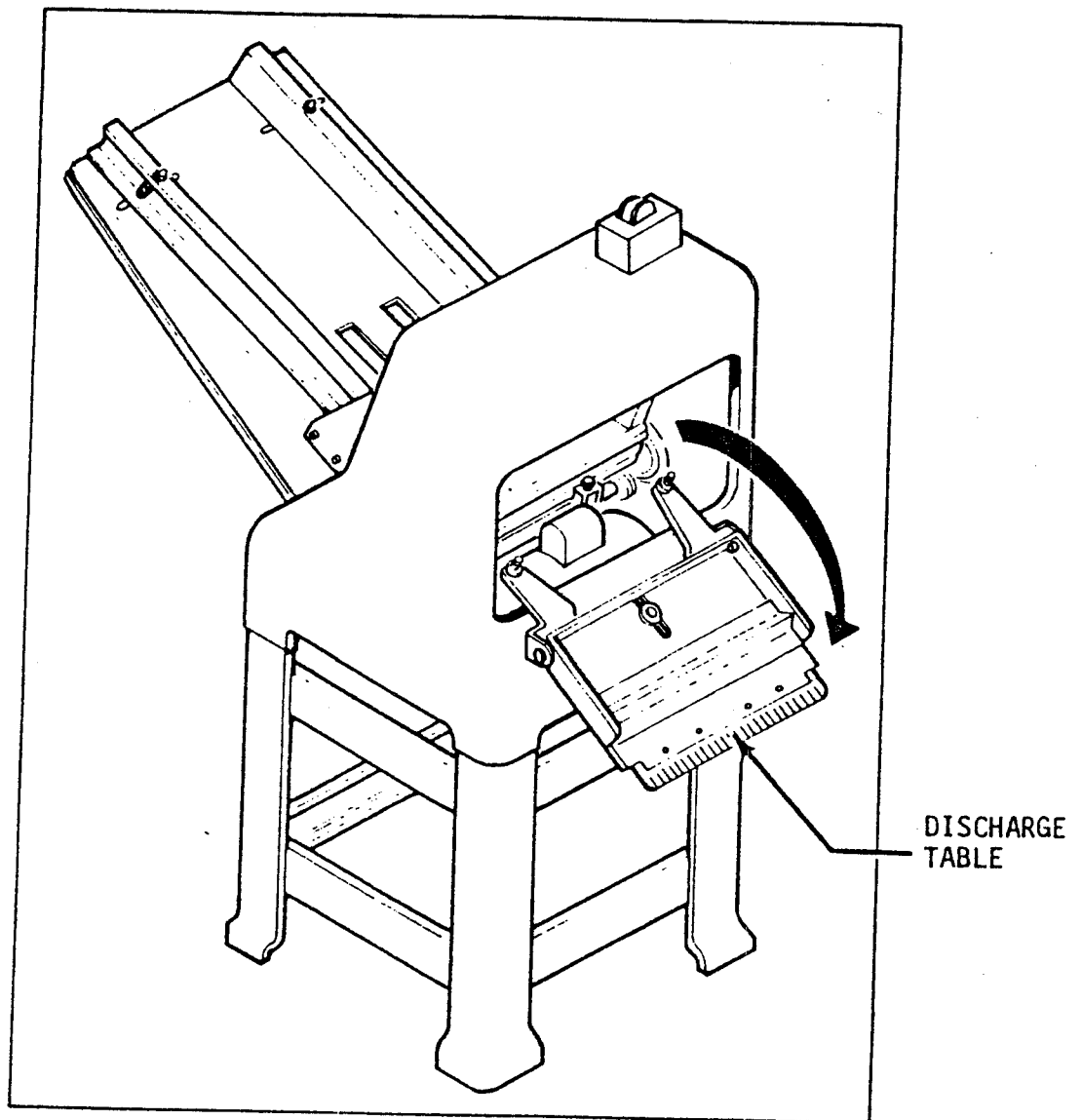

Figure 16. Swing Discharge Table Out

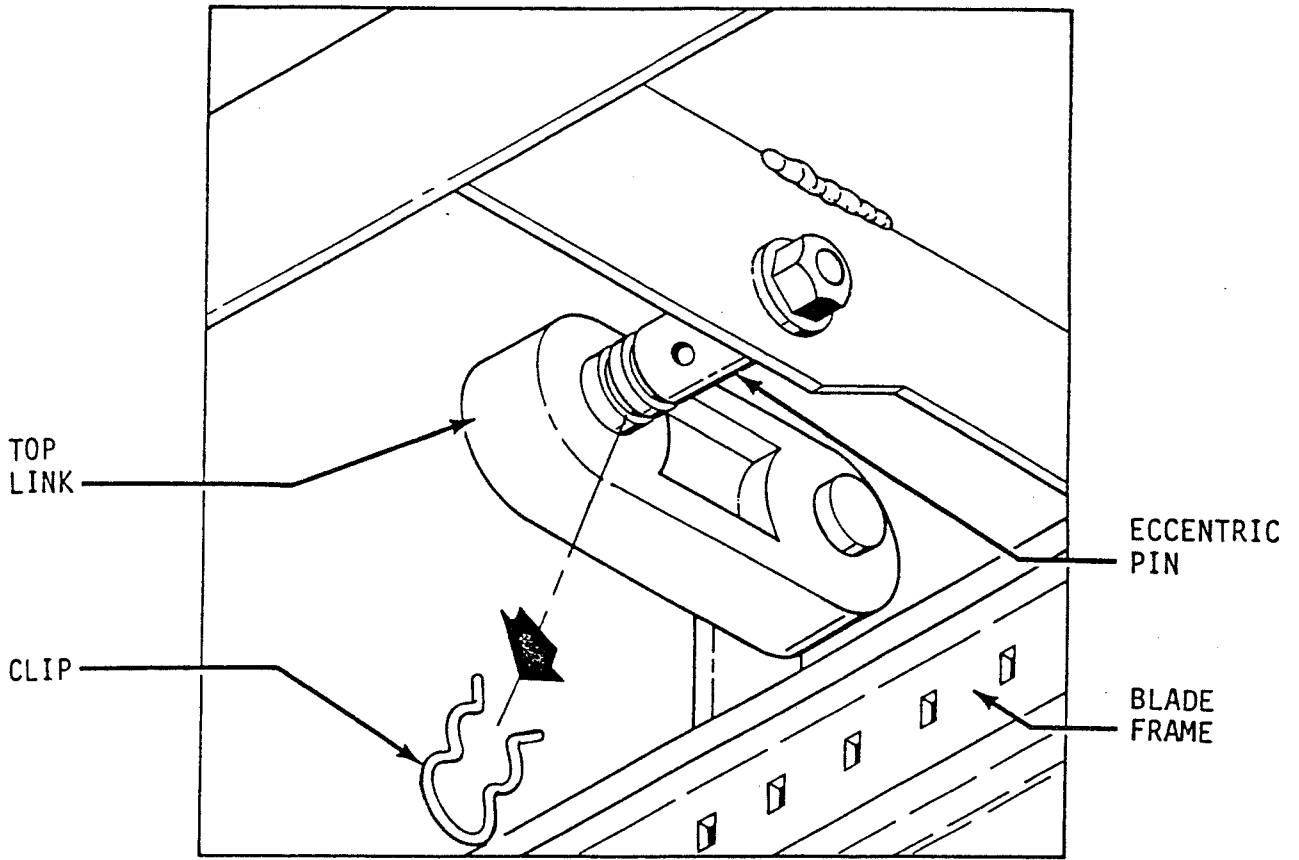

Figure 17. Removing Clip From Eccentric Pin

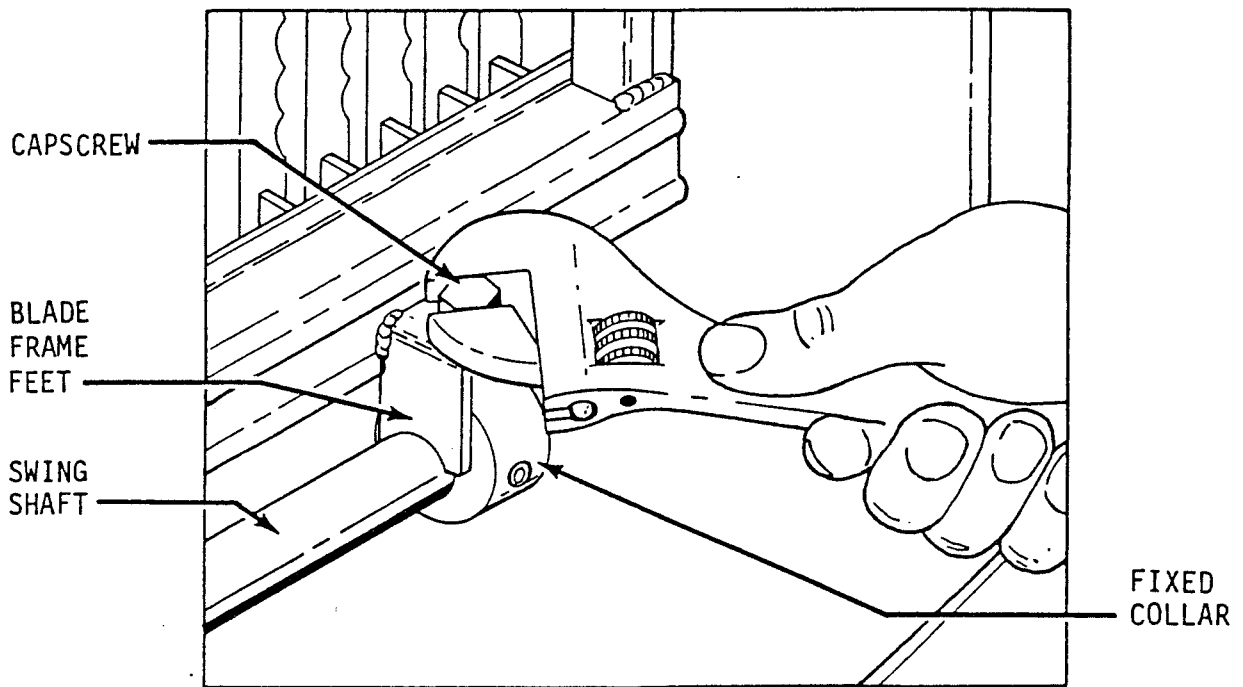

Figure 18. Removing Capscrews Securing Blade Frames

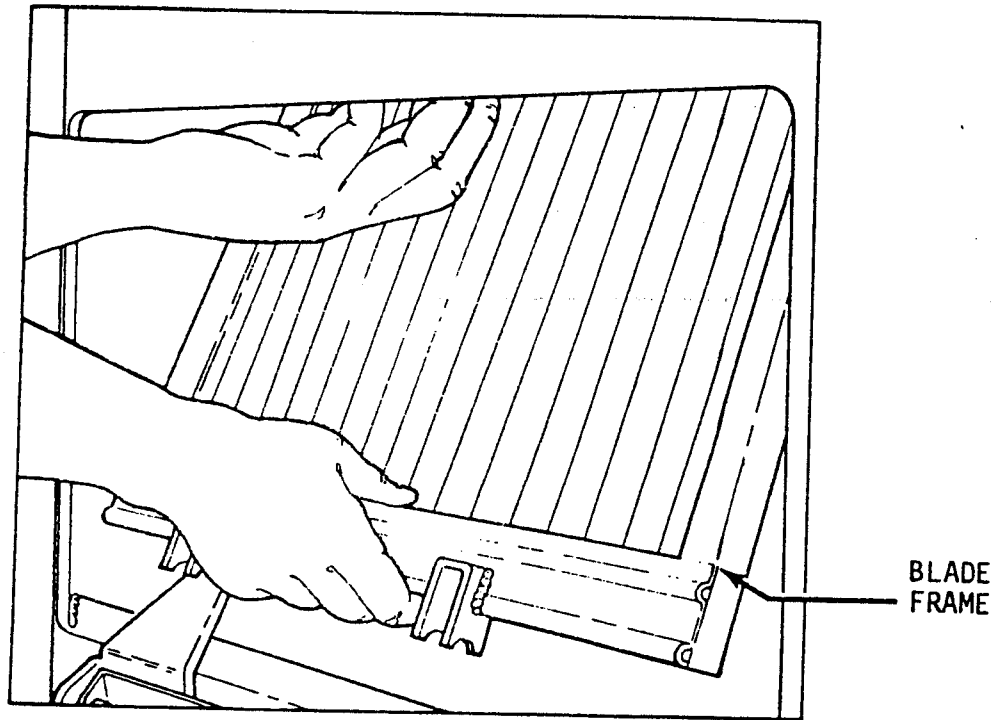

Figure 19. Removing Blade Frames

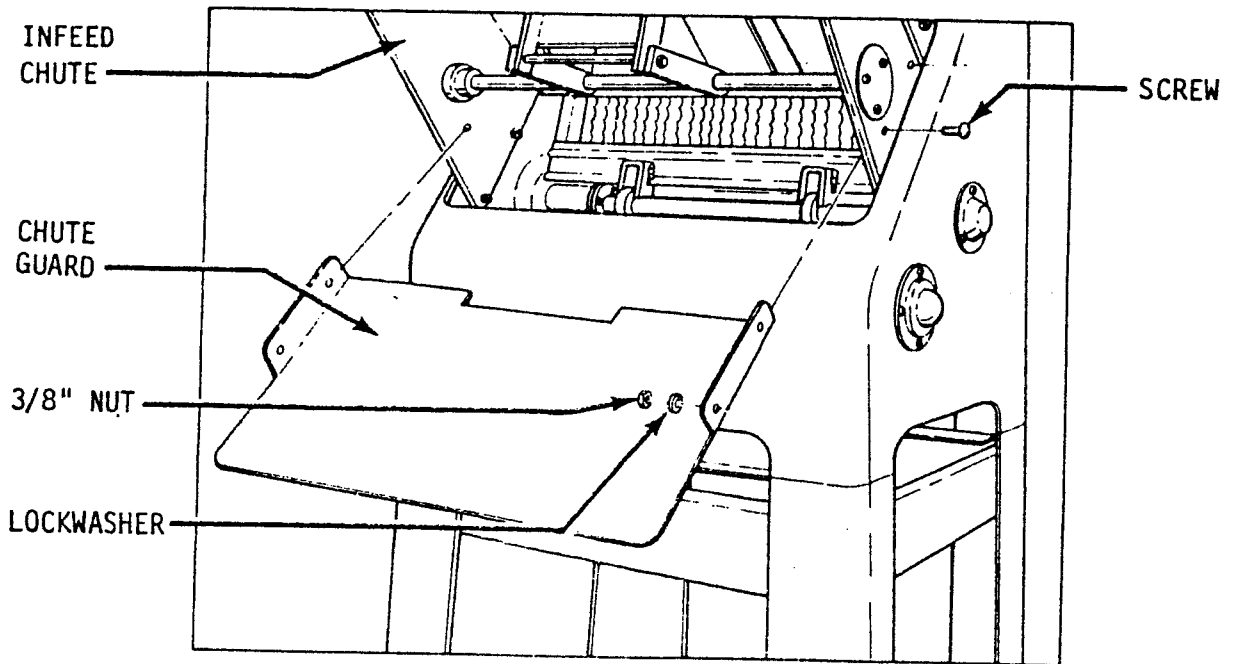

Figure 20. Removing Chute Guard

REMOVING BLADE FRAMES FROM SPRING FEED SLICER

Loosen the four knobs which lock infeed and discharge tables in place. Swing tables out of slicer to allow access to blade frames. See Figure 21. Remove the blade frames in the same manner as described for the Gravity Feed Slicer. (Refer to Figures 17, 18, and 19.)

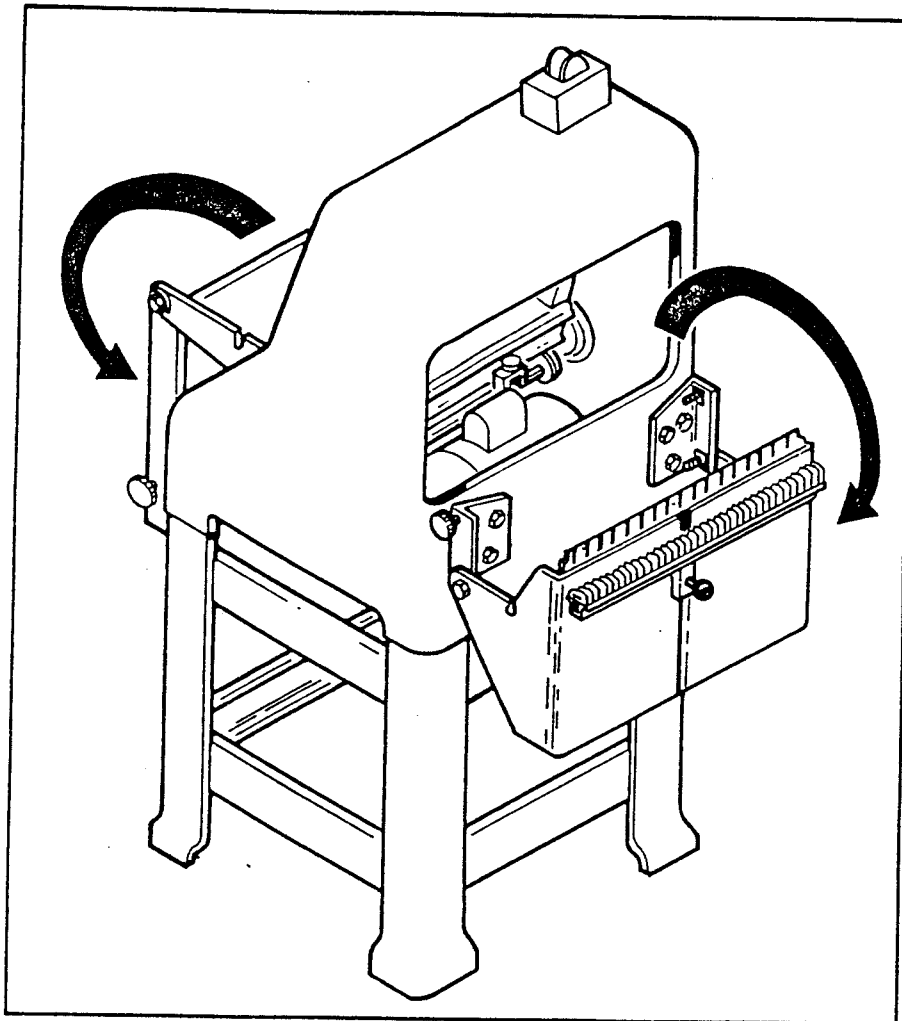

Figure 21. Swing Out Tables From Spring Feed Slicer

REPLACING BLADE FRAMES - ALL MODELS

To replace the blade frames, reverse the removal procedure. Ensure that the feet of the blade frames rest snugly on the swing shafts. Tighten capscrews at feet securely with a wrench. Top links must be attached to the blade frames with clips back in position.

CHANGING CUTTING KNIVES

WARNING

Cutting knives are extremely sharp. Always handle knives with care.

Place blade frame on a flat surface. Insert the special knife tool into blade holder. See Figure 22. Lifting up on the knife tool will deflect upper blade mount reducing tension on the cutting knife. Carefully remove the cutting knife from the blade mount.

NOTE

Since the power feed slicer infeed side blade frame cannot be easily removed, a special tool has been provided to allow removal of cutting knives from blade frame while still in the slicer. The cutting knives are changed in the same manner as used to change cutting knives outside of the slicer.

Reverse the procedure to install replacement cutting knife. A paper clip can be used to hold cutting knife in position on lower blade mount during cutting knife installation. See Figure 23.

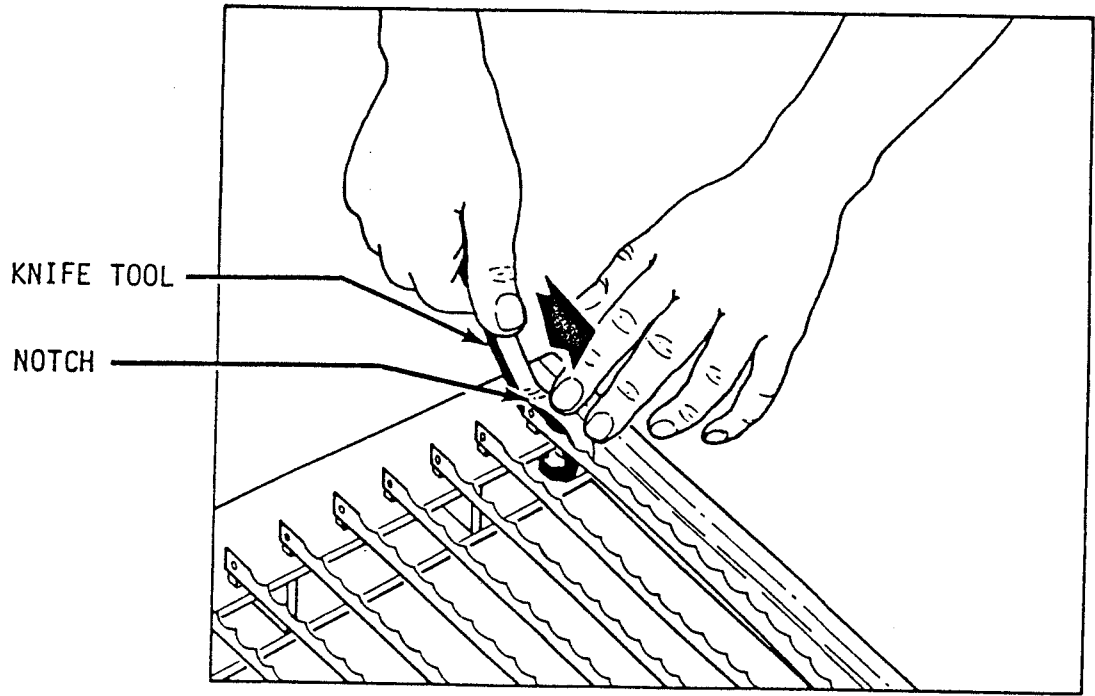

Figure 22. Blade Removal Using Knife Tool

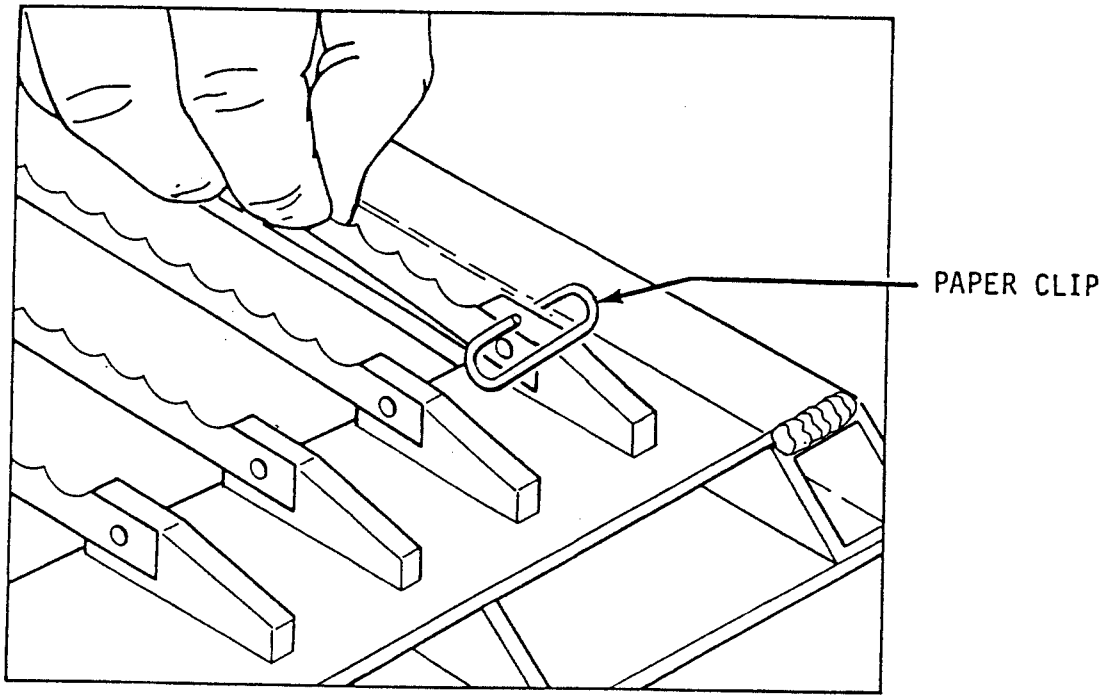

Figure 23. Cutting Knife Installation

NOTE

When replacing all the cutting knives, always remove the center cutting knives first and work towards the ends. Install the new cutting knives at the ends first and work alternately towards the center.

CAUTION

Never put blade frames in the slicer without cutting knives installed.

TIGHTENING BELT

CAUTION

Overtightening the drive belt may cause bearing or motor failure.

Remove crumb tray from slicer and swing out discharge table. Loosen lockbolt located below belt adjustment mechanism. See Figure 24. Locate adjustment bolt below belt. See Figure 25. Turn adjustment nut counterclockwise with a wrench to increase tension on drive belt. To reduce tension, turn adjustment nut clockwise. Drive belt should be just tight enough, using moderate finger pressure, to allow a 3/8-inch deflection halfway between the motor drive pulley and the driven pulley. Retighten lockbolt.

REPLACING BELT

Remove crumb tray and swing out discharge table. (Refer to Figure 24.) Locate adjustment bolt below drive belt. (Refer to Figure 25.) Turn adjustment bolt clockwise with a wrench to loosen drive belt. Disconnect end of

connecting rod at rocker frame by removing two capscrews and cap. See Figure 26. Remove drive belt from pulleys. Install new drive belt by reversing the removal procedure. Refer to Tightening Belt section to adjust drive belt tension.

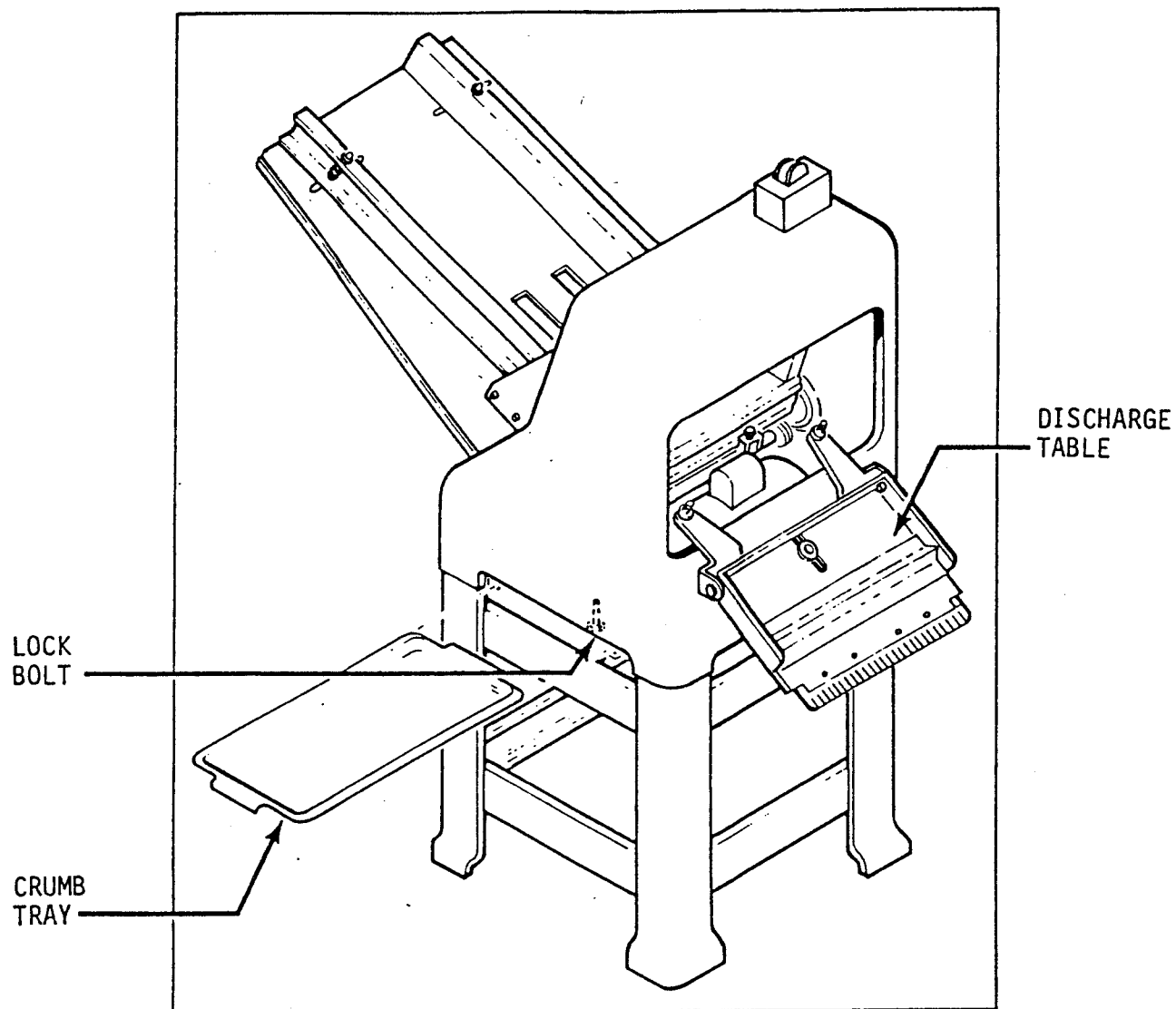

Figure 24. Removing Discharge Table and Crumb Tray

TRACKING POWER FEED INFEED BELT

Loosen the lockbolts on each side of the infeed chute. See Figure 27. Locate the infeed belt tensioning screws at the top of infeed chute. The infeed belt will tend to drift towards the loose side of the belt. If the infeed belt drifts to one side, tighten that side by turning the adjustment screw counterclockwise or by loosening the opposite (tight) side by turning the adjustment screw clockwise.

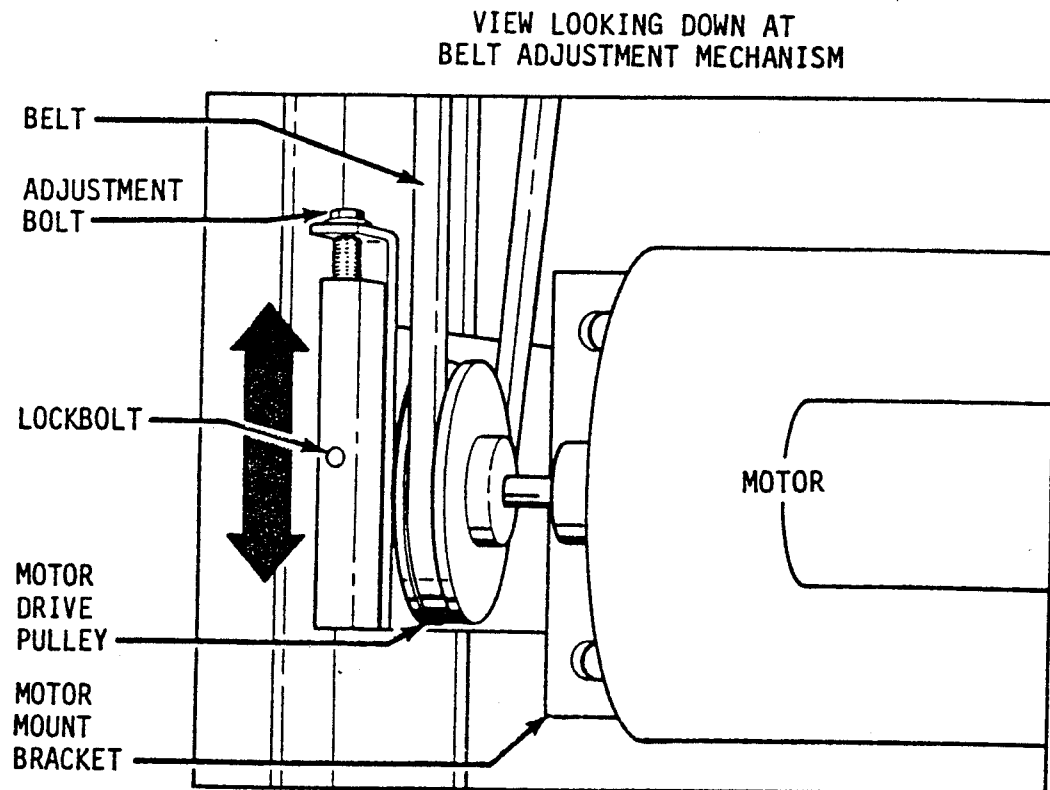

Figure 25. Adjusting Drive Belt

REPLACING INFEEED BELT ON POWER FEED SLICERS

Remove lower chute guard and loosen lockbolts. See Figure 27. Turn tensioning screws clockwise to loosen the belt. To ease reassembly, remove the idler roll (center roller) by removing the acorn nuts from the ends of its shaft and sliding it out.

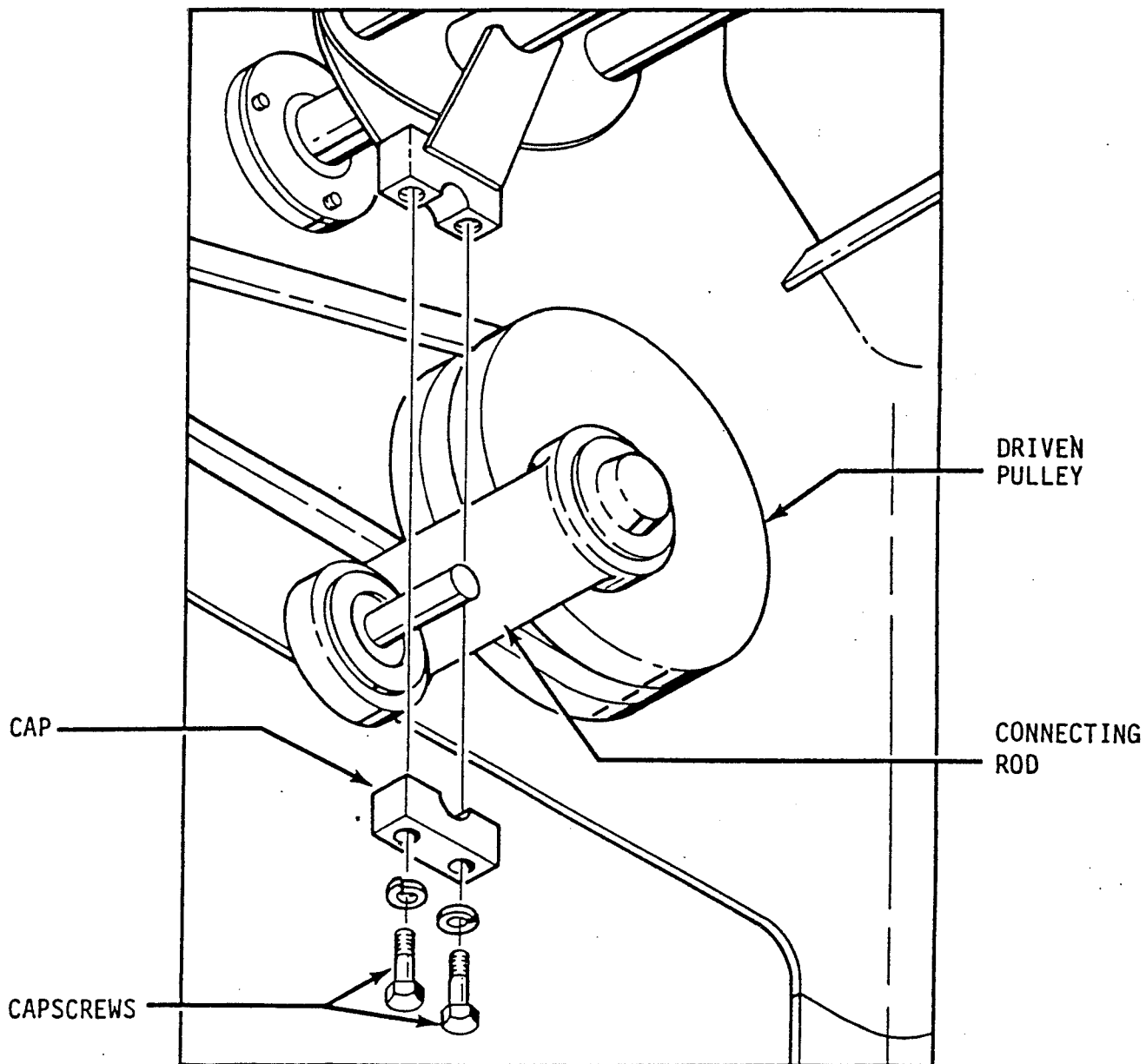

Figure 26. Removing Connecting Rod

The belt itself may now be removed by removing the pin from the lacing of the belt with a pair of pliers, allowing the belt to separate. The belt can now be lifted from the machine.

Install the new belt by joining the ends together and inserting the pin into the lacing. Reinstall the idler roller by reversing its removal procedure. Track the belt as described above. Replace lower chute guard, being sure to tighten all screws and lockbolts.

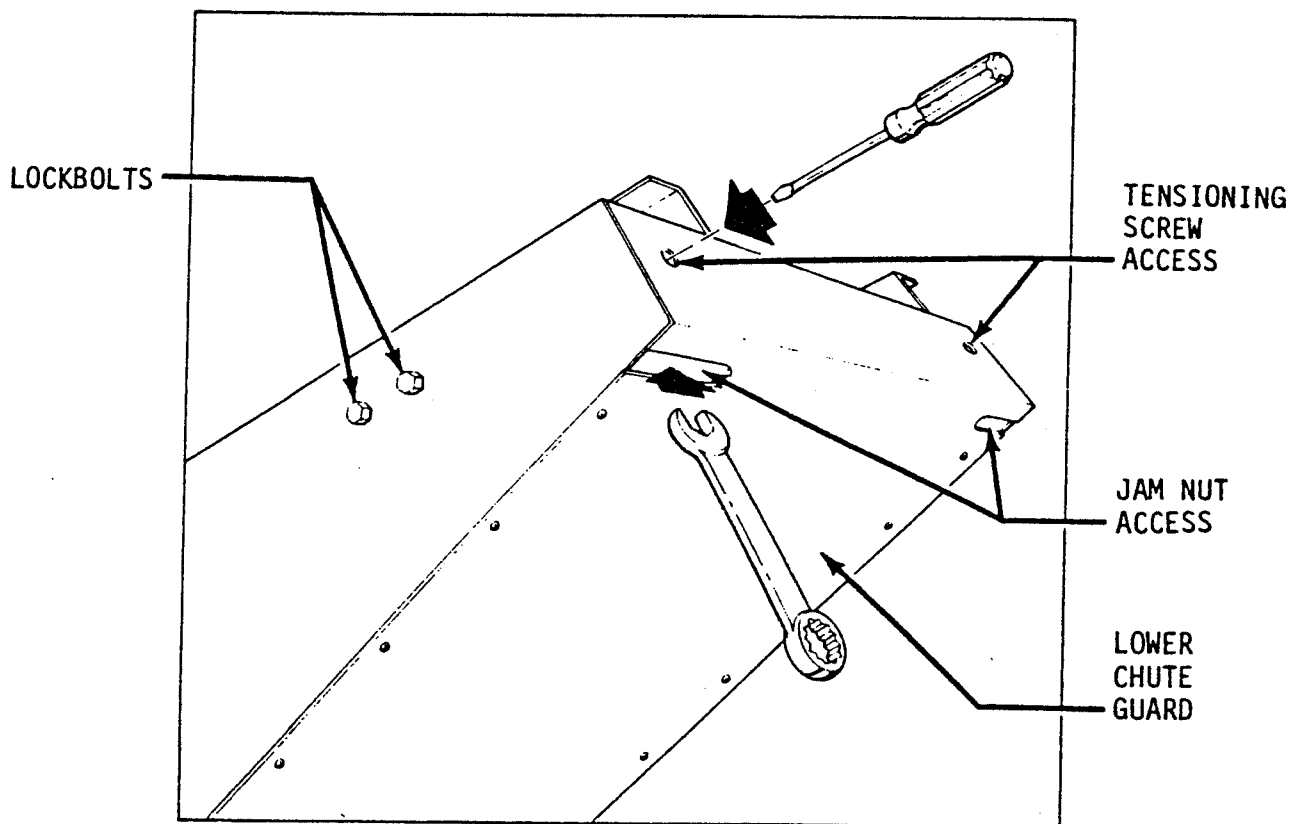

Figure 27. Adjusting Power Feed Belt Tracking

LUBRICATION

Once a month put a drop of a food approved lubricant on the four bushings at the top links above blade frames. All other bearings are grease packed and seldom need attention.

CAUTION

Never oil or grease the motor.

CLEANING

CLEANING GRAVITY FEED OR POWER FEED SLICERS

Swing out the discharge table to allow access for brushing off crumbs found on the working parts of the slicer. (Refer to Figure 24.) Slicer should be cleaned and crumb tray emptied on a regular basis as needed.

CLEANING SPRING FEED SLICERS

Swing out the discharge and infeed tables to allow access for brushing off crumbs found on the working parts of the slicer. (Refer to Figure 21.) Slicer should be cleaned and crumb tray emptied on a regular basis as needed.

BLADE FRAME ADJUSTMENT

SLICES VARY IN THICKNESS

Swing out discharge table from the slicer. With a wrench loosen, but do not remove, hex head capscrews in feet of blade frame adjacent to discharge table. Using an allen wrench, loosen setscrew in rocker frame fixed collar. Using a ruler (20 inch maximum) measure the distance between the cutting knives. See Figure 28. Gently tap the fixed collar to the right or left with a small hammer until the distances between cutting knives are equally spaced. Tighten setscrew and capscrews in blade feet.

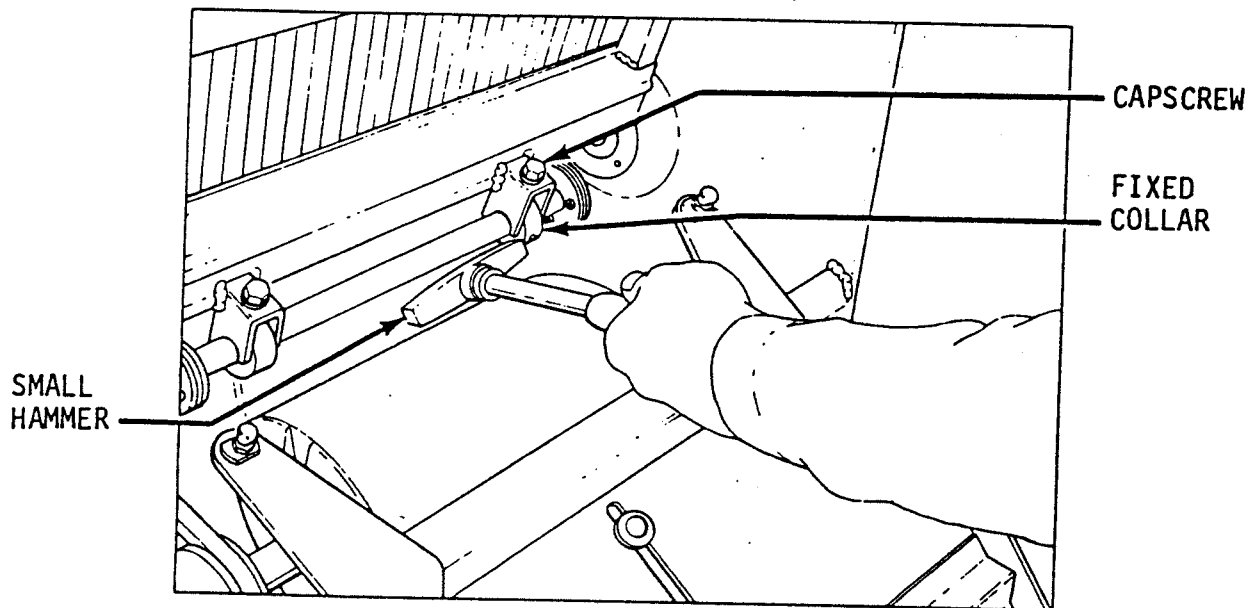

Figure 28. Adjusting Slice Thickness

BLADE FRAME CLEARANCE ADJUSTMENT

The distance between the blade frames is adjusted by rotating the eccentric pins located above the blade frames. The eccentric pin is set off center to its threaded end. By rotating the pin its center point is changed in relation to its mounting point. A small screwdriver or rod must be inserted through the hole in the side of the eccentric pin to keep the pin from rotating while loosening locknut on the end of the pin with a wrench. See Figure 29.

Using a small screwdriver or rod, rotate pin to the desired position and tighten the locknut to hold pin in place. Check blade frame clearance by turning driven pulley by hand.

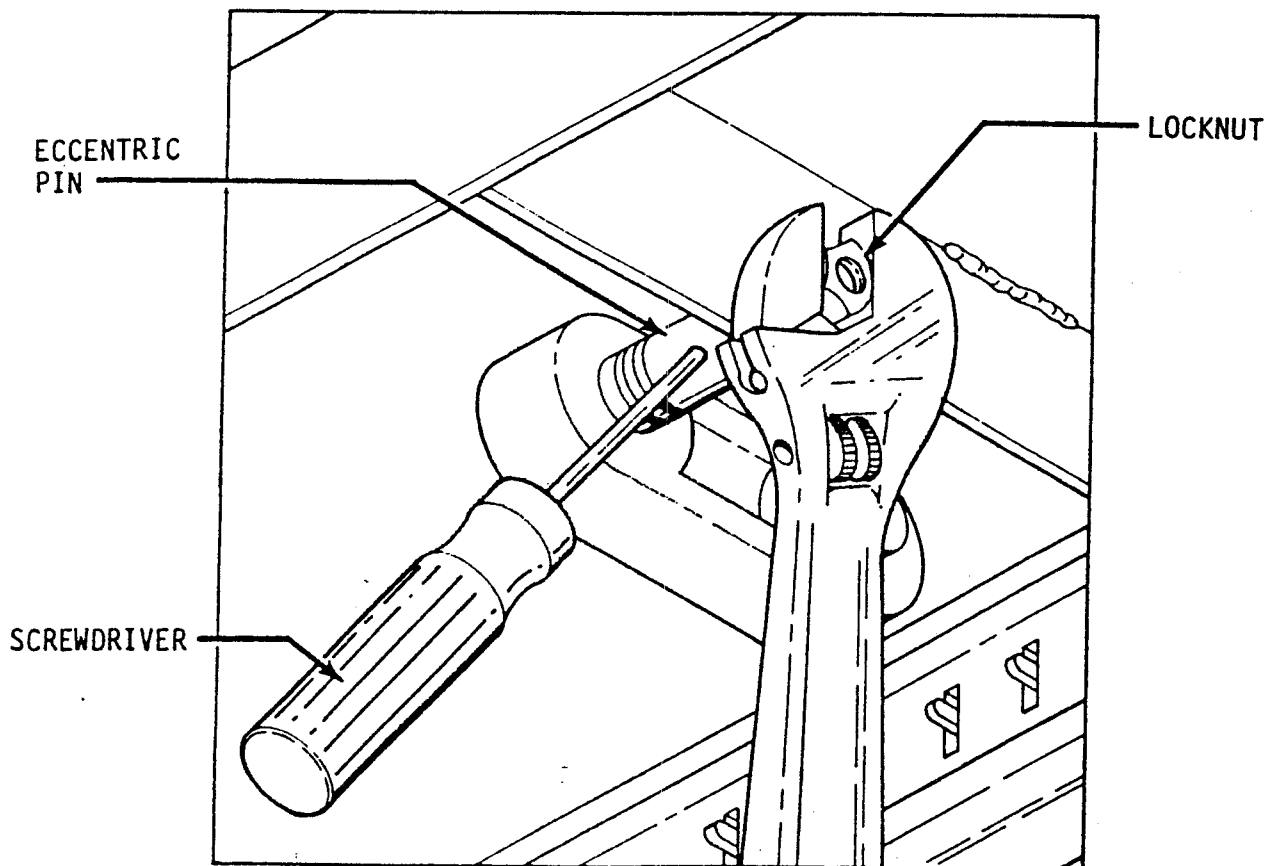

Figure 29. Adjusting Blade Frames Using Eccentric Pins

TROUBLESHOOTING

TROUBLESHOOTING GUIDE

WARNING

ALWAYS UNPLUG SLICER WHEN ADJUSTING OR REPAIRING.

PROBLEM	PROBABLE CAUSE(S)	REMEDY
BREAD SLICES VARY IN THICKNESS	Blade frames out of adjustment.	Adjust blade frames and fixed collar. (See Page 32.)
BLADE FRAMES KNOCKING	Not enough clearance between frames.	Adjust eccentric pins. (See Page 33.)
SWITCHES TURNED ON, MOTOR HUMS BUT WILL NOT START (SEE CAUTION)	Motor or drive system binding (defective bearings).	Replace or repair.
	Interference between parts of slicer mechanism.	Adjust or repair.

CAUTION

Do not allow motor to hum without starting as this will damage the motor causing it to overheat.

TROUBLESHOOTING GUIDE (Continued)

PROBLEM	PROBABLE CAUSE(S)	REMEDY
SWITCHES TURNED ON, BUT MOTOR DOES NOT START OR HUM	No power at outlet. (Check by plugging lamp or appliance into outlet.)	Repair outlet or circuit.
	Motor switch overload tripped.	Reset following instructions on switch nameplate.
	Bread crumbs in motor starting switch.	Switch should be disassembled and cleaned by a qualified person.
SLICER VIBRATES EXCESSIVELY	Top links or bearings worn.	Locate worn parts and replace.

NOTE

A special non-ventilated motor must be used with the slicer.

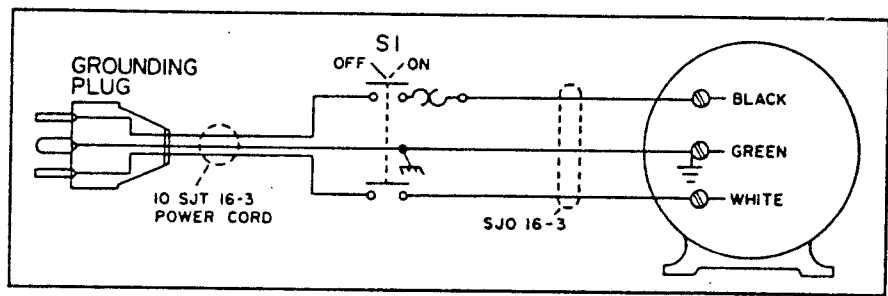
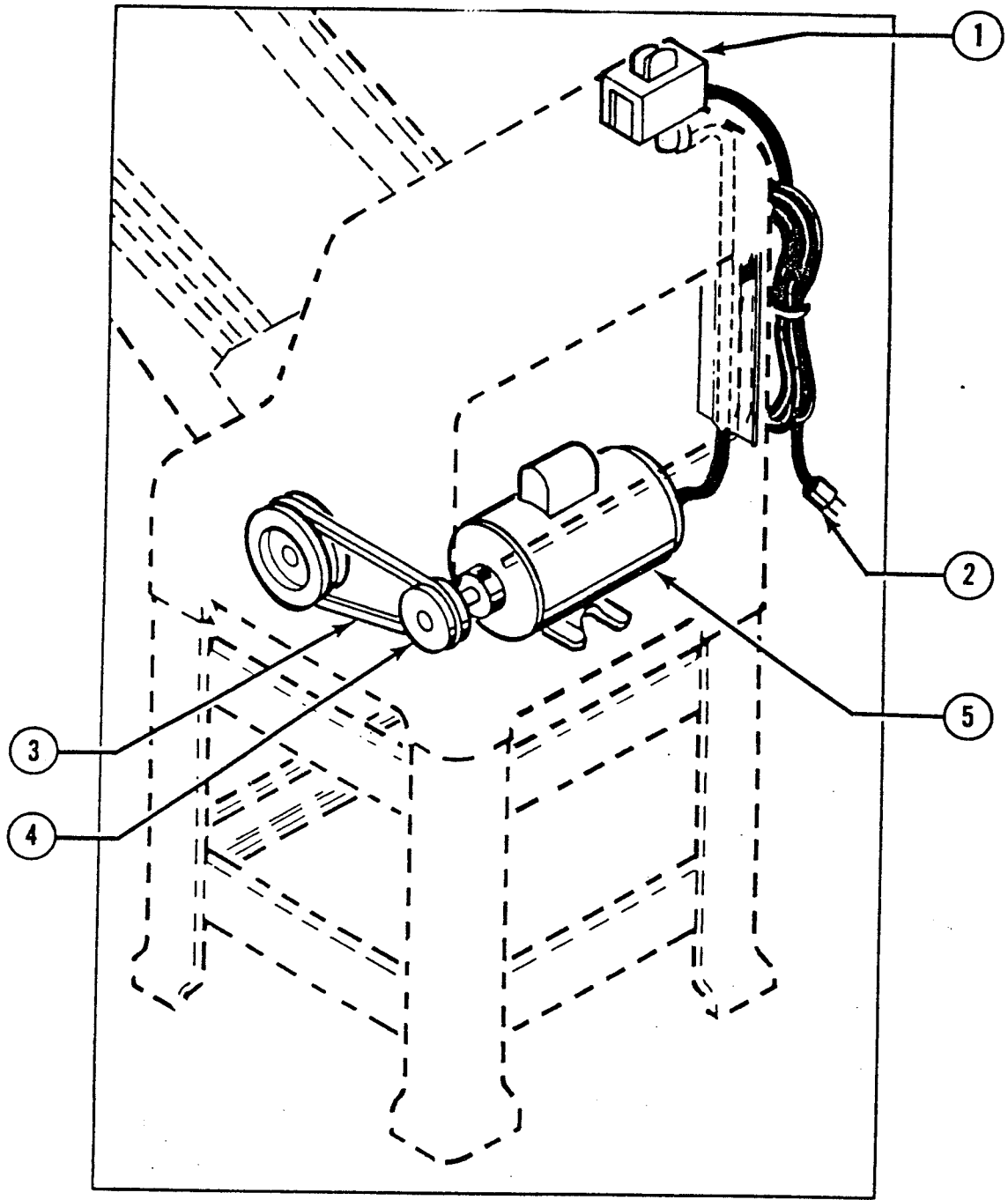

Figure 30. Single Phase Gravity or Power Feed Wiring Diagram

ELECTRICAL COMPONENTS PARTS LIST

SINGLE PHASE - GRAVITY OR POWER FEED SLICERS

(See Figure 30)

1/2 HP, 1-60-115/230, (48" Gravity & 48" Power)

ITEM NO.	PART NO.	DESCRIPTION	QUANTITY
1	5709-1137	SWITCH, Starter	1
1	0797-2131	COVER, Switch	1
1	5757-4815	BOOT	1
2	0777-1040	CORD, Plug	1
3	5601-1966	BELT, V - 4L36-1/2	1
4	5615-9046	PULLEY, Motor	1
5	6301-3609	MOTOR	1

1/2 HP, 1-50-110/220, (48" Gravity & 48" Power)

ITEM NO.	PART NUMBER	DESCRIPTION	QUANTITY
1	5709-1137	SWITCH, Starter	1
1	0797-2131	COVER, Switch	1
1	5757-4815	BOOT	1
2	0777-1040	CORD, Plug (Plug cut off)	1
3	5601-1969	BELT, V - XDV48-:380	1
4	5615-1015	PULLEY, Motor	1
5	6301-3940	MOTOR	1

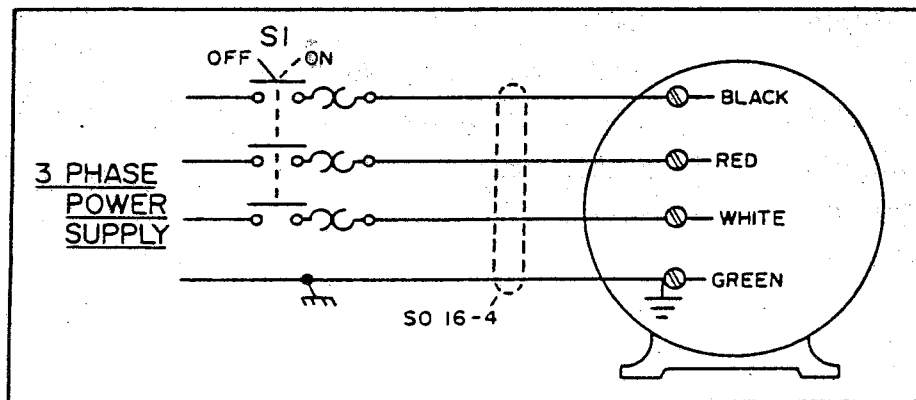
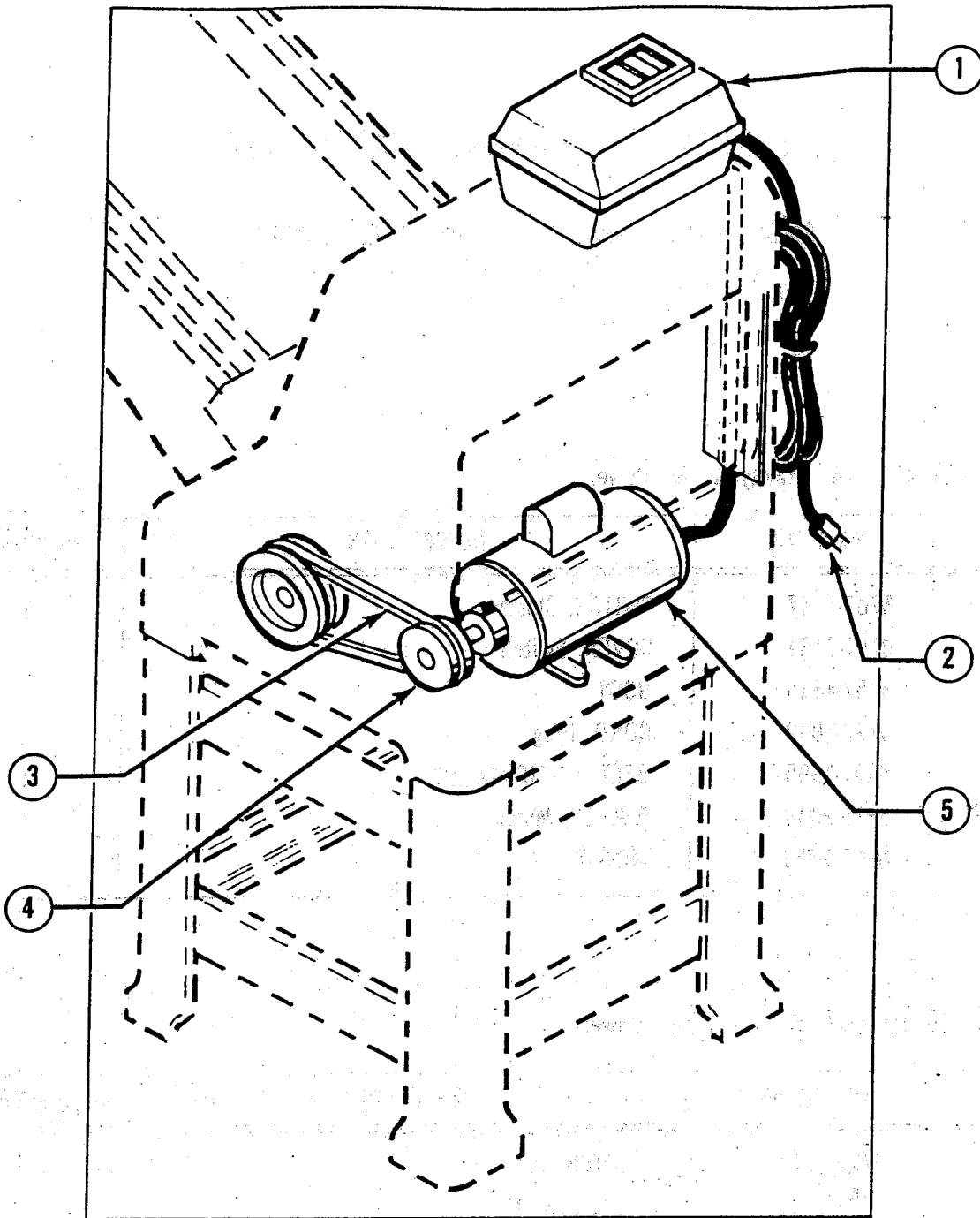

Figure 31. 3 Phase Gravity or Power Feed Wiring Diagram

3 PHASE - GRAVITY OR POWER FEED SLICERS

(See Figure 31)

1/2 HP, 3-60-230/460, (48" Gravity & 48" Power)

ITEM NO.	PART NO.	DESCRIPTION	QUANTITY
1	5709-3034	SWITCH, Starter	1
2	5765-8305	CORD, Plug - 16/4 SJO	10 Ft
3	5601-1966	BELT, V - 4L36-1/2	1
4	5615-9046	PULLEY, Motor	1
5	6301-3800	MOTOR	1

1/2 HP, 3-60-208, (48" Gravity & 48" Power).

ITEM NO.	PART NO.	DESCRIPTION	QUANTITY
1	5709-3034	SWITCH, Starter	1
2	5765-8305	CORD, 16/4 SJO	10 Ft.
3	5601-1966	BELT, V - 4L36-1/2	1
4	5615-9046	PULLEY, Motor	1
5	6301-3811	MOTOR	1

1/2 HP, 3-50-220/415/440, (48" Gravity & 48" Power)

ITEM NO.	PART NO.	DESCRIPTION	QUANTITY
1	5709-3034	SWITCH, Starter	1
2	5765-8305	CORD, 16/4 SJO	10 Ft.
3	5601-1969	BELT, V - XDV48-380	1
4	5615-1015	PULLEY, Motor	1
5	6301-3811	MOTOR	1

3 PHASE - GRAVITY OR POWER FEED SLICERS (Continued)

1/2 HP, 3-50-380, (48" Gravity & 48" Power)

ITEM NO.	PART NO.	DESCRIPTION	QUANTITY
1	5709-3034	SWITCH, Starter	1
2	5765-8305	CORD, 16/4 SJO	10 Ft.
3	5601-1969	BELT, V - XDV48-380	1
4	5615-1015	PULLEY, Motor	1
5	6301-3975	MOTOR	1

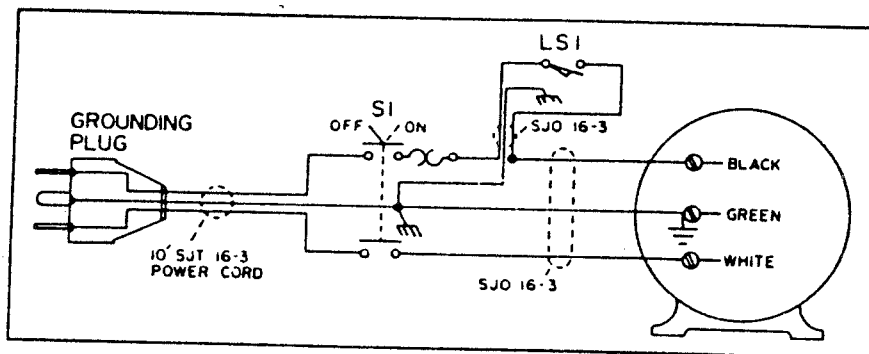
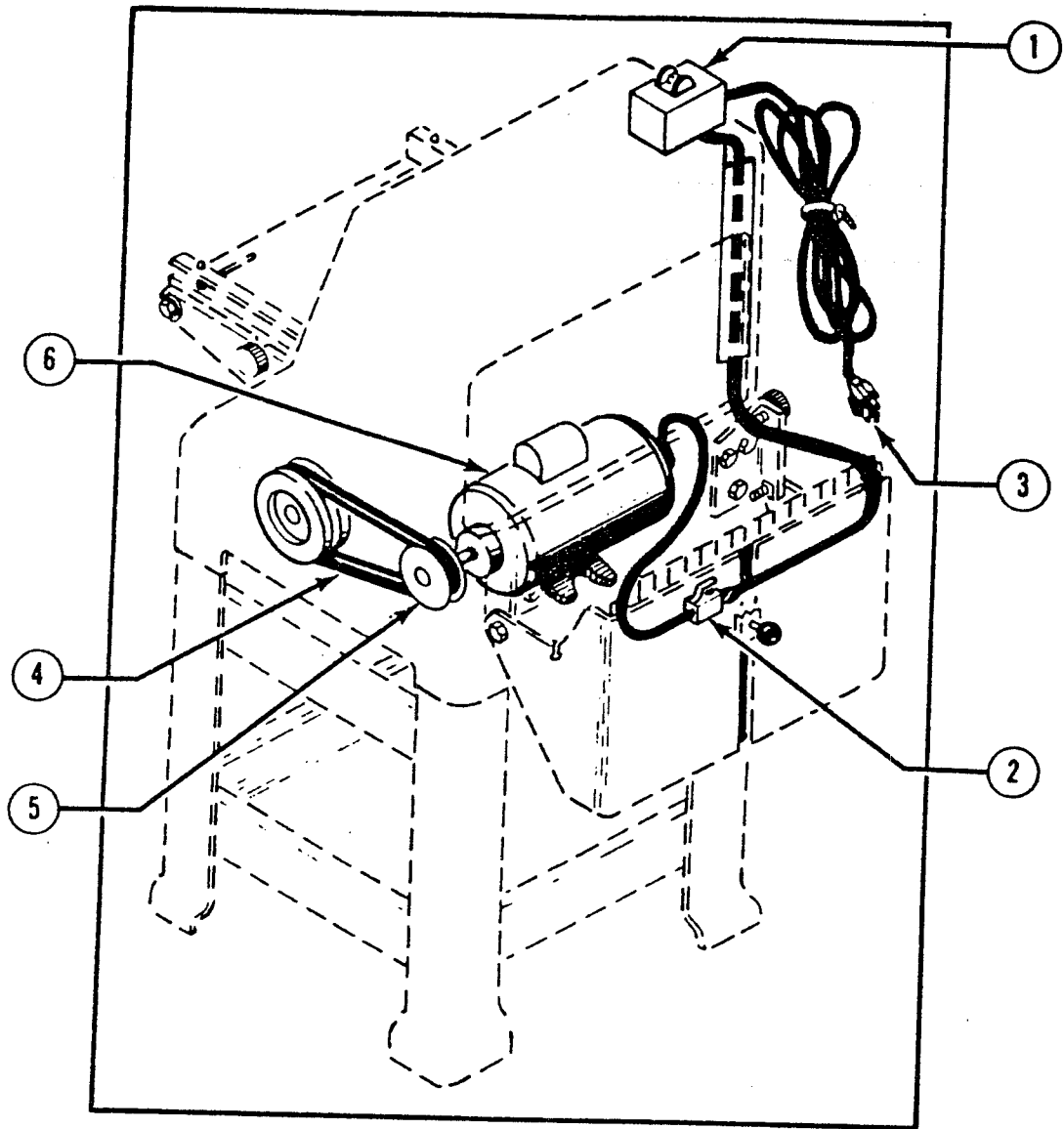

Figure 32. Single Phase Spring Feed Wiring Diagram

SINGLE PHASE - SPRING FEED SLICERS

(See Figure 32)

1/2 HP, 1-60-115/230, High Speed

ITEM NO.	PART NO.	DESCRIPTION	QUANTITY
1	5709-1137	SWITCH, Starter	1
1	0797-2131	COVER, Switch	1
1	5757-4815	BOOT	1
2	5757-8085	SWITCH, Micro	1
3	0777-1040	CORD, Plug (Plug cut off)	1
4	5601-1966	BELT, V - 4L36-1/2	1
5	5615-9046	PULLEY, Motor	1
6	6301-3609	MOTOR	1

1/2 HP, 1-50-110/220, High Speed

ITEM NO.	PART NUMBER	DESCRIPTION	QUANTITY
1	5709-1137	SWITCH, Starter	1
1	0797-2131	COVER, Switch	1
1	5757-4815	BOOT	1
2	5757-8085	SWITCH, Micro	1
3	0777-1040	CORD, Plug (Plug cut off)	1
4	5601-1969	BELT, V - XDV48-380	1
5	5615-1015	PULLEY, Motor	1
6	6301-3940	MOTOR	1

RECOMMENDED SPARE PARTS

NO. REQUIRED	PART NUMBER	DESCRIPTION
4	5835-7705	CLIP, Hairpin
4	0777-0034	PIN, Eccentric
4	0797-0059-2	STUD & NUT
4	0711-0002	LINK, Top
1	5601-1966	BELT, V (60 CY)
1	5601-1969	BELT, V (50 CY)
1	5709-1137	SWITCH, Starter (Single Phase)
1	5220-5030	BEARING,. Driven Pulley
1	5220-5001	BEARING, Driven Pulley
1	0797-3134	STUD, Driven Pulley
1	6904-6001	GASKET, Driven Pulley
1	0797-0271-001	ROD, Connecting
1	5220-2600	BEARING, Connecting Rod
1	5230-4010	BEARING, Connecting Rod
1	0797-0057-2	STUD, Swing
1	5220-4000	BEARING, Rocker Shaft
1	5220-4050	BEARING, Rocker Shaft
4	5220-0020	BEARING, Swing Shaft
3	6904-6000	GASKET, Rocker Shaft
1	6301-3609	*MOTOR, 1/2 HP, 1-60-115/230
1	5757-8065	SWITCH-TABLE (Spring Feed)
1	5757-4815	BOOT

*For Other Motors, Contact Factory

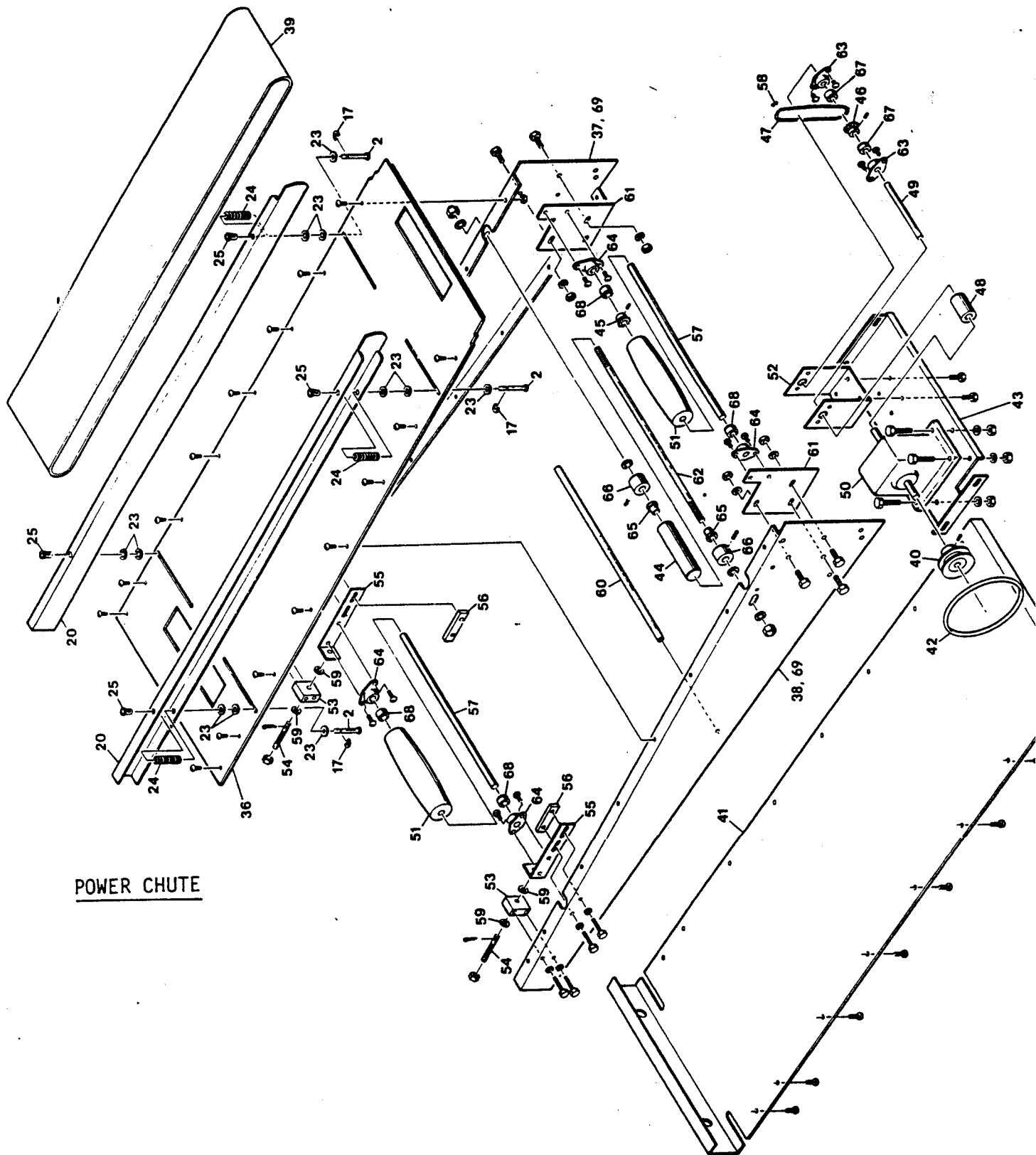

POWER CHUTE

Figure 33. Slicer Chute Assemblies

GRAVITY CHUTE

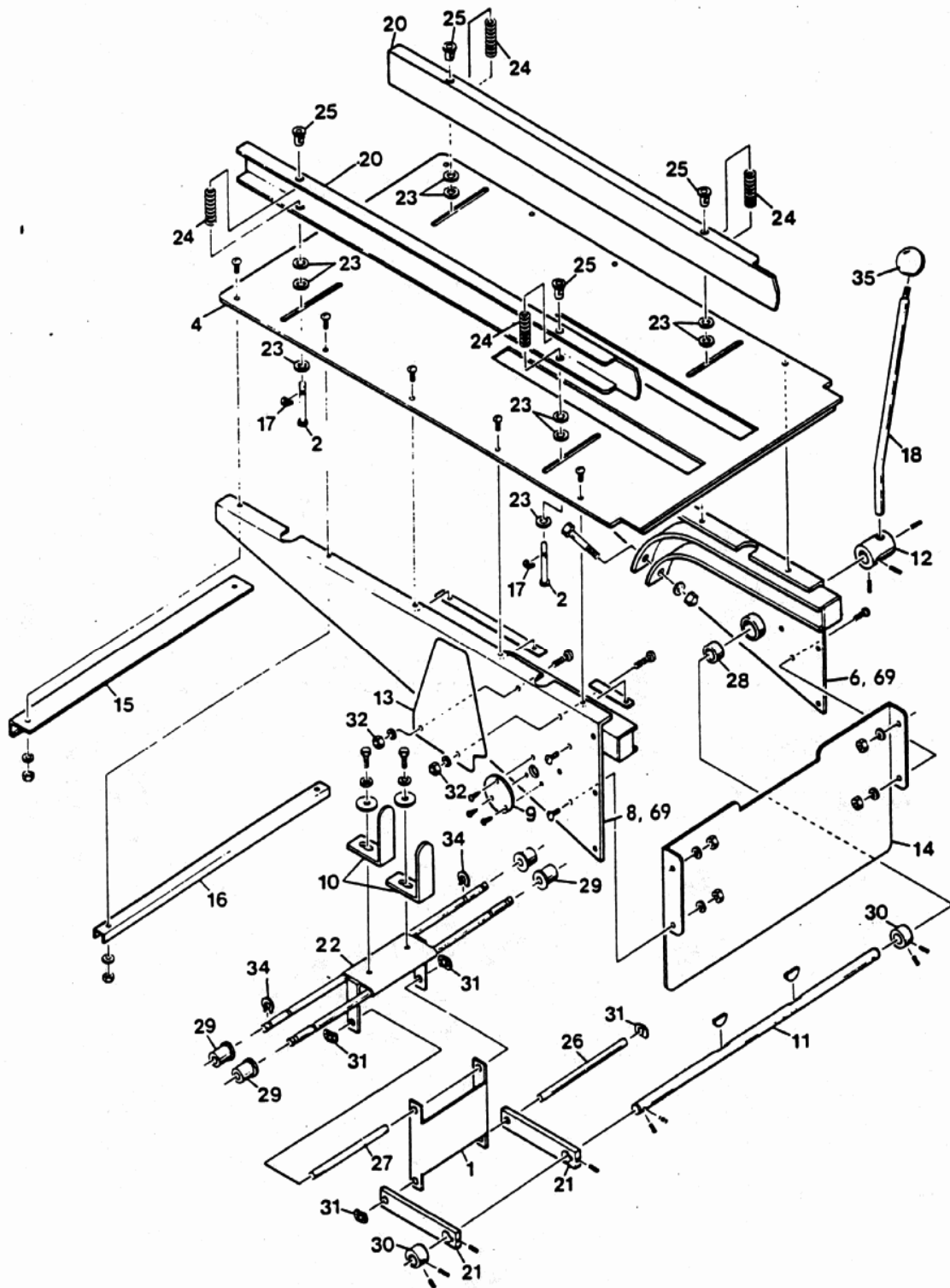

Figure 33. Slicer Chute Assemblies

MECHANICAL PARTS LIST

Figure 33 CHUTE ASSEMBLY

FIGURE & ITEM NO.	PART NUMBER	DESCRIPTION	QUANTITY
1	0797-3062	LINK, Pusher	1
2	0797-3011-002	PIN, Side Guide	4
4	0797-3008-01	CHUTE, Bread Top, 48"	1
6	0797-2088-0012	BRACE, L.H. Chute, 48"	1
8	0797-2088-0011	BRACE, R.H. Chute, 48"	1
9	0797-2080	CAP, Chute Brace	1
10	0797-2077	FINGER, Pusher	2
11	0797-2076-001	CROSS, Shaft Pusher	1
12	0797-3070	HUB, Pusher Lever	1
13	0797-0947	GUARD, Chute Crotch	2
14	0797-0915-003	GUARD, Chute	1
15	0797-0237-101	BRACE, Chute Top	1
16	0797-0415-1	BRACE, Chute End, 48"	3
17	0793-0084	WASHER, Horseshoe	8
18	0777-0915	LEVER, Pusher	1
20	0797-3010-001	SIDE GUIDE, 48"	2
21	0797-3064	BAR, Pusher	2
22	0797-3063-001	CARRIAGE, Pusher	1
23	5851-8120	WASHER, Nylon	12
24	7012-3102	SPRING, (#97)	4
25	5765-1058	BUSHING, Snap	4
26	4565-0508-0063	SHAFT	1
27	4565-0508-0058	SHAFT	1
28	5254-0300	BEARING, Bronze	2
29	5504-1700	WHEEL, Carriage	4
30	5806-7012	COLLAR, Set, 3/4"	2

NOTE: Some items may not be exactly as shown on drawing.

MECHANICAL PARTS LIST, CON'T

Figure 33 CHUTE ASSEMBLY

FIGURE & ITEM NO.	PART NUMBER	DESCRIPTION	QUANTITY
31	5831-8225	CLIP, Push-On	4
32	5832-0585	NUT, Acorn #10-24	4
34	5840-1125	RING, Retaining	4
35	5911-7002	KNOB, Ball	1
36	0797-3008-009	CHUTE, Bread Top	1
37	0797-3009-0012	CHUTE, L.H., Power	1
38	0797-3009-0011	CHUTE, R.H., Power	1
39	5600-9468	BELT	1
40	0797-3379	PULLEY	1
41	0797-3047	PAN, Chute Bottom	1
42	0797-3133	BELT	1
43	0797-3046-1	SUPPORT, Channel Reducer	1
44	0883-0227-033	ROLL	1
45	4618-3510-2001	SPROCKET	1
46	5616-6041	SPROCKET	1
47	5603-1003	CHAIN, Roller	1
48	5604-6956	COUPLING, Flex Jaw	1
49	0797-3374	SHAFT	1
50	5607-3237	UNIT, Gear	1
51	0797-3402	PULLEY, Crowned	2
52	0797-3027	CHANNEL, Shaft	1
53	0797-3034	BLOCK, Adjusting	2
54	0797-3035	BOLT, Adjusting	2
55	0797-3036	ANGLE, Bearing	2
56	4460-1008-2012	BAR, Nut	2
57	0797-3372	SHAFT	2
58	5604-0100	LINK, Connector	1
59	5851-8140	WASHER	4
60	0797-0416	ROD, Brace	1
61	0797-3037	PLATE, Bearing	2

FIGURE & ITEM NO.	PART NUMBER	DESCRIPTION	QUANTITY
33 62	4625-1212-117	. STUD, Double End	1
63	5251-8045	. BEARING, Flange, 1/2"	2
64	5251-8046	. BEARING, Flange, 5/8"	4
65	5252-3030	. BEARING, Plastic	2
66	5806-7006	. COLLAR, Set, 3/8"	2
67	5806-7008	. COLLAR, Set, 1/2"	1
68	5806-7010	. COLLAR, Set, 5/8"	4
69	0797-2092	. SPACER; Chute (Not Shown)	2

NOTE: Some items may not be exactly as shown on drawing.

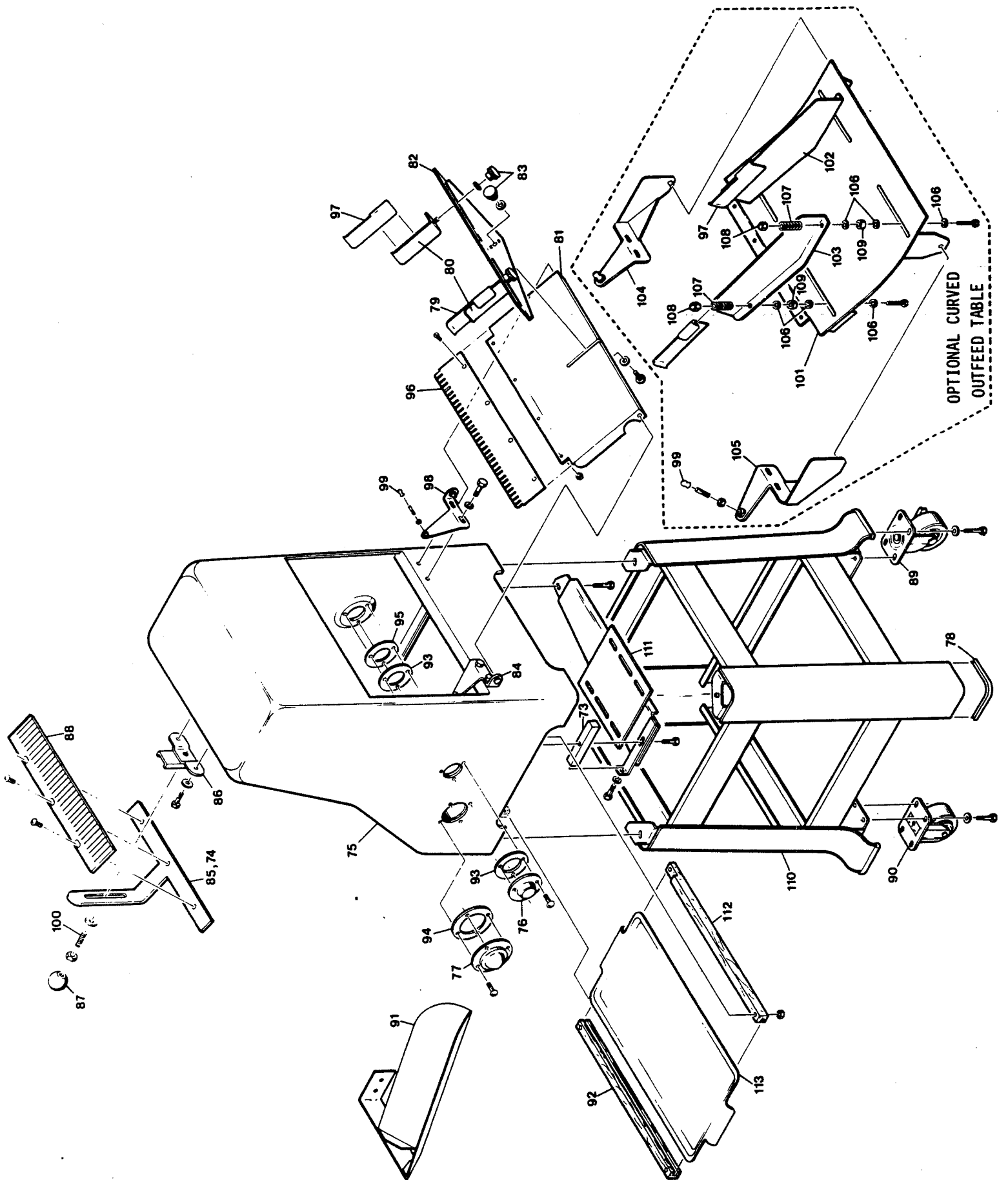

Figure 34. Slicer Frame Base Assembly and Optional Parts

FIGURE & ITEM NO.	PART NUMBER	DESCRIPTION	QUANTITY
34		FRAME BASE ASSEMBLY (OPTIONAL PARTS)	
73	0797-0078-2	CLAMP, Motor Bracket	1
74	0797-0376	EXT, Holddown (Not Shown)	1
75	0797-3100	FRAME, Main	1
76	4090-0233-0023	CAP, B.B.	2
77	4090-0244-0005	CAP	1
78	0797-3257	FOOT, Rubber	4
79	0797-0285-0002	GUIDE, Extension, L.H.	1
80	0797-0284	GUIDE, Adjustable Side	2
81	0797-3103	TABLE	1
82	0797-3104	STOP, Bread	1
83	5911-7000	KNOB	3
84	0797-3013-0002	BRACKET, Table Hinge, L.H.	
85	0797-0358-201	HOLDDOWN	1
86	0797-3012	BRACKET, Holddown	1
87	5911-7001	KNOB, Ball	1
88	0797-3110-4XX **	GUIDE, Knife	1
89	0797-3401 ***	WHEEL, 3" Caster Swivel	2
90	5902-2363 ***	WHEEL, 3" Caster	2
91	0797-2048-001 ***	SCOOP, Bagging	1
92	0797-3108	SLIDE, Drawer	1
93	6904-6000	GASKET, Rocker Shaft	3
94	6904-6001	GASKET, Driven Pulley	1
95	4090-0233-0025	CAP, B.B.	1
96	0797-3105-4XX **	LIP, Table	1
97	0797-0285-0001	GUIDE, Extension, R.H.	1
98	0797-3013-0001	BRACKET, Table Hinge, R.H.	1

** Specify Slice Width

*** Optional Item

FIGURE & ITEM NO.	PART NUMBER	DESCRIPTION	QUANTITY
34 99	5106-8920	. CAP, Neoprene	2
100	5843-2067	. SCREW, Socket Head Set	1
101	0797-3048 ***	. TABLE, Curved Outfeed	1
102	0797-3030-1001 ***	. GUIDE, Side, R.H.	1
103	0797-3030-1002 ***	. GUIDE, Side, L.H.	1
104	0797-3040-1002 ***	. BRACKET, Hinge, L.H.	1
105	0797-3040-1001 ***	. BRACKET, Hinge, R.H.	1
106	5851-8120 ***	. WASHER, Nylon	12
107	7013-2100***	. SPRING	4
108	5831-8102 ***	. NUT, Acorn, 1/4-20	4
109	4130-0708-0002 ***	. COLLAR, Filling	4
110	0797-3069	. BASE, 21" Caster	1
111	0797-3101	. BRACKET, Motor	1
112	0797-3108-001	. SLIDE, Drawer	1
113	0797-3109	. DRAWER, Crumb	1

*** Optional Item

Revised 7-25-95

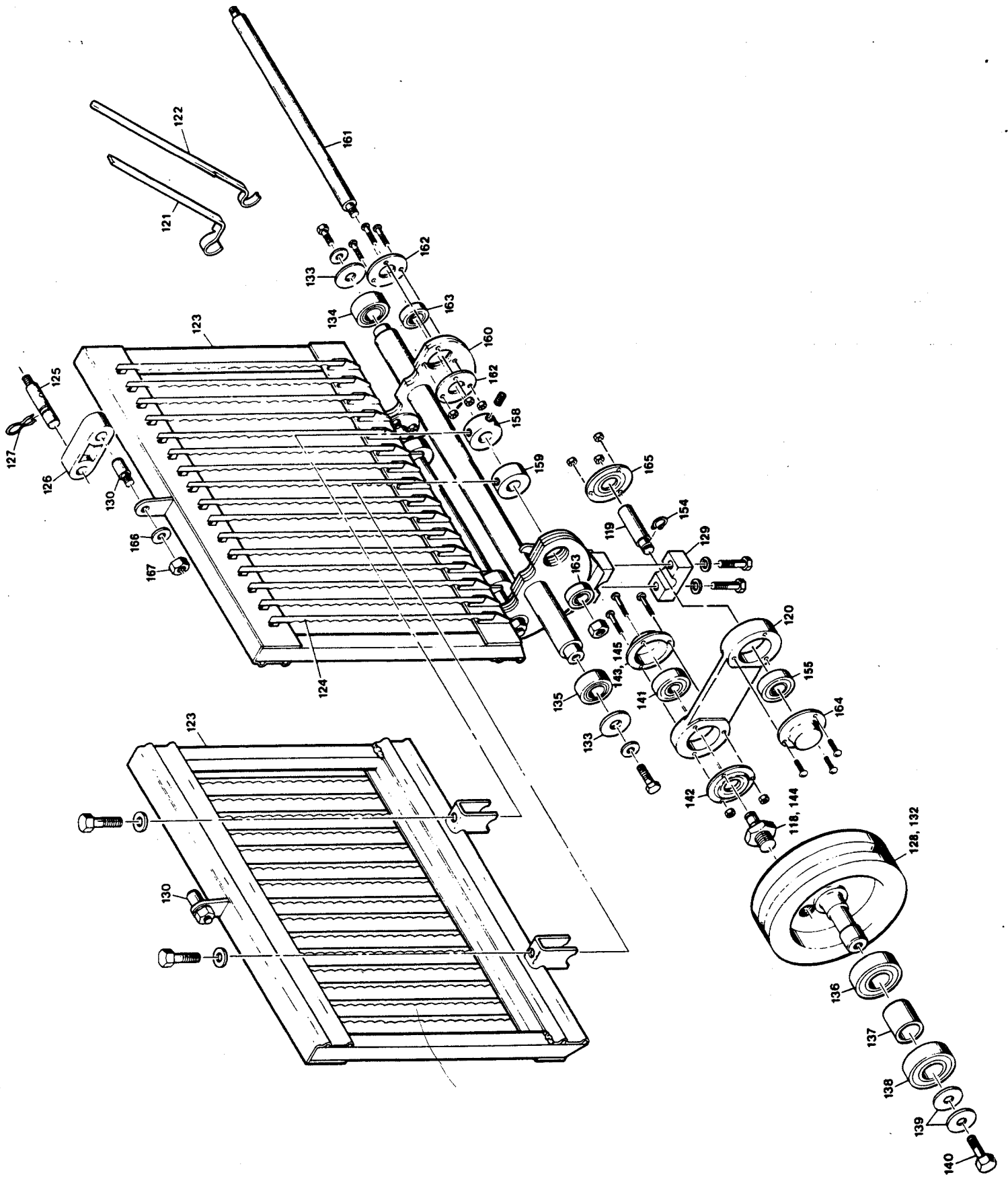

Figure 35. Rocker Blade Frame Assembly

FIGURE & ITEM NO.	PART NUMBER	DESCRIPTION	QUANTITY
35		ROCKER BLADE FRAME ASSEMBLY	
118	0797-3134	. STUD, Crank	1
119	0797-0057-2	. STUD, Swing	1
120	0797-0271-001	. ROD, Connecting	1
121	0797-0183-004 ****	. TOOL, Knife Removing	1
122	0797-0183	. TOOL, Knife Removing	1
123	0797-3102-9XXX **	. FRAME, Steel Blade	2
124	0797-0029-1	. BLADE	AR
125	0777-0034	. PIN, Eccentric	4
126	0711-0002	. LINK, Top	4
127	5835-7705	. CLIP, Hairpin	4
128	0797-0249-003 ****	. DRIVEN PULLEY	1
129	0797-0047-003	. CAP, Stud	1
130	0797-0059-2	. PIN, Blade Frame	4
132	0797-0249	. DRIVEN PULLEY	1
133	5851-8100	. WASHER, Special	2
134	5220-4040	. BEARING, Rocker Shaft	2
135			
136	5220-5040	. BEARING, Driven Pulley (205SZ)	1
137	4130-0132-0501	. COLLAR (117B)	1
138	5220-5001	. BEARING, Driven Pulley (205SG)	1
139	4655-0313-1401	. WASHER, Special #75	2
140	4560-1012-1201	. SCREW, Hex Head Special #83	1
141	5250-7030	. BEARING, Connection Rod (Spherical)	1
142	4090-0563-0001	. CAP	2
143	4090-0263-0002 *	. CAP (43)	-
144	4460-0124-2201	. NUT, BRG (Not Shown)	1
145	5115-1425	. PLUG, BRG CAP (Not Shown)	-

AR As Required

** Specify Slice Width

**** Power Feed Only

*Changed to be same as
detail 142 9/14/89. Also
deleted detail 145

FIGURE & ITEM NO.	PART NUMBER	DESCRIPTION	QUANTITY
35 154	5840-2825	. RING, Retaining	1
155	5220-2600	. BEARING, Connecting Rod	1
158	0797-0231	. COLLAR, Locating	2
159	0797-0231-001	. COLLAR, Holddown	2
160	0797-0247-2	. FRAME, Rocker	1
161	0797-0260-1	. SHAFT, Swing	2
162	4090-0232-0005	. CAP, Ball Bearing	4
163	5220-0220	. BEARING	4
164	4090-0232-0013	. CAP (36A)	1
165	4090-0232-0012	. CAP (38A)	1
166	5851-9010	. WASHER, 3/8 Lock	2
167	5832-0127	. NUT, 3/8-24 NF	2

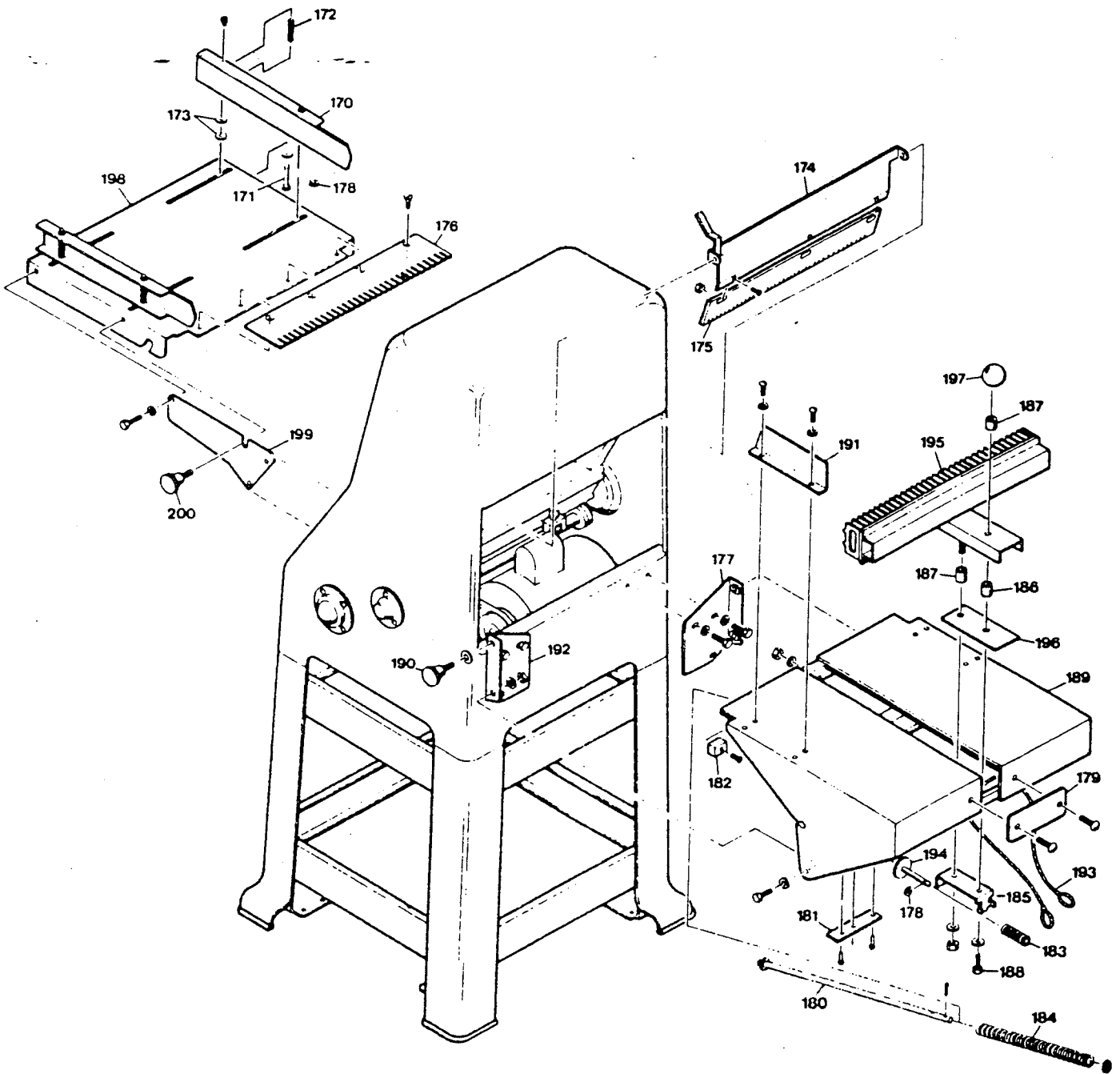

Figure 36. Spring Feed Slicer Exploded View

FIGURE & ITEM NO.	PART NUMBER	DESCRIPTION	QUANTITY
36		SPRING FEED SLICER ASSEMBLY	
170	0797-0723	. GUIDE, Side	2
171	0797-3011-002	. PIN	4
172	7012-3102	. SPRING (#97)	4
173	5851-8120	. WASHER, Nylon	12
174	0797-0330-3	. HOLDDOWN	1
175	0797-3116-4XX **	. GUIDE, Knife	1
176	0797-3105-4XX **	. LIP, Table	1
177	0797-3002-0001	. BRACKET, Spring Feed Table, R.H.	1
178	0793-0084	. WASHER, Horseshoe	9
179	0797-0274	. PLATE, Back	1
180	0797-0314	. ROD, Spring	2
181	0797-0341	. COVER, Switch	1
182	0797-3378	. BUMPER, Rubber	1
183	7012-3001	. SPRING (#100)	1
184	7013-8101	. SPRING (#123)	2
185	0797-0349	. BRACKET, Stop	1
186	4130-0113-0001	. COLLAR	1
187	4130-0113-0005	. COLLAR	2
188	4560-1012-1202	. SCREW, Hex Cap #63	1
189	0797-3113	. TABLE, Infeed	1
190	4560-2010-1103	. KNOB, Shoulder	2
191	0797-0326	. GUIDE, Infeed End	1
192	0797-3002-0002	. BRACKET, Spring Feed Table, L.H.	1
193	0797-0351	. CABLE	2
194	0797-0339	. PLUNGER, Switch	1
195	0797-0360-4XX **	. PUSHER	1
196	0797-0348	. PUSHER, Side	1
197	5911-7002	. KNOB, Ball	1
198	0797-3114	. TABLE, Outfeed	1
199	0797-3003-1	. BRACKET, Outfeed Table	2
200	4560-2010-1104	. KNOB	2

**Specify Slice Width

THIS PAGE WAS INTENTIONALLY
LEFT BLANK.



WARRANTY

PARTS

Oliver Packaging & Equipment Company (Oliver) warrants that if any part of the equipment (other than a part not manufactured by Oliver) proves to be defective (as defined below) within one year after shipment, and if Buyer returns the defective part to Oliver within one year, Freight Prepaid to Oliver's plant in Grand Rapids, MI, then Oliver, shall, at Oliver's option, either repair or replace the defective part, at Oliver's expense.

LABOR

Oliver further warrants that equipment properly installed in accordance with our special instructions, which proves to be defective in material or workmanship under normal use within one (1) year from installation or one (1) year and three (3) months from actual shipment date, whichever date comes first, will be repaired by Oliver or an Oliver Authorized Service Dealer, in accordance with Oliver's published Service Schedule.

For purposes of this warranty, a defective part or defective equipment is a part or equipment which is found by Oliver to have been defective in materials workmanship, if the defect materially impairs the value of the equipment to Buyer. Oliver has no obligation as to parts or components not manufactured by Oliver, but Oliver assigns to Buyer any warranties made to Oliver by the manufacturer thereof.

This warranty **does not** apply to:

1. Damage caused by shipping or accident.
2. Damage resulting from improper installation or alteration.
3. Equipment misused, abused, altered, not maintained on a regular basis, operated carelessly, or used in abnormal conditions.
4. Equipment used in conjunction with products of other manufacturers unless such use is approved by Oliver Products in writing.
5. Periodic maintenance of equipment, including but not limited to lubrication, replacement of wear items, and other adjustments required due to installation, set up, or normal wear.
6. Losses or damage resulting from malfunction.

The foregoing warranty is in lieu of all other warranties expressed or implied AND OLIVER MAKES NO WARRANTY OF MERCHANTABILITY OR FITNESS FOR PURPOSE REGARDING THE EQUIPMENT COVERED BY THIS WARRANTY. Oliver neither assumes nor authorizes any person to assume for it any other obligations or liability in connection with said equipment. OLIVER SHALL NOT BE LIABLE FOR LOSS OF TIME, INCONVENIENCE, COMMERCIAL LOSS, INCIDENTAL OR CONSEQUENTIAL DAMAGES.



Oliver Packaging & Equipment Company
511 Sixth Street NW • Grand Rapids, MI 49504

(800) 253-3893
www.oliverquality.com

WARRANTY PROCEDURE

1. If a problem should occur, either the dealer or the end user must contact the Parts and Service Department and explain the problem.
2. The Parts and Service Manager will determine if the warranty will apply to this particular problem.
3. If the Parts and Service Manager approves, a Work Authorization Number will be generated, and the appropriate service agency will perform the service.
4. The service dealer will then complete an invoice and send it to the Parts and Service Department at Oliver Products Company.
5. The Parts and Service Manager of Oliver Packaging and Equipment Company will review the invoice and returned parts, if applicable, and approve for payment.



Oliver Packaging & Equipment Company
511 Sixth Street NW • Grand Rapids, MI 49504

(800) 253-3893
www.oliverquality.com

RETURNED PARTS POLICY

This policy applies to all parts returned to the factory whether for warranted credit, replacement, repair or re-stocking.

Oliver Packaging and Equipment Company requires that the customer obtain a Return Material Authorization (RMA) number before returning any part. This number should appear on the shipping label and inside the shipping carton as well. All parts are to be returned prepaid. Following this procedure will insure prompt handling of all returned parts.

To obtain an RMA number contact the Repair Parts Department toll free at (800) 253-3893.

Parts returned for re-stocking are subject to a **RE-STOCKING CHARGE**.

Thank you for your cooperation,

Repair Parts Manager
Oliver Packaging and Equipment Company