

## SFC SERIES MODELS

## OWNER'S MANUAL



**Be sure ALL operators read, understand and have access to this manual at all times.**

PHONE: 603-225-6684  
MAILING ADDRESS: P.O. Box 501, Concord, NH 03302-0501  
SHIPPING ADDRESS: 10 Ferry St., Concord, NH 03301  
FAX: 603-225-8472  
GENERAL INFORMATION: [profits@perfectfry.com](mailto:profits@perfectfry.com)  
CUSTOMER SUPPORT: [service@perfectfry.com](mailto:service@perfectfry.com)  
WEB: [www.perfectfry.com](http://www.perfectfry.com)

©2012 PERFECT FRY COMPANY



# TABLE OF CONTENTS

<b>THANK YOU FOR PURCHASING A PERFECT FRYER!</b> .....	<b>1</b>
WARRANTY REGISTRATION .....	1
FRYER ACTIVATION .....	1
<b>OWNERS RESPONSIBILITIES</b> .....	<b>2</b>
<b>REGULATIONS &amp; RECYCLING</b> .....	<b>3</b>
<b>SAFETY FIRST</b> .....	<b>4</b>
<b>INSTALLATION</b> .....	<b>5</b>
ELECTRICAL POWER SUPPLY .....	5
ELECTRICAL SPECIFICATIONS .....	5
PREPARE COUNTER-TOP AREA.....	6
UNPACK .....	6
<b>ASSEMBLY</b> .....	<b>9</b>
<b>COOKING</b> .....	<b>12</b>
<b>CLEANING</b> .....	<b>13</b>
DAILY MAINTENANCE .....	13
WEEKLY MAINTENANCE.....	13
PERIODIC MAINTENANCE.....	15
<b>TIPS ON DEEP FRYING</b> .....	<b>16</b>
<b>OIL FACTS</b> .....	<b>17</b>
<b>OPERATING INSTRUCTIONS</b> .....	<b>20</b>
STARTING UP .....	21
MANUAL MODE .....	21
PRESET TIMES .....	21
PRESET MODE .....	22
PRESET LOCKED MODE.....	22
COOKING TIME CORRECTION.....	23
OPEN DOOR – PAUSED COOKING .....	23
STANDBY MODE .....	24
SHUTTING DOWN .....	24
<b>USER DEFINED OPTIONS</b> .....	<b>25</b>
BACKGROUND MENU - ACCESSING .....	26
CTS™ (COOK TIME SENSITIVITY).....	26
BACKGROUND MENU - MAP .....	26
OPTION CHANGES .....	30
CUSTOMIZING PRESETS .....	31
CUSTOMIZING PRESETS ON THE FRONT LABEL .....	32
<b>HELP</b> .....	<b>33</b>
SYSTEM ERROR CONDITIONS .....	33
TROUBLE-SHOOTING TABLE.....	35
<b>PFS AUTOMATIC EXTINGUISHER</b> .....	<b>36</b>
<b>BLOW-APART DIAGRAM &amp; PARTS LIST</b> .....	<b>38</b>
<b>THE PERFECT FRY 1 2 3 WARRANTY</b> .....	<b>39</b>

# Thank You for Purchasing a Perfect Fryer!

## Warranty Registration

To ensure that you receive the highest quality service & support;

1. Simply fill out the online warranty registration form anytime at [www.perfectfry.com](http://www.perfectfry.com) and automatically receive your warranty activation code.

**OR**

2. Fill out the enclosed warranty registration form and mail or fax it to Perfect Fry Company then phone 603-225-6684 (Monday-Friday 8:00-5:00 EST) to receive your warranty activation code.

## Fryer Activation

### SEE THIS LCD

THANK YOU FOR  
PURCHASING A PERFECT  
FRYER SN# XXXXX

CALL OR GO ONLINE  
ENTER WARRANTY CODE  
AND PRESS START:

▶\*\*\*\*\*

### Do This

- 1) Enter your warranty activation code
- 2) Press **Start**
- 3) Your Perfect Fryer is now permanently activated

### GET THIS LCD

HEATING

 **70°F**

For temporary access, enter 123456 then press **Start**.  
Temporary access is valid for 90 days.

Now that you have registered and activated your fryer;

- Take advantage of our food program partners whose rebates help offset the cost of your newly purchased Perfect Fryer. Food program rebates will be sent to you, however if you wish to view our current partners immediately, please visit [www.perfectfry.com](http://www.perfectfry.com).
- Take comfort in knowing that your Perfect Fryer is backed by an industry leading 1..2..3 warranty (see page 39 for further details).
- Take comfort in knowing that the management and staff at Perfect Fry Company are dedicated to ensure that you, the owner and operator of a Perfect Fryer, receive a top quality product that is thoroughly inspected and tested prior to shipment.
- Take comfort in knowing that our local distribution network is committed to supplying your service and warranty needs. Each distributor has dedicated service staff that is able to answer any questions you may have regarding the operation of your Perfect Fryer. We also have an online knowledgebase available 24/7/365 at [perfectfry.com](http://perfectfry.com) with many great tips and solutions.

# OWNERS RESPONSIBILITIES



## It is the owner's responsibility to:

- Insure the PERFECT FRYER is properly maintained.
- Allow only properly trained personnel to operate, clean and maintain a PERFECT FRYER.
- Contact local authorities having jurisdiction to insure that the installation conforms to all local fire, building and health regulations.
- Schedule and maintain documentation that the appropriate inspection and maintenance of the PFS Automatic Extinguisher has been completed.
- Insure that the model ready for installation matches the supply voltage.
- Insure that the main power supply is disconnected before the PERFECT FRYER is serviced.
- Insure that all safety devices are intact.
- Insure that a proper surface is provided for the PERFECT FRYER to sit on.
- Insure that proper clearances are kept.
- Operate and store the PERFECT FRYER above 32°F (0°C).
- Return the PERFECT FRYER for recycling when it reaches end of life.

# REGULATIONS & RECYCLING

Installation of your PERFECT FRYER must conform to all local fire and health regulations and building codes. The installation use and maintenance is to be in accordance with the Standard for Ventilation Control and Fire Protection of Commercial Cooking Operations, NFPA 96 - 2008.

The table below describes the standards that your PERFECT FRYER has been tested to and the corresponding listing marks.

STANDARD	DESCRIPTION	LISTING MARK
<p>UL 197 UL 197 SB (UL 710B)</p> <p>CSA 22.2 No. 109-M1981</p>	<p>Commercial electric cooking appliances. Commercial electric cooking appliances with recirculation systems.</p> <p>UL 197 &amp; UL 197 SB supplement also reference the following standards which your PERFECT FRYER meets applicable parts thereof:</p> <ul style="list-style-type: none"> <li>• UL 1046: Grease Filters for Exhaust Ducts.</li> <li>• UL 300: Fire Testing of Fire Extinguishing Systems for Protection of Restaurant Cooking Areas.</li> <li>• NFPA 17A: Wet Chemical Extinguishing Systems.</li> <li>• NFPA 96: Standard for Ventilation Control and Fire Protection of Commercial Cooking Operations.</li> <li>• EPA 202: Determination of Condensable Particulate Emissions for Stationary Sources.</li> </ul> <p>Commercial Cooking Appliances forming part of Canadian Electrical Code, Part 2 Safety Standards for Electrical Equipment.</p>	
<p>NSF 4</p>	<p>Commercial Cooking, Rethermalization, and Powered Hot Food Holding and Transport Equipment.</p>	

# SAFETY FIRST



## LIFTING & MOVING:

- Your PERFECT FRYER's gross shipping weight is 92 lb. (42 kg). Net weight = 80 lb. (36 kg).

## DEEP FRYING:

- Cooking oil is very hot (350°F or 177°C). Hot oil can cause severe burns. **DO NOT TOUCH THE COOKING OIL UNLESS YOU ARE SURE IT HAS COOLED.**

## HEATER MODULE:

- DO NOT DROP
- DO NOT IMMERSE IN WATER

## CLEANING:

- Before cleaning fryer or removing oil, let fryer cool to 122°F (50°C). **DO NOT TOUCH HEATER MODULE, VAT OR OIL UNLESS YOU ARE SURE IT HAS COOLED.**

## COOKING OIL MAINTENANCE:

- For sanitation and safety, we recommend that the cooking oil is replaced once a week, more often for higher volume usage. Use a commercial grade deep-fryer formulated cooking oil. OLD OIL HAS A REDUCED FLASHPOINT. OLD OIL AND OVER-WET FOOD ARE PRONE TO SURGE BOILING.

## SERVICING:

- DISCONNECT THE POWER SOURCE BEFORE SERVICING THE FRYER. There is no need to unplug your PERFECT FRYER for normal cleaning or maintenance.

## STORAGE:

- Do not store your PERFECT FRYER below 32°F (0°C)

# INSTALLATION

## Electrical Power Supply

- Your PERFECT FRYER must be connected to a dedicated electrical circuit that meets your fryer's requirements (see table below).

**⚠ CAUTION** Improper Installation may damage the fryer and void your warranty

- If your PERFECT FRYER's plug does not fit your wall outlet receptacle, have an electrician install the appropriate NEMA receptacle within 4 feet of the fryer.
- See the manufacturer's label on your PERFECT FRYER for the electrical Model No. SFCXXX, then check off your Model Number.

## Electrical Specifications

PERFECT FRY MODEL	VOLTS	AMPS	CIRCUIT AMPS	WATTS	NEMA NUMBER	NEMA RECEPTACLE
↓ Put a check mark <input checked="" type="checkbox"/> in the box beside the Model Number of your PERFECT FRYER.						
<input type="checkbox"/> <b>SFC 187</b>	120	18.0	Minimum 20	2200		For use on an individual branch circuit rated 20A minimum. For supply connectors, use minimum no. 12 AWG wire (20A rated). This fryer must be properly connected to a grounded, dedicated 120 VAC single phase circuit according to local installation standards and codes.
<input type="checkbox"/> <b>SFC 375</b>	240	18.0	Minimum 20	4300		For use on an individual branch circuit rated 20A minimum. For supply connectors, use minimum no. 12 AWG wire (20A rated). This fryer must be properly connected to a grounded, dedicated 240 VAC single phase circuit according to local installation standards and codes.
<input type="checkbox"/> <b>SFC 570</b>	240	26.0	Minimum 30	6200		For use on an individual branch circuit rated 30A minimum. For supply connectors, use minimum no. 10 AWG wire (30A rated). This fryer must be properly connected to a grounded, dedicated 240 VAC single phase circuit according to local installation standards and codes.
<input type="checkbox"/> <b>SFC 570</b>	208	29.0	Minimum 30	6000		For use on an individual branch circuit rated 30A minimum. For supply connectors, use minimum no. 10 AWG wire (30A rated). This fryer must be properly connected to a grounded, dedicated 208 VAC single phase circuit according to local installation standards and codes.
All models are single phase; 50/60 hertz.						

## INSTALLATION (Continued)

### Prepare Counter-top Area

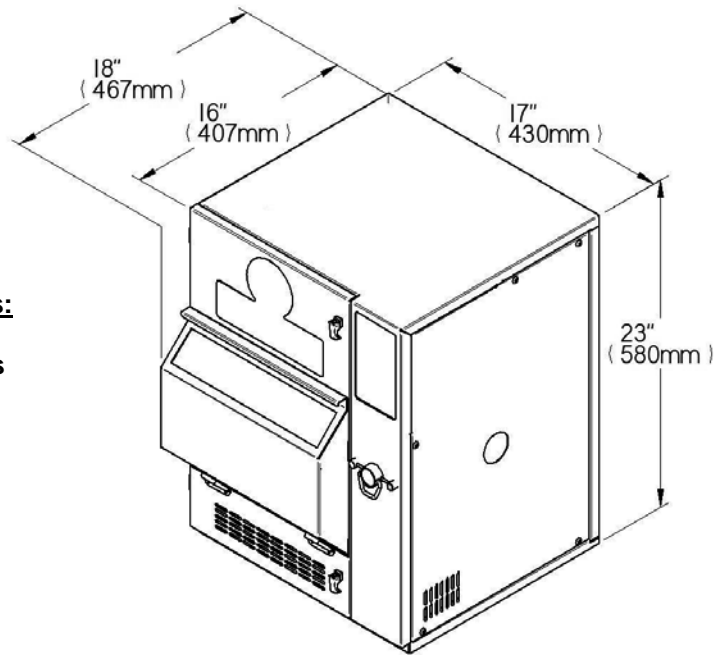

**Clearances:**

1" on sides  
2" on back  
0" on top

### Unpack

- 1) Cut straps on shipping box
- 2) Remove box top and body
- 3) Remove outer plastic wrapping and keep box along with foam corners and sides

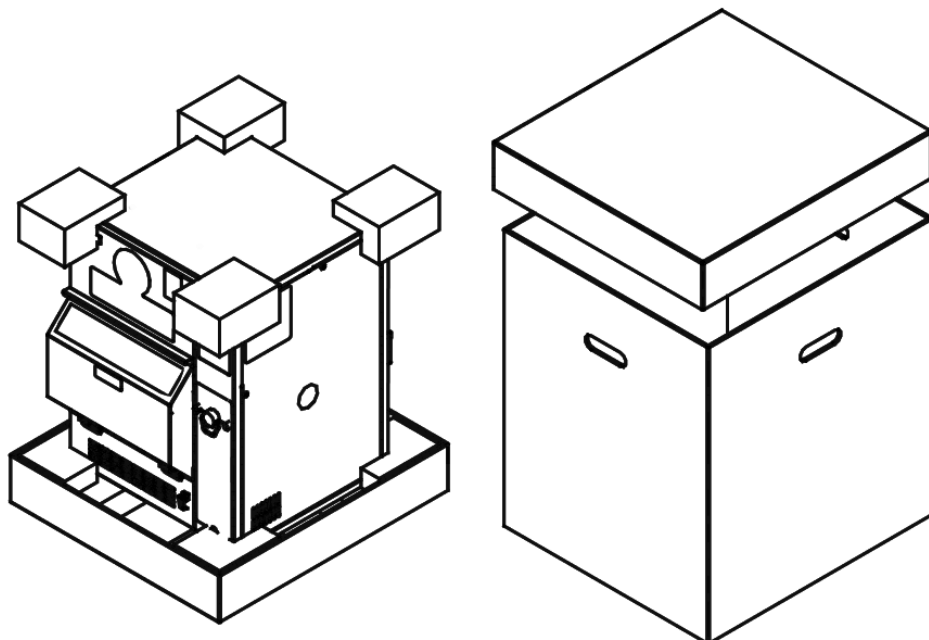



4) Lift your PERFECT FRYER onto counter-top

**⚠ CAUTION** Your PERFECT FRYER weighs 80 lb. (36 kg). Lift it carefully with your legs or with the help of another person and place it in its final location.

5) Remove all foam stuffing and parts

6) Put check mark  in box once the part is removed

- 1** Air Filter Cage
- 2** Air Filter Cartridge
- 3** Grease Filter
- 4** Grease Filter Tray
- 5** Drawer
- 6** Heater Module
- 7** Oil Vat
- 8** Oil Spill Tray
- 9** Front Panel
- 10** Door
- 11** Door Spring (2)
- 12** Handle
- 13** Basket Cover
- 14** Divider
- 15** Basket
- 16** Oil Drainage Kit (Optional)

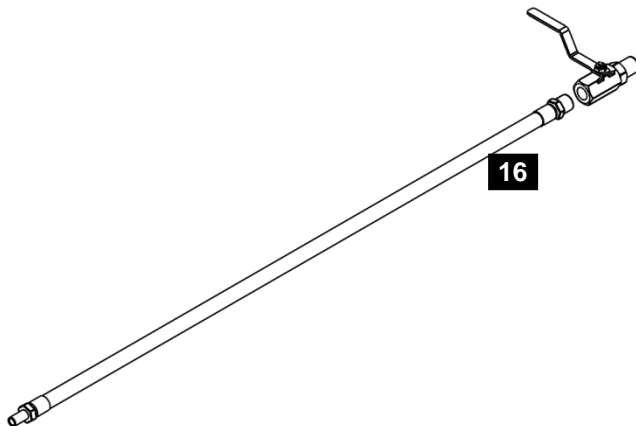
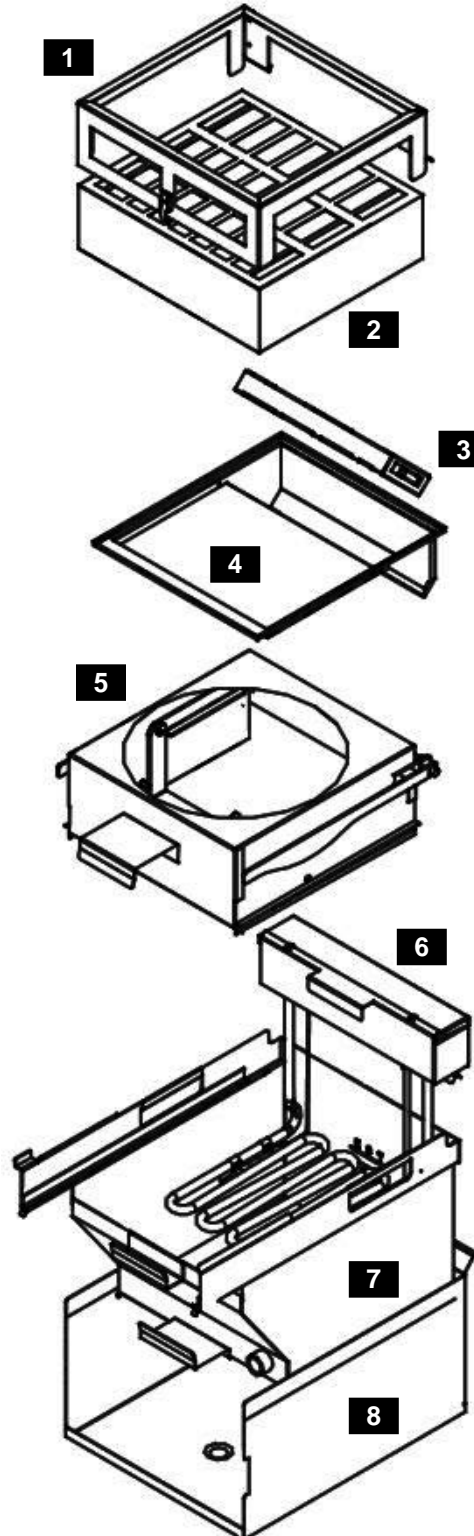

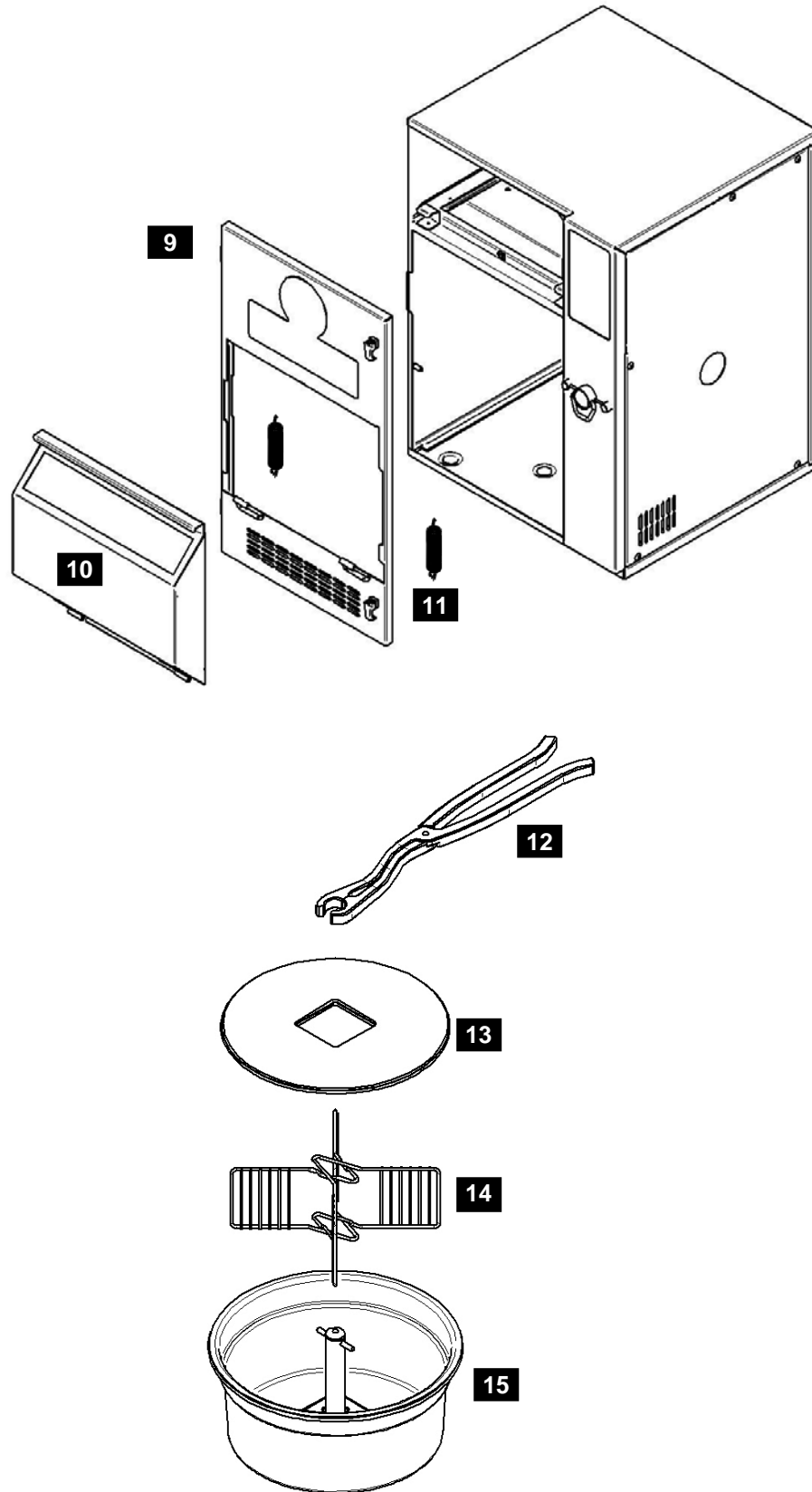

- 7) Ensure that blow-off caps on fire extinguisher nozzles are kept in place
- 8) Go to ASSEMBLY section (next page)

# ASSEMBLY

- 1) Clean parts and inside of cabinet (all except air filter cartridge)
  - a) Wash in warm soapy water
  - b) Rinse with hot water
  - c) Rinse with vinegar solution (1 part vinegar to 2 parts water)

**⚠ CAUTION** The heater box must **NOT** be immersed in water or other liquid.

- 2) Plug in fryer and press 

Note: LCD will display what is missing and will beep twice when part is installed

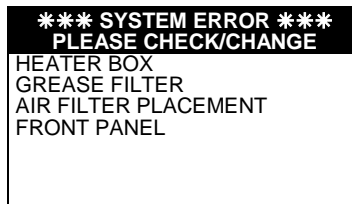

- 3) Install grease filter into grease filter tray  
Note: magnet should be on right side

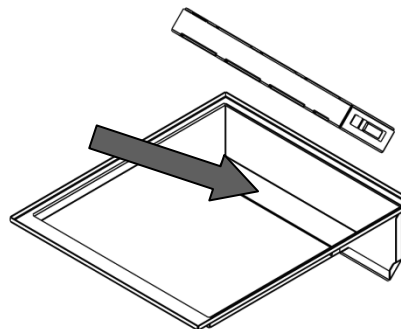

- 4) Install grease filter/grease filter tray into filter compartment by sliding along rails and towards back

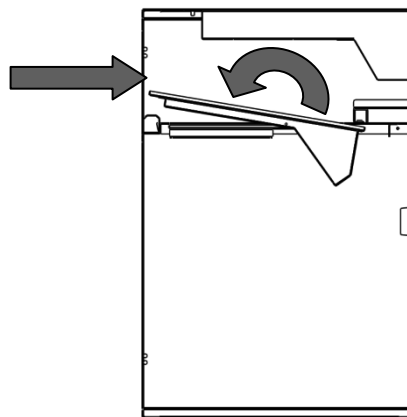

- 5) Fit air filter cage over air filter cartridge  
Note: Make sure arrows are pointing up

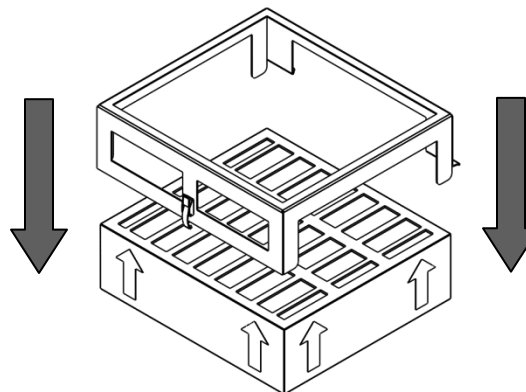

## ASSEMBLY (Continued)

- 6) Slide air filter cartridge firmly back into filter compartment and fasten down with latch.

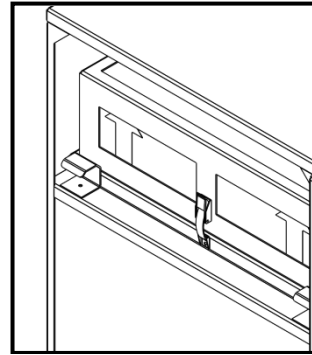

- 7) Install spill tray into bottom cooking compartment

Note: Indents on bottom of spill tray should fit into indents on bottom of cabinet

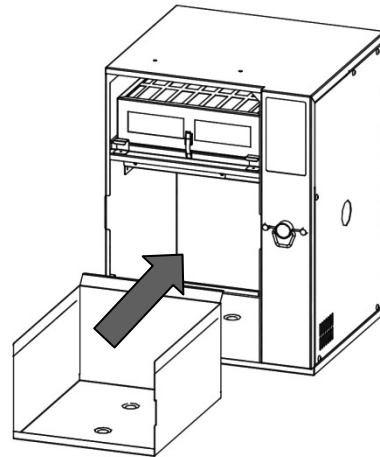

- 8) Set heater module onto vat

Note: “^” grooves on bottom of heater module should fit onto back of vat

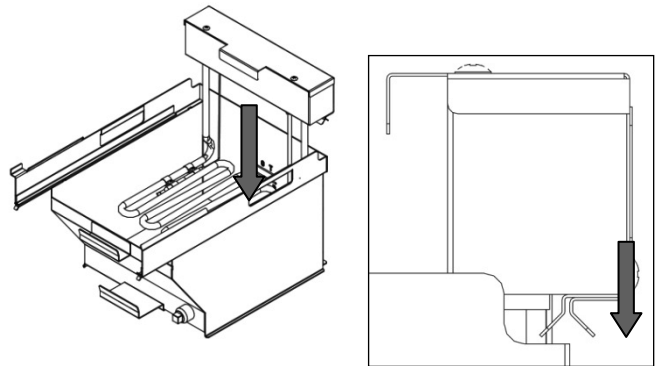

- 9) Pour frying oil into vat. Fill to **COLD** level mark. Use commercial grade deep fryer cooking oil. DO NOT OVERFILL.

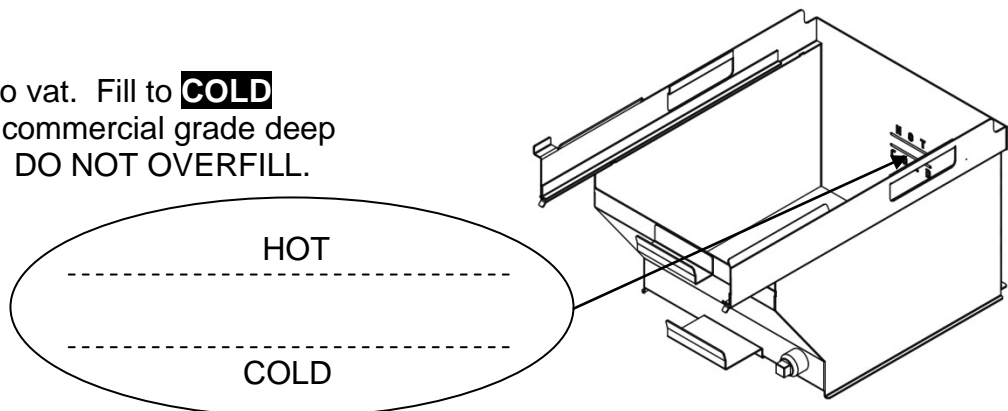

## ASSEMBLY (Continued)

- 10) Slide heater module/vat into cooking compartment and push in all the way. Ensure electrical connection is complete with a firm push on the heater module.

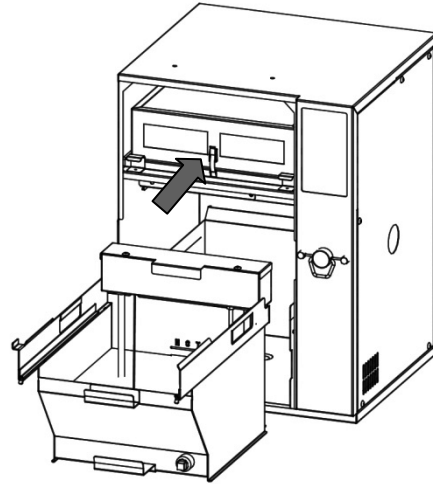

- 11) Install drawer

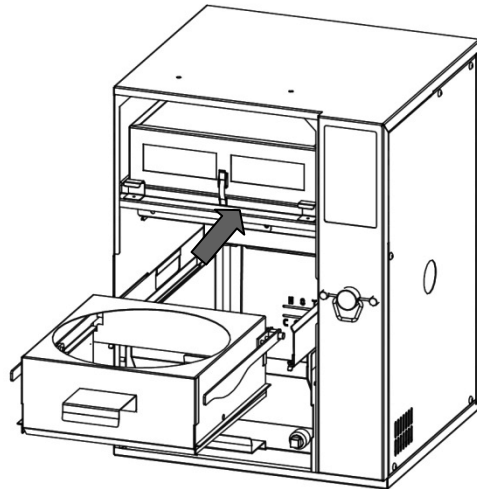

- 12) Install and close front panel. Turn latch  $\frac{1}{4}$  turn clockwise and press down

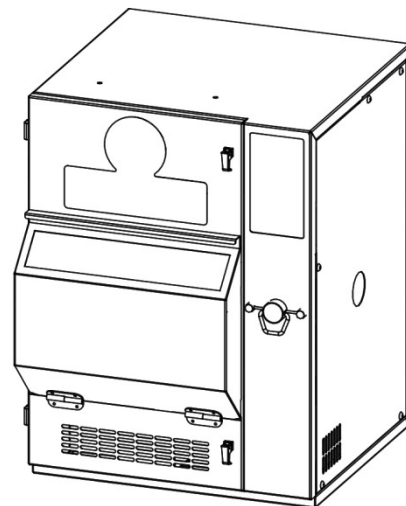

- 13) The fryer will now begin heating. In a few minutes, you will be ready to start cooking

# COOKING

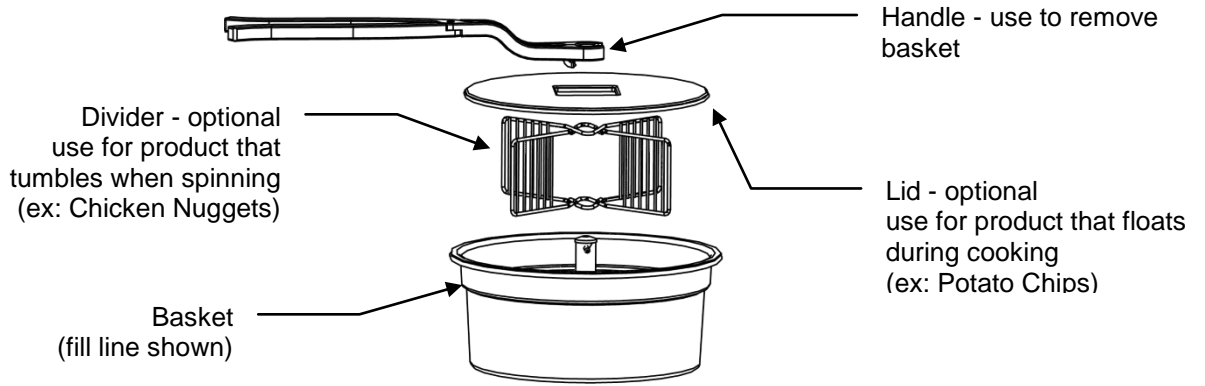

## 1. Load Basket Evenly and Insert

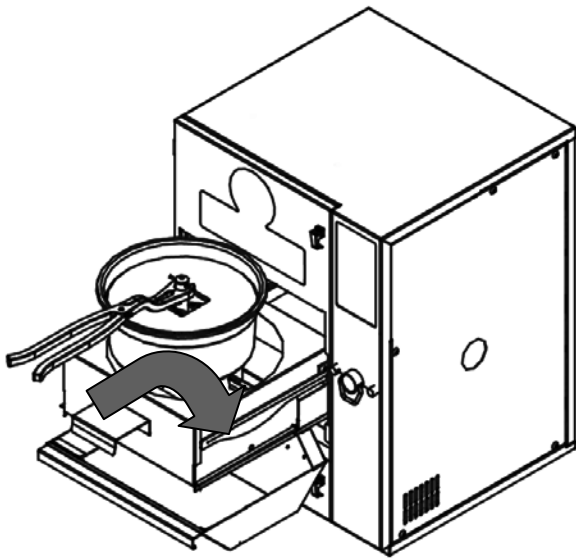

## 2. Press Start

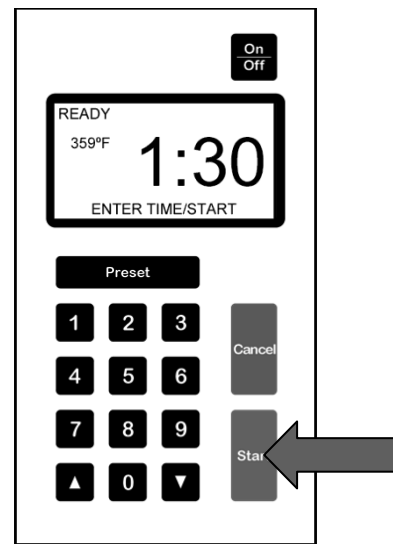

## 3. Frying then Spinning

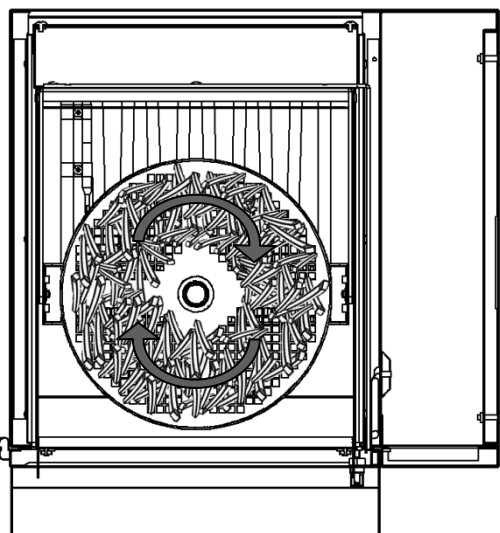

## 4. Remove & Serve

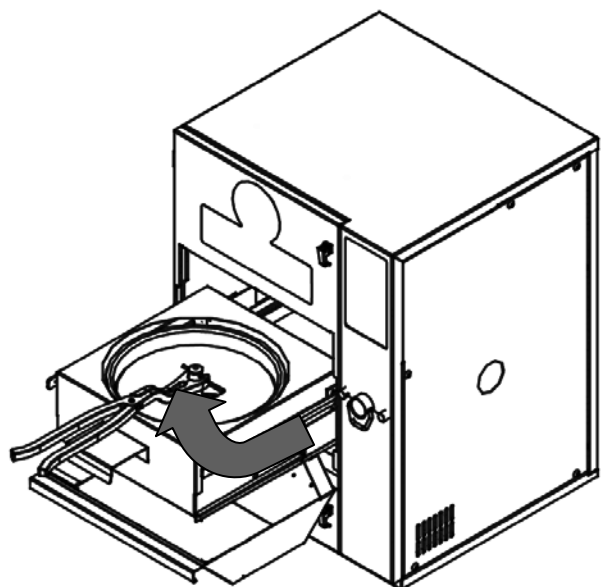

# CLEANING

## Daily Maintenance

**⚠ CAUTION** Do not unplug the fryer and always make sure the fryer is turned off

**⚠ CAUTION** Do not touch heater module, oil vat or oil unless you are sure it has cooled

- 1) Wipe basket(s) with paper towel to remove crumbs and food particles
- 2) Wipe crumbs, oil and any other food matter from inside of door into spill tray using a paper towel
- 3) Clean outside of fryer with a good stainless steel cleaner and wipe dry

**⚠ CAUTION** Do not clean the outside or any other stainless steel part using abrasive cleaners

- 4) Check oil level on the back of vat to make sure it is up to cold line (at room temperature). If not, add oil as necessary. Replace the cooking oil once a week or more often if necessary. Use a **COMMERCIAL GRADE DEEP FRY COOKING OIL.**

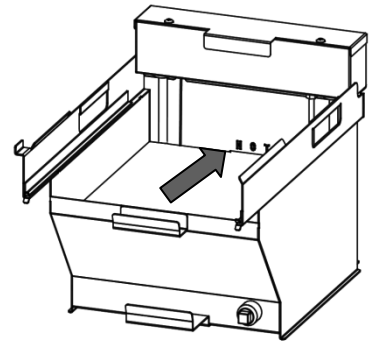

## Weekly Maintenance

**⚠ CAUTION** Do not unplug the fryer and always make sure the fryer is turned off

**⚠ CAUTION** Do not touch heater module, oil vat or oil unless you are sure it has cooled

- 1) Open front panel by lifting and turning latches. Lift it off its hinges. The front panel can be cleaned as is or apart if preferred.
- 2) Remove air filter cartridge and set aside (for replacement, see page 15).

**⚠ CAUTION** Do not wash air filter cartridge

- 3) Remove grease filter tray from cabinet. Remove grease filter from tray and drain any oil that has accumulated. Wash both parts in soap and hot water. Rinse well in hot water and dry.

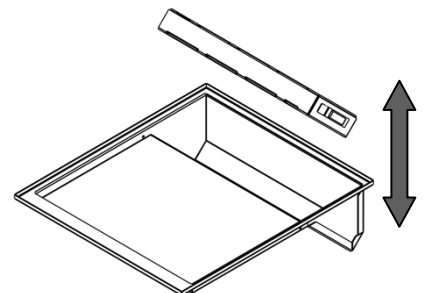
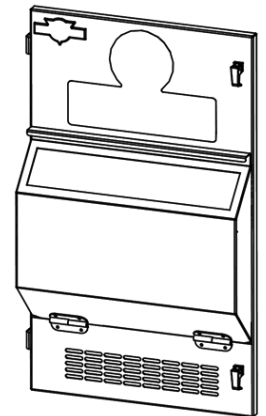

## CLEANING (Continued)

4) Pour cooking oil from vat into containers for disposal. Have empty containers handy for proper disposal of used cooking oil. A rendering company can help with proper disposal.

5) Remove drawer housing, oil vat and heater module (picture right). Use a spray on oven cleaner and enclose with plastic bag for at least one hour or leave overnight if possible. Wash in soap and hot water and rinse well in hot water. Rinse parts in a solution of: 1 part white vinegar [5% acetic acid] and 2 parts water. **The vinegar rinse is very important.** It neutralizes soap residue that causes oil breakdown foaming. Soap residue turns oil dark and reduces its performance significantly. Clear water rinse parts. **Clean the male and female terminals on connectors with rubbing alcohol and cotton swab.**

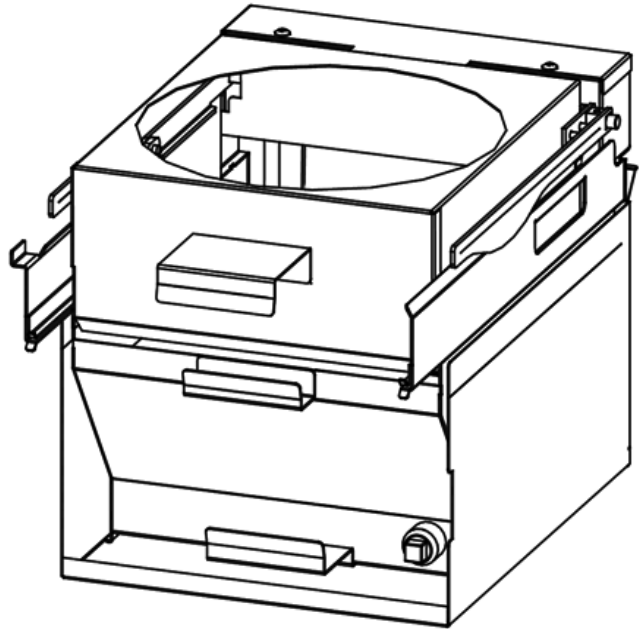

**⚠ CAUTION** **The heater box must NOT be immersed in water or other liquid.**

**⚠ CAUTION** **Do not spray male connector**

6) Remove spill tray and drain any oil that has accumulated. Wash in soap and hot water. Rinse well in hot water and dry.

7) With internal components removed, clean cooking and filter compartments with grease cutting soap or oven cleaner if necessary. Rinse with damp cloth and dry.

**⚠ CAUTION** **Do not spray female connector**

8) Move fryer, clean counter-top and external surfaces

9) Ensure that blow-off caps on fire extinguisher nozzles are kept in place

10) Re-install all parts (see ASSEMBLY page 9)

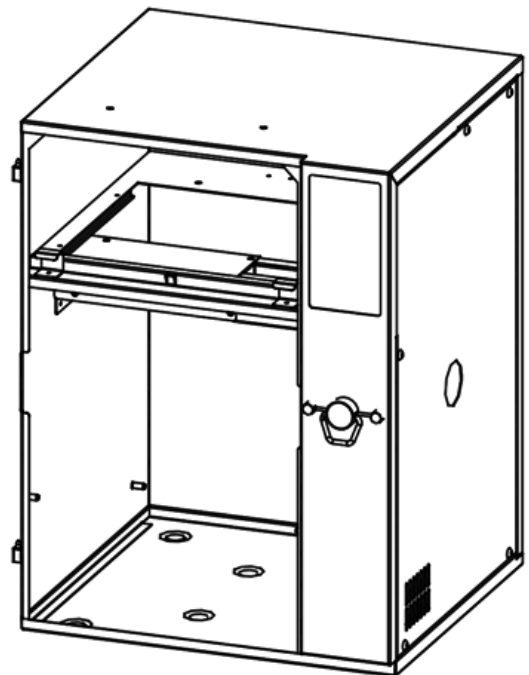



## CLEANING (Continued)

### Periodic Maintenance

#### Air Filter Cartridge Replacement

- Replace the air filter cartridge at least once every 3 months, more often for higher volume usage. Replacement is safer and easier when the fryer is cool rather than hot.
- Only PERFECT FRY filters may be used in your PERFECT FRYER.

Steps to replace air filter cartridge:

- 1) Open front panel by lifting and turning latches
- 2) Release latch on air filter cage, and remove air filter cage and air filter cartridge from filter compartment
- 3) Remove old used air filter cartridge from air filter cage
- 4) Wipe air filter cage clean
- 5) Fit air filter cage over new air filter cartridge and write date on cartridge  
(↑↑ Arrows up)
- 6) Install air filter cage and new air filter cartridge firmly back into filter compartment and latch in place
- 7) Close front panel and latch shut

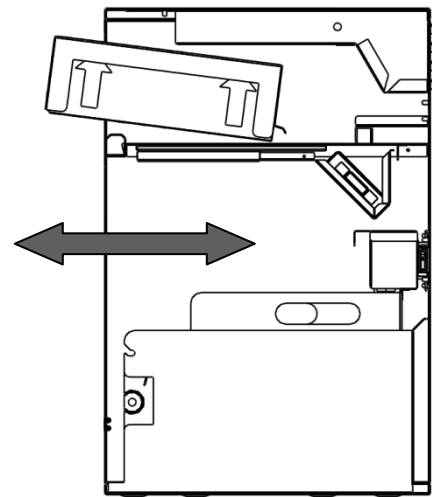
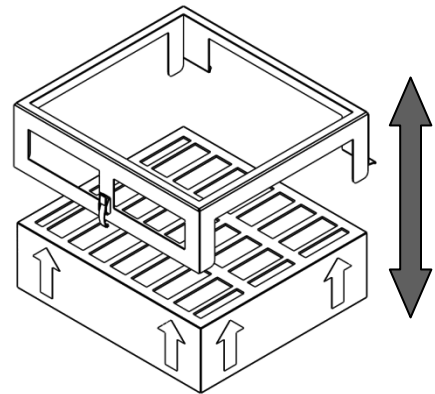

#### PFS Automatic Extinguisher

- The PFS automatic extinguisher must be inspected monthly by the owner/operator and semi-annually by authorized service personnel as per NFPA 17A. It is important that a maintenance program is set up with a local fire service company to ensure that local jurisdictional codes are being met. Please refer to PFS automatic extinguisher (page 36) for more information.

# TIPS ON DEEP FRYING

## Great Food in Less Time

- **Use premium quality commercial deep frying oil.** Canola and Soybean oils are recommended. Do not use household cooking oils from your local supermarket. Poor quality oils may shorten the life of the air filter cartridge.
- **Keep food frozen until ready to fry.** Frozen product will absorb less oil during the cooking process.
- **Remove ice from food.** Ice results in excess bubbling and spillage of oil out of the vat.
- **Minimize the moisture.** Excess moisture extends the cooking time. Water, ice, sugar and breading all contribute to shortening the life of the oil.
- **Try to reduce the amount of breading that falls off of the food.** Breading often has sugar and other ingredients that will reduce the oil's life and darken the appearance of food. Consider filtering the oil to remove the breading particles.
- **Do not overfill the basket.** Excess food may not be cooked properly.

**MINIMIZE THE MOISTURE  
REDUCE THE COOKING TIME  
MAXIMIZE THE PROFIT**

## Common Questions

- **How Much Oil to Use?**  
The PERFECT FRY has a capacity of 2 gallons of oil (8L). Fill the oil vat to the cold line only.
- **How Much to Fry?**  
Fill the basket to the fill line only. The basket has an approximate capacity of 2 lbs (1 kg) of product per cycle.
- **What is the Ideal Temperature Range for Cooking?**  
The ideal temperature range for cooking product is between 350°F and 360°F (177°C and 180°C). The factory default setting for cooking temperature is 350°F (177°C).
- **Should Frozen Food Be Defrosted?**  
DO NOT THAW FROZEN FOOD! Frozen foods only should be put directly into the fryer in order to minimize moisture.
- **Can I Refreeze Frozen Foods?**  
NO, do not refreeze frozen foods. Foods that are refrozen can absorb more oil, which will result in a dry, brittle and tasteless product.

# OIL FACTS

Frying oil is especially formulated to withstand high temperatures. For this reason, you must ensure you are using the right product. Liquid vegetable shortening is produced by several companies; the oil has an additive and/or has been formulated to increase the performance during high temperature usage.

## **DO NOT USE OIL THAT IS RECOMMENDED BOTH FOR SALAD AND FRYING!**

Fill the oil vat to the cold line only. The oil expands as it heats and if overfilled, the bottom of the basket will remain in the oil when in the up/serve position.

### **How Much to Fry?**

- Fill the basket no higher than the fill line. Do not overload the basket.
- Keep baskets clean and free of breading/batter build up.
- Remove ice crystals or excess water before frying.
- Do not salt or season before frying.
- Remove surplus and/or batter before frying.
- Do not allow frozen food to thaw before frying.
- Drain fried foods before serving.

### **How Hot is TOO Hot?**

Ideal frying temperature range is between 350°F and 360°F (177°C and 180°C). Factory default setting is 350°F (177°C). When frying at too low a temperature, food absorbs more oil which increases oil consumption.

### **Excessive Oil Usage?**

The fried product is absorbing oil. Possible reasons for this include:

- Excess breading or batter, shake off excess before frying.
- Allow basket to drain longer, adjust the drain time.
- Food is being allowed to thaw before frying.

### **Cleaning Your Fryer?**

- Refer to the Cleaning section of this owner's manual. Remember to clean the basket and drip tray.

### **Filtering Your Oil?**

The most important procedure you can do is to maintain the oil, extending its life:

- Filter at least once a day, preferably first thing in the morning when the oil is at room temperature.
- Filtering removes all the contaminants from the previous days cooking.
- Clean the oil vat.

### **Points to Remember:**

- Clean the cooking chamber at least once a week and rinse thoroughly.
- Filter oil daily.
- Do not overheat oil.
- Use the standby mode when possible.
- Do not salt product prior to frying.
- Remove ice crystals and moisture before frying.
- Maintain oil level in vat, check to ensure it is at the hot line often.
- The oil is dead when foaming appears continuously on the oil surface

**Your oil, product taste, and customers depend on you.**

## OIL FACTS (Continued)

If the oil temperature is set too high, the food will cook on the exterior and the interior will be undercooked. When the interior is cooked completely, the exterior will be overdone or burnt. The higher temperature will also cause the oil to break down faster and smoke.

During slow periods, take advantage of the standby mode which allows the oil to cool down to 275°F (135°C), prolonging the oil life and reducing energy costs while allowing quick recovery time when required.

The oil temperature should not be adjusted when cooking different products. Adjust the cooking time instead.

### Frozen Foods

Put frozen foods directly into the fryer. **DO NOT THAW FROZEN FOODS!** Blot excess water from food before frying. Remove ice crystals that may be at the bottom of the product bag.

**OIL AND WATER DO NOT MIX!** Water reacts with oil and makes it break down rapidly resulting in darkening, smoking and foaming (a process called hydrolysis). Excess water in the oil can cause the following problems:

- Unnecessary temperature drop meaning longer cooking times.
- More energy usage to maintain cooking temperature.
- Excessive splattering inside the fryer resulting in a mess to clean up.
- Decreased life of the air filter and the oil.

### Refreezing Frozen Foods?

Frozen foods should be fried frozen. Foods that are refrozen can absorb more oil and make your fried foods taste greasy. Refrozen food forms excessive ice and these ice crystals can bond food pieces together causing clumping. Remember:

- Always FRY FOOD FROZEN.
- NEVER REFREEZE thawed food.
- REMOVE ice crystals from product before frying.
- DO NOT accept thawed or refrozen product from supplier.

### Excessive Foaming?

The main reason for foaming is improper rinsing of oil vat after cleaning:

- To remove soap residue, rinse 3 times with water after cleaning or neutralize with a water and vinegar solution (1 part white vinegar to 2 parts water).
- Take care of your oil; use standby mode during slow periods. High temperature and oxygen contribute to oil breakdown. Filter oil and clean vat at least once a day when using heavily breaded products.

### Excessive Smoking/Oil Darkening?

- Oil is too hot, check temperature.
- Inadequate filtering, breading or batter build-up in vat causes oil breakdown, giving food a bitter taste.
- Moisture content is too high. Use precooked frozen products only. Remember to remove ice crystals.

### Grease Soaked Food?

- Frozen food is being allowed to thaw before frying.
- Oil is in the advanced stages of breakdown, replace immediately.
- Oil temperature is too low, check temperature.
- Product has too much breading or batter, remove excess.

## OIL FACTS (Continued)

### Food Not Browning Properly?

- New oil may not brown the product; check color again after a few basket loads.
- Too much product is in the basket; fill no higher than the fill line.
- Product is not frying long enough, follow manufacturers suggested cooking times.
- Oil temperature is too low, check oil temperature.
- Product is frying in excess foam.
- Oil level is too low, check the oil level.

### Premature Oil Breakdown?

- Oil is at full temperature during slow periods, use standby mode.
- Oil is contaminated. Never use wire brushes, copper pads or steel wool for cleaning. Use a hard bristle brush and filter oil regularly. Rinse with water vinegar solution.
- Also, see section; **HOW HOT IS TOO HOT?**

Statements used in OIL FACTS section are taken from:

- NAFEM Food Service Industry
- Canola Research Foundation
- Sysco Oil Publication

# OPERATING INSTRUCTIONS

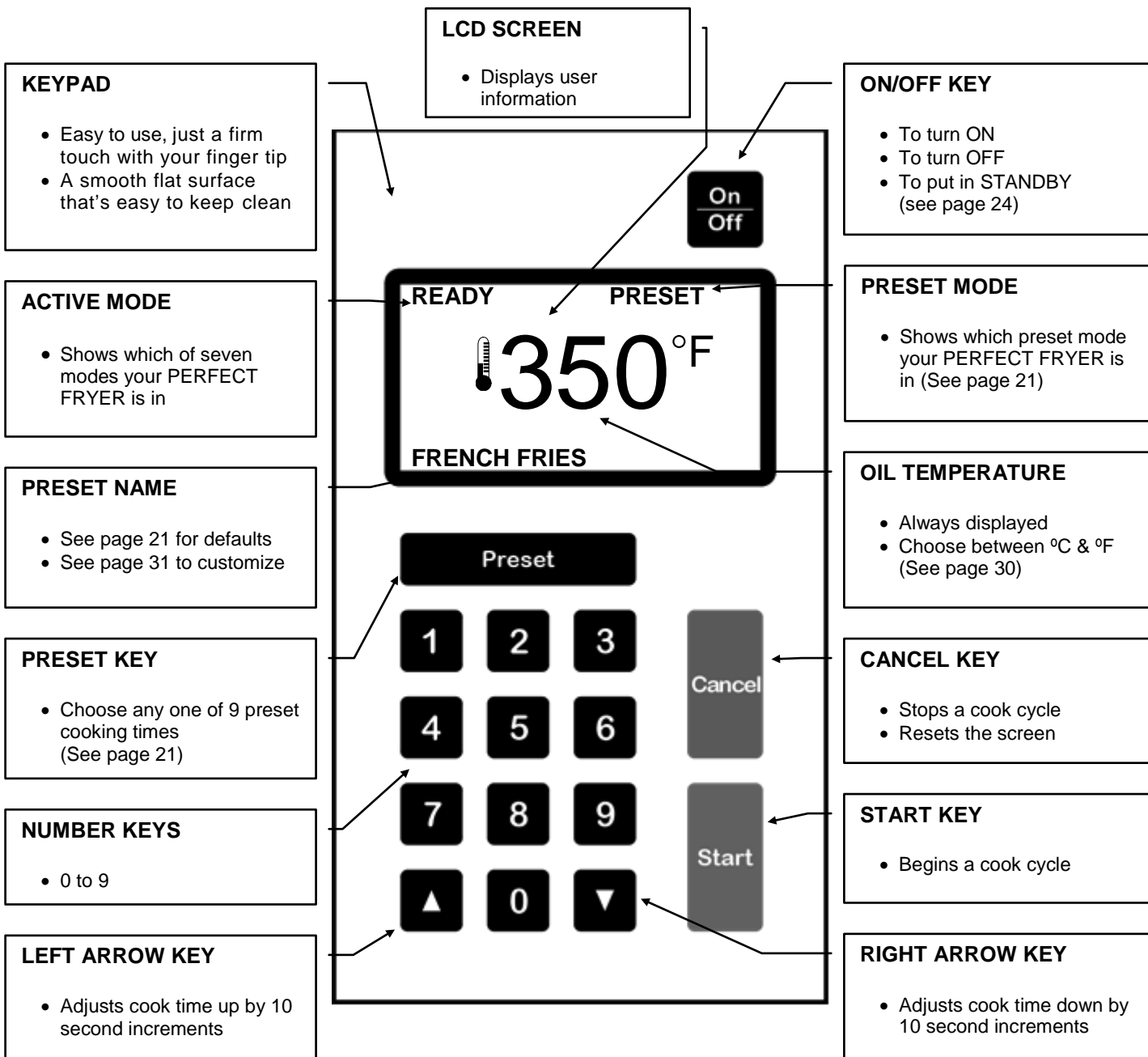

**Table 1 Preset Mode Functionality**

Feature	Manual Mode	Preset Mode	Preset Locked Mode
<i>Manually enter cook time</i>	<input checked="" type="checkbox"/>	<input type="checkbox"/>	<input type="checkbox"/>
<i>Automatically enters preset time</i>	<input type="checkbox"/>	<input checked="" type="checkbox"/>	<input checked="" type="checkbox"/>
<i>Remains in same mode after cook cycle</i>	<input type="checkbox"/>	<input type="checkbox"/>	<input checked="" type="checkbox"/>

# OPERATING INSTRUCTIONS (Continued)

## Starting Up

### YOU DO THIS

1) Press **On** for ½ second.

2) Allow 10 to 30 minutes for oil to reach operating temperature (350°F or 177°C).

### LCD

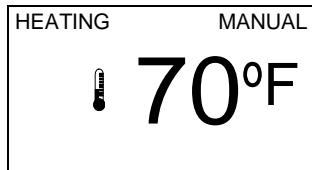

### PERFECT FRYER DOES THIS

- 1) Now in **HEATING** mode
- 2) Oil temperature rising to operating temperature
- 3) Once operating temperature is reached, now **READY** to start cooking

## Manual Mode

- 1) Put food in basket
- 2) Open door and slide out drawer
- 3) Set basket on basket lift
- 4) Slide in drawer and close door

5) Enter cook time and press **Start**  
ex: **1 3 0 Start**

- 6) Wait for "Beep"
- 7) Open door and slide out drawer
- 8) Remove basket

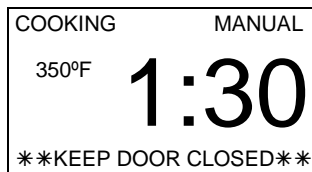

- 1) Brief pause, basket engages with spin motor briefly then lowers into oil
- 2) **COOKING** cycle begins
- 3) Fryer counts down time remaining
- 4) **COOKING** cycle is complete
- 5) Basket raised out of oil
- 6) **SPINNING** cycle begins (time adjustable)
- 7) Fryer "beeps" to let you know that food is cooked
- 8) Fryer returns to **READY** mode

## Preset Times

Cooking Times & Names (factory defaults)								
Preset	Name	Time	Preset	Name	Time	Preset	Name	Time
1	FRENCH FRIES	3:00	4	POPPERS	3:00	7	FISH FILLETS	4:00
2	CHICKEN TENDERS	4:00	5	CHEESE BITES	2:00	8	CHICKEN WINGS	4:00
3	ONION RINGS	2:30	6	CORN DOGS	3:00	9	POTATO WEDGES	3:30

**NOTE:** Pressing **Preset** repetitively will toggle between **MANUAL** mode, **PRESET** mode and **PRESET LOCKED** mode.

**NOTE:** The default presets are programmed and displayed to show you the **PERFECT FRYER's** capabilities. We recommend that you change the presets to match your own requirements. Please refer to pages 31 and 32.

# OPERATING INSTRUCTIONS (Continued)

## Preset Mode

### YOU DO THIS

- 1) Put food in basket
  - 2) Open door and slide out drawer
  - 3) Set basket on basket lift
  - 4) Slide in drawer and close door
  - 5) Press **Preset**
  - 6) Press **1** (for example)  
Cook cycle starts automatically
- Note: You can choose between 9 different presets
- 7) Wait for “Beep”
  - 8) Open door and slide out drawer
  - 9) Remove basket
  - 10) Follow steps 1 through 6 to cook another order this way

### LCD

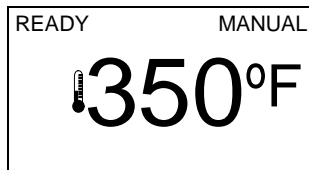
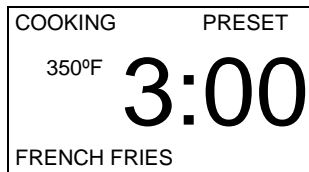
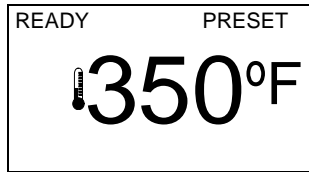

### PERFECT FRYER DOES THIS

- 1) Now in **PRESET** mode
- 2) LCD displays **PRESET**
- 3) LCD displays **FRENCH FRIES** (default setting is 3:00)
- 4) Brief pause, basket lowers into oil
- 5) **COOKING** cycle begins
- 6) Fryer counts down time remaining
- 7) **COOKING** cycle is complete
- 8) Basket raised out of oil
- 9) **SPINNING** cycle begins (time adjustable)
- 10) Fryer “beeps” to let you know that food is cooked
- 11) Fryer returns to **READY** mode
- 12) Fryer returns to **MANUAL** mode

## Preset Locked Mode

- 1) Press **Preset** + **Preset**

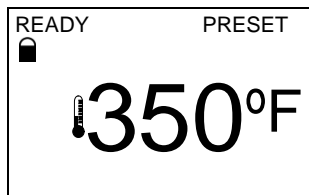

- 2) Put food in basket
- 3) Open door and slide out drawer
- 4) Set basket on basket lift
- 5) Slide in drawer and close door
- 6) Press **2** (for example)  
Cook cycle starts automatically

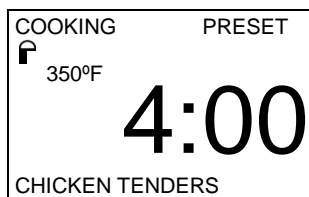

- 7) Wait for “Beep”
- 8) Open door and slide out drawer
- 9) Remove basket
- 10) Follow steps 2 through 6 to cook another order this way

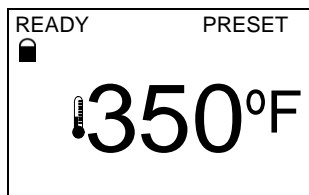

- 1) Now in **PRESET LOCK** mode
  - 2) **PRESET**  is displayed on LCD
  - 3) LCD displays 4:00 (for example)
  - 4) Brief pause, basket lowers into oil
  - 5) **COOKING** cycle begins.
  - 6) Fryer counts down time remaining
  - 7) **COOKING** cycle is complete
  - 8) Basket raised out of oil
  - 9) **SPINNING** cycle begins (time adjustable)
  - 10) Fryer “beeps” to let you know that food is cooked
- Note: Still in **PRESET LOCK** mode



## OPERATING INSTRUCTIONS (Continued)

### Cooking Time Correction

<u>YOU DO THIS</u>	<u>LCD</u>	<u>PERFECT FRYER DOES THIS</u>
1) Enter incorrect cooking time (2:30 instead of 1:30 for example)	<div style="border: 1px solid black; padding: 5px;">           COOKING                      MANUAL  <div style="font-size: 2em; font-weight: bold; text-align: center;">2:30</div> </div>	1) Brief pause, basket lowers into oil
2) Press <b>2 3 0</b> <b>Start</b>		2) <b>COOKING</b> cycle begins.
		3) Fryer counts down time remaining
3) Press <b>Cancel</b>	<div style="border: 1px solid black; padding: 5px;">           PAUSE                              MANUAL            350°F                      <div style="font-size: 2em; font-weight: bold; text-align: center;">2:29</div>            PRESS START/CANCEL         </div>	4) <b>COOKING</b> cycle <b>PAUSE</b>
		5) Basket raised out of oil
		6) Use arrow keys to adjust time by 10 second increments if desired
4) Press <b>Start</b> to continue cook cycle or <b>Cancel</b> to end cook cycle	<div style="border: 1px solid black; padding: 5px;">           READY                              MANUAL  <div style="font-size: 2em; font-weight: bold; text-align: center;">350°F</div> </div>	6) If <b>Cancel</b> is pressed spin cycle runs
		7) Time is erased
5) Enter correct cooking time	<div style="border: 1px solid black; padding: 5px;">           COOKING                      MANUAL            350°F                      <div style="font-size: 2em; font-weight: bold; text-align: center;">1:30</div> </div>	7) Brief pause, basket lowers into oil
6) Press <b>1 3 0</b> <b>Start</b>		8) <b>COOKING</b> cycle begins.
		9) Fryer counts down time remaining

### Open Door – Paused Cooking

(Safety and Health regulations require doors and panels to be closed during cooking)

1) Open door during cook cycle	<div style="border: 1px solid black; padding: 5px;">           PAUSE                              MANUAL            350°F                      <div style="font-size: 2em; font-weight: bold; text-align: center;">1:24</div> </div>	1) <b>COOKING</b> cycle <b>PAUSE</b>
		2) Basket raised out of oil
2) Close door and press <b>Start</b> if you want the cooking cycle to continue	<div style="border: 1px solid black; padding: 5px;">           COOKING                      MANUAL            350°F                      <div style="font-size: 2em; font-weight: bold; text-align: center;">1:24</div> </div>	3) Brief pause, basket lowers into oil
		4) <b>COOKING</b> cycle begins
		5) Fryer counts down time remaining
3) Close door and press <b>Cancel</b> if you do not want the cooking cycle to continue	<div style="border: 1px solid black; padding: 5px;">           READY                              MANUAL  <div style="font-size: 2em; font-weight: bold; text-align: center;">350°F</div> </div>	6) Cooking time erased, now in <b>READY</b> mode

## OPERATING INSTRUCTIONS (Continued)

### Standby Mode

SEE THIS LCD

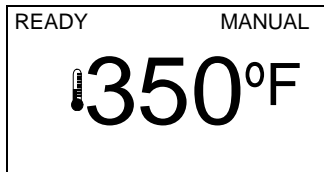

DO THIS

- 1) Press  and  together
- 2) Release both

Note: Temperature will decrease to 275°F (to set default standby temperature, see page 26 for more information)

GET THIS LCD

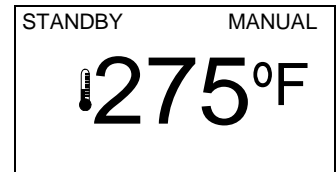

**Note: During slow periods, using standby mode reduces energy costs, allows a quick recovery and minimizes oil breakdown.**

### Shutting Down

YOU DO THIS

TURN YOUR PERFECT FRYER OFF:

- At end of day
- To replace deep fry oil
- To clean
- For other service or maintenance

- 1) Press 

**DO NOT UNPLUG FRYER  
Fans must remain ON  
during COOLDOWN mode**

LCD

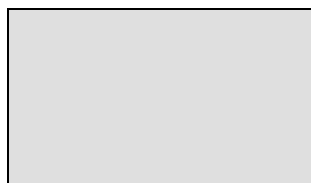
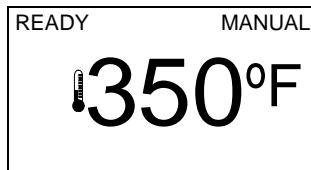

PERFECT FRYER DOES THIS

- 1) Now in **READY** mode
- 2) Now in **COOLDOWN** mode
- 3) No power to heater element
- 4) Fans continue to cool fryer
- 5) Fryer counts down temperature
- 6) LCD backlighting goes off
- 7) Temperature decreases to 122 °F (50°C)
- 8) Fans stop
- 9) LCD goes blank
- 10) Your PERFECT FRYER is off

# USER DEFINED OPTIONS

## CUSTOMIZE YOUR PERFECT FRYER WITH YOUR OWN SETTINGS

- CTS™ Cook Time Sensitivity
- Temperature read-out: °C or °F
- Preset Cooking Times
- Cooking Oil Standby Temperature
- Count of Cook Cycles
- Cooking Oil Temperature
- Basket Drain Time
- Sound Volume
- And Much More

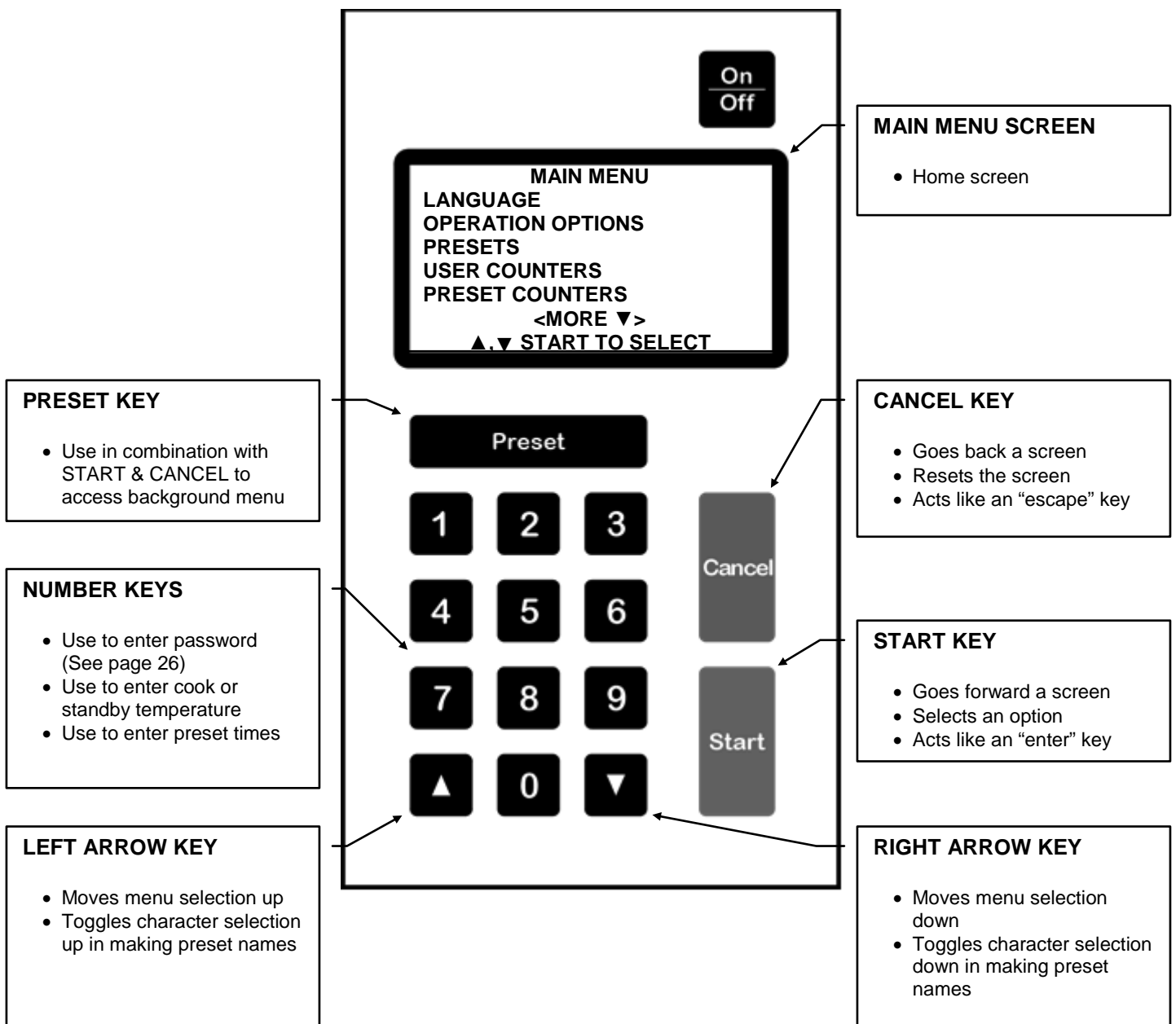

## USER DEFINED OPTIONS (Continued)

### Background Menu - Accessing

<u>SEE THIS LCD</u>	<u>DO THIS</u>	<u>GET THIS LCD</u>
<p>READY MANUAL</p> <p style="font-size: 2em; text-align: center;">350°F</p>	<p>1) Press <b>Cancel Start Preset</b> together</p> <p>2) Release together</p>	<p>SFC VER.: 6.X.X FRYER SN# XXXXX</p> <p>ENTER PASSWORD:</p> <p>▶</p>
<p>SFC VER.: 6.X.X FRYER SN# XXXXX</p> <p>ENTER PASSWORD:</p> <p>▶*****</p>	<p>3) Press <b>4 7 5 0 Start</b></p>	<p style="text-align: center;"><b>MAIN MENU</b></p> <p>LANGUAGE OPERATION OPTIONS PRESETS USER COUNTERS PRESET COUNTERS &lt;MORE ▼&gt; ▲, ▼ START TO SELECT</p>
<p style="text-align: center;">MAIN MENU</p> <p>LANGUAGE <b>OPERATION OPTIONS</b> PRESETS USER COUNTERS PRESET COUNTERS &lt;MORE ▼&gt; ▲, ▼ START TO SELECT</p>	<p>4) Scroll down to the desired menu selection and press <b>Start</b></p>	<p style="text-align: center;"><b>OPERATION OPTIONS</b></p> <p>WAIT MODE <input type="checkbox"/> STANDBY MODE <input checked="" type="checkbox"/> PRESET MODE <input checked="" type="checkbox"/> BUZZER VOLUME 9 KEY VOLUME 4 &lt;MORE ▼&gt; ▲, ▼ START TO SELECT</p>

### CTS™ (Cook Time Sensitivity)

- CTS™ adjusts cooking time to compensate for the drop in cooking oil temperature when a basket of product is placed into the fryer. CTS™ increases cooking time to accommodate for differences in product moisture content, basket-load size, and initial temperature.
- A proper CTS™ setting will ensure a high quality product. For example; 2 lbs of French fries will cook to the same quality as only 6 ounces of French Fries.
- In addition to having a “global” CTS™ setting under the Operation Options menu for manually entered cook cycles, each preset can be programmed with its own individual setting. This provides for a lot of flexibility among different food products.
- Some experimenting with the range of 1 to 9 may be required to achieve optimum quality. A value of 5 is a good place to start and is the default.
- A setting of 0 means no CTS™ whatsoever.

**OPERATION OPTIONS**

CTS 5  
REMINDER TIME 0M  
MELT CYCLE   
FACTORY SETUP  
<MORE ▼>  
▲, ▼ START TO SELECT

**FRENCH FRIES**

CTS: 5  
SPIN TIME: 30  
SPIN SPEED: 350  
<MORE ▲>  
▲, ▼ START TO SELECT

### Background Menu - Map

#### LANGUAGE

- ENGLISH (factory default)
- ESPANOL
- FRANCAIS

**LANGUAGE**

ENGLISH   
ESPANOL   
FRANCAIS   
▲, ▼ START TO SELECT

## USER DEFINED OPTIONS (Continued)

### OPERATION OPTIONS

#### ➤ WAIT MODE

- When , will not allow cooking until oil has reached operating temperature
- Default is

#### ➤ STANDBY MODE

- When , gives user ability to put fryer into standby mode
- This is an energy saving feature which holds oil temperature at desired standby temperature
- Default is

OPERATION OPTIONS	
WAIT MODE	<input type="checkbox"/>
STANDBY MODE	<input checked="" type="checkbox"/>
PRESET MODE	<input type="checkbox"/>
BUZZER VOLUME	9
KEY VOLUME	4
<MORE ▼>	
▲, ▼ START TO SELECT	

#### ➤ BUZZER VOLUME

- Intensity of “beep” for finish of cook cycle and system errors
- Choose between 0 and 9
- Default is 9

#### ➤ KEY VOLUME

- Intensity of “beep” when a key is pressed
- Choose between 0 and 9
- Default is 4

#### ➤ UNITS

- Temperature of oil in the vat
- Choose between °C (Celsius) and °F (Fahrenheit)

OPERATION OPTIONS	
UNITS	°F
SPIN TIME	30S
SPIN SPEED	350
COOK TEMP	350°F
STANDBY TEMP	275°F
<MORE ▼>	
▲, ▼ START TO SELECT	

#### ➤ SPIN TIME

- Time a basket of cooked food spins out of the oil before you hear the “beep”
- Choose between 0 and 60 seconds

#### ➤ SPIN SPEED

- Peak RPM of basket during spin cycle
- Choose between 0 and 500 RPM (in 50 rpm intervals)

#### ➤ COOK TEMPERATURE

- Operating temperature of the oil
- Choose between 275°F (135°C) and 375°F (190°C)  
Note: Between 350°F and 360°F is ideal. If the temperature is set too low, the food will absorb too much oil and taste greasy. If the temperature is set too high, the food will cook too quickly on the outside and will be too dark once the inside is cooked. It may also cause the oil to breakdown quicker and cause smoking.
- Default is 350°F (177°C)

#### ➤ STANDBY TEMPERATURE

- Oil temperature when fryer is in standby mode
- Choose between low (ambient room temperature) and high (cook temperature)
- Default is 275°F (135°C)

#### ➤ LCD CONTRAST

- Visibility of screen
- Choose between 0 and 9

OPERATION OPTIONS	
LCD CONTRAST	0
CTS	5
REMINDER TIME	0M
MELT CYCLE	<input type="checkbox"/>
FACTORY SETUP	
<MORE ▲>	
▲, ▼ START TO SELECT	

#### ➤ CTS™ COOK TIME SENSITIVITY

- Adjusts cooking time to compensate for drop in cooking oil temperature when basket of product is placed into fryer. Refer to page 26 for more information.

## USER DEFINED OPTIONS (Continued)

### ➤ REMINDER TIME

- Time elapsed after cook cycle is finished
- Reminds operator to remove product after it has finished cooking
- “Beeps” and displays “PRODUCT READY” on LCD
- Choose between 0 and 99 minutes
- Default is 0 (disabled)

### ➤ MELT CYCLE

- When , fryer will gradually melt solid blocks of shortening until temperature reaches 212°F (100°C). It is designed to prevent scorching shortening and overheating element.
- Press  to cancel and heat regularly. **DO NOT CANCEL IF USING SOLID SHORTENING!**
- Default is

## PRESETS

- 1: FRENCH FRIES
- 2: CHICKEN TENDERS
- 3: ONION RINGS
- 4: POPPERS
- 5: CHEESE BITES
- 6: CORN DOGS
- 7: FISH FILLETS
- 8: CHICKEN WINGS
- 9: POTATO WEDGES

PRESETS	
1: FRENCH FRIES	3:00
2: CHICKEN TENDERS	4:00
3: ONION RINGS	2:30
4: POPPERS	3:00
5: CHEESE BITES	2:00
<MORE ▼>	
▲, ▼ START TO SELECT	

PRESETS	
6: CORN DOGS	3:00
7: FISH FILLETS	4:00
8: CHICKEN WINGS	4:00
9: POTATO WEDGES	3:30
<MORE ▲>	
▲, ▼ START TO SELECT	

### Preset properties that can be changed (refer to page 31)

- TIME
  - Cook Cycle Time
- TEMP
  - Cook Cycle Temperature
- NAME
  - Preset Name
- CTS
  - Cook Time Sensitivity (refer to page 26)
- SPIN TIME
  - Spin Time in seconds
- SPIN SPEED
  - Spin Speed in RPM

FRENCH FRIES	
TIME:	3:00
TEMP:	350°F
NAME:	FRENCH FRIES
<MORE ▼>	
▲, ▼ START TO SELECT	

FRENCH FRIES	
CTS:	5
SPIN TIME:	30
SPIN SPEED:	350
<MORE ▲>	
▲, ▼ START TO SELECT	

## USER DEFINED OPTIONS (Continued)

### USER COUNTERS

- COOK TIME
  - Accumulated cook cycle time in hours
- NUMBER OF CYCLES
  - Accumulated number of cook cycles
- ON TIME
  - Accumulated on time in hours
- RESET ALL
  - To reset all values to 0

USER COUNTERS	
COOK TIME:	0HR
NO. CYCLES:	0
ON TIME:	0HR
RESET ALL	
▲,▼ START TO SELECT	

### PRESET COUNTERS

- NUMBER OF CYCLES
  - Accumulated number of cook cycles
- RESET ALL
  - To reset all values to 0

PRESET COUNTERS	
1: FRENCH FRIES	115
2: CHICKEN TENDERS	230
3: ONION RINGS	138
4: POPPERS	221
5: CHEESE BITES	121
<MORE ▼>	
▲,▼ START TO SELECT	

PRESET COUNTERS	
6: CORN DOGS	32
7: FISH FILLETS	56
8: CHICKEN WINGS	223
9: POTATO WEDGES	61
RESET ALL	
<MORE ▲>	
▲,▼ START TO SELECT	

### TOTAL COUNTERS

- COOK TIME
  - Accumulated cook cycle times in hours, cannot be reset
- NUMBER OF CYCLES
  - Accumulated number of cook cycles, cannot be reset
- ON TIME
  - Accumulated on time in hours, cannot be reset

TOTAL COUNTERS	
COOK TIME:	0HR
NO. CYCLES:	0
ON TIME:	0HR
▲,▼ START TO SELECT	

## USER DEFINED OPTIONS (Continued)

### OPERATION TESTS (for service personnel)

- FANS
  - Use the arrow keys to turn fans on and off (note: oil temperature must be below 122°F (50°C))
  - Monitor rpm and current values of each fan
- INTERLOCKS
  - To view interlocks and if they're open or closed
  - = Open,  = Closed
- BASKET
  - Use the arrow keys to move arm up and down
  - Monitor current values of motor
- DRAWER
  - Use the arrow keys to move arm up and down
  - Monitor current values of motor
- HEATER
  - For factory heater calibration. **Do not adjust.**
- DISPLAY
  - Use START and CANCEL to turn all the pixels of the LCD on and off
- CIRCUIT BOARD
  - Monitor the circuit board temperature
- SPIN MOTOR
  - Turn the spin motor on and off and check different RPMs

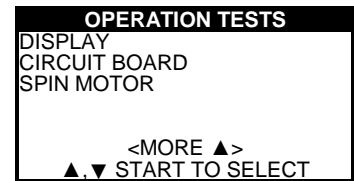
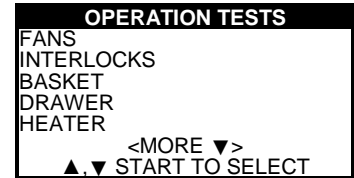

### SET DEFAULTS

- Press start to reset options and presets to factory defaults
- PRESETS and UNITS will not change

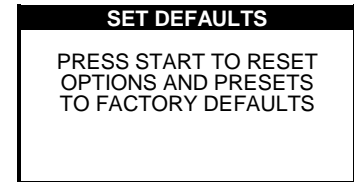

## Option Changes (Example °F to °C)

### SEE THIS LCD

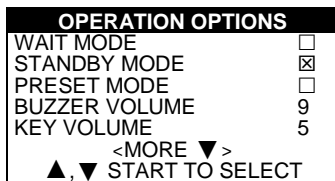

### DO THIS

- 1) From OPERATION OPTIONS menu, scroll down to UNITS using key
- 2) Press **Start**

### GET THIS LCD

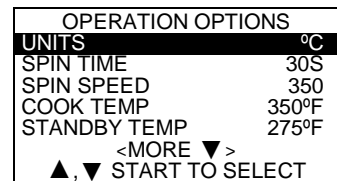

**Note: All OPERATION OPTIONS menu items can be customized by following this basic procedure (some use the arrow keys).**



# USER DEFINED OPTIONS (Continued)

## Customizing Presets

### SEE THIS LCD

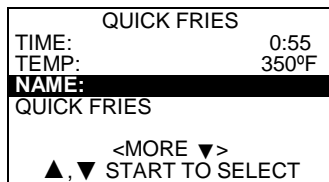
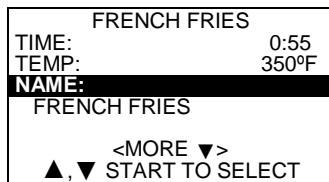
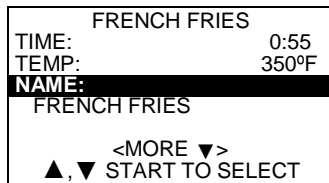
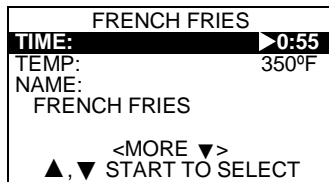
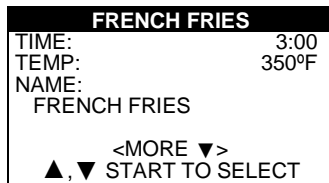
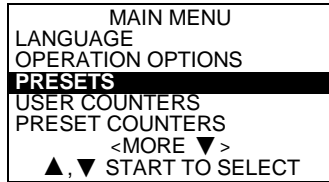

### DO THIS

- 1) From main menu, scroll down to PRESETS using ▼ key
- 2) Press **Start**
- 3) Change PRESET 1's settings by scrolling down using the ▼ key
- 4) Press **Start**
- 5) Change PRESET 1's cook time by scrolling down using the ▼ key
- 6) Press **Start**
- 7) Set new COOK TIME (ex: 55 seconds)
- 8) Press **55 Start**
- 9) Change PRESET 1's name by scrolling down with the ▼ key
- 10) Press **Start**  
(A small cursor appears under first letter of the name PRESET 1.)
- 11) To change character above small cursor, use the ▼ and ▲ keys
- 12) Press **Start** to move forward
- 13) Press **Cancel** to move back
- 14) To enter your selection, press **Start** after underscore mark ( \_ ) appears
- 15) "QUICK FRIES" will now appear on bottom left of LCD during PRESET modes

### GET THIS LCD

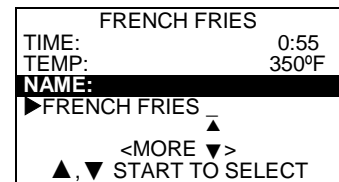
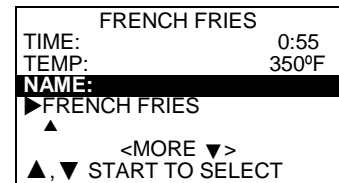
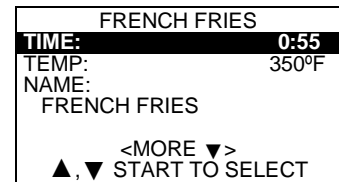
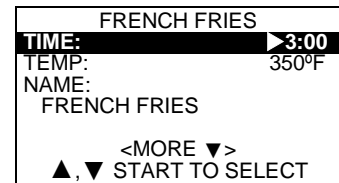
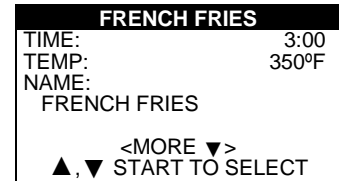

Note: maximum 20 characters

## USER DEFINED OPTIONS (Continued)

### Customizing Presets on the Front Label

Used in conjunction with your custom programmed presets (please refer to page 31), easily identify your own custom presets by using the supplied label page. Simply follow the steps below:

- 1) Remove preset slider (default presets are located on front and custom preset label template is located on back).
- 2) Choose preprinted labels or create your own label from supplied label sheet.
- 3) Apply labels to preset slider in proper preset box (up to 9 labels corresponding to 9 programmed presets may be used on preset slider).
- 4) Install preset slider under preset menu label by starting from bottom (moving fryer to edge of counter may make this easier).

- 1** Preset Label Menu
- 2** Preset Slider
- 3** Preset Labels

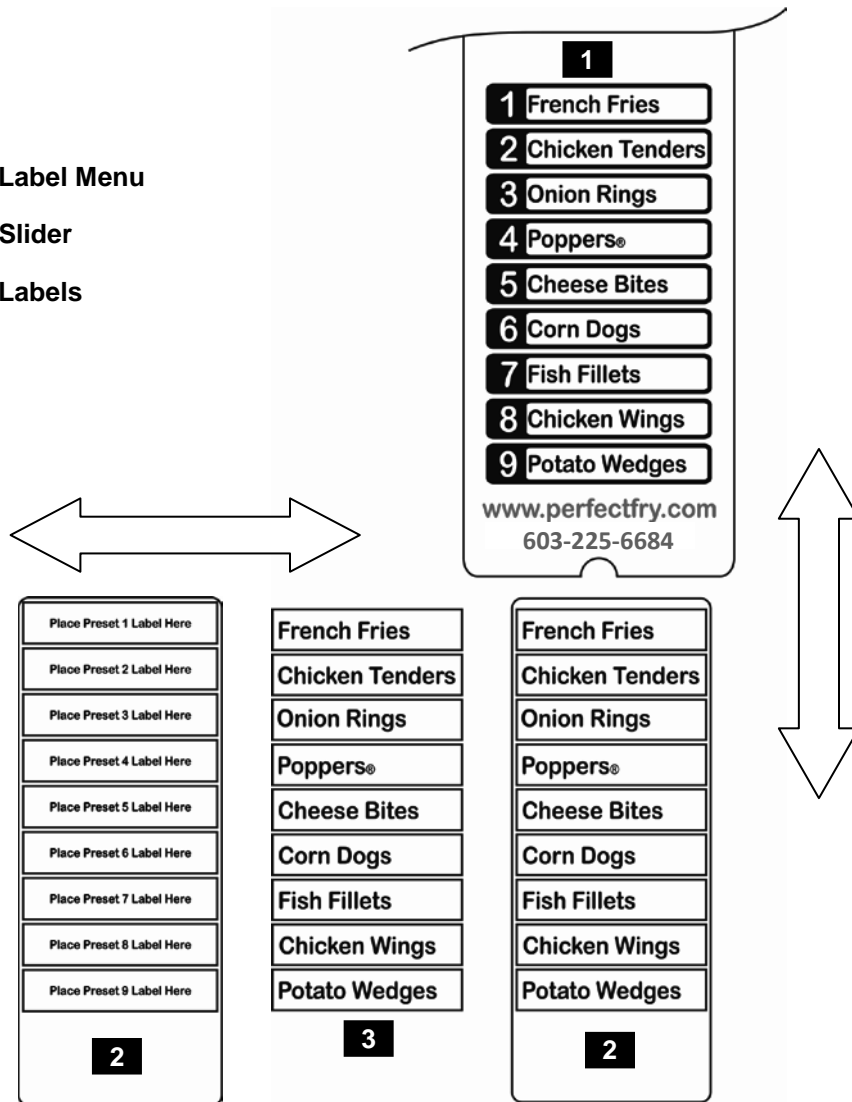

# HELP

- Your PERFECT FRYER “beeps” twice to signal an error condition. When the error condition is corrected, two beeps signal OK.
- It is possible to have more than one SYSTEM ERROR displayed at the same time. When that happens, all error conditions will be displayed on the LCD. All must be corrected.
- When a SYSTEM ERROR condition exists, the PERFECT FRY de-energizes the heating element, but the fans continue to run.
- When there appears to be a problem, but no SYSTEM ERROR message is displayed, refer to the trouble-shooting table on page 34. If the solution suggested doesn't solve the problem, call your service rep. or PERFECT FRY at 603-225-6684.

## System Error Conditions

SEE THIS LCD	CAUSED BY DO THIS	GET THIS LCD
<p><b>*** SYSTEM ERROR ***</b> PLEASE CHECK FRONT PANEL</p>	<ul style="list-style-type: none"> <li>• <i>Hinged front panel is not installed or shut properly</i></li> <li>• Check to see that front panel is closed securely with two black latches</li> </ul>	<p>HEATING MANUAL</p> 
<p><b>*** SYSTEM ERROR ***</b> PLEASE CHECK FILTER PLACEMENT</p>	<ul style="list-style-type: none"> <li>• <i>Air filter cartridge is not installed properly</i></li> <li>• Check to make sure cartridge is properly installed (↑↑ up) in air filter cage, and cage is securely latched in place</li> </ul>	<p>HEATING MANUAL</p> 
<p><b>*** SYSTEM ERROR ***</b> PLEASE CHECK GREASE FILTER</p>	<ul style="list-style-type: none"> <li>• <i>Grease filter is not installed properly</i></li> <li>• Check to see that it sits in grease tray (magnet on right hand end of grease filter), and that filter and tray are properly installed in filter chamber</li> </ul>	<p>HEATING MANUAL</p> 
<p><b>*** SYSTEM ERROR ***</b> PLEASE CHECK HEATER BOX</p>	<ul style="list-style-type: none"> <li>• <i>Heating Element is not installed properly</i></li> <li>• Check to see that heater module has been properly placed on oil vat</li> <li>• Check to see the electrical connection between heater module and connector is made at inside back of fryer compartment</li> <li>• Clean the male and female terminals on connector with rubbing alcohol and cotton swab.</li> </ul>	<p>HEATING MANUAL</p> 
<p><b>*** SYSTEM ERROR ***</b> PLEASE CHECK AIRFLOW/AIR FILTER</p>	<ul style="list-style-type: none"> <li>• <i>There is improper air flow</i></li> <li>• Make sure air intake (front) and exhaust (rear) vents are not obstructed</li> <li>• Clean grease filter thoroughly</li> <li>• Replace the air filter cartridge</li> </ul>	<p>HEATING MANUAL</p> 
<p><b>*** SYSTEM ERROR ***</b> PLEASE CHECK FIRE EXTINGUISHER</p>	<ul style="list-style-type: none"> <li>• <i>Loss of pressure in the Fire Extinguisher, system needs to be recharged</i></li> <li>• Call PERFECT FRY at 603-225-6684 for recommended fire Service Company near you.</li> </ul>	<p>HEATING MANUAL</p> 
<p><b>*** SYSTEM ERROR ***</b> PLEASE CHECK PRIMARY OVERTEMP.</p>	<ul style="list-style-type: none"> <li>• <i>Heating Element is not installed properly</i></li> <li>• Check to see that heater module has been properly placed on oil vat</li> <li>• Check to see the electrical connection between heater module and connector is made at inside back of fryer compartment</li> <li>• Clean the male and female terminals on connector with rubbing alcohol and cotton swab.</li> </ul>	<p>HEATING MANUAL</p> 

**HELP (Continued)**

SEE THIS LCD	CAUSED BY DO THIS	GET THIS LCD
<p><b>*** SYSTEM ERROR ***</b>  <b>PLEASE CHECK</b>            SECONDARY OVERTEMP.</p>	<ul style="list-style-type: none"> <li>• <i>Cooking oil level is too low.</i></li> <li>• Make sure oil level is between the hot and cold lines at rear of vat.</li> <li>• <i>Cooking oil has overheated.</i></li> <li>• Press  and  keys together and release to reset</li> <li>• Is it possible the heater module was submerged in water? If so, call 603-225-6684</li> </ul>	<p>HEATING MANUAL</p> 
<p><b>*** SYSTEM ERROR ***</b>  <b>PLEASE CHECK</b>            MAIN FAN</p>	<ul style="list-style-type: none"> <li>• <i>Main ventilation fan is not functioning properly</i></li> <li>• Check main ventilation fan to see if it is moving air and the fan blades are moving</li> <li>• Remove obstruction and/or check electrical connection</li> </ul>	<p>HEATING MANUAL</p> 
<p><b>*** SYSTEM ERROR ***</b>  <b>PLEASE CHECK</b>            CONTROL FAN</p>	<ul style="list-style-type: none"> <li>• <i>Control fan is not functioning properly</i></li> <li>• Check control fan to see if it is moving air and the fan blades are moving</li> <li>• Remove obstruction and/or check electrical connection</li> </ul>	<p>HEATING MANUAL</p> 
<p><b>*** SYSTEM ERROR ***</b>  <b>PLEASE CHECK</b>            EBOX FAN.</p>	<ul style="list-style-type: none"> <li>• <i>Electronics box fan is not functioning properly</i></li> <li>• Check main ventilation fan to see if it is moving air and the fan blades are moving</li> <li>• Remove obstruction and/or check electrical connection</li> </ul>	<p>HEATING MANUAL</p> 
<p><b>*** SYSTEM ERROR ***</b>  <b>PLEASE CHECK</b>            BASKET MOTOR</p>	<ul style="list-style-type: none"> <li>• <i>Basket motor has been obstructed</i></li> <li>• Check for cause of obstruction before returning fryer to normal use</li> <li>• Correct cause of obstruction</li> <li>• Press  and  keys together and release to reset</li> </ul>	<p>HEATING MANUAL</p> 

**HELP (Continued)****Trouble-shooting Table**

<b>“PROBLEM”</b>	<b>PROBABLE CAUSE</b>	<b>PROBABLE SOLUTION</b>
Won't turn ON when you press the  key	<ol style="list-style-type: none"> <li>1) Not plugged in</li> <li>2) Circuit breaker or fuse</li> <li>3) Wiring</li> </ol>	<ol style="list-style-type: none"> <li>4) Plug in fryer</li> <li>5) Check circuit breaker or replace fuse</li> <li>6) Make sure PERFECT FRYER is plugged in according to its electrical specifications (see page 5)</li> </ol>
ON but will not heat	<ol style="list-style-type: none"> <li>1) Connector on heater module</li> <li>2) Electronics box module</li> </ol>	<ol style="list-style-type: none"> <li>1) Replace heater module</li> <li>2) Replace electronics box module</li> </ol>
Baskets will not lower into or rise out of cooking oil.	<ol style="list-style-type: none"> <li>1) Basket lift (in drawer) not working</li> <li>2) Motor not working</li> </ol>	<ol style="list-style-type: none"> <li>1) Make sure that the drawer is installed properly (see page 11)</li> <li>2) Check wiring</li> <li>3) Replace Motor</li> </ol>
Outer surface is unusually hot	<ol style="list-style-type: none"> <li>1) Dirty grease filter</li> <li>2) Air filter cartridge plugged</li> <li>3) Fans not operating</li> </ol>	<ol style="list-style-type: none"> <li>1) Remove and clean grease filter</li> <li>2) Replace air filter cartridge</li> <li>3) Check rear of fryer for air flow</li> </ol>
Cooking oil spills into spill tray, excessively	<ol style="list-style-type: none"> <li>1) Too much oil in vat</li> <li>2) Too much ice or water in food</li> <li>3) Too much food in basket</li> <li>4) Oil has reached end of its life</li> </ol>	<ol style="list-style-type: none"> <li>1) Remove some oil (when oil is cold it should not be above cold oil line inside vat)</li> <li>2) Cook only frozen foods recommended for use in deep fryers; remove excess ice from food before placing food in basket</li> <li>3) Do not fill food above top of basket</li> <li>4) Change oil</li> </ol>
Food floats out of basket	<ol style="list-style-type: none"> <li>1) Too much cooking oil in vat.</li> </ol>	<ol style="list-style-type: none"> <li>1) Remove some oil; do not fill above cold oil line.</li> </ol>
Excessive smoking	<ol style="list-style-type: none"> <li>1) Oil has “broken down”</li> <li>2) Moisture</li> </ol>	<ol style="list-style-type: none"> <li>1) Replace the cooking oil</li> <li>2) Too much moisture or ice crystals</li> </ol>
Excessive foaming	<ol style="list-style-type: none"> <li>1) Soap residue</li> <li>2) Oil has “broken down”</li> </ol>	<ol style="list-style-type: none"> <li>1) Rinse parts with vinegar solution</li> <li>2) Replace the cooking oil</li> </ol>
Too much noise/vibration from spin basket	<ol style="list-style-type: none"> <li>1) Basket is not loaded evenly</li> </ol>	<ol style="list-style-type: none"> <li>1) Load basket evenly</li> </ol>

# PFS AUTOMATIC EXTINGUISHER

**Note: Please refer to the PFS Automatic Extinguisher Installation, Inspection, Maintenance & Recharge Manual (L20-361) for more detailed information.**



**The PFS must be stored above 32°F (0°C)**

## 1. GENERAL DESCRIPTION

The PFS consists of a cylinder assembly (with pressure switch and gauge), actuating lever, fusible link assembly, manual pull station, and two nozzles. It is designed and acceptable for use in areas that have ambient conditions between 32°F (0°C) and 120°F (50°C).

## 2. OPERATION

### Automatic Operation

Upon the detection of a fire, the PFS will automatically operate. The fusible link rated at 280°F (138°C) will operate when exposed to the fire and operate the PFS automatic extinguisher unit. When operated, the PFS unit will discharge wet chemical agent through the provided discharge piping and distribution nozzles.

### Manual Operation

The PFS unit can also be operated manually by pulling the remote lever (to be mounted on the front of the cooking appliance) that is clearly marked “In Case Of Fire - PULL”.

### IMPORTANT:

The manual pull handle is to be pulled **ONLY IN CASE OF FIRE** in the **PERFECT FRYER** (use when the automatic system has failed).



**NOTE:** Power shut-off is also achieved by system operation. If the pressure in the cylinder(s) drops below 92 psi (63 bar), the pressure switch opens, deactivating the power relay causing the appliance to de-energize.

## 3. INSPECTION & MAINTENANCE

The PFS must be serviced on a regular basis. Three types of servicing are required:

### Monthly

An inspection or “quick check” must be conducted by the owner/operator and include verification of the following:

- 1) The PFS is in its proper location.
- 2) The PFS shows no physical damage or condition that might prevent operation.
- 3) The pressure gauge is in the green operating range.
- 4) The maintenance tag is in place and is up to date.
- 5) The manual pull is unobstructed.
- 6) The nozzle blow-off caps are intact and undamaged.

### Semi-Annually

The system must be inspected by authorized service personnel, as per NFPA 17A and include the following:

- 1) A check to see that the hazard has not changed.
- 2) Examination of the fusible link, cylinder, tubing, nozzles and all auxiliary equipment.
- 3) Fusible links must be replaced at least annually from the date of installation. They must be destroyed when removed. They need to be replaced with the proper rated link (6GT587). A fusible link loaded with grease or other material can result in an excessive delay in actuation.
- 4) Verification that the agent distribution piping is not obstructed. Remove the blow-off caps (6GT014) from the nozzles to ensure that they are free of grease build-up and inspect them for deterioration. Replace them as necessary.

# PFS AUTOMATIC EXTINGUISHER (Continued)

## Inspection and Maintenance

### Semi-Annually (continued)

- 5) Where semi-annual maintenance of any wet chemical containers or PFS components reveals conditions such as, but not limited to, corrosion or pitting in excess of manufactured limits, structural damage or fire damage, repairs by soldering, welding, or brazing, the affected part(s) shall be replaced or hydrostatically tested. The hydrostatic testing of wet chemical containers shall follow the applicable procedures outlined in NFPA 17A.
- 6) All wet chemical systems must be tested for proper operation. A discharge of the wet chemical is normally not part of the test. Simply remove one lead from the pressure switch to initiate appliance shut-down.
- 7) Where the maintenance of the PFS reveals defective parts that could cause an impairment or failure of proper operation of the PFS, the affected parts must be replaced or repaired.

- 8) The maintenance report, with recommendations if any, shall be filed with the owner or with the designated party responsible for the PFS.
- 9) The PFS must have a tag or label indicating the month and year the maintenance is performed and identifying the person performing the service. Only the current tag or label must remain in place.

### Twelve Years

Maintenance must be done by authorized service personnel, as per NFPA 17A and include the following:

- 1) The wet chemical extinguishing agent must be removed and discarded.
- 2) The cylinder needs to be hydrostatically tested to 300 psi (21 bar).
- 3) If the cylinder shows no signs of rupture or distortion, recharge the PFS as directed in the recharging instructions.

### SEMI-ANNUAL INSPECTION & MAINTENANCE (I & M) LOG: PERFECT FRY Serial No. \_\_\_\_\_

Date _____	I & M by _____	Date _____	I & M by _____
Date _____	I & M by _____	Date _____	I & M by _____
Date _____	I & M by _____	Date _____	I & M by _____
Date _____	I & M by _____	Date _____	I & M by _____
Date _____	I & M by _____	Date _____	I & M by _____
Date _____	I & M by _____	Date _____	I & M by _____
Date _____	I & M by _____	Date _____	I & M by _____
Date _____	I & M by _____	Date _____	I & M by _____
Date _____	I & M by _____	Date _____	I & M by _____
Date _____	I & M by _____	Date _____	I & M by _____
Date _____	I & M by _____	Date _____	I & M by _____
Date _____	I & M by _____	Date _____	I & M by _____

# BLOW-APART DIAGRAM & PARTS LIST

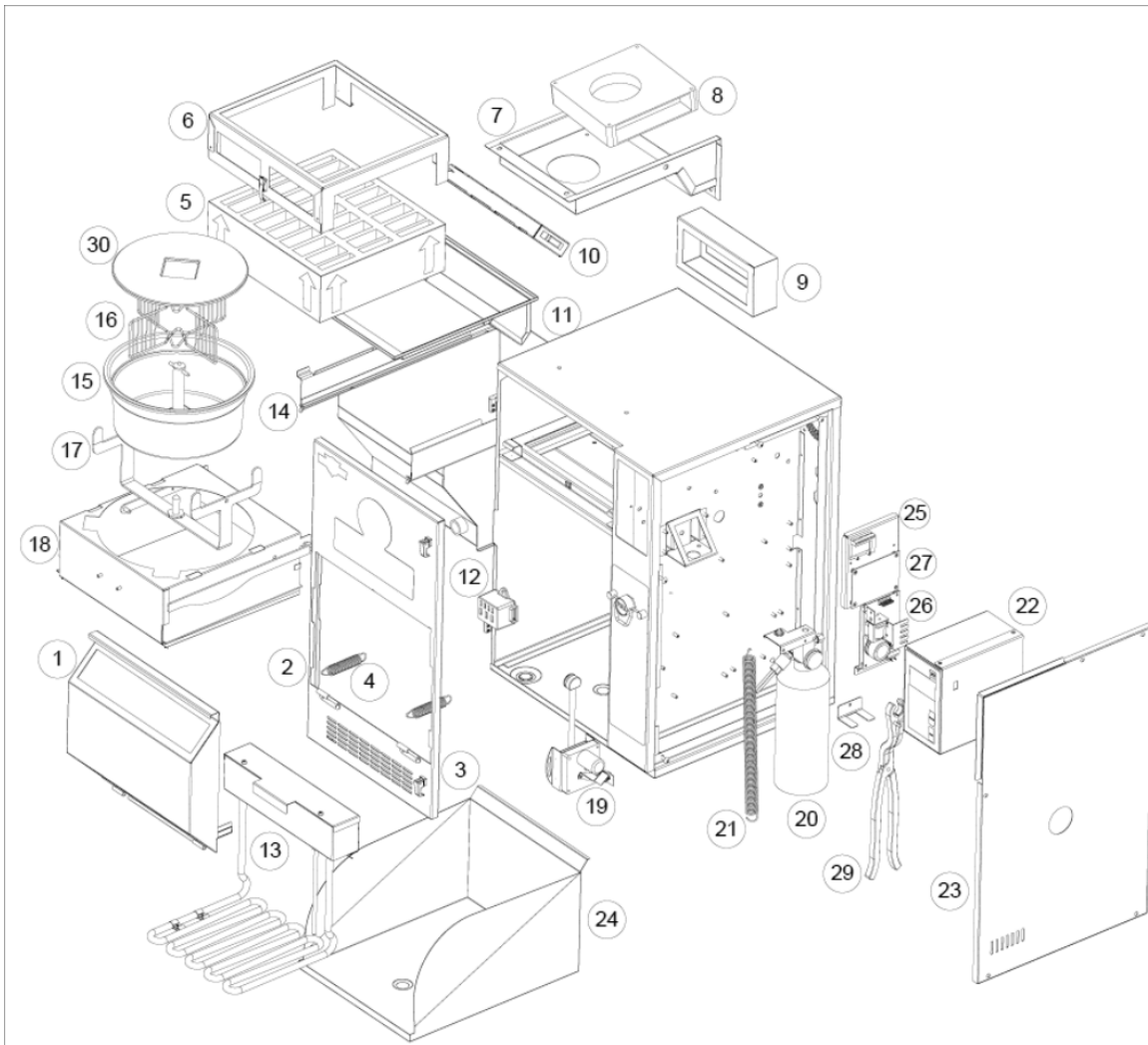

ITEM	DESCRIPTION	PART #
1	Front Door	6SS011
2	Front Panel	6SS010
3	Latch and turn Latches	6HT503
4	Kit, Door Springs	2DT957
5	Air Filter Cartridge	2FU803
6	Filter Cage	6ST730
7	Air Flow Module	2HT723
8	Kit, Main Fan	6HT576
9	Fire Damper	6HT588
10	Grease Filter Assembly	3HT727
11	Grease Filter Tray	6ST728
12	Female Connector Assembly	3CT765
13	Heater Module – 5700W	8ET900
NS	Heater Module – 3750W	2ET763
NS	Heater Module – 3000W	2ET762
NS	Heater Module – 1875W	2ET747
14	8L Oil Vat	6SS003
NS	Door Switch	6HT566
NS	Front Panel Switch	6HT567
NS	Airflow Switch	6HT646
NS	Gasket, Front Perimeter	6HT710
NS	Feet	6HV026

ITEM	DESCRIPTION	PART #
15	Spinfresh Basket	6HS002
16	Quad-Insert – SPINfresh	6HS017
17	Basket Lift, Cradle Assembly	6SS009
18	Housing, Drawer Assembly	6SS004
19	Motor, Module SFC	2HS001
20	PFS Fire System	2GT001
21	Extension Spring - PFS	6GT674
22	Electronics Box Module	2WS802
23	Control Access Panel	6SS020
24	Oil Spill Tray	6SS002
25	Board, Drive Stepper SFC	6WS002
26	Board, Power Supply SFC	6WS001
27	Board, Rotary Encoder SFC	3WT008
28	Hanger, Handle	6SS025
29	Handle, Basket	6HS013
30	Cover, Basket SF	6HS016
NS	Motor, Spin SFC	6HS001
NS	Blow Off Cap	6GT569
NS	Kit, Control Fan	2DT952
NS	Mini Lift Off Hinges	6HT500
NS	Air Filter Switch Assembly	3HT724
NS	Grease Filter Switch	6HT566

NS = NOT SHOWN



# THE PERFECT FRY 1 2 3 WARRANTY

**1** year **Labor**

During the first year after purchase, all labor required in repairing or replacing a defective part will be provided free of charge.

**2** years **Parts**

During the first 2 years after purchase, all parts of the fryer which prove to be defective in materials or workmanship will be replaced free of charge (parts only).

**3** years **Electronics**

During the first 3 years after purchase, if the electronics module proves to be defective in materials or workmanship, it will be replaced free of charge (parts only).

## TERMS OF WARRANTY

- 1) Perfect Fry Company LLC warrants this fryer to be free from defects in materials and workmanship and will repair or replace it at Perfect Fry Company LLC's option for a period of two years after purchase providing the purchaser follows the manufacturer's recommended procedures for operation and maintenance contained in this manual. Perfect Fry Company LLC shall not be liable for injury or damage to property other than this fryer.
- 2) The warranty applies to materials at the factory for two years (3 years electronics) and labor for one year from date of purchase. The warranty does not include materials and labor employed in cleaning the fryer. Any and all transportation and shipping charges and expenses are the responsibility of the Purchaser. The warranty card must be completed and registered with Perfect Fry Company LLC within 30 days of purchase to validate the warranty. The warranty will cease to exist if maintenance has not been performed according to the manufacturer's instructions. This warranty does not cover damage arising from or caused by improper maintenance, directly or indirectly, transportation, accident, misuse, improper installation, fire, flood, or acts of God. Parts repaired or replaced under this warranty are warranted throughout the remainder of the original warranty period only. The warranty does not apply to parts and service supplied or obtained from other than Perfect Fry or its authorized distributors.
- 3) Other than the warranty expressed in clause 1) hereof, Perfect Fry Company LLC expressly disclaims all conditions and warranties, express or implied, including, without limitation, the implied warranties of merchantability and fitness for a particular purpose. Perfect Fry shall not be responsible for, nor does this warranty extend to, any consequential or incidental damages or expenses of any kind or nature, regardless of the cause thereof or any knowledge which Perfect Fry may have regarding the probability of the occurrence of such damages or expenses including, without limitation, injury to persons or property, loss of life, loss of use of the products, lost goodwill, loss of income, lost resale profits, work stoppage, impairment of other goods, breach of contract, negligence or such other actions as may be deemed or alleged to be the cause of a loss or damage.



**Perfect Fry Company LLC.**  
**Mailing Address: P.O. Box 501, Concord, NH 03302-0501**  
**Shipping Address: 10 Ferry St., Concord, NH 03301**

**Tel: 603-225-6684**  
**Fax: 603-225-8472**  
**General Information: [profits@perfectfry.com](mailto:profits@perfectfry.com)**  
**Customer Support: [service@perfectfry.com](mailto:service@perfectfry.com)**  
**Web: [www.perfectfry.com](http://www.perfectfry.com)**

© 2012 PERFECT FRY COMPANY LLC  
PRINTED IN USA  
L20-396 R0