

INSTALLATION AND OPERATION INSTRUCTIONS

DUAL ZONE BACK BAR CABINET — SELF CONTAINED

MODEL NOS.

BSDZ Series

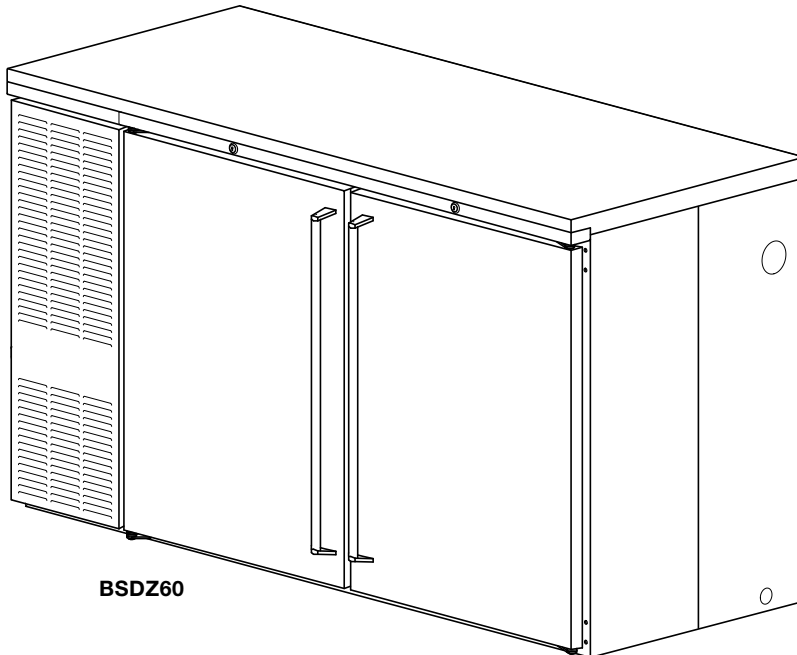

BSDZ60

IMPORTANT INFORMATION

To register your product, visit our web site at (www.perlick.com). Click on “Commercial”, then “Service”. You will see the link to “Warranty Registration Form”. You must complete and submit this form or the installation date will revert back to the ship Date.

This manual has been prepared to assist you in the installation of your Cabinet and to acquaint you with its operation and maintenance.

We dedicate considerable time to ensure that our products provide the highest level of customer satisfaction. If service is required, your dealer can provide you with a list of qualified service agents. For your own protection, never return merchandise for credit without our approval.

We thank you for selecting a Perlick product and assure you of our continuing interest in your satisfaction.

WARNING: When lifting, the full weight of the cabinet must be supported. Lift from the cabinet base and not from the top. Improper lifting can result in severe damage to the cabinet.

Table of Contents

PREPARING THE CABINET

Specifications.....	2
Tools Required.....	3
Plumbing	3
Electrical.....	3
Uncrating and Inspection.....	3
Installing Casters or Legs	3
Placing the Cabinet.....	3
Leveling the Cabinet	3
Installing the Base Plate.....	3
Refrigeration and Temperature Control.....	4
Cleaning the Cabinet.....	4
Cleaning the Condenser	4
Cleaning Stainless Steel.....	4
Replacement Parts.....	5
Reversing Door Hinge	6
Wiring Diagram.....	7



8300 West Good Hope Road • Milwaukee, WI 53223 • Phone 414-353-7060 • Fax 414-353-7069
Toll Free 800-558-5592 • E-Mail: Perlick@Perlick.com • www.Perlick.com

Installation and Operating Instructions

Sizes and Specifications, Dual Zone Back Bar Cabinets – Self Contained

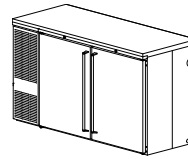

MODEL NOS.		BSDZ60
NUMBER OF DOORS		2
CABINET DIMENSIONS	Length - Inches (mm)	60" (1524)
	Depth - Inches (mm)	24 ³ / ₄ " (629)
	Height - Inches (mm)	34 ¹ / ₂ " (876)
CASE CAPACITY (based on 12 oz. Long Neck bottle)		15
CASE CAPACITY (based on use of full extension wine shelves)		48 bottles (per door)
CONDENSING UNIT H.P.		1/4
RUNNING LOAD –AMPS		5.5
SHIP WT. Lbs. (kg.)		390 (177)
INTERIOR	Door sill: High strength polyethylene. Door pan and ceiling: High strength polystyrene. Floor pan and Walls: Stainless steel. Includes pilasters, (2) vinyl coated shelves and floor rack per door, and interior lights.	
EXTERIOR	Front, back, top and sides stainless steel. Bottom galvanized steel. See optional accessories for door & grille finishes.	
DOOR HINGING	Stainless steel hinges with standard location as illustrated. For special hinging hinge locations starting left to right. Field reversible.	
DOOR HARDWARE	Door handles: Choice of full length stainless steel, classic 6" black vinyl wrapped pull or top mounted stainless steel pull tab. Lock finish: chrome.	
REFRIGERATION	R-134a capillary tube-type. Aluminum fin and copper tube evaporator, epoxy coated coil. Adjustable temperature control for each temperature zone. Self-defrosting. Pull out condensing unit for service and cleaning. Condensing unit and evaporator left side only.	
ELECTRICAL	115V, 60Hz., 1 phase AC. Furnished with 3-prong, 6 foot NEMA5-15 PC cord. Contact Perlick for other voltage/frequency requirements.	
PLUMBING	Evaporator condensate is removed automatically. Optional floor drain with 3/4" NPT at right end or 1" NPS out bottom come plugged from factory.	
INSULATION	Foamed-in-place polyurethane, 2" walls, 1 ¹ / ₂ " top.	
OPTIONAL ACCESSORIES & MODIFICATIONS	<ul style="list-style-type: none"> • Leg set • Laminated top • Laminated ends • Full extension wine shelves • Brass hardware (classic & full length only) • Caster sets • Base plates 	<p>Door finishes</p> <ul style="list-style-type: none"> Black vinyl coated Stainless steel Customer choice of laminate Painted in color of choice Prepared for field lamination Glass door with black vinyl coated frame
		<ul style="list-style-type: none"> Glass door with stainless steel frame Glass door with laminated frame <p>Grille finishes</p> <ul style="list-style-type: none"> Black vinyl coated Stainless steel Customer choice of laminate Painted in color of choice

NOTE: This equipment is intended for the storage and display of non-potentially-hazardous bottled or canned products only.

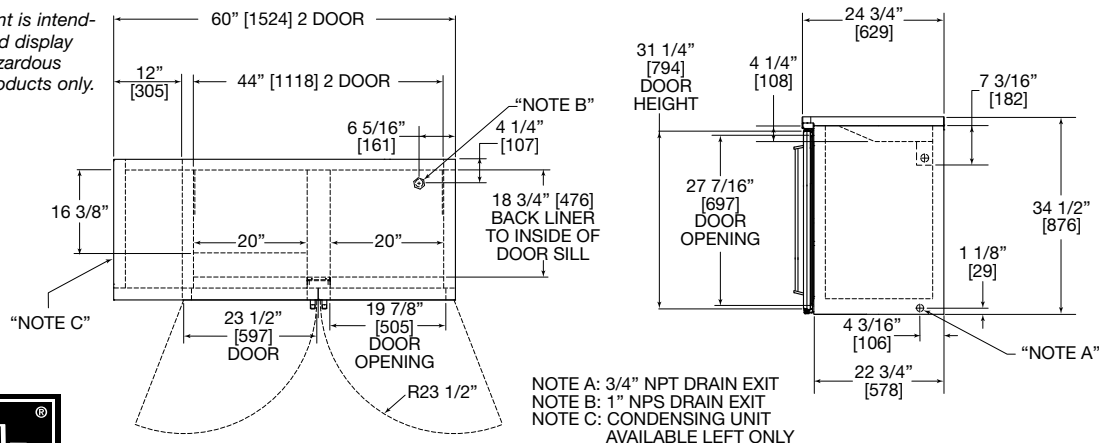

Perlick is committed to continuous improvement. Therefore, we reserve the right to change specifications without prior notice.

Preparing the Cabinet for Use

Suggested Tools

- #2 Phillips Screwdriver.
- 10" Crescent Wrench.
- $\frac{9}{16}$ " Allen Wrench.
- $\frac{5}{16}$ " and $\frac{3}{8}$ " Hex Socket.
- Power Drill or Driver.

Plumbing

No plumbing required. Condensate from the cooling coil is automatically evaporated through a condensate pan located in the side condensing unit compartment.

For your convenience, a factory installed floor drain is located in the back right corner of the cabinet. This can be plumbed to an external floor drain. The floor drain can be plumbed from the cabinet right side using a $\frac{3}{4}$ " NPT connection or out the bottom using a 1" NPS connection. Both ports of the drain come capped from the factory.

Electrical

The cabinet must be connected to a separately fused power source (see electrical specification plate) and grounded in accordance with National and Local Electrical Codes. Caution: Do not attempt to operate the equipment on any other power source than that listed on the Electrical Specification plate.

Uncrating and Inspection

Remove all crating material before operating. Carefully inspect cabinet for hidden damage. If damage is discovered, file your claim immediately with the transportation company. Perlick is not responsible for damage in transit.

Installing Casters or Legs (Optional)

Attach four casters or legs to the cabinet bottom; mount rigid casters at the rear and swivel casters on the front. Use the supplied $\frac{1}{4}$ "- 20 x $\frac{3}{4}$ " hex head self-tapping machine screws.

Installing Base Plate (Optional)

Attach brackets to cabinet bottom in holes provided. Attach base plate to brackets. (See separate instructions, provided with kit). When returning cabinet to upright position, be careful not to bend brackets.

WARNING!

To avoid compressor damage, after returning cabinet to an upright position, let unit stand for 24 hours before plugging it in.

Placing the Cabinet

Push the cabinet into place using rollers when necessary. **Important:** Proper air flow around the condensing unit is necessary for efficient operation. Never obstruct the air flow in and out of the condensing unit.

For sanitation purposes, it may be necessary to seal the base of the cabinet to the floor. This can be accomplished by laying a bead of silicone sealant between the base of the cabinet and the floor as shown by the figure at below.

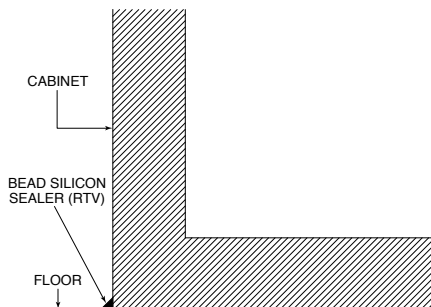

Leveling the Cabinet

When the cabinet is in place, check installation with carpenter's level. When level front to back and left to right, accumulated water will drain out of cabinet evaporator drain.

General Information

Refrigeration and Temperature Control

Each zone has been factory set to maintain the desired temperature specified when ordered. The factory set storage temperatures are as follows:

- Refrigerator — 34° to 38° F
- White wine — 50° to 55° F
- Red wine — 60° to 65° F

Adjusting the Temperature

The temperature control in the left compartment is located on the left side of the evaporator fan panel. The temperature control in the right compartment is located on the top rear partition wall. You will need a flat head screwdriver to turn the adjusting screw on the control. Make small adjustments until the desired temperature is achieved.

- **Colder Temperatures:**
Turn the adjusting screw clockwise (to the right).
- **Warmer Temperatures:**
Turn the adjusting screw counterclockwise (to the left).
- **Temperature Control “OFF”:**
Turn the adjusting screw completely counterclockwise to the “O” position until a click is noted.

The condenser fan motor turns off and on with the compressor. The evaporator fan motor runs continuously. The partition wall fan cycles with the damper assembly.

NOTE:

Cabinet Temperatures lower than 34° will not allow for proper defrosting of the evaporator coil. If defrosting is necessary, remove product from the cabinet and turn the control adjusting screw to the OFF position until coil is defrosted.

Cleaning the Cabinet

Use a mild detergent and water to clean the inside and outside of the cabinet. Dry thoroughly. Never use a scouring pad or abrasive cleanser.

NOTE: An industrial strength, commercial cleaner can be used to clean the outside of painted cabinets.

Cleaning the Condenser

The condenser (located behind the front grille cover) should be inspected every 30 days and cleaned, if necessary.

Use a long handled, stiff brush to clean the dirt from the front surface of the condenser. Keeping the condenser free from dust and dirt will ensure efficient operation.

Failure to keep the condenser clean will cause a loss in condensing unit efficiency, and may damage the compressor.

CAUTION: Do not bend the fins while brushing the front of the condenser.

Recommended Cleaning Agents

JOB	CLEANING AGENT*	COMMENTS
Routine Cleaning	Soap, ammonia, detergent	Apply with sponge or cloth. Can be used on all finishes.
Fingerprints and smears	Areal 20, Lac-O-Nu, Lumin Wash, O’Cedar Cream Polish	Provides barrier film to minimize fingerprints. Can be used on all finishes.
Stubborn stains and Discolorations	Allchem Concentrated Cleaner, Samae, Twinkle, Zud Restoro, Grade F or FFF Italian Pumice, Whiting or Talc, Liquid Nu Steel, Copper’s or Revere Stainless Steel Cleaner, Lumin Cleaner, Sta-Clean, Cameo Copper Cleaner, Allen Polish Highlite, Penny-Brite, Copper Brite	Rub lightly, using dry or damp cloth in the direction of polish lines on the stainless steel.

* Use of propriety names is intended only to indicate a type of cleaner and does not constitute an endorsement. Omission of any proprietary cleaner does not imply its inadequacy. All products should be used in strict accordance with instructions on the package. NOTE: Do Not Use Steel Wool or Scouring Pads to clean stainless steel.



Perlick is committed to continuous improvement. Therefore, we reserve the right to change specifications without prior notice.

Replacement Parts – Dual Zone Back Bar Cabinets

MODEL NOS.	BSDZ60
Complete condensing unit	C22647
Replacement compressor, R134a	513200314UA.2
Condensing unit fan motor assembly	515315009
Condenser Coil	15352019
Terminal board	519100088
Overload protector	US-PB10HBX1
Relay	US-PB10HBX1
Start capacitor	US-PB10HBX1
Fan blade, evaporator	57699
Fan motor, evaporator	C15239A
Fan motor, partition wall	65253
Fan guard, partition wall	65254
Fan guard, evaporator	65557
Temperature control, refrigerator	61283
Temperature control, wine	C12827W
Solenoid, damper	65778
Damper blade, assembly	65783
Evaporator coil	66572
Liquid and suction line assembly	65084
Pan, evaporator	66579-1
Wire harness, compressor bottom	65560
Wire harness, evaporator	65561
Wire harness, partition wall (damper)	65776
Wire harness, light jumper	65538
Wire harness, mullion heater	65571
Light bulb	63821
Light bulb guard	65525
Light socket	63484
Light switch	65535
Lock	63762
Space, lock	63761-1
Lock rail	65432-24SS or 65432-24
Grille, rail	65432-1-12SS or 65432-12
Grille, front	66210-12SS or 66210-12
Condensate pan	65565-1
Panel, end, condensor unit housing	66215-1SS
Panel, rear, condensor unit housing	65435-12SS
Door sill	65500-1
Door handle full length SS	65305-1
Gasket, door	66237-4
Hinge group, right	66264R
Hinge group, left	66264L
Hinge pin	63679-1
Shelf, wire	62307-2
Shelf, wine rack	66413
Clip, shelf	C15875
*Replacement top	RT-NL2
*Replacement door	RD-NL2

*Contact Perlick Milwaukee for complete door and top replacement. Cabinet serial no. required.



Reversing Door Hinge

Tools Required

- #3 Phillips Screwdriver.
- 1/16" Allen Wrench.
- Flathead Screwdriver

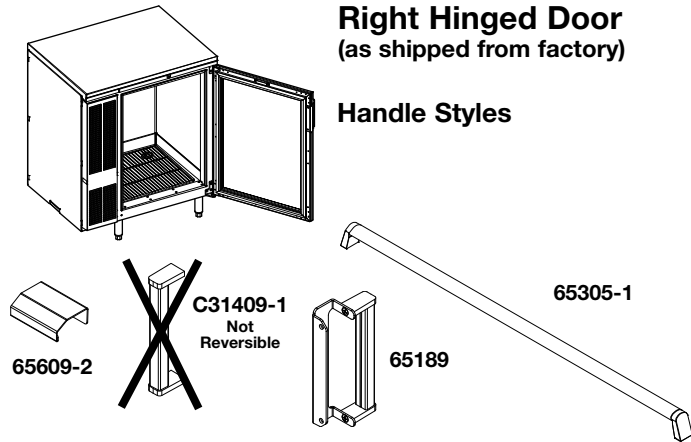

Operations to Perform on Cabinet

STEP 1:

Remove bottom hinge pin from assembly.

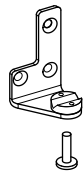

STEP 2:

Carefully lift and tilt out door assembly from the unit and set aside.

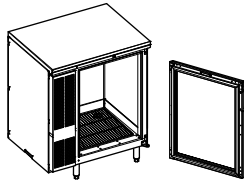

STEP 3:

Remove lock rail from cabinet, requires removal of four screws.

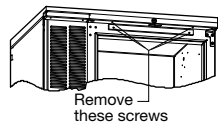

STEP 4:

Remove top hinge pin. Remove top and bottom hinge brackets from the unit.

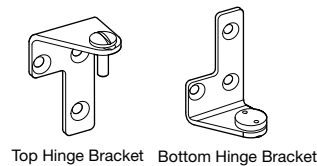

STEP 5:

Remove hinge bushing from bottom hinge bracket and assemble to top hinge bracket.



STEP 6:

Taking care not to scratch the surface, remove hole plugs from the left hinge holes.

STEP 7:

Insert hole plugs into vacant right hinge holes.

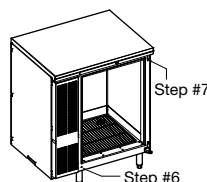

STEP 8:

Re-assemble hinge brackets to unit. Bottom right bracket is assembled as the top left bracket. Top right bracket is assembled as the bottom left bracket.

STEP 9:

Re-insert top hinge pin.

STEP 10:

Re-assemble lock rail from STEP #3

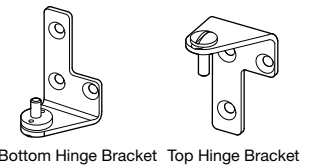

Operations to Perform on Door

STEP 11:

Remove bottom door hinge bracket from door assembly and remove door hinge bushing from bracket. Re-assemble door hinge bracket to previous position, without bushing.

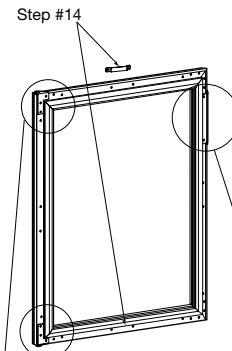

STEP 12:

Remove top door hinge bracket from door assembly and assemble door hinge bushing from STEP 11 to bracket. Re-assemble door hinge bracket to previous position with bushing attached.

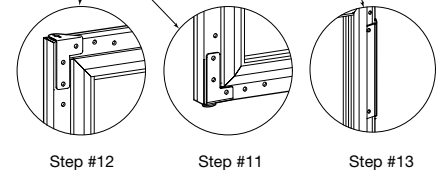

STEP 13:

Door with full length SS handle:

There is no need to remove door handle. It will be positioned correctly when door is reversed.

Door with SS pull tab or handle with wrap-around bracket:

Remove the two screws mounting the handle and reposition to appropriate location on the opposite side of the door.

STEP 14:

Remove lock retainer and install on opposite end of door.

STEP 15:

What was the door top is now the door bottom. Carefully lift the door onto the hinge brackets of the cabinet. The two hinge bushings should meet. Reinsert the bottom hinge pin to complete the door switching operation.



Wiring Diagram – BSDZ60 2 Door Dual Zone Back Bar Cabinet

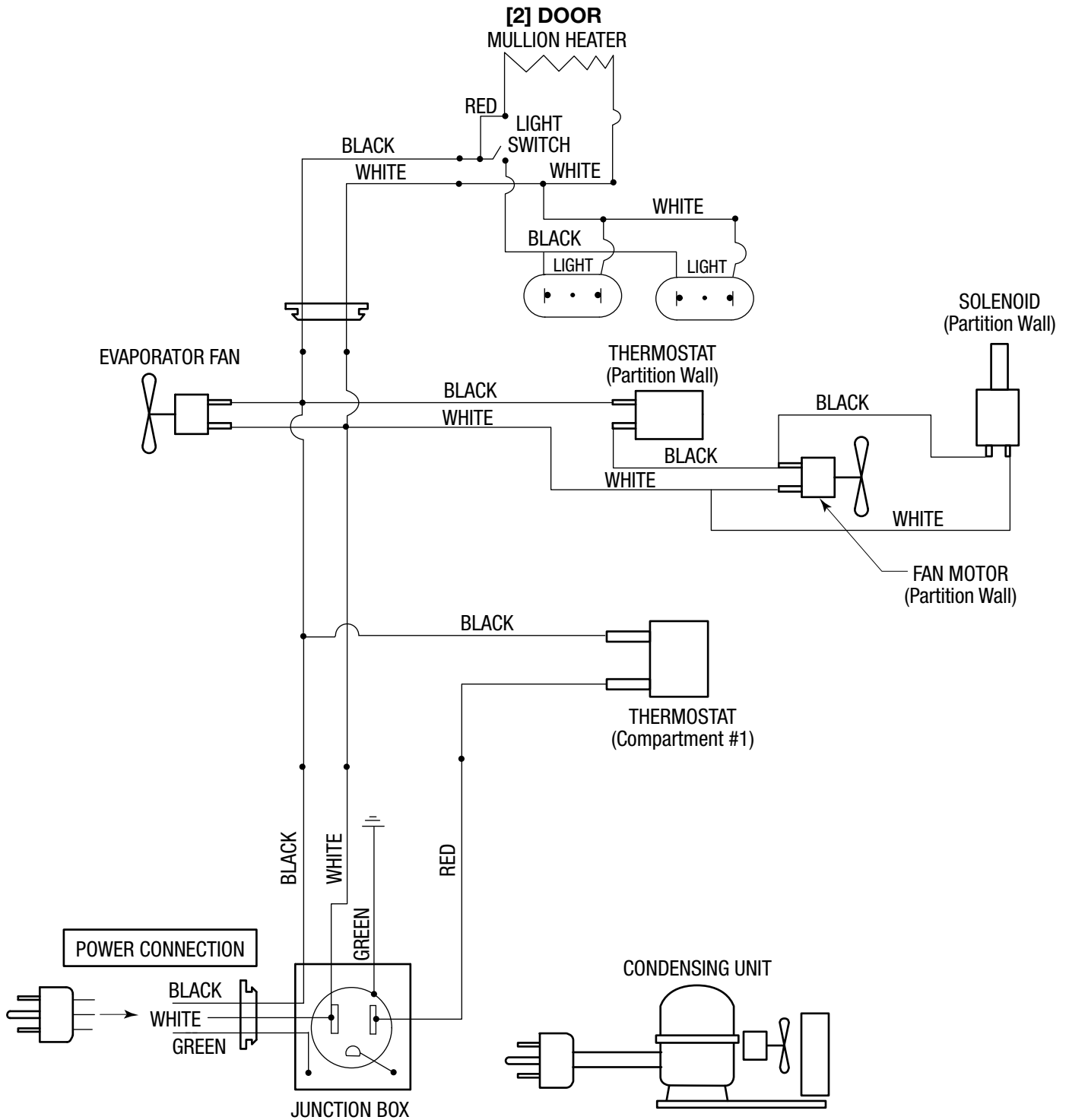



8300 West Good Hope Road • Milwaukee, WI 53223 • Phone 414-353-7060 • Fax 414-353-7069
Toll Free 800-558-5592 • E-Mail: Perlick@Perlick.com • www.Perlick.com