

# INSTALLATION AND OPERATION INSTRUCTIONS CONCESSIONAIRE PORTABLE DISPENSERS

## MODEL NOS.

DC Series

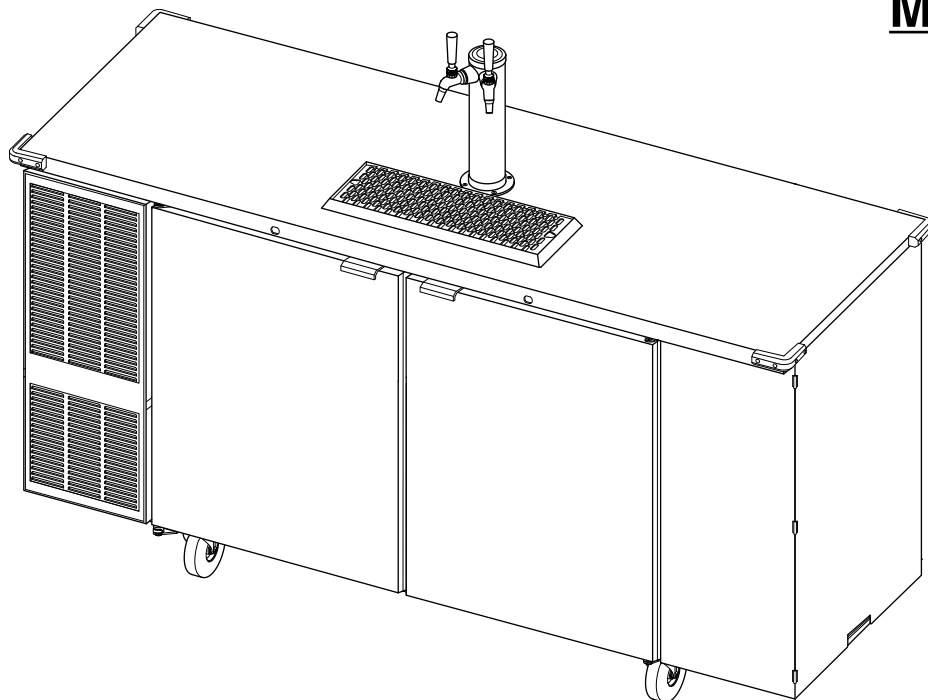

### IMPORTANT INFORMATION

To register your product, visit our web site at ([www.perlick.com](http://www.perlick.com)). Click on “Commercial”, then “Service”. You will see the link to “Warranty Registration Form”. You must complete and submit this form or the installation date will revert back to the ship Date.

This manual has been prepared to assist you in the installation of your Concessionaire Dispenser and to acquaint you with its operation and maintenance.

We dedicate considerable time to ensure that our products provide the highest level of customer satisfaction. If service is required, your dealer can provide you with a list of qualified service agents. For your own protection, never return merchandise for credit without our approval.

We thank you for selecting a Perlick product and assure you of our continuing interest in your satisfaction.

**WARNING: When lifting, the full weight of the cabinet must be supported. Lift from the cabinet base and not from the top. Improper lifting can result in severe damage to the cabinet.**

### Table of Contents

#### Preparing the Cabinet for Use

Specifications.....	2
List of Included Parts.....	3
Tools Required.....	3
Plumbing.....	3
Electrical.....	3
Installing Casters.....	3
<b>Tapping</b>	
Connecting the Keg Coupler.....	4
Tapping the Keg.....	4
Connecting the Regulator.....	5
Adjusting Gas Flow.....	5
CO <sub>2</sub> Leak Test.....	5
Replacing a CO <sub>2</sub> Gas Cylinder.....	5
Handling CO <sub>2</sub> Gas.....	5
<b>Temperature</b>	
Beer Temperature.....	6
<b>Cleaning</b>	
Cleaning the Beer Lines.....	7
Cleaning the Cabinet.....	7
<b>General Information</b>	
How to Pour a Perfect Glass of Beer.....	8
Troubleshooting.....	9
Beer Facts.....	9
Replacement Parts.....	10-11
Wiring Diagram.....	12



8300 West Good Hope Road • Milwaukee, WI 53223 • Phone 414-353-7060 • Fax 414-353-7069  
Toll Free 800-558-5592 • E-Mail: [Perlick@Perlick.com](mailto:Perlick@Perlick.com) • [www.Perlick.com](http://www.Perlick.com)

# Installation and Operating Instructions

## Sizes and Specifications, Concessionaire Dispensers

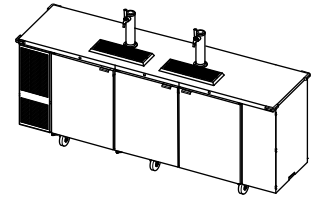
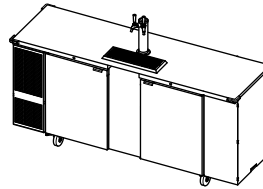
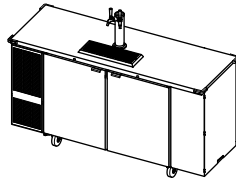

MODEL NOS.	DC72S	DC84S	DC96S	
KEG CAPACITY	2 Keg	3 Keg	4 Keg	
CABINET	Length Ins. (mm)	72" (1829)	84" (2134)	96" (2438)
DIMENSIONS	Depth Ins. (mm)	243/4" (629)	243/4" (629)	243/4" (629)
	w/o BUMPERS	Height Ins. (mm)	341/2" (876)	341/2" (876)
NO. OF DISPENSING HEADS	1	1	2	
NO. FAUCETS	2	2	2	
CONDENSER UNIT H.P.	1/4	1/3	1/3	
RUNNING LOAD - AMPS	5.9	7.5	7.5	
SHIP WT lbs. (kg)	445 (202)	505 (229)	545 (247)	
INTERIOR	<b>Door sill:</b> High strength polyethylene. <b>Door pan and ceiling:</b> High strength polystyrene. <b>Floor pan:</b> Satinless steel. <b>Walls:</b> Galvanized steel.			
EXTERIOR	<b>All Models:</b> The top is stainless steel. The back, front and sides are stainless steel. Bottom is galvanized steel. Doors and grilles are stainless steel.			
REFRIGERATION	R-134a capillary tube-type. Aluminum fin and copper tube evaporator, epoxy coated coil. Forced air into dispensing head. Adjustable temperature control. Self-defrosting. Pull-out condensing unit for service and cleaning.			
VENTILATION	Front ventilated.			
ELECTRICAL	115 Volt, 60 Hz., 1 Phase AC. Furnished with three prong, six foot NEMA5-15P cord. Contact Perlick for other voltage/frequency requirements.			
PLUMBING	Evaporator condensate has been plumbed to a condensate pan located in the compressor housing.			
INSULATION	Foamed-in-place polyurethane; 2" walls, 11/2" top and floor.			
OPTIONAL ACCESSORIES	<ul style="list-style-type: none"> <li>• Keg Couplers</li> <li>• Regulators</li> <li>• Faucet Locks</li> <li>• Optional Dispensing Heads</li> </ul>			

NOTE: This equipment is intended for the storage and display of non-potentially-hazardous bottled or canned products only.

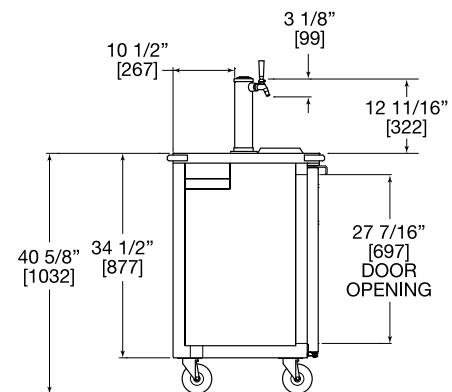
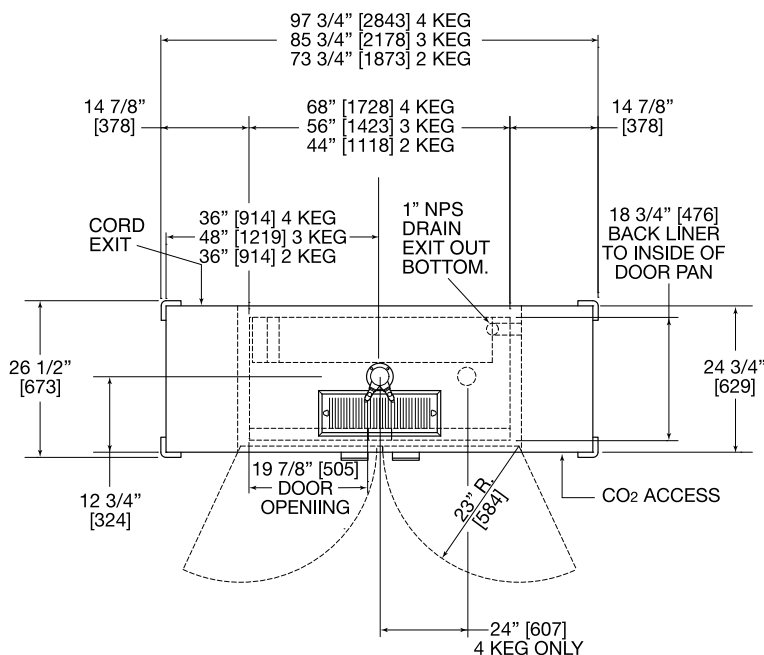

End View

TopView



Perlick is committed to continuous improvement. Therefore, we reserve the right to change specifications without prior notice.

# Preparing the Cabinet for Use – Concessionaire Dispensers

## Parts List

- Faucet Standard.
- Faucet Head Assembly
- Caster Set.
- Black Connector Hose  $\frac{3}{16}$ " x 3'.
- $\frac{5}{16}$ " Air Hose.
- Spanner Wrench.
- Bag of Miscellaneous Parts.

## Tools Required

- #2 Phillips Screwdriver.
- Spanner Wrench (included).
- #10 Crescent Wrench.
- $\frac{9}{16}$ " Allen Wrench.
- $\frac{3}{8}$ " Nut driver.
- Power driver.

## Uncrating and Inspection

Remove all crating material before operating. Carefully inspect cabinet for hidden damage. If damage is discovered, file your claim immediately with the transportation company. Perlick is not responsible for damage in transit.

## Installing Casters

**IMPORTANT:** Attach casters to the cabinet bottom so that caster is centered over cabinet seam. Use supplied  $\frac{1}{4}$ " - 20 x  $\frac{3}{4}$ " hex head self-tapping machine screws.

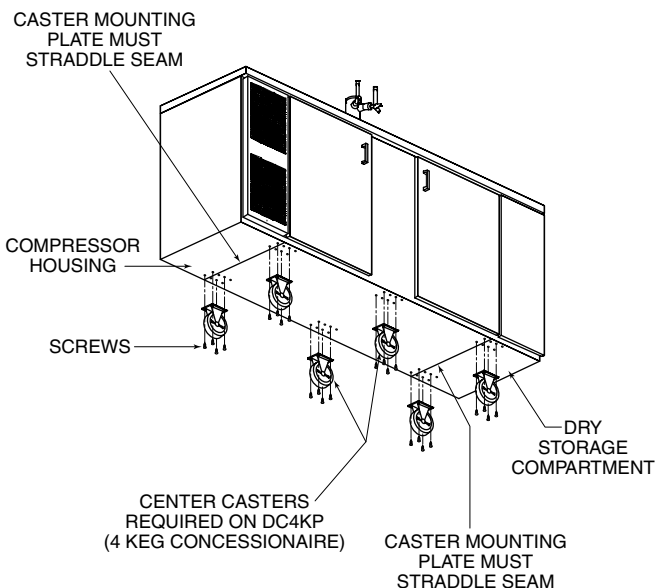

## Plumbing

Connect drain tube from drainer into dump tank.

## Electrical

The cabinet must be connected to a separately fused power source (see electrical specification plate) and grounded in accordance with National and Local Electrical Codes. Caution: Do not attempt to operate the equipment on any other power source than that listed on the Electrical Specification plate.

## Installing the Faucet and Dispensing Head

Before you begin: Wash dispensing head and faucet. Flush beer, dispensing head and faucet lines with fresh water.

- Apply RTV around the base of the dispensing head to seal it to the top. Align the dispensing head over the five holes on the cabinet top and use the five stainless steel #10-32 x  $1\frac{3}{4}$ " Phillips pan head stainless steel machine screws to secure standard to cabinet top. Wipe off excess RTV to complete the seal.
- Attach faucet to standard using spanner wrench to tighten coupling. Attach faucet handle to faucet.
- Insert flexible plastic air hose six to seven inches into bottom of faucet standard. Secure hose with tie wrap (supplied).

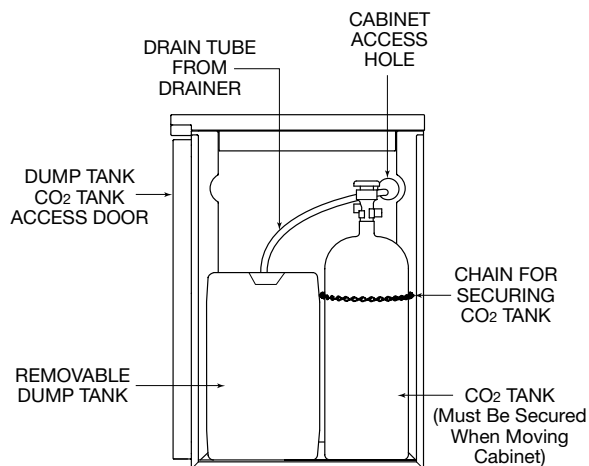

# Installation and Tapping – Concessionaire Dispensers

## Connecting the Keg Coupler (when Supplied by Perlick)

- Place one brown leather washer into black beer line connector hose on hex nut side. Screw connector to stainless steel beverage line on faucet standard. Tighten with a wrench, but do not over tighten.
- Make sure lever handle on the keg coupler is in the **UP** (untapped) position. Place one brown leather washer into wing nut end of black beer line connector hose and thread onto top of keg coupler. Hand tighten.
- Place clamp on one end of red air line. Push end over air valve located inside cabinet. Tighten clamp with screwdriver. Turn shut-off valve to **OFF** (horizontal) position.
- Place clamp on the other end of red air line and push over tailpiece on coupler. Tighten clamp with screwdriver.

**CAUTION:** Do not use keg coupler as a handle to lift keg.

## Tapping a Single Valve Keg (Sankey)



Single Valve Keg Coupler

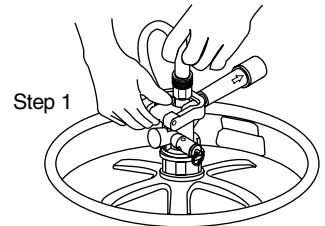

Step 1

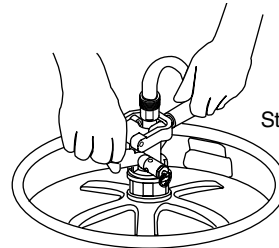

Step 2

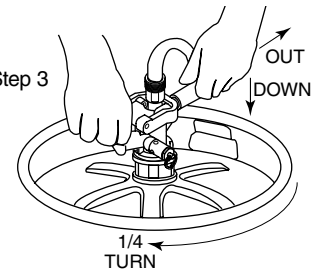

Step 3

- Be sure beer faucet is in closed position.
- Align keg lugs with lug openings on bottom of coupler.
- Turn clockwise 1/4 turn. Pull handle out and down. Keg is now tapped.
- Open shut-off valve on air divider located inside of the cabinet.

**IMPORTANT:** Be sure to close this valve when untapping keg.



# Installation and Tapping – Concessionaire Dispensers

## Connecting the Regulator to the CO2 Cylinder

- Remove blue plug from regulator fitting. (Note: Do not remove the carbonic washer).
- Screw regulator onto gas cylinder valve. Tighten with wrench until vertically straight. Be sure that shut-off valve (**black lever**) on regulator is in the OFF (**horizontal**) position.
- Place a screw clamp over end of red air line and push onto regulator tailpiece. Tighten clamp with a screwdriver.

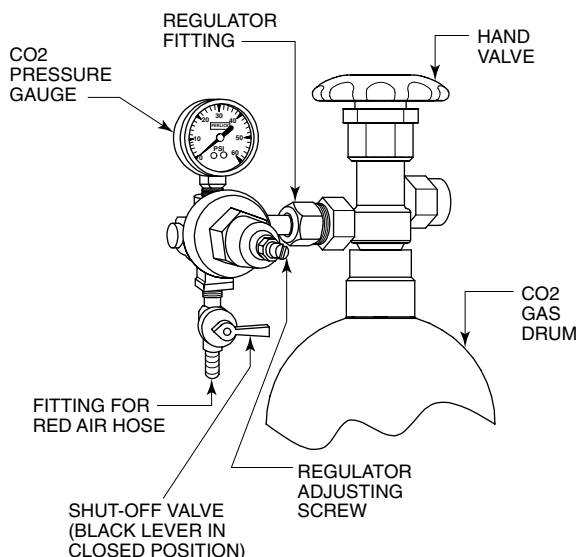

## Adjusting the CO2 Gas Flow

- Turn regulator adjusting screw counterclockwise until it turns freely.
- Turn hand valve counterclockwise on CO2 cylinder to the fully open position.
- Turn regulator adjusting screw clockwise until desired pressure is reached (approximately 12-15 lbs.). Tighten stop nut on adjusting screw.
- Open shut-off valve on bottom of regulator.

## CO2 Leak Test

Dilute a small amount of liquid dishwashing soap and rub the soapy mixture around each connection. If bubbles appear, tighten connection.

## Replacing CO2 Gas Cylinder

- Turn CO2 hand valve clockwise until seated and close shut-off valve on regulator.
- Unscrew regulator from cylinder fitting.
- Replace carbonic washer (Part No. 157F2P), if needed and reattach regulator to filled cylinder.
- Turn CO2 hand valve counterclockwise until fully open. Turn regulator shut-off valve to open position.
- Adjust CO2 gas flow as required, turning clock wise for higher pressure.

## Proper CO2 Handling

### ALWAYS...

- Connect a regulator (reducing valve) to CO2 cylinder.
- Secure cylinder in upright position whether in storage or in use.
- Keep cylinder away from heat. Rupture disc vents at 122° F. maximum.
- Ventilate room after high pressure gas leakage.
- Check the last DOT test date on cylinder neck before filling. If more than five years old, the cylinder must be retested to DOT specifications.
- Be sure CO2 cylinder outlet fitting is free of dust or dirt before attaching regulator.
- Store CO2 cylinder and regulator assembly upright.
- Allow only properly trained and experienced personnel to handle high pressure gas.

### NEVER...

- Connect cylinder directly to a keg without a regulator (reducing valve).
- Drop or throw regulator or CO2 cylinder.
- Transport CO2 cylinder in a closed vehicle.
- Apply oil to a regulator.
- Shut off CO2 cylinder when not in use. You will not save gas by doing so!
- Allow untrained, inexperienced personnel to handle high pressure gas.

**Failure to heed this warning could result in personal injury or death.**

# Draft Beer Information – Concessionaire Dispensers

---

## Temperature

---

One of the most common causes of dispensing problems is improper temperature. Draft beer should be stored at a temperature between 32° and 38°. At warmer temperatures, beer will foam.

At temperatures lower than 30° F., beer will freeze. When beer freezes, the alcohol in the beer may separate and cause the beer to be cloudy with an “off” taste.

### HOW TEMPERATURE AFFECTS DRAFT BEER

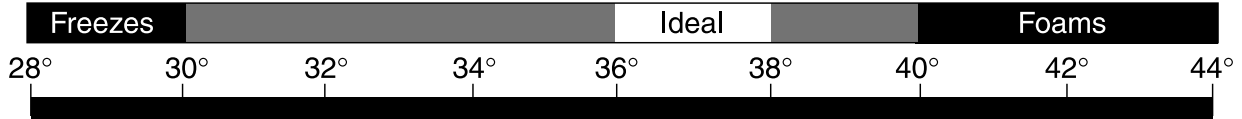

## Refrigeration and Temperature Control

---

The Concessionaire's are equipped with a heavy-duty refrigeration system that is factory set to maintain a product storage temperature of approximately 38° F.

## Adjusting the Temperature

---

The temperature control is inside the cabinet on the right-hand side of the evaporator fan panel assembly. You will need a screwdriver to turn the adjusting screw. Make small adjustments until the desired temperature is achieved.

- **Colder Temperatures:**  
Turn the adjusting screw clockwise (to the right).
- **Warmer Temperatures:**  
Turn the adjusting screw counterclockwise (to the left).

The condenser fan motor turns off and on with the condensing unit. The evaporator fan motor runs continuously. The fan motors are lifetime lubricated and will require no oiling.

### NOTE:

Cabinet Temperatures lower than 34° will not allow for proper defrosting of the evaporator coil. If defrosting is necessary, turn the control knob to the OFF position until coil is defrosted.



Perlick is committed to continuous improvement. Therefore, we reserve the right to change specifications without prior notice.

# Cleaning the Beer System – Concessionaire Dispensers

---

The entire beer system, to include the faucet, flexible beer line and tapping devices must be cleaned at regular intervals. We recommend flushing the entire system with fresh water immediately after a keg has been emptied. Once each month the system should be cleaned chemically.

It is recommended that you purchase Perlick's Pump Type Cleaning Kit. It is equipped with an adapter that attaches directly to the faucet shank, jar with pump, cleaning solution, faucet brush and spanner wrench.

Cleaning the draft beer system will help to eliminate the buildup of the following materials:

■ **Bacteria:**

Beer is an excellent food for bacteria (none of which is harmful). Proper conditions may begin the growth of bacteria in draft beer and on the beer faucet. By regular cleaning, we prevent this bacterial buildup and maintain the quality of the draft beer. Greenish or yellowish colored material on the faucet may indicate bacterial growth.

■ **Yeast:**

All domestic draft beers contain a small amount of yeast which remains in the beer from the fermentation process. When the temperature of draft beer exceeds 50° a process of secondary fermentation may take place. The beer faucet may exhibit a white colored substance (yeast build up) if not cleaned on a regular basis.

■ **Beer Stone:**

All beer contains calcium which is present from the grains used in the brewing process. It is an important natural material in draft systems in that as it oxidizes it coats the internal parts of the beer lines and equipment. This thin coat of beer stone helps prevent the beer from picking up strong metallic or plastic flavors as it flows through the system. The beer stone will continue to build if the system is not cleaned properly or regularly and can cause drawing problems if it begins to flake off. Beer stone is present if one can see a brownish color on the faucet or inner wall of the beer line, or tobacco-like flakes in the beer.

---

## Cleaning the Cabinet

Use a mild detergent and water to clean the inside and outside of the cabinet. Dry thoroughly. Never use a scouring pad or abrasive cleanser.

**NOTE:** An industrial strength, commercial cleaner can be used to clean the outside of painted cabinets.

---

## Cleaning the Condenser

Use a long handled, stiff brush to clean the dirt from the front surface of the condenser. Keeping the condenser free from dust and dirt will ensure efficient operation.

**CAUTION:** Do not bend the fins while brushing the front of the condenser.

# Pouring a Perfect Glass of Beer – Concessionaire Dispensers

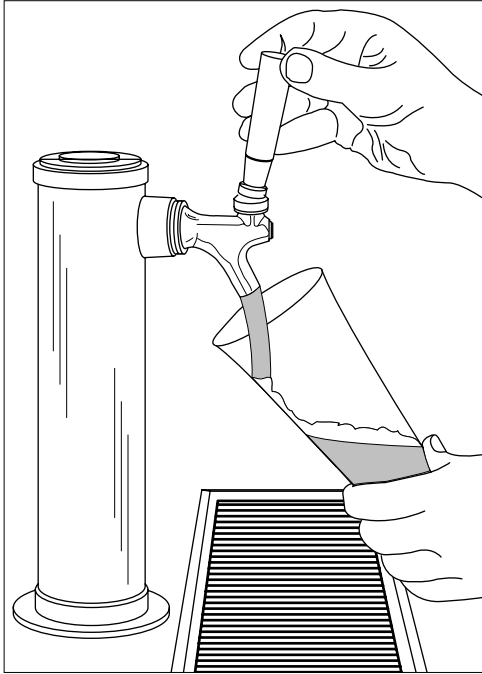

## STEP 1

Start with a clean glass. Place the glass at a 45° angle, one inch below faucet. Do not let the glass touch the faucet. Open the faucet all the way.

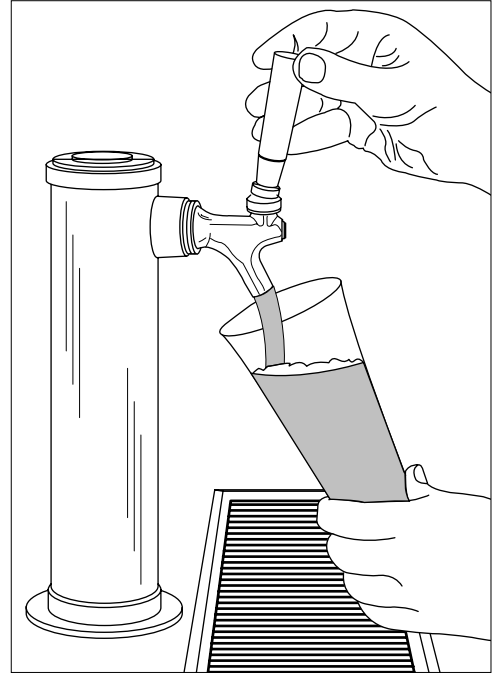

## STEP 2

After the glass has reached half full, gradually bring the glass to the upright position

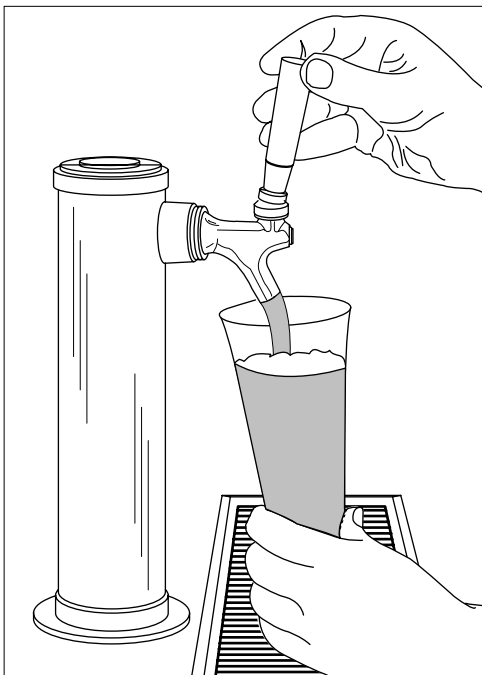

## STEP 3

Let the remaining beer run straight down the middle of the glass. This ensures proper release of CO<sub>2</sub> by producing a ¾" to 1" foam head.



## STEP 4

Close the faucet quickly and completely.



Perlick is committed to continuous improvement. Therefore, we reserve the right to change specifications without prior notice.



# Trouble Shooting – Concessionaire Dispensers

## Beer Service Problems

### ■ Wild Beer:

Dispensed beer has either too much foam or is all foam.

#### CAUSES:

- Beer has been dispensed improperly.  
**Solution:** See pouring instructions on page 8.
- Regulator pressure is set too high.
- Warm keg temperature.

**Solution:** Keg must be colder than 40°. Target temperature is between 36° and 38° F.

- Cabinet door is opened and closed frequently and temperature is warmer than 38° F.  
**Solution:** Adjust temperature to between 36° and 38° F.
- Kinks, dents or obstructions in the line.
- Using oddly shaped glasses. Frosted, waxed or styrofoam containers may cause foaming.
- Dispenser has been turned off for a long period of time.
- Faucet is bad, dirty or in a worn condition.
- Regulator malfunction.

### ■ Flat Beer:

Foamy head disappears quickly; beer lacks brewery fresh flavor.

#### CAUSES:

- Dirty glassware.
- CO<sub>2</sub> pressure is too low, due to leak or pressure setting.
- CO<sub>2</sub> is turned off at night.
- Cooler is too cold.
- CO<sub>2</sub> leak or defective (sticking) check valve.
- Sluggish CO<sub>2</sub> regulator.

### ■ Cloudy Beer:

Beer in glass appears hazy, not clear.

#### CAUSES:

- Dirty glass.
- Dirty faucet or beer line.
- Frozen or nearly frozen beer.
- Old beer.
- Beer that has not been refrigerated for a long period of time.

## Beer and CO<sub>2</sub> Facts

KEG SIZE	NO. OF GALLONS	NO. OF OZ.	NO. OF CASES	NO. OF 12OZ. SERVINGS	FULL KEG WEIGHT
Quarter	7¾	992	3.445	105	87 lbs.
Half	15½	1,984	6.889	210	161 lbs.

- Beer foam is 25% liquid beer and 75% CO<sub>2</sub> gas. Don't waste it!
- Most people prefer beer stored at 38° F.
- Beer lines and faucets require regular cleaning (see cleaning instructions on page 7).
- A fully-charged 4.2 lb. CO<sub>2</sub> cylinder will dispense approximately 5½ to 6½ half barrels.
- CO<sub>2</sub> gas gives beer its sparkling effervescence. It also gives beer its creamy head of foam.

# Replacement Parts – Concessionaire Dispensers

MODEL NOS.	DC72S	DC84S	DC96S
<b>Condensing Units</b>			
Condensing unit 115 volt, 60 hz.	C22647	C22646	C22646
Condensing unit	515301063	515301062	515301062
Compressor	513200314	513200003	513200003
Fan motor assembly	515315009	515315009	515315009
Condenser coil	15352019	15352019	15352019
Terminal board	519100088	519100088	519100088
Overload protector	US-PB10HBX1	US-PB12HBX1	US-PB12HBX1
Relay	US-PB10HBX1	US-PB12HBX1	US-PB12HBX1
Capacitor	US-PB10HBX1	US-PB12HBX1	US-PB12HBX1
<b>Evaporator Assembly</b>			
Self Contained complete	65555-1	65555-2	65555-2
Evaporator coil	C17511-1EP	C17511-2EP	C17511-2EP
Liquid & Suction line	65084	65085	65085
Fan blade	57699	57699	57699
Fan motor	C15239A	C15239A	C15239A
Evaporator fan guard	65557	65557	65557
Temperature control	61283	61283	61283
Bulb clamp	C6634	C6634	C6634
Wire harness, compressor bottom	65560	65560	65560
Wire harness, evaporator	65561	65561	65561
Lock	63762	63762	36762
Space, lock	63761-1	63761-1	63761-1
Lock rail	65432-24SS	65432-24SS	65432-24SS
Grille rail	65432-12SS	65432-12SS	65432-12SS
Condenser pan	65565-1	65565-1	65565-1
Condenser end panel	66215-1SS	66215-1SS	66215-1SS
Grille, black	66210-12	66210-12	66210-12
Grille, SS	66210-12SS	66210-12SS	66210-12SS
Condenser housing back	65435-12SS	65435-12SS	65435-12SS
Evaporator, liquid & suction line cover	65576-1L	65576-4L	65576-2L
Evaporator pan	65526-1	65526-2	65526-2
Door sill	65500-1	65500-1	65500-1
Door handle	65609-2	65609-2	65609-2
Door gasket	66237-4	66237-4	66237-4
Cabinet hinge group left	66264L	66264L	66264L
Cabinet hinge group right	66264R	66264R	66264R
Hinge pin	63679-1	63679-1	63679-1
*Replacement door	RD-NL2	RD-NL2	RD-NL2
Waste tank	65559	65559	65559
Corner bumper	C31726	C31726	C31726
Air distributor assembly	C18942	C18943	C18944
Drainer insert	65510-1	65510-1	65510-1
Waste bin cover	66210-12C	66210-12C	66210-12C



Perlick is committed to continuous improvement. Therefore, we reserve the right to change specifications without prior notice.

# Replacement Parts – Concessionaire Dispensers

## For Single Valve Keg Coupler (Series D)

ITEM NO.	PART NO.	DESCRIPTION
1	32499	Probe assembly
2	F40184	Probe body
3	31080-2P	Ball
4	43641-1	Ball retainer
5	31087-2P	Probe washer
6	31089	“O” Ring - 3-per assembly
7	43061	Body
8	23682-2P	Check valve
9	157R2P	Washer
10	206B-1	Tailpiece
11	2026	Coupling nut
12	31088-2P	Bottom seal washer
13	31084-1	Retaining screw
14	43002A	Yoke assembly w/lock
15	43001A	Yoke assembly standard
16	32474-1	Wrench

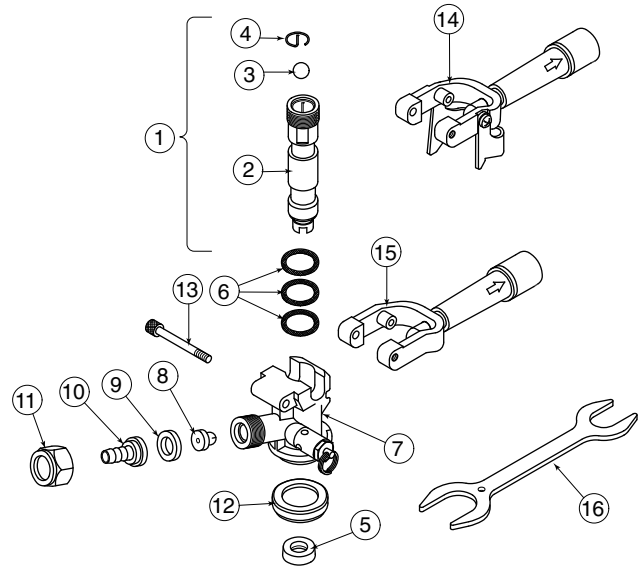

## Micellaneous

PART NO.	DESCRIPTION
157L2P	Beer line connector gasket
57F2P	CO <sub>2</sub> tank washer
1392R	Red air hose
529	Beer hose
2928D	Twin gauge CO <sub>2</sub> regulator

## Wiring Diagram – Concessionaire Dispensers

DC Series 2, 3 and 4 Keg Concessionaire Portable Dispensers

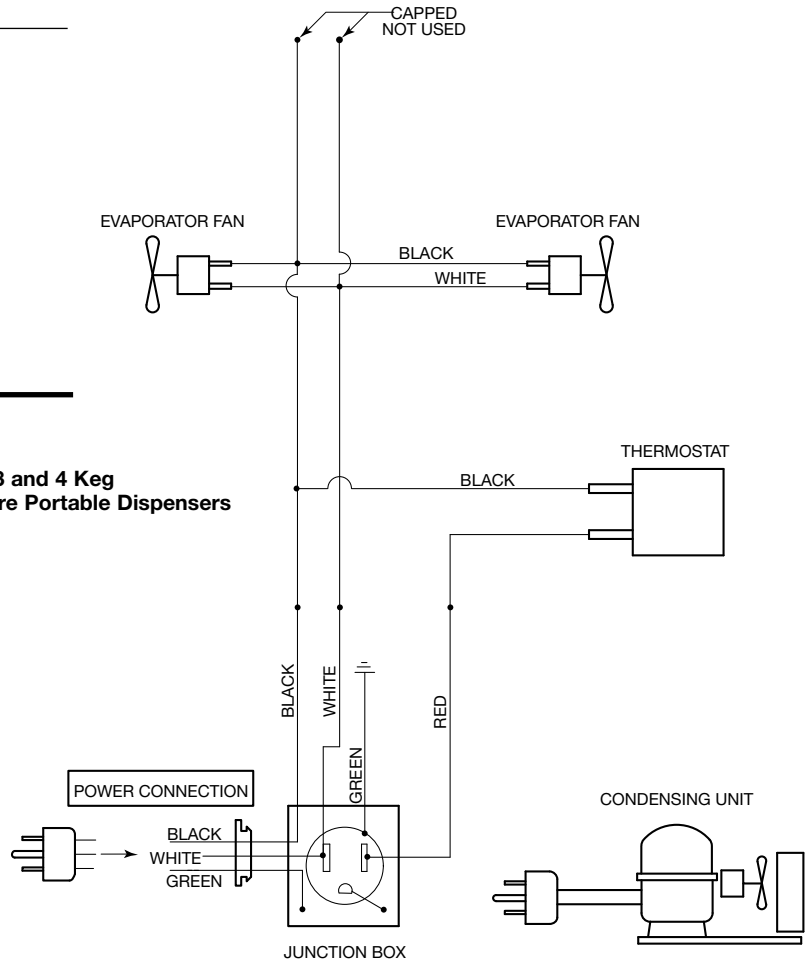

# Reversing Door Hinge

## Tools Required

- #3 Phillips Screwdriver.
- 1/16" Allen Wrench.
- Flathead Screwdriver

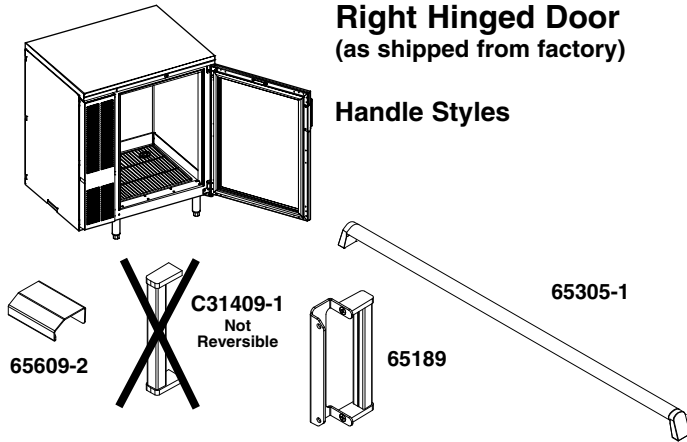

## Operations to Perform on Cabinet

**STEP 1:**  
Remove bottom hinge pin from assembly.

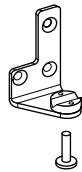

**STEP 2:**  
Carefully lift and tilt out door assembly from the unit and set aside.

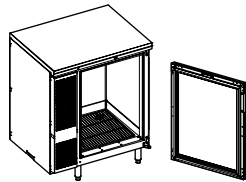

**STEP 3:**  
Remove lock rail from cabinet, requires removal of four screws.

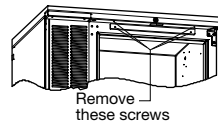

**STEP 4:**  
Remove top hinge pin. Remove top and bottom hinge brackets from the unit.

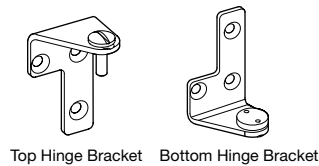

**STEP 5:**  
Remove hinge bushing from bottom hinge bracket and assemble to top hinge bracket.



**STEP 6:**  
Taking care not to scratch the surface, remove hole plugs from the left hinge holes.

**STEP 7:**  
Insert hole plugs into vacant right hinge holes.

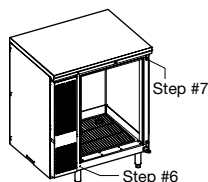

**STEP 8:**  
Re-assemble hinge brackets to unit. Bottom right bracket is assembled as the top left bracket. Top right bracket is assembled as the bottom left bracket.

**STEP 9:**  
Re-insert top hinge pin.

**STEP 10:**  
Re-assemble lock rail from STEP #3

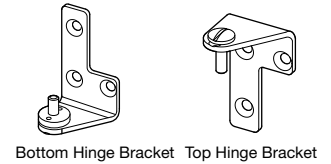

## Operations to Perform on Door

**STEP 11:**  
Remove bottom door hinge bracket from door assembly and remove door hinge bushing from bracket. Re-assemble door hinge bracket to previous position, without bushing.

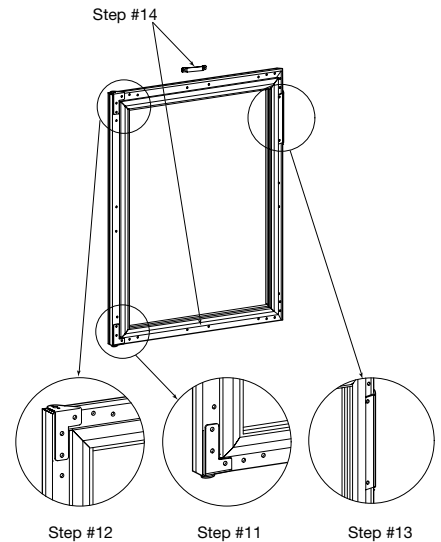

**STEP 12:**  
Remove top door hinge bracket from door assembly and assemble door hinge bushing from STEP 11 to bracket. Re-assemble door hinge bracket to previous position with bushing attached.

**STEP 13:**  
**Door with full length SS handle:**  
There is no need to remove door handle. It will be positioned correctly when door is reversed.

**Door with SS pull tab or handle with wrap-around bracket:**  
Remove the two screws mounting the handle and reposition to appropriate location on the opposite side of the door.

**STEP 14:**  
Remove lock retainer and install on opposite end of door.

**STEP 15:**  
What was the door top is now the door bottom. Carefully lift the door onto the hinge brackets of the cabinet. The two hinge bushings should meet. Reinsert the bottom hinge pin to complete the door switching operation.



8300 West Good Hope Road • Milwaukee, WI 53223 • Phone 414-353-7060 • Fax 414-353-7069  
Toll Free 800-558-5592 • E-Mail: Perlick@Perlick.com • www.Perlick.com