

INSTALLATION AND OPERATION INSTRUCTIONS

CUSTOM NARROW DOOR BACK BAR CABINETS – SELF CONTAINED AND REMOTE



MODELS

NR Series

NS Series

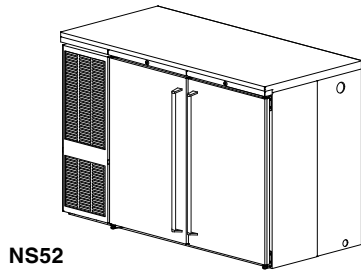

NS52

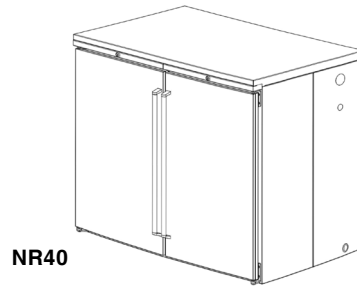

NR40

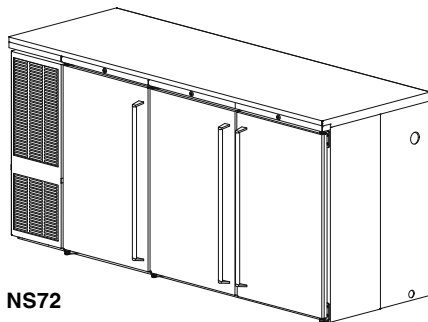

NS72

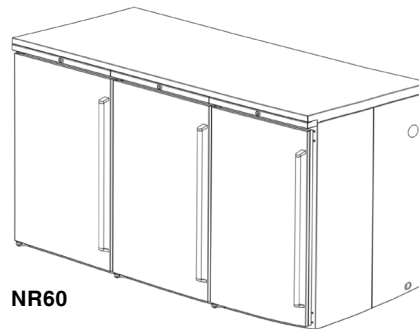

NR60

IMPORTANT INFORMATION

To register your product, visit our web site at (www.perlick.com). Click on “Commercial”, then “Service”. You will see the link to “Warranty Registration Form”. You must complete and submit this form or the installation date will revert back to the ship date.

This manual has been prepared to assist you in the installation of your cabinet and to acquaint you with its operation and maintenance.

We dedicate considerable time to ensure that our products provide the highest level of customer satisfaction. If service is required, your dealer can provide you with a list of qualified service agents. For your own protection, never return merchandise for credit without our approval.

We thank you for selecting a Perlick product and assure you of our continuing interest in your satisfaction.

WARNING: When lifting, the full weight of the cabinet must be supported. Lift from the cabinet base and not from the top. Improper lifting can result in severe damage to the cabinet.

Table of Contents

PREPARING THE CABINET

List of Included Parts	2
Tools Required.....	2
Plumbing.....	2
Electrical.....	2
Uncrating and Inspection	2
Placing the Cabinet.....	2
Leveling the Cabinet.....	2
Installing Casters or Legs	2
Installing the Base Plates.....	2
Refrigeration and Temperature Control.....	3
Cleaning the Cabinet.....	3
Cleaning the Condenser.....	3
Stainless Steel Care Guide.....	4/5
Replacement Parts.....	6
Reversing Door Swing.....	7
Wiring Diagram (NS Series)	8
Wiring Diagram (NR Series)	9

Form No. Z2285
Rev. 10.05.10



8300 West Good Hope Road • Milwaukee, WI 53223 • Phone 414.353.7060 • Fax 414.353.7069
Toll Free 800.558.5592 • E-Mail perlick@perlick.com • www.perlick.com

SYSTEMS AND PRODUCTS FOR THE FOOD SERVICE AND BEVERAGE INDUSTRIES SINCE 1917

GENERAL INFORMATION – Narrow Door Back Bar Cabinets

Parts List

- (3) Shelves per door (one may be used as a floor rack)
- Door lock keys
- Shelf clips

Tools Required

- #2 Phillips Screwdriver
- 3/8" Nut Driver
- Power Drill or Driver (for leg or caster installation)

Plumbing

Condensate from the cooling coil is automatically evaporated from the condensate pan located in the condensing unit housing. Each unit is also equipped with a floor drain located in the right rear corner of the cabinet. The drain can be plumbed to an external floor drain by connecting to the 3/4" NPT thread out the side or the 1" NPS thread out the bottom. Both drains ports come plugged from the factory and can be removed if needed.

NOTE: Remote units require evaporator condensate to be plumbed to an external drain.

Electrical

The cabinet must be connected to a separately fused power source (see electrical specification plate) and grounded in accordance with National and Local Electrical Codes. Caution: Do not attempt to operate the equipment on any other power source than that listed on the Electrical Specification plate.

Uncrating and Inspection

Remove all crating material before operating. Carefully inspect cabinet for hidden damage. If damage is discovered, file your claim immediately with the transportation company. Perlick is not responsible for damage in transit.

Placing the Cabinet

Push the cabinet into place using rollers when necessary. **IMPORTANT:** Proper air flow around the condensing unit is necessary for efficient operation. Never obstruct the air flow in and out of the condensing unit.

For sanitation purposes, it may be necessary to seal the base of the cabinet to the floor. This can be accomplished by laying a bead of silicone sealant between the base of the cabinet and the floor as shown by the figure below:

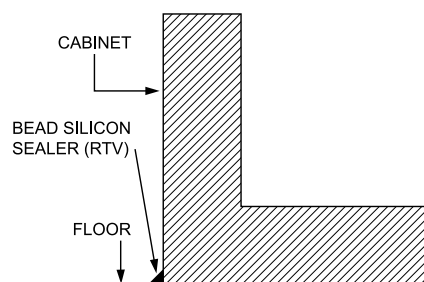

Leveling the Cabinet

When the cabinet is in place, check installation with carpenter's level. When level front to back and left to right, accumulated water will drain out of the cabinet.

Installing Casters or Legs (optional)

Attach casters or legs to cabinet bottom in holes provided. Use the supplied 1/4"-20 x 3/4" hex head self-tapping machine screws.

Installing Base Plates (optional)

Attach brackets to cabinet bottom in holes provided. Attach base plate to brackets (see separate instructions, provided with kit). When returning cabinet to upright position, be careful not to bend brackets.

WARNING! To avoid compressor damage, after running cabinet in an upright position, let unit stand for 24 hours before plugging in and running the unit.



Perlick is committed to continuous improvement. Therefore, we reserve the right to change specifications without prior notice

GENERAL INFORMATION – Narrow Door Back Bar Cabinets

Refrigeration and Temperature Control

Self-contained units are equipped with a heavy-duty refrigeration system that is factory set to maintain a product storage temperature of approximately 38° F.

Adjusting the Temperature

The temperature control is inside the cabinet on the left-hand side of the evaporator fan panel assembly. You will need a screwdriver to turn the adjusting screw. Make small adjustments until the desired temperature is achieved.

Colder Temperatures:

Turn the adjusting screw clockwise (to the right)

Warmer Temperatures:

Turn the adjusting screw counterclockwise (to the left).

Temperature Control 'OFF':

Turn the adjusting screw completely counterclockwise to the 'O' position until a click is noted.

The condenser fan motor turns off and on with the compressor. The evaporator fan motor is on all the time.

CAUTION: *Cabinet temperatures lower than 34° F will not allow for proper defrosting of the evaporator coil. If defrosting is necessary, turn the control knob to the OFF position until coil is defrosted.*

Cleaning the Cabinet

Use a mild detergent and water to clean the inside and outside of the cabinet. Dry thoroughly. Never use a scouring pad or abrasive cleanser. See the Stainless Steel care guide on pages 4 and 5 for more information on proper care of stainless steel.

NOTE: *An industrial strength, commercial cleaner can be used to clean the outside of painted cabinets.*

Cleaning the Condenser

The condenser (located behind the front grille cover) should be inspected every 30 days and cleaned, if necessary. Use a long handled, stiff brush or vacuum to clean the dirt from the front surface of the condenser. Keeping the condenser free from dust and dirt will ensure efficient operation.

CAUTION: *Do not bend the fins while brushing the front of the condenser.*

Failure to keep the condenser clean will cause a loss in condensing unit efficiency.

Specifications

For complete specifications, please visit our website at www.perlick.com.

STAINLESS STEEL

CARE AND CLEANING REFERENCE GUIDE

Contrary to popular belief, stainless steels ARE susceptible to rusting. Corrosion on metals is everywhere. It is recognized quickly on iron and steel as unsightly yellow/orange rust. Such metals are called “active” because they actively corrode in a natural environment when their atoms combine with oxygen.

Stainless steels are “passive” metals because they contain other metals like chromium, nickel and manganese that stabilize the atoms. Chromium provides an invisible passive film that covers the steels surface acting as a shield against corrosion. As long as the film is intact and not contaminated, the metal is passive and stainless. If the passive film of stainless steel has been broken, equipment starts to corrode. At its end, it rusts.



ENEMIES OF STAINLESS STEEL

There are three basic things which can break down stainless steel's passive layer and allow corrosion to occur:

1. Mechanical abrasion
2. Deposits and water
3. Chlorides

Mechanical Abrasion refers to the things that will scratch a steel surface. Steel pads, wire brushes and scrapers are prime examples.

Water comes out of the faucet in varying degrees of hardness. Depending on what part of the country you live in, you may have hard or soft water. Hard water may leave spots. When allowed to sit, these deposits will break down the passive layer and rust stainless steel. Other deposits from food preparation must be promptly removed with an appropriate cleaning agent.

Chlorides are found nearly everywhere. They are in water, food and table salt. Household and industrial cleaners are the worst offenders.

PREVENTING STAINLESS STEEL RUST

Use the proper tools Use non-abrasive tools to clean stainless steel products. Soft cloths and plastic scouring pads will not harm the steel's passive layer.

Clean with polish lines Some stainless steels comes with visible polishing lines or “grain”. When visible lines are present, always scrub in a motion parallel to the lines. When the grain cannot be seen, play it safe and do not use a circular motion. Polish in a consistent straight pattern.

Use alkaline, alkaline chlorinated or non-chloride containing cleaners While many traditional cleaners are loaded with chlorides, the industry is providing an ever-increasing choice on non-chloride cleaners. If you are not sure of chloride content in the cleaner being used, contact your cleaner supplier. If your present cleaner contains chlorides, ask your supplier if they have an alternative. Avoid cleaners containing quaternary salt; it also can attack stainless steel and cause pitting and rusting.

Keep your food equipment clean Use alkaline, alkaline chlorinated or non-chloride cleaners at recommended strength. Clean frequently to avoid build-up of hard, stubborn stains. The single most likely cause of damage is chlorides in the water. Remember, adding heat to cleaners that contain chlorides dramatically increases their caustic effect on stainless steel.

Rinse, rinse, rinse! If chlorinated cleaners are used, immediately rinse and wipe equipment and supplies dry. The sooner you wipe off standing water, especially when it contains cleaning agents, the better. After wiping equipment down, allow it to air dry; oxygen helps maintain the stainless steel's passive film.

NEVER use hydrochloric acid (muriatic acid) on stainless steel!



Perlick is committed to continuous improvement. Therefore, we reserve the right to change specifications without prior notice

RECOMMENDED CLEANERS FOR SPECIFIC SITUATIONS

Routine cleaning: Use soap, ammonia or detergent and water. Sponge the surface with a cloth, then rinse with clear water and wipe dry.

Smears and fingerprints: Use Signature Cleaning Polish, Arcal 20, Lac-O-Nu, Lumin Wash, O'Cedar Cream Polish or Stainless Shine. Rub the surface with a cloth as directed on the package.

Stubborn spots, stains and other light discolorations: Use Allchem Concentrated Cleaner Samae, Twinkle, Cameo Copper Cleaners, Grade FFF Italian Pumice Whiting, Steel Bright, Lumin Cleaner, Zud, Restoro, Sta-Clean, Highlite Cooper's Stainless Steel Cleaner or Revere Stainless Steel Cleaner. Apply with a damp sponge or cloth. Then rinse with clear water and wipe dry. Or... You can also use Household cleansers such as Old Dutch, Lighthouse, Sunbrite, Wyandotte, Bab-O, Gold Dust, Sapolio, Bon Ami or Comet. For these household cleansers, rub with a damp cloth. They may contain chlorine bleaches, so rinse thoroughly after use and wipe dry. Or... You can also use Liquid NuSteel or Dubois Temp. For these products, rub the surface with a dry cloth using only a small amount of cleanser. Rinse with water and dry.



Heat tint or heavy discoloration: Use Penny-Brite, Copper Brite, Paste Nu-Steel, Dubois Temp or Tarnite and rub onto surface with a dry cloth. Or... You can also use Bar Keepers Friend, Revere Stainless Steel Cleaner, Allen Polish, Steel Bright, Wyandotte, Bab-O or Zud. For these cleansers, apply with a damp sponge or cloth, rinse thoroughly and wipe dry.

Tenacious deposits, rust discoloration, industrial atmospheric stains: Use Oakite No. 33 Dilac, Texo NY, Flash-Klenz, Caddy Cleaner, Turco Scale 4368 or Permag 57. Swab and soak with a clean cloth. Let stand for 15 minutes or more according to directions on package. Then rinse and wipe dry.

Rust discoloration or corrosion caused by cleaning agents containing hydrochloric (muriatic) acid or chlorine bleach: Use 3M Scotch Bright Pad, type A Grade "Fine". Clean off the surface soil using cleaning methods above. Then rub discolored or corroded areas lightly with dry pad.

Note: Use of proprietary names is intended to indicate a type of cleaner and does not constitute an endorsement. Omission of any proprietary cleaner does not imply its inadequacy. All products should be used in strict accordance with instructions on the package.

Source: Packer Engineering, Naperville, IL (independent testing laboratory).

REMEMBER...

Use **non-chlorinated cleaners** with a **soft cloth** and **RINSE, RINSE, RINSE** to maintain the natural qualities of your stainless steel equipment!

GENERAL INFORMATION – Narrow Door Back Bar Cabinets

MODELS	NS52	NR40	NS72	NR60
Condensing unit 115 volt, 60 hz.	C22647	N/A	C22646	N/A
Condensing Unit	515301063	N/A	515301062	N/A
Compressor	513200314	N/A	513200003	N/A
Condensor Fan Motor Assembly	515315009	N/A	515315009	N/A
Condenser Coil	15352019	N/A	15352019	N/A
Terminal Board	519100088	N/A	519100088	N/A
Overload Protector	US-PB10HBX1	N/A	US-PB12HBX1	N/A
Relay	US-PB10HBX1	N/A	US-PB12HBX1	N/A
Capacitor	US-PB10HBX1	N/A	US-PB12HBX1	N/A
Evaporator Coil	C17511-1EP	C17511-1EP	C17511-2EP	C17511-2EP
Evaporator Coil Assembly	65644-1	69197-1,(2),(3)	65644-2	65627-1,(2),(3)
Liquid & Suction Line	65084	N/A	65085	N/A
Fan Blade	57699	57699	57699	57699
Evaporator Fan Motor	C15239A	C15239A	C15239A	C15239A
Evaporator Fan Guard	65557	65557	65557	65557
Temperature Control	61283	N/A	61283	N/A
Bulb Clamp	C6634	N/A	C6634	N/A
Wire Harness, Compressor Bottom	65560	N/A	65560	N/A
Wire Harness, Evaporator	65561	65561	65561	65561
Wire Harness, Light jumper	65538	65538	65539	65539
Wire Harness, Mullion Heater	65571	65571	65572	65572
Light Bulb	63821	63821	63821	63821
Light Bulb Guard	65525	65525	65525	65525
Light Socket	63484	63484	63484	63484
Light Switch	65535	65535	65535	65535
Lock	63762	63762	63762	63762
Spacer, Lock	63761-1	63761-1	63761-1	63761-1
Lock Rail	65432-20SS or 65432-20	65432-20SS or 65432-20	65432-20SS or 65432-20	65432-20SS or 65432-20
Grille Rail	65432-12SS or 65432-12	N/A	65432-12SS or 65432-12	N/A
Condensate Pan	65565-1	N/A	65565-1	N/A
Condensing Housing End Panel	66215-1SS	N/A	66215-1SS	N/A
Grille	RG-NL2	N/A	RG-NL2	N/A
Condenser Housing Back	65435-12SS	N/A	65435-12SS	N/A
Evaporator, Liquid & Suction Line Cover	65606L-1 or 65606R-1	65606L-1	65576-4L	65576-4L
Evaporator Pan	66311-1	66311-1	65526-2	65526-2
Door Handle	<i>Several Options - Contact Factory</i>			
Door Gasket	66237-5	66237-5	66237-5	66237-5
Cabinet Hinge Group Left	66264L	66264L	66264L	66264L
Cabinet Hinge Group Right	66264R	66264R	66264R	66264R
Hinge Pin	63679-1	63679-1	63679-1	63679-1
Left or Right End Shelf - Flat	66355	66355	66355	66355
Center Shelf - Flat	N/A	N/A	66356	66356
Left or Right End Shelf - Divided	66398-1	66398-1	66398-1	66398-1
Center Shelf - Divided	N/A	N/A	66399-1	66399-1
Plaster Strip	C19271-1	C19271-1	C19271-1	C19271-1
Shelf Clips (bag of 12)	63019-3	63019-3	63019-3	63019-3
*Replacement Door	RND-NL2	RND-NL2	RND-NL2	RND-NL2

*Contact Perlick Milwaukee for complete door replacement. Cabinet serial no. required.



Perlick is committed to continuous improvement. Therefore, we reserve the right to change specifications without prior notice

REVERSING DOOR HINGE – Narrow Door Back Bar Cabinets

Tools Required

- #3 Phillips Screwdriver.
- 1/16" Allen Wrench.
- Flathead Screwdriver

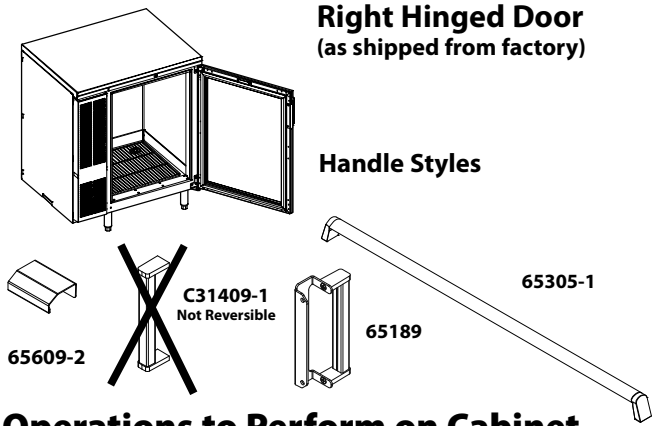

Operations to Perform on Cabinet

STEP 1:

Remove bottom hinge pin from assembly.

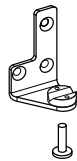

STEP 2:

Carefully lift and tilt out door assembly from the unit and set aside.

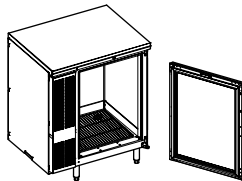

STEP 3:

Remove lock rail from cabinet, requires removal of four screws.

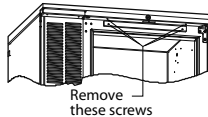

STEP 4:

Remove top hinge pin. Remove top and bottom hinge brackets from the unit.

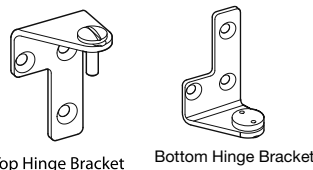

STEP 5:

Remove hinge bushing from bottom hinge bracket and assemble to top hinge bracket.



STEP 6:

Taking care not to scratch the surface, remove hole plugs from the left hinge holes.

STEP 7:

Insert hole plugs into vacant right hinge holes.

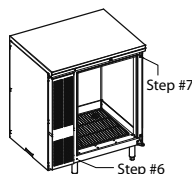

STEP 8:

Re-assemble hinge brackets to unit. Bottom right bracket is assembled as the top left bracket. Top right bracket is assembled as the bottom left bracket.

STEP 9:

Re-insert top hinge pin.

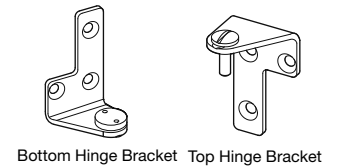

STEP 10:

Re-assemble lock rail from STEP #3

Operations to Perform on Door

STEP 11:

Remove bottom door hinge bracket from door assembly and remove door hinge bushing from bracket. Re-assemble door hinge bracket to previous position, without bushing.

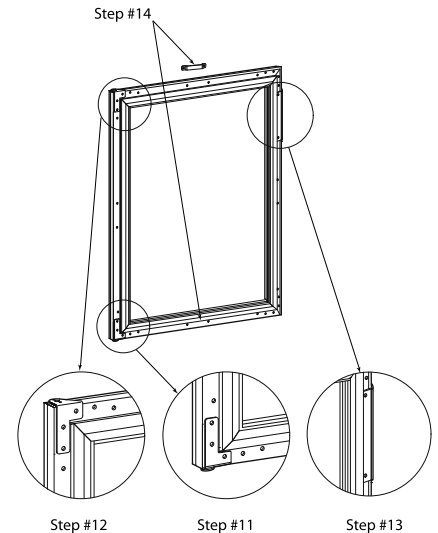

STEP 12:

Remove top door hinge bracket from door assembly and assemble door hinge bushing from STEP 11 to bracket. Re-assemble door hinge bracket to previous position with bushing attached.

STEP 13:

Door with full length SS handle:

There is no need to remove door handle. It will be positioned correctly when door is reversed.

Door with SS pull tab or handle with wrap-around bracket:

Remove the two screws mounting the handle and reposition to appropriate location on the opposite side of the door.

STEP 14:

Remove lock retainer and install on opposite end of door.

STEP 15:

What was the door top is now the door bottom. Carefully lift the door onto the hinge brackets of the cabinet. The two hinge bushings should meet. Reinsert the bottom hinge pin to complete the door switching operation.

WIRING DIAGRAM – NS Series Cabinets

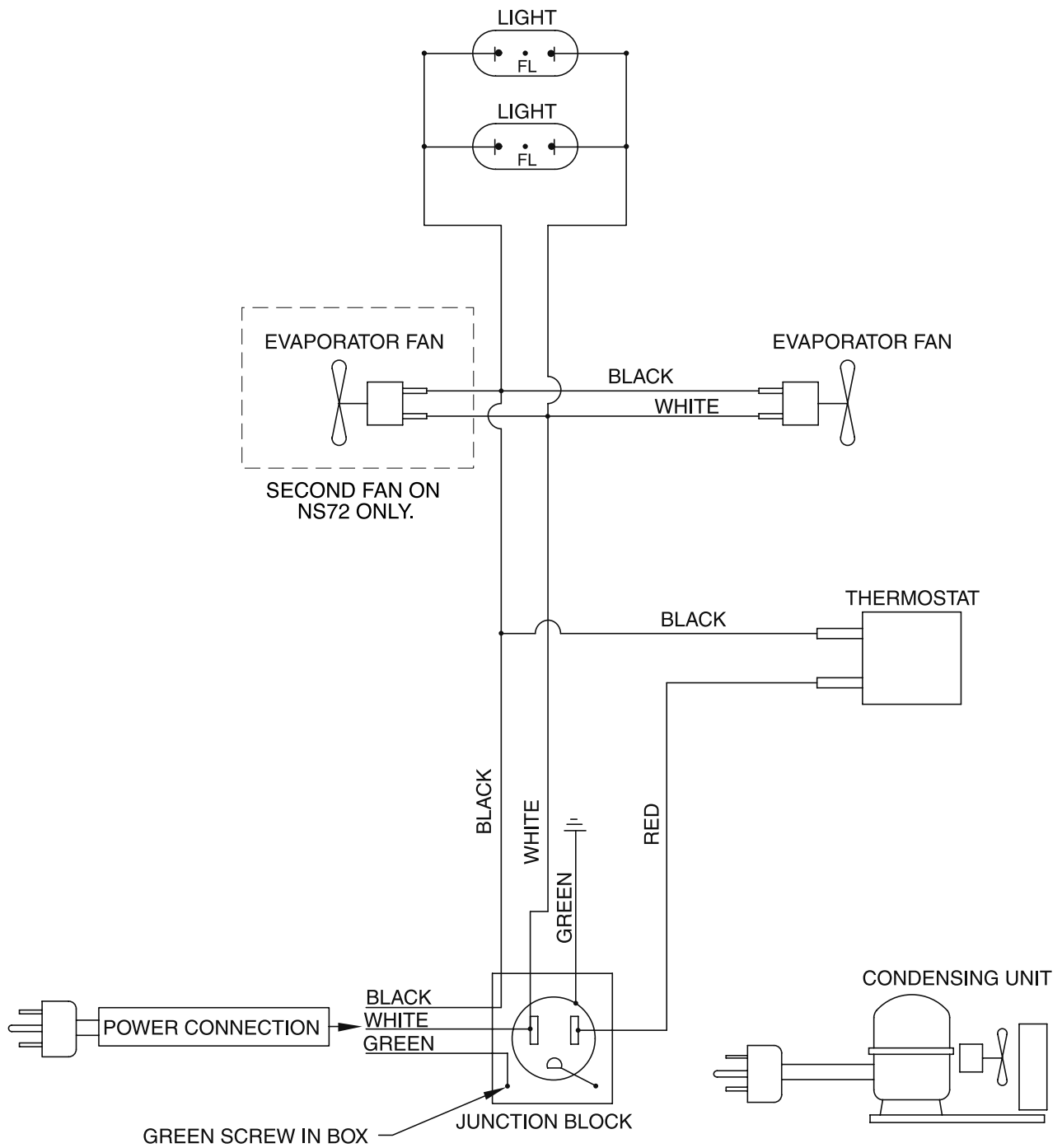

Perlick is committed to continuous improvement. Therefore, we reserve the right to change specifications without prior notice

WIRING DIAGRAM – NR Series Cabinets

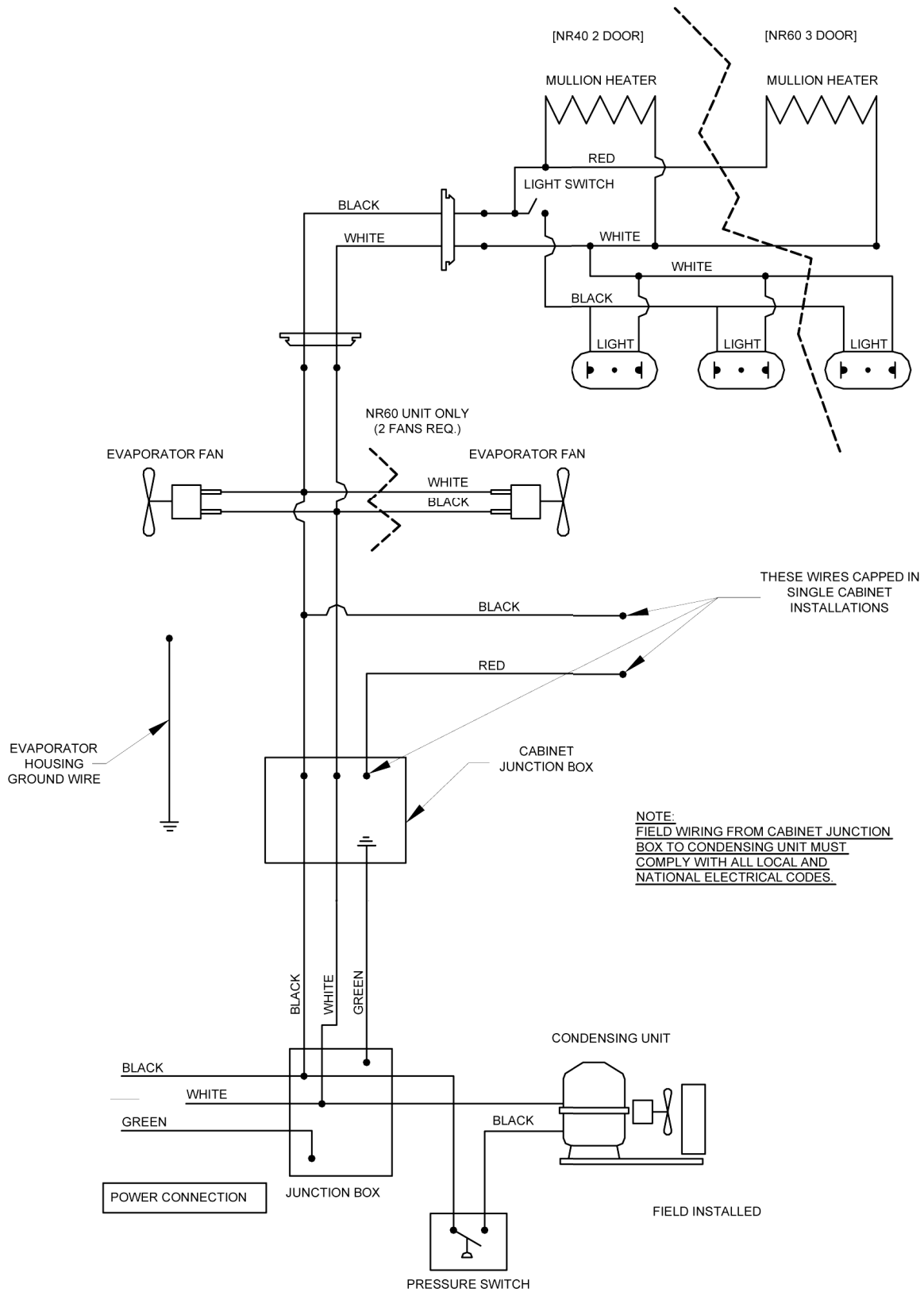

Perlick is committed to continuous improvement. Therefore, we reserve the right to change specifications without prior notice



Notes...



Perlick is committed to continuous improvement. Therefore, we reserve the right to change specifications without prior notice

Notes...

Perlick is committed to continuous improvement. Therefore, we reserve the right to change specifications without prior notice





8300 WEST GOOD HOPE ROAD
MILWAUKEE, WISCONSIN 53223

WWW.PERLICK.COM • 800.558.5592

SYSTEMS AND PRODUCTS FOR THE FOODSERVICE AND BREWING INDUSTRIES SINCE 1917