

# Pitco Fryalator

Installation, Operation, and Maintenance  
Manual  
For Electric Fryers With Options  
Including Built-In and UFM (Spacefighter)  
Filter Systems  
Covering Models  
E7, E7B, E14, E14B, E14X, E18, & E18B

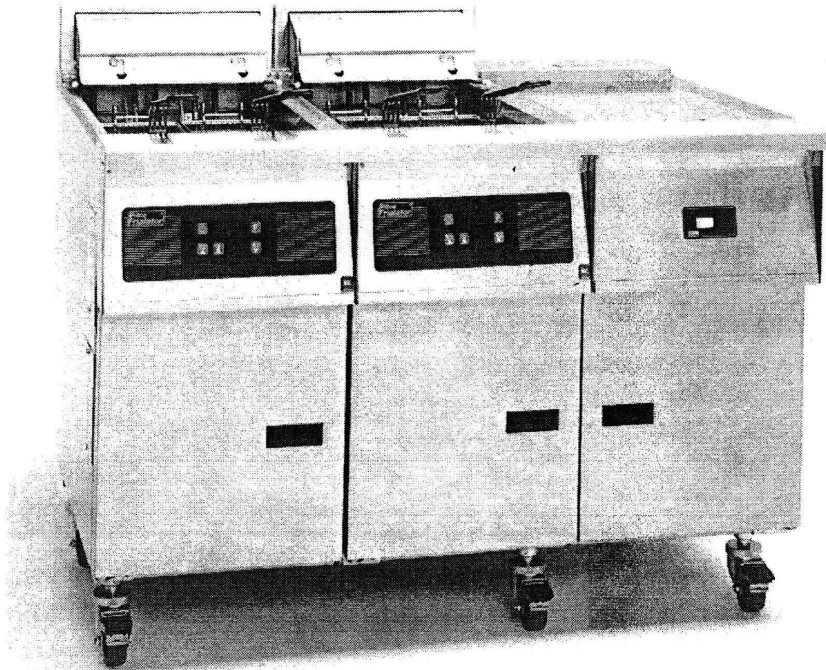

*There's Always Something Cooking!*

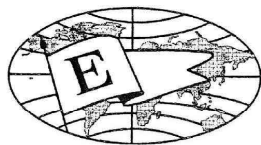



## NOTICES

There are three different types of notices that you should be familiar with, a NOTICE, CAUTION, and WARNING. A NOTICE is a special note used to call attention to a particularly important point. CAUTION is used to point out a procedure or operation which may cause equipment damage. The WARNING notice is the most important of the three because it warns of an operation that may cause personal injury. Please familiarize yourself with your new cooker before operating it and heed the notices throughout this manual. The WARNINGS are listed below and on the following page for your review prior to operating the unit.

### **FOR YOUR SAFETY**

**DO NOT store or use gasoline or other flammable vapors or liquids in the vicinity of this or any other appliance.**

**WARNING: Improper installation, adjustment, alteration, service or maintenance can cause property damage, injury or death. Read the installation, operating and maintenance thoroughly before installing or servicing this equipment.**

**THIS MANUAL MUST BE RETAINED FOR FUTURE REFERENCE**

**SAFETY**

**SAFETY**

**SAFETY**

**SAFETY**

**SAFETY**

**WARNING**

The fryer must be electrically grounded in accordance with local codes. If local codes do not apply follow the requirements of National Code ANSI/NFPA 70-1990

**WARNING**

Before proceeding with installation, ensure that the switch(s) marked OFF-ON-START are in the OFF position. Also ensure that all the circuit breakers for the appliance(s) are OPEN or OFF. NEVER connect the fryer with power applied to the power lines. Some appliances have more than one power supply. Make sure they are ALL disconnected.

**WARNING**

The heating elements MUST be covered with water or oil before they are turned on. NEVER turn on the fryer unless the elements are covered by at least one inch of liquid.

**WARNING**

Never melt blocks of shortening on top of the heating elements. This will cause a fire, and void your warranty.

**WARNING**

Water and shortening DO NOT mix. Keep liquids away from hot shortening. Dropping liquid frozen food into the hot shortening will cause violent boiling.

**WARNING**

At operating temperature the shortening temperature will be greater than 300°F. Extreme care should be used when filtering operating temperature shortening to avoid personnel injury.

**WARNING**

It will be easier and safer if the filter assembly has cooled to room temperature before handling any filter parts.

**WARNING**

All power supplies must be disconnected before servicing or cleaning the appliance. Some appliances have more than one power supply. Make sure they are ALL disconnected.

**SAFETY**

**SAFETY**

**SAFETY**

**SAFETY**

**SAFETY**

**SAFETY**

**SAFETY**

**SAFETY**

**SAFETY**

**SAFETY**

**WARNING**

**DANGER - HIGH VOLTAGE PRESENT**

The fuses for the fryer's heating elements and controls are located inside the entrance box. Extreme care must be taken when opening the entrance box. **NEVER** remove the entrance box cover unless all power to the appliance has been disconnected.

**SAFETY**

**SAFETY**

**SAFETY**

**SAFETY**

**SAFETY**

# Table of Contents

Section	Title	Page
Safety Notice		
	Table of Contents .....	i-iii
	List of Tables and Figures .....	iv
<b>Chapter 1: General Information and Installation .....</b>		<b>1-1</b>
1.1	WHICH FRYER DO I HAVE? .....	1-1
1.2	CHECKING YOUR NEW FRYER .....	1-2
1.2.1	Check Your Order .....	1-2
1.3	ASSEMBLY AND LEVELING .....	1-3
1.3.1	Leg/Caster Installation and Adjustment .....	1-3
1.3.2	Assembling multi fryer .....	1-3
1.3.3	Basket Lift Access .....	1-4
1.4	INSTALLATION .....	1-4
1.4.1	Installation Clearances .....	1-4
1.4.2	CO <sub>2</sub> Fire System .....	1-4
1.4.3	Electrical Connection .....	1-5
1.4.4	Ventilation and Fire Safety Systems .....	1-8
1.5	INITIAL ADJUSTMENTS .....	1-9
1.5.1	Visual Checks .....	1-9
1.5.2	Initial Cleaning .....	1-10
1.5.3	Thermostat Calibration Check - Backup Thermostat Only .....	1-11
<b>Chapter 2: Operating Instructions .....</b>		<b>2-1</b>
2.1	FILLING THE FRYER .....	2-1
2.1.1	Filling the Fryer With Liquid Shortening .....	2-1
2.1.2	Filling the Fryer With Solid Shortening .....	2-1
2.2	OPERATING INSTRUCTIONS - WITHOUT COMPUTER .....	2-2
2.2.1	Fryer Start-Up .....	2-2
2.2.2	Automatic Basket Lifts (Optional) .....	2-3
2.2.3	Fryer Shutdown .....	2-3
2.3	OPERATING INSTRUCTIONS - WITH A COMPUTER .....	2-4
2.3.1	Fryer Start-Up .....	2-4
2.3.2	Product Selection .....	2-4
2.3.3	Shutdown .....	2-4
2.3.4	Power Failure .....	2-4
2.4	THE INTELLIFRY COMPUTER .....	2-5
2.4.1	Checking the Temperature functions and Cooking Times .....	2-6
2.4.2	Programming Cook Time, Shake Time and Hold Times .....	2-6

## Table of Contents (Continued)

<b>Section</b>	<b>Title</b>	<b>Page</b>
2.4.3	Programming Cooking Temperature .....	2-7
2.4.4	Level 2 Programming .....	2-7
2.5	THE DIGITAL CONTROL .....	2-8
2.5.1	Operating the Digital control .....	2-8
2.5.2	Programming the Digital control .....	2-9
2.6	SHORTENING FILTER PROCEDURES .....	2-10
2.6.1	General Filter Hints .....	2-12
2.6.2	Filter Procedures .....	2-13
2.6.3	Using The UFM Module as a Portable Filter .....	2-15
2.7	DAILY CLEANING .....	2-16
<b>CHAPTER 3: Owner Maintenance and Adjustments .....</b>		<b>3-1</b>
3.1	FILTER MEDIA REPLACEMENT .....	3-1
3.1.1	UFM Filter System .....	3-1
3.1.2	Built-In Filter System .....	3-4
3.2	WEEKLY FRYER CLEANING (BOIL OUT) .....	3-8
3.3	INSTALLING THE OPTIONAL FLUSH HOSE .....	3-9
3.4	BASKET LIFT LUBRICATION .....	3-9
3.5	CHECKING AND REPLACING FUSES .....	3-9
3.6	TROUBLESHOOTING .....	3-11
3.6.1	Fryer Troubleshooting - Without a Computer .....	3-11
3.6.2	Fryer Troubleshooting - With a Computer .....	3-16
3.6.3	Built-In Filter Troubleshooting .....	3-18
3.6.4	UFM Filter Troubleshooting .....	3-20

# List of Tables and Figures

<b>Table</b>	<b>Title</b>	<b>Page</b>
1-1	Fryer Model Information .....	1-1
1-2	Electrical Requirements for Various Models .....	1-6
1-3	Ventilation and Fire Safety References .....	1-8

<b>Figure</b>	<b>Title</b>	<b>Page</b>
1-1	Filter Tools and Accessories .....	1-2
1-2	Inside View of Fryer Tank .....	1-9
1-3	Pilot Assembly, Flame Adjustment .....	1-11
1-4	Gas Valve Showing Location of Pressure Regulator and Pilot Adjusters .....	1-12
1-5	Main Burner Conditions .....	1-14
1-6	Air Collar .....	1-15
2-1	Fryer Illustrating Filter Components .....	2-10
2-2	Filter Tools and Accessories .....	2-11
3-1	UFM Filter Module .....	3-2
3-2	Built-In Filter System .....	3-6
3-3	Fryer Showing Built-In Filter System Components .....	3-7



# Chapter 1: General Information and Installation

Congratulations on the purchase of your new Pitco Frialator universal electric fryer. This unit will give you many years of reliable service if you follow the simple operation and maintenance procedures in this manual. Contained in this manual are the general installation, operation, and maintenance procedures for the universal electric fryer models E7, E7B, E14, E14B, E14X, E18, & E18B. This information covers both the units with built-in filters and the Under Fryer Manual (UFM) filters.

## 1.1 WHICH FRYER DO I HAVE?

All models come standard with solid state temperatures controls, automatic melt cycle controller, and built in safety devices. In addition to these features additional features and options are available, each with its own model number. To find out which model you have look at the identification plate inside the door. This plate has a lot of useful information, but to identify which fryer you have, look at the model number block. The model number identifies which fryer and what features you have. A brief description of each model and its features are provided in Table 1-1.

Table 1-1 Fryer Model Information

Model Number	Description	Features
E7 E7B	Model 7 is a great space saver. The E7 model can cook up to 40 lbs. of potatoes per hour and the E7B model can produce up to 45 lbs. per hour.	Frying Area: 8" X 14" Oil Capacity: 25 Lbs Input Ratings: E7 - 7.0 KW E7B - 9.0 KW
E14 E14B E14X	All purpose fryer designed to fry a wide range of products. These fryers can produce large quantities of potatoes: E14 - up to 75 lbs per hour; E14B - up to 102 lbs per hour; and the E14X up to 60 lbs per hour.	Frying Area: 14" X 14" Oil Capacity: 40 Lbs Input Rating: E14 - 16.5 KW E14B - 21.0 KW E14X - 13.5 KW
E18 E18B	This model is designed for the most demanding frying needs. Available with many options and features to meet any cooking need. The E18 model can produce up to 120 lbs. of potatoes per hour and the E18B model can produce up to 94 lbs. of chicken per hour.	Frying Area: 18" X 18" Oil Capacity: E18 - 65 Lbs. E18B - 100 Lbs. Input Rating: E18 - 18.0 KW E18B - 24.0 KW

## 1.2 CHECKING YOUR NEW FRYER

Your new fryer and its filter have been carefully packed in two crates. Every effort has been made to ensure that your fryer will be delivered to you in perfect condition. As you unpack the fryer, inspect each of the pieces for damage. If something is damaged, **DO NOT** sign the bill of lading. Contact the shipper immediately, because the shipper is only responsible for 15 days after delivery. Check the packing list enclosed with your fryer to ensure that you have received all of the parts to the fryer. If you are missing any parts, contact the dealer from whom the fryer was purchased. As you unpack the fryer and its accessories be careful to keep the weight of the fryer evenly distributed.

### Element Junction Box

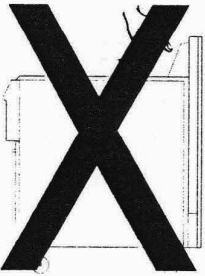

### CAUTION

To prevent equipment damage, don't tilt the fryer onto any two of its casters or pull the unit by the element junction box.

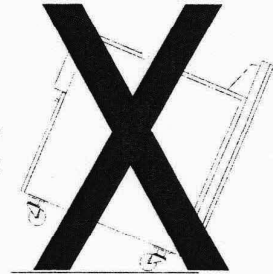

Locate your Pitco Frialator warranty and fill in the serial number of the fryer and the date received. You will find the serial number on the plate inside the door. Put your warranty card in a safe place for future reference. **DO NOT** return the card to Pitco Frialator.

### 1.2.1 Check Your Order

The crate containing the fryer unit will also contain the following:

- (2) Fry baskets per fryer
- (1) Fry Basket Hanger per fryer
- (2) Pitco Cleaner Sample {5}
- (1) Drain Clean Out Rod {4}

The crate with the filter module (if applicable) also contains the filter tools and accessories shown in Figure 1-1. These items are very important and **MUST** be retained for future use. A complete description of each component is contained in the Shortening Filter Procedure in Chapter 2.

- (1) Filter Crumb Catch {3}
- (1) Precoat Filter Aid {7}
- (1) Flush Hose (Optional) {1}
- (25) Filter Sheets {2}
- (1) Cleaning Brush (Fryer) {8}
- (1) Fryer Crumb Scoop {10}
- (1) Filter Crumb Scoop {6}
- (1) Precoat Measuring Cup {9}

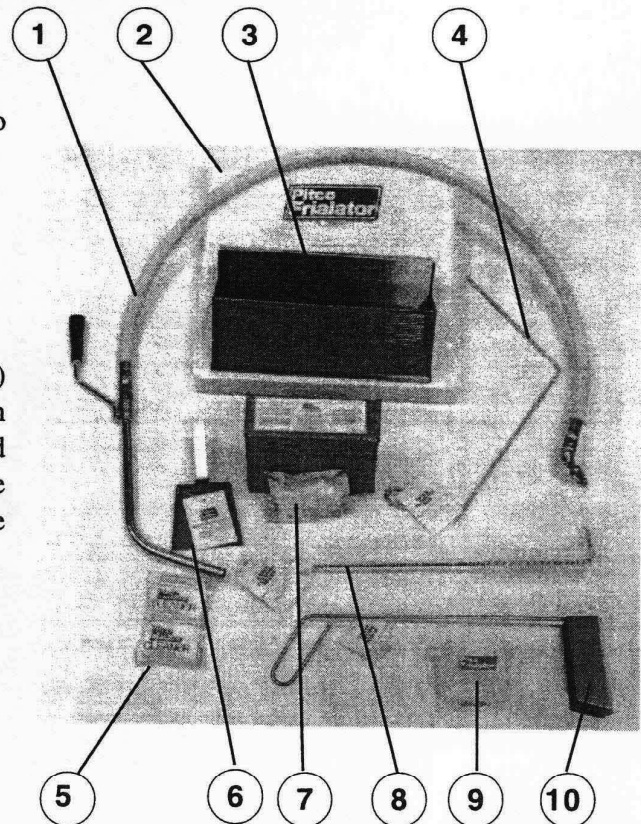

Figure 1-1 Filter Tools and Accessories

### 1.3 ASSEMBLY AND LEVELING

When you receive your fryer it is completely assembled with the possible exception of the legs (or casters). In some cases, if you have purchased a multi-fryer unit, some simple assembly may be required.

#### 1.3.1 Leg/Caster Installation and Adjustment

Installing the legs and leveling the fryer is done with a 7/16" wrench, socket, and a large pair of water pump pliers. The legs must be installed before connecting the unit to the electric supply. The legs provide the necessary height to meet sanitation requirements. Attach the legs by performing the following procedure.

- Lay the fryer on its side being careful not to damage the element junction box by pulling on it. Protect the outside of the fryer with cardboard or a drop cloth when laying it down.
- Attach each leg/caster with the hex head cap screws supplied with the fryer. Each leg/caster requires four 1/4-20 x 5/8" cap screws.
- Mount the screws from the inside of the fryer with the nut on the outside of the fryer. The nuts have lock washers attached to them, therefore it is not necessary to use lock washers.
- When all four legs/casters are mounted, stand the unit up being careful not to put too much weight on any one leg/caster. Adjust the height and level the fryer by turning the leveling devices on the leg/caster with the water pump pliers.
- On units with casters, move the fryer to the desired location and lock the wheels using the locking devices on the sides of the casters.

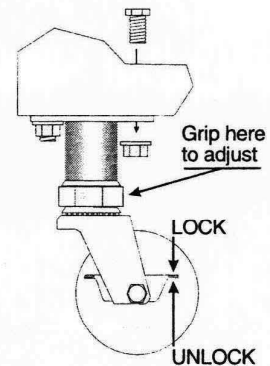

#### 1.3.2 Assembling Multi Fryer Systems

If you purchased a multi-fryer unit it could be shipped in more than one piece. To assemble the unit follow the instructions below:

- Unpack the units and move them close together. Remove the front panels from the fryers.
- There are three joining strips to be attached to the units to make the units into one system. These strips are attached in the rear, front, and upper front. Use the screws supplied with your system to attach the strips. Secure them tightly to each unit.

- c. Connect the filter return piping and the drain manifold. If possible test the pipes for leaks before completing the installation.
- d. Replace the front panels to complete the system assembly.

### 1.3.3 Basket Lift Access

The basket lift mechanisms are installed at the factory and do not need adjustment. If it becomes necessary to gain access to the basket lift motors or linkage, the rear panel of the cooker must be removed. The motors do not require periodic lubrication.

## 1.4 INSTALLATION

Although it is possible for you to install and set up your new fryer, it is **STRONGLY** recommended that you have it done by qualified professionals. The professionals that install your new fryer will know the local building codes and ensure that your installation is safe.

### 1.4.1 Installation Clearances

The fryer needs clearance around it for proper and safe operation. These clearances provide adequate distance to prevent combustible materials from coming in contact with hot fryer surfaces. The clearances shown are for cooker installation in combustible and non-combustible construction.

	Combustible Construction	Non-Combustible Construction
Back	6"	0"
Sides	6"	0"
Floor	4-3/4"	4-3/4"

In addition to the clearances required for proper fryer operation, there must be at least 28 inches of aisle space in front of the fryer to remove/install the filter pan/module.

### 1.4.2 CO<sub>2</sub> Fire System

Your new fryer has a CO<sub>2</sub> tie in that is designed to be electrically connected to the building fire protection system. The CO<sub>2</sub> tie in is an electrical connector built into the 24 VAC fryer control system. To connect the fryer to the building fire system, remove the connector jumper.

#### CAUTION

Do not apply power to this connector. This connection must be used with a normally closed relay type system.

Cut the jumper wire and splice the ends of the wire to the building fire protection system. When this point is broken by the building fire protection system, the fryer will completely shut down. Once shutdown a fire can be quickly extinguished.

### 1.4.3 Electrical Connection

#### WARNING

The fryer must be electrically grounded in accordance with local codes. If local codes do not apply follow the requirements of National Electrical Code ANSI/NFPA 70-1990.

The electrical service used by the fryer must comply with local codes. If there are no local codes that apply, refer to the National Electrical Code (NEC) to install the service. In Canada refer to CSA Standard C22.1 Canadian Electrical Code Part 1 & 2, and local codes. The type of power supplied to the fryer is dependent on the model of the fryer. While the fryers can be configured to accept a variety-of electrical power, the heating elements are designed for a particular voltage range.

#### WARNING

Before proceeding with installation, ensure that the switch(s) marked OFF-ON-START are in the OFF position. Also ensure that all the circuit breakers for the appliance(s) are OPEN or OFF. NEVER connect the fryer with power applied to the power lines. Some appliances have more than one power supply. Make sure they are ALL disconnected.

Your fryer is shipped with the internal wiring connected to support the voltage and phase requirements ordered. You can verify the wiring configuration by comparing the schematic supplied, with the fryer to the wiring arrangement of your fryer. Table 1-2 provides a list of models and voltage ranges along with the heating element part number for that voltage range. Check the fryer data plate to ensure that the fryer you are installing matches the power to be supplied to it.

#### CAUTION

Connecting the fryer to the wrong power supply may cause damage to the fryer and will void the warranty.

#### NOTICE

Fryers with the UFM, Built-In filter, basket lift, or dual power supply options will require a 120 VAC, 15A, single phase, 60Hz electrical service. This service is required for the above options to work. This service is in addition to the fryer's main electrical service.

Table 1-2 Electrical Requirements for Various Fryer Models

Model Number	Voltage & Phase Arrangement	Line Current & Total Power	Heater Element Part Number
E7	208 VAC Single Phase (2 wires and a ground)	33.7 AMPS/Line 7 KW	P5046915
E7	208 VAC Three Phase (3 wires and a ground)	19.4 AMPS/ Line 7 KW	PP10599
E7	240 VAC Single Phase (2 wires and a ground)	29.2 AMPS/Line 7 KW	P5046916
E7	240 VAC Three Phase (3 wires and a ground)	16.8 AMPS/ Line 7 KW	PP10291
E7	480 VAC Single Phase (2 wires and a ground)	14.6 AMPS/Line 7 KW	P5046960
E7B	208 VAC Single Phase (2 wires and a ground)	43.3 AMPS/Line 9 KW	P5046913
E7B	240 VAC Single Phase (2 wires and a ground)	37.5 AMPS/Line 9 KW	P5046914
E7B	480 VAC Single Phase (2 wires and a ground)	18.8 AMPS/Line 9 KW	P5046917
E14	208 VAC Single Phase (2 wires and a ground)	79.4 AMPS/Line 16.5 KW	P5046920
E14	208 VAC Three Phase (3 wires and a ground)	45.8 AMPS/Line 16.5 KW	P5046920
E14	240 VAC Single Phase (2 wires and a ground)	68.8 AMPS/Line 16.5 KW	P5046921
E14	240 VAC Three Phase (3 wires and a ground)	39.7 AMPS/Line 16.5 KW	P5046921
E14	480 VAC Three Phase (3 wires and a ground)	19.9 AMPS/Line 16.5 KW	P5046919
E14B	208 VAC Single Phase (2 wires and a ground)	101 AMPS/Line 21 KW	P5046915
E14B	208 VAC Three Phase (3 wires and a ground)	58.2 AMPS/Line 21 KW	P5046915

Table 1-2 Electrical Requirements for Various Fryer Models (Continued)

Model Number	Voltage & Phase Arrangement	Line Current & Total Power	Heater Element Part Number
E14B	240 VAC Single Phase (2 wires and a ground)	87.5 AMPS/Line 21 KW	P5046916
E14B	240 VAC Three Phase (3 wires and a ground)	50.5 AMPS/Line 21 KW	P5046916
E14B	480 VAC Three Phase (3 wires and a ground)	25.3 AMPS/Line 21 KW	P5046960
E14X	208 VAC Single Phase (2 wires and a ground)	65 AMPS/Line 13.5 KW	P5046913
E14X	208 VAC Three Phase (3 wires and a ground)	37.4 AMPS/Line 13.5 KW	P5046913
E14X	240 VAC Single Phase (2 wires and a ground)	56.2 AMPS/Line 13.5 KW	P5046914
E14X	240 VAC Three Phase (3 wires and a ground)	32.4 AMPS/Line 13.5 KW	P5046914
E14X	480 VAC Three Phase (3 wires and a ground)	16.2 AMPS/Line 13.5 KW	P5046917
E18	208 VAC Single Phase (2 wires and a ground)	86.5 AMPS/Line 18 KW	P5046901
E18	208 VAC Three Phase (3 wires and a ground)	50 AMPS/Line 18 KW	P5046901
E18	240 VAC Single Phase (2 wires and a ground)	75 AMPS/Line 18 KW	P5046902
E18	240 VAC Three Phase (3 wires and a ground)	43.3 AMPS/Line 18 KW	P5046902
E18	480 VAC Three Phase (3 wires and a ground)	21.7 AMPS/Line 18 KW	P5046900
E18B	208 VAC Single Phase (2 wires and a ground)	115.4 AMPS/Line 24 KW	P5046903
E18B	208 VAC Three Phase (3 wires and a ground)	66.6 AMPS/Line 24 KW	P5046903
E18B	240 VAC Single Phase (2 wires and a ground)	100 AMPS/Line 24 KW	P5046904
E18B	240 VAC Three Phase (3 wires and a ground)	57.7 AMPS/Line 24 KW	P5046904
E18B	480 VAC Three Phase (3 wires and a ground)	28.9 AMPS/Line 24 KW	P5046952

#### 1.4.4 – Ventilation and Fire Safety Systems

Your new fryer must have proper ventilation to function safely and properly. It is very important to install a fire safety system. Your ventilation system should be designed to allow for easy cleaning. Frequent cleaning of the ventilation system and the fryer will reduce the chances of fire. Table 1-3 provides a list of reference documents that give additional guidance on ventilation and fire safety systems. This table is not necessarily complete.

Table 1-3 Ventilation and Fire Safety References

Topic	Underwriters Laboratory Document	National Fuel Gas Code Document
Grease Extractor	ANSI/UL 710-1981	ANSI/NFPA 96-1987
Ventilation Hood	ANSI/UL 705-1984	ANSI/NFPA 96-1987
Filter Unit	ANSI/UL 586-1985 ANSI/UL 900-1987	ANSI/NFPA 96-1987
Types of Fire Extinguishers and Detection Equipment		
CO <sub>2</sub>	ANSI/UL 154-1983	ANSI/NFPA 12-1989
Dry Chemical	ANSI/UL 299-1984	ANSI/NFPA 17-1985
Water	ANSI/UL 626-1984	ANSI/NFPA 13-1989
Foam		ANSI/NFPA 11-1988
Sprinklers	ANSI/UL 199-1982	ANSI/NFPA 13-1989 ANSI/NFPA 13-1989
Smoke Detectors	ANSI/UL 268-1981	ANSI/FPA 72B-1986
Fire Detection Thermostats	ANSI/UL 521-1987	ANSI/FPA 72B-1986



## 1.5 INITIAL ADJUSTMENTS

After your fryer has been installed as described in section 1.4, it needs to be checked and adjusted to ensure that it will perform as designed.

### 1.5.1 Visual Checks

Before you begin filling and adjusting the fryer, perform the following visual checks:

- a. After the fryer is in its permanent location, lock the rollers and check the levelness. Any additional leveling that is necessary can be performed as described in section 1.3.

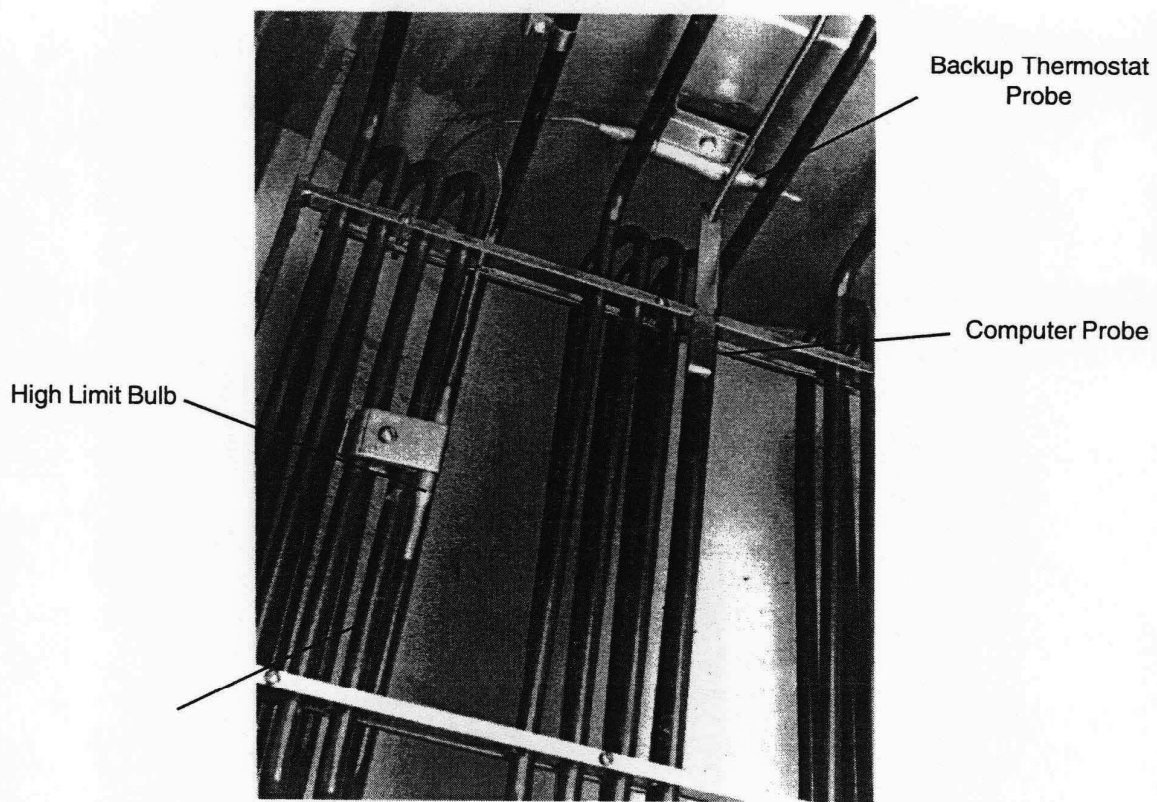

Heating Elements

Figure 1-2 Inside Fryer Tank

- b. Check the temperature bulbs (thermostat/high-limit) and other fryer tank components to ensure that the mounting screws are tight and all components are secure. Ensure that the heating elements are down and in place. Figure 1-2 shows fryer tank components.

## 1.5.2 INITIAL CLEANING

When the fryer is shipped, many of its parts are covered with a thin coat of high quality shortening for protection. Before the fryer is ready for cooking, it must be cleaned. This will remove the oil coating and any foreign matter that may have accumulated during storage and shipment. After the fryer has been installed and checked by a qualified professional, clean the fryer as described below.

### NOTICE

Since this will be the first time the fryer is turned on since leaving the factory, be observant for any unusual signs of trouble. Any time a new piece of equipment is energized there, will be some odors as new components heat up. This is normal. If odors persist or excessive smoke is seen, TURN OFF the power to the appliance at the service panel. Have a qualified technician check out the unit for the cause.

### WARNING

The heating elements **MUST** be covered with water or oil before they are turned on. **NEVER** turn on the fryer unless the main elements are covered by at least one inch of liquid.

### WARNING

All power supplies must be disconnected before servicing or cleaning the appliance. Some appliances have more than one power supply. Make sure they are **ALL** disconnected.

- a. Check the drain valve to ensure that it is closed. Fill the fryer with water to the fill line marked on the back of the tank.
- b. Press the **START** side of the **OFF-ON-START** switch and release. The switch will snap back to the **ON** position. Switch the Melt Switch to **MELT OFF**. Set the thermostat to 220°F. The **HEATING ON** light will be on while the elements are on. Bring the water to a gentle boil.
- c. If the fryer is equipped with a Pitco Matic® computer, use the Boil feature to clean the fryer. To use the Boil feature, open the fryer's front doors and turn the power on by pressing the **START** side of the **OFF-ON-START** switch. The switch will snap back to the **ON** position. On the computer press the **HOLD/BOIL** switch. The computer will energize the heating elements and bring the water to 190°F.
- d. Allow the fryer to heat for 15 minutes. Add Pitco cleaner, stirring to ensure cleaner has dissolved thoroughly.

## **NOTE**

Do not leave the fryer unattended during cleaning. Never let the water level go below the "Min Level" mark on the back of the tank.

- e. Using the fryer cleaning brush, scrub the inside of the fryer to remove protective coating.
- f. When cleaning is complete, Press the OFF side of the OFF-ON-START switch to turn the fryer off. Drain the water into a container suitable for hot water and dispose of it.
- g. When the tank has cooled, rinse it thoroughly with cool water. Continue to rinse the tank until the cleaner has been rinsed thoroughly from the tank.
- h. Using a clean dry cloth, wipe out all of the water. Be sure to completely remove all water, because any residual water will cause hot oil to splatter out of the fryer.

## **CAUTION**

Fryers with mild steel tanks must be wiped down and coated with oil to keep the tank from rusting. This must be done if the fryer is not going to be used immediately.

- i. Now that the tank is clean, you are ready to fill and operate the fryer. Refer to 2.1 for instructions on adding shortening to the fryer.

### **1.5.3 Thermostat Calibration Check - Backup Thermostat Only**

The temperature settings on the thermostat knob must match the actual temperature in the fryer for proper control of the produce being cooked. Fill the fryer with oil as described in 2.1.

- a. Press the START side of the OFF-ON-START switch and release. The switch will snap back to the ON position. Allow the computer to bring the fryer to normal operating temperature.
- b. Let the fryer cycle 4 to 6 times before checking the temperature. Open the front door of the fryer to gain access to the backup thermostat.
- c. Slowly turn the thermostat knob and listen for the thermostat to click. You can also feel the thermostat when it clicks. Although the thermostat is not controlling the fryer, its temperature probe is still sensing the temperature of the fryer.
- d. When the thermostat clicks, compare the setting on the knob to the temperature reading of the computer. If the temperature on the thermostat is within 5°F of the computer reading, the thermostat is calibrated. If the thermostat dial is more than 5°F away from the computer reading, go to step e.

- e. Remove the thermostat dial by pulling the knob straight out. DO NOT rotate the dial.
- f. Hold the outside of the shaft so it does not move. Use the tip of a small, flat tip screw driver to scrape away the sealing compound from the adjustment screw. Turn the adjustment screw clockwise to lower the temperature setting and counterclockwise to raise the temperature. One quarter turn will change the temperature approximately 25°F.
- g. Turn the adjustment until the heating elements turn off at 325°F. Replace the knob and allow the fryer to cycle 4 to 6 times. Check the temperature of the thermometer against the thermostat dial, if the difference is greater than 5°F repeat the calibration procedure.
- h. When the calibration is correct, remove the thermometer.

## Chapter 2: Operating Instructions

This chapter describes how to operate your fryer to obtain the best performance. Included in this chapter are filling, operating, and cleaning instructions for electric fryers.

### 2.1 FILLING THE FRYER

Both liquid and solid shortening can be used in the fryer, but liquid is preferred. If solid shortening is used, it is recommended that you melt the shortening and then pour the melted shortening into the fryer. If you must melt the shortening in the fryer follow step 2.1.2 for filling the fryer with solid shortening.

#### 2.1.1 Filling the Fryer With Liquid Shortening

- a. Make sure the drain valve is completely closed.
- b. Fill the fryer with oil to the "Oil Level" line marked on the back of the tank.

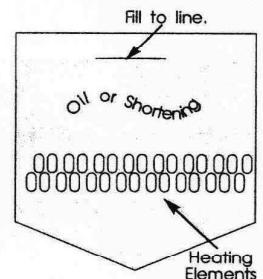

#### 2.1.2 Filling the Fryer With Solid Shortening

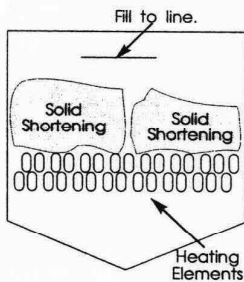

#### WARNING

Never melt blocks of solid shortening on top of the heating elements. This will cause a fire, scorch the shortening, and void your warranty.

- a. Make sure the drain valve is completely closed.
- b. Pivot the heating elements up out of the way. Cut the shortening into cubes no larger than 1". ALWAYS pack the shortening below, between, and on top of the heating elements. DO NOT leave any large air gaps. Use care when packing the solid shortening in the tank. DO NOT bend or break the temperature sensor probes. If these are damaged, the fryer will not function properly.
- c. Lower the heating elements back into the fryer and continue packing the shortening around and on top of the heating elements.
- d. Once the fryer is packed with shortening, the shortening must be melted. To melt the shortening refer to the Fryer Start Up section for your fryer.

## 2.2 OPERATING INSTRUCTIONS - WITHOUT A COMPUTER

To ensure the food always comes out the very best, follow the preparation instructions for the food you are cooking. Using the best shortening makes the best fried foods. The best shortening will last longer than lower grade shortening and save you money. When not in use, the shortening should be cooled and covered to prevent contamination.

### **WARNING**

Water and shortening **DO NOT** mix. Keep liquids away from hot shortening. Dropping liquid frozen food into hot shortening will cause violent boiling and may cause hot oil to boil out of the fryer.

#### 2.2.1 Fryer Start-Up

##### **DO NOT START FRYER WITHOUT FILLING WITH OIL!**

- a. Apply power to the fryer by closing the appropriate circuit breaker(s).
- b. Turn the temperature control knob (thermostat) to the desired temperature setting. This knob is located behind the front door(s) or on the front panel, depending on the model fryer you have. If a melt cycle is desired, press the MELT ON side of the melt switch.
- c. Turn the fryer on by pressing the START side of the OFF-ON-START switch and release. The switch will snap back to the ON position. The HEATING ON light will be on while the elements are on.
- d. **MELTING SOLID SHORTENING** - The melt cycle is designed to melt solid shortening without scorching it. During melt the heating elements will cycle on for 4 seconds and remain off for 26 seconds. This will heat the shortening slowly to 150°F (65°C). At 150°F the heating elements will remain on constantly until the shortening reaches the thermostat setting. Anytime the shortening temperature is below 150°F, the melt cycle will automatically be working. To turn the melt cycle off, press the MELT OFF side of the Melt switch.
- d. The temperature control system will maintain the shortening temperature at the desired level by cycling the heating elements as necessary. The fryer is now ready for cooking.

### **2.2.2 Automatic Basket Lifts (OPTIONAL)**

Before using the basket lifts, ensure that the shortening is up to normal operating temperature.

- a. Set the timer to the desired time and press the center button and release. The basket will lower into the shortening. When the time is up, the basket will automatically rise out of the shortening.
- b. The timers for each fryer can be set independent of each other to allow for greater frying flexibility.

### **2.2.3 Fryer Shut-Down**

Shutdown the fryer by pressing the OFF side of the OFF-ON-START switch. The fryer is now shutdown and can be cleaned or serviced.

## **2.3 OPERATING INSTRUCTIONS - WITH A COMPUTER**

Always observe the safety precautions described in the front of this manual before operating the fryer. Because fryer operation is controlled by the computer, start-up and operation is very easy. The instructions below describe how to operate the fryer to perform daily fryer operation. Detailed programming instructions are provided later in this chapter in section 2.4. Fryer covers are available from your distributor.

### **2.3.1 Fryer Start Up**

- a. The fryer power switch is inside each fryer's front door. Press the START side of the OFF-ON-START power switch and release. The switch will snap back to the ON position. The computer display will light up.

### **2.3.2 Product Selection**

Place the product in the fryer basket being used and press the computer button for the product. Place the basket in the fryer tank. The illustration shows a product being prepared using the fries program. Once pressed, the display on the computer console will change to show cooking time for the product.

### **2.3.3 Shutdown**

Shutdown the fryer by pressing the OFF side of the OFF-ON-START switch. The fryer is now shutdown and can be cleaned or serviced.

### **2.3.4 Power Failure**

If power is removed from the unit for any reason, it will shut down. To restart the fryer, follow the Fryer Start-



## 2.5 THE INTELLIFRY COMPUTER

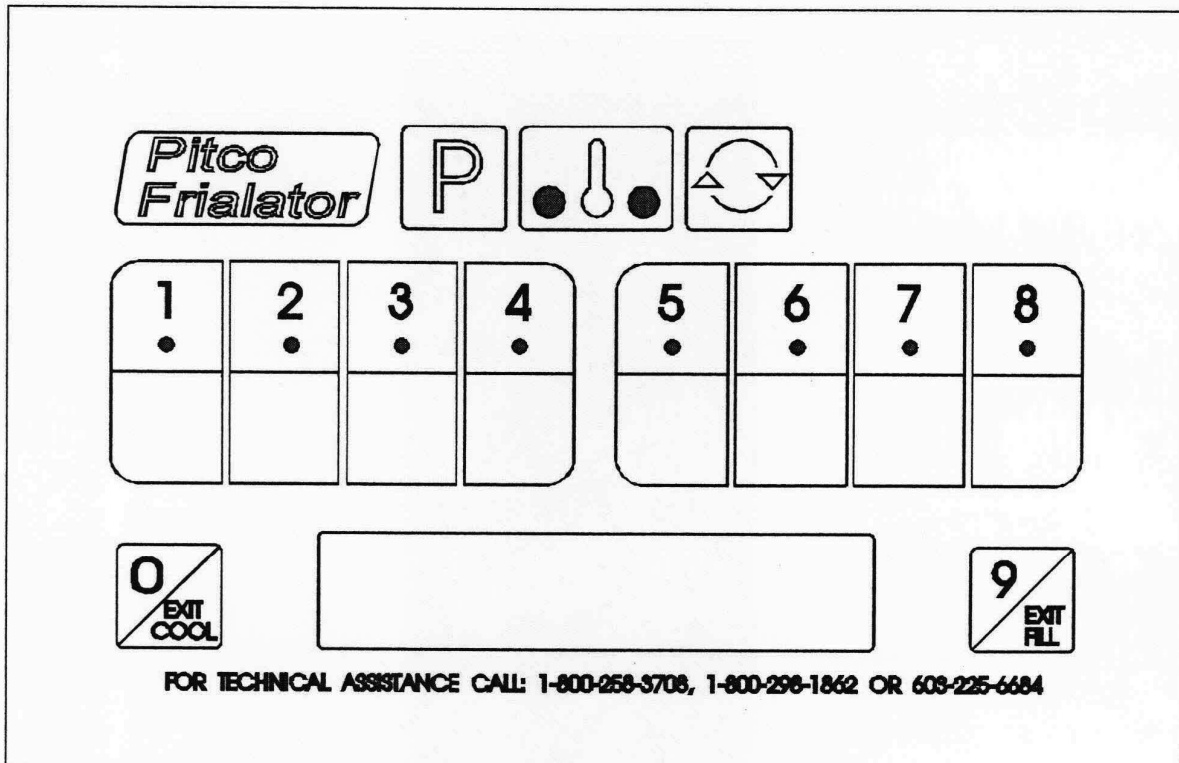

This section describes how to program the Intellifry computer. The computer monitors and controls the entire operating cycle of both frying baskets. The controls on the left of the control panel are for the left fry basket, and the right basket is operated from the controls on the right. The illustration below shows the Intellifry Multi Product computer control panel.

Your computer is fully programmable to satisfy all of your frying needs. To ensure proper product preparation, always refer to in house guidelines for cooking when changing the program. Each of the programmable features are described in the following paragraphs.

### NOTE

When programming the features of the computer, programming information will be displayed in the corresponding display window except on the Model I8.

**Melt Cycle.** The melt cycle of the fryer is used to soften and melt solid shortening. This is important to prevent scorching and extend the life of the shortening. During the melt cycle the heat is pulsed until the temperature of the shortening reaches 160°F. Once the temperature reaches 160°F the fryer switches to the constant (full) heat mode. The fryer comes from the factory with the melt cycle turned on.

**Cook Time.** The cooking time for a product can be changed to meet the needs of any recipe. The time set for a product is the time necessary at the SET temperature to cook the product. The Intellifry computer will compensate for any change in the shortening temperature by increasing and decreasing the cooking time. For this reason, when a product is cooking the time displayed is elastic time, not actual time. When you put a product in the tank and start the timer, the shortening temperature will drop. The computer senses this drop and extends the cook time to ensure that the product will receive the proper cooking time.

**Shake Time.** An alarm will sound at a preset time to tell you to stir or shake the product. DO NOT lift the product out of the shortening.

**Temperature.** The shortening temperature for each fryer is set separately and maintained by the computer. Only one SET temperature is allowed in each computer, so products being cooked in the left side must be cooked at the same temperature as the right side.

**Boil.** The Intellifry computer has a special boil mode program built into it. This program temperature cannot be reset. The boil mode will raise and hold the temperature of the fryer at 195°F. To enter the boil mode simply start the fryer as normal, the computer will sense that the water in the fry tank has reached 212°F and is not increasing. At this time the computer will display "BOIL" and lower the temperature to 195°F. The boil mode is exited by turning the fryer ON when there is oil in the fry tank. The computer will sense that the temperature has risen above 212°F and continue to heat normally. Boil mode is used during weekly cleaning of the fryer described in the maintenance section of this manual.

**Computer or Probe Failure.** If there is a probe (device used for sensing the temperature of the oil in the fry tank) failure or a problem with the computer, temperature control will automatically transfer to the auxiliary thermostat. The transfer is controlled by the computer and a transfer relay. If, for any reason, the relay becomes de-energized, temperature control will transfer to the auxiliary thermostat. Once the problem has been corrected, (the computer senses that the problem has been corrected or the power is restored to the transfer relay) temperature control will transfer back to the computer.

#### 2.4.1 Checking the Temperature functions and Cooking times.

To check the ACTUAL temperature press the  once.



To check the SET temperature press the  key two times. After 5 seconds the display will return to normal.

To check the COOK, SHAKE and HOLD times press the  followed by the product key you wish to check. The times will be displayed in sequence followed by a short pause, finally returning to the normal cook mode.

When the computer is calling for heat the two lights in the lower corners of the  key will illuminate.



#### 2.4.2 Programming Cook Time, Shake Time and Hold Times.

To set the COOK time press the  key then the  key. Enter the desired product key and change

the desired time by using the numbered keys. Press the  key to set the corresponding SHAKE time using the numbered keys. Press the  key to set the corresponding HOLD time using the numbered keys. Pressing the  key two times at any point during this procedure will return you to the normal cook mode.



### 2.4.3 Programming Cooking Temperature



This setting determines the thermostat setting for the computer. Unlike conventional thermostats, once the computer is set it will never need calibration. Set the desired temperature by performing the following procedure.





Press the  key followed by the  key. The new COOK temperature may now be set using the numbered keys. Pressing the  key two times at any point during this procedure will return you to the normal cook mode.



### 2.4.4 Level 2 Programming.



There are several features that merit mention at this point. Their programming functions are explained along with their descriptions.

To enter the level 2 programming mode press the  key followed by the  key. If a password has been set you will be asked to enter it, if you do not remember what the password is use "6684". This will allow you to program these basic functions and reset the password.

To choose between "°F" or "°C" press the  key and use the  key to toggle between the options.

To set "PASSWORD REQUIRED" or "NO PASSWORD" press the  key and use the  key to toggle between the two options. To set a new password press the  key and enter a four digit password. Press the  key again and the display will return to the normal cook mode. To continue setting level options in the level 2 programming you must re enter to level 2 programming mode in the same manner as before.

To set the beeper volume press the  key and use the  key to toggle between the options.

To set the Language option press the  key and use the  key to toggle between the options. At the time of printing the only language option available is SPANISH (ESPANOL). When a language option has been set the display will show in that language.

Pressing the  key two times at any point during this procedure will return you to the normal cook mode.

To set the melt cycle option press the **5** key and use the **0** key to toggle between the three options available. Solid shortening melt cycle (MELT S), Liquid shortening melt cycle (MELT L) or no melt cycle (NO MELT). It is highly recommended that a melt cycle is used to ensure longevity of oil and fryer.

To view the recovery test data press the **6** key followed by any numbered key to view the stored data. Each time the fryer heats through the temperature range of 250°F - 300°F it records (in seconds) the time it took and stores it as recovery data. This data can be recorded when the fryer is new and viewed again at a later date to see whether the fryer is performing correctly.

To set the control mode press the **7** key and use the **0** key to toggle between the options. The computer may be set in a "CONTROL" mode for total computer control or in "TIMER" mode where the Auxiliary Thermostat will control the temperature of the oil and the computer will act as a timer.

To exit the level 2 programming mode at any time press the **P** key two times. This will return you to the normal cook mode.

## 2.5 The Digital Control

The Pitco Digital Controller has been designed to take the place of the standard Solid State Thermostat. It provides the operator with more functions than the Solid State without giving the operator all of the features of an Intellifry Cooking Computer.

### 2.5.1 Operating the Digital Controller

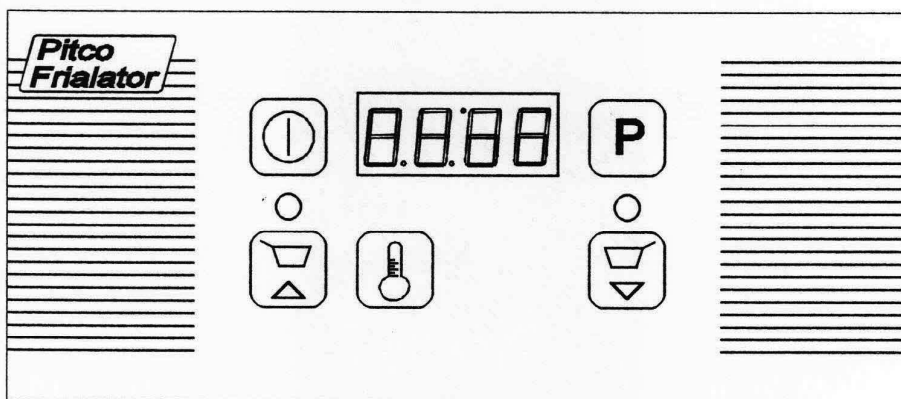

Below is listed the control functions of the Pitco Digital Controller:

Press the **⏻** key to turn the control ON. Press and hold the **⏻** key for 3 seconds to turn the control OFF.



Press the **⏸** or the **⏷** key to start the Left or Right timers.



Press the **🌡** key to display the ACTUAL Temperature. Press the **🌡** key a second time to display the SET temperature.



## 2.5.2 Programming the Digital Control



Press the **P** key to enter the program mode.







Once the program mode has been entered the display will show the LH Timer setting



**300**. An adjustment may be made by using the  or  keys.

Press the **P** key again and the display will allow you to change the RH Timer setting by using the  or  keys.

Press **P** again, the display will show **350F** and the Set Temperature may be changed by using the  or  keys.

Press **P** again, the display will show **C.P. S** and the Melt Cycle Options may be selected by using  or  keys. S may be selected to allow for a mild Melt Cycle needed for Solid Shortening. L may be selected to allow for a more aggressive Melt Cycle needed for Liquid cooking media. O may be selected to bypass a Melt Cycle.

Press **P** again, the display will show **U.L.O.C** or **.L.O.C** and the Password option may be set by using  or . If a Password Required option is programmed the Password will be   then   and is not adjustable.

Press **P** again, the display will show **. . F** or **. . C** and the Fahrenheit or Celcius option may be chosen by using  or  keys.

Press **P** again and the display will return to the LH Timer setting. To exit the Programming mode at any time, press and hold **P** for three seconds.

The following messages may also be seen in the display:

**dr.oP** indicates the fryer is ready for cooking. **HEAT** indicates the controller is in the heating mode. **.CP** indicates the controller is in a Melt cycle. **.** indicates the controller is outputting a heat signal.

## 2.6 SHORTENING FILTER PROCEDURES

This section describes the procedures used to filter fryers using either the UFM or built in filter units. Figure 2-1 shows the locations of the components used in the filter process. The fryer in Figure 2-1 is a UFM filtered unit. The callouts in the figure point to the components discussed in the filter procedure. These component locations should be representative of either filter system. Figure 2-2 shows the filter accessories and tools you should have to perform normal filtering operations. The components and accessories are described after Figure 2-2. The illustrations used with the filter procedures are provided to show where the oil is going and which valves are open. Frequent filtering of your shortening will prolong the shortening's usable life. Daily shortening filtering is strongly recommended.

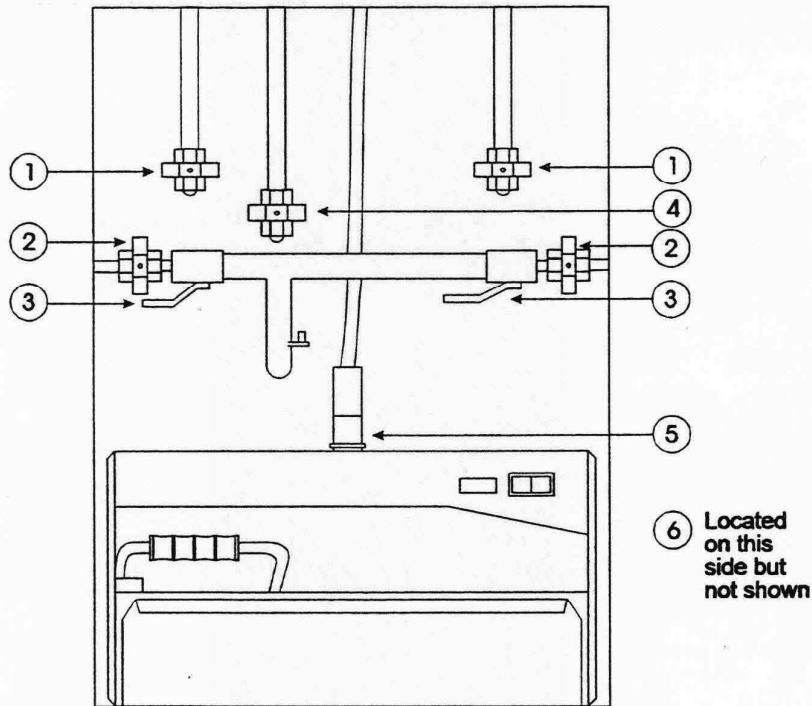

**NOTE**  
See Maintenance Section for Filter Operational Information.

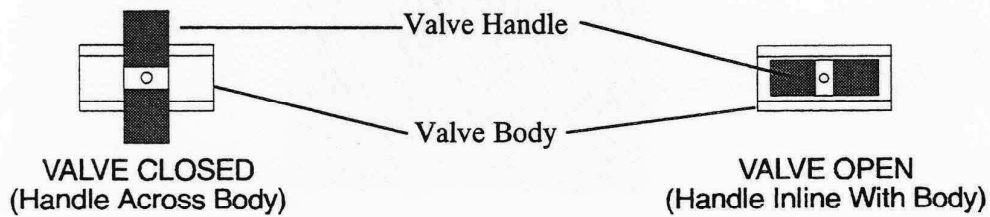

Figure 2-1 Fryer Illustrating Filter Components

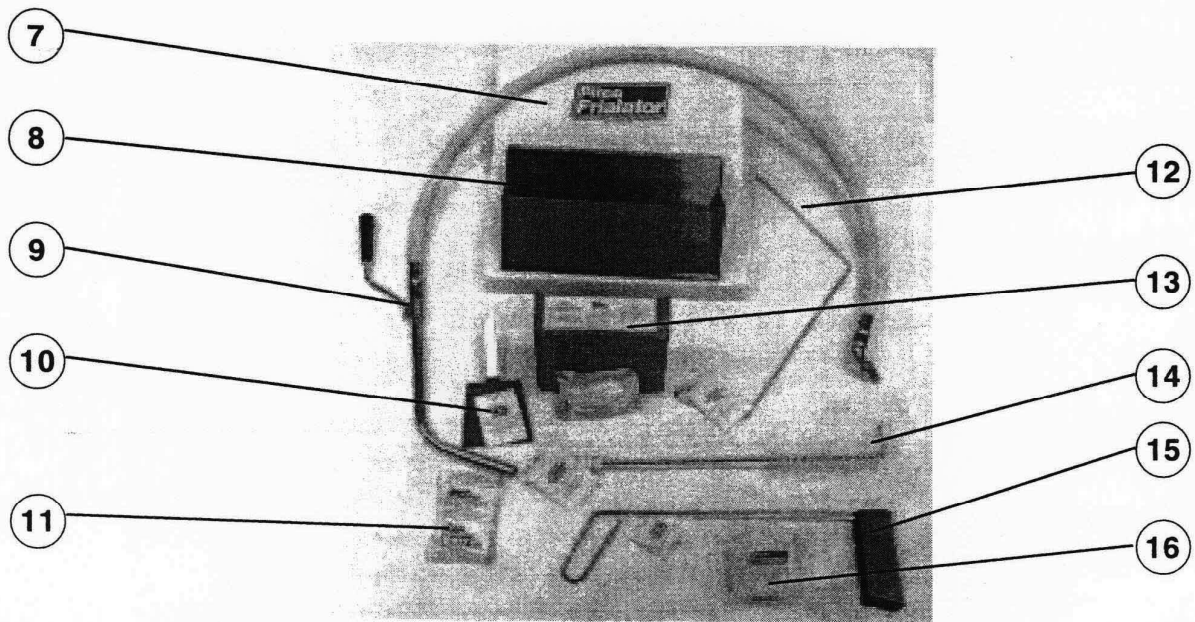

Figure 2-2 Filter Tools and Accessories

- (1) **Return Valve(s) RED** - When open, with the filter pump on, allows the shortening to return to the fryer tank.
- (2) **Circulation Valve(s) BLUE** - (Most machines are NOT equipped with these.) When open, with the filter pump on, circulates the shortening from the filter pan through the drain pipe and back to the filter pan. Circulating the oil polishes the oil and clears the drain piping.
- (3) **Drain Valve(s) GREEN** - Drain the oil from the fryer tanks to the filter pan.
- (4) **Flush Hose Connection YELLOW** - Quick disconnect and valve for optional flush hose.
- (5) **Oil Return Connection** - Quick disconnect for return oil from the filter unit to the fryer. Simply push down on fitting to connect. Lift up lower black collar to disconnect.
- (6) **Filter Unit Cord** - Provides electrical power to the filter unit.
- (7) **Filter Paper** - Package of pre-cut filter paper.
- (8) **Filter Crumb Catch** - Mounts in the filter pan and catches large debris during filtering.
- (9) **Flush Hose (OPTIONAL)** - Attached to the filter piping (4), this hose and nozzle is used to flush out the fryer tank. This hose is an optional item.
- (10) **Filter Crumb Scoop** - Short handle wide pan design, this scoop is used to remove the debris from the filter pan.
- (11) **Cleaner** - Used during fryer boil-out cleaning.
- (12) **Drain Clean Out Rod** - Long handled design, this tool is used to clean out the drain openings.
- (13) **Precoat Filter Aid** - Coarse Diatomaceous earth used to enhance the filter ability of the filter media.
- (14) **Cleaning Brush** - This long handled stiff bristle brush is used to brush down the crumbs inside the fryer tank during shortening filtering.
- (15) **Fryer Crumb Scoop** - A specially designed long handle scoop for scooping out the fryer. The scoop section is narrow enough to fit down between the fryer burner tubes.
- (16) **Precoat Measuring Cup** - Marked in ounces for correctly measuring precoat to be added to the shortening prior to filtering.

## WARNING

At operating temperature the shortening temperature will be greater than will be greater than 300°F. Extreme care should be used when filtering operating temperature shortening to avoid personal injury.

### 2.6.1 General Filter Hints

1. Ensure that all oil in the filter pan is returned before it cools and hardens. This is very important if you are using solid shortening.
2. Always use **Pitco Precoat®** for fastest filtrations, maximum labor saving, and cleanest/clearest shortening possible. Impaired filter performance will result without the use of a filter aid.
3. The longevity of your oil is related to how clean you keep it. With a Pitco built in system, it is easy to do a quick drain/refill anytime. By removing suspended particles often, it prevents them from burning.
4. When the time it takes to refill the fryer after filtering exceeds the time shown below, scrape the filter bag or paper. If scraping does not bring the refill time back down change the filter paper as described in 3.1.1 (UFM) or 3.1.2 (Built in).

<u>Model</u>	<u>Refill Time</u>
7	2:00 Minutes
14 (all models)	3:00 Minutes
18	5:00 Minutes

5. Built-In Systems - Disconnect the filter pan hose after filtering to allow the hot shortening to drain.
6. Flush Hose (Optional) - If your fryer has a flush hose allow it to drain completely before storing.
7. If you have filter system problems refer to section 3.7.3 for built-in filters and 3.7.4 for UFM filters.
8. Always check to ensure that the black quick disconnect (oil return line) is completely engaged before filtering. When connecting the quick disconnect, you will feel a definite snap and hear a click when the connection is made. After connecting the hose, gently pull on the connection to make sure it is connected.
9. The filter power **MUST** be plugged into the fryer at all times.
10. Purge the filter lines by allowing the filter pump to run 15 seconds after air bubbles are seen inside the fryer tank.



**2.6.2 Filter Procedures:** Numbers in parenthesis refer to Figures 2-1 and 2-2.

**NOTICE**

- When working with hot oil ALWAYS wear oil-proof, insulated gloves.
- Although there are differences between UFM and Built-In filters, the process used to filter the fryer is the same.

**NEVER**

- Run the filter system without a filter bag/paper.
- Attempt to filter more than one fryer tank at a time.
- Empty the oil from the fryer before turning OFF the fryer burners.
- Store the UFM Filter Unit anywhere other than in the fryer filter cavity.

- a. Disconnect the filter pan, slide it out and empty the crumb basket. Scrape previously filtered residue off the filter paper. Examine the filter bag for dark, scuffed, or torn areas. Refer to 3.1.1 for filter bag replacement instructions for UFM filters. Refer to 3.1.2 for built in filter paper replacement procedures. Re-install the pan.

- b. Turn the fryer OFF (See Standby Shutdown). Remove the baskets from the fryer tank(s). Use the clean out rod (12) to lift out the tube screens. If there are excess crumbs in the fryer tank, remove them with the crumb scoop (15).

- c. If you have replaced or scraped the filter paper, stir in Precoat Filter Aid (13) to the shortening in fryer (2 cups for a Built-In filter #14 and ll UFM filters, 3 cups for a Built-In filter #18). After cleaning out the excess debris with the fryer scoop (15) sprinkle the powder into the first fryer to be filtered and stir the powder into the oil.

- d. Check the drain spout to ensure that it is aimed into the filter pan.

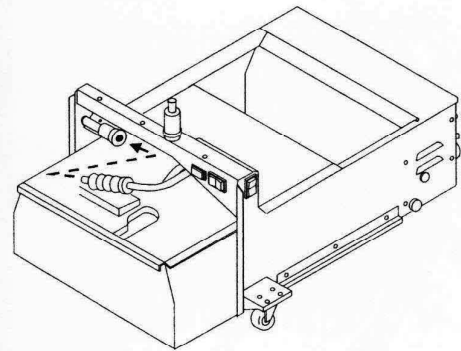

**NOTICE**

Always open a system valve before starting the filter pump.

- e. Slowly open the green handled drain valve (3) for the tank being filtered. If necessary use the clean-out rod (12) to clear the crumbs from the drain. Use the long handled brush (14) to clean the sides of the tank as the oil drains. If you have the optional flush hose (9) go to step i.

### CAUTION

The filter tank can only hold the oil from one fryer. **DO NOT** try to filter more than one fryer at a time.

### CAUTION

**NEVER** turn on the filter pump unless the PREHEAT FINISHED light (5) is on.

- f. Open the red handled return valve (1) to the tank you are filtering. When the tank is empty close the green drain valve (3) and turn on the filter pump. As the tank fills, brush the inside of the tank to remove crumbs.
- g. When bubbles are seen coming out of the oil return spout turn off the pump. Open the green handled drain valve (3) and allow the tank to drain again. Repeat steps b through d until the tank is clean.
- h. When the tank is clean, drain the shortening by opening the green handled drain valve (3). Ensure the red handled return valve (1) is shut and open the blue circulating valve (2). Allow the shortening to circulate for approximately 2 minutes. This polishes the shortening and cleans out the filter lines.
- i. **OPTIONAL FLUSH HOSE (9)** - Connect the flush hose to the quick disconnect (4). Direct the flush hose nozzle into the tank being filtered. Open the green handled drain valve (3), the yellow handled flush hose valve, and start the pump. Continue to rinse until all the debris has been removed from

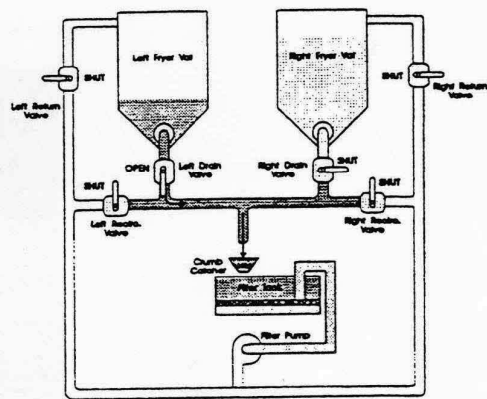

**DRAIN MODE**

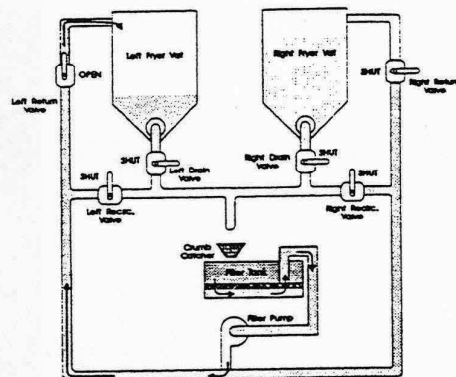

**RETURN MODE**

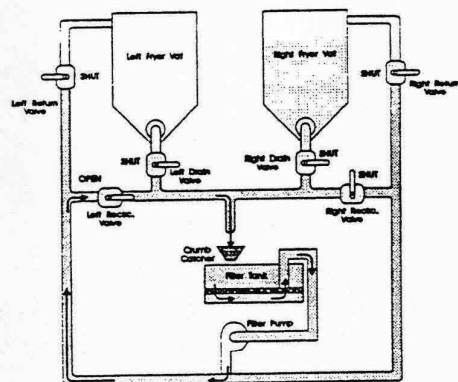

**CIRCULATE MODE**

the tank. Turn off the pump and allow the tank to drain to the filter. Close the yellow handled flush valve and disconnect the flush hose.

- j. Turn the pump off, close the blue handled circulating valve (2), and replace the tube screen. Open the red handled return valve (1) and turn on the pump to refill the fryer with the filtered oil. Continue to run the filter pump until bubbles come out the oil return opening. Turn the pump off and close the red handled return valve (1). If necessary add more shortening to the tank to return the shortening level to the fill mark. The fryer is now ready for use.
- k. If you are using solid shortening, open the blue handled recirculating valve. If the fryer is equipped with a flush hose, open the yellow handled flush hose valve (with the hose attached). Allow the oil in the filter lines to drain to the filter pan, turn on the pump for one minute. After the lines are drained, close the recirculating valve (2) and the flush hose valve.

### 2.6.3 Using The UFM Module as a Portable Filter

The UFM filter system, when used with the filter unit flush hose part # B6623201, can be moved around the kitchen to filter individual fryers. To filter other fryers follow the procedure below:

- a. Unplug the power cord from the fryer and disconnect the quick disconnect from the top of the filter unit.
- b. Move the filter unit to the appliance to be filtered. Attach the flush hose to the filter unit quick disconnect. Plug the filter unit cord into a three prong (grounded) outlet using a 3 prong (grounding) 14 AWG extension cord.
- c. Remove the filter pan lid and direct the appliance oil drain into the crumb catch. Use a drain extension connected to the fryer drain valve to allow the drain to extend over the filter pan. Be sure to wait for the Preheat Finished light to come on before turning on the pump.
- d. When finished filtering, disconnect the flush hose and empty it into a fryer. Hang the hose, nozzle down, to drain.

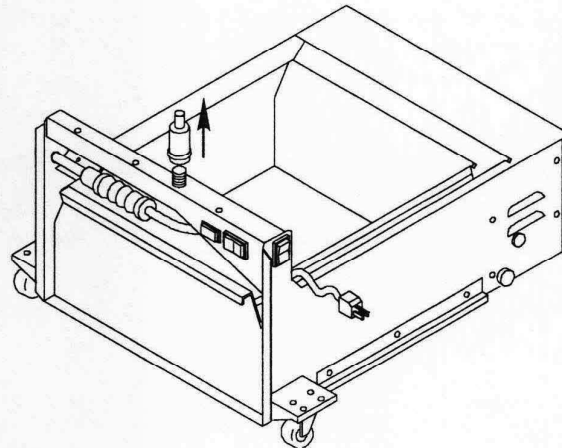

## **2.7 DAILY CLEANING**

Your fryer should be cleaned every day to maintain peak performance and appearance. Perform the procedures below every day.

- a. Wipe up any shortening that spills onto the exterior of the fryer. This should be done with a clean soft cloth while the oil is still warm.
- b. Use warm water with a mild detergent to clean surfaces. Be careful not to get water in the shortening and to remove any detergent from the fry tank.
- c. Use a non-abrasive scouring powder or pad to clean stains if necessary.
- d. Perform the weekly boil-out cleaning of your fryer described in section 3.2.

## Chapter 3: Owner Maintenance and Adjustments

This chapter provides you with the information and procedures necessary to perform basic fryer maintenance and adjustments. If after performing maintenance on your fryer it does not perform properly, contact your authorized service center.

### WARNING

The power supply must be disconnected before servicing or cleaning the appliance.

### 3.1 FILTER MEDIA REPLACEMENT

If your fryer is equipped with a filter system, it will be either a UFM or built-in filter system. While both filter systems perform the same function, they have different filter system components. This section describes each of the filter system's components and details the procedures necessary to replace the filter media. Determine which filter system you have and refer to the appropriate section.

### WARNING

At operating temperature, the shortening in the fryer may be hotter than 375°F (190°C). This hot, melted shortening will cause severe burns. Do not let the hot shortening touch your skin or clothing. Always wear insulated oil-proof gloves when working on the filter system.

#### 3.1.1 UFM Filter System

The UFM filter module, also referred to as the Spacefighter filter module, stores neatly under the fryer when not in use. The unit is very easy to use and allows for quick installation and filtration, even under the busiest conditions. The filter module is shown in Figure 3-1 with specific components and features pointed out and briefly described.

Follow the procedures below to change the UFM filter bag.

### WARNING

It will be easier and safer if the filter assembly has cooled to room temperature before handling any filter parts.

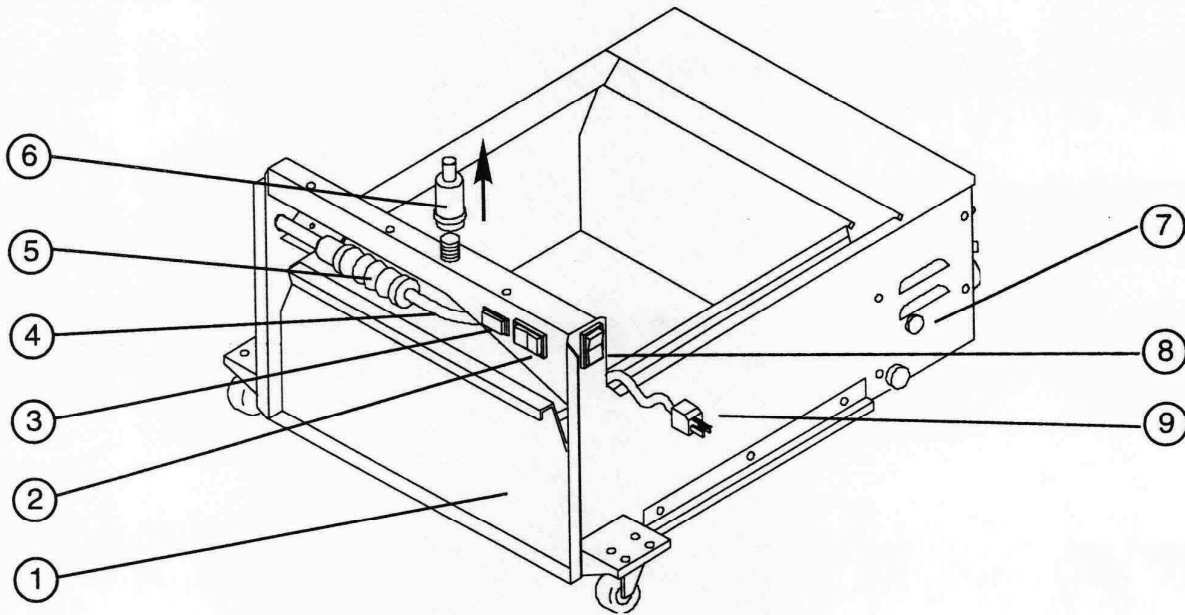

Figure 3-1 UFM Filter Module

- (1) **Filter Pan** - Holds the oil from the fry tank.
- (2) **Pump Switch** - Two position switch used to turn the filter pump ON/OFF.
- (3) **Preheat Finished Indicator** - Lights to indicate that the filter lines are warmed to filtering temperature.
- (4) **Pick-Up Tube** - Connects filter envelope assembly to piping. Incorporates a strainer to protect filter pump from grit in the event of envelope failure.
- (5) **Filter Assembly Connector** - An insulated handle covers the filter pan assembly connection. This connection separates the filter pick-up assembly from the filter piping for removing the filter pan for cleaning.
- (6) **Filter Unit Quick Disconnect** - Quick disconnect that connects the filter unit to the fryer.
- (7) **Pump Motor Thermal Overload** - (Behind cover) Protects motor from high temperatures. Trips if the pump motor is near overheating.
- (8) **Circuit Breaker** - Generally left ON. Will trip if overload occurs (i.e. pump is turned on but no system valves are open). To reset, find and correct cause of trip. Turn power switch (3) OFF. Push circuit breaker OFF, then return it to ON. Normal operation will resume.
- (9) **Power Supply Cord** - Plugs into fryer receptacle to provide power for filter operation.

## WARNING

It will be easier and safer if the filter assembly has cooled to room temperature before handling any filter parts.

- a. A unique design allows for paper replacement without the need to disconnect the filter unit from the fryer.
- b. To remove the filter pan, disconnect the filter tube connection. This is done by sliding the insulated portion (1) of the connector out of the receiving portion of the connector.
- c. Grasp the filter pan handle and gently pull the assembly toward the front of the filter unit (2). When the pan is clear of the filter unit, remove the filter pan cover.
- d. Remove the crumb catch tray from the front of the filter pan. Discard any debris that may be in the crumb catch.
- e. Lift up on the filter paper assembly and remove from the filter pan. Unscrew the suction tube from the filter paper support rack. Remove the clip screen and slide the filter paper support rack assembly out of the filter bag.
- f. All of the filter pick up assembly parts can be washed in a dish washer or a pot sink. Flush out the suction tube assembly with hot water. The pick up tube screen keeps grit and solid material from binding the pump. After flushing the pick up tube screen check to ensure that the screen is free of debris. After cleaning, it is very important to thoroughly dry the parts before re-assembling. Water and oil do not mix. Water in hot oil will cause the oil to splatter.
- g. Start re-assembling the filter pick up assembly by sliding the new filter paper on to the filter paper support rack. Ensure that the hole in the filter paper goes over the pick up tube assembly threaded connector.

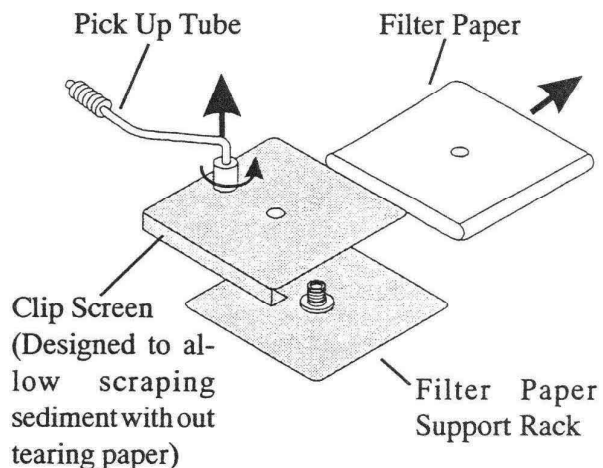
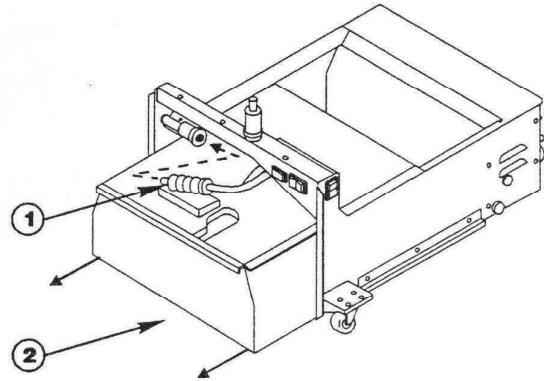

- h. Fold the open end of the bag in two folds. The first fold should be approximately 1 inch from the end and the second should be over the edge of the rack assembly.

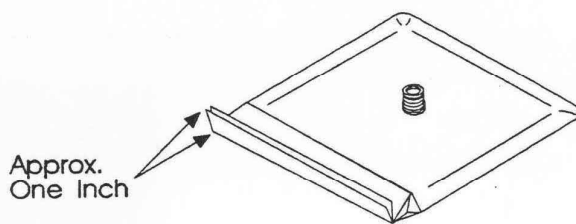

- i. Slide the clip screen over the folded end of the filter paper. Ensure the opening of the clip screen goes over the pick up tube connection. Screw the suction tube assembly onto the threaded connection.

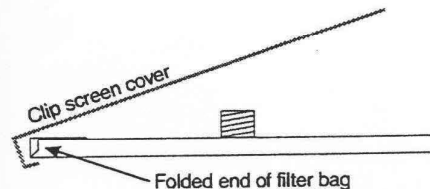

- j. Place the filter rack assembly in the filter pan and install the crumb catch tray in the front of the filter pan.
- k. Slide the filter pan assembly back into the filter unit and attach the pick up tube connector to the filter unit connection.

### 3.1.2 Built-In Filter System

The Built-In filter system is like the UFM filter system in that it is easy to use. The motor is built into the fryer and controlled from a panel mounted switch mounted on the front panel. The removable section of the filter system is shown in Figure 3-2 with specific components and features called out and briefly described.

Follow the procedures below to change the filter paper:

#### WARNING

It will be easier and safer if the filter assembly has cooled to room temperature before handling any filter parts.

- a. Disconnect the filter pan suction hose (5) quick disconnect from the right hand (white) filter fitting.
- b. If the fryer is equipped with an optional flush hose, disconnect the flush hose from the left (black) filter fitting quick disconnect. Allow the hose to drain to the filter pan.
- c. Slide the filter pan (1) out of the filter cabinet. Remove and empty the crumb basket.
- d. Scrape the filter paper (3) to remove any sediment. Unclip the filter paper retainer handles (6) from the filter pan spring clips and remove the filter paper retainer (4). Remove and discard the old paper.



- e. Thoroughly wash and clean the filter pan, crumb screen, filter paper support rack, and the filter paper retainer. Dry all the parts completely before re-assembly.
- f. Place the filter paper support rack (2) in the bottom center of the filter pan. Place a new sheet of filter paper (3) over the support rack (2).
- g. Install the filter paper retainer (4) over the filter paper (3) with the flush nozzle support rod in the front right corner of the pan. Ensure that all edges of the filter paper (3) are held in place by the retainer (4). Attach the retainer handles under the pan spring clips to hold the paper in place. Replace the crumb basket.
- h. Slide the filter pan (1) back into the filter cabinet. Connect the filter pan suction hose (5) to the right (white) filter quick disconnect.
- i. Slide the crumb basket under the drain elbow. If the unit has the optional flush hose, connect the flush hose to the left (black) filter fitting. Place the flush hose over the nozzle support rod on the paper retainer.

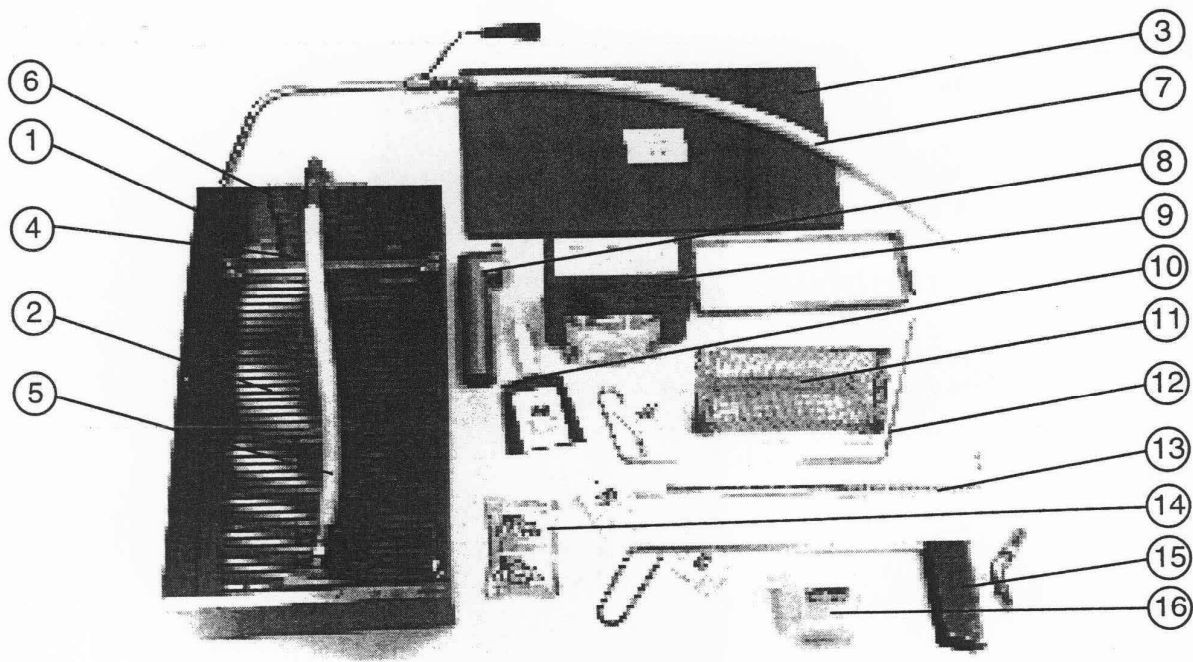

Figure 3-2 Built-In Filter System

- |   |  |
|---|--|
| <p>(1) <b>Filter Pan</b> - Holds the oil from the fry tank.</p> <p>(2) <b>Filter Paper Support Rack</b> - Provides a form for the filter paper to be held to.</p> <p>(3) <b>Filter Paper</b> - Filter media.</p> <p>(4) <b>Filter Paper Retainer Rack</b> - Fits over the filter paper on the filter paper support rack to hold the paper on.</p> <p>(5) <b>Filter Pan Inlet Hose</b> - Returns filtered shortening from the filter pan.</p> <p>(6) <b>Filter Paper Retainer Handles</b> - Snaps into place in the filter pan to hold the filter paper retainer rack in place.</p> <p>(7) <b>Flush Hose (OPTIONAL)</b> - Attached to the filter piping, this hose and nozzle is used to flush out the tank. This hose is an optional item.</p> <p>(8) <b>Boilout Extension Elbow</b> - Attaches to the oil drain to direct water to an external container. NEVER drain cleaning water to the filter pan.</p> <p>(9) <b>Precoat Filter Aid</b> - Coarse Diatomaceous earth used to enhance the filter ability of the filter media.</p> | <p>(10) <b>Filter Crumb Scoop</b> - Short handle wide pan design, this scoop is used to remove the debris from the filter pan.</p> <p>(11) <b>Filter Crumb Catch</b> - Mounts in the filter pan and catches large debris during filtering.</p> <p>(12) <b>Drain Clean Out Rod</b> - Long handled design. This tool is used to clean out the drain openings.</p> <p>(13) <b>Cleaning Brush</b> - This Long handled, stiff bristled brush is used to brush down the crumbs inside the fryer tank during shortening filtering.</p> <p>(14) <b>Cleaner</b> - Used during fryer boil-out cleaning.</p> <p>(15) <b>Fryer Crumb Scoop</b> - A specially designed long handle scoop for scooping out the fryer. The scoop section is narrow enough to fit into the small area of the fryer tank.</p> <p>(16) <b>Precoat Measuring Cup</b> - Marked in ounces for correctly measuring precoat to be added to the shortening prior to filtering.</p> |
|---|--|

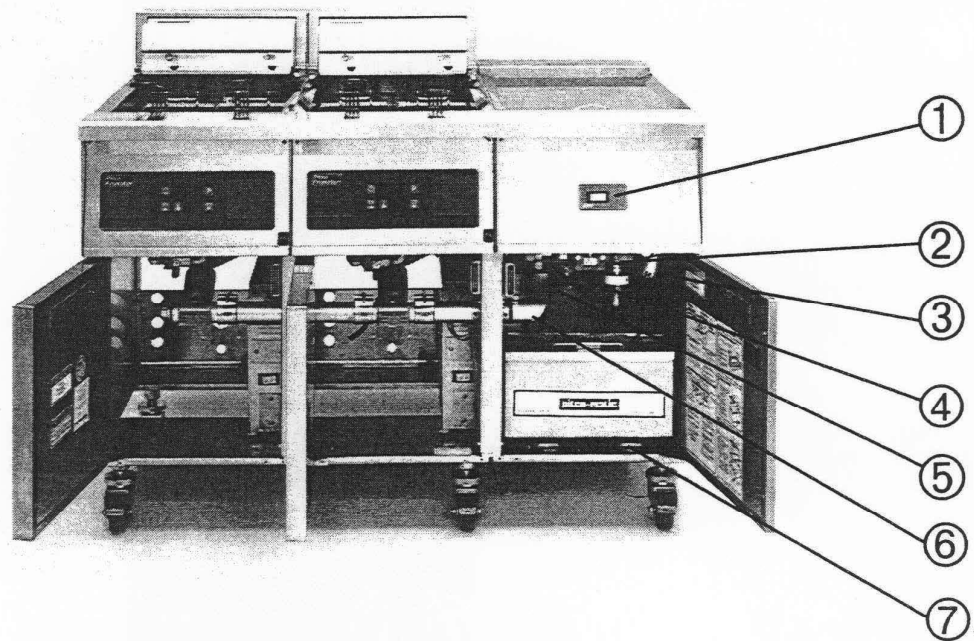

Figure 3-3 Fryer with Built-In Filter System Components

(1) **Filter Pump Switch** - Turns filter pump on to filter fryer shortening.

(2) **Filter Circuit Breaker** - Trips if overload occurs, i.e. pump is turned on but no system valves are open. To reset, find and correct the cause of the trip. Turn power switch (2) OFF. Push circuit breaker OFF, then return it to ON.

(3) **Boilout Compound Elbow Location** - The boilout elbow is used instead of the standard length elbow to drain the tank of water after a boilout cleaning. The elbow is stored inside the fryer as indicated.

(4) **Flush Hose Connection** - Quick disconnect to attach the flush hose to.

(5) **Filter Pan Connection** - Quick disconnect used to connect the filter assembly to the fryer's oil piping.

(6) **Filter Drain Elbow** - Standard drain elbow used to drain the fryer tank to the filter pan. Replace with the Boilout elbow to drain cleaning water from tank to an external pan. **NEVER DRAIN THE WATER TO THE FILTER PAN.**

(7) **Filter Pan Heaters** - (**CAUTION - Extremely hot surfaces**) - Electric heating elements used to heat the oil in the filter pan. Liquefies any solidified oil in the filter pan .

### 3.2 WEEKLY FRYER CLEANING (BOIL OUT)

The fryer should be thoroughly cleaned once a week. This cleaning should include a complete draining of the fryer and a boil out. This would also be a good time to replace the filter paper if necessary.

- a. You will need a container large enough to hold 1 1/2 times the oil in one tank. This container should also be able to withstand boiling water temperatures.

#### CAUTION

Completely shut down the fryer when the oil has been replaced by water and the heating portion of the cleaning is complete. This will prevent the heating elements from coming on during the oil draining and water filling procedure.

- b. Drain the oil from the fryer and discard or save for reuse. Pivot the heating elements up out of the way and remove any large debris from the bottom of the fry tank. Once clean, lower the elements back into the fry tank. Close the drain valve and fill the fry tank with water and noncaustic detergent. For best results use Pitco Fryer Cleaner part number P6071397 (sample packet).

#### NOTE

The heating elements have a safety feature built into them that prevents them from energizing when they are up. This interlock switch is located under the element pivot box. If the elements fail to work after they have been raised, ensure that they have been fully inserted back into place.

- c. Restart your fryer as described in 2.3 and set the thermostat to 200°F and bring the water to a slow boil. DO NOT allow water to boil because excessive foaming will occur. If you have the Pitco-Matic computer press the HOLD/BOIL button. Once the water is at a slow boil turn off the fryer.
- d. Allow the fryer to soak for 20 minutes to soften shortening deposits and carbon. Use fryer brush to remove any residue from tank, heating elements, and side walls. The heating elements can be pivoted up again to clean the under side of the elements. Perform the daily cleaning procedure described in section 2.6.
- e. Remove the filter unit from under the fryer (UFM Models) or remove the filter pan from the filter enclosure on built-in filter models. Direct the drain pipe that is normally aimed into the filter pan, into the container and open the drain valve.
- f. Built-In filter units have a longer drain spout stored above the filter pan. This longer spout makes it easier to drain the fryer. Drain the hot water to the container and rinse the tank

with clean warm water and add 1/2 cup white vinegar, stir and drain.

- g. Wipe the tank dry with clean cloth wipes. Close the drain valve and remove the large container.
- h. Refer to section 2.1 to refill the fryer.

### 3.3 INSTALLING THE OPTIONAL FLUSH HOSE

The flush hose option allows you to rinse out the fryer tank during shortening filtration. This option can be installed by the owner but it is recommended that you consult a qualified technician if you have any problems. The hardware necessary to install the flush hose option is listed below. Install the flush hose option as described in the procedures.

1	Flush Hose Assembly	(B7406501)	1	Valve Handle	(PP10050)
1	UFM Flush Hose Connection	(B6603101)	1	3/8" Valve	(P6071780)
1	Quick Disconnect - Black	(B7402241)	1	Plate for Label	(A6643402)
1	3/8" Street Elbow - Plated	(P7037752)	1	Label	(PP10057)
2	3/8" Close Nipple	(P7037301)	1	3/8" Tee	(P7036854)

- a. Remove the old 3/8" street elbow and male quick-disconnect that connects the filter return hose to the filter. Put the quick disconnect aside as you will need it later.
- b. Install the tee on the pipe where the elbow was. Install a close nipple in each of the tee's remaining openings.
- c. Attach the previously removed male quick-disconnect on the right tee opening. Install the 3/8" valve, plate, and label on the left tee opening.
- d. Install the long nipple in the 3/8" valve and the female quick-disconnect on the long nipple.
- e. Connect the filter unit to the quick disconnect and the flush hose to the flush hose quick disconnect. During normal operation of the fryer, the yellow handle flush valve will be SHUT. Only open the flush valve during the filter procedures described in 2.4.

### 3.4 BASKET LIFT LUBRICATION

The basket lift motors and linkages do not need lubrication. Oil tight bearings are used to avoid the need to lubricate these components.

### 3.5 Checking and Replacing Fuses

To check the heating element fuses you will need a general purpose OHM meter or continuity checker. The control fuses are typically glass and can be checked visually. While checking the fuses

can be performed by the user, it is recommended that a qualified technician check the fuses for you. Perform the following to check the fuses:

**WARNING**

**DANGER - HIGH VOLTAGE PRESENT**

The fuses for the fryer's heating elements and controls are located inside the power entrance box. Extreme care must be taken when opening the entrance box. **NEVER** remove the entrance box cover unless the building circuit breaker is OPEN.

- a. Remove the entrance box cover.

**NOTE**

Only use new fuses that are the same as the fuse being replaced. To ensure that you are using the correct fuses, obtain the fuses from an authorized Pitco Frialator dealer.

- b. The six heating element fuses are mounted in a fuse holder. Remove each of the fuses by gently pulling straight out on the fuse, using your fingers or a fuse puller. Do not check the fuses while they are installed because this will give false indications.
- c. Use the OHM Meter on a low resistance setting and check the fuses for continuity. The reading should be Zero ohms (approximately) for a good fuse. If the reading is significantly above Zero replace the fuse.
- d. The control fuses are also mounted in a screw type fuse holder. Remove the fuses from the holder and visually inspect the fuses for a broken or missing fuse link inside the glass fuse. You can also check these fuses using the OHM meter but typically the visual inspection will be good enough.
- e. After you have checked the fuses replace any fuses that were bad. Ensure that all fuses have been installed and replace the cover on the entrance box.
- f. If you still have problems with your fryer call a qualified service technician.

### 3.6 TROUBLESHOOTING

This section is provided to aid you in the event of fryer or filter troubles. If these troubleshooting procedures do not correct your problem contact a qualified technician or the factory. The troubleshooting procedures are in a flowchart format.

#### 3.6.1 Fryer Troubleshooting - Without a Computer

Refer to this section to correct common problems that may be encountered in equipment operation.

