



IMPORTANT FOR FUTURE REFERENCE

Please complete this information and retain this manual for the life of the equipment:

Model #: _____

Serial #: _____

Date Purchased: _____

ENGLISH

Exploded Parts Manual

PCC & PCF



NOTICE

IN THE EVENT OF PROBLEMS OR QUESTIONS ABOUT YOUR ORDER, CONTACT THE PITCO FRIALATOR FACTORY AT (603) 225-6684.

IN THE EVENT OF PROBLEMS OR QUESTIONS ABOUT YOUR EQUIPMENT, CONTACT THE PITCO FRIALATOR AUTHORIZED SERVICE AND PARTS REPRESENTATIVE (ASAP) COVERING YOUR AREA, OR CONTACT PITCO AT THE NUMBER LISTED ABOVE.

MAILING ADDRESS

PITCO FRIALATOR
P. O. BOX 501
CONCORD, NH 03302-0501

SHIPPING ADDRESS

PITCO FRIALATOR
10 FERRY STREET
CONCORD, NH 03301

TABLE OF CONTENTS

A) PCC14.....	3
EXPLODED PARTS LIST	3
EXPLODED PARTS VIEW.....	3
B) PCC18.....	4
EXPLODED PARTS LIST	4
EXPLODED PARTS VIEW.....	4
C) PCC28	5
EXPLODED PARTS LIST	5
EXPLODED PARTS VIEW.....	5
D) PCF14.....	6
EXPLODED PARTS LIST	6
EXPLODED PARTS VIEW.....	6
E) PCF18	7
EXPLODED PARTS LIST	7
EXPLODED PARTS VIEW.....	7
F) REMOTE CONTROL ASSEMBLY	8
EXPLODED PARTS LIST	8
EXPLODED PARTS VIEW.....	8

A) PCC14

Exploded Parts List

ITEM #	PART NUMBER	DESCRIPTION	QTY
1	18602-0155	GREASE FILTER	1
2	18612-0113	TUBULAR HEATER ELEMENT	2
3	15600-0061	HIGH LIMITS SWITCH	2
4	18607-0009	TERMINAL BLOCK	1
5	18309-0086	RUBBER FOOT	4
6	18602-0083	ON/OFF SWITCH	1
7	18614-0365	BLOWER WHEEL	2
8	18614-0359	INLET SCREEN	2
9	18600-0016	THERMOSTAT	1
10	18614-0362	C-FRAME MOTOR 120V	2

Exploded Parts View

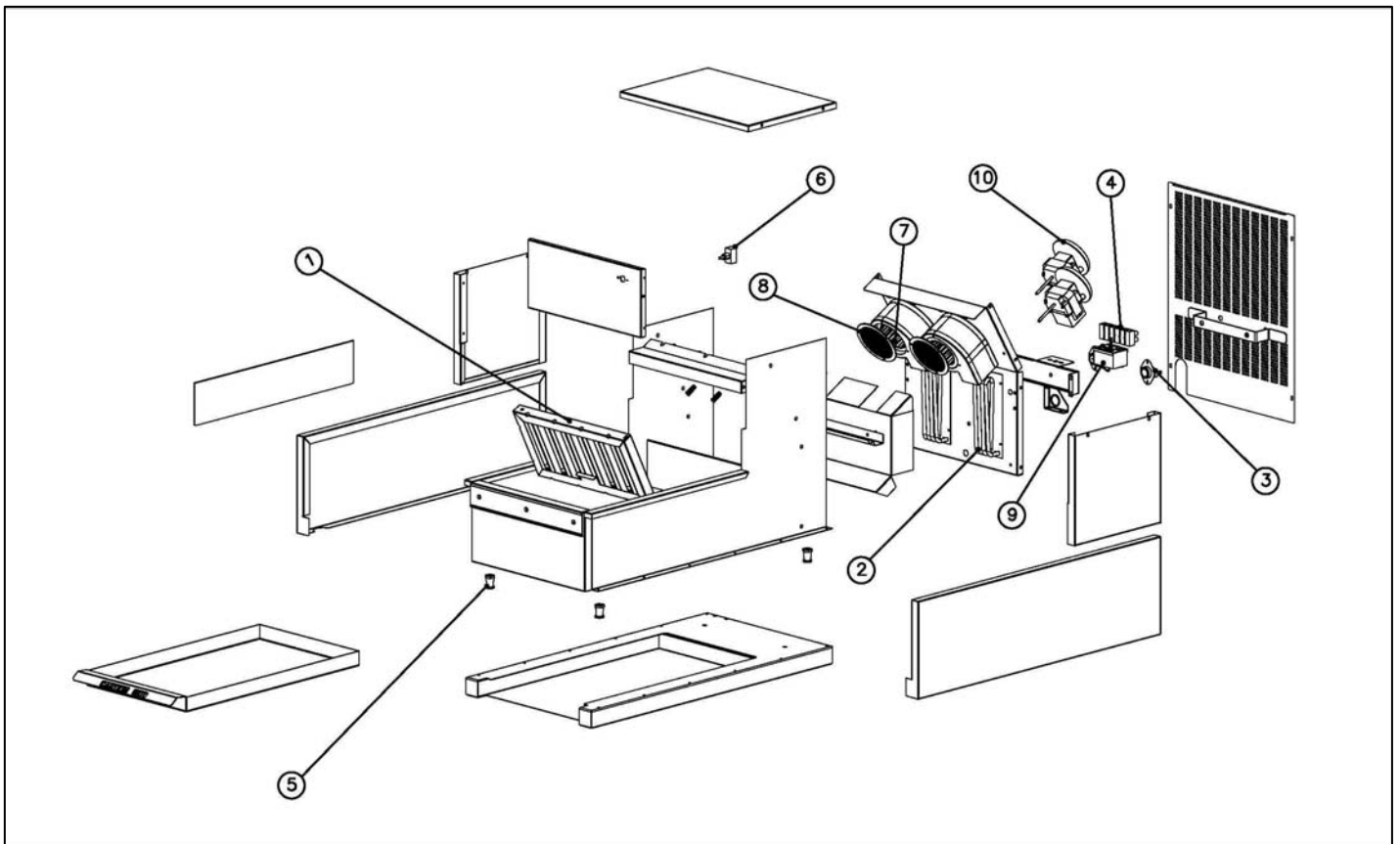

B) PCC18 Exploded Parts List

ITEM #	PART NUMBER	DESCRIPTION	QTY
1	18602-0155	GREASE FILTER	1
2	18612-0113	TUBULAR HEATER ELEMENT	4
3	18600-0061	HIGH LIMITS SWITCH	4
4	18607-0009	TERMINAL BLOCK	1
5	18309-0086	RUBBER FOOT	4
6	18602-0083	ON/OFF SWITCH	4
7	18614-0365	BLOWER WHEEL	4
8	18614-0359	INLET SCREEN	1
9	18600-0017	THERMOSTAT	1
10	18614-0362	C-FRAME MOTOR 120V	4

Exploded Parts View

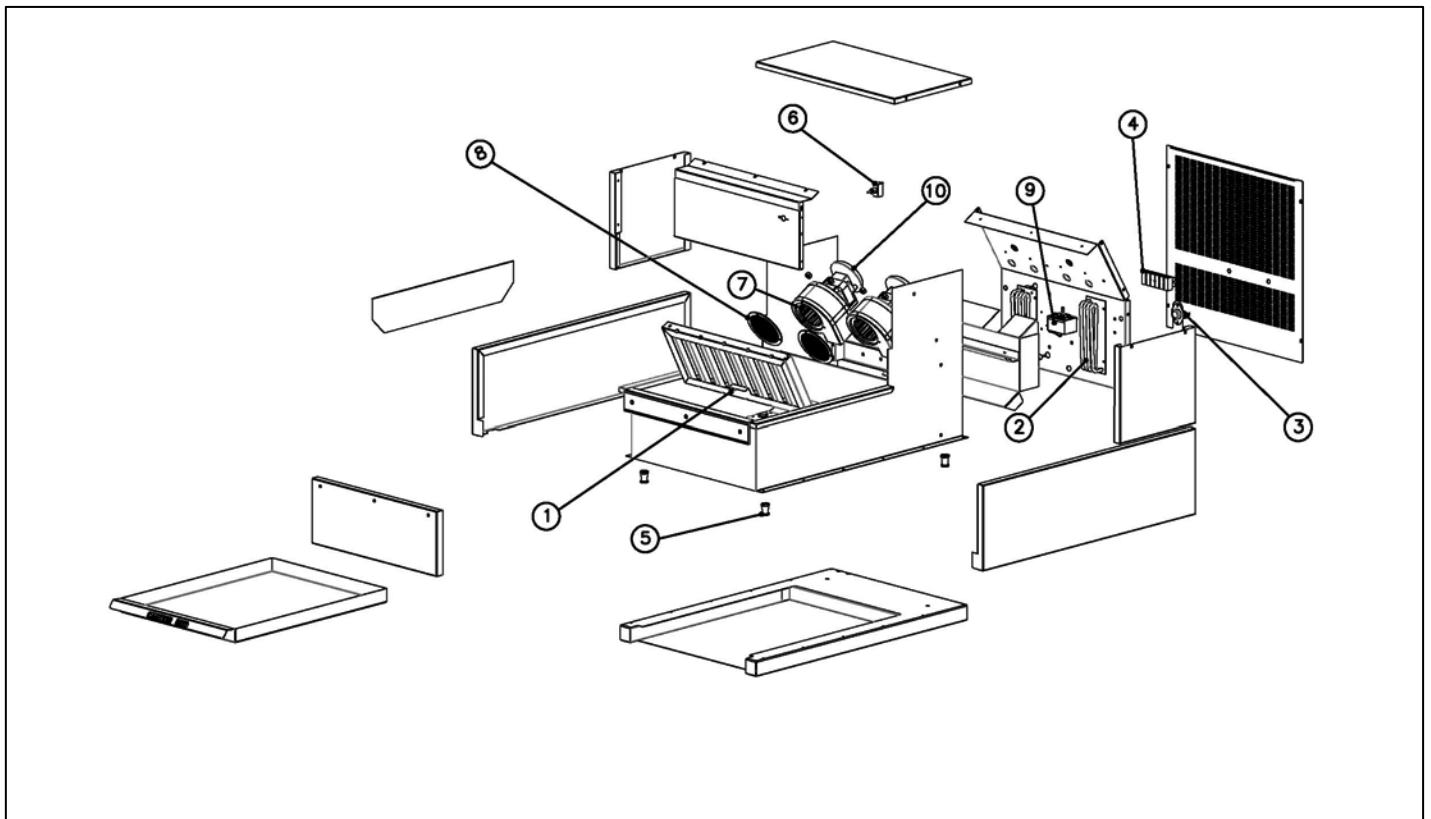

C) PCC28 Exploded Parts List

ITEM #	PART NUMBER	DESCRIPTION	QTY
1	18602-0158	GREASE FILTER	1
2	18612-0113	TUBULAR HEATER ELEMENT	4
3	18600-0061	HIGH LIMITS SWITCH	4
4	18607-0009	TERMINAL BLOCK	1
5	18305-0087	RUBBER FOOT	4
6	18602-0170	ON/OFF SWITCH	1
7	18614-0365	BLOWER WHEEL	4
8	18614-0359	INLET SCREEN	4
9	18600-0016	THERMOSTAT	1
10	18614-0363	C-FRAME MOTOR 208V	4
	18614-0364	C-FRAME MOTOR 240V	

Exploded Parts View

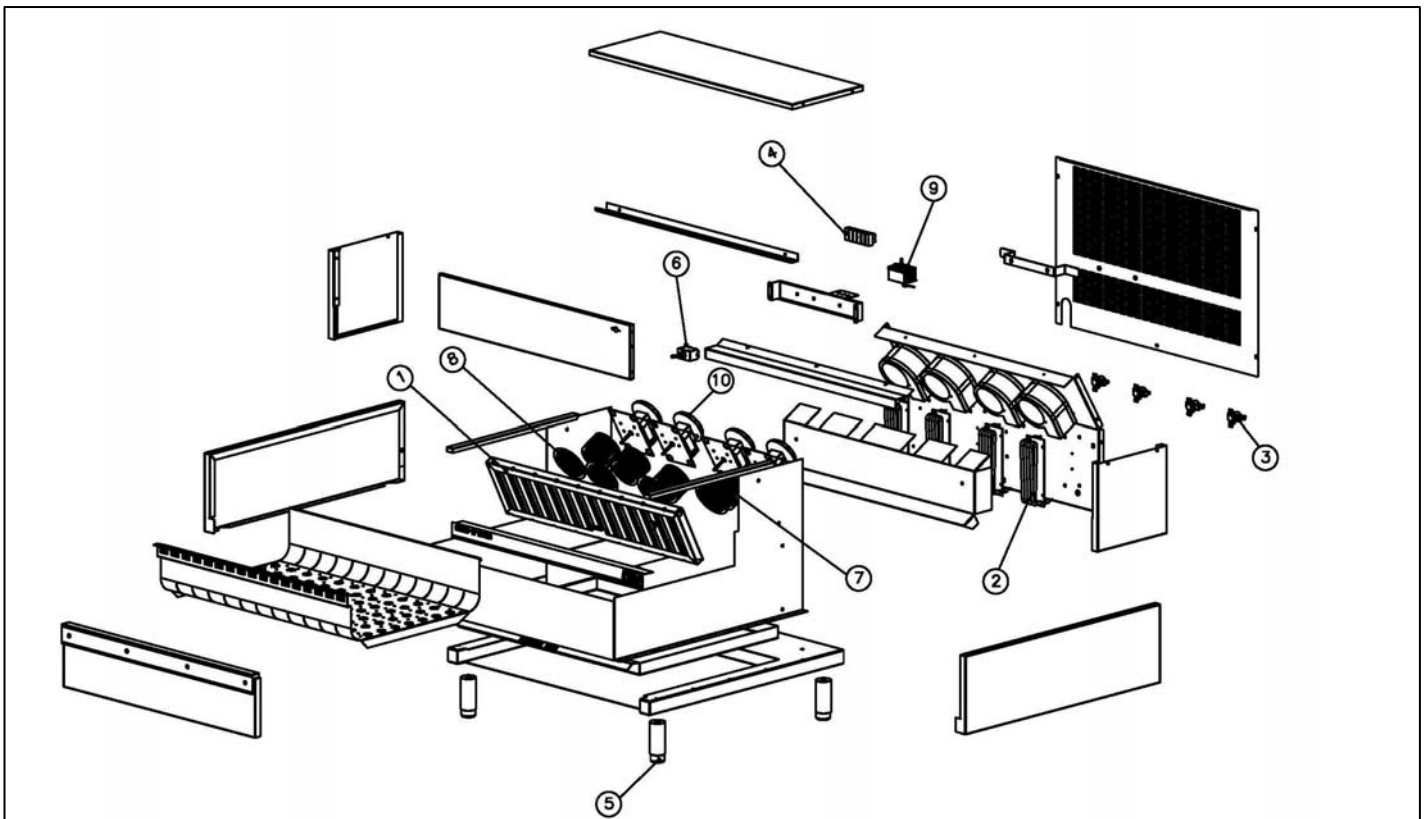

D) PCF14 Exploded Parts List

ITEM #	PART NUMBER	DESCRIPTION	QTY
1	18602-0155	GREASE FILTER	1
2	18612-0113	TUBULAR HEATER ELEMENT	2
3	15600-0061	HIGH LIMITS SWITCH	2
4	18607-0009	TERMINAL BLOCK	1
5	18616-0135	TRANSFORMER	1
6	18616-0198	PROBE	1
7	18614-0365	BLOWER WHEEL	2
8	18614-0359	INLET SCREEN	2
9	18616-0223	RELAY	2
10	18614-0362	C-FRAME MOTOR 120V	2

Exploded Parts View

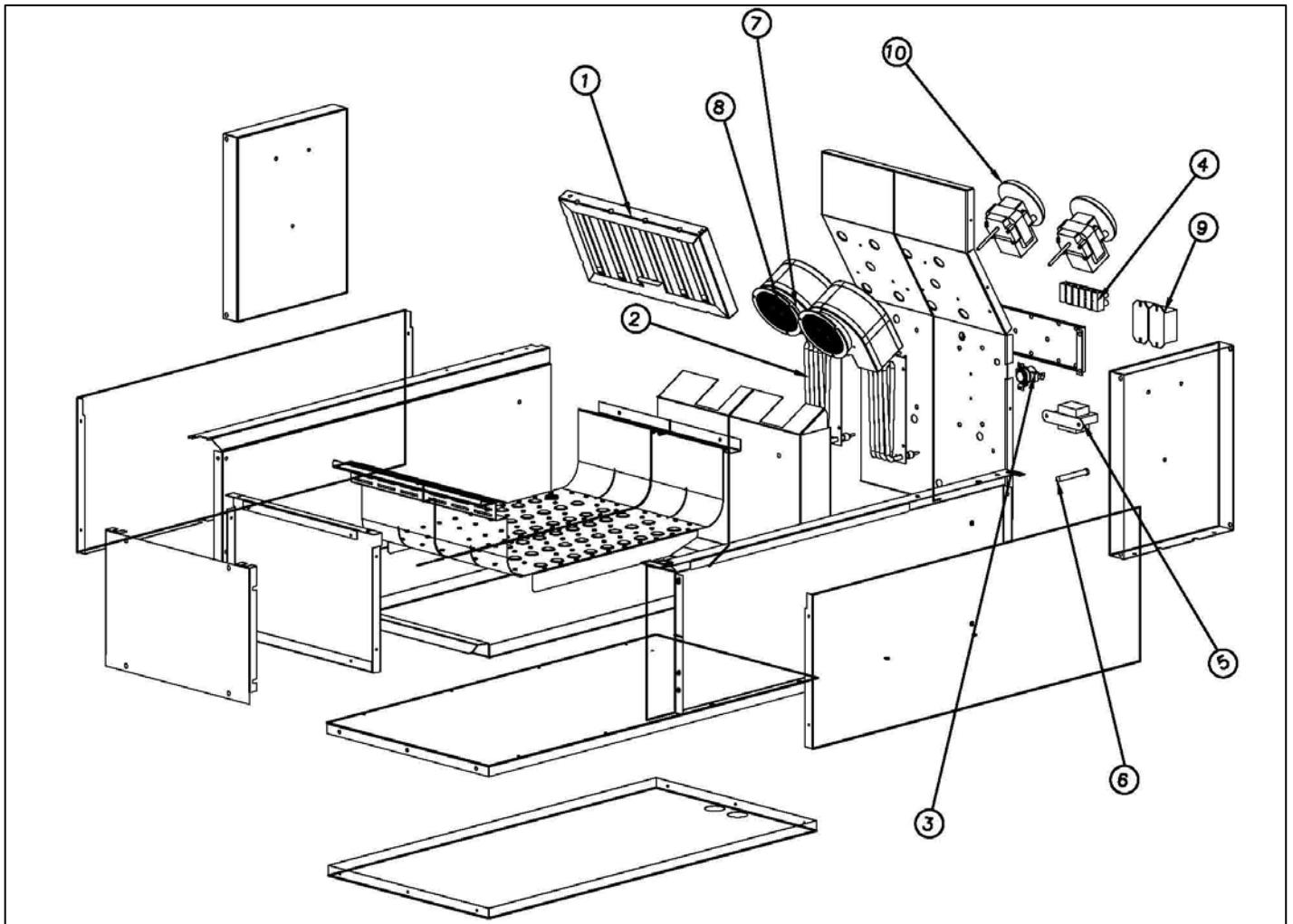

E) PCF18

Exploded Parts List

ITEM #	PART NUMBER	DESCRIPTION	QTY
1	18602-0175	GREASE FILTER	1
2	18612-0113	TUBULAR HEATER ELEMENT	2
3	15600-0061	HIGH LIMITS SWITCH	2
4	18607-0009	TERMINAL BLOCK	1
5	18616-0135	TRANSFORMER	1
6	18616-0198	PROBE	1
7	18614-0365	BLOWER WHEEL	2
8	18614-0359	INLET SCREEN	2
9	18616-0223	RELAY	2
10	18614-0362	C-FRAME MOTOR 120V	2

Exploded Parts View

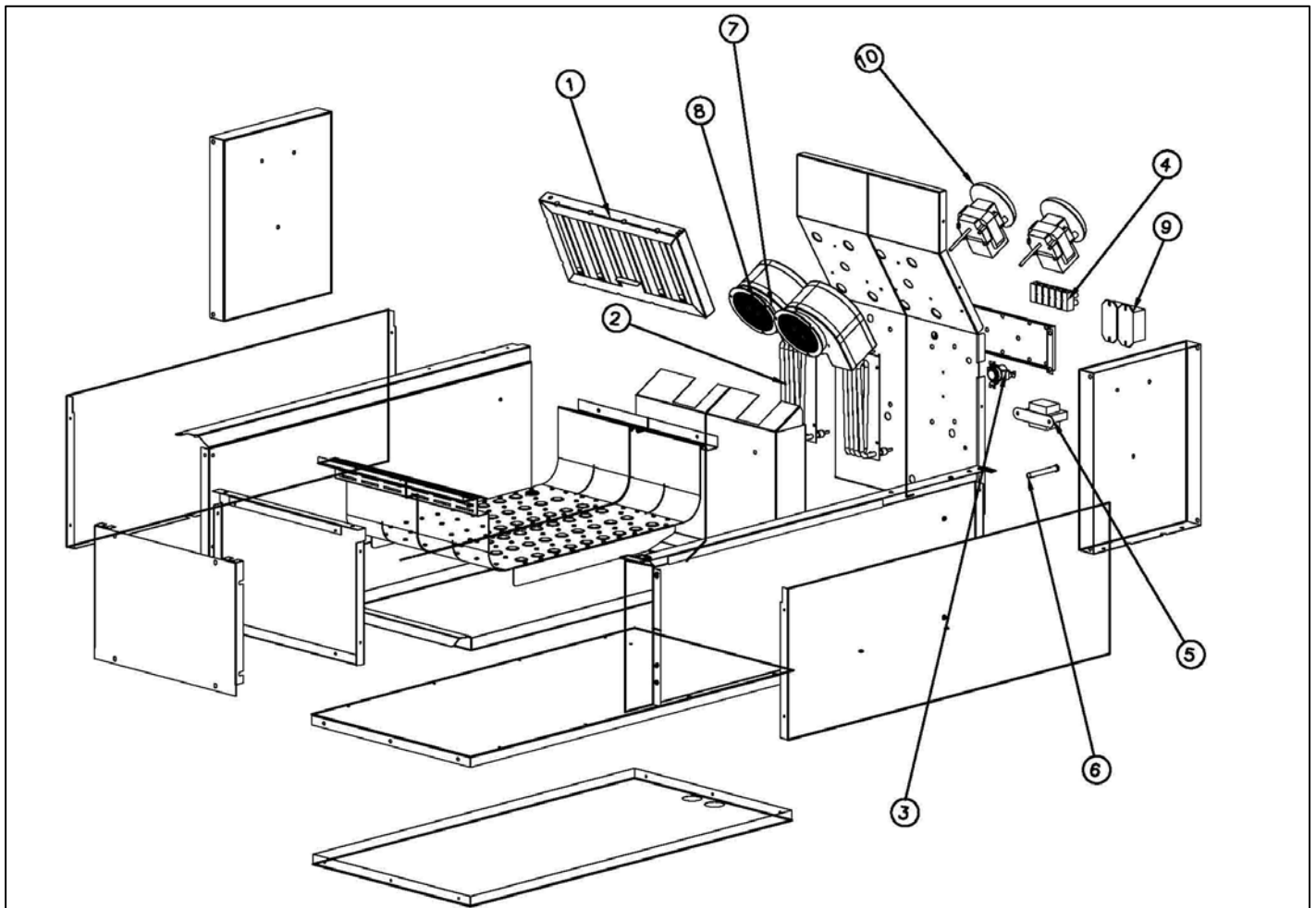

F) REMOTE CONTROL ASSEMBLY

Exploded Parts List

ITEM #	PART NUMBER	DESCRIPTION	QTY
1	18312-0189	CONTROL OVERLAY	1
2	18602-0172	ON/OFF SWITCH	2
3	18616-0229	CONTROLLER	3

Exploded Parts View

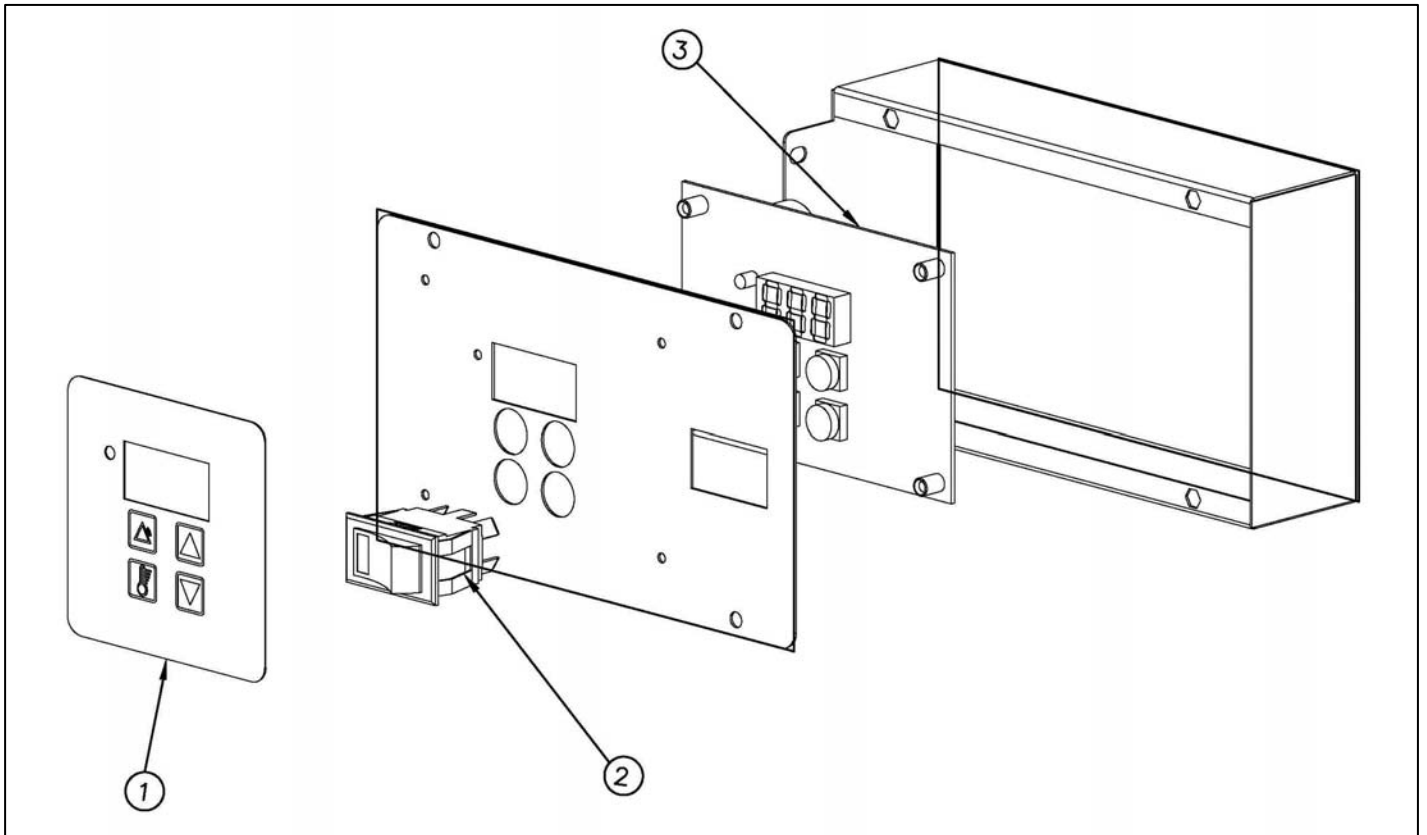



LEFT BLANK INTENTIONALLY



In the event of problems with or questions about your order, please contact the Pitco Frialator factory at

(603) 225-6684 World Wide
www.pitco.com

In the event of problems with or questions about your equipment, please contact the Pitco Frialator Authorized Service and Parts representative (ASAP) covering your area, or contact Pitco at the numbers listed to the left.

MAILING ADDRESS – P.O. BOX 501, CONCORD, NH 03302-0501
SHIPPING ADDRESS – 10 FERRY ST., CONCORD, NH 03301