



IMPORTANT FOR FUTURE REFERENCE
Please complete this information and retain this manual for the life of the equipment:

Model #: _____
Serial #: _____
Date Purchased: _____

ENGLISH

Exploded Parts Manual

SELV





WARNING

DO NOT store or use gasoline or other flammable vapors and liquids in the vicinity of this or any other appliance.

WARNING

Improper installation, alteration, service or maintenance can cause property damage, injury or death. Read the installation, operating and maintenance instructions thoroughly before installing or servicing this appliance.

WARNING

Installation, maintenance and repairs should be performed by a Pitco Authorized Service and Parts (ASAP) company technician or other qualified personnel. Installation, maintenance or repairs by an unauthorized and unqualified personnel will void the warranty.

WARNING

Installation and all connections must be made according to national and local regulations and codes in force.

WARNING

A country approved all pole circuit breaker with a minimum open contact gap of 3mm must be used for proper installation. (CE countries)

WARNING

During the warranty period if a customer elects to use a non-original part or modifies an original part purchased from Pitco and/or its Authorized Service and Parts (ASAP) companies, this warranty will be void. In addition, Pitco and its affiliates will not be liable for any claims, damages or expenses incurred by the customer which arises directly or indirectly, in whole or in part, due to the installation of any modified part and/or received from an unauthorized service center.

WARNING

This appliance, when installed, must be electrically grounded in accordance with local codes, or in the absence of local codes, with the National Electrical Code, ANSI/NFPA 70, or the Canadian Electrical Code, CSA C22.2, as applicable.

WARNING

Adequate means must be provided to LIMIT the movement or this appliance without depending on the electrical cord connection. Single appliances equipped with legs must be stabilized by installing anchor straps. All appliances equipped with casters must be stabilized by installing restraining chains.

WARNING

DO NOT alter or remove structural material on the appliance to accommodate placement under a ventilation hood.

WARNING

This appliance is intended for commercial/professional use only and should be operated by fully trained and qualified personnel. It is not intended for continuous mass production of food.

WARNING

If the supplied power cord is damaged, it must be replaced by a Pitco Authorized Service and Parts (ASAP) company technician, or a similarly qualified person in order to avoid a hazard.

WARNING

The power supply must be disconnected before servicing, maintaining or cleaning this appliance.

WARNING

The appliance is NOT water jet stream approved. DO NOT clean the appliance with a water jet or steam cleaner.

WARNING

DO NOT attempt to move this appliance or transfer hot liquids from one container to another when the unit is at operating temperature or filled with hot liquids. Serious personal injury could result if skin comes in contact with the hot surfaces or liquids.

WARNING

DO NOT sit or stand on this appliance. The appliance's front panel, tank, splash back, tank cover, work shelf, drain board is not a step. Serious injury could result from slipping, falling or contact with hot liquids.

WARNING

NEVER use the appliance as a step for cleaning or accessing the ventilation hood. Serious injury could result from slips, trips or from contacting hot liquids.

WARNING

Potential fire danger exists if the cooking oil level is below the minimum indicated level. The cooking oil level should NOT be allowed to fall below the minimum indicated level line at any time. The use of old cooking oil can be dangerous as it will have a reduced flash point and be more prone to foaming over.

WARNING

The contents of the crumb catch and/or filter pan of any filter system must be emptied into a fireproof container at the end of each day. Some food particles can spontaneously combust if left soaking in certain types of oil or shortening.

WARNING

Completely shut the appliance down when shortening/oil is being drained from the appliance. This will prevent the appliance from heating up during the draining and filling process. Serious injury can occur.

WARNING

This appliance is intended for indoor use only.

WARNING

DO NOT operate appliance unless all panels and access covers are attached correctly.

WARNING

It is recommended that this appliance be inspected by a qualified service technician for proper performance and operation on a yearly basis.

Table of Contents

A.) FRYER EXPLODED PARTS LIST	4
FRYER EXPLODED DETAIL.....	5
B.) FILTER PAN & PUMP PARTS LIST	6
FILTER PAN AND PUMP DETAIL.....	7
C.) SOLO FILTER PAN PARTS LIST	8
SOLO FILTER PAN DETAIL	9
D.) CABINET PARTS LIST	10
CABINET DETAIL.....	11
E.) TOP DECK & CONTROL PANEL PARTS LIST	12
TOP DECK & CONTROL PANEL DETAIL.....	13
F.) TANK PARTS LIST.....	14
TANK DETAIL.....	15
G.) DRAIN LINE PARTS LIST	16
DRAIN LINE DETAIL.....	17
H.) ENTRANCE BOX PARTS LIST	18
ENTRANCE BOX DETAIL	19
ENTRANCE BOX PARTS LIST B.....	20
J.) FULL PIVOT BOX PARTS LIST	22
FULL PIVOT BOX DETAIL	23
FULL PIVOT BOX PARTS LIST B.....	24
K.) SPLIT PIVOT BOX PARTS LIST.....	26
SPLIT PIVOT BOX DETAIL	27
SPLIT PIVOT BOX PARTS LIST B.....	28
L.) BASKET LIFT ASSEMBLY PARTS LIST	30
BASKET LIFT ASSEMBLY DETAIL.....	31
M.) BASKET LIFT COMPONENTS PARTS LIST	32
BASKET LIFT COMPONENTS DETAIL.....	33

A.) Fryer Exploded Parts List

ITEM #	PART#	PART DESCRIPTION
1	A1106502	BASKET HANGER,HEMMED
2	60132401	9" LEG
	B3600704	9" LEG SET OF 4 WITH HARDWARE
	60115301	9" LEG WITH BOTTOM BOLT FLANGE ADJUSTABLE
	PP10814	9" CASTER NON-LOCKING
	B3901504	9" CASTER SET OF 4 (2 LOCKING, 2 NON-LOCKING)
	B3902302	9" RIGID CASTER NON-LOCKING
	PP10815	9" CASTER LOCKING
	B3902304	9" RIGID CASTER LOCKING
3	A6613102-C	FILTER DRAIN LINE CABINET COVER SST
4	A1859202	CABINET, REAR JOINING STRIP TOP
	A1859204	CABINET, REAR JOINING STRIP BOTTOM
	A1865901	CABINET, FRONT JOINING STRIP
	A1908202	CHANNEL STRIP, CABINET JOINING
5	B2304618	DOOR ASSEMBLY, SELV14*
6	B3801801	HINGE WELDMENT LOWER RIGHT HAND SG*
	B3801802	HINGE WELDMENT LOWER LEFT HAND SG*
7	B3802401	HINGE WELDMENT UPPER RIGHT HAND SG*
	B2802402	HINGE WELDMENT UPPER LEFT HAND SG*

Fryer Exploded Detail

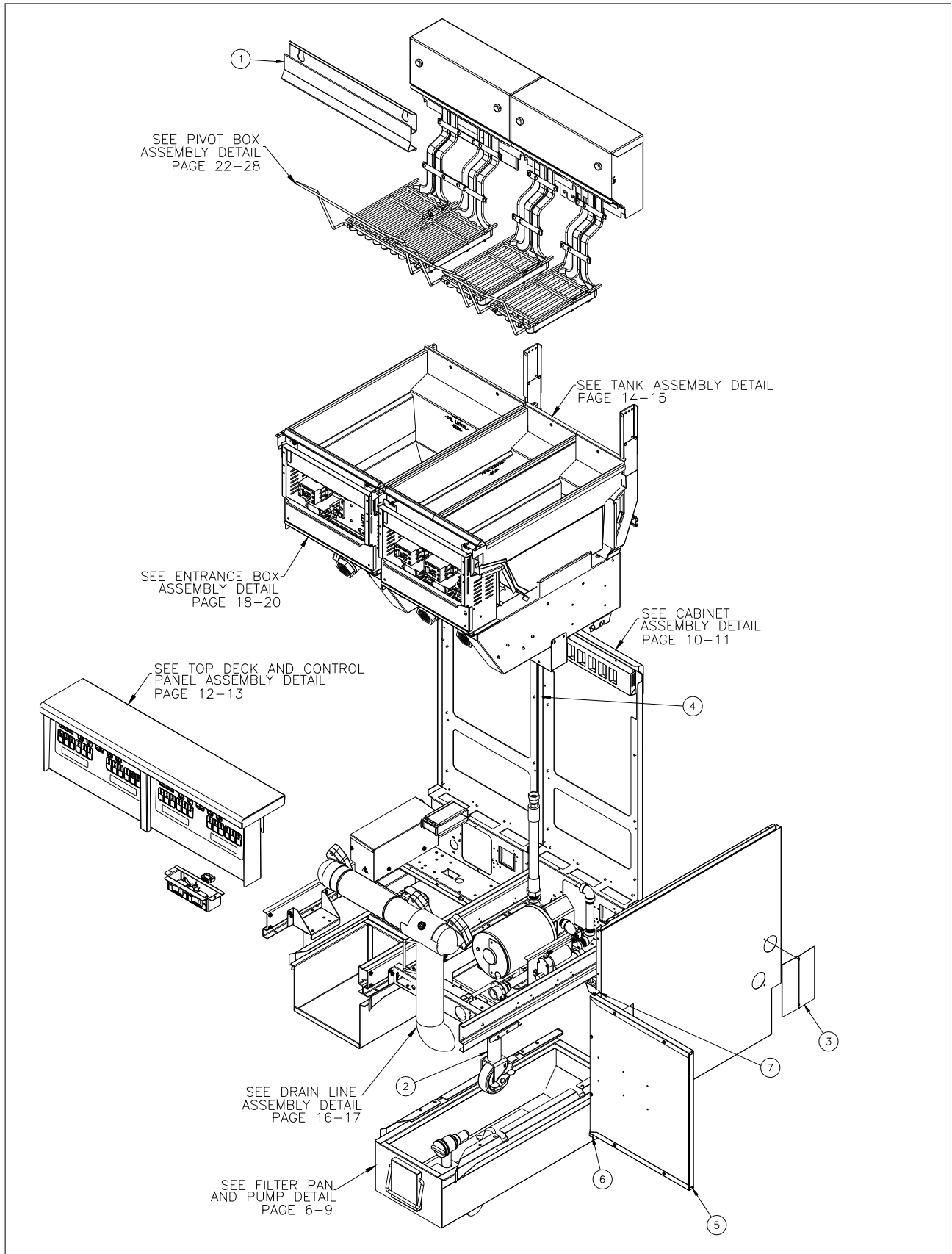

B.) Filter Pan & Pump Parts List

ITEM #	PART#	PART DESCRIPTION
1	B6673401	FILTER, WELDMENT PAN
2	B6671202	FILTER, STRAINER CAP ASSEMBLY
3	B6677401	FILTER, CLIP PAPER WELDMENT
4	B6664304	FILTER, SUPPORT WELDMENT
5	B6672501	FILTER, WELDMENT RAIL MOUNT LH
6	B6672502	FILTER, WELDMENT RAIL MOUNT RH'
7	60168302-C	WHEEL, 2" WITH AXLE AND NUT BULK PACK
8	PP11208	WASHER, LOCK #10 SST (SPLIT)
9	P0112000	BOLT, 10-24 X 1/2 HHC SST
11	A7030102	FILTER, GUIDE PICK-UP TUBE
12	B6677601	FILTER, TUBE PICKUP WELDMENT
13	PP10879	O-RING MFR. NO 217-3107
14	60136301	RING, EXTERNAL RETAINING 1-7/16"
15	60132201	HOSE, PTFE F SWIVEL X MPT
16	PP10485	ELBOW, BLACK REDUCER 90 3/4 X 1/2 NPT
17	PP11338	CORD, PLUG IEC-320 16-3 AWG 17.5
18	PP10023	SCREW, 10-24 X 3/8 SELF TAP
19	P7036013	BUSHING, REDUCER HEX 3/4 X 1/2 NPT BLACK
20	P7037109	NIPPLE, BLACK 1/2 X 10
21	P0154100	CLIP, HITCH PIN
22	P6071757	VALVE, BALL 1/2NPT 3-WAY
23	P7037678	ELBOW, BLACK 90 1/2
24	P7037099	NIPPLE, BLACK 1/2" X 5"
25	B6692801	FILTER, DIVERTER VALVE HANDLE WELDMENT
26	P7037092	NIPPLE, BLACK 1/2" X 1-1/2"
27	B6693101	FILTER, ACTUATOR BRACKET WELDMENT
28	P0082400	WASHER, LOCK #10 ZINC (SPLIT)
29	PP10828	NUT, HEX (KEP) 5/16-18 ZINC
30	P0080750	WASHER, FLAT 5/16 ZINC SAE
31	A7049301	FILTER, PUMP PLATE
32	A7049601	FILTER, PIPING CLAMP
33	P7037090	NIPPLE, BLACK 1/2" CLOSE
34	60155704	ACTUATOR, LINEAR 2" 24VDC
35	60047806	PIN, CLEVIS 1/4 OD X 1"
36	60047803	PIN, CLEVIS 1/4 OD X 1-1/4"
37	A7097301	FILTER, COVER PUMP
38	PP11261	BOLT, 5/16 X 3/4
39	60143505	MOTOR 115/230V 50/60HZ
	60143506	MOTOR 240V 50/60HZ
	60143518	MOTOR 208V 50/60HZ
40	60143508	PUMP, 4 GPM
41	A6653512	FILTER HOSE 47.75 CPF65 OUT
42	B6677001	FILTER SUPPORT INLET PG SG/SE FD/SF*
43	B6676001	FILTER, PICKUP BLOCK SGF*, SG6H
44	60068301	O-RING, VITON 1" ID X 1.375 OD

Filter Pan and Pump Detail

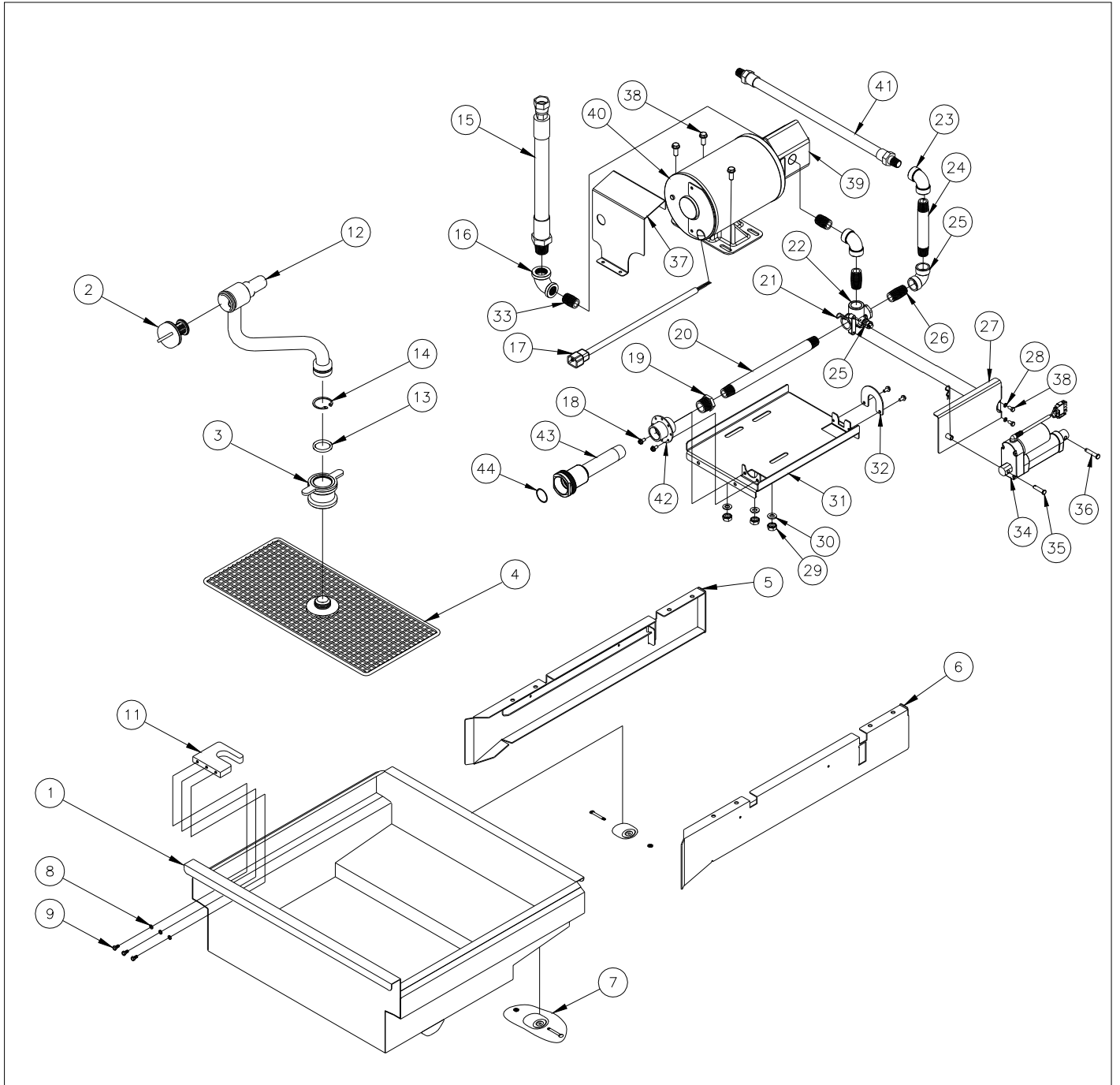

C.) Solo Filter Pan Parts List

ITEM #	PART#	PART DESCRIPTION
1	B6671202	FILTER, STRAINER CAP ASSEMBLY
2	B6673902	FILTER, TUBE PICKUP WELDMENT SFSG14
3	60136301	RING, EXTERNAL RETAINING 1-7/16"
4	PP10879	O-RING MFR. NO 217-3107
5	B6671102	FILTER, CLIP PAPER WELDMENT
6	B6664303	FILTER, SUPPORT WELDMENT
7	B6693702	FILTER, MOUNT WELDMENT LEFT SIDE
8	B6693701	FILTER, MOUNT WELDMENT RIGHT SIDE
9	B6670805	FILTER, PAN WELDMENT SFSG14
10	60168302-C	WHEEL, 2" WITH AXLE AND NUT BULK PACK
11	60077901	CIRCUIT ROCKER SPST 250V 10A
12	A7028701-C	FILTER PUMP BOX SGF*
13	A7044001	FLTR,STRN RLF PMP BOX DUAL
14	60148401	CONNECTOR POWER INLET & OUT IEC320
15	A1844001-C	CABLE RETAINER SG
16	P0075400	SCREW, 10-24 X 1/2 SELF TAP
17	P5045508	SCR,10-24 X 3/8 TH PHILLIPS
18	60130301	TRANSFORMER,5VA 120V
	60130302	TRANSFORMER,5VA 240V
	60130303	TRANSFORMER,5VA 230V
19	P0092300	NUT,HEX (KEP) 10-24 ZN
20	60128501	CORD,NEMA5-15P/IEC320 16-3

Solo Filter Pan Detail

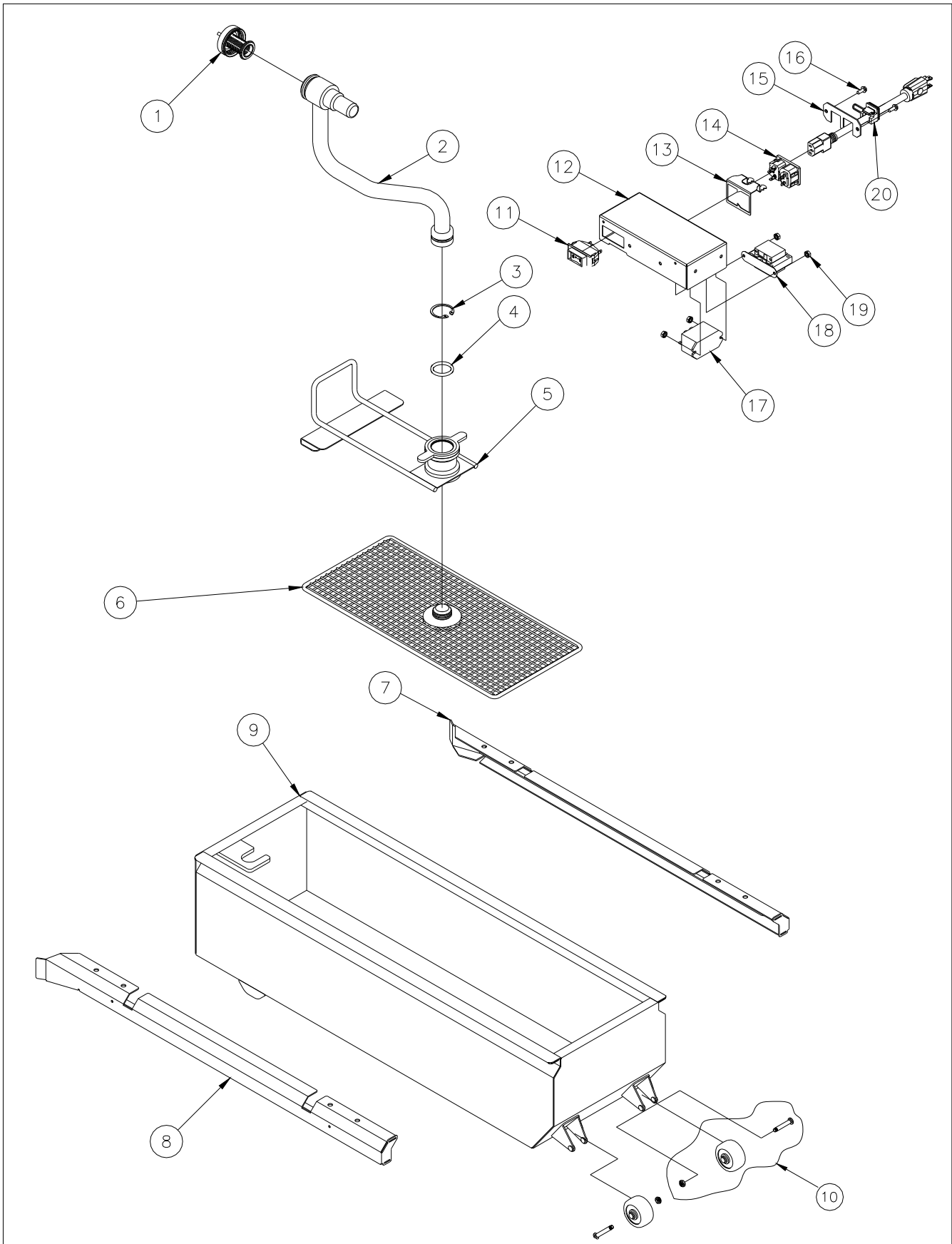

D.) Cabinet Parts List

ITEM #	PART#	PART DESCRIPTION
1	A1540602	CABINET SIDE, LEFT HAND
2	A1642001	CABINET BACK, TOP
3	A1861401	CABINET, SPACER
4	A1642101	CABINET BACK, COVER SGH50, SGH50T
5	PP10023	SCREW, 10-24 X .375" SELF TAPPING
6	A1640701	CABINET BACK, BOTTOM S*LV WITHOUT JIB
7	A5073901	ACCESSORIES, JIB PAN RAIL SUPPORT
8	A1540501	CABINET SIDE, SUPPORT
9	A1542004	CABINET SIDE, RIGHT HAND
10	A1238501	CABINET, BOTTOM BRACE FRONT S*LV
11	60066801	SCREW, 4-40 X .250" RDH ZINC
12	B53050001	ELECTRICAL ASSEMBLY, DVI
13	A5074201	ACCESSORIES, JIB PROXIMITY SENSOR MOUNTING BRACKET S*LV
14	A5074301	ACCESSORIES, JIB HOSE HOLDER UPPER
15	A5074401	ACCESSORIES, JIB HOSE HOLDER LOWER
16	A1238201	CABINET, BOTTOM BRACE JIB WEIGHING
17	A1238301	CABINET, BOTTOM BRACE JIB SUPPORT
18	A5074201	ACCESSORIES, JIB SPRING MOUNTING BRACKET
19	60135202	SPRING, EXTENSION .750" OD, .080 WIRE X 2.75" (DISCONTINUED AFTER 12/13)
20	A1640703	CABINET BACK, BOTTOM S*LV WITH JIB
21	A5073801	ACCESSORIES, JIB RAIL S*LV
22	P0190200	PIN, COTTER EXT PRONG. .062 X .750 ZINC
23	B5052701	ACCESSORIES, JIB RAIL MOUNTING PIN WELDMENT S*LV
24	A2043701	CONTROL BOX, DC POWER HOUSING COVER
25	B6795701	WIRING, DC POWER BOX S*LV
26	A6051201	LABEL, HIGH VOLTAGE
28	60148401	CONNECTOR, POWER INLET & OUTLET IEC320
29	A7044001	FILTER, STRAIN RELIEF PUMP BOX DUAL IEC
30	60117203	SPACER, .126ID X .195 ODX .355L NYLON
31	PP11351	SCREW, 4-40 X .750 ROUND HEAD SLOTTED ZINC
32	A2043901	CONTROL BOX, DC POWER HOUSING BRACKET
33	A2043801	CONTROL BOX, DC POWER HOUSING
34	60175501	INSULATION, DC POWER SUPPLY S*LV
35	60092101	NUTSERT, 4-40 UNC
36	60155401	POWER SUPPLY, 24VDC 150W
37	A5074201 REV D	(USED AFTER 2/17/14) ACCESSORIES, JIB PROXIMITY MOUNTING BRACKET
38	A5074701	ACCESSORIES, JIB CAP STANDARD #35 JIB S*LV
39	A5075201	ACCESSORIES, HOSE 1/2ID X 12.75L BRAIDED SILICON
40	A5074801	ACCESSORIES, JIB HOSE WEIGHT S*LV
41	B5052401	ACCESSORIES, JIB PAN WELDMENT S*LV
42	B5052601	ACCESSORIES, SMALL JUG SUPPORT WELDMENT S*LV

Cabinet Detail

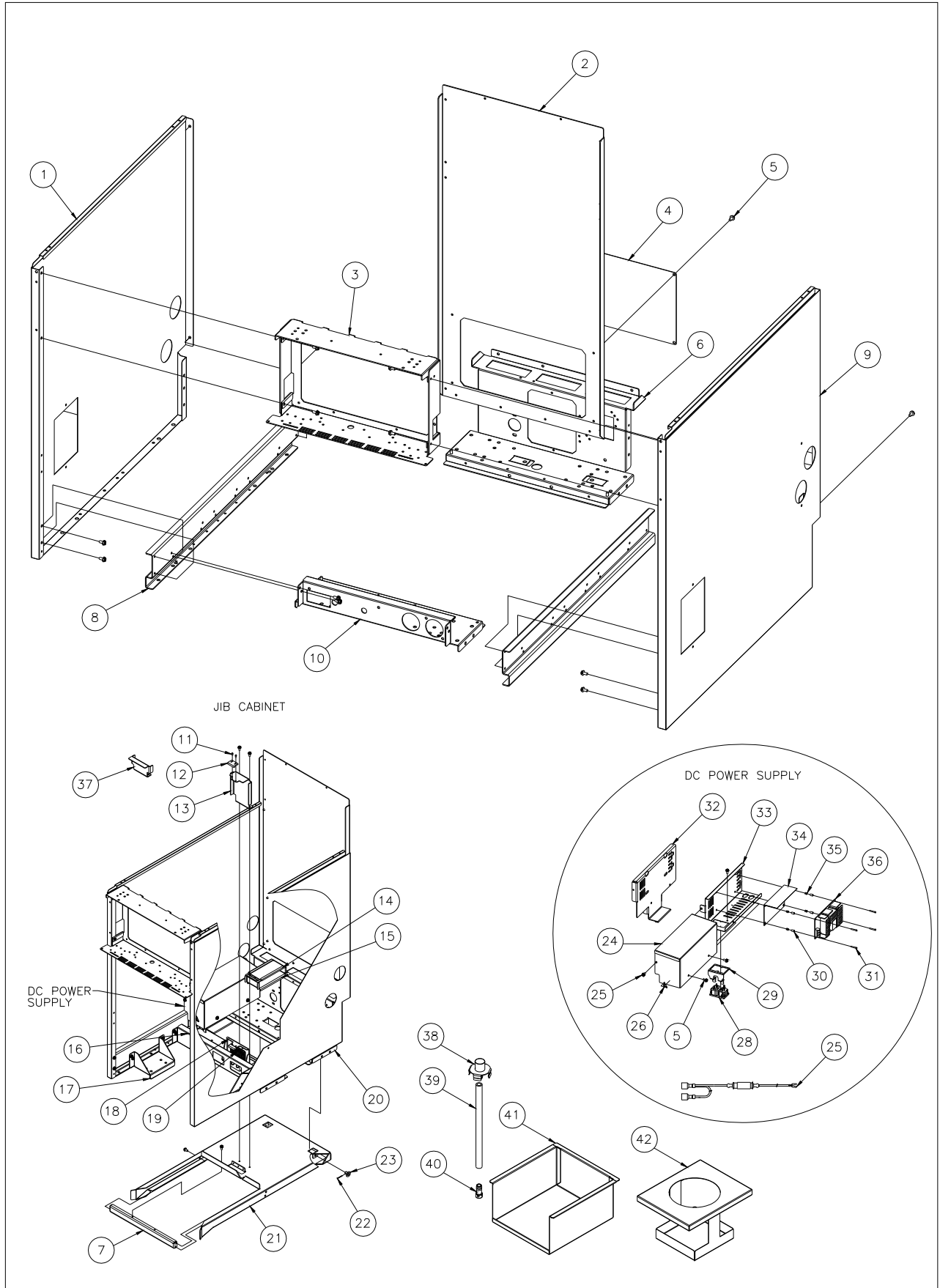

E.) Top Deck & Control Panel Parts List

ITEM #	PART#	PART DESCRIPTION
1	B3638601	FRONT PANEL, HEMMED TOP DECK ASSEMBLY S*LV-1
	B3638602	FRONT PANEL, HEMMED TOP DECK ASSEMBLY S*LV-2
	B3638603	FRONT PANEL, HEMMED TOP DECK ASSEMBLY S*LV-3
	B3638604	FRONT PANEL, HEMMED TOP DECK ASSEMBLY S*LV-4
	B3638605	FRONT PANEL, HEMMED TOP DECK ASSEMBLY S*LV-5
2	A3685002	FRONT PANEL,END CAP LH-RH S*LV
3	A3685702	FRONT PANEL, MIDDLE CAP S*LV
4	60186501	INSULATION, AUTO FILTER BOARD #2
5	A2042301	CONTROL BOX, HEAT SHIELD WRB SGLV
6	A2042201	CONTROL BOX, SSSLV14
7	A3685301	FRONT PANEL, HEAT SHIELD S*LV
8	A3685401	FRONT PANEL, BEZEL MOUNT BRACKT SELV14*
9	60175301	INSULATION, RELAY BOARD S*LV
10	60183201	PCB, AUTO FILTER BOARD #2
	60183202	PCB, AUTO FILTER BOARD #2 DUAL
11	PP11351	SCREW, 4-40 X 3/4 ROUND HEAD SLOTTED
12	A3682801	FRONT PANEL, BRACKET PLC WRB SELV
13	PP10023	SCREW, 10-24 X 3/8 SELF TAP
14	60178101	ASSEMBLY, OLP DRIVER BRD SELV
15	60171801	PCB, ASSEMBLY FILTER CONTROL LOV W/I
16	60175301	INSULN,RELAY BOARD S*LV
17	60178801	INSULN,OIL LEVEL DRIVE BOAR
18	60092101	NUTSERT,4-40 UNO
19	A2043601	CONTROL BOX, COVER SWITCH TANK REFILL FULL
	A2043603	CONTROL BOX, COVER SWITCH TANK REFILL SPLIT
20	A2043501	CONTROL BOX, HOUSING SWITCH TANK REFILL FULL
	A2043503	CONTROL BOX, HOUSING SWITCH TANK REFILL SPLIT
21	A6105601	LABEL, TANK REFILL
22	PP10654	SWITCH, ROCKER SPST W/BK (1-0)
23	B6799601	WIRING, TANK REFILL SWITVH
24	60130401	BUSHING .512 HOLE DIAMETER
25	B6761801	WIRING, I12+ CNTRL TO SOLSTICE
	B6747001	WIRING, RELAY BOARD NO BKUP OPT S

Top Deck & Control Panel Detail

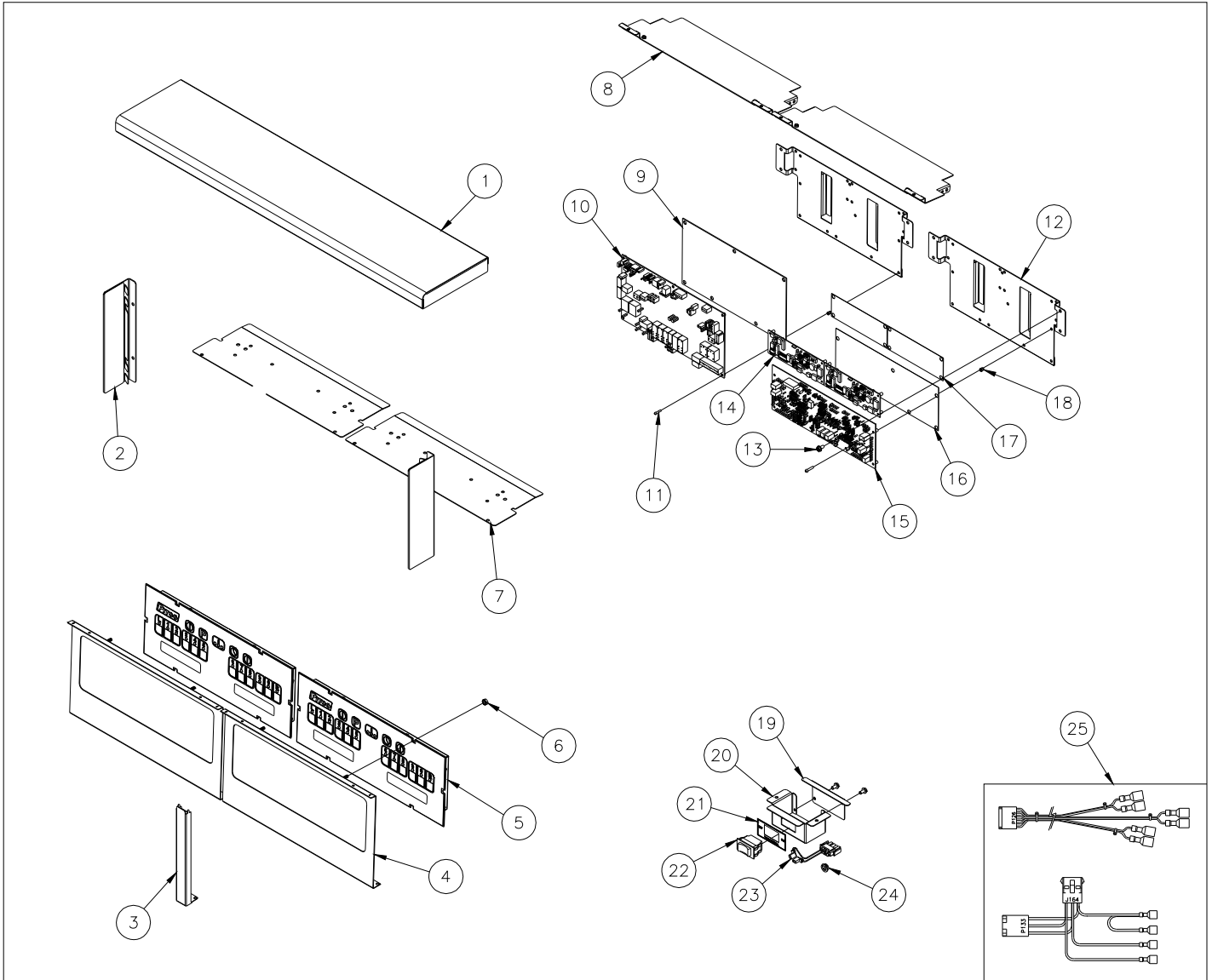

F.) Tank Parts List

ITEM #	PART#	PART DESCRIPTION
1	60179001	PROBE, OIL LEVEL SELV
2	A3372501	TANK, HEAT SHIELD SIDE LH REAR
3	A3372503	TANK, HEAT SHIELD SIDE RH REAR
4	A3034002	TANK BACK, JACKET SELV14
5	B3336501	TANK, WELDMENT SELV14
	B3336502	TANK, WELDMENT SELV14 OLP
	B3337901	TANK, WELDMENT SELV14T
	B3337902	TANK, WELDMENT SELV14T OLP
6	P0154100	CLIP, HITCH PIN
7	B6693201	FILTER, WELDMENT RETURN ACTUATOR MOUNT S*LV
8	60155704	ACTUATOR, LINEAR 2" 24VDC
9	60155704	PIN, CLEVIS .250 X 1.000, .06 PIN CRS
10	B6693201	FILTER, WELDMENT RETURN ACTUATOR MOUNT S*LV
11	60130101	FITTING, ADAPTOR 37.5 FLARE X .5 MPT
12	P7037678	ELBOW, BLACK 90 .500 NPT
13	60186601	VALVE, BALL 1-1/4 FP POWERED
14	A3135102	TANK FRONT, JACKET LOWER
15	A3135202	TANK FRONT, JACKET UPPER
16	A3368401	TANK, HEAT SHIELD SIDE LH
17	A3368403	TANK, HEAT SHIELD SIDE RH
17	B3507301	FLUE, WELDMENT SSHLV14
	B3507201	FLUE, WELDMENT SSHLV14T
18	A2977801	ENTRANCE BOX, MOUNTING PLATE SELV14
19	PP10023	SCREW, 10-24 X 3/8 SELF TAP
20	A3372901	TANK, BRACKET DRAIN VALVE HANDLE FULL SELV14
	A3372903	TANK, BRACKET DRAIN VALVE HANDLE SPLIT SELV14T
21	P0190200	PIN COTTER 1/16 X 3/4 ZN
22	60138702	VALVE, BALL 1-1/4 NON LOCKING
23	B4007801	HANDLE, DRAIN VALVE WELDMENT SELV
24	P0080850	WASHER, FLAT 3/8 .805-.827 OD Z
25	PP10263	SWITCH, PROXIMITY ACTUATOR
26	PP10266	SCR, 4-40 X .250 RDH ZN
27	B5305001	ELEC ASSY, DVI
28	PP10687	SCREW, 6-32 X 313 THRUSS HEAD PHILLIPS ZN
29	A4027601	HANDLE, PLATE DVI SELV14*
30	A4027702	HANDLE, DRAIN VALVE FULL SELV
	A4027704	HANDLE, DRAIN VALVE SPLIT SELV14T

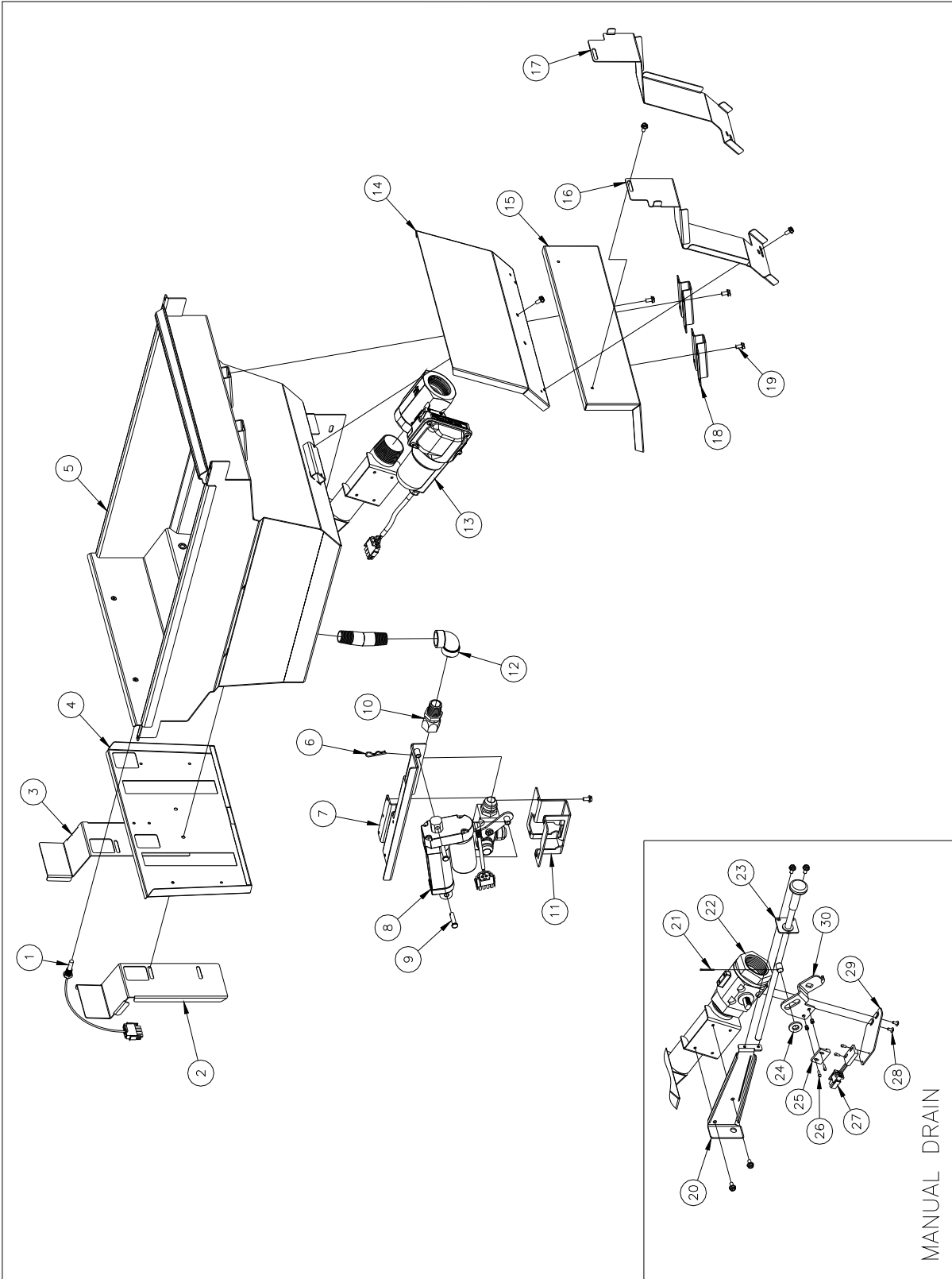

G.) Drain Line Parts list

ITEM #	PART#	PART DESCRIPTION
1	A7022101	FILTER DRAIN SEAL FERRULE
2	A7021701	FILTER, NIPPLE ADAPTER
3	A7022201	FILTER DRAIN FLANGE
4	B6665101	FILTER DRAIN ELBOW
5	60059302	DRAIN LINE GASKET
6	A7022407	FILTER DRAIN LINE TUBE SSHLV14-SSHLV
	A7022411	FILTER, DRAIN LINE TUBE SG14T/SG14
7	B6664703	FILTER, DRAIN LINE DOWN SPOUT S*LV14
8A	60068303	FLUROPOLYMER O-RING, 3" X 3.25 OD (WHITE)
8B	60068302	VITON O-RING (BLACK)
9	PP10177	VINYL SCREW PROTECTION CAP
10	60127702	QUICK RELEASE BAND CLAMP
11	B6666702	FILTER, OUT DRAIN S*LV14T-14T
12	P0080650	WASHER, FLAT 1/4
13	P0113300	SCREW, 1/4 - 20 X 3/8
14	B6674402	FILTER, DRAIN LINE DOWN SPOUT SFSELV
15	B6665501	B-N-B DRAIN LINE
16	P0113300	SCREW, 1/4 - 20 X 3/8
17	PP10668	ACORN NUT, 1/4 - 20
18	A7049201	FILTER, BRACKET BNB DRAIN SUPPORT SELVBNB
19	P0080650	WASHER, FLAT 1/4

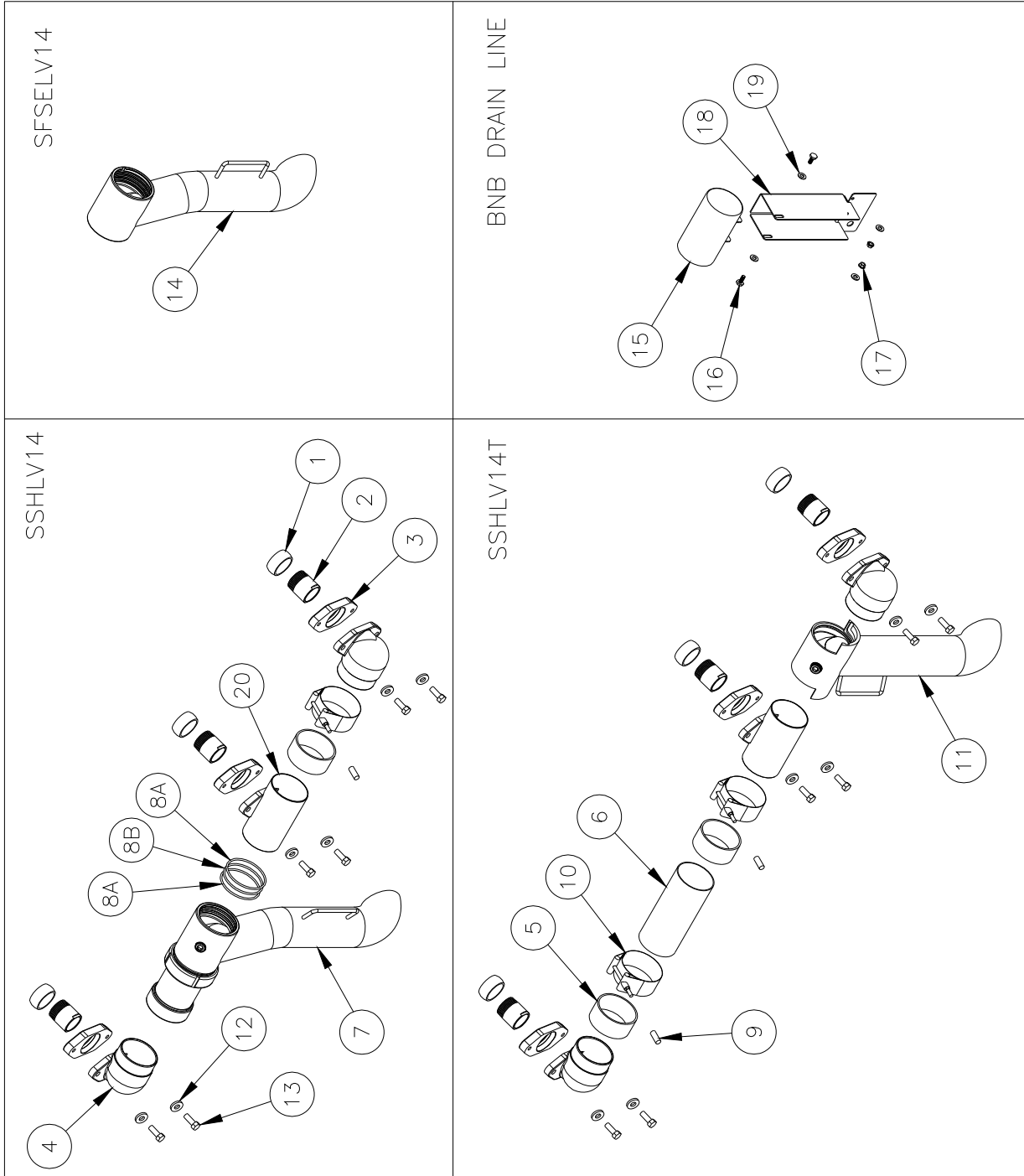

H.) Entrance Box Parts List

ITEM #	PART#	PART DESCRIPTION
1	A2974103	ENTR BOX,SD LH SELV
2	A2974901	ENTR BOX,SELV
3	A2974101	ENTR BOX,SD RH SELV
4	A2977701	ENTR BX,BDY TP
5	A2979401	ENTR BX,WTR DVTR
6	B2919501	ENTR BOX,WLDMT SELV
7	A2974501	ENTR BOX,STRAIN RELIEF BRAC
8	A2973801	ENTR BOX,RWY BDY SELV
9	A2975401	ENTR BOX,STRAIN RELIEF BRAC
10	60140701	RCPT,10A-250V IE320F SCRW I
11	PP10687	SCR,6-32 X 5/16 TH PHILLIPS
12	P5045140	TIE,CABLE 1/16-5/8
13	A2974601	ENTR BOX,VERT RWY COV SELV
14	60178801	INSULATION, OIL LEVEL DRIVE BOARD
15	A2974301	ENTR BOX,RWY FR COV SELV
16	A2974401	ENTR BOX,RWY RR COV SELV
17	A2974001	ENTR BOX,VERT RCY SD SELV
18	PP10023	SCR,10-24 X 3/8 SLF TAP
19	P5045701	FUSE,40A-SLO BLOW
20	PP10698	SCREW, 10-24 X .625 ROUND HEAD PHILLIPS SST
21	P5045792	FUSEBLOCK,3 POST 480V 60A
22	60145301	LUG,GRND ALUM
23	PP10020	LBL,GROUND SYMBOL
24	A2973901	ENTR BOX,PWR BX HSG COV SEL
25	PP10605	FASTENER,TERM BLOCK LBL
26	P6094942	LABEL,MARKING STRIP L1 TO L
	A6043901	LABEL, MARKING L3 AND N
	P6094940	LABEL, MARKING L1 AND L2
27	60072101	SCREW, 10-24 X .375 ROUND HEAD PHILLIPS SST
28	P5047301	BLK,TERM-3 POST ENTRANCE
	P5047302	BLK,TERM-2 POST ENTRANCE
29	A2974701	ENTR BOX,COV SELV
30	60139201	CONTACTOR,3P,50A,690V,IEC
31	A2974201	ENTR BOX,CNTOR PLT SELV
32	60157202	CONTACTOR,DP 3P 50A 600V RE
33	60127201	CAP,TAB .187 SERIES
34	P5045285	JMPR,TERM. BLK. - BARRIER
35	60172201	SNUBBER,24VAC COILS, .25TAB
36	PP10429	XFMR,80VA 120/208/240V TO 2
37	P5045282	BLK,TERM 4POLE BARRIER
38	P6071228	GROMMET,1.703ID X 2.50D X 2
HARNESSES, SEE TABLE B		

Entrance Box Detail

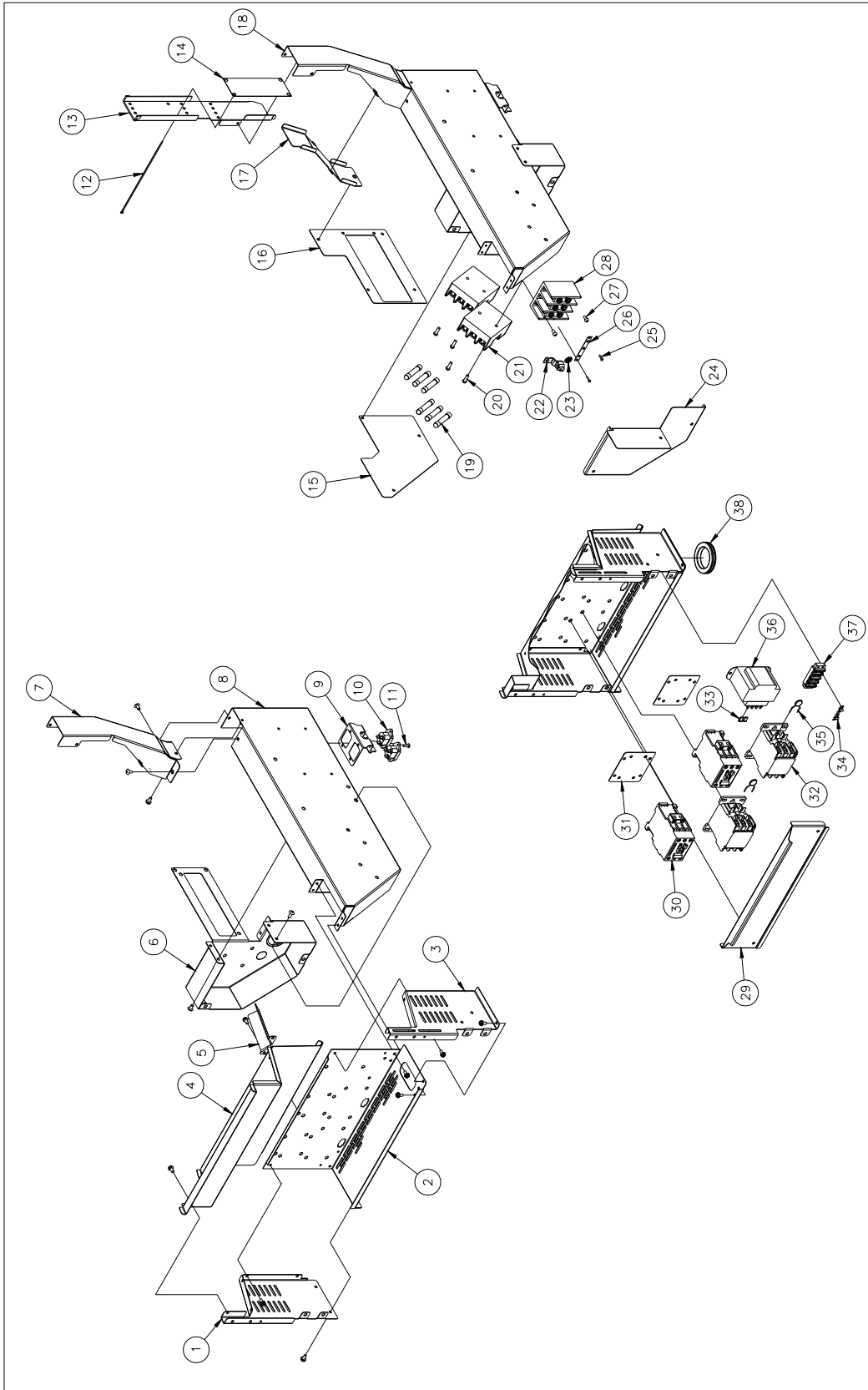

Entrance Box Parts List B

ITEM #	PART#	PART DESCRIPTION
HARNESSES	B6794401	WRG,HV WYE NO FUSE SELV14
	B6795101	WRG,JMPR FILT CNT SWITCH
	B6795301	WRG,CNTRL COMMON KIT SELV
	B6795401	WRG,CNTRL SINGLE SELV
	B6794701	WRG,HV DELTA WITH FUSE SELV
	B6794501	WRG,HV WYE NO FUSE SELV14T
	B6795501	WRG,CNTRL DUAL SELV
	B6794601	WRG,HV DELTA WITH FUSE SELV



This Page Left Intentionally Blank

J.) Full Pivot Box Parts List

ITEM #	PART#	PART DESCRIPTION
1	B2608601	PIVOT BOX, LOWER PANEL WELDMNT SELV14T
2	A2610802-1	PIVOT BOX, BODY SELV14 CTD
3	60054901	BRG, FLG-BRONZE .313ID FOOD
4	B2608302	PIVOT BOX, BRACKET SPRNG MNTG RH S
5	B2608301	PIVOT BOX, BRACKET SPRNG MNTG LH S
6	A2808001	ELEMENT RACK, BOTTOM SELV14
7	A2612002	PIVOT BOX, BRACKET HI LMT
8	A2611302	PIVOT BOX, RTN PRB SEAL FR SEL
9	A2611304	PIVOT BOX, RTN PRB SEAL BACK SEL
10	B5305001	ELEC ASSY, DVI
11	PP10263	SWITCH, PROXIMITY ACTUATOR
12	PP10665	SCREW, 10-24 X 3/8 RDH SS
13	60048009	SCREW, SHLDR 1/4-20X.5X.313DIA
14	60069502	SCREW, 10-24 X 1/2 FH HEX SKT
15	60175401	SCREW, 6-32 X 3/8PH INTLK WSHR
16	60092101	NUTSERT, 4-40 UNC
17	60066801	SCREW, 4-40 X .375 RDH ZN
18	PP10686	SCREW, 6-32 X 1/4 RDH PHILLIPS
19	A4112302	SPLASH BACK, SELV
20	A4114201	SPLASH BACK, AIR DVRTR
21	60132001	TANK, STUD SPLH BACK SCREW ON
22	60125801	SCREW, 10-24 X 3/8 TH SST SLOT
23	60118201	BOLT, HEX FLN HD 1/4-20 X 3/
24		ELEMENTENTS, SEE TABLE B
25	60173501	PROBE, TMTR SELV
26	P5047216	SWITCH, HI LIMIT LCH 37030
27	B2811701	ELEMENT RACK, HANDLE WLDMT SELV14
28	A2611502	PIVOT BOX, ELEMENT SRTP FR SELV14
29	A2611402	PIVOT BOX, ELEMENT SRTP RR SELV14
30	A2611601	PIVOT BOX, BRACKET UPR SPR SELV14
31	B6796501	WIRING, HIGH LIMIT LH
32	A2612202	PIVOT BOX, LCHM CLMP
33	60176801	GASKET, PIVOT BOX SNSR

Full Pivot Box Detail

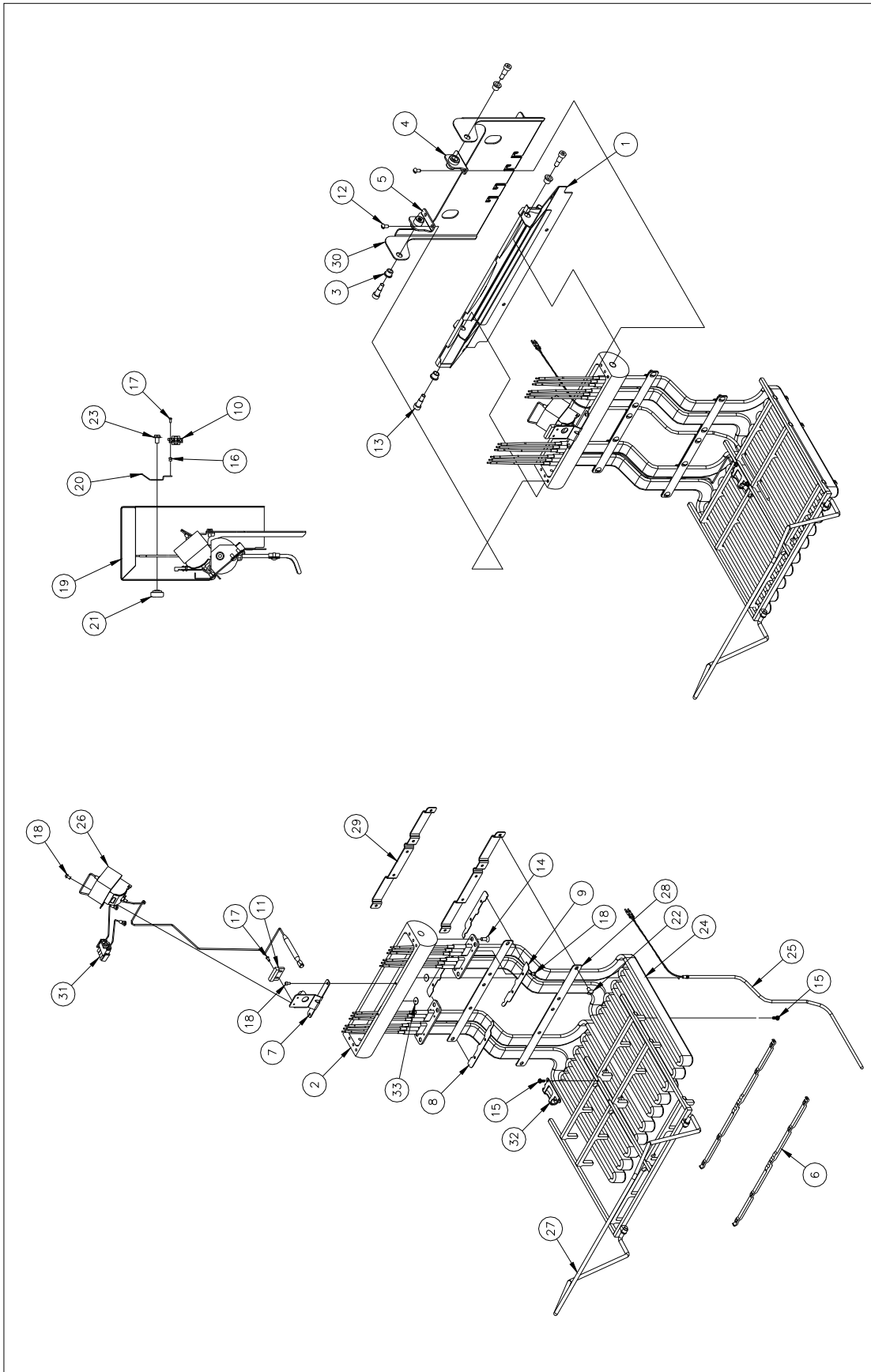

Full Pivot Box Parts List B

ITEM #	PART#	PART DESCRIPTION
14	50007801	ELEMENT, FLAT BAR 7KW 208V
	50007802	ELEMENT, FLAT BAR 7KW 220V
	50007803	ELEMENT, FLAT BAR 7KW 230V
	50007804	ELEMENT, FLAT BAR 7KW 240V
	50007805	ELEMENT, FLAT BAR 7KW 480V
	50007806	ELEMENT, FLAT BAR 8.5KW 208V
	50007807	ELEMENT, FLAT BAR 8.5KW 220V
	50007808	ELEMENT, FLAT BAR 8.5KW 230V
	50007809	ELEMENT, FLAT BAR 8.5KW 240V
	50007810	ELEMENT, FLAT BAR 8.5KW 480V
	50007811	ELEMENT, FLAT BAR 11KW 220V
	50007812	ELEMENT, FLAT BAR 11KW 230V
	50007813	ELEMENT, FLAT BAR 11KW 240V
	50007814	ELEMENT, FLAT BAR 11KW 480V



This Page Left Intentionally Blank

K.) Split Pivot Box Parts List

ITEM #	PART#	PART DESCRIPTION
1	B2608602	PIVOT BOX, LOWER PNL WLDMT SELV114T
2	A2610902-1	PIVOT BOX, BODY SELV14T CTD
3	60054901	BEARING, FLANGE-BRONZE .313ID FOOD
4	B2811702	ELEMENT RACK, HANDLE WELDMENT SELV14T
5	60069502	SCREW,10-24 X 1/2 FH HEX SKT
6	A2611306	PIVOT BOX, RTN PRB SEAL SELV14
7	A2808101	ELEMENT RACK, BOTTOM SELV14T
8	B2608302	PIVOT BOX, BRACKET SPRINGNG MNTG RH S
9	B2608301	PIVOT BOX, BRACKET SPRINGNG MNTG LH S
10	60054902	BRG,FLG-BRONZE .625ID FOOD
11	60048009	SCREW,SHLDR 1/4-20X.5X.313DIA
12	PP10665	SCREW,10-24 X 3/8 RDH S
13	A2612302	PIVOT BOX, BRACKET HI LMT LH
14	60092101	NUTSERT,4-40 UNC
15	PP10263	SW,PROXIMITY ACTUATOR
16	B5305001	ELEC ASSY,DVI
17	60066801	SCREW,4-40 X .375 RDH ZN
18	60173501	PRB,TMTR SELV
19	P5047216	SW,HI LIMIT LCH 37030
20	60175401	SCREW,6-32 X 3/8PH INTLK WSHR
21	PP10686	SCREW,6-32 X 1/4 RDH PHILLIPS
22	A4112302	SPLSH BK,SELV
23	A4114201	SPLSH BK,AIR DVRTR
24	60125801	SCREW,10-24 X 3/8 TH SST SLOT
25	60132001	TK,STUD SPLH BK SCREW ON
26	60118201	BOLT,HEX FLN HD 1/4-20 X 3/
27		ELEMENTENTS, SEE TABLE B
28	A2611404	PIVOT BOX, ELEMENT STRAP RR SELV14
29	A2611504	PIVOT BOX, ELEMENT STRAP FR SELV14
30	A2611701	PIVOT BOX, BRACKET UPR SPRING LH SELV
31	A2611703	PIVOT BOX, BRACKET UPR SPRING RH SELV
32	A2611802	PIVOT BOX, SPRING BRKT SPRINGT LH SEL
33	A2611804	PIVOT BOX, SPRING BRKT SPRINGT RH SEL
34	PP10023	SCREW, 10-24 X 3/8 SLF TAP
35	B6796501	WIRING, HIGH LIMIT LH
36	B6796502	WIRING, HIGH LIMIT RH
37	A2612402	PIVOT BOX,LCHM CLMP SPLT
38	A2612304	PIVOT BOX, BRACKET HI LMT RH
39	60176801	GASKET,PIVOT BOX SNSR

Split Pivot Box Detail

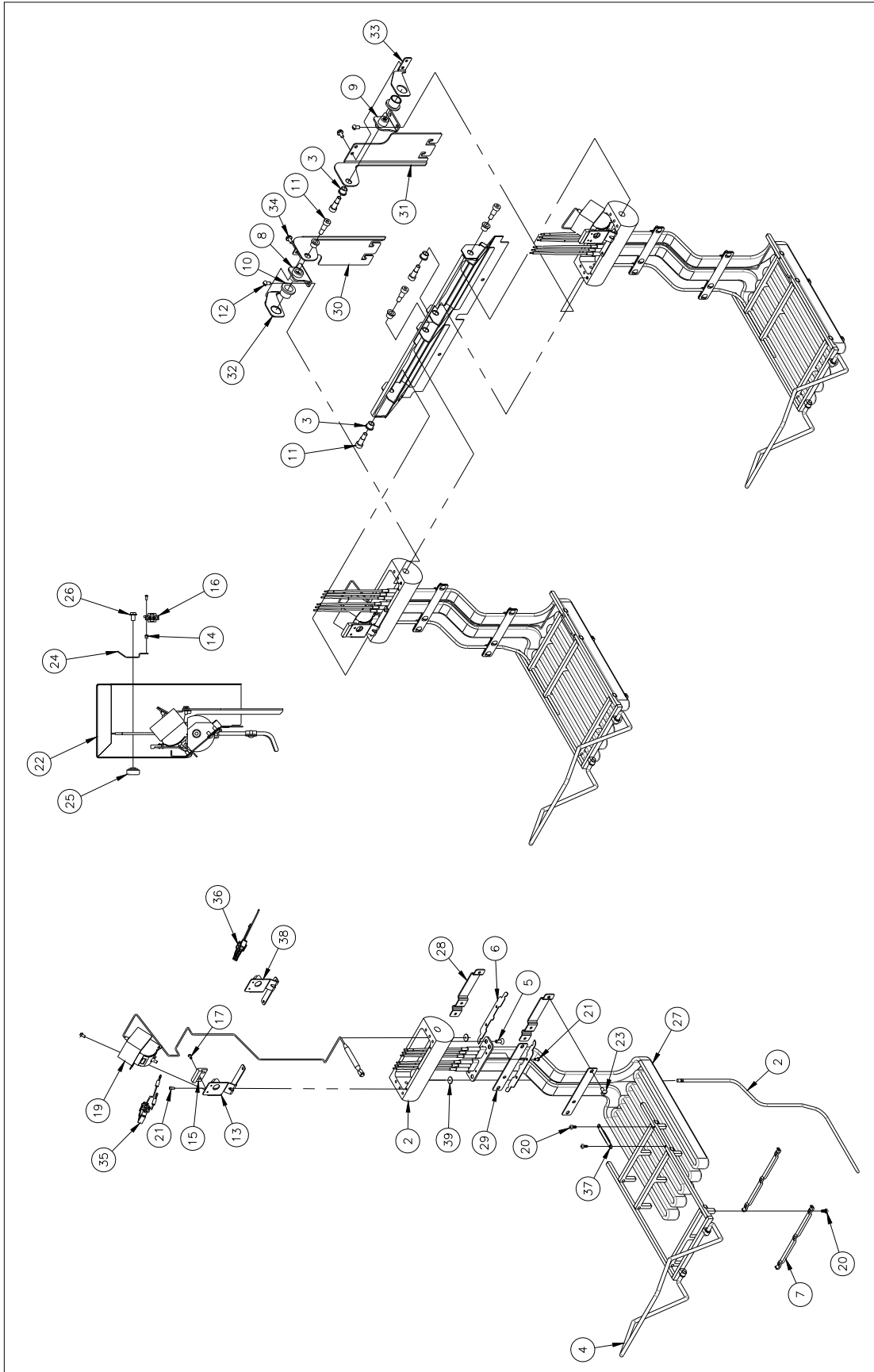

Split Pivot Box Parts List B

ITEM #	PART#	PART DESCRIPTION
27	50007801	ELEMENT, FLAT BAR 7KW 208V
	50007802	ELEMENT, FLAT BAR 7KW 220V
	50007803	ELEMENT, FLAT BAR 7KW 230V
	50007804	ELEMENT, FLAT BAR 7KW 240V
	50007805	ELEMENT, FLAT BAR 7KW 480V
	50007806	ELEMENT, FLAT BAR 8.5KW 208V
	50007807	ELEMENT, FLAT BAR 8.5KW 220V
	50007808	ELEMENT, FLAT BAR 8.5KW 230V
	50007809	ELEMENT, FLAT BAR 8.5KW 240V
	50007810	ELEMENT, FLAT BAR 8.5KW 480V
	50007811	ELEMENT, FLAT BAR 11KW 220V
	50007812	ELEMENT, FLAT BAR 11KW 230V
	50007813	ELEMENT, FLAT BAR 11KW 240V
	50007814	ELEMENT, FLAT BAR 11KW 480V



This Page Left Intentionally Blank

L.) Basket Lift Assembly Parts List

ITEM #	PART#	PART DESCRIPTION
1	A5624302	BASKET LIFT MOUNT SIDE LEFT SELV14
2	A5618302	BASKET LIFT MOUNT BOTTOM SG
3	A5624304	BASKET LIFT MOUNT SIDE RIGHT SELV14
4	PP10023	SCREW 10-24 X 3/8 SELF TAPPING
5	B5609401	BASKET LIFT, PADDLE SELV14 LH
6	B5606021	BASKET LIFT, PADDLE SELV14 RH
7	A5618502	BASKET LIFT DRIP SHIELD SG
8	PP10668	NUT ACORN W/CENTERLOCK 1/4-20
9	A5617902	BASKET LIFT HANGER SUPPORT AXLE SG
10	A5617801	BASKET LIFT HANGER SUPPORT WHEEL SG
11	A5624402	BASKET LIFT, HANGER SUPPORT SELV14*
12 NOT SHOWN	B5604409	BASKET LIFT HANGER SUPPORT ASSY SSHLV* (INCLUDES 8-11)
13 NOT SHOWN (INCLUDES ALL ITEMS)	B5604512	BASKET LIFT HANGER AND MOUNTING KIT SSHLV14 (INCLUDES 1-11)
	B5604513	BASKET LIFT HANGER AND MOUNTING KIT SSHLV14T (INCLUDES 1-11)

Basket Lift Assembly Detail

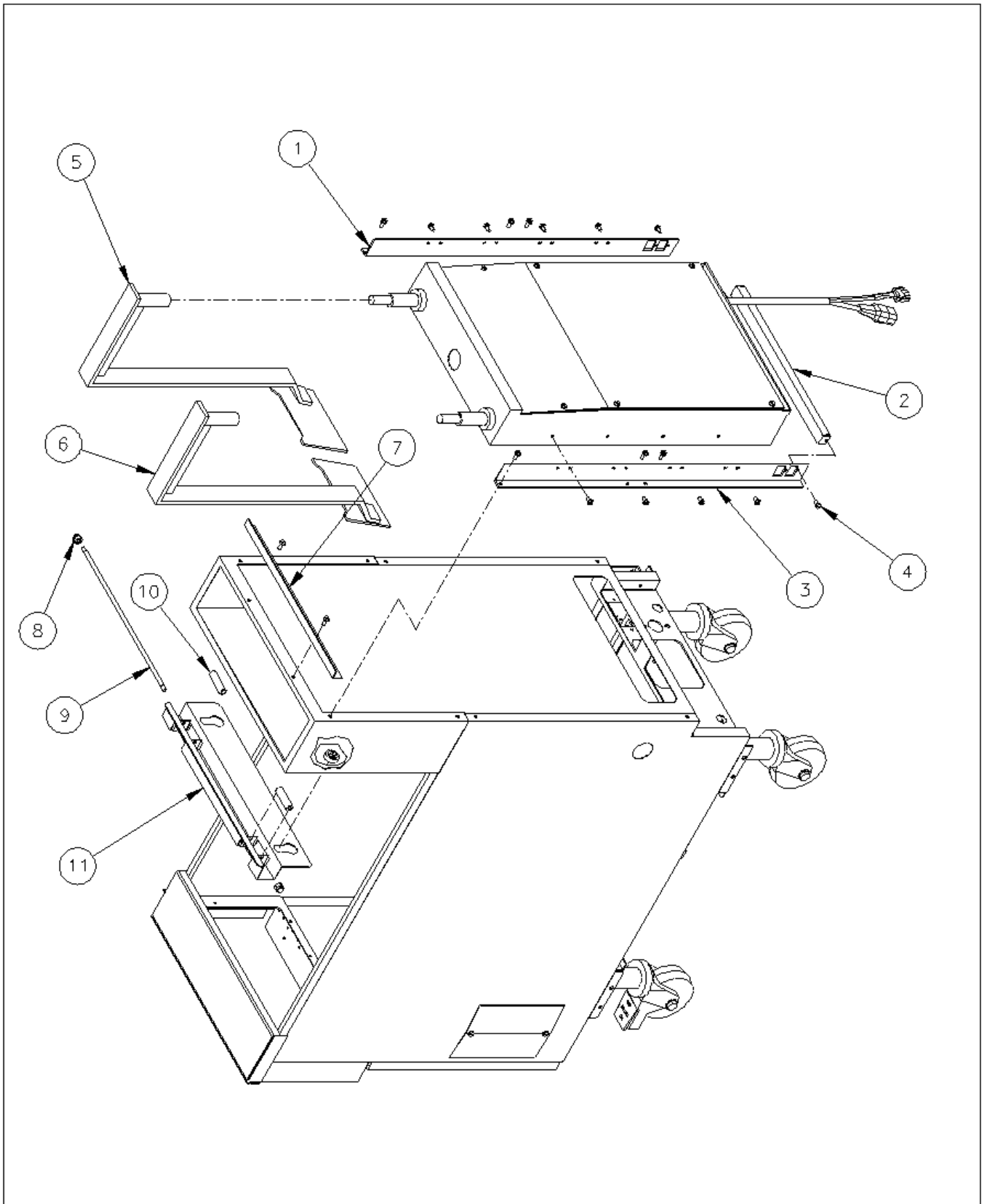

M.) Basket Lift Components Parts List

ITEM #	PART #	PART DESCRIPTION
1	B5605601	BASKET LIFT BOX ACTUATOR MODULAR WELDMENT
2	A5619002	BASKET LIFT BOX COVER ACTUATOR MODULAR
3	60134001	CONTROL BASKET LIFT DRIVER BOARD
4	60134301	ACTUATOR 25 3.3-9.4 24VDC 1IPS LEFT-HAND
5	60134302	ACTUATOR 25 3.3-9.4 24VDC 1IPS RIGHT-HAND
6	PP10429-M	TRANSFORMER 80VA 120/208/240V TO 24V
7	A2958102	ENTRANCE BOX SWITCH COVER 120V
	A2958104	ENTRANCE BOX SWITCH COVER 208V
	A2958106	ENTRANCE BOX SWITCH COVER 220/240V
8	B5308901	WIRING BASKET LIFT LIMIT SWITCH ACTUATOR
9	B6744901	WIRING VOLTAGE SELECT 120/208/220-240V
10	B6748901	WIRING HARNESS BASKET LIFT (SG14T)
11	B6779001	WIRING BASKET LIFT MAIN ACTUATOR
12	B6779101	WIRING BASKET LIFT TRANSFORMER ACTUATOR
13	60136901	CLAMP BASKET LIFT LIMIT SWITCH
14	P6071071	CLAMP WIRE 3/8 NYLON
15	PP10673	WASHER LOCK 1/4 SST SPLIT
16	N/A	WASHER FLAT 1/4 SST
17	N/A	HOLE PLUG KEYSTONE #7610 OR EQUIVALENT
18	N/A	SCREW 6-32 X 3/4 PHH PNH SST W/LK WASHER
19	P0075400	SCREW 10-24 X 1/2 SELF TAPPING
20	PP10693	SCREW 10-24 X 3/8 PHH TRH ZN
21	N/A	SCREW 10-24 X 3/8 IND T HEX W/EXT WASHER
22	N/A	SOCKET HEAD CAP SCREW 1/4-20 X 1-1/2 SST
23 NOT SHOWN (INCLUDES ALL ITEMS)	B5604601-C	BASKET LIFT ACTUATOR BOX ALL VOLTAGES (NOT SHOWN)

Basket Lift Components Detail

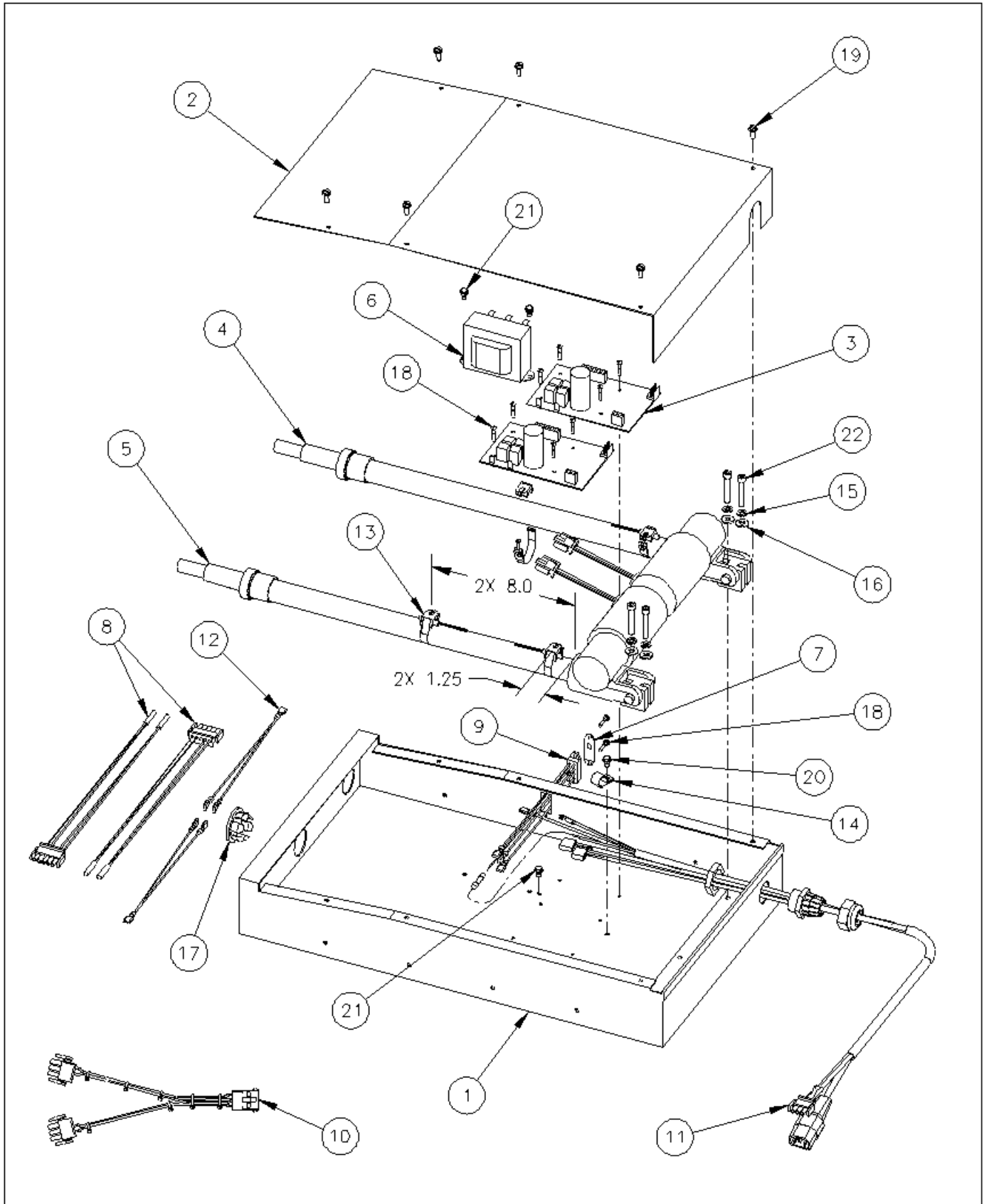



<p>In the event of problems with or questions about your order, please contact the Pitco Frialator factory at</p> <p>(603) 225-6684 World Wide www.pitco.com</p>	<p>In the event of problems with or questions about your equipment, please contact the Pitco Frialator Authorized Service and Parts representative (ASAP) covering your area, or contact Pitco at the numbers listed to the left.</p>
---	---

MAILING ADDRESS – P.O. BOX 501, CONCORD, NH 03302-0501
SHIPPING ADDRESS – 10 FERRY ST., CONCORD, NH 03301