

ITEM	QTY	PART #	DESCRIPTION
1	1	39464	DIVIDER FOR 19 x 24.75 PRODUCE SOAK, FIVE GUYS
2	2	34116	FLOW GUIDE, PRODUCE SOAK
3	2	36289	RIB ASSEMBLY, FRONT, RADIUS INSERTS, PRODUCE SOAK
4	2	36322	RIB ASSEMBLY, REAR, RADIUS INSERTS, PRODUCE SOAK
5	1	37748	AWI WAVE GUIDE, PRODUCE, 18" (2-BAY)

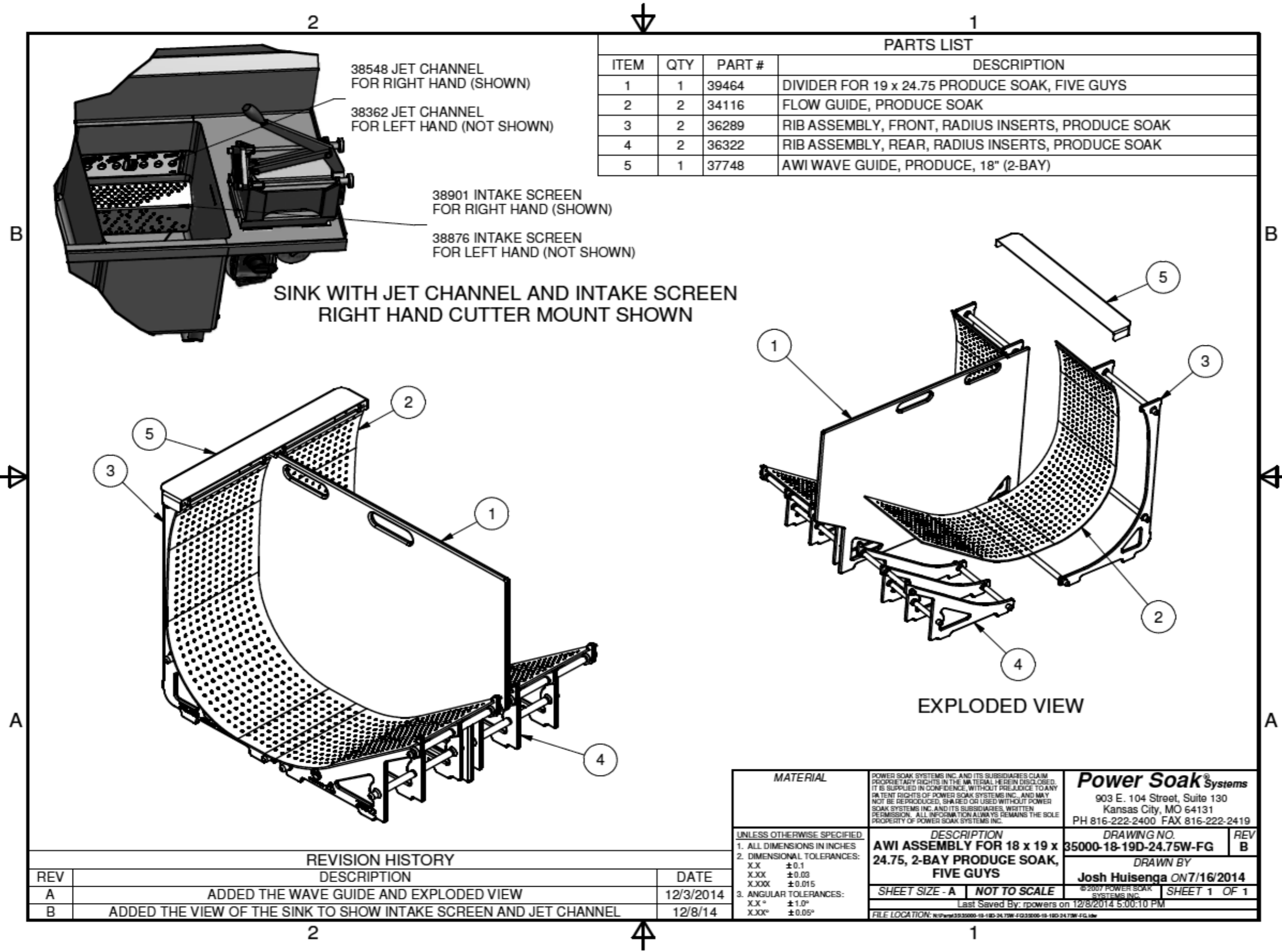

REVISION HISTORY		
REV	DESCRIPTION	DATE
A	ADDED THE WAVE GUIDE AND EXPLODED VIEW	12/3/2014
B	ADDED THE VIEW OF THE SINK TO SHOW INTAKE SCREEN AND JET CHANNEL	12/8/14

MATERIAL	POWER SOAK SYSTEMS INC. AND ITS SUBSIDIARIES CLAIM PROPRIETARY RIGHTS IN THE MATERIAL HEREIN DISCLOSED. IT IS SUPPLIED IN CONFIDENCE, WITHOUT PREJUDICE TO ANY PATENT RIGHTS OF POWER SOAK SYSTEMS INC. AND MAY NOT BE REPRODUCED, SHARED OR USED WITHOUT POWER SOAK SYSTEMS INC. AND ITS SUBSIDIARIES WRITTEN PERMISSION. ALL INFORMATION ALWAYS REMAINS THE SOLE PROPERTY OF POWER SOAK SYSTEMS INC.	Power Soak Systems 903 E. 104 Street, Suite 130 Kansas City, MO 64131 PH 816-222-2400 FAX 816-222-2419
UNLESS OTHERWISE SPECIFIED: 1. ALL DIMENSIONS IN INCHES 2. DIMENSIONAL TOLERANCES: X.X ±0.1 X.XX ±0.03 X.XXX ±0.015 3. ANGULAR TOLERANCES: X.X° ±1.0° X.XX° ±0.05°	DESCRIPTION AWI ASSEMBLY FOR 18 x 19 x 24.75, 2-BAY PRODUCE SOAK, FIVE GUYS	DRAWING NO. 35000-18-19D-24.75W-FG DRAWN BY Josh Huisenga ON7/16/2014 © 2007 POWER SOAK SYSTEMS INC. SHEET 1 OF 1
SHEET SIZE - A NOT TO SCALE		REV B
Last Saved By: rpowers on 12/8/2014 5:00:10 PM FILE LOCATION: N:\Part\3535000-18-19D-24.75W-FG\35000-18-19D-24.75W-FG.dwg		

PARTS LIST

ITEM	QTY	PART #	DESCRIPTION
1	1	38891-PRT	WELDMNT, ATTACHMENT, POTATO CUTTER, WIDE KEYHOLE MOUNT
2	1	38892	LATCH, POTATO CUTTER, WIDE KEY HOLE MOUNT
3	2	29682	NYLOCK NUT, 5/16-18, STN STL
4	2	39120	PAD, POTATO CUTTER MOUNT, TWO HOLE
5	4	33189	1/4-20 UNC X 3/4" HEX HEAD BOLTS
6	4	17189	1/4" FLAT WASHER
7	1	32119	LOCTITE 242 (Blue) 0.5ml PACK (Not Shown)

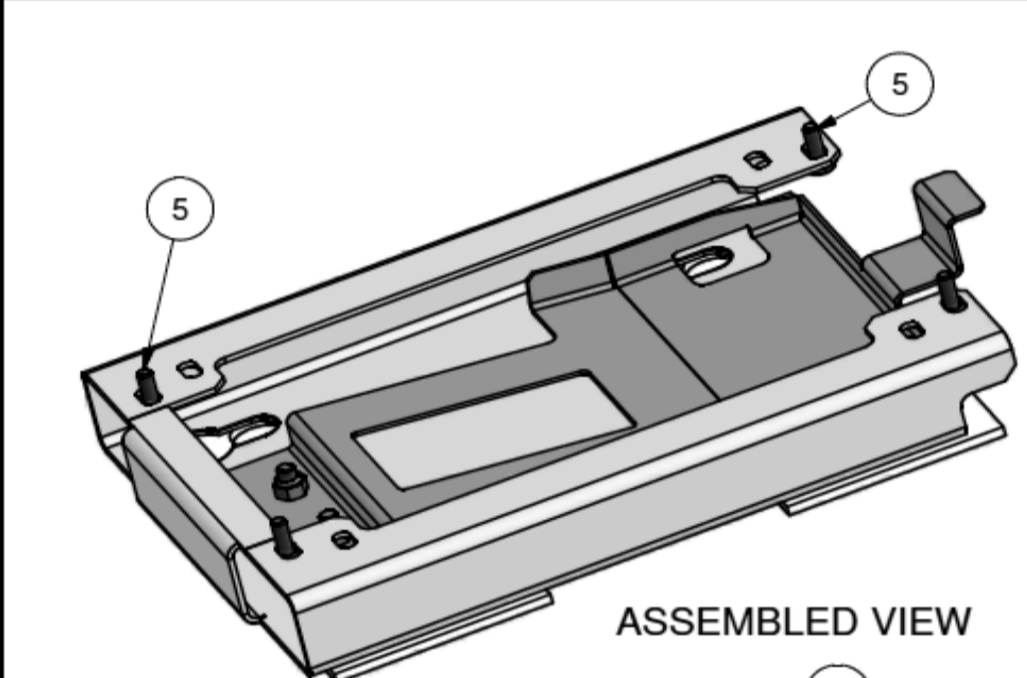

ASSEMBLED VIEW

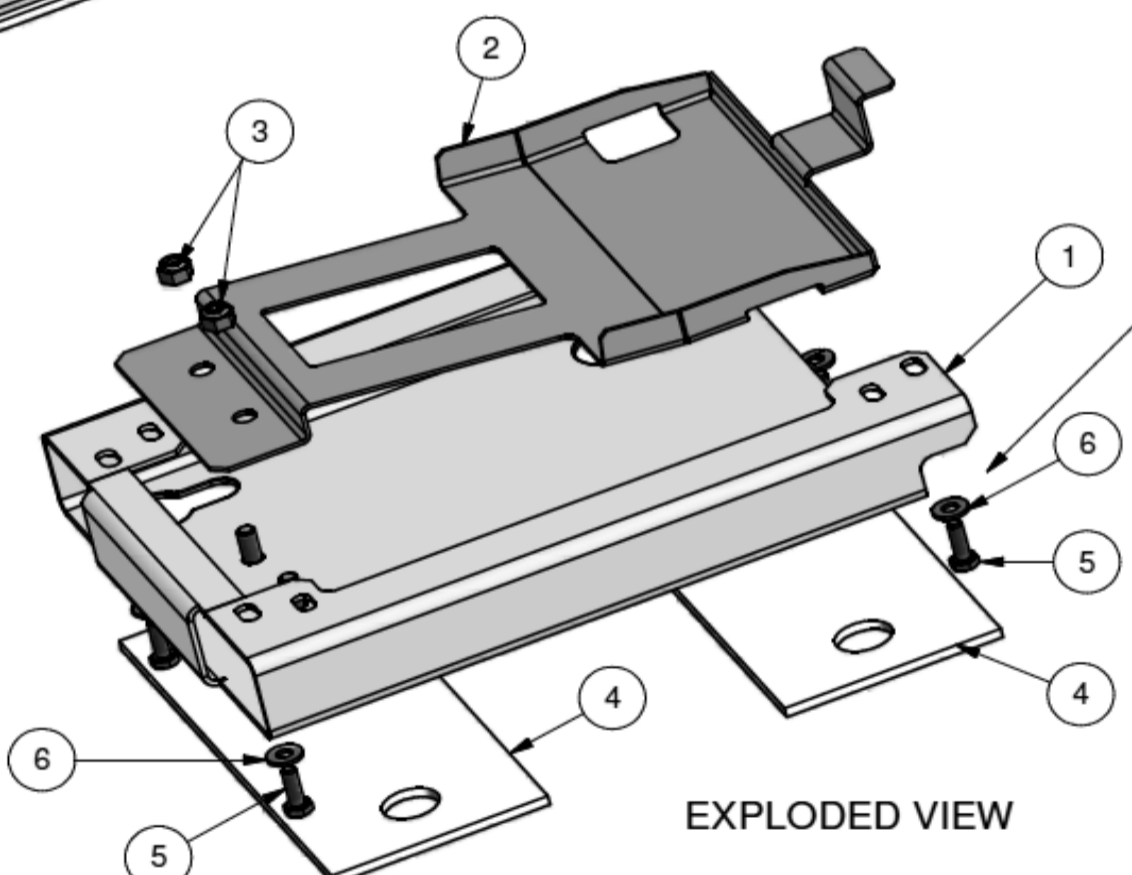

EXPLODED VIEW

PARTS LIST

ITEM	QTY	PART #	DESCRIPTION
1	1	38891	WELDMNT, ATTACHMENT, POTATO CUTTER, WIDE KEYHOLE MOUNT
2	1	38892	LATCH, POTATO CUTTER, WIDE KEY HOLE MOUNT
3	2	29682	NYLOCK NUT, 5/16-18, STN STL
4	2	39120	PAD, POTATO CUTTER MOUNT, TWO HOLE
5	4	33189	1/4-20 UNC X 3/4" HEX HEAD BOLTS
6	4	17189	1/4" FLAT WASHER
7	1	32119	LOCTITE 242 (Blue) 0.5ml PACK (Not Shown)

NOTES:

1. INSTALL THE LATCH BRACKET AND SECURE IT IN POSITION WITH THE NUTS.
2. PLACE THE LOCTITE, 1/4-20 UNC X 3/4" HEX HEAD BOLTS AND 1/4" FLAT WASHERS IN A BAG AND TAPE THE BAG TO THE SHEET METAL.
3. LAY THE TWO HOLE PADS INSIDE THE WELDMNT FOR SHIPPING.

REVISION HISTORY		
REV	DESCRIPTION	DATE
A	ADDED LOCTITE TO MATERIALS LIST AND NOTE 2	11/12/2014
B	ADDED BALLON 7 TO DRAWING	

POWER SOAK SYSTEMS INC. AND ITS SUBSIDIARIES CLAIM PROPRIETARY RIGHTS IN THE MATERIAL HEREIN DISCLOSED. IT IS SUPPLIED IN CONFIDENCE, WITHOUT PREJUDICE TO ANY PATENT RIGHTS OF POWER SOAK SYSTEMS INC. AND MAY NOT BE REPRODUCED, SHARED OR USED WITHOUT POWER SOAK SYSTEMS INC. AND ITS SUBSIDIARIES WRITTEN PERMISSION. ALL INFORMATION ALWAYS REMAINS THE SOLE PROPERTY OF POWER SOAK SYSTEMS INC.

Power Soak Systems
903 E. 104 Street, Suite 130
Kansas City, MO 64131
PH 816-222-2400 FAX 816-222-2419

DESCRIPTION POTATO CUTTER MOUNT ASSEMBLY	DRAWING NO. 39121	REV B
DRAWN BY R Powers ON 9/8/2014		
SHEET SIZE - A NOT TO SCALE		SHEET 1 OF 1

Last Saved By: Mike Licata on 4/13/2015 2:52:59 PM
FILE LOCATION: H:\2014\39121\39121.dwg

PARTS LIST

ITEM	QTY	PART #	DESCRIPTION
1	1	27047	INTAKE GASKET
2	1	27132	GASKET, DISCHARGE MANIFOLD FLANGE
3	12	29682	NYLOCK NUT, 5/16-18, STN STL
4	4	31892	Hex Cap Screw, 5/16-18 x 1-1/4, 18-8 SS
5	1	38362	JET CHANNEL, PRODUCE SOAK, 2-BAY, MOLDED, LH
6	1	38650	VOLUTE, FLUSHING, ASSEMBLY, LH
7	1	38876	INTAKE SCREEN, PRODUCE SOAK, 2-BAY, LH
8	1	38999	PRODUCE SOAK WASH TANK WELDMENT, 2-BAY, LH

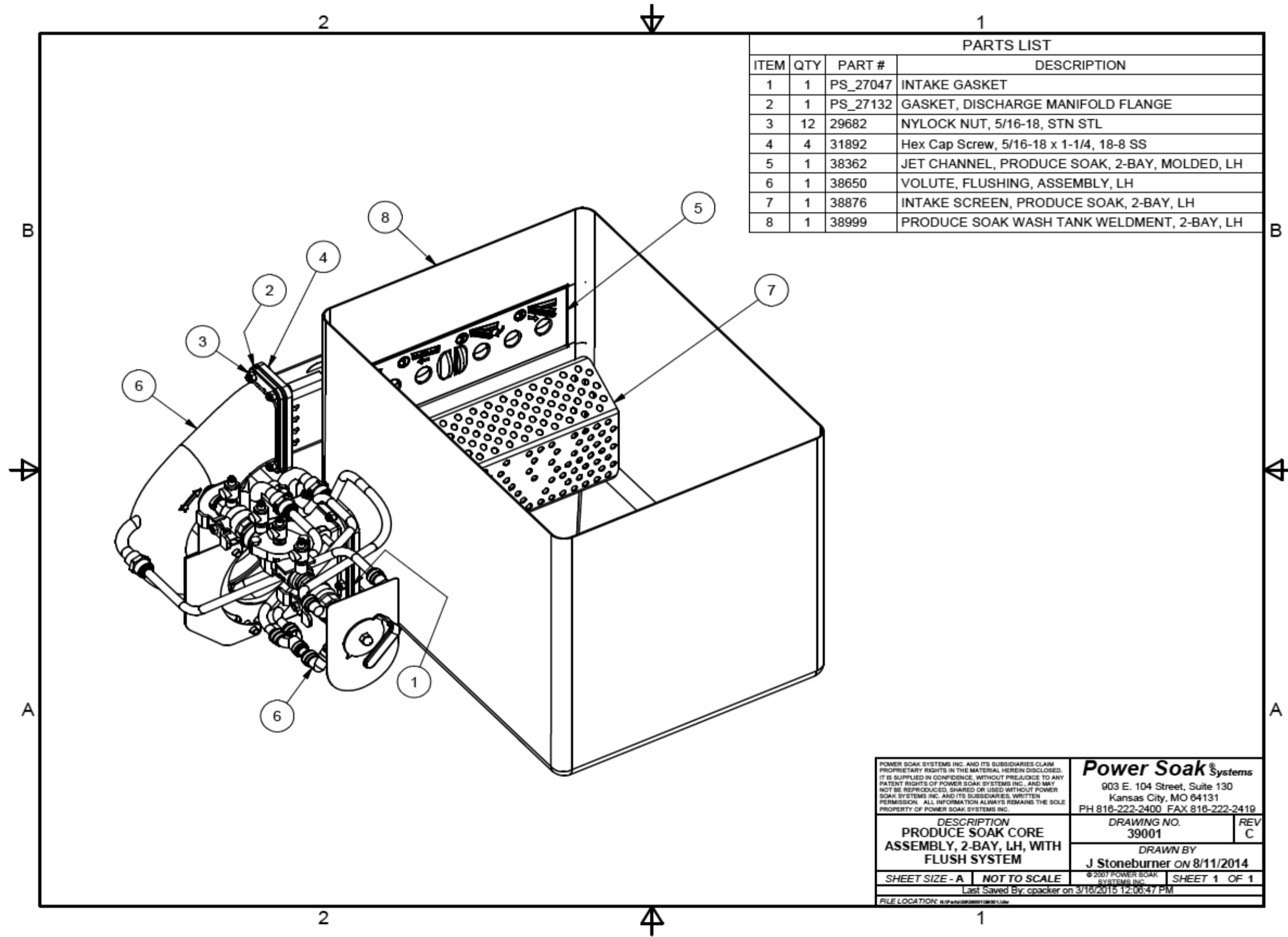

PARTS LIST			
ITEM	QTY	PART #	DESCRIPTION
1	1	PS_27047	INTAKE GASKET
2	1	PS_27132	GASKET, DISCHARGE MANIFOLD FLANGE
3	12	29682	NYLOCK NUT, 5/16-18, STN STL
4	4	31892	Hex Cap Screw, 5/16-18 x 1-1/4, 18-8 SS
5	1	38362	JET CHANNEL, PRODUCE SOAK, 2-BAY, MOLDED, LH
6	1	38650	VOLUTE, FLUSHING, ASSEMBLY, LH
7	1	38876	INTAKE SCREEN, PRODUCE SOAK, 2-BAY, LH
8	1	38999	PRODUCE SOAK WASH TANK WELDMENT, 2-BAY, LH

POWER SOAK SYSTEMS INC. AND ITS SUBSIDIARIES CLAIM PROPRIETARY RIGHTS IN THE MATERIAL HEREIN DISCLOSED. IT IS SUPPLIED IN CONFIDENCE, WITHOUT PREJUDICE TO ANY PATENT RIGHTS OF POWER SOAK SYSTEMS INC. AND MAY NOT BE REPRODUCED, SHARED OR USED WITHOUT POWER SOAK SYSTEMS INC. AND ITS SUBSIDIARIES' WRITTEN PERMISSION. ALL INFORMATION ALWAYS REMAINS THE SOLE PROPERTY OF POWER SOAK SYSTEMS INC.

Power Soak Systems
 903 E. 104 Street, Suite 130
 Kansas City, MO 64131
 PH 816-222-2400 FAX 816-222-2419

DESCRIPTION PRODUCE SOAK CORE ASSEMBLY, 2-BAY, LH, WITH FLUSH SYSTEM	DRAWING NO. 39001	REV C
DRAWN BY J Stoneburner ON 8/11/2014		
SHEET SIZE - A	NOT TO SCALE	SHEET 1 OF 1

© 2007 POWER SOAK SYSTEMS INC.
 Last Saved By: cpacker on 3/16/2015 12:08:47 PM
 FILE LOCATION: \\PFS\PS\39001\39001.dwg

PARTS LIST

Item	QTY	PART #	DESCRIPTION
1	1	39070	PRODUCE SOAK WASH TANK WELDMENT, 2-BAY, RH
2	1	38651	VOLUTE, FLUSHING, ASSEMBLY, RH
3	1	27074	GASKET INTAKE NATURAL PS-200
4	1	27132	GASKET MANIFOLD NATURAL PS-2xx
5	2	29682	NYLOCK NUT, 5/16-18, STN STL
6	4	31892	Hex Cap Screw, 5/16-18 x 1-1/4, 18-8 SS
7	1	38548	JET CHANNEL, PRODUCE SOAK, 2-BAY, RH, MOLDED
8	1	38901	INTAKE SCREEN, PRODUCE SOAK, 2-BAY, RH

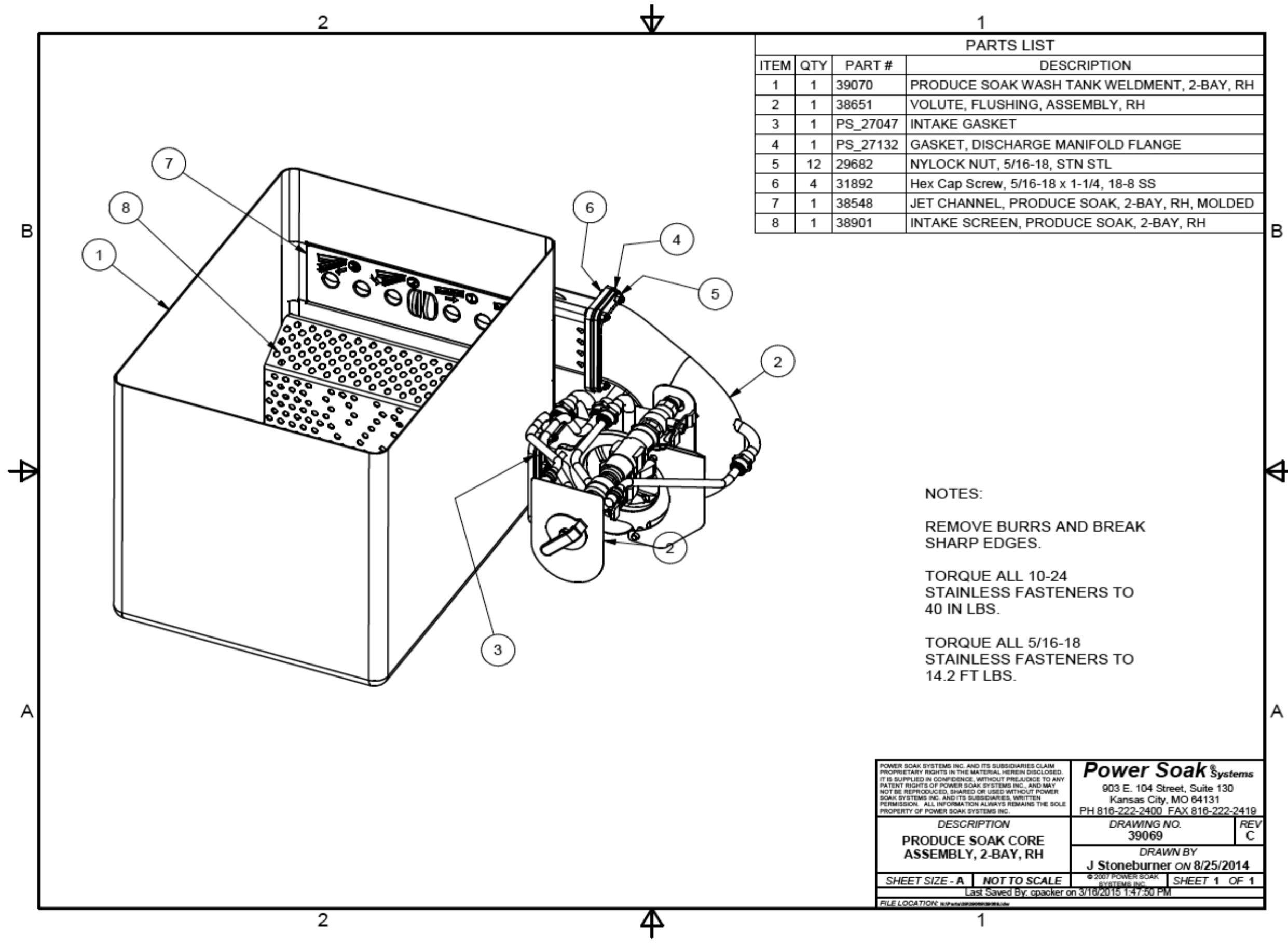

PARTS LIST			
ITEM	QTY	PART #	DESCRIPTION
1	1	39070	PRODUCE SOAK WASH TANK WELDMENT, 2-BAY, RH
2	1	38651	VOLUTE, FLUSHING, ASSEMBLY, RH
3	1	PS_27047	INTAKE GASKET
4	1	PS_27132	GASKET, DISCHARGE MANIFOLD FLANGE
5	12	29682	NYLOCK NUT, 5/16-18, STN STL
6	4	31892	Hex Cap Screw, 5/16-18 x 1-1/4, 18-8 SS
7	1	38548	JET CHANNEL, PRODUCE SOAK, 2-BAY, RH, MOLDED
8	1	38901	INTAKE SCREEN, PRODUCE SOAK, 2-BAY, RH

NOTES:

REMOVE BURRS AND BREAK SHARP EDGES.

TORQUE ALL 10-24 STAINLESS FASTENERS TO 40 IN LBS.

TORQUE ALL 5/16-18 STAINLESS FASTENERS TO 14.2 FT LBS.

<small>POWER SOAK SYSTEMS INC. AND ITS SUBSIDIARIES CLAIM PROPRIETARY RIGHTS IN THE MATERIAL HEREIN DISCLOSED. IT IS SUPPLIED IN CONFIDENCE, WITHOUT PREJUDICE TO ANY PATENT RIGHTS OF POWER SOAK SYSTEMS INC. AND MAY NOT BE REPRODUCED, SHARED OR USED WITHOUT POWER SOAK SYSTEMS INC. AND ITS SUBSIDIARIES WRITTEN PERMISSION. ALL INFORMATION ALWAYS REMAINS THE SOLE PROPERTY OF POWER SOAK SYSTEMS INC.</small>		Power Soak Systems 903 E. 104 Street, Suite 130 Kansas City, MO 64131 PH 816-222-2400 FAX 816-222-2419	
DESCRIPTION PRODUCE SOAK CORE ASSEMBLY, 2-BAY, RH		DRAWING NO. 39069	REV C
SHEET SIZE - A NOT TO SCALE		DRAWN BY J Stoneburner ON 8/25/2014	
© 2007 POWER SOAK SYSTEMS INC.		SHEET 1 OF 1	
<small>FILE LOCATION: \\P:\na\39069\39069.dwg Last Saved By: cpacker on 3/16/2015 1:47:50 PM</small>			

PARTS LIST

ITEM	QTY	PART #	DESCRIPTION
1	6	27484	WASHER, 5/16
2	8	29682	NYLOCK NUT, 5/16-18, STN STL
3	4	32561	NUT, 1/2-13, NYLOCK, 18-8 SS
4	4	32562	WASHER, FLAT, 1/2 ID x 1 OD x 1/16 T, 18-8 SS
5	4	33189	Hex Cap Screw, 1/4-20 UNC - 0.75, 18-8 S/S
6	6	38755	STUD, SHORT CYCLE, 5/16-18 X 5/8, 302HQ SS
7	1	38891-PRT	WELDMNT, ATTACHMENT, POTATO CUTTER, WIDE KEYHOLE MOUNT
8	1	38892	LATCH, POTATO CUTTER, WIDE KEY HOLE MOUNT
9	4	38894	SHOULDER STUD, POTATO CUTTER, KEY HOLE MOUNT
10	4	38918	O-RING, 9/16 ID X 11/16 OD X 1/16 THICK, SIZE No -015
11	1	39099	WELDMNT, POTATO SLICER SUPPORT, REAR, LH MACHINE
12	1	39101	WELDMNT, POTATO CUTTER SUPPORT BRACKET, FRONT, LH UNIT
13	2	39120	PAD, POTATO CUTTER MOUNT, TWO HOLE

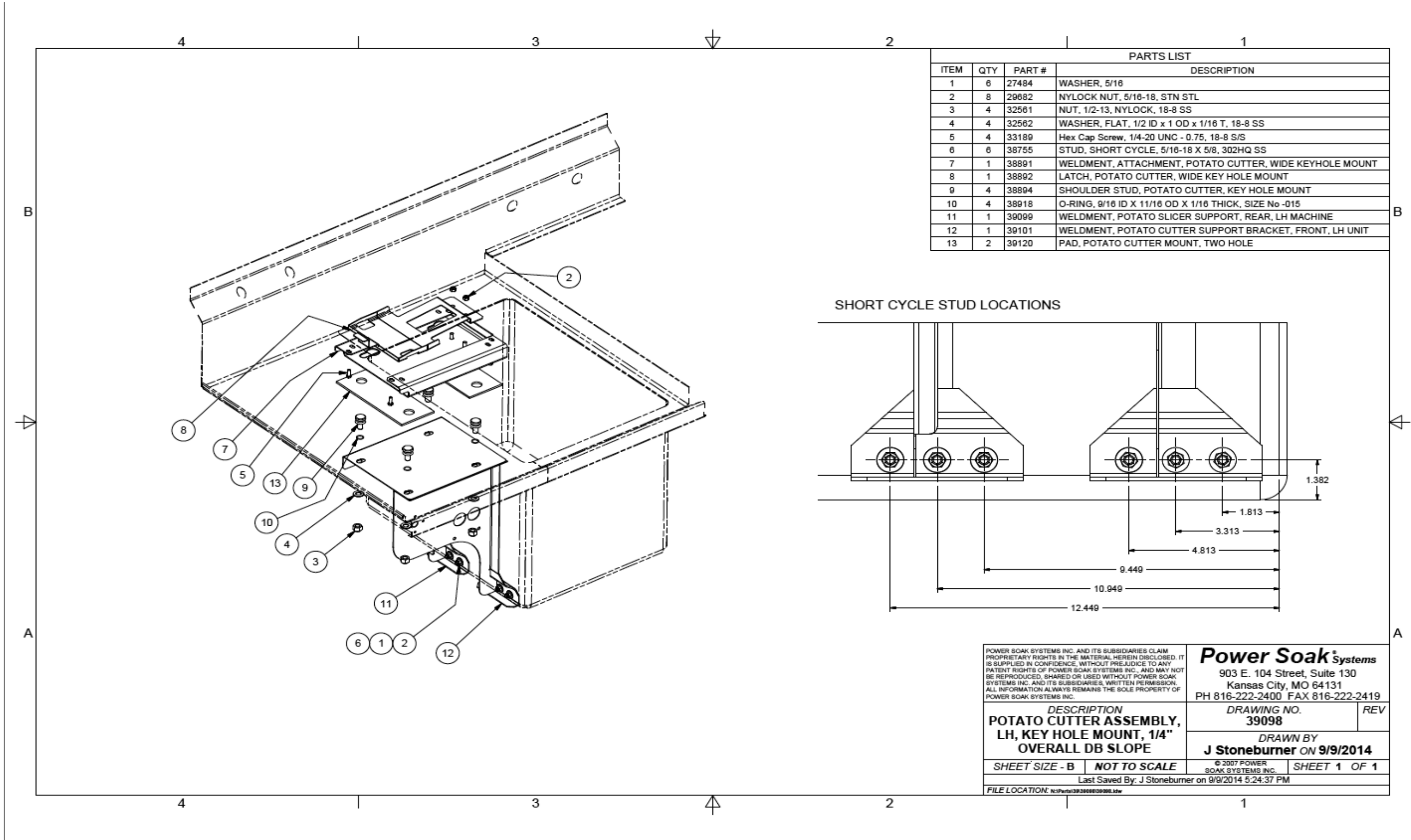

<small>POWER SOAK SYSTEMS INC. AND ITS SUBSIDIARIES CLAIM PROPRIETARY RIGHTS IN THE MATERIAL HEREIN DISCLOSED. IT IS SUPPLIED IN CONFIDENCE, WITHOUT PREJUDICE TO ANY PATENT RIGHTS OF POWER SOAK SYSTEMS INC., AND MAY NOT BE REPRODUCED, SHARED OR USED WITHOUT POWER SOAK SYSTEMS INC. AND ITS SUBSIDIARIES, WRITTEN PERMISSION. ALL INFORMATION ALWAYS REMAINS THE SOLE PROPERTY OF POWER SOAK SYSTEMS INC.</small>		Power Soak Systems 903 E. 104 Street, Suite 130 Kansas City, MO 64131 PH 816-222-2400 FAX 816-222-2419	
DESCRIPTION POTATO CUTTER ASSEMBLY, LH, KEY HOLE MOUNT, 1/4" OVERALL DB SLOPE		DRAWING NO. 39098	REV
SHEET SIZE - B NOT TO SCALE		DRAWN BY J Stoneburner ON 9/9/2014	
© 2007 POWER SOAK SYSTEMS INC.		SHEET 1 OF 1	
Last Saved By: J Stoneburner on 9/9/2014 5:24:37 PM			
FILE LOCATION: H:\P\p\39098\39098.dwg			

PARTS LIST

ITEM	QTY	PART #	DESCRIPTION
1	1	38564	VOLUTE, FLUSHING, LH, WELDMENT
2	4	38653	ADAPTER, STRAIGHT, 3/8 MPT x 1/2 PUSH-IN TUBE SOCKET
3	3	38654	ADAPTER, SWIVEL 90 EL, 1/2 MPT x 1/2 PUSH-IN TUBE SOCKET
4	1	38655	WYE, 1/2 PUSH-IN TUBE SOCKET
5	1	38674	PLUG, 1/2 NPT, PVC
6	1	38689	VALVE, SELECTOR, 5-PORT, 1/2 NPT, LOW LEAD BRASS, NO HANDLE
7	4	32896	Slotted Pan Head Machine Screw, 10-24 UNC x 1-1/4, 18-8 SS
8	1	40031	FIVE GUYS PUMP FLUSH TUBE, WYE SUPPLY, LH
9	1	39075	HANDLE, SELECTOR VALVE, DIP COATED
10	1	38700	ACORN NUT, 3/8-24 UNF, 18-8 SS
11	1	38701	LABEL, SELECTOR VALVE
12	1	40032	FIVE GUYS PUMP FLUSH TUBE, SEAL, LH
13	1	40033	FIVE GUYS PUMP FLUSH TUBE, IMPELLER, LH
14	1	40034	FIVE GUYS PUMP FLUSH TUBE, SHELF, LH
15	1	40035	FIVE GUYS PUMP FLUSH TUBE, TANGENTIAL, LH
16	1	39564	VALVE, DOUBLE CHECK BACKSIPHONAGE PREVENTION, 3/4 NPT, LEAD FREE
17	1	39568	REDUCER BUSHING 3/4NPT X 1/2NPT, BRASS
18	1	39569	NIPPLE, 3/4 NPT X 2" LONG
19	1	39567	SUPPORT BRACKET, DOUBLE CHECK VALVE

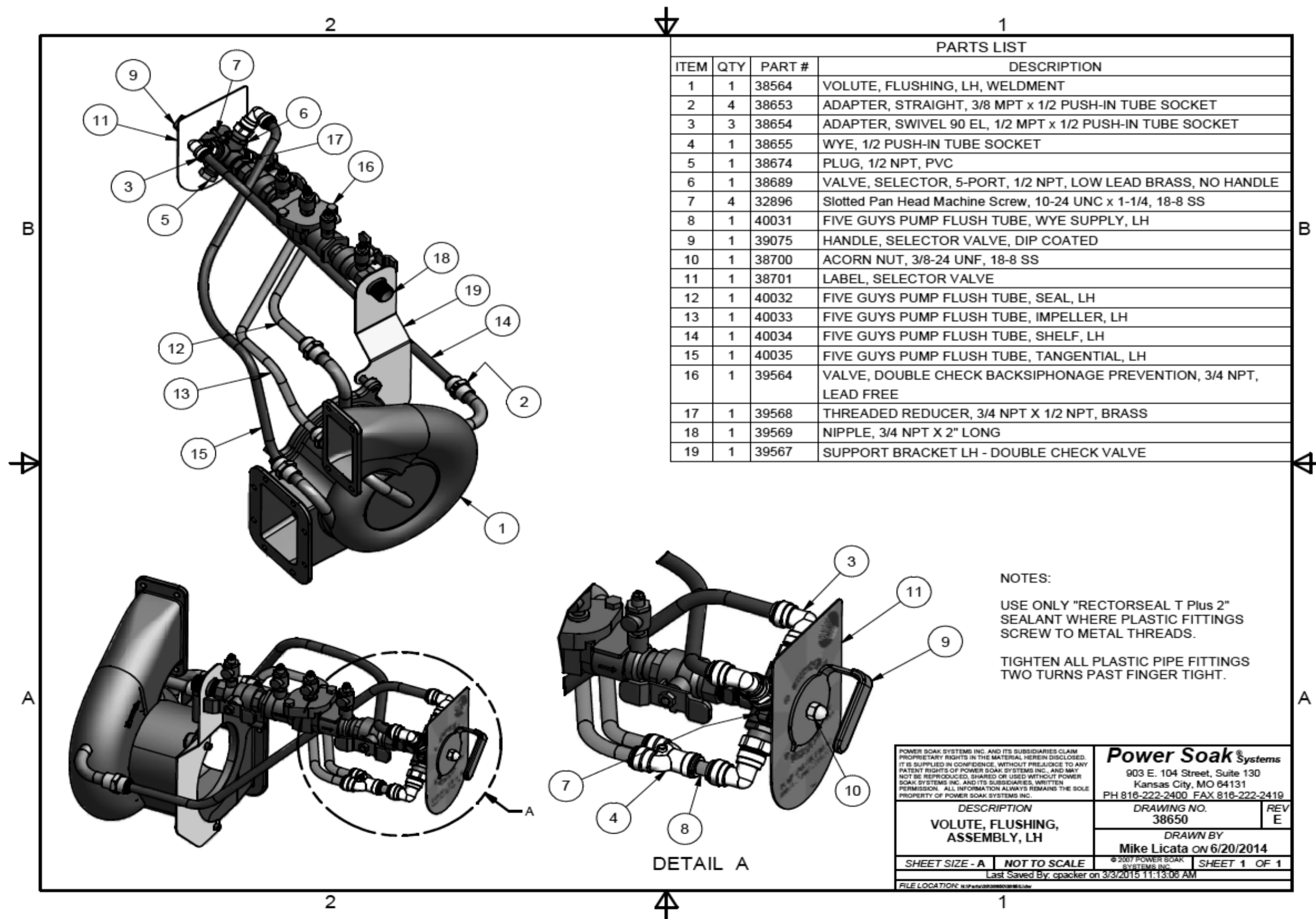

PARTS LIST			
ITEM	QTY	PART #	DESCRIPTION
1	1	38564	VOLUTE, FLUSHING, LH, WELDMENT
2	4	38653	ADAPTER, STRAIGHT, 3/8 MPT x 1/2 PUSH-IN TUBE SOCKET
3	3	38654	ADAPTER, SWIVEL 90 EL, 1/2 MPT x 1/2 PUSH-IN TUBE SOCKET
4	1	38655	WYE, 1/2 PUSH-IN TUBE SOCKET
5	1	38674	PLUG, 1/2 NPT, PVC
6	1	38689	VALVE, SELECTOR, 5-PORT, 1/2 NPT, LOW LEAD BRASS, NO HANDLE
7	4	32896	Slotted Pan Head Machine Screw, 10-24 UNC x 1-1/4, 18-8 SS
8	1	40031	FIVE GUYS PUMP FLUSH TUBE, WYE SUPPLY, LH
9	1	39075	HANDLE, SELECTOR VALVE, DIP COATED
10	1	38700	ACORN NUT, 3/8-24 UNF, 18-8 SS
11	1	38701	LABEL, SELECTOR VALVE
12	1	40032	FIVE GUYS PUMP FLUSH TUBE, SEAL, LH
13	1	40033	FIVE GUYS PUMP FLUSH TUBE, IMPELLER, LH
14	1	40034	FIVE GUYS PUMP FLUSH TUBE, SHELF, LH
15	1	40035	FIVE GUYS PUMP FLUSH TUBE, TANGENTIAL, LH
16	1	39564	VALVE, DOUBLE CHECK BACKSIPHONAGE PREVENTION, 3/4 NPT, LEAD FREE
17	1	39568	THREADED REDUCER, 3/4 NPT X 1/2 NPT, BRASS
18	1	39569	NIPPLE, 3/4 NPT X 2" LONG
19	1	39567	SUPPORT BRACKET LH - DOUBLE CHECK VALVE

NOTES:
 USE ONLY "RECTORSEAL T Plus 2" SEALANT WHERE PLASTIC FITTINGS SCREW TO METAL THREADS.
 TIGHTEN ALL PLASTIC PIPE FITTINGS TWO TURNS PAST FINGER TIGHT.

<small>POWER SOAK SYSTEMS INC. AND ITS SUBSIDIARIES CLAIM PROPRIETARY RIGHTS IN THE MATERIAL HEREIN DISCLOSED. IT IS SUPPLIED IN CONFIDENCE, WITHOUT PREJUDICE TO ANY PATENT RIGHTS OF POWER SOAK SYSTEMS INC. AND MAY NOT BE REPRODUCED, SHARED OR USED WITHOUT POWER SOAK SYSTEMS INC. AND ITS SUBSIDIARIES' WRITTEN PERMISSION. ALL INFORMATION ALWAYS REMAINS THE SOLE PROPERTY OF POWER SOAK SYSTEMS INC.</small>		Power Soak Systems 903 E. 104 Street, Suite 130 Kansas City, MO 64131 PH 816-222-2400 FAX 816-222-2419	
DESCRIPTION VOLUTE, FLUSHING, ASSEMBLY, LH		DRAWING NO. 38650	REV E
SHEET SIZE - A NOT TO SCALE		DRAWN BY Mike Licata ON 6/20/2014	
Last Saved By: cpacker on 3/3/2015 11:13:08 AM		SHEET 1 OF 1	

PARTS LIST

ITEM	QTY	PART #	DESCRIPTION
1	1	38564	VOLUTE, FLUSHING, LH, WELDMENT
2	4	38653	ADAPTER, STRAIGHT, 3/8 MPT x 1/2 PUSH-IN TUBE SOCKET
3	3	38654	ADAPTER, SWIVEL 90 EL, 1/2 MPT x 1/2 PUSH-IN TUBE SOCKET
4	1	38655	WYE, 1/2 PUSH-IN TUBE SOCKET
5	1	38674	PLUG, 1/2 NPT, PVC
6	1	38689	VALVE, SELECTOR, 5-PORT, 1/2 NPT, LOW LEAD BRASS, NO HANDLE
7	4	32896	Slotted Pan Head Machine Screw, 10-24 UNC x 1-1/4, 18-8 SS
8	1	40036	FIVE GUYS PUMP FLUSH TUBE, WYE SUPPLY, RH
9	1	40037	FIVE GUYS PUMP FLUSH TUBE, SEAL, RH
10	1	40038	FIVE GUYS PUMP FLUSH TUBE, IMPELLER, RH
11	1	40040	FIVE GUYS PUMP FLUSH TUBE, TANGENTIAL, RH
12	1	40039	FIVE GUYS PUMP FLUSH TUBE, SHELF, RH
13	1	39075	HANDLE, SELECTOR VALVE, DIP COATED
14	1	38700	ACORN NUT, 3/8-24 UNF, 18-8 SS
15	1	38701	LABEL, SELECTOR VALVE
16	1	39568	REDUCER BUSHING 3/4NPT X 1/2NPT, BRASS
17	1	39564	VALVE, DOUBLE CHECK BACKSIPHONAGE PREVENTION, 3/4 NPT, LEAD FREE
18	1	39569	NIPPLE, 3/4 NPT X 2" LONG
19	1	39570	SUPPORT BRACKET RH, DOUBLE CHECK VALVE

PARTS LIST

ITEM	QTY	PART #	DESCRIPTION
1	1	38566	VOLUTE, FLUSHING, LH, WELDMENT
2	4	38653	ADAPTER, STRAIGHT, 3/8 MPT x 1/2 PUSH-IN TUBE SOCKET
3	3	38654	ADAPTER, SWIVEL 90 EL, 1/2 MPT x 1/2 PUSH-IN TUBE SOCKET
4	1	38655	WYE, 1/2 PUSH-IN TUBE SOCKET
5	1	38674	PLUG, 1/2 NPT, PVC
6	1	38689	VALVE, SELECTOR, 5-PORT, 1/2 NPT, LOW LEAD BRASS, NO HANDLE
7	4	32896	Slotted Pan Head Machine Screw, 10-24 UNC x 1-1/4, 18-8 SS
8	1	40036	FIVE GUYS PUMP FLUSH TUBE, WYE SUPPLY, RH
9	1	40037	FIVE GUYS PUMP FLUSH TUBE, SEAL, RH
10	1	40038	FIVE GUYS PUMP FLUSH TUBE, IMPELLER, RH
11	1	40040	FIVE GUYS PUMP FLUSH TUBE, TANGENTIAL, RH
12	1	40039	FIVE GUYS PUMP FLUSH TUBE, SHELF, RH
13	1	39075	HANDLE, SELECTOR VALVE, DIP COATED
14	1	38700	ACORN NUT, 3/8-24 UNF, 18-8 SS
15	1	38701	LABEL, SELECTOR VALVE
16	1	39568	THREADED REDUCER, 3/4 NPT X 1/2 NPT, BRASS
17	1	39564	VALVE, DOUBLE CHECK BACKSIPHONAGE PREVENTION, 3/4 NPT, LEAD FREE
18	1	39569	NIPPLE, 3/4 NPT X 2" LONG
19	1	39570	SUPPORT BRACKET RH - DOUBLE CHECK VALVE

NOTES:

USE ONLY "RECTORSEAL T Plus 2" SEALANT WHERE PLASTIC FITTINGS SCREW TO METAL THREADS.

TIGHTEN ALL PLASTIC PIPE FITTINGS TWO TURNS PAST FINGER TIGHT.

POWER SOAK SYSTEMS INC. AND ITS SUBSIDIARIES CLAIM PROPRIETARY RIGHTS IN THE MATERIAL HEREIN DISCLOSED. IT IS SUPPLIED IN CONFIDENCE. WITHOUT PREJUDICE TO ANY PATENT RIGHTS OF POWER SOAK SYSTEMS INC. AND MAY NOT BE REPRODUCED, SHARED OR USED WITHOUT POWER SOAK SYSTEMS INC. AND ITS SUBSIDIARIES WRITTEN PERMISSION. ALL INFORMATION ALWAYS REMAINS THE SOLE PROPERTY OF POWER SOAK SYSTEMS INC.

Power Soak Systems
 903 E. 104 Street, Suite 130
 Kansas City, MO 64131
 PH 816-222-2400 FAX 816-222-2419

DESCRIPTION VOLUTE, FLUSHING, ASSEMBLY, RH	DRAWING NO. 38651	REV E
DRAWN BY Mike Licata on 5/29/2014		
SHEET SIZE - A	NOT TO SCALE	SHEET 1 OF 1

© 2007 POWER SOAK SYSTEMS INC.
 Last Saved By: cpacker on 3/3/2015 10:15:59 AM
 FILE LOCATION: s:\psoak\38651.dwg

Parts List

Item	QTY	Part#	DESCRIPTION
1	1	36469	CONTROL BOX, PS-50 ENCLOSURE, WELDMENT
2	1	32547	DISCONNECT HANDLE ASSEMBLY
3	2	29776	NUT SERT 10-24 UNC
4	2	29849	#10-24 x 3/4 Cross Recessed Pan Head Machine Screw
5	1	36483	DOOR GASKET, PS-50 CONTROL BOX
6	1	32541	DIN RAIL, 4 INCHES LG
7	2	32898	10-24 NYLOCK HEX NUT, 18-8 SS
8	1	32542	DISCONNECT SWITCH
9	1	32546	DISCONNECT SHAFT
10	2	31928	CLAMP END DIN RAIL MOUNT
11	1	31927	TERMINAL 10MM GROUNDING DIN RAIL
12	1	33711	DISCONNECT LABEL

Parts List			
ITEM	QTY	PART NUMBER	DESCRIPTION
1	1	36469	CONTROL BOX, PS-50 ENCLOSURE, WELDMENT
2	1	32547	DISCONNECT HANDLE ASSEMBLY
3	2	29776	NUT SERT 10-24 UNC
4	2	29849	#10-24 x 3/4 Cross Recessed Pan Head Machine Screw
5	1	36483	DOOR GASKET, PS-50 CONTROL BOX
6	1	32541	DIN RAIL, 4 INCHES LG
7	2	32898	10-24 NYLOCK HEX NUT, 18-8 SS
8	1	32542	DISCONNECT SWITCH
9	1	32546	DISCONNECT SHAFT
10	2	31928	CLAMP END DIN RAIL MOUNT
11	1	31927	TERMINAL 10MM GROUNDING DIN RAIL
12	1	33711	DISCONNECT LABEL

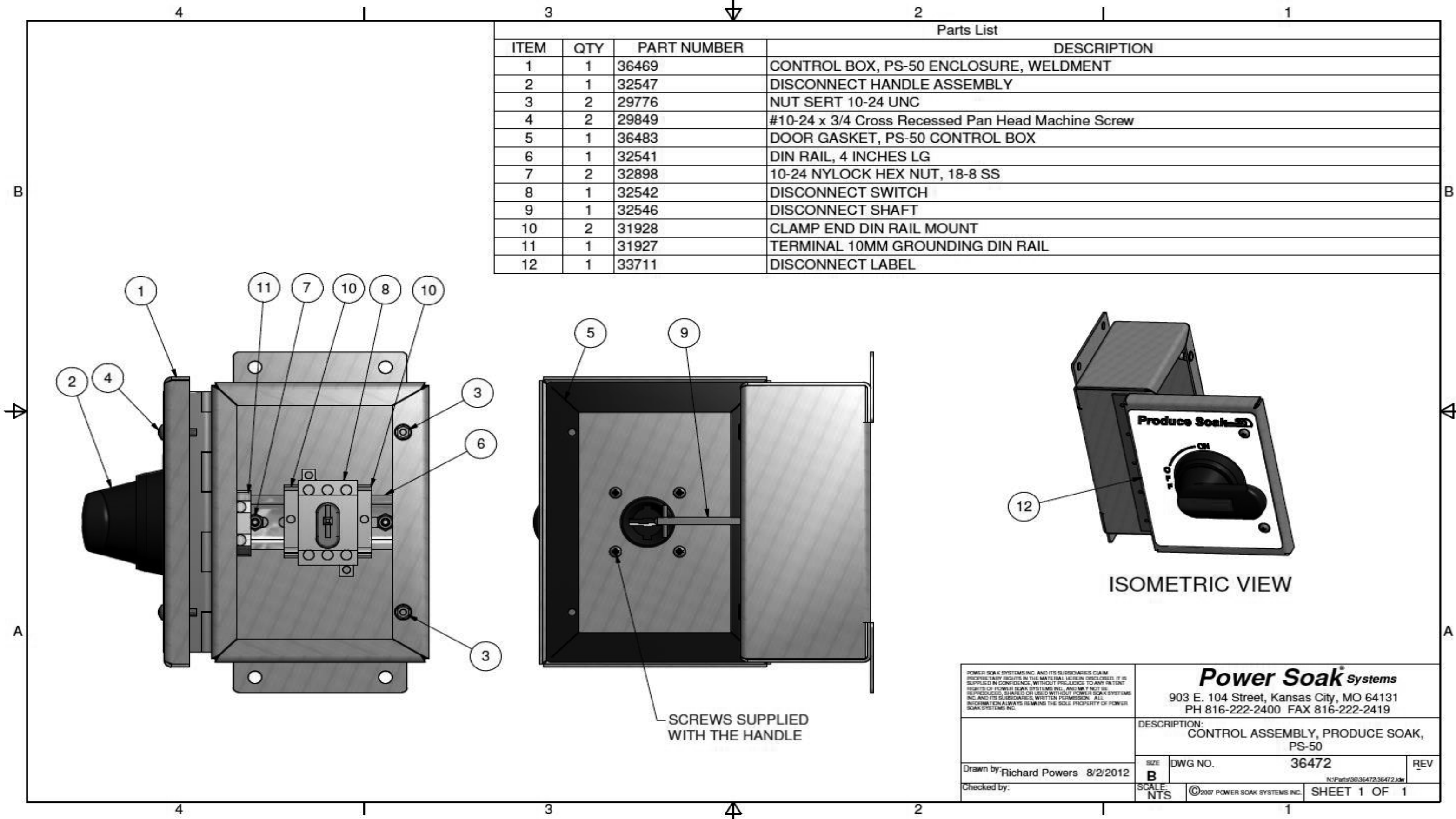

<small>POWER SOAK SYSTEMS INC. AND ITS SUBSIDIARIES CLAIM PROPRIETARY RIGHTS IN THE MATERIAL HEREIN DISCLOSED. IT IS SUPPLIED IN CONFIDENCE. WITHOUT PREJUDICE TO ANY PATENT RIGHTS OF POWER SOAK SYSTEMS INC. AND MAY NOT BE REPRODUCED, REARED, OR USED WITHOUT POWER SOAK SYSTEMS INC. AND ITS SUBSIDIARIES WRITTEN PERMISSION. ALL INFORMATION ALWAYS REMAINS THE SOLE PROPERTY OF POWER SOAK SYSTEMS INC.</small>		Power Soak Systems 903 E. 104 Street, Kansas City, MO 64131 PH 816-222-2400 FAX 816-222-2419	
Drawn by: Richard Powers 8/2/2012 Checked by:		DESCRIPTION: CONTROL ASSEMBLY, PRODUCE SOAK, PS-50	
SIZE B	DWG NO. 36472	REV	N:\Part\30\36472\36472.dwg
SCALE: NTS	©2007 POWER SOAK SYSTEMS INC.	SHEET 1 OF 1	

PARTS LIST			
Item	QTY	PART #	DESCRIPTION
1	1	32525	MOTOR, .75HP 1160 RPM 208V 1PH
2	1	27594	IMPELLER 12-BLADE, LH/RH
3	1	27525	SEAL PLATE, SELF-DRAIN
4	1	27481	PUMP SHAFT SLEEVE
5	1	27477	KEY
6	1	27479	PUMP GASKET (FIBER WASHER)
7	1	27475	PUMP QUAD RING, SLEEVE, PS-200
8	1	27476	O-RING, SEAL PLATE, PS-200
9	4	27483	CAP SCREW, SEAL PLATE, PS-200
10	1	27478	PUMP IMPELLER BOLT PS-200
11	1	27480	PUMP MECHANICAL SEAL ASSY

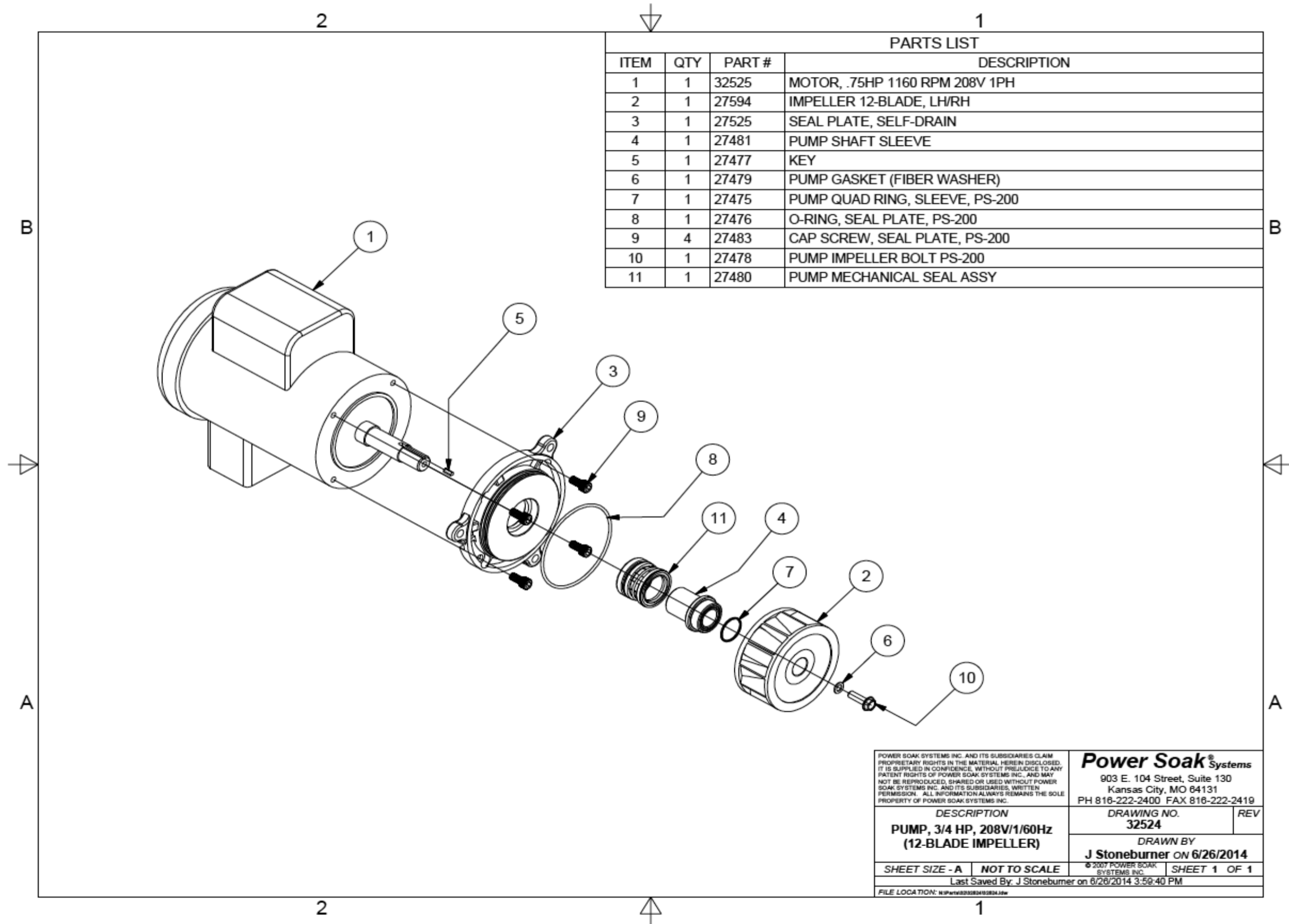

PARTS LIST			
ITEM	QTY	PART #	DESCRIPTION
1	1	32525	MOTOR, .75HP 1160 RPM 208V 1PH
2	1	27594	IMPELLER 12-BLADE, LH/RH
3	1	27525	SEAL PLATE, SELF-DRAIN
4	1	27481	PUMP SHAFT SLEEVE
5	1	27477	KEY
6	1	27479	PUMP GASKET (FIBER WASHER)
7	1	27475	PUMP QUAD RING, SLEEVE, PS-200
8	1	27476	O-RING, SEAL PLATE, PS-200
9	4	27483	CAP SCREW, SEAL PLATE, PS-200
10	1	27478	PUMP IMPELLER BOLT PS-200
11	1	27480	PUMP MECHANICAL SEAL ASSY

POWER SOAK SYSTEMS INC. AND ITS SUBSIDIARIES CLAIM PROPRIETARY RIGHTS IN THE MATERIAL HEREIN DISCLOSED. IT IS SUPPLIED IN CONFIDENCE, WITHOUT PREJUDICE TO ANY PATENT RIGHTS OF POWER SOAK SYSTEMS INC. AND MAY NOT BE REPRODUCED, SHARED OR USED WITHOUT POWER SOAK SYSTEMS INC. AND ITS SUBSIDIARIES' WRITTEN PERMISSION. ALL INFORMATION ALWAYS REMAINS THE SOLE PROPERTY OF POWER SOAK SYSTEMS INC.

Power Soak® Systems
 903 E. 104 Street, Suite 130
 Kansas City, MO 64131
 PH 816-222-2400 FAX 816-222-2419

DESCRIPTION	DRAWING NO.	REV
PUMP, 3/4 HP, 208V/1/60Hz (12-BLADE IMPELLER)	32524	
DRAWN BY		
J Stoneburner ON 6/26/2014		
SHEET SIZE - A	NOT TO SCALE	SHEET 1 OF 1
Last Saved By: J Stoneburner on 6/26/2014 3:59:40 PM		
FILE LOCATION: \\P016020004\JStoneburner		