

Power Soak[®]

SERVICE MANUAL

PS-200 & PS-201



Table of Contents

Explanation of Warning Messages.....	1
Danger.....	1
Warning.....	1
Personal Injury Hazard.....	1
Chemical Hazard.....	1
Preventive Maintenance	2
Daily.....	2
Monthly	2
Troubleshooting.....	3
Hazard to Untrained or Unauthorized Personnel.....	3
Pump leaks.....	3
Intermittent running.....	3
Pump does not work.....	4
Pump works- Heater does not work.....	4
Water too hot or not hot enough.....	4
No Power	5
Error Codes.....	5
Component Operation and Checks.....	7
Liquid Level Sensors.....	7
Thermistor	7
Heater Thermodisc (Hi-Limit or Cutoff Switch)	8
Transformer	8
Triac (Thyristor or Solid-State Relay).....	9
Contactor	9
Heater Element.....	9

Parts List.....	10
Motor – Impeller – Pump Assembly.....	10
Motor – Impeller- Pump Assembly.....	11
Motor – Impeller- Pump Assembly.....	11
Heater.....	13
Control Panel	14
Miscellaneous	14
Optional Chemical Dispenser.....	15
Electrical Schematic.....	16
208-240 volt 60 Hz 1 phase.....	16
208-230 volt 60 Hz 3 phase.....	17
460 volt 60 Hz 3 phase	18
Electrical Schematic (European).....	19
400 volt 50 Hz 3 phase	19
230 volt 50 Hz 3 phase	20
Motor and Pump Assembly.....	21
Exploded View.....	21
Motor and Pump Assembly & Disassembly Procedures	22
DISASSEMBLY PROCEDURE:	22
INSPECTION OF THE COMPONENTS:	22
ASSEMBLY PROCEDURE:.....	22
Appendix A.....	24

Explanation of Warning Messages

Read, understand and follow all DANGER, WARNING, and CAUTION messages located in this guide and on the equipment.

Danger

Personal Injury and Property Damage hazard.
May result in serious injury or death.
May cause extensive equipment damage.

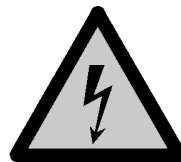

Warning

Property Damage Hazard.
May result in property or equipment damage.



Personal Injury Hazard

Hazard from sharp objects.
May result in serious injury or death.



Chemical Hazard

May result in serious injury or death. Instructions, labels and Material Safety Data Sheets (MSDSs) should be supplied with all detergents and sanitizing chemicals. The manufacturers, importers and distributors of your cleaning chemicals are responsible for providing this information.



Preventive Maintenance

Power Soak machines require minimal, routine preventive maintenance. As such, the following should be done on a routine basis to ensure that your system remains reliable:

Daily

Clean the liquid level sensors. These sensors are located on the side walls of the wash and sanitizer tanks. They are the white plastic discs with metal centers. **Clean the sensor faces thoroughly.** If cleaned regularly, a washcloth and soapy water are all that is required.

If the liquid level sensors are not cleaned regularly, the machine may fail to operate. Dirty sensors may create a situation that will allow the machine to run without water, which can cause serious damage to the unit.



Monthly

IMPORTANT: Turn off the power to the unit at the main breaker prior to performing the following task!

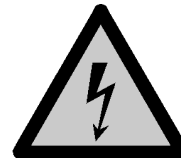

After shutting off the power at the system's dedicated breaker, **clean the pump motor fan shroud** with a stiff bristle brush and a vacuum. If a brush and vacuum are unavailable, clean the shroud with a damp, soapy rag. The motor shroud is the "vented" cover located at the end of the motor (closest to the control panel). This will prevent grease and dust from accumulating in the cover's openings, which can obstruct the airflow that cools the motor.

De-lime the wash sink. Simply add a de-liming agent to a sink of warm, fresh water and run the system overnight.

Ask your chemical sales representative to recommend a specific de-liming agent.

Note: The motor bearings do not need to be greased because they are permanently sealed. If you have any questions regarding the preventive maintenance procedures, please contact the factory at **800-444-9624**.

Troubleshooting

Hazard to Untrained or Unauthorized Personnel.

The following procedures are provided for use by an authorized service agency. No facility owner, manager, employee or other unauthorized person should attempt to perform any of these procedures. To obtain the name of a recommended service agent in your area, please call the Power Soak Service Department. **800-444-9624.**



When performing trouble shooting procedures, the authorized service agency will need to open the electrical enclosure on the Power Soak machine.

The control panel must be properly closed before reconnecting the power to the machine.

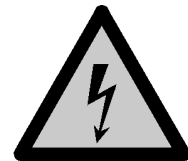

Pump leaks

Look for	Correction
1 Defective ADAPTER O-RING	Replace
2 Defective PUMP SEAL	Replace

Intermittent running

See "Pump does not work" below

Pump does not work

Look for	Correction
1 Slow flashing Green Light	Clean Liquid Level Sensors. Fill sink with water to proper level. Tighten the External Wiring Harness on back of Control Panel.
2 Solid Blue Light	Clean Liquid Level Sensors. Drain sink and refill with proper water level.
3 Error LED on UPM	Record the pattern – See “ Error Codes ”
4 Red, Green, Blue lights blinking together	Low power to UPM – See “ No Power ”
5 No indicator lights at all	Water too hot – reduce temperatures to 115° with ice or cold water See “ No Power ”

Pump works- Heater does not work

Look for	Correction
1 Water temperature < 110°F	Check Heater and replace as necessary. Check Triac(s) and replace as necessary.
2 Water temperature between 110°F and 120°F	Normal operating temperature.
3 Water temperature > 120°F	Check Thermistor and replace as necessary. Too much soap can cause excessive heat buildup

Water too hot or not hot enough

Look for	Correction
1 Water temperature < 110°F	Check Heater and replace as necessary. Check Triac(s) and replace as necessary.
2 Water temperature between 110°F and 120°F	Normal operating temperature.
3 Water temperature > 120°F	Check thermistor and replace as necessary. Too much soap can cause excessive heat buildup.

No Power

Look for	Correction
1 Incoming voltage between L1 and L2 (L1-L2) (Also L1-L3, L2-L3 if 3 phase)	Check Heater and replace as necessary.
2 Less than 10 volts to UPM (leave UPM plugged in during check)	Water too hot, above 135°F – empty sink and refill with 115°F water. Tighten the External Wiring Harness on back of Control Panel. Check transformer and replace as necessary. Check thermal cutoff for heater and replace as necessary. Check thermal cutoff for motor and replace as necessary.

Error Codes

~ Represents a “long” flash

* Represents a “short” flash

Look for	Correction
1 ~ ~ ~ * Liquid Level Error	This error appears when the upper liquid level sensor sends a signal to the UPM (W-H light is illuminated) and the low liquid level sensor is not sending a signal to the UPM (W-L is not illuminated). The low level sensor may not be functioning due to a coating of debris or a broken/disconnected wire that is preventing the signal to the UPM. A continuous signal from the upper level sensor can be caused by debris coating the face of the sensor or faulty wiring that has the sensor connection grounded to the wash tank when there is no fluid in the tank. The liquid level lights on the UPM can be used to help determine the problem.

<p>2 ~ ~ ~ * * Temperature Sensor Error</p>	<p>When the UPM receives a signal from the thermistor that is outside the range of the UPM programming, the temperature sensor error will actuate. The UPM will signal an error if it reads a resistance greater than 430 k and less than 15 k. Check and replace Thermistor as necessary.</p>
<p>3 ~ ~ ~ * * * Over Current Error</p>	<p>If any of the high voltage components begin drawing excessive current, the current sensor will send a signal to the UPM to start the Over Current Error and deactivate the contactor which turns the power off to the machine. Check and replace the transformer, motor and/or heater as necessary.</p>
<p>4 ~ ~ ~ * * * * Over Temperature Error</p>	<p>If the fluid temperature in the wash tank exceeds 135°F it will activate this error message and stop the machine. This error code cannot be reset until the fluid is drained below the low level sensor in the wash tank.</p>
<p>5 ~ ~ ~ * * * * * Current Sensor Error</p>	<p>The UPM must receive a signal from the current sensor to verify that it is connected and working. If it does not receive the signal, the UPM program will stop the machine and give this error code.</p>
<p>6 ~ ~ ~ * * * * * * Membrane Error</p>	<p>In the event that one of the control panel buttons sends a constant signal to the UPM, the program will recognize that the membrane is defective and display this error code (see Section 6.9 Push Button Membrane).</p>

Component Operation and Checks

The following checks should only be performed by qualified technicians using extreme caution. Electrical hazard to untrained personnel may result in electrical shock, burns, or death.

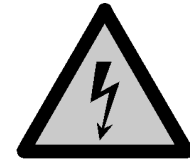

Liquid Level Sensors

There are two Liquid Level Sensors (LLS) in the wash sink, and two more in the sanitize sink (if equipped with a sanitize sink). To check operation, first unplug the white connector from the UPM. Using an Ohm meter, measure the resistance between the face of the LLS and the appropriate pin of the white connector. The meter should read less than one ohm. Refer to the chart below for the appropriate pins.

<u>Description</u>	<u>UPM pin number</u>	<u>Wire Color</u>
Wash Sink Low LLS	Pin 19	White with Orange stripe
Wash Sink High LLS	Pin 20	White with Green stripe
Sanitize Sink Low LLS	Pin 21	White with Yellow stripe
Sanitize Sink High LLS	Pin 22	White with Blue stripe

If the meter shows a reading higher than one Ohm, there may be a dirty sensor, a broken wire, or a loose connection. The loose connection may be at the sensor, the wiring harness, or the external wiring harness may not be tight at the back of the Control Panel.

Thermistor

The Thermistor is a temperature sensor. The UPM measures the resistance through the Thermistor, and associates that resistance to a temperature. To check operation, first unplug the white connector from the UPM. Next, measure the resistance across the Thermistor. This reading can be attained at the white UPM connector (reference "UPM" for pin layout), between pin 8 and pin 9. If the reading varies significantly from the Temperature-Resistance chart in Appendix A, the Thermistor may be defective. The UPM will signal an error if it reads a resistance greater than 430 k Ω and less than 15k Ω . The Thermistor is located close to the Heater, inside the Sensor Pad. When replacing a Thermistor, it is helpful to use a glue dot to hold it in place while reattaching the Sensor Pad to the sink. Also, it is imperative to put heat sink compound on the side of the Thermistor that will be against the sink, and the Heater Thermodisc as well, to help ensure good heat transfer.

Heater Thermodisc (Hi-Limit or Cutoff Switch)

The Heater Thermodisc is a protection device. If the temperature at the Thermodisc reaches 135°F, the disc opens, cutting off power to the UPM. To check operation, first shut off the circuit breaker to the sink. Next, unplug the connectors P9 and J10 from J9 and P10 for the Motor Thermodisc (reference schematic or “Motor Thermodisc” for location and description). Device should read less than one ohm when closed. If the reading is more than one ohm, the Thermodisc may be defective. Next, check for a short to ground. If there is a short to ground from either side of the Thermodisc, the Thermodisc is either defective, or there may be water in the sensor pad. This condition will keep the UPM from operating correctly. The Thermodisc is located close to the Heater, inside the Sensor Pad. When replacing a Thermodisc it is helpful to use a glue dot to hold it in place while reattaching the Sensor Pad to the sink. Also it is imperative to put heat sink compound on the side of the Thermodisc that will be against the sink, and the Thermistor as well, to help ensure good heat transfer.

Motor Thermodisc (Hi-Limit or Cutoff Switch)

The Motor Thermodisc is a protection device only the motor. If the temperature of the motor reaches 180°F, the disc opens, cutting off power to the UPM, and the UPM turns off the power to the motor. To check operation, first shut off the circuit breaker to the sink. Next, unplug the connectors P9 and J10 from J9 and P10 for the Motor Thermodisc (reference schematic for location and description). These connectors plug the two Thermodisc wires (black) to two yellow wires coming out of the internal wiring harness of the Control Panel. Measure the resistance between J9 and P10 (reference schematic, these are the black Thermodisc wires). The device should read less than one ohm when closed. If the reading is more than one ohm, the Thermodisc may be defective. Next, check for a short to ground. If there is a short to ground from either side of the Thermodisc, the Thermodisc is either defective or there may be water on the Thermodisc. This condition will keep the UPM from operating correctly. On some of the Power Soak motors, the Thermodisc is built in to the motor, which is not replaceable. On others, it is located in the wiring box of the Motor, which is replaceable. When replacing, it is imperative to put heat sink compound on the side of the Thermodisc that will be against the motor to help ensure good heat transfer.

Transformer

The Transformer reduces the incoming power supply voltage to 24 volts, with a 12-volt center-tap. The transformer has acceptable inputs of 120, 240, and 277 volts. It should already be wired to the specifications of the Control Panel (refer to schematic). To test the Transformer, first verify the input voltage. This can be done between the L2 terminal and the down-stream/transformer side of the fuse. The fuse holder can be found on the end of the terminal strip. Next, verify the output voltage of the Transformer. The reading should be 24 volts across the outputs, and 12 volts between the center-tap and each of the other outputs. These voltages can be verified at the three wire nuts on the internal wiring harness near the Transformer. Note the wire colors on the schematic for each wire nut.

Triac (Thyristor or Solid-State Relay)

The Triac is a three terminal semiconductor for controlling current in either direction. The Triac in the Power Soak is used similar to a contactor. When a gate voltage is applied from the UPM (similar to coil voltage on a mechanical Contactor Relay), the Triac conducts (closes) through the power terminals. On a single phase Control Panel, there are two Triacs, one for the Heater, the other for the Motor. Terminals 2 and 3 on each Triac are supplied with incoming voltage. On the top of these Triacs, they are labeled M1 (motor leg 1) and H1 (heater leg 1). On a three phase Control Panel there are four Triacs, two for the Heater, and two for the Motor. Two are labeled identically to a single phase Panel. The two others are labeled M3 (motor leg 3) and H3 (heater leg 3). Terminals 2 and 3 on each Triac are supplied with incoming voltage. To test the Triac, first verify the input voltage to the Triac. An LED on the Triac board signals whether the gate voltage has been applied by the UPM. If the light is on, the Triac should be closed, and terminal 1 of the Triac should be supplying power to the respective device. If the LED is off, there should be virtually no current on the output side of the Triac.

Contactor

If there is a 20v-28v across the coil and the contactor does not pull in, the contactor is defective. If there is input voltage across terminals L1 and L2 (also L1-L3 and L2-L3, if three phase) and the contactor is pulled in, but no voltage across terminals T1 and T2 (also T1-T3 and T2-T3, if three phase), the contactor is defective.

Heater Element

The heater in a Power Soak sink is rated at 7000 watts. To check operations of the heat element, first turn the power off at the breaker. Disconnect the H2 wire from terminal H2 and the H1 wire from the triac H1 (and H3 wire from H3 triac, if 3 phase) from the Control Panel. Check each heater lead to ground for short. They all should be open to ground. Check resistance between each of the combinations of the chart below.

<u>Connection</u>	<u>Heater Rated Voltage</u>	<u>phase</u>	<u>Resistance (ohms)</u>
H1-H2	208-230	1	7.56
H1-H2	208-230	3	15.12
H2-H3	208-230	3	15.12
H1-H3	208-230	3	15.12
H1-H2	460	1	32.91
H1-H2	460	3	65.83
H2-H3	460	3	65.83
H1-H3	460	3	65.83

The heater should be within a 10% variance of the value of the chart.

If the reading varies significantly from the chart above, the heater may be defective, or there may be a broken wire or loose connection. Electrically, the Heater is three separate elements, each of 2333 watts. When replacing, note how the existing Heater is wired, and refer to the schematic when wiring new heater.

Parts List

Motor - Impeller - Pump Assembly

60 Hz - Self-Draining					
HP	Side	Phase	Volt	Motor	Impeller
1.5	LH	1	208	29506	27590
1.5	RH	1	208	29506	27591
1.5	LH	1	230	29500	27590
1.5	RH	1	230	29500	27591
1.5	LH	3	208	29508	27590
1.5	RH	3	208	29508	27591
1.5	LH	3	230/460	29502	27590
1.5	RH	3	230/460	29502	27591
2.0	LH	1	208	29507	27592
2.0	RH	1	208	29507	27593
2.0	LH	1	230	29501	27592
2.0	RH	1	230	29501	27593
2.0	LH	3	208	29509	27592
2.0	RH	3	208	29509	27593
2.0	LH	3	230/460	29503	27592
2.0	RH	3	230/460	29503	27593
3.0	LH/RH	3	208	29510	27594
3.0	LH/RH	3	230/460	29504	27594
5.0	LH	3	208	29511	27596
5.0	RH	3	208	29511	27597
5.0	LH	3	230/460	29505	27596
5.0	RH	3	230/460	29505	27597

Motor - Impeller- Pump Assembly

60 Hz - Not Self-Draining					
HP	Side	Phase	Volt	Motor	Impeller
1.5	LH	1	208/230	see above	27590
2.0	LH	1	208/230	see above	27592
2.0	LH	3	230/460	see above	27592
3.0	LH	3	230/460	see above	27594

Motor - Impeller- Pump Assembly

50 Hz - European					
HP	side	Phase	Volt	Motor	Impeller
1.5	LH	1	220	29512	27592
1.5	RH	1	220	29512	27593
1.5	LH	3	380	29514	27592
1.5	RH	3	380	29514	27593
2.0	LH/RH	1	220	29513	27594
2.0	LH/RH	3	380	29515	27594
3.0	LH	3	380	29516	27488
3.0	RH	3	380	29516	27489
5.0	LH	3	380	29517	?
5.0	RH	3	380	29517	?

Pump Parts Common to all

Part #	Description
28920	Seal Kit
27886	Thermodisc-motor-thermal cutoff
27047	Intake gasket
27132	Discharge gasket
*27480	Mechanical Seal
*27475	"O" ring – sleeve
*27476	"O" ring – seal plate
27477	Key
*27478	Impeller Bolt
*27479	Fiber Washer
27481	Sleeve
27483	Cap Screw – seal plate
28262	Dowel Pin

* These items are contained in seal kit 28920

Heater

Part #	Description
27743	Element - 230 volt - rev. A - ribbon - rear mount
27744	Element - 460 volt - rev. A - ribbon - rear mount
27839	Gasket for Chromolex heater
29243	Element - 208 volt - rev. B - wire - bottom mount - not available yet
27930	Element - 230 volt - rev. B - wire - bottom mount
29244	Element - 380 volt - rev. B - wire - bottom mount - not available yet
27939	Element - 480 volt - rev. B - wire - bottom mount
27934	Gasket for Accutherm heater
27702	Cover - rev. A - front mount - 17"
27934	Cover - rev. B - angle mount - 14"
27702	Cover - rev. C - after 02/05/04 - 12"
27934	Bolt - heater cover
18797	Terminal strip - heater
27926	Thermistor - temperature sensor
28454	Thermodisc - heater - thermal cutoff
27322	Sensor pad
28928	Heatsink compound
29077	Retainer Plate

Control Panel

Parts #	Description
27901	Control Panel 220 volt single phase
27902	Control Panel 220 volt three phase
27903	Control Panel 480 volt three phase
27171	Contactor
27172	Transformer - 24 volt
27920	UPM - Programming Module
27923	Terminal Block
27924	Grounding Block
27925	Din Rail - mount for terminal blocks
27928	Triac - solid state relay
28923	Fuse Block
27927	Heatsink
27200	Overlay - start/stop membrane
27922	Wiring Harness - internal to control panel

Miscellaneous

Part #	Description
23987	Liquid Level Sensor
23988	Gasket - Liquid Level Sensor
27847	Wiring Harness - Wash
27848	Wiring Harness - Sanitize
28065	Wiring Harness Extension - 3ft
28066	Wiring Harness Extension - 6ft
28669	Utensil Basket
27854	Chemical Injector
27854	Connector - chemical injector
28553	Cap - chemical injector
27855	Gasket - chemical injector

Optional Chemical Dispenser

Dual Pump Chemical Dispenser	
Part #	Description
28900	Chemical Dispenser - Dual Pump - Generic
28370	Chemical Dispenser - Dual Pump - Kay Chemical
29233	Timer - solidstate
29230	Button Guard - metal
29231	Switch - MOM - N/O - metal
29232	Rectifier - bridge
29235	Lock & Key
29234	Motor - 24 volt - 120 rpm
28067	Wiring Harness - soap dispenser
29236	Hook & Loop
29237	Screw - #8-32 x 1/2" flat phillips s/s
29238	Spring Cone
29239	Screw - #10-24 x 1 3/4" pan phillips s/s
29240	Pump - 2 cc power wash
29241	Tape - double sided foam
29242	Key
28703	Screw - #6-32 s/s
28704	Nut - hex #6-32 s/s
103-014	Nut Sert - #10-24 tsn
27858	Gasket - soap dispenser - PS-200
28557	Overlay - soap dispenser - Kay Chemical
28901	Overlay - soap dispenser - generic
29145	Terminal Fork 22-18 #8 Insulated
28555	Decal - Overlay - Metcraft service

Electrical Schematic

208-240 volt 60 Hz 1 phase

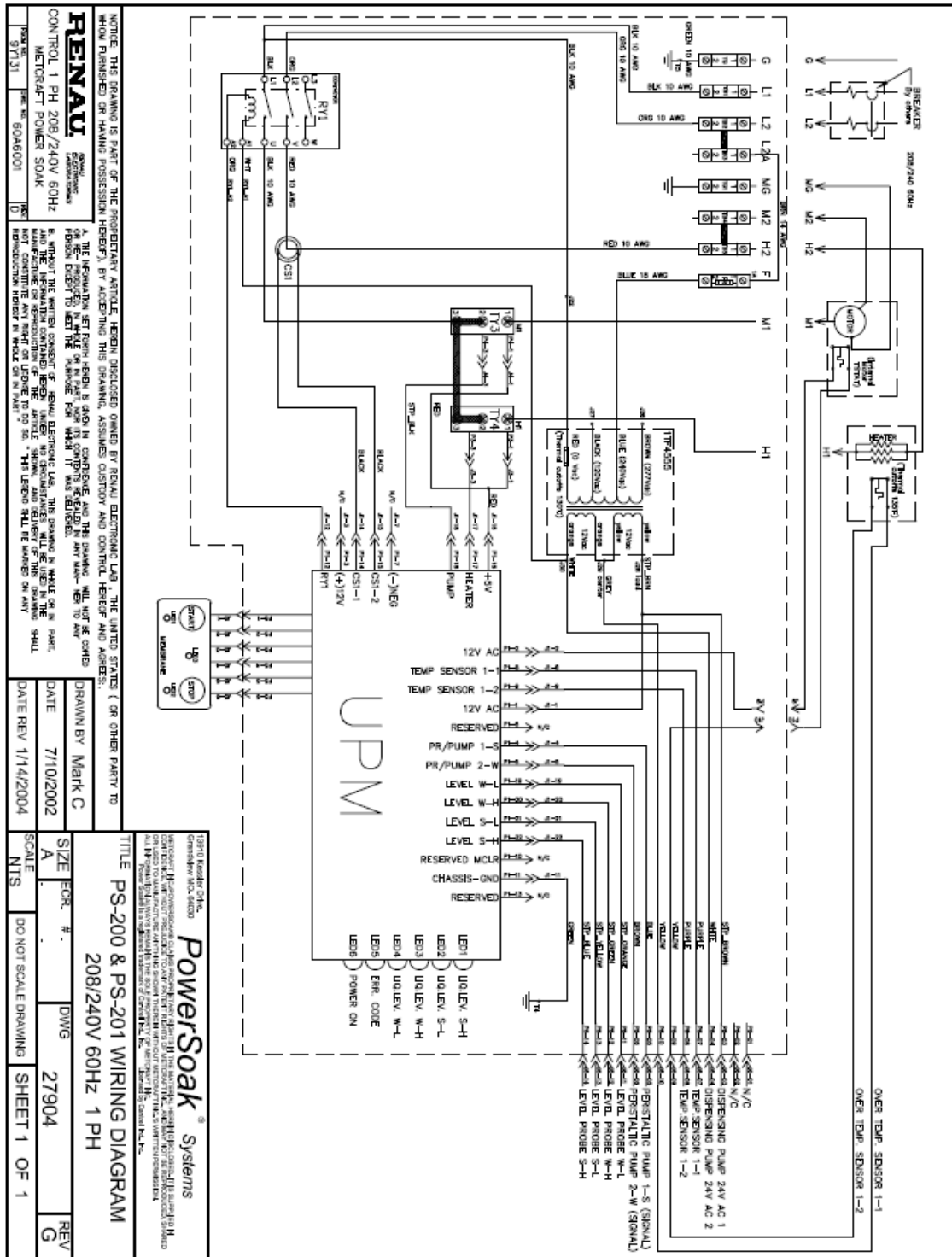

NOTICE: THIS DRAWING IS PART OF THE PROPRIETARY ARTICLE, HEREBY DISCLOSED OWNED BY RENAU ELECTRONIC LAB., THE UNITED STATES (OR OTHER PARTY TO WHOM LICENSED OR HAVING POSSESSION HEREBY), BY ACCEPTING THIS DRAWING, ASSUMES CUSTODY AND CONTROL, HEREBY AND AGREES:

RENAU ELECTRONIC LAB.
 CONTROL 1 PH 208/240V 60Hz
 METROFAST POWER SOAK

1. THE INFORMATION SET FORTH HEREIN IS CONFIDENTIAL AND THE DRAWING WILL NOT BE COPIED OR REPRODUCED IN WHOLE OR IN PART FOR ANY PURPOSE WITHOUT THE WRITTEN CONSENT OF RENAU ELECTRONIC LAB. THIS DRAWING IS MADE ON A PART OF THE INFORMATION SET FORTH HEREIN WHICH IT WAS BELIEVED TO BE NECESSARY TO THE PRODUCTION OF THE ARTICLE SHOWN, AND BELIEVED TO BE NECESSARY TO THE PRODUCTION OF THE ARTICLE SHOWN, AND BELIEVED TO BE NECESSARY TO THE PRODUCTION OF THE ARTICLE SHOWN.

DATE REV 1/14/2004
 DRAWN BY Mark C
 DATE 7/10/2002

13910 Wessler Ck.,
 Conestoga, PA 17330
 PowerSoak® systems
 TITLE PS-200 & PS-201 WIRING DIAGRAM
 208/240V 60Hz 1 PH
 SCALE A
 SIZE FOR # DWG 27904
 DO NOT SCALE DRAWING SHEET 1 OF 1



208-230 volt 60 Hz 3 phase

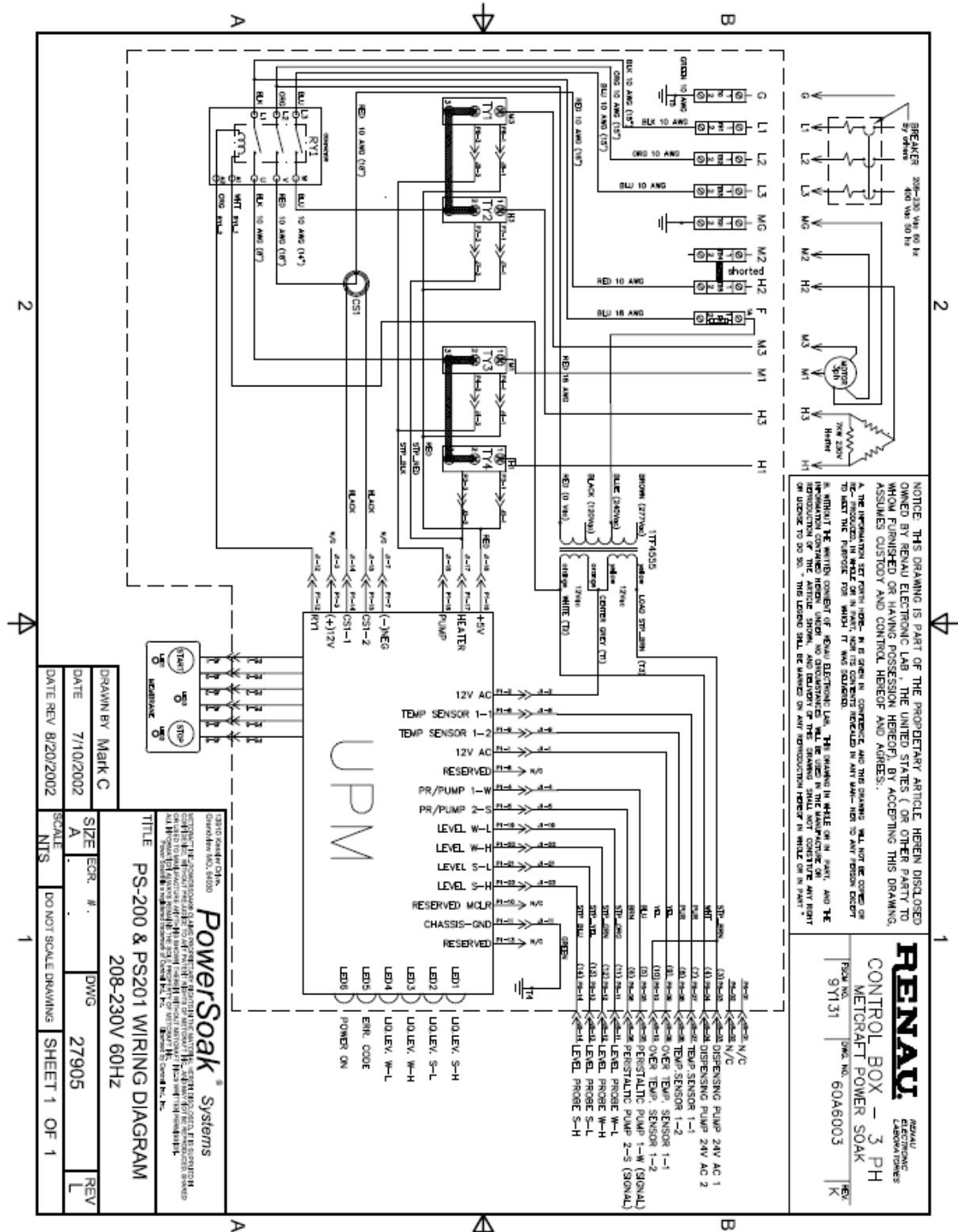

Motor and Pump Assembly

Exploded View

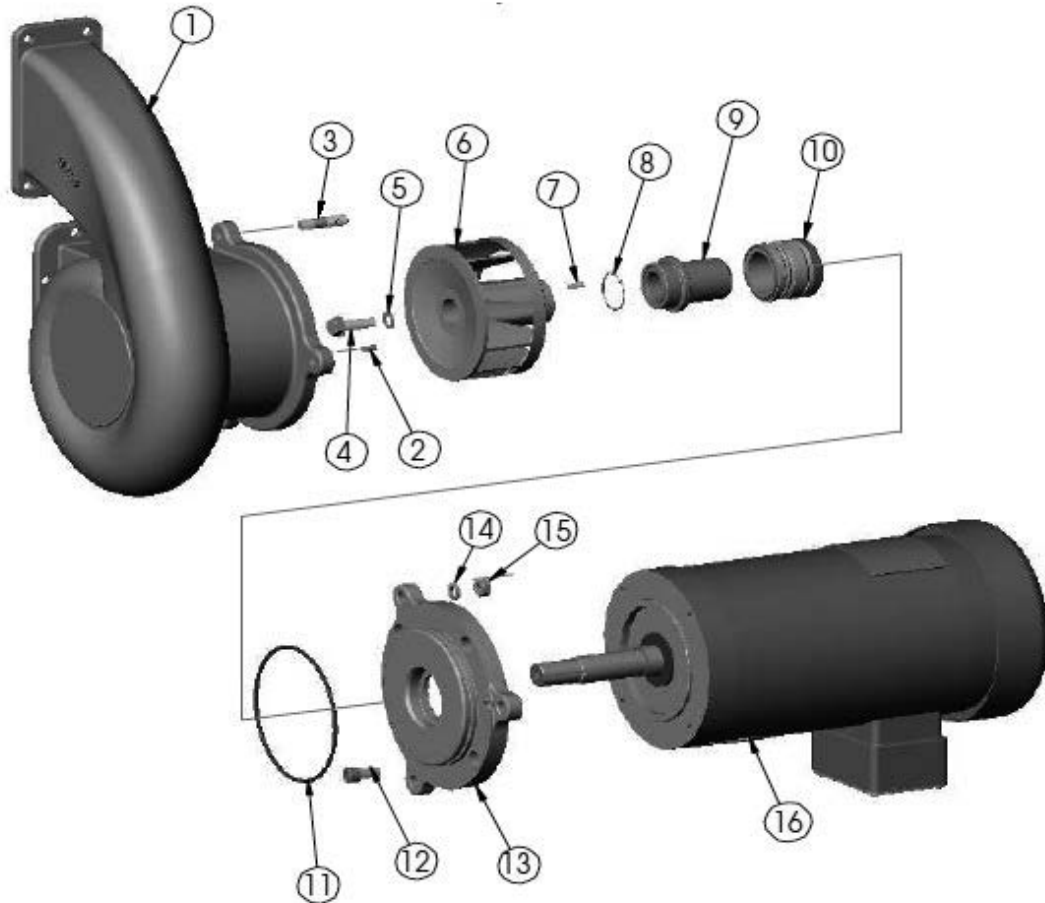

Item	Description
1	Casing
2	Cotter pin – part of casing
3	Stud – part of casing
4	* Impeller screw - 9/16" hex
5	* Impeller washer
6	Impeller
7	Impeller key
8	* Sleeve O-ring

Item	Description
9	Shaft Sleeve
10	* Mechanical Seal
11	* Adapter O-ring
12	Motor bolt – 5/16" allen
13	Adapter plate
14	Washer
15	Casing Nut – 9/16" hex
16	Motor

* Indicates parts included in the seal kit

Motor and Pump Assembly & Disassembly Procedures

DISASSEMBLY PROCEDURE:

- 1 Remove (3) nuts from the back of the adaptor plate. Slide the pump end out from the volute.
- 2 Holding the impeller to keep it from turning, loosen the washer head cap screw, and remove the screw and gasket.
- 3 Slide the impeller off of the shaft and remove the key.
- 4 Remove the seal/sleeve as a unit by pulling it off of the shaft. Some corrosion may prohibit movement and a lubricant may be used to penetrate between the sleeve and motor shaft. With the impeller and key removed, the shaft sleeve and the mechanical seal assembly can be removed.
- 5 Remove O-ring from the shaft sleeve.
- 6 With the shaft sleeve removed, the seal rotating assembly can be pulled off of the shaft sleeve.
- 7 Mark the adaptor plate and motor to insure proper re-assembly. Remove (4) screws from the adaptor plate. Take the adaptor plate off the motor.
- 8 Remove O-ring from adaptor plate.
- 9 With the adaptor plate removed, the seal seat can be removed using a screwdriver or by using your fingers.

INSPECTION OF THE COMPONENTS:

With pump end disassembled, clean all parts and check for worn and damaged areas. Worn or damaged metal parts should be replaced. The mechanical seal, gasket, O-ring, O-ring and washer head cap screw are replacement parts that are provided in the kit. All old parts must be discarded and are not to be reused.

ASSEMBLY PROCEDURE:

- 1 Push the mechanical seal seat squarely into the seal bore of the adaptor plate by using fingers. A little lube can be used on the seal bore of the adaptor plate. Make sure the ceramic side is up and it is fully seated.
- 2 Install the adaptor plate and tighten (4) screws, which hold it to the motor face. Make sure the marks made in step 7 above line up.
- 3 Install O-ring into the groove of the adaptor plate.

- 4 Coat the shaft sleeve lightly with lube. Install the mechanical seal on the shaft sleeve using your hand to push against the seal face. Make sure rubber seal bellows are seated against sleeve shoulder and carbon seal face is not scratched or chipped.
- 5 Slide the shaft sleeve onto the motor shaft and install the O-ring on the groove of the sleeve. Using lube or grease on the O-ring will help hold the ring in place temporarily until the impeller is secured.
- 6 Install the key on the motor shaft and place the impeller on the motor shaft engaging the key.
- 7 Put the gasket on the washer head cap screw.
- 8 Install the impeller cap screw by holding the impeller, push the impeller back against the sleeve and the other hand tighten the screw to 23-ft lbs. of torque. (Do not over tighten as this could cause the gasket to squeeze out, become deformed and not seal properly.)
- 9 Slide the pump end on the (3) studs of the volute. The motor junction box should be at the bottom.
- 10 Install (3) nuts on the stud and tighten to 23-ft.lbs.

Appendix A

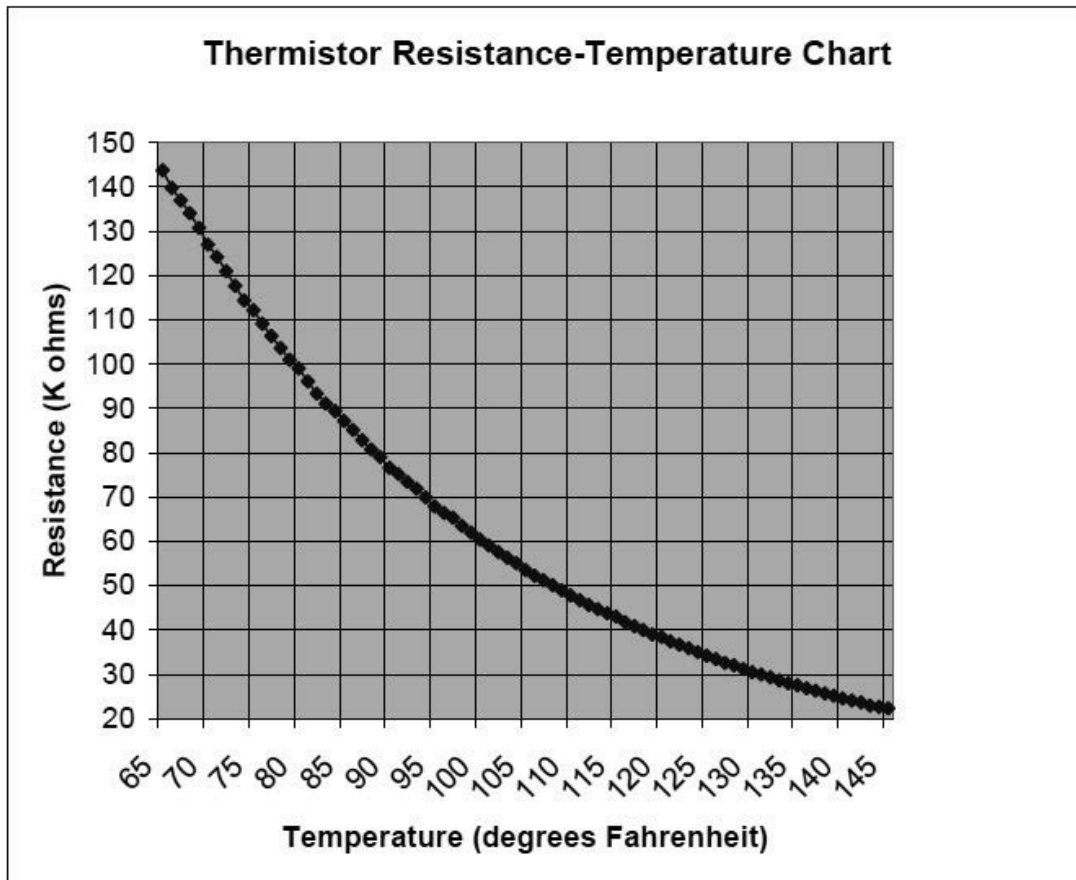

Power Soak[®]

Power Soak is a registered trademark of Cantrell Industries, Inc.
The Power Soak Design and concept is fully patented.

Power Soak Systems. Inc.
903 East 104th Street, Suite 130
Kansas City, MO 64131
Phone (816) 222-2400 Fax (816) 222-2419
(800) 444-9624
www.powersoak.com

Part#: 34773

Rev: - A

Rev Date: 12/19/13