

# **Power Soak<sup>®</sup>**

## Installation Manual

PS-225 & PS-275





# **Table of Contents**

<b>Pre-Uncrating Checklist .....</b>	<b>1</b>
<b>Verifying System Requirements .....</b>	<b>2</b>
Verifying System Direction .....	2
Verifying the Electrical Requirements .....	2
<b>Removal of Existing Unit .....</b>	<b>3</b>
Existing Supply Lines .....	3
Existing Sink Removal .....	3
Wall Preparation .....	3
<b>Pre-Plumbing .....</b>	<b>4</b>
Supply and Waste Lines .....	4
Grease Trap .....	4
<b>Post-Uncrating Instructions .....</b>	<b>5</b>
<b>Uncrating .....</b>	<b>6</b>
Remove From Crate .....	6
<b>Component Installation .....</b>	<b>7</b>
Install Sink Drains .....	7
Install Legs .....	10
<b>JBZ Joint Installation .....</b>	<b>12</b>
Test Fit .....	12
Mating and Sealing the Joint .....	12
<b>Wiring Connections .....</b>	<b>14</b>
Machine Wiring .....	14
Optional Wireless Remote Alert Light System .....	14
Optional Water-Tight Disconnect Box with Switch .....	14
Optional Chemical Dispenser Wiring .....	15
Faucet Installation .....	16
<b>Completing the Installation .....</b>	<b>17</b>
<b>Final Installation Steps .....</b>	<b>18</b>
Machine Placement .....	18
Downturned-Backsplash Z-Clip Installation .....	18
Upturned-Backsplash Level Attach to the Wall .....	18
Seal around the Backsplash and Screws .....	19
Rinse Riser and Anchor Installation .....	19

Plumbing Connections .....	20
Electrical Connections .....	20
Checking the Motor Rotation (“JOG” Feature) .....	20
Shelving .....	21
<b>Validating the Installation .....</b>	<b>23</b>
<b>Testing the Components .....</b>	<b>24</b>
Check for Leaks .....	24
Check the Electrical Installation .....	24
Check Operation .....	24
Check the Chemical Dispensing System .....	24
<b>Appendix.....</b>	<b>25</b>

# **Power Soak<sup>®</sup>**

## Pre-Uncrating Checklist

PS-225 & PS-275



# Verifying System Requirements

Prior to completely removing the Power Soak unit from the crate, it is necessary to verify certain requirements. Remove only the lid of the crate at this time.

## Verifying System Direction

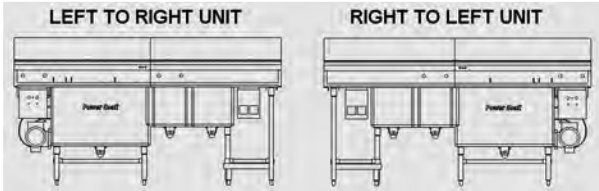

The Power Soak can be built as a “Left to Right” or as a “Right to Left” configuration with a variety of options. Look inside the crate and verify that the configuration of the machine matches the specifications of the order description.

## Verifying the Electrical Requirements



The electrical requirements for the machine are on the machine identification tag located on the side of the wash tank, next to the motor. The electrical service in the facility where the machine is to be installed must be rated for the capacity shown on the identification tag. This machine will require a permanently mounted disconnect that is in a “liquid tight” enclosure. Do not use an in-line plug for disconnecting the machine from the electrical source. Contact a licensed and certified electrician to make the enclosure installation if one is not present. Use the tables in the appendix to determine the appropriate breaker (overcurrent protection) and wire size for the machine’s electrical service.

### **IMPORTANT**

**WARNING:** DO NOT connect the machine using a power cord and plug or an extension cord of any kind.

**WARNING:** Kitchens are a wet environment which require all electrical connections to be “liquid tight”.

Electrical installation must conform to all applicable local wiring codes. All electrical connections must be “liquid tight” and readily accessible for inspection after installation without moving the Power Soak machine or any of its accessories.

## Removal of Existing Unit

If the new Power Soak is not replacing an existing sink, skip this section. If the removal of an existing sink is necessary, continue with this section.

### Existing Supply Lines

The water and electrical source must be shut off before disconnecting or cutting the water or electric lines.

#### **WARNING**

Failure to shut off the electrical and water supply will result in personal injury, including serious injury or death, and extensive equipment damage.

Disconnect any electrical cord that is connected to the existing sink. Cut the cold and hot water lines as closely as possible to the fittings on the existing sink.

#### **IMPORTANT**

Be sure to leave enough of the existing piping for the installation of new shutoff valves. See "Pre-Plumbing" section for reference.

### Existing Sink Removal

Detach any fasteners holding the existing sink in place and remove the existing sink along with any shelves that may interfere with the installation of the Power Soak. Discard all unwanted materials in an appropriate container or disposal area.

### Wall Preparation

Clean the wall(s) where the new Power Soak will be installed. Fill all existing holes with an appropriate filler material. Be sure that any outlet that will be covered by the sink has been disconnected and a water tight cover has been installed over the opening.

# Pre-Plumbing

## Supply and Waste Lines

The supply and waste lines must meet the following requirements:

- Hot and cold water supply must be 1/2" diameter or larger.
- Center lines of the hot and cold water supply must be 10" or less above the floor to access the shutoff valves when the machine is installed.
- Waist drain must be 1-1/2" minimum diameter.
- Center line of the waste drain must be 11" or less above the floor to allow the sink to drain properly.

Install new shutoff valves on the hot and cold water supply lines.

### IMPORTANT

IT IS RECOMMENDED THAT ALL MACHINES BE INSTALLED USING NEW 1/2" OR LARGER BALL-VALVE SHUT OFF VALVES.

## Grease Trap

It may be necessary to relocate and/or replace the existing grease trap. Be sure that the grease trap meets or exceeds the local plumbing codes.

### IMPORTANT

WASTE PLUMBING MUST CONFORM TO LOCAL BUILDING CODES.



# **Power Soak<sup>®</sup>**

## Post-Uncrating Instructions

PS-225 & PS-275



# Uncrating

## Remove From Crate

Remove the Power Soak from the shipping crate. Sharp staples and nails are used to crate the machine and care must be taken in handling boards and cardboard to keep from creating a puncture or injury to people or the equipment. Discard the crating materials in an appropriate disposal area or container.

Inspect the sink and packages to be certain that there was no damage created by the shipping company. If there are signs of shipping damage, contact the shipping company before proceeding.

Remove the packages from the Power Soak tank and locate the box labeled "OPEN FIRST". This box will contain the fasteners and sealant that will be required for assembly of the Power Soak.



Locate the box labeled "OPEN FIRST" to find fasteners and sealant used for the installation.

## Component Installation

Lay the sink on its back to allow access to the bottom of the tanks. Be careful to not let the sink assembly drop on the floor with an impact that would damage the sink assembly or the floor. It may be necessary to place some cardboard or tarp on the floor to protect the finish.



### IMPORTANT

Do not bend the edge of the backsplash when laying the sink on its back side.

DRAIN WITH BUILT-IN VALVE IS INSTALLED IN THE BOTTOM OF THE TANK

The sink must be accessible from its top side and its bottom side in order to install the accessories. Be aware that the backsplash is unsupported at this time and can be bent out of shape by trying to support the entire weight of the sink on the edge of the backsplash.

## Install Sink Drains

There are three sink drains in the Power Soak that must be installed. The drain with a valve built into the body is installed in the bottom of the tank and oriented with the drain valve handle toward the front of the sink. Each drain flange must be sealed to its mating surface in the sink.

Apply a generous bead of a drain sealant around the lip of the drain body.



**IMPORTANT**

THE RIM OF THE DRAIN MUST SEAT ON THE SURFACE OF THE SINK OR IT WILL WORK LOOSE OVER TIME AND ALLOW WATER TO LEAK AROUND THE DRAIN

The drains with built-in valves will be oriented with the handle connection toward the front of the sink. From inside the sink, insert the drain through the drain hole and seat the flange against the sheet metal surface of the tank. Be sure that the sealant compresses to where the rim of the drain actually touches the sheet metal surface of the sink. If the drain does not touch the sink it will work loose and leak as the sealant compresses over time.

From the outside of the tank place the rubber vibration ring over the threaded body of the drain followed by the Teflon ring and then the drain nut. Tighten the nut "hand tight" until the handle is installed.

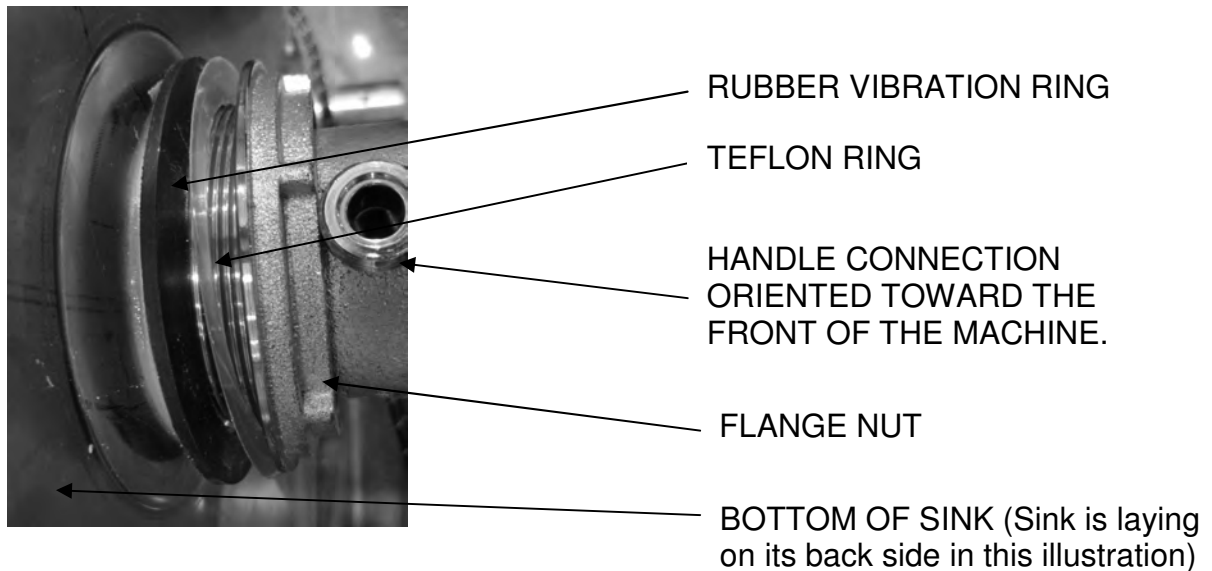

Using two nuts, attach the drain handle bracket to the studs on the bottom of the tank. Insert the drain valve handle through the bracket and into the drain body. It may be necessary to rotate the handle a partial turn to align the flats on the end of the handle shaft with the flats on the valve so that the handle will fully insert into the valve. Secure the handle to the valve body by screwing the handle nut onto the valve body connection.

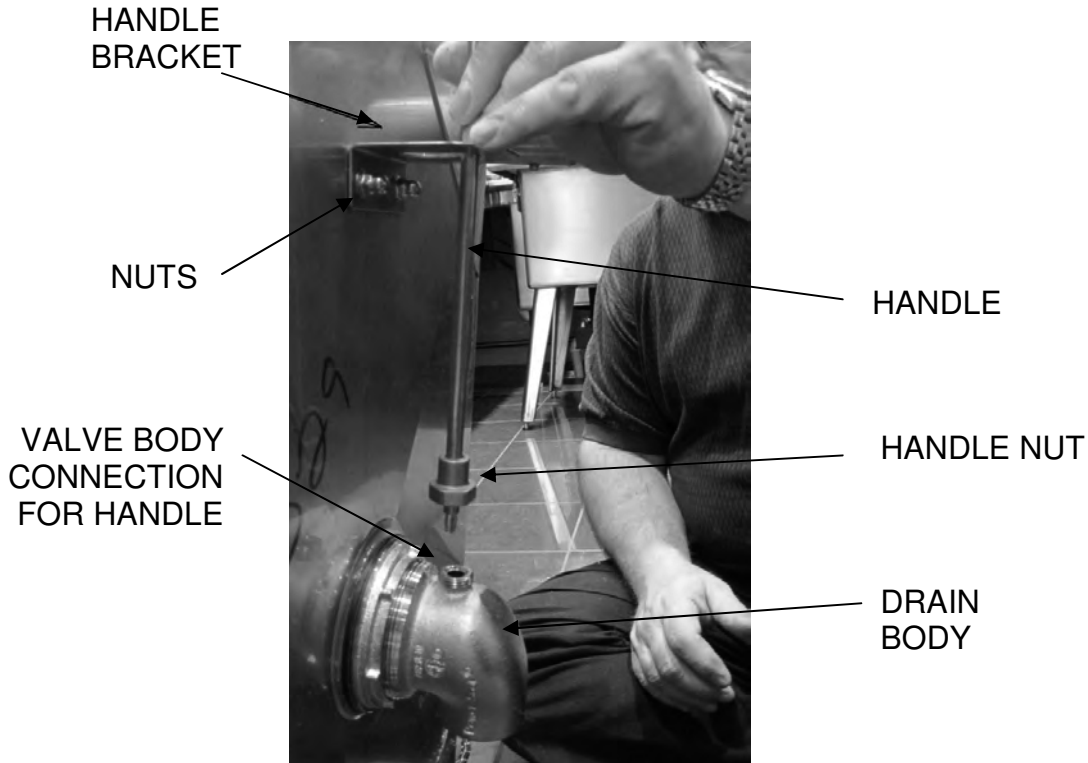

While holding the drain body to prevent it from rotating, tighten the flange nut with a wrench to firmly seat the nut against the rubber vibration ring and the vibration ring against the surface of the sink (approximately  $\frac{1}{4}$  turn past "hand tight"). Wipe or trim the excess sealant from around the drain flange inside the sink. Allow the sealant to dry before filling the sink with water (see instructions on the side of the sealant container for drying time). After the sealant has dried, fill the sink with water and check for leaks around the drain.

## Install Legs

The Power Soak is usually shipped without the leg assembly attached to the machine. Different options have different types of leg assemblies. Some leg assemblies are all welded together and others are pieces that need to be assembled. If the leg set is welded together, skip to the section labeled “Leg Set and Sink”.

### Leg Set Assembly

Locate the two leg end weldments and stretcher. The stretcher is the horizontal tube that connects between the legs to provide lateral stability to the legs. The long stretcher will be installed between the back legs of the wash tank.

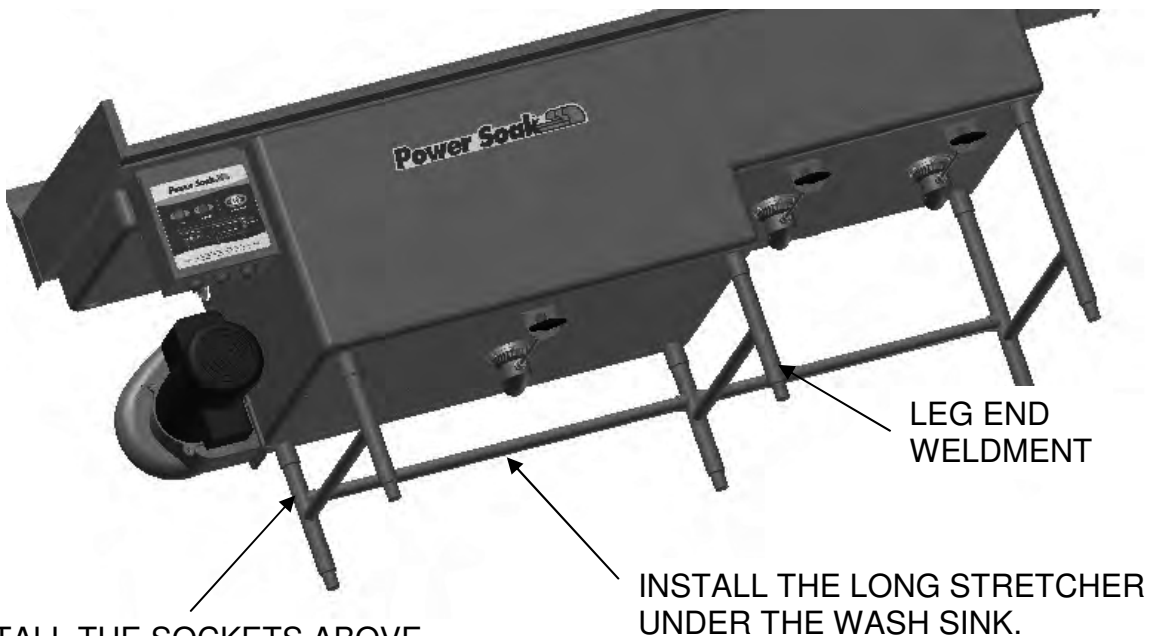

INSTALL THE SOCKETS ABOVE THE WELD JOINT PRIOR TO INSERTING THE LEG WELDMENT INTO THE SOCKETS ON THE BOTTOM OF THE SINK.

INSTALL THE LONG STRETCHER UNDER THE WASH SINK.

Orient the stretcher socket with the set screw facing toward the interior of the sink and then slide the stretcher sockets over the top of the leg sets so that the stretcher will be positioned above the welded joint of the leg when the legs are assembled onto the sink. Install the long stretcher and the other stretcher between the leg sets by inserting it into the sockets **before** inserting the legs into the sockets on the bottom of the tanks.



SET SCREWS ARE ORIENTED TOWARD THE INTERIOR OF THE SINK AND THE SOCKET IS ON TOP OF THE WELDED STRETCHER

WELDED STRETCHER

### Leg Set and Sink

Insert the leg assembly into the sockets on the bottom of the sink. Insert the leg set into the sanitizer sink (sanitizer sink is an option and may not be included). Be sure that all the legs are seated in the bottom of the sockets. Use an allen wrench (5/32) to tighten the set screws in all of the sockets. After tightening the set screws, apply silicone sealant (supplied with the machine) to the set screw openings in order to seal the openings in a clean and sanitary manner.

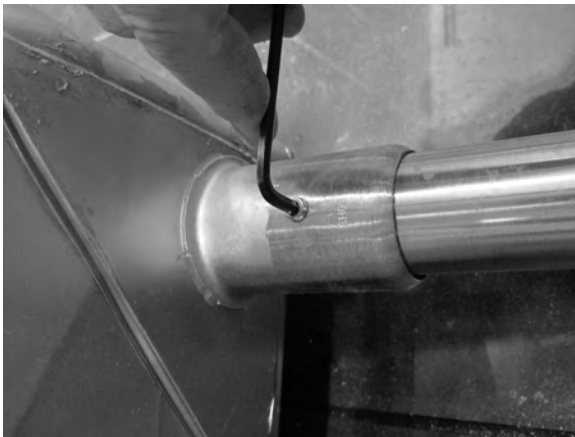

### IMPORTANT

AFTER TIGHTENING THE SET SCREWS, FILL THE OPENINGS IN A CLEAN AND SANITARY MANNER WITH THE SILICONE SEALANT THAT IS SUPPLIED WITH THE MACHINE

### Adjusting the Feet

Use a tape measure and adjust the feet to the approximate height required. Turn the hexagon foot clockwise to shorten the height of the sink or counterclockwise to raise the height of the sink. Final adjustment of the feet will be done after the sink is in the installed location. Set the sink and leg assembly upright on its feet.

# JBZ Joint Installation

If the unit is shipped in one piece, skip this section. If the unit is shipped as two separate pieces, continue with this section.

## Test Fit

Dry fit the two sections of the sink together to be sure that the joint has not been damaged in shipping. The lip of the rinse tank will slide over the edge of the wash tank.

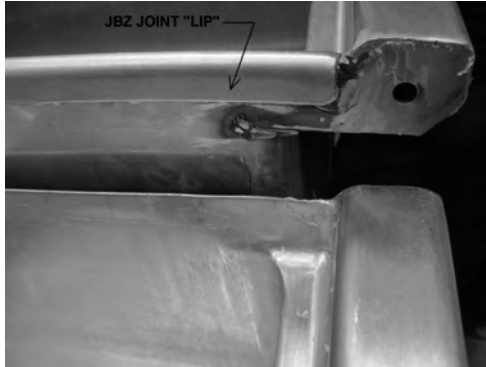

Check the alignment and fit of the two sections. It may be necessary to adjust the leveling feet to achieve a correct fit. Ensure that all the feet are adjusted to firmly contact the floor.

Separate the two sections in order to apply sealant to the joint.

## Mating and Sealing the Joint

Apply the **grey-colored** NSF approved sealant (supplied with the unit) to the underside of the JBZ lip and all interior surfaces of the wash tank trim plate.

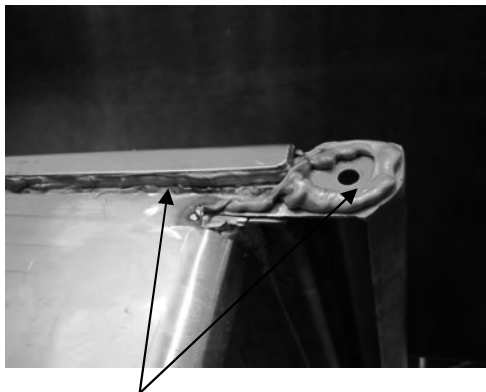

SEALANT APPLIED TO  
UNDERSIDE OF JBZ JOINT AND  
FACE OF THE END PLATE

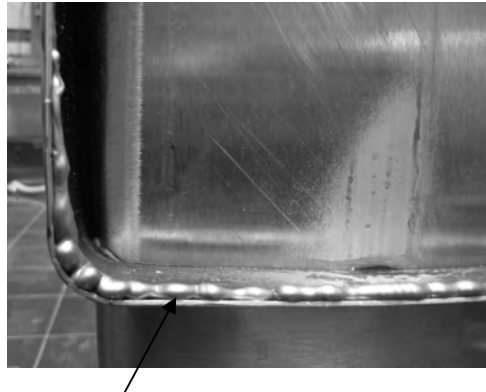

SEALANT APPLIED TO INTERIOR  
SURFACE OF TRIM PLATE



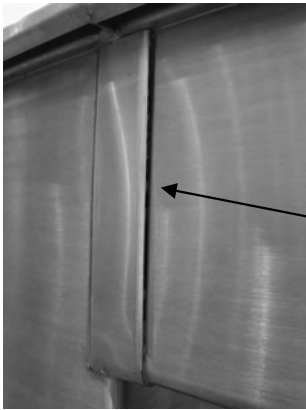

Reassemble the two sections. Apply a bead of **grey-colored** NSF approved sealant (supplied with the unit) in the gap between the rinse sink and the trim plate. Seal the entire joint to keep liquids from entering.

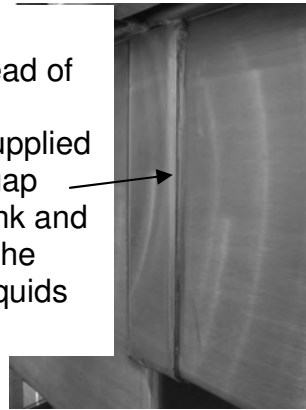

Bolt the channel rim and backsplash together using the nuts and bolts provided with the unit.



**BOLT THE JOINT TOGETHER UNDER THE FRONT RIM AND BEHIND THE BACK SPLASH.**



Seal the backsplash, channel rim, and all the gaps between the two sinks with the **grey-colored** NSF approved sealant that is supplied with the unit.

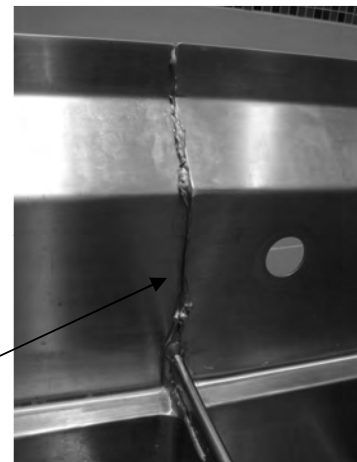

**APPLY THE GREY-COLORED NSF APPROVED SEALANT TO ALL THE SINK JOINTS AND WIPE THE EXCESS AWAY LEAVING A SMOOTH SANITARY JOINT.**

# Wiring Connections

## Machine Wiring

Locate the two halves of the wiring harness and inspect them to be sure they are clean and not damaged. Insert the two halves together and hand tighten the threaded collar.



HAND  
TIGHTEN  
THE COLLAR



## Optional Wireless Remote Alert Light System

If the Power Soak unit was purchased with the Wireless Remote Alert Light System, refer to the instructions provided with the light system to complete the wiring for this device.

## Optional Water-Tight Disconnect Box with Switch

If the Power Soak unit is purchased with a Water-Tight Disconnect Box with Switch system, refer to instructions supplied with the disconnect box to complete wiring for this device. If instructions are not followed the warranty will be voided.

## Optional Chemical Dispenser Wiring



If installing any chemical dispensing system that is **not** a Power Soak® brand chemical dispenser, follow the manufacturer's installation guide, and skip this section.

If the unit being installed is supplied with the optional Power Soak® brand chemical dispenser, proceed with this section.

Power Soak® brand chemical dispenser is shown here

The Power Soak® chemical dispensing unit must be bolted to the underside of the front rim and have the electrical connector attached to the back of the chemical dispenser enclosure. The chemical delivery hoses must be installed from the dispenser to the wash tank and sanitizer tank chemical injectors. The hoses may follow along the wire harness and loosely hung with zip-type wire ties.



### IMPORTANT

The chemical supplier must finalize the setup of the chemical dispensing system.

## Faucet Installation

Open the faucet package and locate the water connection elbows, faucet body and escutcheon assemblies. Apply Teflon tape to the threads of the elbows and insert them through the backsplash of the sink.



Loosely fit the escutcheons to the elbows and the faucet body. When the alignment of the body with the sink is confirmed, tighten the escutcheons onto the elbows and faucet body. From the back side of the backsplash, tighten the brass nuts on the elbows when the faucet body is parallel with the rim of the sink.

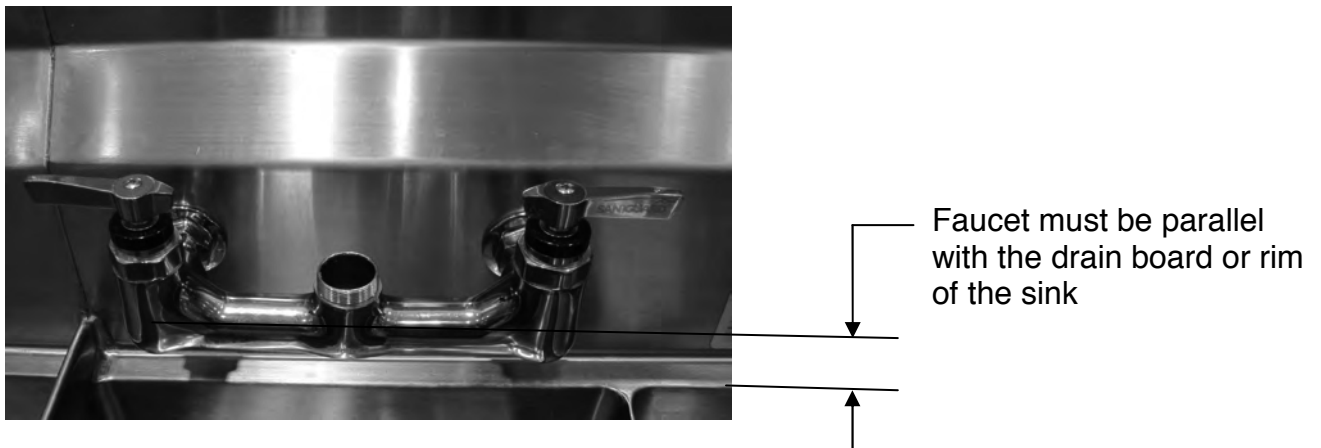

Complete the faucet assembly according to the manufacturer's instructions which are included with the faucet. Attach water lines to the faucet so that the lines extend below the sink. This will make the plumbing easier to complete when the machine is placed against the wall.

# **Power Soak<sup>®</sup>**

## Completing the Installation

### PS-225 & PS-275



# Final Installation Steps

## Machine Placement

Position the Power Soak so that the back splash rests against the wall and is placed according to the floor plan or customer's selected location. Examine the drain and water supply lines to determine that the plumbing can be completed when the Power Soak is in the final location. Verify that the plumbing from the faucet can be reached with the sink against the wall.

## Downturned-Backsplash Z-Clip Installation

If the Power Soak® system has an upturned backsplash, skip this step.

If the Power Soak® system has a backsplash that is downturned, attach the provided Z-Clips to the wall using the following procedure. Using a level, adjust the feet on the Power Soak until the front rim and the rear rim of the sink are level. The sink must also be level front to back. Measure from the floor to the top edge of the backsplash, and then move the sink away from the wall. Locate Z-Clips by marking a level line on the wall approximately 1/16" to 3/32" below the height of the backsplash top edge. Locate the wall studs and mark the locations. Align top edge of Z-Clip(s) to the marked line and securely fasten the Z-Clips to the wall, using fasteners provided. Install screws directly to the walls' studs whenever possible. The Z-Clips should be space as evenly as possible. Move the sink to the wall and lift the back edge over the Z-Clips.

## Upturned-Backsplash Level Attach to the Wall

If the Power Soak® system has a downturned backsplash, skip this step.

Using a level, adjust the feet on the Power Soak until the front rim and the rear rim of the sink are level. The sink must also be level front to back. Locate the wall studs and mark their location on the top edge of the back splash. Measure down 3/4" from the top of the backsplash and then drill 1/4" diameter holes through the back splash in line with the center of the studs. Use the #10 stainless steel screws (included with the Power Soak) to attach the Power soak directly to the wall.

### IMPORTANT

**The Power Soak sink assembly must be level from side to side and front to rear with all the feet making firm contact with the floor.**

## Seal around the Backsplash and Screws

Examine the installation to see that the wall and backsplash are clean and free of dust and oils. Seal the top and sides of the backsplash to the wall using the clear NSF approved sealant provided with the Power Soak. Seal around the screw heads to be sure they do not allow water to leak behind the backsplash. Wipe off all excess sealant leaving a smooth, clean and sanitary bead of sealant on all the edges.

## Rinse Riser and Anchor Installation

Follow the faucet manufacturer's directions on the assembly of the faucet and riser. Anchor the riser supports to the wall using the flange plate provided with the riser assembly. It may be necessary to cut the support rods to a shorter length in order to fit between the wall and the riser.

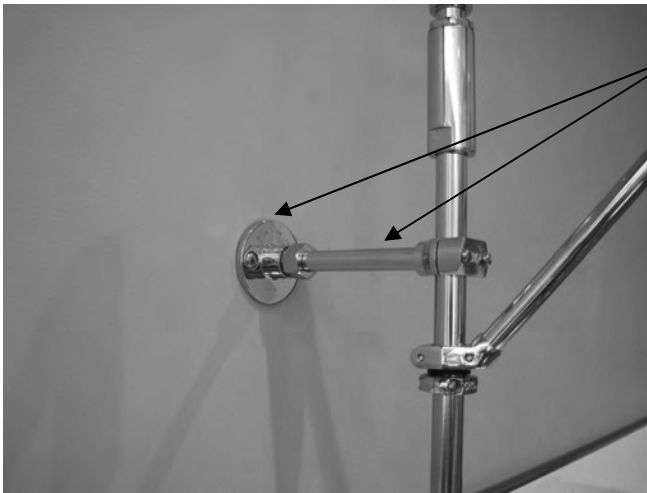

Cut the riser support rods to the proper length and attach flanges to the wall

## Plumbing Connections

Connect the water supply lines to the faucet. Connect all the drains to the waste drain connection.

DO NOT USE HOSES to make the pressure connections to the faucets. Maximum water inlet pressure is not to exceed 125 psi (8.6 Bar), minimum water pressure to be not less than 20 psi (1.2 Bar).

### IMPORTANT

**INSTALLER IS RESPONSIBLE FOR ALL PLUMBING TO CONFORM TO LOCAL BUILDING CODES WHICH MAY BE DIFFERENT FROM ILLUSTRATIONS SHOWN IN THIS MANUAL**

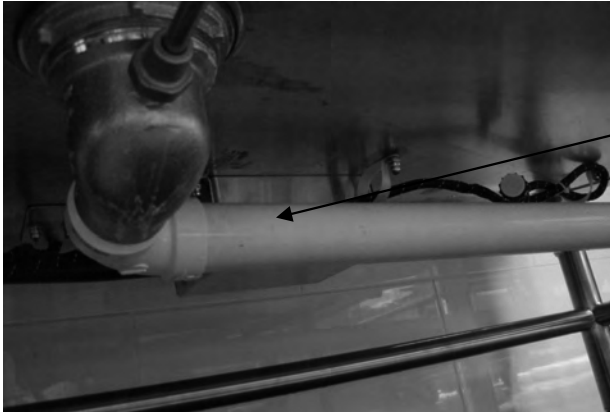

Complete the connection of all drains and water supply lines

## Electrical Connections

The final electrical connections between the Power Soak and the electrical supply must be made by a licensed electrician. The Power Soak has several options for motors and heater. Review the information tag for determining the specific requirements of the machine being installed (see Verify the Electric Requirements section of this instruction booklet).

An equipotential bonding terminal is provided on the side of the wash tank and identified with the symbol shown at the right of this statement. This terminal is used to make a connection for properly grounding the machine. This connection must be completed by a qualified electrical technician.



Symbol for Bonding Terminal

## Checking the Motor Rotation (“JOG” Feature)

The motor must rotate in the correct direction in order for the Power Soak to function properly. An arrow indicating the direction of rotation is located on the pump housing. The control unit has a feature that allows the motor to be “jogged” for checking the rotation even if the wash tank is empty.



Press and hold the green START button for 5 to 10 seconds and watch the fan blades inside the motor fan cover. After holding the start button for the 5 to 10 second delay, the motor will start for a few rotations and automatically stop if the wash tank is empty. If the wash tank is full of water the motor will continue to run even if the direction of rotation is not correct. When the wash tank is full, the red STOP button must be pressed to stop the motor. Running the motor in the wrong direction does not damage the motor or pump, but the pump will not circulate water in the wash tank correctly.



**IMPORTANT**

**THE MOTOR MUST ROTATE IN THE CORRECT DIRECTION FOR THE MACHINE TO OPERATE PROPERLY. USE THE “JOG” FEATURE TO CHECK THE MOTOR ROTATION**

## Shelving

Reinstall any shelving that was removed for convenience of installation. If the shelving is damaged or corroded, it is recommended that the shelving be replaced.

Intentionally blank page

# Power Soak<sup>®</sup>

## Validating the Installation

### PS-225 & PS-275



# Testing the Components

## Check for Leaks

- Turn on the water supply and inspect all joints for leaks.
- Close the drain valve(s), fill the sink(s) with water and inspect the drain fittings for leaks.
- Open the drain valve(s) and inspect the drain joins for leaks as the water is draining from the sink.

## Check the Electrical Installation

- Verify that there are no loose wires or open electrical enclosure.
- Fill the wash tank with water and press the START button to see that the motor will start. Have a qualified electrician verify that the amp draw on the electrical supply is within the specifications on the identification tag.
- Check motor rotation for the correct direction as indicated by the arrow on the pump housing.

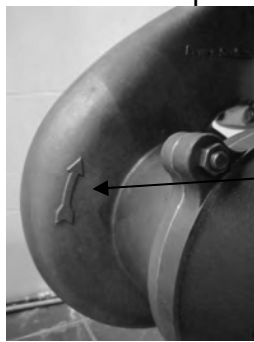

Direction of rotation arrow

**IMPORTANT**

**MOTOR ROTATION  
MUST BE THE  
CORRECT DIRECTION  
FOR THE MACHINE TO  
OPERATE CORRECTLY**

## Check Operation

- Open each faucet knob and verify that water flows from each hand control. Verify that hot and cold water are running from the correct hand control.
- With the water valves open, turn the center knob to see that it will shut off flow to the faucet and that the hand sprayer is still functional.

## Check the Chemical Dispensing System

The Chemical Dispensing System must be checked by a representative of the manufacturer. It will need to be verified that the proper amount of chemical is being dispensed and that the proper chemical concentration is maintained during operation.

## Appendix

### **Power Soak<sup>®</sup> Systems with Heaters**

HP	Phase	Hz	System Voltage	Minimum Supply Conductor (AWG)	Minimum Overcurrent Protective Device (Amps)
2	1	60	208	8	50
2	3	60	208	10	30
3	3	60	208	8	40
2	1	60	230	8	50
2	3	60	230	10	30
3	3	60	230	8	40
2	3	60	480	14	15
3	3	60	480	12	20
2	1	50	220	8	50
2	3	50	380	10	30
3	3	50	380	10	30

### **Power Soak<sup>®</sup> Systems without Heaters**

HP	Phase	Hz	System Voltage	Minimum Supply Conductor (AWG)	Minimum Overcurrent Protective Device (Amps)
2	1	60	208	14	15
2	3	60	208	14	15
3	3	60	208	14	15
2	1	60	230	14	15
2	3	60	230	14	15
3	3	60	230	14	15
2	3	60	480	14	15
3	3	60	480	14	15
2	1	50	220	14	15
2	3	50	380	14	15
3	3	50	380	14	15

# Electric Wiring Diagram – Single Phase

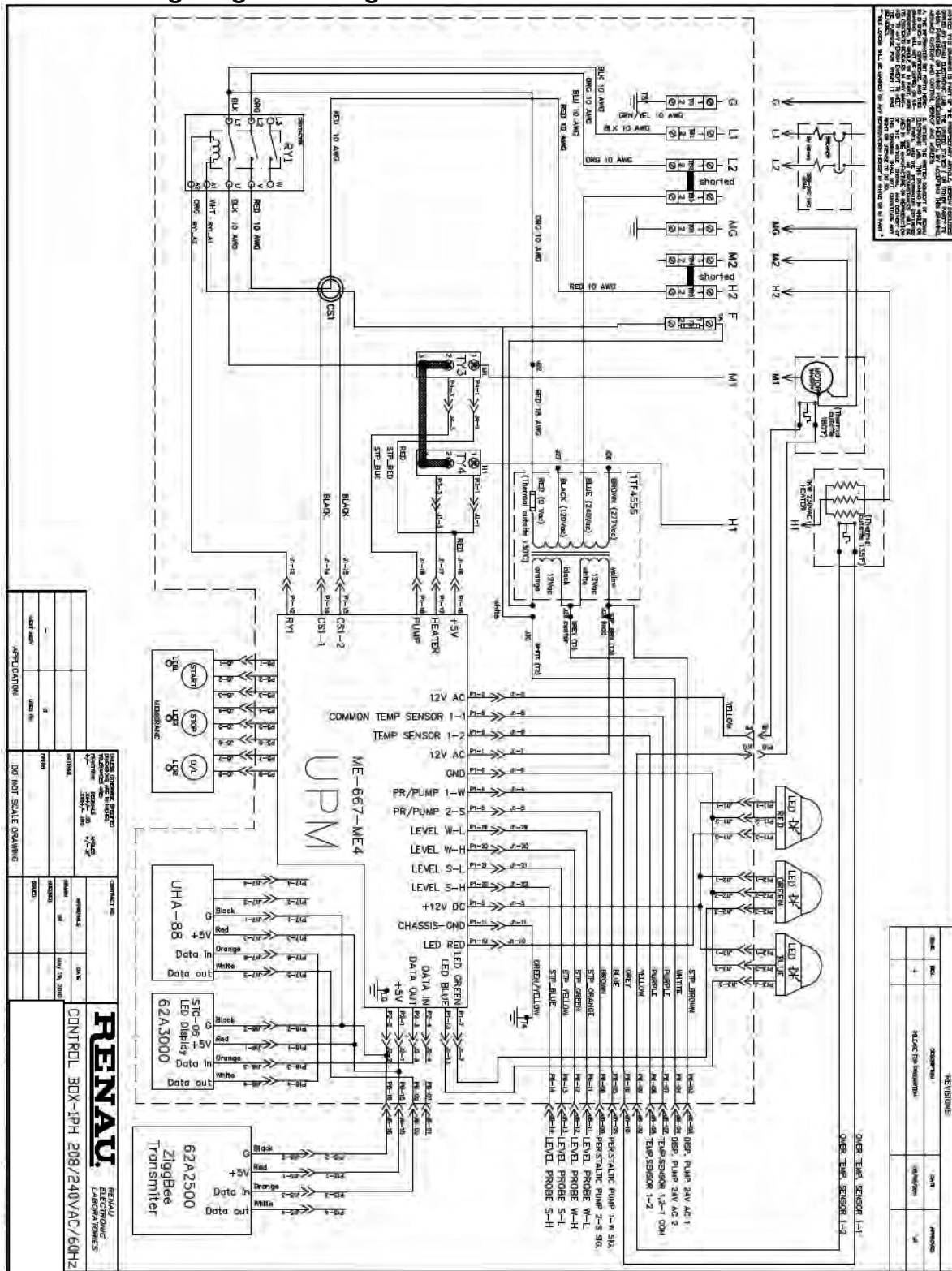

# Electric Wiring Diagram – 3 Phase

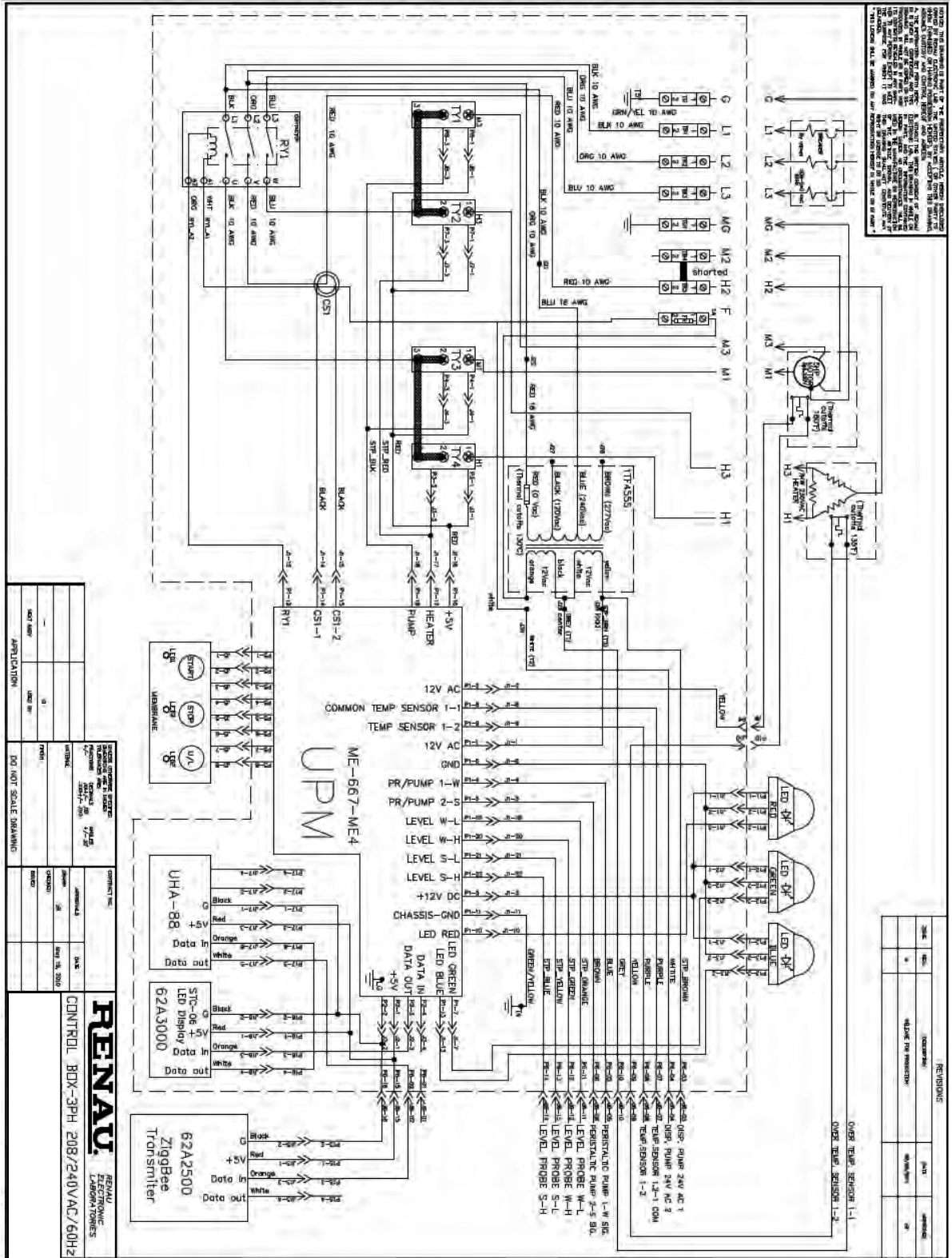

# **Power Soak<sup>®</sup>**

Power Soak is a registered trademark of Cantrell Industries, Inc.  
The Power Soak concept and design is fully patented.

[www.unifiedbrands.net](http://www.unifiedbrands.net)

Part#: 34453

Rev: E

Rev Date: 9/20/16