

# **Power Soak<sup>®</sup>**

## **Owner's Manual**

**PS-225**

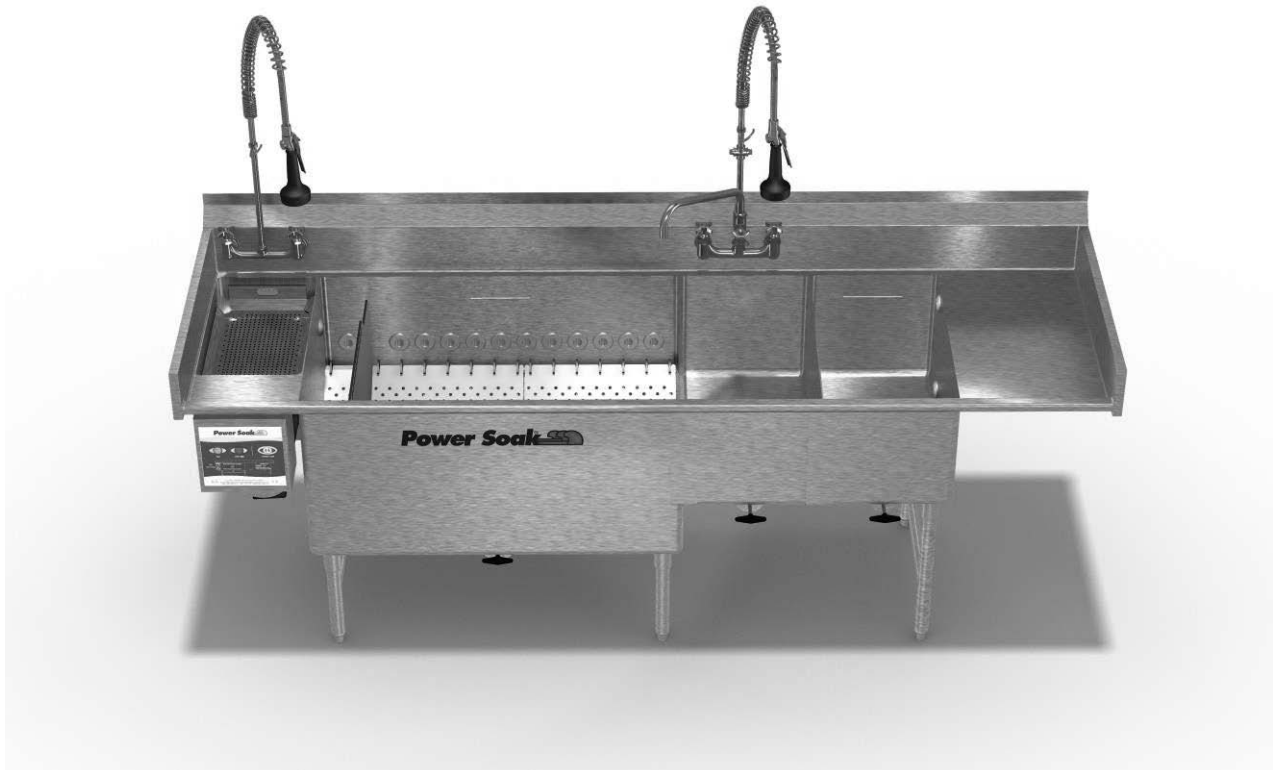

This Page Left Intentionally Blank

# Table of Contents

|  |    |
|--|----|
| Introduction and Conventions.....                | 1  |
| Product Introduction .....                       | 2  |
| Explanation of Warning Messages.....             | 3  |
| Personal Injury and Property Damage Hazard ..... | 3  |
| Property Damage Hazard.....                      | 3  |
| Chemical Hazard.....                             | 3  |
| Personal Injury Hazard.....                      | 3  |
| Requirements for Detergents and Sanitizers ..... | 4  |
| Detergents.....                                  | 4  |
| Sanitizers.....                                  | 4  |
| Power Soak Service Assistance.....               | 4  |
| Operating Instructions .....                     | 5  |
| Panel Front Controls and Features .....          | 6  |
| START Button .....                               | 6  |
| STOP/IDLE Button .....                           | 6  |
| UNLOAD/LOAD Button .....                         | 6  |
| UNLOAD/LOAD Light.....                           | 7  |
| STATUS Light .....                               | 7  |
| WASH TANK Light .....                            | 7  |
| SANITIZER TANK Light .....                       | 7  |
| Indirect Beacon System .....                     | 8  |
| Blue Beacon .....                                | 8  |
| Green Beacon .....                               | 8  |
| Red Beacon.....                                  | 8  |
| Preparing the System.....                        | 9  |
| Filling the System .....                         | 9  |
| Wash Fluid .....                                 | 9  |
| Rinse Water.....                                 | 10 |
| Sanitizer Water .....                            | 10 |
| Adding Detergents & Sanitizers.....              | 11 |

|  |           |
|--|-----------|
| Operating the Power Soak .....                   | 12        |
| Starting and Stopping the Wash Action.....       | 12        |
| Introducing Pots and Pans to the Power Soak..... | 12        |
| Properly Scrapping Pots and Pans .....           | 12        |
| Loading and Using the Wash Tank .....            | 12        |
| Unload/Load.....                                 | 13        |
| Rinsing Pots and Pans.....                       | 15        |
| Sanitizing Pots & Pans.....                      | 15        |
| Drying of Pots & Pans .....                      | 15        |
| Deep Cleaning and "Night Washing".....           | 16        |
| Changing the Wash Solution.....                  | 17        |
| Changing the Sanitizer Solution .....            | 17        |
| Wash, Rinse and Sanitizer Clean-Up.....          | 18        |
| <b>Preventative Maintenance .....</b>            | <b>19</b> |
| Daily .....                                      | 20        |
| Monthly.....                                     | 20        |
| As needed.....                                   | 20        |
| <b>Troubleshooting.....</b>                      | <b>22</b> |
| <b>Facility Owner/Manager Section .....</b>      | <b>23</b> |
| <b>Authorized Service Agency Section .....</b>   | <b>24</b> |
| Explanation of LED Sequence .....                | 24        |
| Wash Pump/Heater Will not Operate .....          | 25        |
| <b>Installation .....</b>                        | <b>28</b> |
| Electrical Requirements .....                    | 29        |
| Plumbing Requirements.....                       | 30        |
| <b>Decommissioning.....</b>                      | <b>31</b> |

# Power Soak<sup>®</sup>

## Introduction and Conventions

PS-225

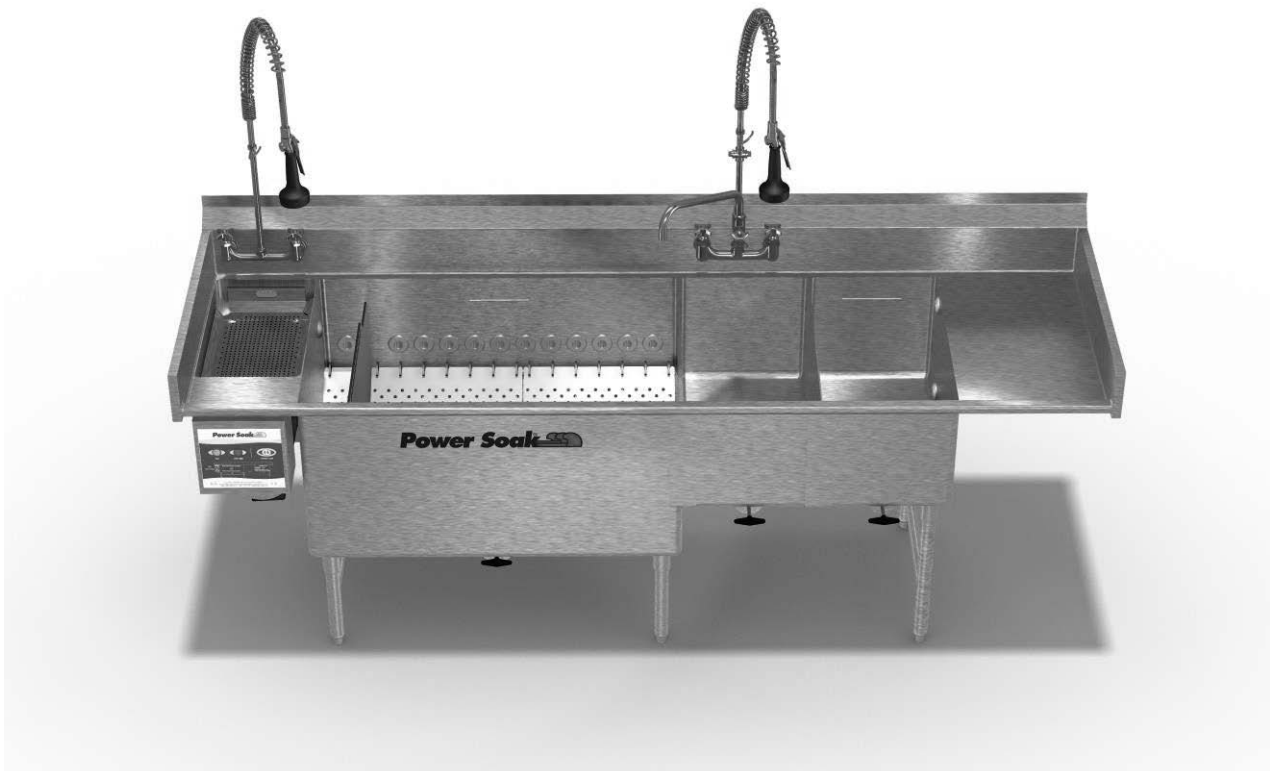

# Product Introduction

Thank you for purchasing a Power Soak ware washing system.

Your new Power Soak pot, pan and utensil washing system will provide years of dependable, efficient and trouble-free service.

As a Power Soak owner, you will benefit in numerous ways:





- Your ware washing operation will be more efficient.
- Pots, pans and utensils will be cleaner.
- The overall level of sanitation in your scullery area will improve.
- Ware washing hours will decrease as employee morale increases.
- Chemical and water usage will decrease.

Every system is manufactured to last, with only high-quality, heavy-duty, 14 gauge stainless steel used in its construction. All electrical components used in a Power Soak system are of the highest quality. The faucets and drains are designed for quick filling and emptying of the system's tanks.

At Power Soak Systems, we take pride in manufacturing the Power Soak line and are committed to standing behind our customers and products 100%. Should you ever need assistance, please contact us directly at the factory by dialing 800-444-9624 or fax: 816-761-0544.

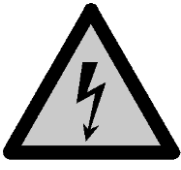
# Explanation of Warning Messages

Be sure to read, understand and follow all DANGER, WARNING, and CAUTION messages located in this guide and on the equipment.

|   |   |
|---|---|
| <p><b>Personal Injury and Property Damage Hazard</b><br/>Will result in serious injury or death.<br/>Will cause extensive equipment damage.</p>   |    |
| <p><b>Property Damage Hazard</b><br/>Will result in property or equipment damage</p>  |    |
| <p><b>Chemical Hazard</b><br/>Will result in serious injury or death. Instructions, labels and Material Safety Data Sheets (MSDSs) should be supplied with all detergents and sanitizing chemicals. The manufacturers, importers and distributors of the cleaning chemicals are responsible for providing this information.</p> |   |
| <p><b>Personal Injury Hazard</b><br/>Hazard from sharp objects, scalding, falling and/or drowning.<br/>Will result in serious injury or death.</p>  |  |

Children must not be allowed to play in the sinks, on countertops or with the controls of the Power Soak equipment. Cleaning or use of this machine must not be done by children without supervision. This machine can be used by children aged 8 years or above and by persons with reduced physical, sensory or mental capabilities or lack of experience and knowledge if they are given supervision and instruction concerning use of the appliance in a safe way and understand the hazards involved. There is a potential of drowning for any person whose head becomes submerged in the fluid contained in the sinks along with other hazards identified in this manual.

# Requirements for Detergents and Sanitizers

## Detergents

Remember, improper detergents may damage equipment! Use of the correct detergent in your Power Soak system is critical to its washing performance. If you are having problems with cleaning results, please contact the factory.

The Power Soak PS-225 requires a low-foaming detergent that is safe for human hands. The detergent should have good grease cutting abilities but not have an excessively high or low pH level. A metal/aluminum-safe formula is recommended. Consult a chemical provider for a suitable deep cleaning chemical.



## Sanitizers

The method of sanitizing used in your Power Soak system is a "chemical sanitizing" method. There are a number of products on the market that work well. Your chemical sales representative should assist you in selecting the proper sanitizer for your application.

Check with your cleaning chemical provider to determine detergent concentration, sanitizer "parts per million" (ppm) and sanitizer submersion times to meet local health codes.

## Power Soak Service Assistance

If a chemical sales representative is having difficulty selecting a detergent or sanitizer, or if there are poor results with the chemicals that a representative has recommended, please contact the Power Soak factory at 800-444-9624.



# Power Soak<sup>®</sup>

## Operating Instructions

PS-225

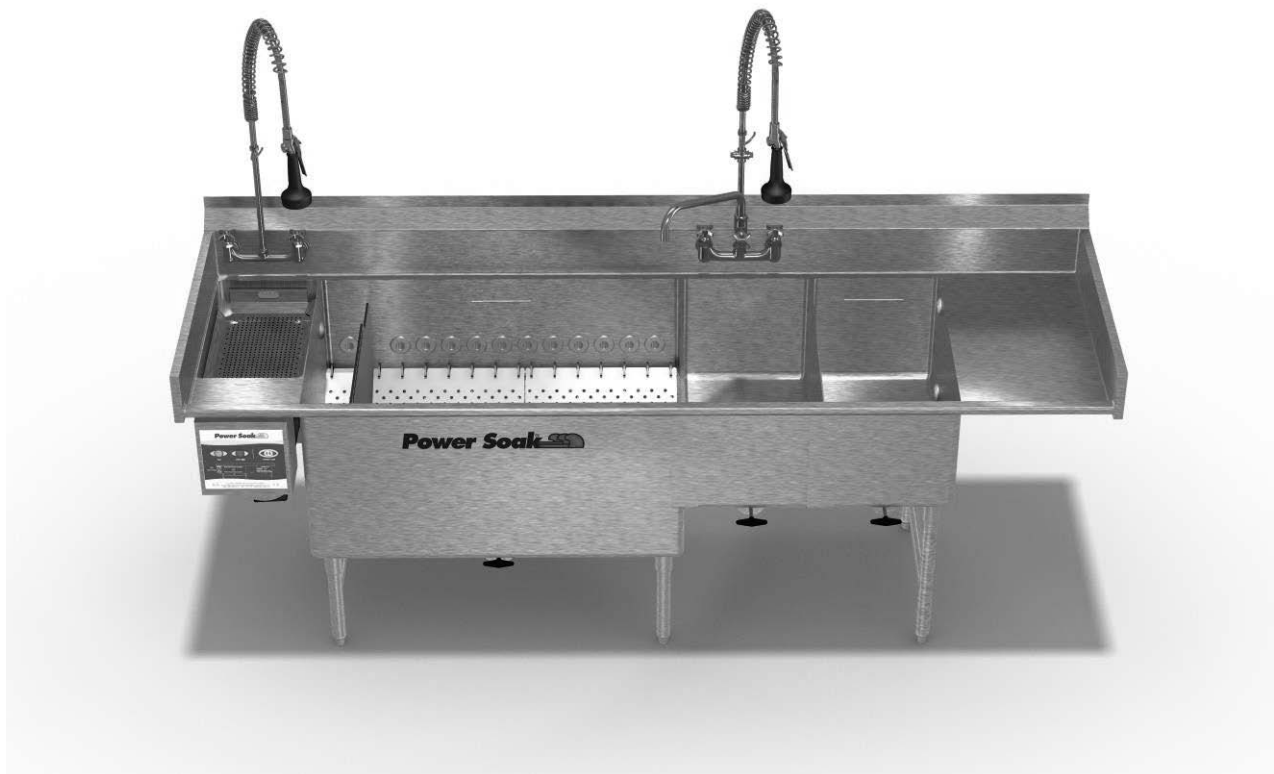

# Panel Front Controls and Features

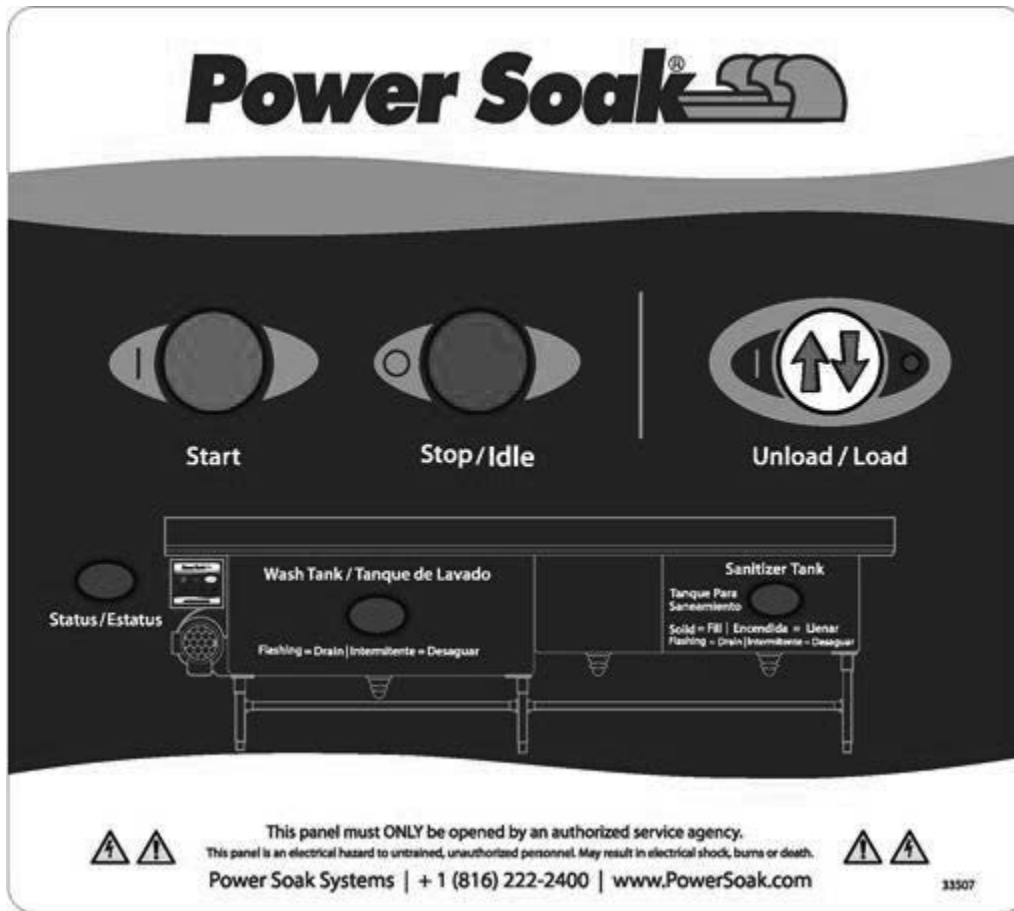

## START Button

The START button is green and labeled “Start”. It is used to start the wash action. If cycle does not start, refer to the trouble shooting section.



## STOP/IDLE Button

The STOP/IDLE mode button is red and labeled “Stop/Idle”. It is used to pause the wash action. The wash action will resume after a time, if the wash tank is not drained.



## UNLOAD/LOAD Button

The UNLOAD/LOAD button is white with green up and down arrows. It is used to indicate action to the controller when using the timed unload/load wash cycle functions.



## UNLOAD/LOAD Light

The UNLOAD/LOAD light is green and located next to the UNLOAD/LOAD button. It is used to indicate to the operator (along with the green indirect beacon) what action is needed in the timed unload/load wash cycle.



## STATUS Light

The STATUS light is green and labeled "Status/Estatus". It is used to indicate readiness of the wash tank and to indicate errors detected by the controller.



## WASH TANK Light

The WASH TANK light is blue and labeled "Wash Tank/Tanque de Lavado". It is used to indicate when the wash fluid needs to be changed.



## SANITIZER TANK Light

The SANITIZER TANK light is red and labeled "Sanitizer Tank/Tanque Para Saneamiento". It is used to indicate when the sanitizer fluid needs to be either filled or drained.



# Indirect Beacon System

The indirect beacon system shines ultra-bright lights on the floor to signal next actions to team members and managers. An optional wireless remote alert light kit is available to repeat these messages in another part of the kitchen.



Panel Bottom Lights



Wireless Remote Alert Lights

## Blue Beacon

The blue beacon is used alone and in combination with green and red to indicate action messages. Generally, these messages have to do with the wash tank.



## Green Beacon

The green beacon is used alone and in combination with red and blue to indicate action messages. Generally, these messages have to do with the timed unload/load cycle.



## Red Beacon

The red beacon is used alone and in combination with green and blue to indicate action messages. Generally, these messages have to do with the sanitizer tank.



# Preparing the System

## Filling the System

The STATUS light will flash indicating that the unit is powered and waiting to be started. At the beginning of each day or shift, fill the tanks with water that is metered to approximately the correct operating temperatures:

- Wash tank (115°F / 48°C)
- Rinse tank (75°F / 24°C)
- Sanitizer tank (75°F / 24°C)

All tanks should be filled to, but not above, the “waterline” marks. If your wash sink has dual waterlines, fill to the upper waterline when washing sheet pans held in racks and to the lower waterline for all other purposes.

## Wash Fluid

How you fill your wash tank (the tank with the water jets) may vary depending on how you dispense chemicals.

### Direct Dispensing

If your system directly meters chemical concentrate into the wash tank, fill the tank using the faucet with water that is approximately 115°F / 48°C. You can use the hot and cold taps on the faucet to adjust the water to the appropriate temperature. A good rule of thumb is that the water should be hot to the touch but not so hot that it is uncomfortable.

When the tank is full you may manually add chemical. If your system is equipped with the Power Soak Chemical Dispensing system. Chemical will be dispensed when the unit is started.

### Metered or Pre-Mixed Dispensing

If your system is filled via a metered chemical dispensing system the introduced water temperatures should be approximately 115°F / 48°C. Many times you can use the hot and cold taps on the faucet to adjust the water to the appropriate temperature. Some systems are supplied with a set of mixing valves to pre-mix the water to the correct temperature.

### Alerts

The PS-225 controller can help reduce labor in the fill process by signaling the team that a fill is nearly complete. This allows a team member to begin filling the tank, and return to other duties. When the tank is within a few minutes of completing its fill, the blue and green beacons will flash in an alternating pattern.



When the top liquid level sensor detects that the unit is full, the pattern will speed up to communicate urgency.

## Rinse Water

### Submersion Rinsing

If you rinse wares by submersing them in fresh water, fill the rinse tank (middle tank) with water that is approximately room temperature, 75°F/24°C. You can use the hot and cold taps on the faucet to adjust the water to the appropriate temperature. Drain and refill this tank as necessary to maintain clean water in the tank.

### Spray Rinsing

If you rinse wares with a fresh water spray, leave this tank empty, with the drain open.

Be sure to adjust knobs on the spray rinse and all water faucets so that the water temperature is below 120°F (49°C). Temperatures higher than what is recommended can cause scalding if contact is made with a person's skin.



## Sanitizer Water

### Direct Dispensing

If your system directly meters chemical concentrate into the sanitizer tank, fill the tank using the faucet with water that is approximately 75°F / 24°C. You can use the hot and cold taps on the faucet to adjust the water to the appropriate temperature. A good rule of thumb is that the water should be room temperature.

When the tank is full you may manually add chemical. If your system is equipped with the Power Soak Chemical Dispensing system, chemical will be dispensed when the water is detected by the upper water level sensor.

### Metered or Pre-Mixed Dispensing

If your system is filled via a metered chemical dispensing system the introduced water temperatures should be approximately 75°F / 24°C. Many times you can use the hot and cold taps on the faucet to adjust the water to the appropriate temperature. Some systems are supplied with a set of mixing valves to pre-mix the water to the correct temperature.

### Alerts

The PS-225 controller can help reduce labor in the fill process by signaling the team that a fill is nearly complete. This allows a team member to begin filling the tank, and return to other duties. When the tank is within a few minutes of completing its fill, the red and green beacons will flash in an alternating pattern.



When the top liquid level sensor detects that the tank is full, the pattern will speed up to communicate urgency.

## Adding Detergents & Sanitizers

After the sinks have been filled with water, add the proper amount of detergent and sanitizer. The detergent goes into the wash tank (the tank with the water jets) and the sanitizer goes into the sanitizer tank (the tank furthest from the wash tank).

Be sure to add the proper amount of chemicals to each tank. The amount to be used should be provided by your chemical supplier. Do not add the detergent or sanitizer to the tank prior to or during filling.

Most detergents and sanitizers lose effectiveness as time goes on. Some local health departments have requirements limiting the amount of time water can be used for cleaning before the water should be changed. Most chemical companies recommend changing wash water after a certain time frame. Those times vary, but are generally around four hours. Check with your chemical provider.

Check with your chemical provider on how often to check and or replace your sanitizing fluid.

### Your Chemical Company Should Be Aware of the Following:

The detergent must be low foaming, metal/aluminum-safe and not excessively caustic. Most standard sanitizers are acceptable.

# Operating the Power Soak

## Starting and Stopping the Wash Action

To start the wash action, press the green “START” button. A strong “rolling” action should be present. When the wash cycle is started the green STATUS light will change from flashing to solid. When the STATUS light is solid, the wash fluid timer is timing down to the next wash fluid change.

To pause the wash action, press the red “STOP/IDLE” button. This puts the system into an idle mode. The wash action cannot be completely stopped without draining the wash tank. When the system is in idle mode, the small indicator light beside the Unload/Load button will be flashing. It will flash faster and faster until the unit auto restarts.

Wares tumbling in the Power Soak wash sink may splash fluid from the sink creating a wet floor in front of the Power Soak wash sink. Be aware that a wet floor may cause a person to slip and fall creating a serious injury or death.



## Introducing Pots and Pans to the Power Soak

Dirty pots and pans should be brought to the Power Soak in a timely manner. Do not allow items to sit and air dry. The quicker that items are brought to the Power Soak and put in the wash tank, the easier they are to clean!

## Properly Scrapping Pots and Pans

Excess soils should be removed from the pots and pans prior to dropping them in the wash tank.

Deposit the excess soils into a garbage can.

Some systems may have an optional pre-scrapping area with a pre-rinse spray. If so, soils may be deposited into the scrapper sink.

Empty the scrap collection tray regularly.

## Loading and Using the Wash Tank

The Power Soak is a “random loading” system. This means that Power Soak items are not racked for washing. Instead, they are randomly loaded one at a time.

As items are brought to the system and scrapped, they should be immediately dropped into the wash tank.



Power Soak is a “continuous motion” system. This means that the system does not operate on a set cycle time like cabinet-type washing systems. Instead, during normal operating hours where washing is required, the system is (normally) left running. The Power Soak is energy efficient, and it does not cause excessive wear to leave it running continuously.

Typically, it takes between three to fifteen minutes to wash items. Some heavily soiled or burnt-on items may take longer to clean.

Do not attempt to occupy any of the sinks on the Power Soak machine. Be cautious not to fall into any of the sinks on the Power Soak machine. The fluid depth is sufficient for a person’s head to be submerged and cause a drowning death.



### Overloading

If there is no movement of items in the wash tank, or if items are stationary above the waterline, the system has been overloaded and some items must be removed.

It is very important not to overload the wash tank as it reduces the effectiveness of the wash action.

### Nesting

Some pots and pans stack for storage. This is referred to as “nesting” when it occurs during a Power Soak wash cycle. Make sure that nested items are separated and loaded one at a time. Nested items in the wash tank will not be properly washed.

## Unload/Load

The Power Soak sink should not be monitored continuously. There are a couple of ways to manage the ware washing task using a Power Soak.

### Continuous Throughput

One way to manage labor with the Power Soak is through the process of completing a wash cycle when an item is dropped off. When a ware is dropped off the team member will:

1. Scrap the soiled ware and drop it into the wash tank.
2. Remove a clean ware from the wash tank, rinse it and drop it into the sanitizer tank.
3. Remove a sanitized ware from the sanitizer tank and place it on the clean drain board to air dry.
4. Remove a dry ware from the clean drain board and place it in the proper storage location.

By following these steps a complete wash cycle is completed every time a ware is dropped off. It should take only a minute or two to complete the cycle and the Power Soak is not continuously monitored.

### Timed Unload/Load

The Power Soak PS-225 is equipped with the ability to batch the wash cycle without having to be continuously monitored. If enabled, this feature will time wash and Unload/Load cycles. The work flow is like this:

1. Drop off soiled wares on a soiled landing area like the soiled drain board.
2. Scrap and fill the wash tank with a full load of wares. The controller will time a wash cycle.
3. At the completion of the timed wash cycle the green beacon will flash.



The flashing beacon indicates that the timed wash cycle has expired and an unload/load cycle should be performed.

4. When a team member arrives to perform the unload/load cycle, they should first press the  button on the panel front. The green flashing beacon will turn solid to acknowledge.



Dry sanitized wares should be moved to their designated storage location.

5. All wares should be removed from the sanitizer tank and arranged for air drying on the clean drain board.
6. All wares should be removed from the wash tank, rinsed and placed in the sanitizer tank. When necessary some finishing (light hand scrubbing) may be necessary.
7. A full load of soiled wares should be scrapped and placed in the wash tank.
8. When these tasks are complete, press the  button on the panel front. The green flashing beacon will turn off to acknowledge the completion of the unload/load cycle. The wash timer will be started and the cycle will repeat. The team member may return to other duties.

Between cycles, soiled wares should be dropped off on the soiled drain board or other soiled ware landing area.

## Loading and Washing Utensils

Each PS-225 Power Soak system comes with a utensil area that is a 6" divided area in the wash tank. All utensils and other small wares should be loaded into and washed inside this area.

Do not place knives or other sharp objects in the Power Soak. Allowing knives or other sharp objects to tumble freely in the Power Soak tank may cause bodily injury.

Knives and other sharp objects must be washed by hand with the pump motor turned OFF. Wash, rinse and sanitize the knife or sharp object, without letting go of the item and immediately place the item into proper storage.



A fully loaded utensil basket can be very heavy. Unload the basket prior to lifting the basket out of the sink. Do not attempt to lift a fully loaded utensil basket. Attempting to lift a fully loaded utensil basket can cause a muscle strain.



## Rinsing Pots and Pans

Clean items that have been removed from the wash tank or utensil area should be thoroughly rinsed. This is achieved by spraying them off or dipping them in the (center) rinse tank.

It is important that any remaining detergent residue is removed from the items prior to sanitizing.

If items are rinsed by the "dipping" method, it is important to keep the water "fresh" by frequently draining and filling the rinse tank.

## Sanitizing Pots & Pans

After items have been properly rinsed they must be sanitized in the sanitizing tank.

It is necessary for each item to remain submersed in a correctly titrated sanitizing solution for a specific amount of time. The amount of time varies according to the type of sanitizer being used and local health codes.

Be sure to follow your chemical sales representative's instructions to ensure that all items are properly sanitized.

## Drying of Pots & Pans

After items have been sanitized, they should be thoroughly dried on a clean drain board or on adjacent drying shelves.

Be sure to adhere to all local health codes and recommendations for proper drying and stacking of items.

## Deep Cleaning and "Night Washing"

Use your Power Soak as a "total cleaning system"! Remember, any item in your operation that can be submersed for cleaning and is not fragile or sharp can be washed without labor in your Power Soak!

Extremely soiled items and pieces of cooking equipment that require regular, intensive cleaning can be washed in the Power Soak system overnight.

Start with a fresh washing solution. Load the items to be deep cleaned into the Power Soak's wash tank. Press the green START button to start the wash action. Leave it to run overnight. A different chemical may be beneficial for this cycle, see your chemical supplier.

The overnight cleaning will automatically turn the wash action on and off throughout the night. No attention needs to be paid to warning beacons that might affect the operation during normal business operations.

Here are some examples of items that are typically deep-cleaned overnight in the "Night Wash" cycle:

- Hood Filters
- Roasting Pans
- Stove Tops
- Frying Equipment
- Stock pots
- Carbonized items
- Soiled storage racks

Many other items in your operation may qualify. Be creative and set up a regular "Night Wash" program for improved sanitation.

Items that have been cleaned overnight can be removed, rinsed, sanitized (if necessary) and put away or back in place.

## Changing the Wash Solution

The wash solution will need to be drained and refilled every four hours. The controller will keep track of this time. 15 minutes before the wash tank timer expires, the blue beacon will begin flashing.



The beacon will flash faster and faster until the timer expires. When the timer expires, the wash action will stop and the blue beacon will become solid.

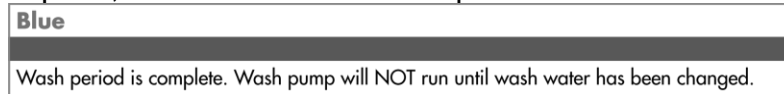

This indicates that it is time for the wash fluid to be changed. The wash action can be restarted for one minute using the  button to aid in unloading the wash tank before draining. (This can be repeated five times)

## Changing the Sanitizer Solution

In most cases, the sanitizer solution will need to be drained and refilled every two hours. In some situations a chemical provider and local codes allow a longer change interval. When the sanitizer tank is filled a timer is started. 15 Minutes before the sanitizer tank timer expires, the red beacon will begin flashing.

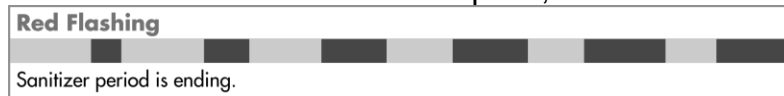

The beacon will flash faster and faster until the timer expires. When the timer expires, red beacon will become solid.



If the tank does not detect a solution change after a time, the wash action will stop and the red and blue beacons will flash in an alternating pattern.

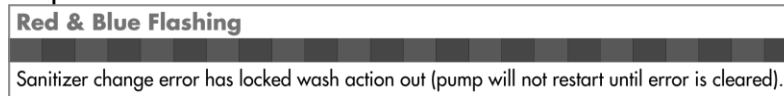

Once this has happened, the only way to restart the wash action is to drain and refill the sanitizer tank.

## Checking the Sanitizer Solution

The sanitizer tank can be set up to prompt concentration checks. If the controller determines that it is time for a concentration check, the red beacon will flash a three pulse pattern.

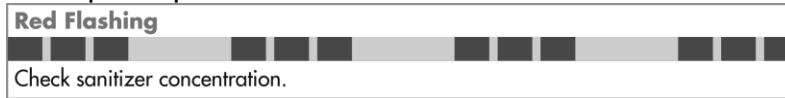

The team member that will be checking the concentration should press the red STOP/IDLE button. The beacon should change to a steady flashing pattern.



The concentration should be checked. The system will flash steady for a time to discourage canceling the alert without performing the concentration check. Once this time has expired the red beacon will become solid.



If the concentration is incorrect, the tank should be drained and refilled. If the concentration is correct, the red STOP/IDLE button can be pushed to cancel the alert.

## Wash, Rinse and Sanitizer Clean-Up

Between each water change and at the end of each night, all tanks and drain boards should be thoroughly cleaned with hot, soapy water.

It is also recommended to wipe down all the tanks and drain boards with a sanitizing agent. Ask your chemical provider to recommend a sanitizer for this application.

# Power Soak<sup>®</sup>

## Preventative Maintenance

PS-225

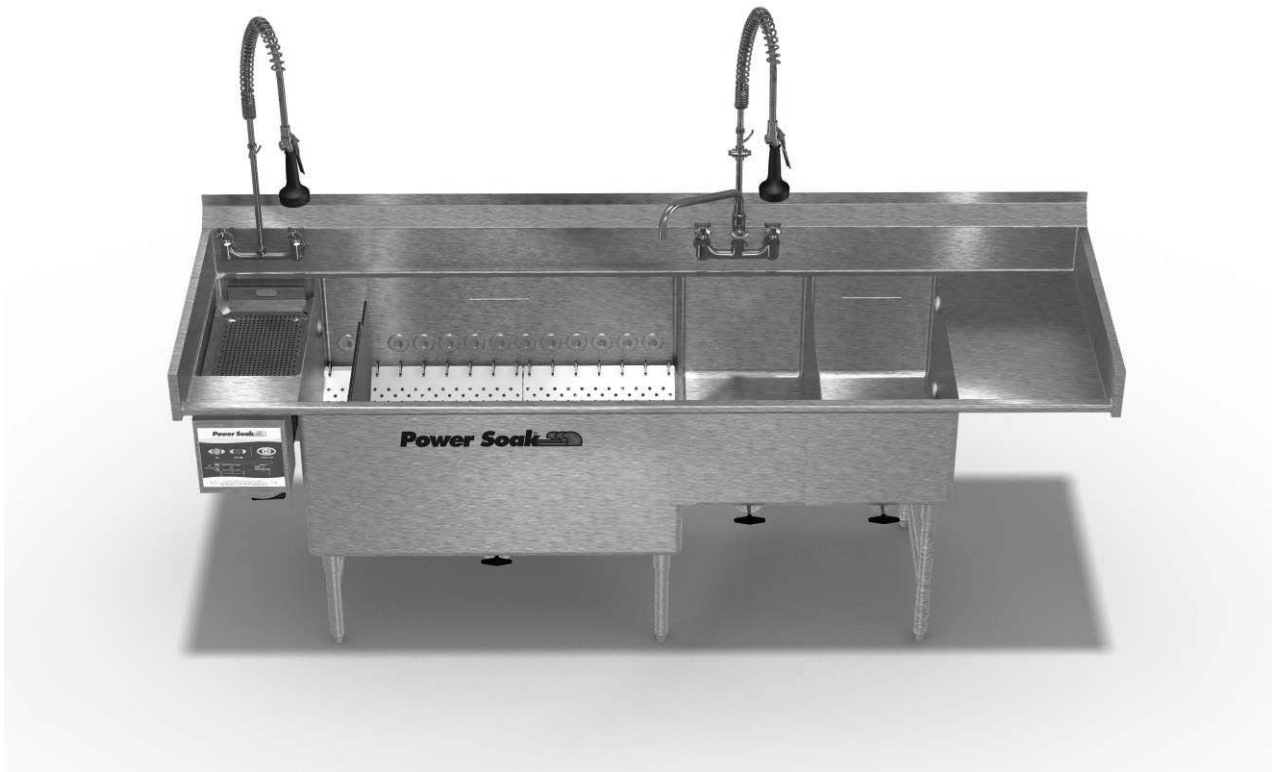

Your system requires minimal, routine preventative maintenance. As such, the following should be done on a routine basis to ensure that your system remains reliable:

## Daily

Clean the liquid level sensors. These sensors are located on the side walls of the wash and sanitizer tanks. They are the white plastic discs with metal centers. Clean the sensor faces thoroughly. If cleaned regularly, a washcloth and soapy water are all that is required.

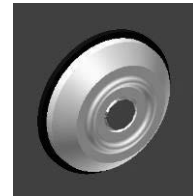

If the liquid level sensors are not cleaned regularly, the machine may fail to operate; or it may be possible to run it without water, which will cause serious damage to the PS-225. Running the machine without water in the wash tank will cause damage that is not covered by warranty.



## Monthly

**IMPORTANT:** Turn off the power to the PS-225 at the main breaker prior to performing the following task!



Clean the pump motor fan shroud with a damp, soapy cloth. The motor shroud is the "vented" cover located at the end of the motor (closest to the control panel). This will prevent grease and dust from accumulating in the cover's openings, which can obstruct the airflow that cools the motor.



## As needed

De-lime the wash tank. Simply add a recommended titration of de-liming agent to a tank of warm, fresh water and run the system overnight. Ask your chemical sales representative to recommend a specific de-liming agent.

There are no other preventive maintenance procedures that you will need to perform on your Power Soak system. You need not be concerned about greasing the motor bearings, as they are permanently sealed. If you have any questions regarding the preventative maintenance procedures, please contact the factory at 800-444-9624.



This Page Left Intentionally Blank

# Power Soak<sup>®</sup>

## Troubleshooting

PS-225

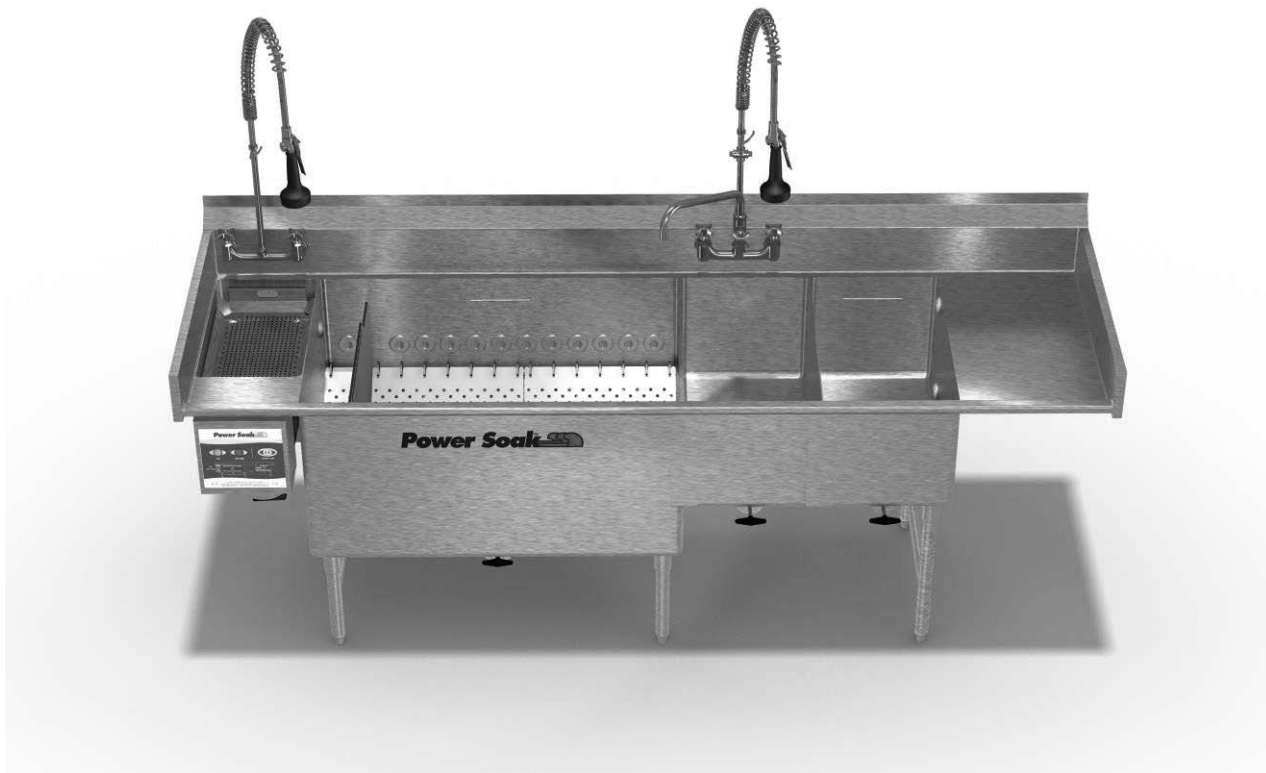

## Facility Owner/Manager Section

The only troubleshooting procedure that the facility owner or manager can perform is listed immediately below. All other procedures must be performed by an authorized service agency. To obtain the name of a recommended service agent in your area, please call the Power Soak Service Department at 800-444-9624.

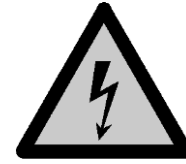

If the wash action will not start or the unit will not maintain temperature:

Check to make sure the main electrical power breaker for the Power Soak system is in the "ON" position.

Check to make sure the wash tank is filled to the waterline.

Check to make sure that the liquid level sensors are clean and free of any debris or grease. The liquid level sensors are located on the side walls of the wash and sanitizer tanks (the white plastic disc with a metal center).

Check to make sure the temperature of the water in the wash tank is below 120F.

If the above trouble shooting procedures do not correct the problem, you must contact Power Soak Systems, Inc. at 800-444-9624 or an authorized service agency. Have the serial number of your machine ready when you call.

## Authorized Service Agency Section

There are hazards to untrained or unauthorized personnel. The following procedures are provided for use only by an authorized service agency. No facility owner, manager, employee or other unauthorized person should attempt to perform any of these procedures. To obtain the name of a recommended service agent in your area, please call the Power Soak Service Department at 800-444-9624.



When performing troubleshooting procedures, the authorized service agency will need to open the Power Soak machine's main electrical enclosure cover. The cover to the enclosure must be properly closed before reconnecting the power to the machine.

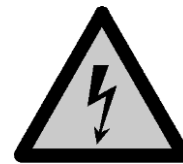

### Explanation of LED Sequence

To verify the proper operation of the Power Soak system, the operating logic of the controls should be verified. To verify the logic, the control box will need to be opened.

The Universal Programming Module (UPM) is mounted to the inside of the control enclosure cover.

The UPM has four LEDs mounted on its top edge. The meaning of each LED is as follows, starting from the right-most LED:

1. Power On
2. Error Code
3. W-L is wash tank low level
4. W-H is wash tank high level
5. S-L is sanitizer tank low level
6. S-H is sanitizer tank high level

## Wash Pump/Heater Will not Operate

Refer to the previous checklist under the “Facility Owner / Manager Section” before proceeding to the following checklist items:



Verify that LED #1 (Power On) is illuminated. If LED #1 is not illuminated, check:

Main power connection and wiring

Fuse inside the control enclosure

Bi-metallic disc switch for water temperature (switch must be closed if water temperature is below 120°F)

Bi-metallic disc switch for motor temperature (switch must be closed if motor temperature is below 150°F)

Check to see that the Liquid Level LEDs #3 and #4 are illuminated when the wash tank is filled to the waterline.

To test the Liquid Levels in the sanitizer tank:

Start the machine before filling the sanitizer tank, the red light will come on steady and show on the floor. When the sanitizer tank is filled and reaches the high level the red light goes out.

If either one or both of the lights are not illuminated or the red beacon acts different than described above:

Clean the liquid level sensors as described in the “Preventive Maintenance” section of this manual.

Be sure that all connections to and from the Liquid Level sensors are secure and that there is no physical damage to the wiring.

If damage to connectors and/or wiring is found, contact Power Soak Systems, Inc. at 800-444-9624.

If the above troubleshooting guidelines do not correct the problem, it will be necessary to contact Power Soak Systems, Inc. at 800-444-9624.

Prior to calling, please note the “Error Code” (if any) that can be identified by observing LED #2 on the UPM and the “Status” green LED on the front of the control panel. If there is a control logic error, LED #2 will flash with a “blinking” pattern. The definitions for the patterns are as follows:

“–” symbol represents a “long” flash

“.” symbol represents a “short” flash

3 long & 1 short – – – . = Liquid Level Error

3 long & 2 short – – – . . = Temperature Sensor Error

3 long & 3 short – – – . . . = Over-Current Error

3 long & 4 short – – – . . . . = Over Temperature Error

3 long & 5 short – – – . . . . . = Current Sensor Error

3 long & 6 short – – – . . . . . . = Membrane Error

Please have this “Error Code” information available prior to calling Power Soak Systems.

Please also have the systems serial number. This number is 5-6 digits long and located on the lower corner of the wash tank closest to the controller.

Note: If the System is flashing an error code, try having the service person cycle the breaker for the Power Soak as sometimes unstable power can cause a false error.

This Page Left Intentionally Blank

# Power Soak®

## Installation

PS-225

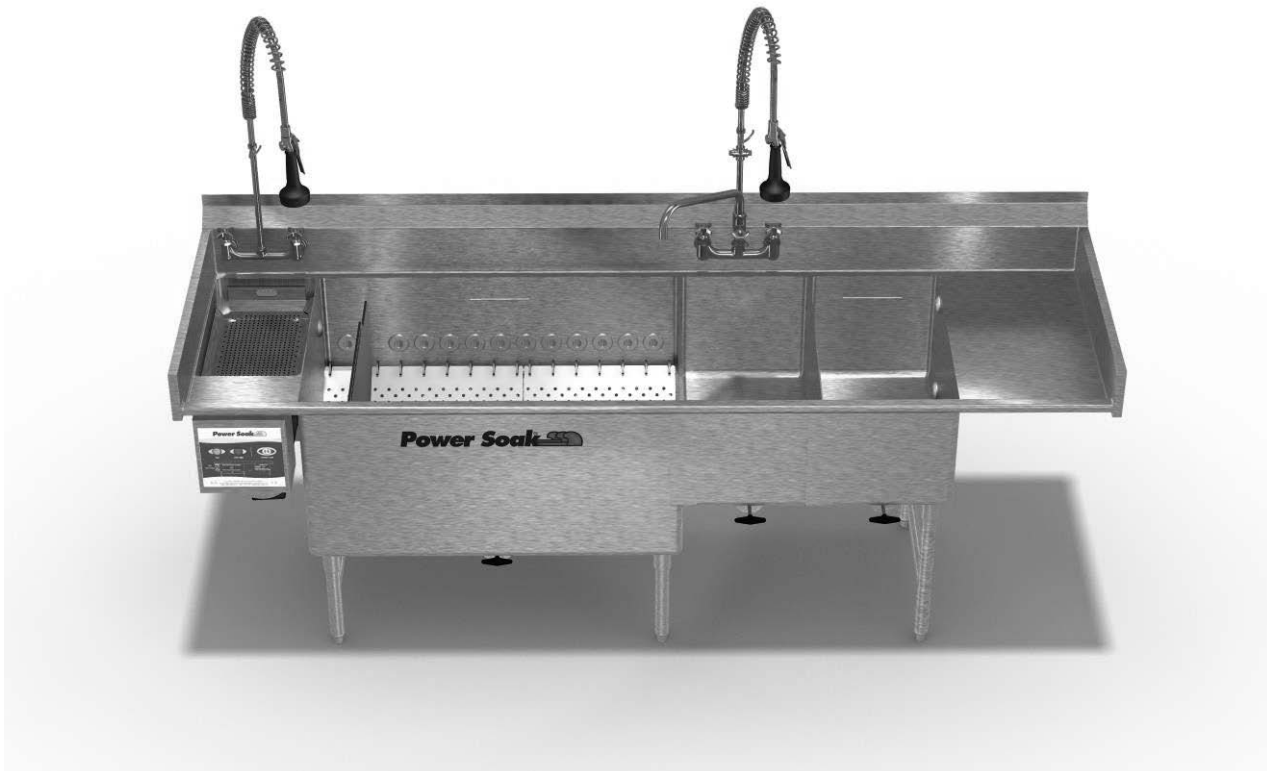



The installation and initial operational check of the PS-225 must be performed only by licensed and certified plumbers and electricians.



Be sure to follow all applicable national and local electrical codes when installing the electrical supply and/or a new breaker. DO NOT connect the machine using a power cord and plug or an extension cord of any kind.



Please refer to the detailed installation instructions that were sent with your Power Soak system.

## Electrical Requirements

The electrical requirements of your new system are on the serial number plate located on the front corner of the wash tank, adjacent to the control panel enclosure and inside the enclosure itself.

All Power Soak systems have a single point electrical connection, and a dedicated circuit is required. A  $\frac{3}{4}$ " seal tight conduct knock out is provided on the rear of the control panel.

The system is completely pre-wired and tested at the factory, and a hard-wired connection from an appropriate power source junction box is all that is required.

The installer is to provide a disconnect that should be incorporated in the fixed wiring. Note: In areas where the walls are washed this should be a waterproof style disconnect.

Properly sized watertight conduit, fittings and parts are required, as well as the appropriate gauge wire.

If your system is a "left-to-right" unit, you should locate the power source junction box at the left end of the system. (The opposite would be true for a "right-to-left" system.)

Ideally, the junction box should be located on the wall directly behind the pump motor and control panel.

If the system requires 3 phase power, the motor rotation can be tested by holding down the start button for 10 seconds, with no water is in the system. This will bump the motor. Verify the motor rotation matches the arrow on the pump housing.

An equipotential bonding terminal is provided on the side of the wash tank and identified with the symbol shown at the right of this statement. This terminal is used to make a connection for properly grounding the machine. This connection must be completed by a qualified electrical technician.



Symbol for  
Bonding  
Terminal

A wiring diagram is located in the system's control panel enclosure. Specific part numbers and part information can be obtained from the factory by calling 800-444-9624.

## Plumbing Requirements

Your unit requires the following plumbing connections:

3/4" (19mm) or 1/2" (12 mm) hot and cold water supply lines.

One waste water connection (minimum 1-1/2" 38mm).

A 3" (75mm) connection is recommended for an in-floor main line.

The Rear Exit Drains supplied have a female 1-1/2" connection.

DO NOT USE HOSES to make the pressure connections to the faucets. Maximum water inlet pressure is not to exceed 125 psi (8.6 Bar), minimum water pressure to be not less than 20 psi (1.2 Bar).

## Decommissioning

When it is time to decommission the PS-225 the components of the machine are to be recycled. The electrical control panel and motor have materials that must not be discarded into common trash disposal. Dispose of the control panel contents and the motor through a proper waste electrical and electronic source or return the contents and the motor to the source where the PS-225 was purchased.

The metal in the sinks and control panel enclosure has a value in the recycled metals market. The owner of the PS-225 can recover this value by directly contacting a metal recycling facility and making arrangements to recycle the metal.

If any or all of the PS-225 is returned to the source where it was purchased, there will be no obligation for the Power Soak representative to make any compensation for the returned materials.



The Power Soak design and concept is fully patented.

**Unified Brands**

1055 Mendell Davis Drive

Byram, MS 39272

888.994.7636

[www.unifiedbrands.net](http://www.unifiedbrands.net)

Part#: 33755

Rev: K

Rev Date: 11/6/2015