

# OPERATING INSTRUCTIONS

## Slim Line Bagel And Specialty Toaster

Model No. 196 and 296 Series Toasters

*Excalibur*<sup>®</sup>

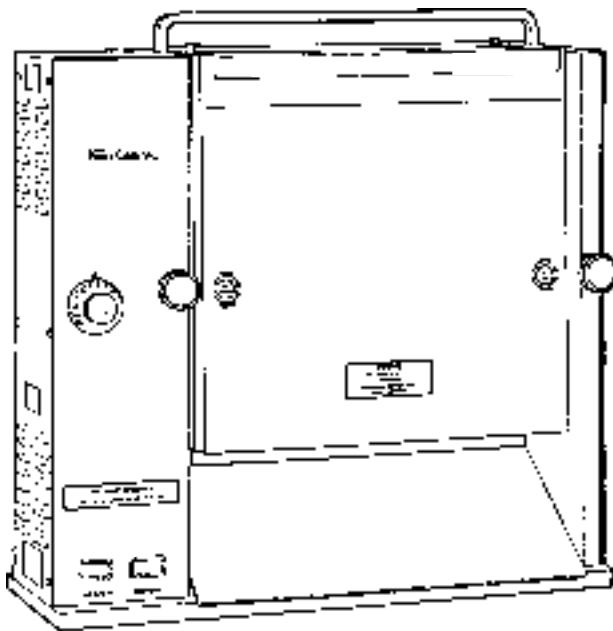

### PRODUCT SPECIFICATIONS

**Electrical:**

Model No.	Volts	Hz	Watts	KW	Amps
196/296	110/120	60	1500	1.5	12.5

### TABLE OF CONTENTS

PAGE

Installation .....	2
Operating .....	2-3
Adjustments and Cleaning.....	3
Troubleshooting .....	4
Parts List.....	4-7
Wiring Diagram .....	7

### LIMITED WARRANTY

This product is warranted to be free from defects in material and/or workmanship for a period of two (2) years from date of original installation, not to exceed 30 months from date of shipment from our factory. Any part or component which proves to be faulty in material and/or workmanship within the warranty period will be replaced or repaired (at the option of Prince Castle, Inc.) without cost to the customer for parts or labor.

This warranty is subject to the following exceptions/conditions:

- Service must be performed by an authorized Prince Castle Service Center.
- Any use of non-genuine Prince Castle spare parts voids this warranty.
- This equipment is portable; charges for on location service (e. g., trip charges, mileage) are not include in the provisions of this warranty.
- All labor shall be performed during regular working hours. Overtime premium will not be covered.
- Damage caused by carelessness, neglect, and/or abuse (e.g., using wrong current, dropping, tampering with or altering electrical components, or improper cleaning) is not covered by the terms of this warranty. Equipment damaged in shipment, by fire, flood or an act of God is not covered.
- Normal adjustments as outlined in this manual are not covered under warranty.

## INSTALLATION

- After removing the toaster from the carton, promptly inspect the unit for signs of damage. If there is damage to the unit:
  - Notify carrier within 24 hours of receipt.
  - Save carton and packing material for inspection purposes.
  - Contact the Prince Castle Customer Sales Department at 1-800-722-7853 to arrange for a replacement to be sent.
- Verify that all parts were received.
  - The Line Cord is separate from the toaster and can be found folded at the bottom of the box.
  - The Teflon sheets are located in a 14" box located in the bottom of the toaster box.
  - The Crumb tray is attached by nylon tape to the front of the conveyor. Remove and install it to the bar located below the conveyor assy.
- Lift conveyor off conveyor guide rails. Remove packing material (nylon tape, foam block and black rubber packaging spacers) from conveyor and conveyor guides. Set conveyor aside. (Figure 1)

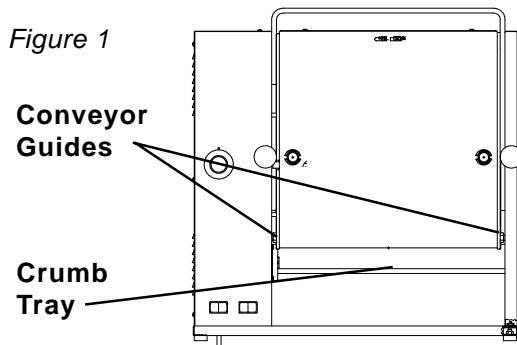

- Plug unit into a 110-120 volt grounded receptacle.

## OPERATION

- Place the teflon release sheet over the top of the platen housing, making sure there are three inches of overhang. (Figure 2)

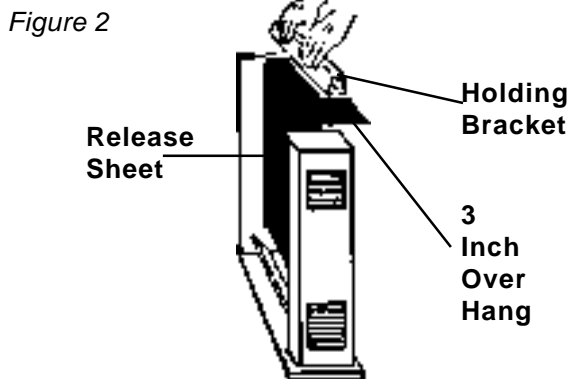

- Firmly place the holding bracket on top of the platen housing to securely hold the release sheet in place. (Figure 2)

- Place the conveyor housing into the conveyor guide and lower making sure that all four conveyor slides are inside the conveyor guide. (Figure 3)

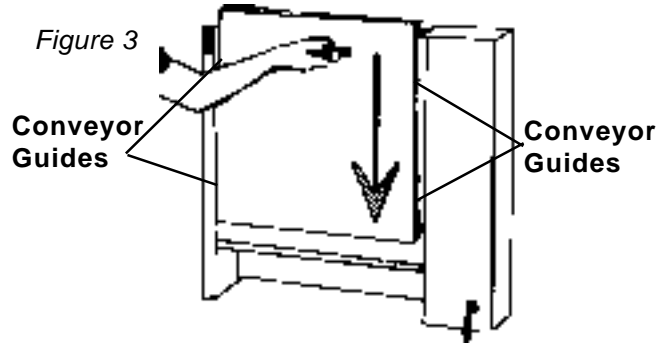

- Turn the heater switch to the "on" position (the orange indicator light will come on). Allow 30 minutes for platen to reach operating temperature. (Figure 4)
- Turn the motor switch to the "on" position (the orange indicator light will come on). (Figure 4)

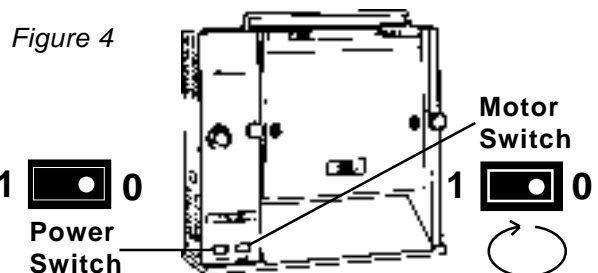

**Note:** Turn the Motor switch off when not in use to conserve energy

- Check the conveyor chain to ensure that it is turning freely.
- Place a sample run of the product being toasted into the top of the conveyor housing, with the cut side facing the platen. (Figure 5)

Figure 5

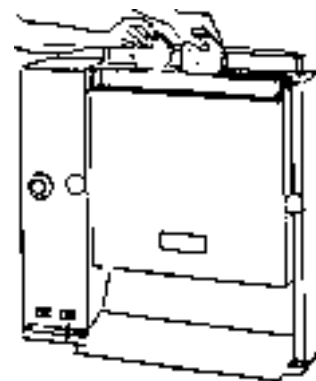

- The toasted product should appear on the crumb tray in 30-35 seconds on model 196 and in 15-18 seconds on model 296.

## ADJUSTMENTS

### Bun Compression

The toaster platen can be adjusted to provide the necessary compression needed on various products. Turn the two platen adjustment knobs clockwise to compensate for use on thicker bread products, counter clockwise for thinner products. (Figure 6)

Figure 6

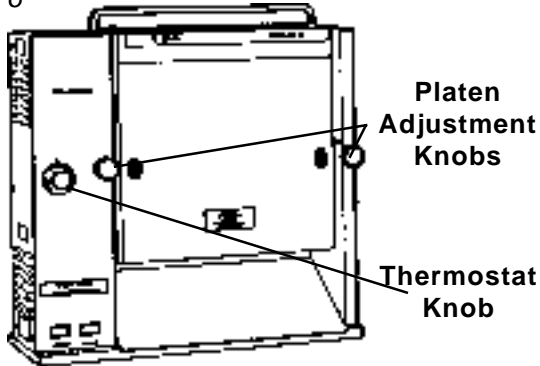

### Platen Temperature:

The temperature of the platen can be adjusted to compensate for darker or lighter toasting requirements. Turn the thermostat adjustment knob clockwise for darker toasting, counter clockwise for lighter. Allow 10 minutes for toaster to stabilize whenever the thermostat is adjusted. (Figure 6)

### Factory Setting:

The 196 Series Toaster thermostat is set at # 7

The 296 Series Toaster thermostat is set at # 9

### Conveyor and Motor Gears:

The top of the conveyor housing should be even with the tops of the end housings and there should be a 1/64" clearance between the conveyor and motor gear when aligned properly. To adjust the conveyor housing, use the 3/32 Allen wrench on the adjustment screws located on the bottom on both sides of the conveyor guide, turn clockwise to raise the conveyor housing, counter clockwise to lower. (Figures 7 & 8)

Figure 7

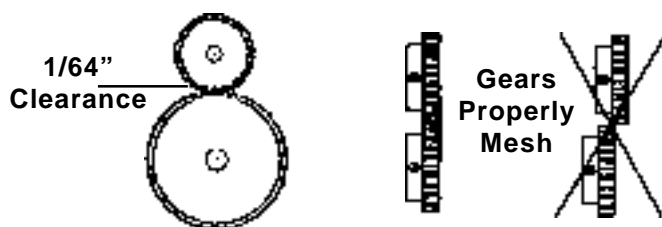
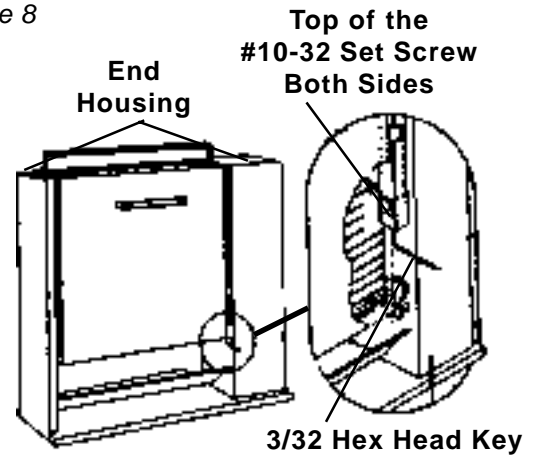

Figure 8



## CLEANING

1. Turn off both the heater and motor switches and unplug the toaster.
2. Allow platen to cool before proceeding.
3. Remove the conveyor assembly.
4. Immerse the conveyor housing into sink with hot water and detergent. A soft bristle brush can be used on hard to clean spots. Rinse thoroughly and allow to air dry.
5. Remove the teflon sheet and lay it on a flat surface. Thoroughly clean both sides with a damp cloth making sure all carbon build up is removed. Allow to air dry.
6. Use a damp cloth to remove any carbon build up on the platen surface.

**Note:** Rotate two sheets daily for longer life. Sheets last 4-6 months based on care and volume of product toasted.

**Note:** Do not use sharp objects, scotch brite pads, scouring pads, or abrasive cleaners on the platen, or teflon release sheets as it will cause irreparable damage.

# TROUBLE SHOOTING

Problem	Cause	Solution
1. Unit will not heat up. Power Rocker Switch Light Off.	A. No Power. B. Inoperable Power Cord. C. Loose Connection on Switch. D. Inoperable Power Switch.	Ensure Power Cord is Connected to Proper Receptacle. And the Power Inlet. Replace Power Cord. Tighten Power Switch Connections. Replace Power Switch.
2. Unit will not heat up, Power Rocker Switch Light On.	A. Inoperable Thermostat. B. Inoperable Platen.	Replace Thermostat. Replace Platen.
3. Unit Heats up but the conveyor does not run.	A. Loose Motor Switch Connection. B. Inoperable Motor. C. Stripped Drive Gear. D. Loose Chain Sprockets. E. Gears Not Meshing. F. Inoperable Motor Switch.	Tighten Motor Switch Connection. Replace Motor. Replace Drive Gear. Adjust and Tighten Sprockets. Adjust Conveyor Set Screws (See Conveyor Adjustments Page 3). Replace Switch.
4. Unit over and under heats ( does not respond to thermostat adjustments).	A. Inoperable Thermostat.	Replace Thermostat.
5. Buns under or over done.	A. Check Platen Adjustment. B. Check Platen Temperature.	Adjust Platen for Proper Compression (See Platen Adjustments Page 3). Adjust Thermostat for Proper Temperature (See Thermostat Adjustment Page 3).

## FRONT VIEW

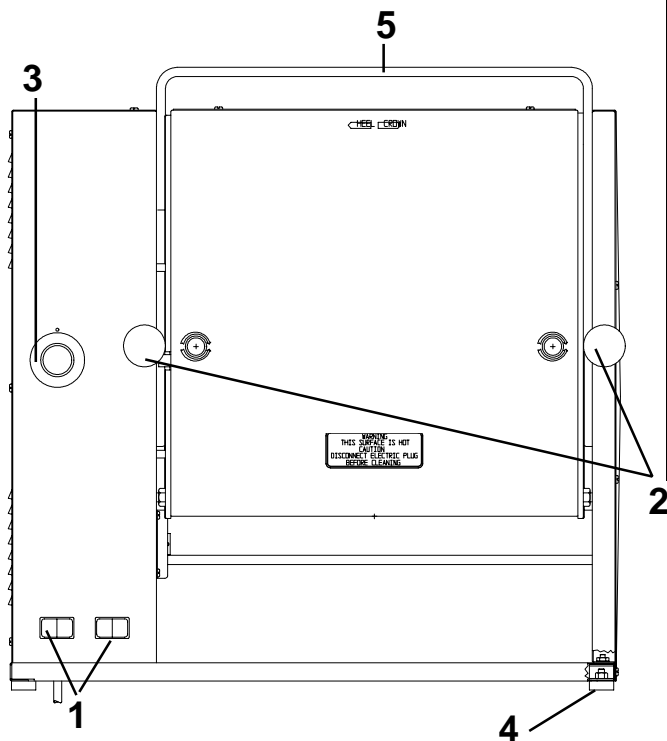

## PARTS LIST

Item	Part Number	Description
1	78-184S	Power and Motor Lighted Rocker Switch
2	197-185S	Platen Adjustment Knob (Pkg of 2)
3	70-012	Thermostat Knob
4	197-232	Foot
5	197-124	Conveyor Guide
*	197-402	Release Sheet Conversion Kit (196, 296 and 196-SP)
*	196-13	Release Sheet Conversion Kit (196-JACK)
*	197-260	Release Sheets (Pkg of 2) (3 MI) (196, 296 and 196-SP)
*	196-12	Release Sheets (Pkg of 2) (5 MI) (196-JACK)
*	NOT SHOWN	

# CONVEYOR ASSEMBLY

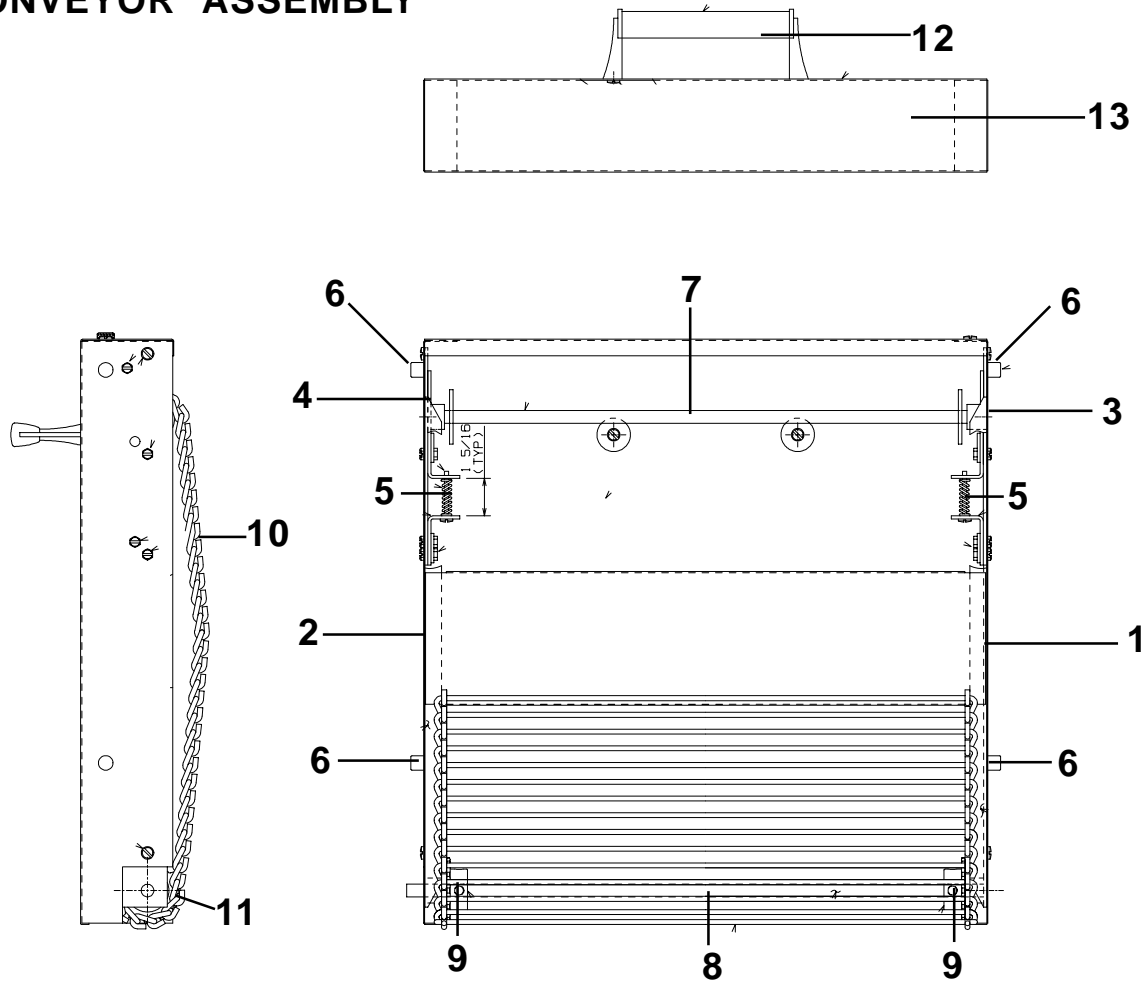

## PARTS LIST

Item	Part Number	Description
1	197-461	Right Side Shaft Carrier Assy.
2	197-463	Left Side Shaft Carrier Assy.
3	197-459	Right Side Shaft Carrier Adjustment Assy.
4	197-457	Left Side Shaft Carrier Adjustment Assy.
5	81-015	Compression Spring
6	197-467	Conveyor Slide
7	197-280	Shaft Assy.
8	197-465	Driven Shaft
9	197-302	Sprocket Kit (Pkg of 2)
10	89-684	Complete Chain Assy.
11	89-590	Single Conveyor Chain Link
12	346-5	Black Handle With Screw
13	197-322S	Complete Conveyor Assy.

## REAR VIEW

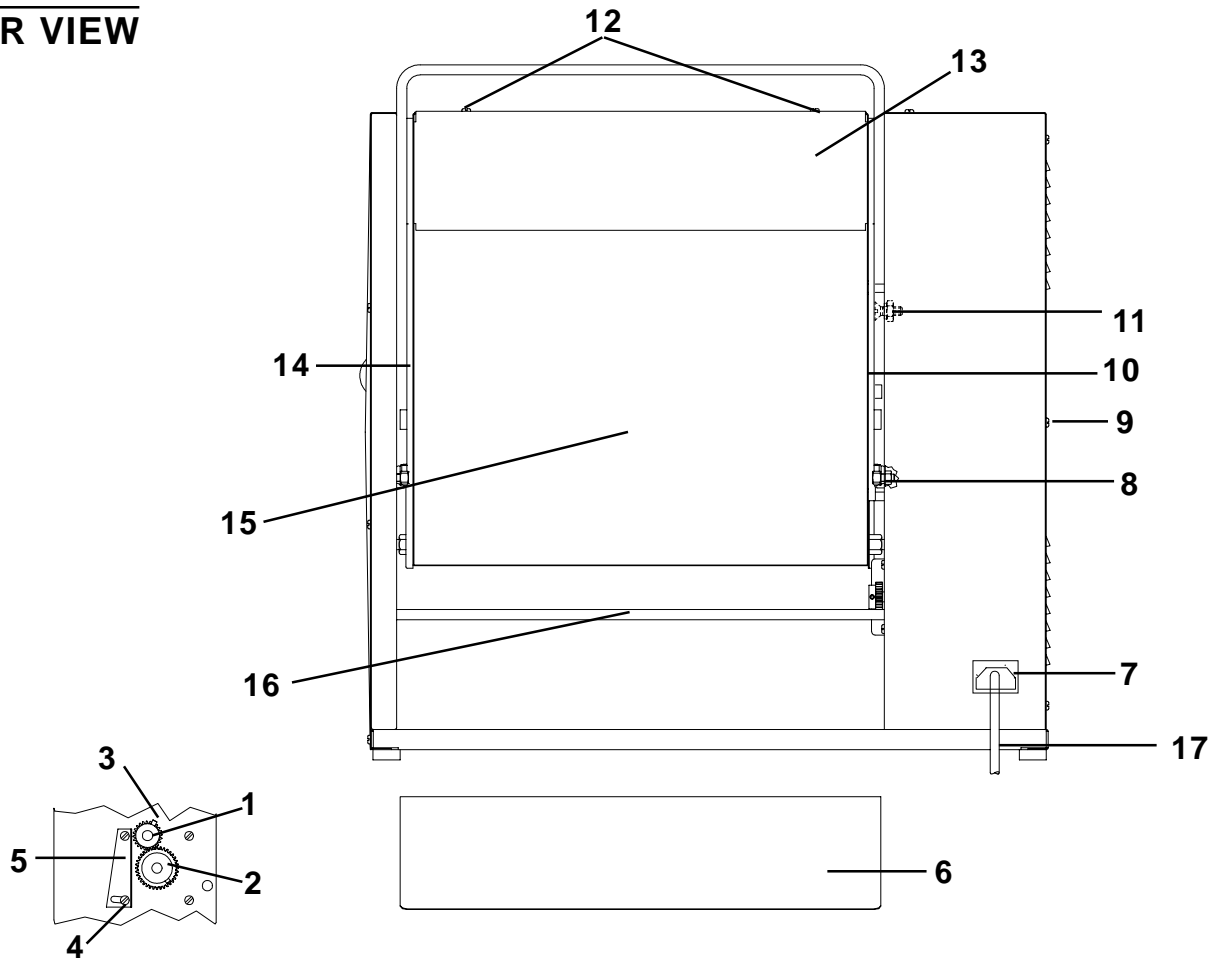

## PARTS LIST

Item	Part Number	Description
1	197-176	Small Gear 24 Teeth (196, 296, And 196-JACK)
	196-9	Small Gear 28 Teeth (196-SP)
2	197-177	Large Gear 36 Teeth (196,and 296)
	196-10	Large Gear 48 Teeth (196-SP and 196-JACK)
3	197-279	Pin
4	76-225	Slotted Pan Head Screw
5	197-131	Guard
6	197-33	Crumb Tray
7	88-591	Power Inlet
8	73-007	Hex Nut
	197-16	Conveyor Stop
	76-165	Set Screw
9	76-640	Screw
10	197-96	Left Side Bun Fence
11	73-008	Self Locking Hex Nut
	73-030	Hex Nut
	79-016	Flat Washer
	76-033	Slotted Flat Head Screw
12	76-640	Screw
13	197-13	Lead Pan Weldement
14	197-97	Right Bun Fence
15	196-1S	Platen
16	197-95	Tray Support
17	72-200-13S	Line Cord

## INTERNAL COMPONENTS

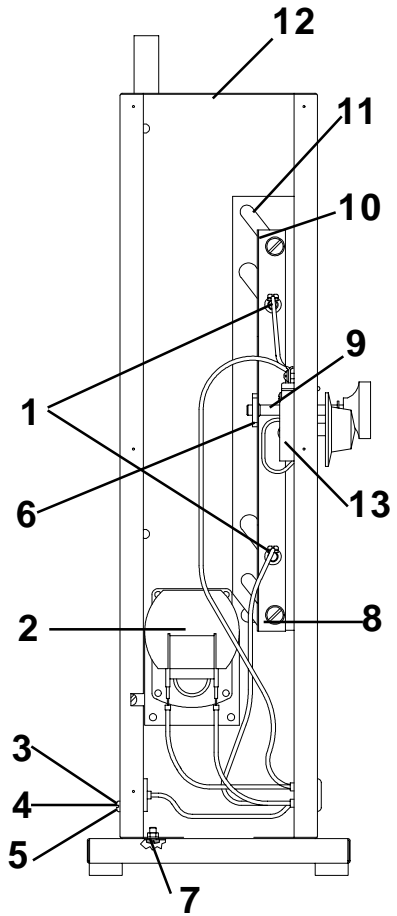

## PARTS LIST

Item	Part Number	Description
1	76-300	Slotted Pan Head Screw
2	87-029S	Motor (120 Volt)
3	73-031	Hex Nut
4	79-033	Washer
5	76-051	Slotted Binder Head Screw
6	79-055	Flat Washer
7	76-040	Slotted Binder Head Screw
	79-017	Split Lock Washer
	73-030	Hex Nut
8	76-150	Slotted Pan Head Screw
	79-094	Flat Washer
9	79-016	Flat Washer
	76-095	Slotted Binder Head Screw
10	197-90	L. H. Side Plate Weldement W/ Adjustment Screw
	197-89	R.H. Slide Plate Bracket W/Adjustment Screw
11	197-87	Baffle
12	197-371	Housing
13	197-140	Thermostat With Knob

## WIRING DIAGRAM

