

SOLID STATE DIGITAL ENERGY SAVING TOASTER  
PRINCE CASTLE MODEL NO. 213-SS SERIES



This equipment chapter is to be placed in the toasters section of your *Equipment Manual*.

**MANUFACTURED FOR  
MCDONALD'S®  
BY  
PRINCE CASTLE INC.  
355 KEHOE BLVD.  
CAROL STREAM, IL. 60188 USA  
PHONE 1-630-462-8800  
TOLL FREE NUMBER  
1-800-323-2930  
FAX:1-630-462-1460**



WARRANTY .....	Page 1
SIDE VIEW .....	Page 2
FRONT VIEW .....	Page 3
REAR VIEW .....	Page 3
INTERNAL VIEW .....	Page 4
EQUIPMENT SET-UP .....	Page 5
PROGRAMMING .....	Page 6
CLEANING .....	Page 8
TROUBLESHOOTING .....	Page 8
DIAGNOSTIC TROUBLESHOOTING .....	Page 9-11
TRANSLATIONS (FRENCH, GERMAN, SPANISH, ITALIAN) .....	Page 12-39
WIRING DIAGRAM .....	Page 40

### LIMITED WARRANTY

This product is warranted to be free from defects in material and/or workmanship for a period of (2) years from date of original installation not to exceed 30 months from date of shipment from our factory. Printed circuit boards and platen are warranted for a period of (3) years from date of original installation not to exceed 42 months from date of shipment from our factory. Any part or component which proves to be faulty in material and/or workmanship within the warranty period will be replaced or repaired without cost to the customer for parts or labor. (At the option of Prince Castle, Inc.)

This warranty is subject to the following exceptions/conditions:

- Any use of Non-genuine Prince Castle spare parts voids this warranty, and all work must be performed by an authorized Prince Castle Service Agent.
- All labor should be performed during regular working hours. Overtime premium will not be covered.
- Travel charges are limited to 100 miles (200 KM) round trip, 2 hours travel time, one trip per repair.
- Damage caused by carelessness, neglect, and/or abuse (e.g., using wrong current, dropping, tampering with or altering electrical components, or improper cleaning) is not covered.
- Equipment damaged in shipment, by fire, flood or an act of God.

This manual is for the exclusive use of licensees and employees of McDonald's Systems, Inc.

---

## SIDE VIEW

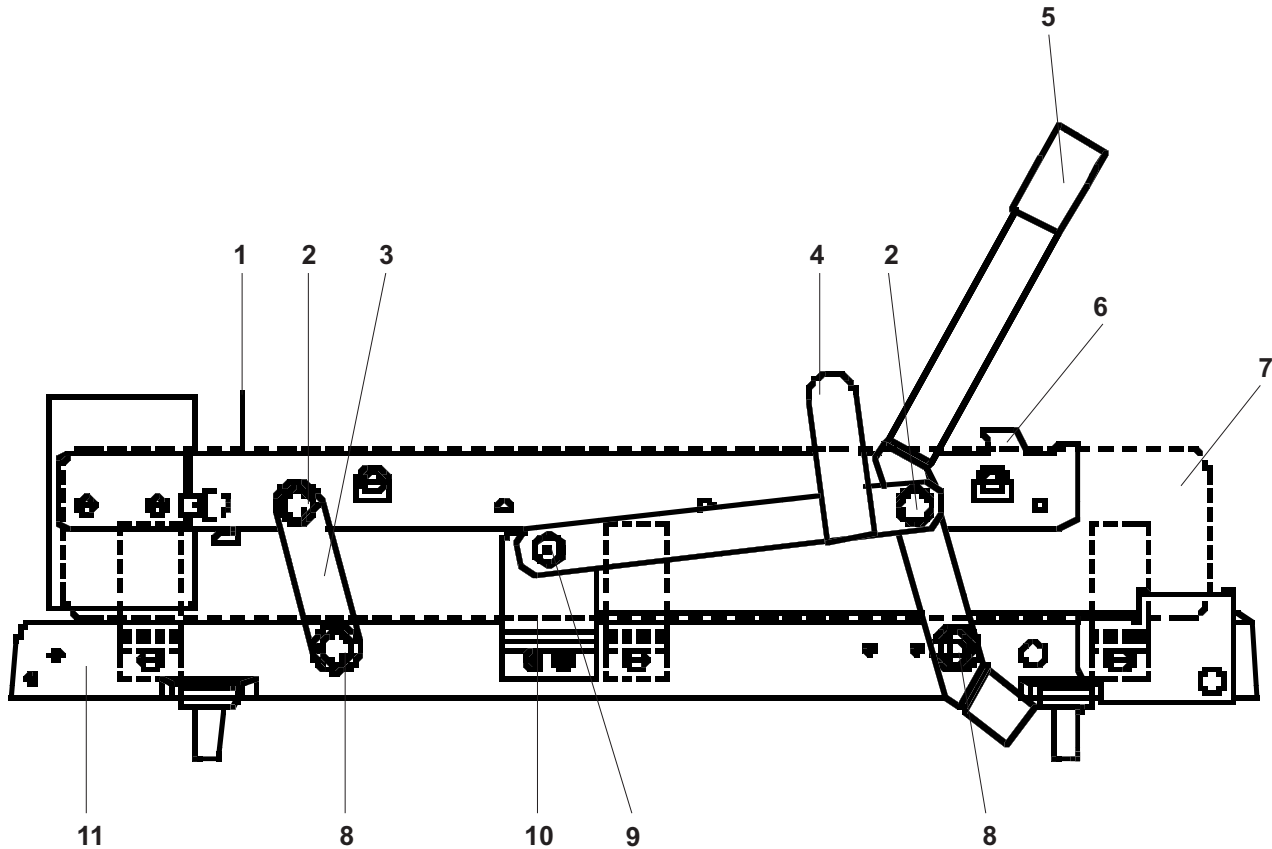

---

## PARTS LIST

ITEM	PART NUMBER	DESCRIPTION
1	213-651	Rear Bun Fence
2	212-285	Platen Stud, Rear
3	212-701S	Rear Lever Assy. Includes 62-005 Upper and 62-021 Lower Flange Barzns
4	213-303	Safety Latch
5	213-124	Handle and Lever Assy. w/Bearings
6	213-642	Left Hand Bun Fence
	213-644	Right Hand Bun Fence (Not shown)
7	213-416	Side Panel (Both Sides)
8	212-284	Base Studs
9	213-301	Safety Latch, Pivot Bolt
10	213-305	Safety Latch Bracket
11	213-413S	Base w/Feet

## FRONT VIEW

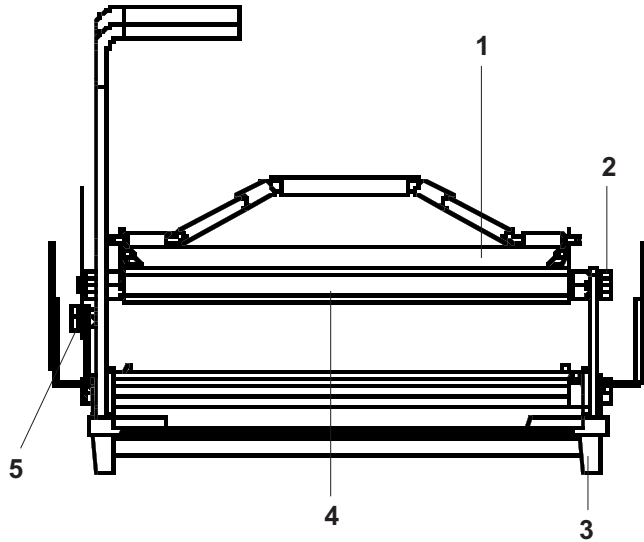

## PARTS LIST

ITEM	PART NUMBER	DESCRIPTION
1	213-673	Bun Board
	213-674	Bun Board for model 213-SFMNCE
2	212-286	Platen Stud, Front
3	89-959S	Black Rubber Foot (Pkg of 4)
4	213-84	Platen (230 V)
	213-83	Platen (120 V)
	213-85	Platen (200 V)
5	213-304	Platen Stud, Safety Latch
	(Not Shown) 212-331	Aluminum Plate (213-SAP, 213-SFAK, 213-SFLS, 213-SFMCE, 213-SFMNCE)

## REAR VIEW

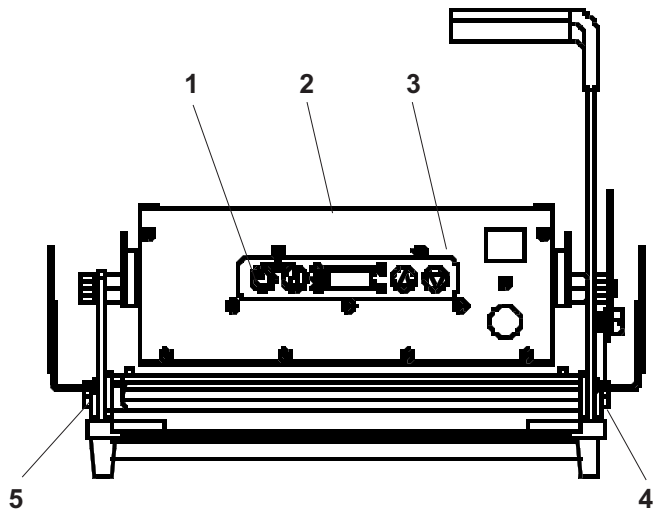

## PARTS LIST

ITEM	PART NUMBER	DESCRIPTION
1	411-707	Overlay
2	213-712	Cover
3	213-703	Face Plate
4	213-306	Left Hand Stop Block
5	213-307	Right Hand Stop Block
Not Shown	215-7	Spring, Extension
Not Shown	81-009	Spring, Compression

# INTERNAL VIEW UPPER CONTROL BOX

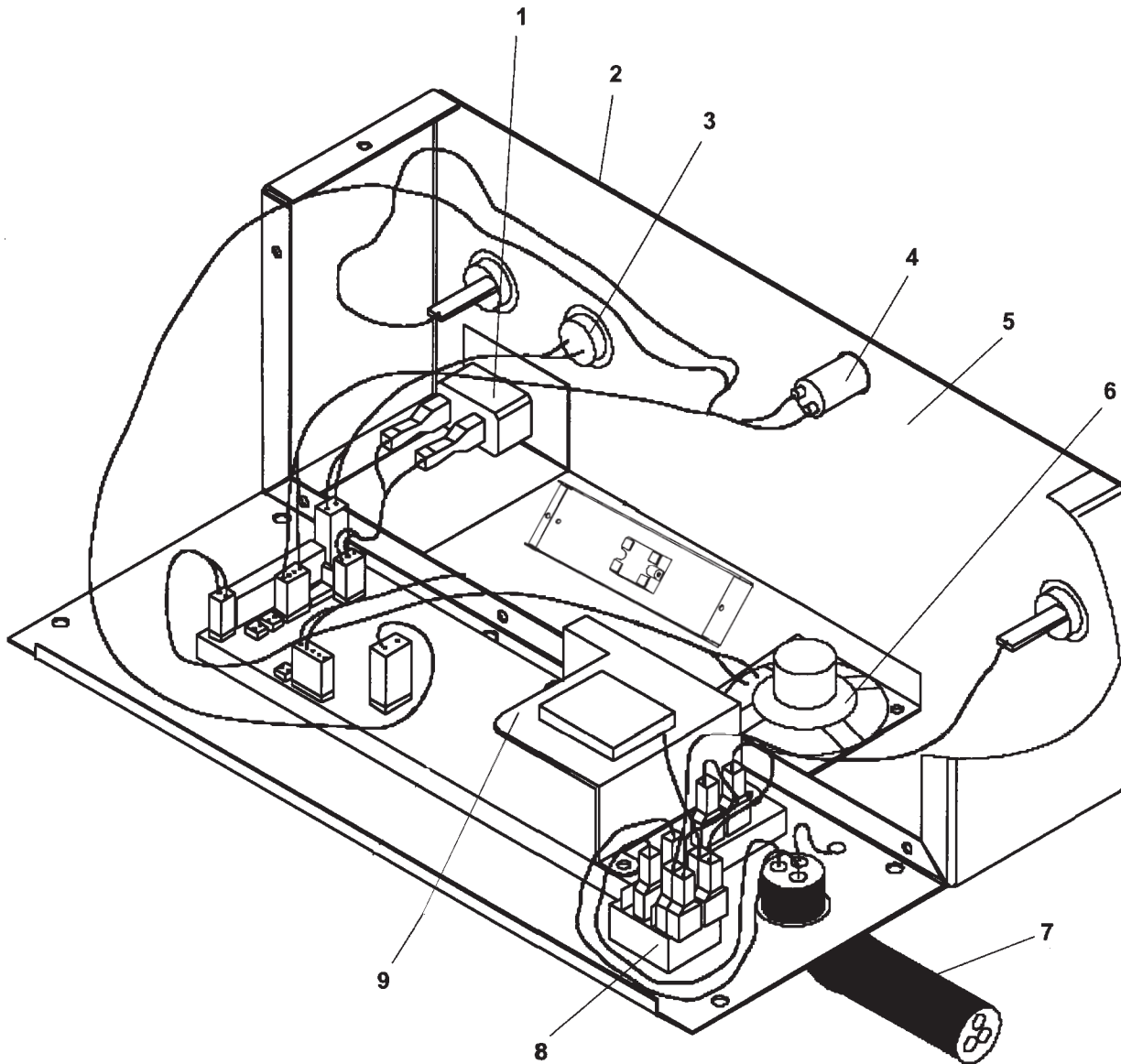

## PARTS LIST

ITEM	PART NUMBER	DESCRIPTION
------	-------------	-------------

1	78-146S	Timer Activating Switch
2	213-704	Chassis
3	213-700S	Temperature Probe
4	213-257S	Bun Done Light
5	65-058S	Relay
6	213-229S	Speaker Assy.
7	72-308S	Power Cord (213-S)
	72-309S	Power Cord (213-SP & 213-SAP)
	72-302	Power Cord (213-SFKS & 213-SFAK)
	72-299	Power Cord (213-SFLS)
	72-301S	Power Cord (213-SFMCE, 213-SFMSCE & 213-SFMNCE)
8	78-166S	Rocker Switch
9	411-427-04S	Control/Display PCB Assy. (230 V)
	411-750S	Control/Display PCB Assy. (110 V)

## SYMBOLS & TERMS

**C -- A** Toaster is set on Celsius.

**F -- A** Toaster is set on Fahrenheit.

**AL** - Alarm Level setting 1-4.



**Sound Button:** Used with timer button and temperature button to set alarm level.



**Timer Button:** Used to view time in run mode. Used to set time in program mode.



**Temperature Button:** Used to view set point temperature in run mode, and used to set the set point temperature in program mode.



**Up Arrow:** Used to set time, sound and temperature in program mode.



**Down Arrow:** Used to set time, sound, and temperature in program mode.

## FACTORY PRE-SET

Prince Castle s Solid State Digital Display toasters are pre-set at the factory.

If your toaster model is set for a 35 second toast time, then the temperature is pre-set and calibrated to 419°F 215°C.

If your toaster model is set for a 55 second toast time, then the temperature is pre-set and calibrated to 400° F 204°C.

## SET-UP

1. Refer to the nameplate on the control box for the proper operating voltage. Connect the toaster to a grounded receptacle that matches the nameplate voltage information. Press the power switch to the on position, allow the unit 30 minutes to reach operating temperature.
2. The toaster is factory-set to display temperatures reading in Celsius. When the toaster is turned on, the digital display on the control box will read C--A for Celsius, and the **A** will begin to count down 9 seconds. During this countdown, you can change the temperature display from Celsius to Fahrenheit readings. To change temperature display, press and hold the temperature button for six seconds. See figure 1.

figure 1

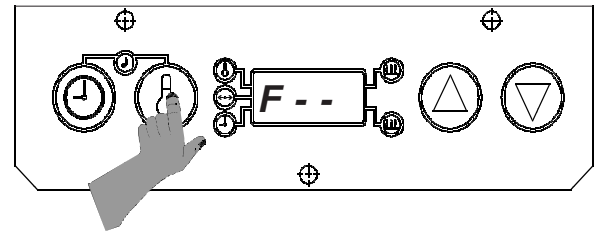

3. During the pre-heat cycle, the display will read **LO-**. When the platen temperature reaches 149° C (300° F), the display will begin to show the actual platen temperatures throughout the toasting cycles. See figure 2.

figure 2

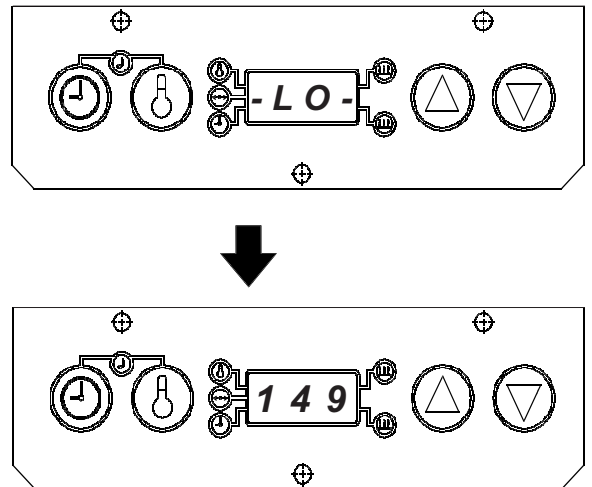

## Sound Level Adjustment



The audio alarm has four sound levels.

1. Press and hold the time button and temperature buttons simultaneously. The display will show the current sound level. The toasters are factory set at level 4, and the display will read, **AL 4** for Alarm Level 4. See figure 3.

figure 3

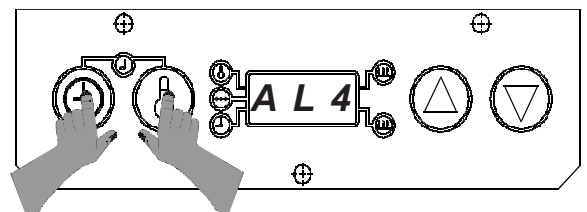

- While holding the time and temperature buttons, press the up or down arrow buttons to adjust the sound level. A continuous tone will sound. Release all buttons when the desired sound level is reached. The display will show the current sound level. See figure 4.

figure 4

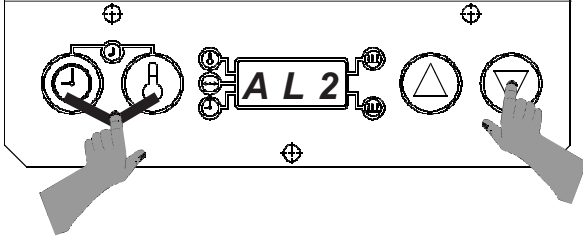

### VIEW SET POINT TEMPERATURE

- Press and release the temperature button. (Do not hold for more than 6 seconds.) A beep will sound, the temperature indicator will turn on, and the display will show the set point temperature for three seconds. The display will then change to show the actual temperature. See figure 5.

figure 5

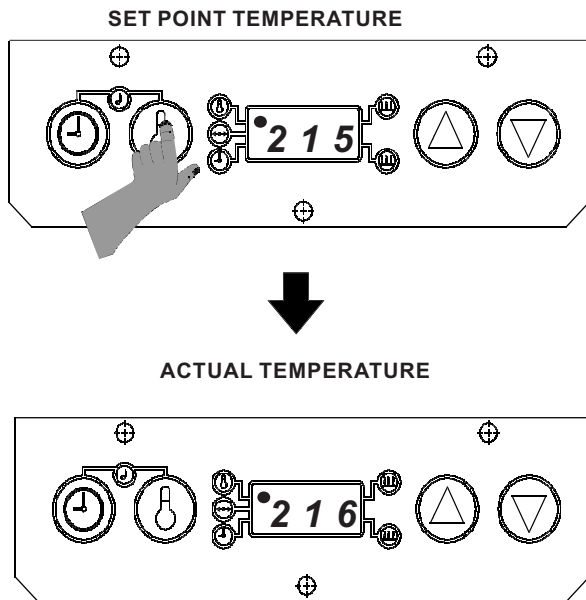

### VIEW TIMER SETTING

- Press and release the time button. (Do not press the time button for more than 6 seconds.) The set time will be displayed for three seconds. If the timer is activated and is in a countdown sequence, the time remaining will be displayed, and will continue to countdown to zero. After three seconds, the display will change to show actual platen temperature. See figure 6.

figure 6

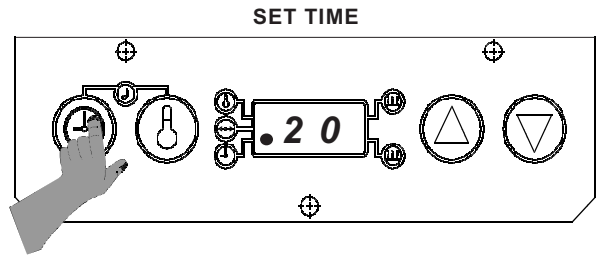

## PROGRAMMING

The programming modes are used for setting individual set point temperature, and setting toast times.

### Programming the Set Point Temperature

- Press and hold the temperature button for six seconds. A beep will sound, the temperature indicator light will blink, and the display will show the current set point temperature. See figure 7.

figure 7

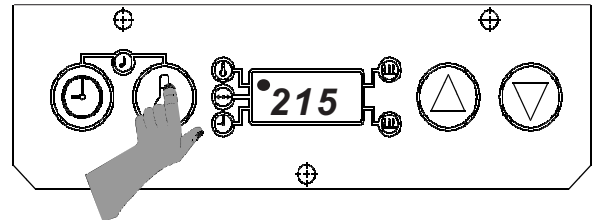

- To change the set point temperature, use the up or down arrow. Once the desired temperature is displayed, press the temperature button to store the new setting. See figure 8.

figure 8

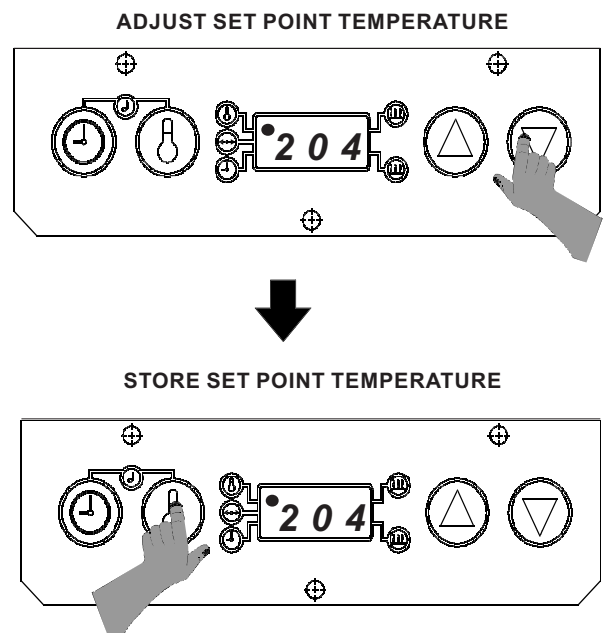

3. To cancel the set point programming mode at any time, press and release the time button. The display will change to show the actual platen temperature. See figure 9.

figure 9

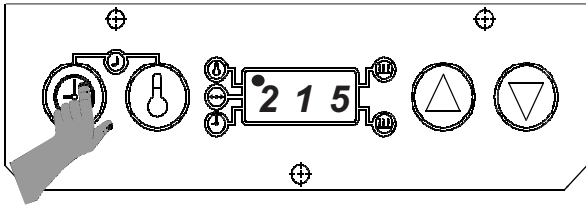

### Programming Toast Times

1. Press and hold the time button for 6 seconds. A beep will sound, and the time indicator light will blink. Release the time button to show the current toast time. See figure 10.

figure 10

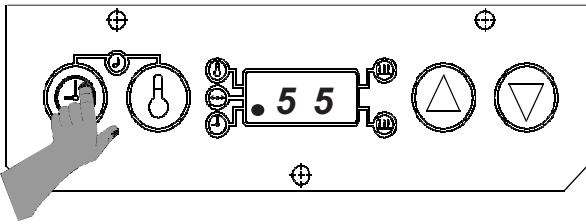

2. Use the up and down arrow buttons to set your desired toast time. The range is from 20 seconds to 1 minute, 30 seconds. When desired time is reached, press and release the time button to store the new time. See figure 11.

figure 11

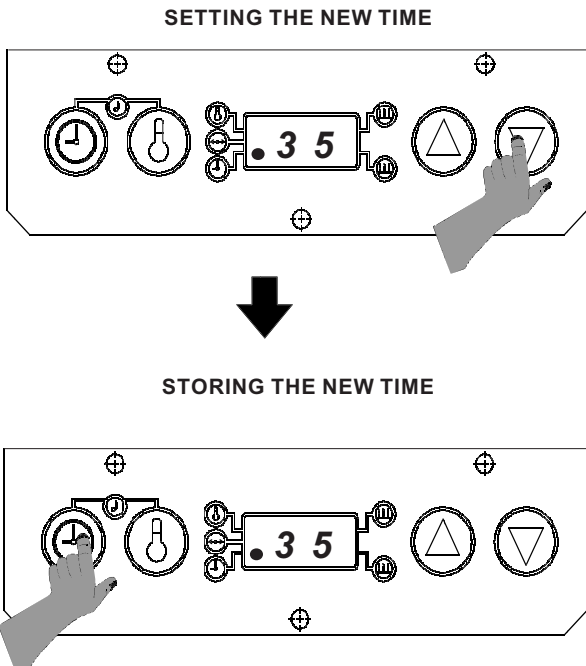

3. To cancel the time set function at any time, press and release the temperature button. The time indicator light will turn off, and the display will change to show the actual platen temperature. See figure 12.

figure 12

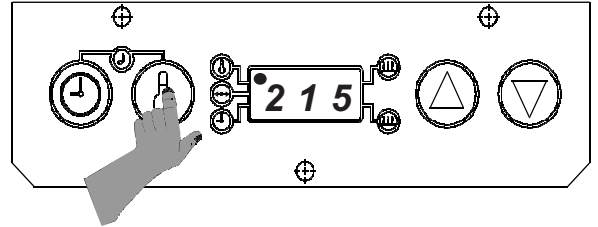

### ENERGY SAVING MODE

To conserve energy during non-toasting periods, pull the toaster handle down, so that the timing cycle activates. When the audio alarm goes off, indicating that the toasting time is complete, **DO NOT** pull the handle up. Allow the audio alarm to sound until the alarm shuts off, the display will alternately flash **Stand** and **By, indicating** the toaster is in the energy savings mode. The toaster platens will continue to maintain the programmed operating temperature, raising the toaster handle will put the toaster back into the operation mode.

### SETTING STOP BLOCKS

Stop blocks allow for proper crush when toasting buns. The toaster leaves the factory with the stop blocks set on number 3. The stop blocks are located toward the front of the toaster on the right and left sides of the base. To increase the crush, set the stop blocks to the number 2 setting. To decrease the crush, set the stop block to the number 4 setting. See figure 13.

figure 13

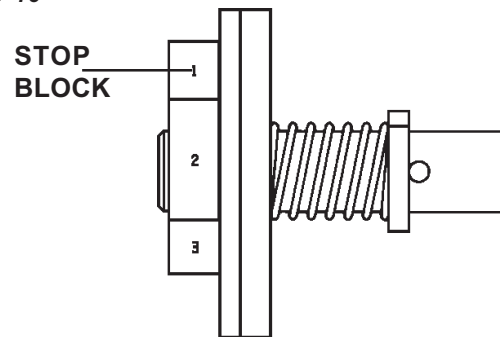

**IMPORTANT:** The stop blocks are set at the number that is touching the lever. The example in figure 13 shows a stop block setting of 1.

1. To change the stop block setting, depress the right stop block and disengage the locking pin. Turn stop block to correct setting.

## CLEANING

1. Press the power switch to the off position.
2. Unplug toaster.
3. Allow toaster and platens to cool down.
4. Wipe entire platen with clean, damp grill cloth.  
Full toaster cleaning must be done in the morning when toaster is cold. See your *Planned Maintenance Card* for proper cleaning procedures.

**IMPORTANT:** Do not drape cord over hot toaster bun board or platen. This will cause cord to burn.

## TROUBLESHOOTING GUIDE

PROBLEM	CAUSE	SOLUTION
Platen loose.	Platen bolts loose.	Tighten platen bolts.
Speaker sounds, but no bun done light comes on.	Done light burned out.	Replace done light.
No speaker sounds and bun done light does not come on.	Defective timer switch. Timer connection shorted on power board. Timer switch not activating.	Replace timer switch. Replace power board.  Check actuating bracket to make sure it pushes timer switch all the way in.
Buns being crushed.	Stop blocks not adjusted properly. Warped bun trays.  Buns cut improperly.	Adjust stop blocks.  Straighten or replace bun trays. Contact bakery.
Platen does not heat.	No power. Power switch defective. Shorted power board. Platen burned out or shorted.	Check power source. Replace power switch. Replace power board. Check platen with ohmmeter for 11 ohms, if reading is less than 7 ohms or more than 14 ohms, replace platen.
No Display.	Fuse Defective.	Check fuse with ohmmeter, reading should be 1-2 ohms.



# WIRING DIAGRAM

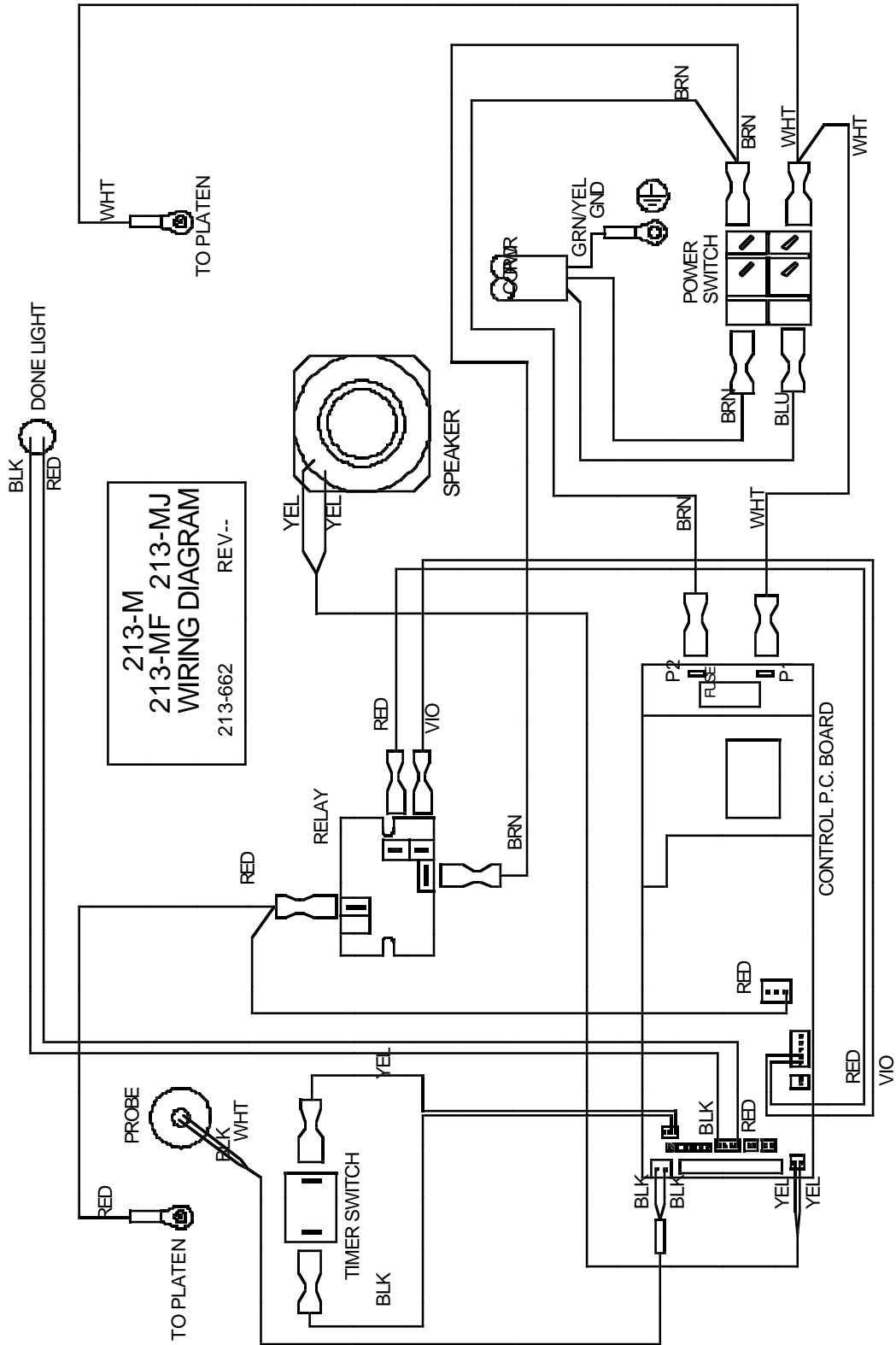



固态数字烤箱  
PRINCE CASTLE 型号 213-SS 系列

有关此设备的说明，请参阅《设备手册》中的烤箱部分。

**PRINCE CASTLE INC.**  
**为 MCDONALD'S® 专门制造**

**PRINCE CASTLE INC.**  
**355 KEHOE BLVD.**  
**CAROL STREAM, IL.60188 USA**  
**电话: 1-630-462-8800**  
**全美免费电话: 1-800-323-2930**  
**传真: 1-630-462-1460**



担保.....	第 1 页
电气规范/侧视图.....	第 2 页
正视图.....	第 3 页
后视图.....	第 3 页
内部视图.....	第 4 页
设备安装.....	第 5 页
编程.....	第 6 页
清洁.....	第 8 页
故障排除.....	第 8 页
诊断故障排除.....	第 9-11 页
译文 (法语、德语、西班牙语、意大利语).....	第 12-39 页
布线图.....	第 40 页

### 有限担保

此产品担保从最初安装（不得超过出厂日期 30 个月）之日起的 2 年之内，不会存在材料和/或工艺方面的缺陷。印刷电路板和滚筒的担保期限为从最初安装（不得超过出厂日期 42 个月）之日起的 3 年内。在担保期限内，任何零件或组件一旦出现材料和/或工艺等故障，均将得到更换或修理服务，而不会向客户收取任何零件或人工费。（具体服务由 Prince Castle, Inc. 决定）

- 使用非原装的 Prince Castle 机器备件将使此担保失效，同时所有担保工作都必须由授权的 Prince Castle 服务代理机构执行。
- 所有工作都应在正常的工作时间内执行。不包括任何超时费用。
- 每次外出修理的差旅费用限制在往返旅程 100 英里（200 公里）之内，时间限制为 2 小时。
- 因粗心大意、疏忽和/或违规操作（例如使用错误的电流、跌落、改动或修改电气元件或不正确的清洁操作）导致的任何损坏，均不在担保范围之列。
- 发运时因火灾、洪水或任何不可抗力导致的设备损坏。

此手册专门为 McDonald's Systems, Inc. 的特许经销商和员工编写。

## 侧视图

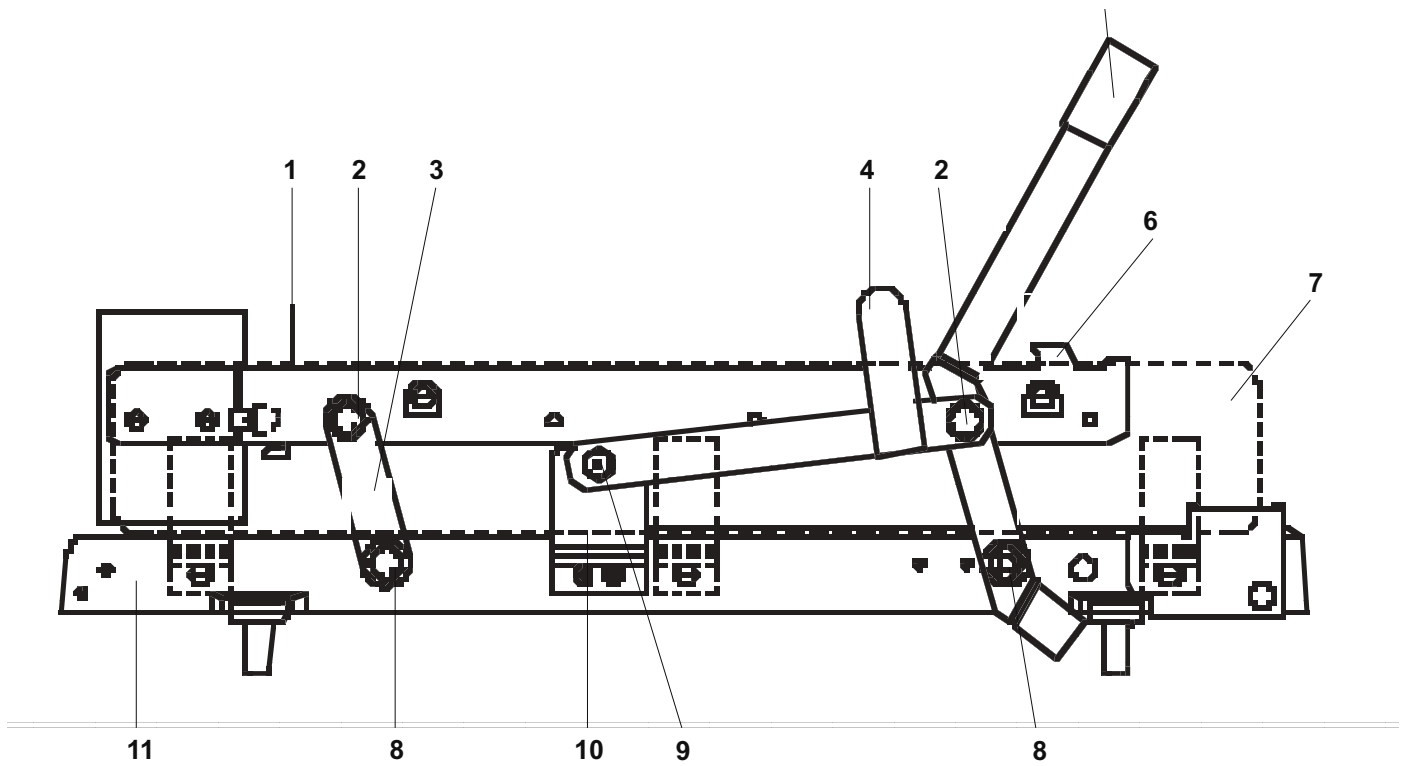

## 零件列表

项目	零件号	说明
1	213-651	背面的面包烤栏
2	212-285	滚筒螺栓, 背面
3	212-701S	背面的杠杆装置包括 62-005 (上部) 和 62-021 (下部) 法兰盘
4	213-303	安全锁
5	213-124	手柄和杠杆装置, 带轴承
6	213-642	左侧面包烤栏
	213-644	右侧面包烤栏 (未显示)
7	213-416	侧面板 (两侧)
8	212-284	底座螺栓
9	213-301	安全锁, 中枢螺栓
10	213-305	安全锁托架
11	213-413S	底座, 带支腿

## 正视图

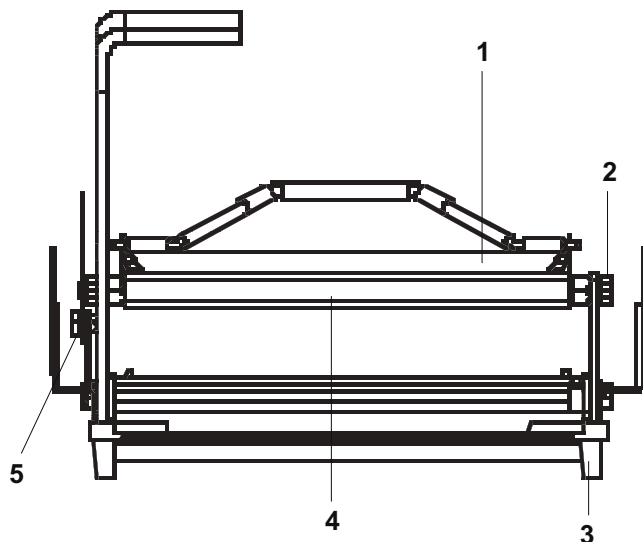

## 零件列表

项目	零件号	说明
1	213-673 213-674	面包盘 用于型号 213-SFMNCE 的面包盘
2	212-286	滚筒螺栓, 正面
3	89-959S	黑色橡胶支腿 (4 个)
4	213-84 213-83 213-85	滚筒 (230 V) 滚筒 (120 V) 滚筒 (200 V)
5	213-304	滚筒螺栓, 安全锁
未显示	212-331	铝盘 (213-SAP、 213-SFAK、213-SFLS、 213-SFMCE、 213-SFMNCE)

## 后视图

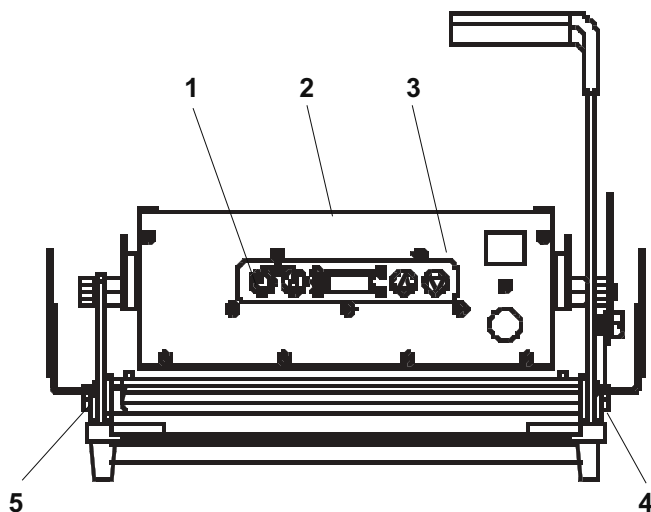

## 零件列表

项目	零件号	说明
1	411-707	涂层
2	213-712	外壳
3	213-703	面板
4	213-306	左侧限位装置
5	213-307	右侧限位装置
未显示	215-7	弹簧, 伸展
未显示	81-009	弹簧, 收缩

## 内部视图上控制箱

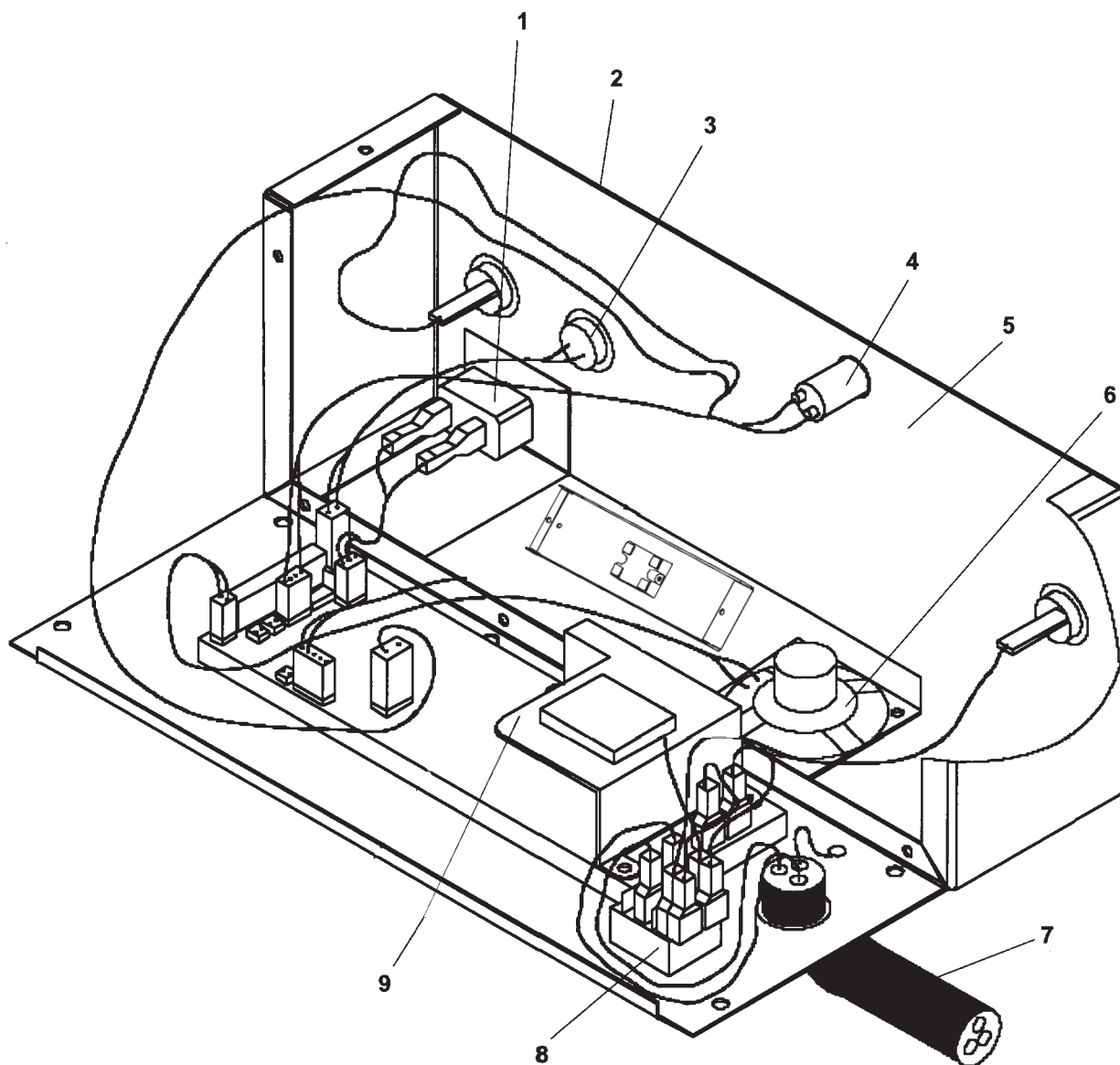

### 零件列表

项目	零件号	说明
1	78-146S	计时器激活开关
2	213-704	机箱
3	213-700S	温度探测器
4	213-257S	面包烘烤完成指示灯
5	65-058S	继电器
6	213-229S	扬声器装置
7	72-308S	电源线 (213-S)
	72-309S	电源线 (213-SP 和 213-SAP)
	72-302	电源线 (213-SFKS 和 213-SFAK)
	72-299	电源线 (213-SFSL)
	72-301S	电源线 (213-SFMCE、213-SFMSCE 和 213-SFMNCE)
8	78-166S	摇臂开关
9	411-427-04S	控制/显示 PCB 装置 (230 V)
	411-750S	控制/显示 PCB 装置 (110 V)

## 符号和术语

**C--A** 烤箱设置为摄氏温度。

**F--A** 烤箱设置为华氏温度。

**AL-** 警报级别设置 1-4。



声音按钮：配合计时器按钮和温度按钮使用，以设置警报级别。



计时器按钮：用于在运行模式下查看时间。用于在程序模式下设置时间。



温度按钮：用于在运行模式下查看设置点温度，并且用于在程序模式下设置设置点温度。



向上箭头：用于在程序模式下设置时间、声音和温度。



向下箭头：用于在程序模式下设置时间、声音和温度。

## 出厂预设

Prince Castle 的固态数字显示烤箱在出厂时已经过预设。

如果烤箱的烘烤时间被设置为 35 秒，则表明温度被预设并校准为 419°F (215°C)。

如果烤箱的烘烤时间被设置为 55 秒，则表明温度被预设并校准为 400°F (204°C)。

## 安装

1. 请参阅控制箱上的铭牌，了解正确的操作电压。请将烤箱连接至接地的插座，插座应与铭牌上的电压信息相吻合。将电源开关按下至“打开”位置，使设备在 30 分钟之内达到操作温度。
2. 烤箱在出厂时设置为以摄氏温度显示温度读数。打开烤箱时，控制箱上的数字显示屏显示 **C--A**（代表摄氏温度），并且 **A** 开始倒计时 9 秒钟。在倒计时期间，可将温度显示从摄氏温度更改为华氏温度读数。要更改温度显示，请按下并按住温度按钮六秒钟。请参见图 1。

图 1

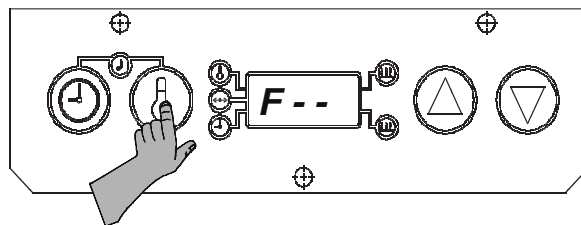

3. 在预热周期中，显示屏将显示 **-LO-**。当滚筒温度达到 149°C (300°F) 时，显示屏开始显示烘烤周期的实际滚筒温度。请参见图 2。

图 2

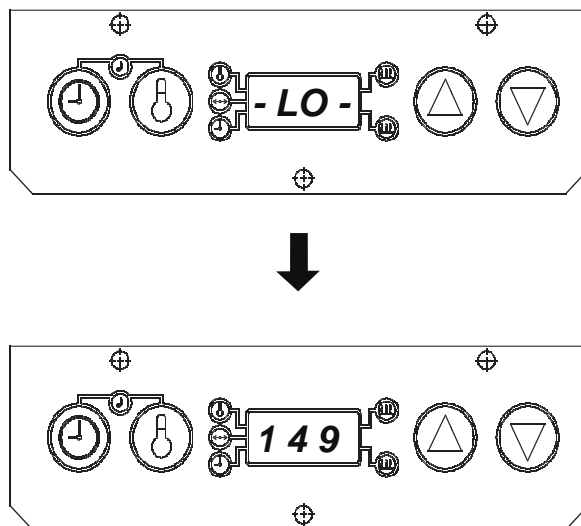

### 声音级别调整



音频警报包含四种声音级别。

1. 同时按下并按住时间按钮和温度按钮。显示屏将显示当前的声音级别。烤箱在出厂时设置为第 4 级别，显示屏将显示 **AL4**（代表警报级别 4）。请参见图 3。

图 3

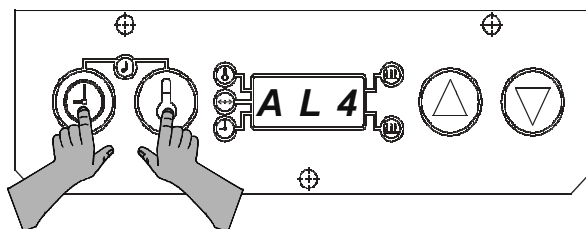

- 按住时间和温度按钮的同时，请按向上或向下箭头按钮调整声音级别。烤箱将发出连续的提示音。到达所需的声音级别时，请释放所有按钮。显示屏将显示当前的声音级别。请参见图 4。

图 4

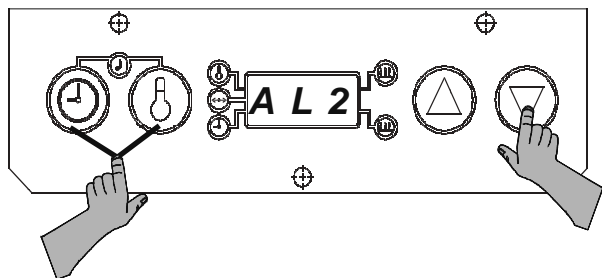

### 查看设置点温度

- 按下然后释放温度按钮。（按下按钮的时间不要超过 6 秒）。此时烤箱将发出“嘟”的一声，温度指示器将打开，并且显示屏将显示设置点的温度三秒钟。然后，显示屏将显示实际的温度。请参见图 5。

图 5

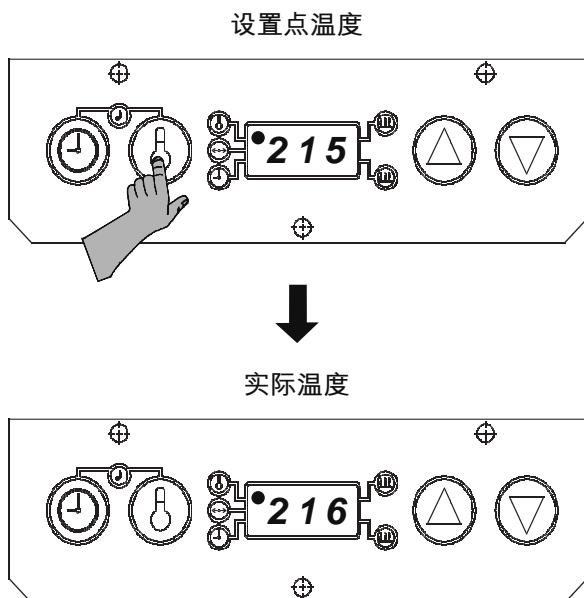

### 查看计时器设置

- 按下然后释放时间按钮。（按下时间按钮的时间不要超过 6 秒）。设置时间将显示三秒钟。如果计时器被激活并处于倒计时序列中，则将显示剩余时间，并且将继续倒计时到零。三秒钟后，显示屏将显示实际的滚筒温度。请参见图 6。

图 6

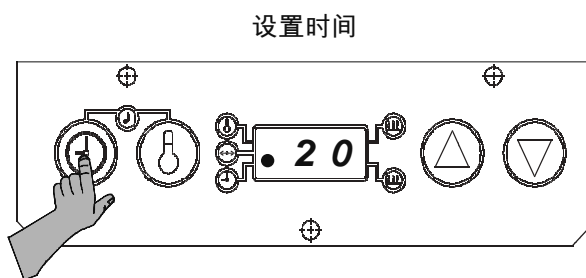

## 编程

编程模式用于设置单独的设置点温度，以及设置烘烤时间。

### 设置点温度编程

- 按下并按住温度按钮六秒钟。此时烤箱将发出“嘟”的一声，温度指示灯将闪烁，并且显示屏将显示当前设置点温度。请参见图 7。

图 7

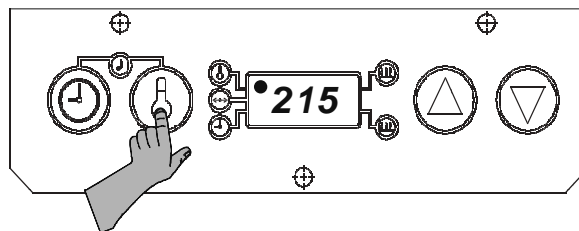

- 要更改设置点温度，请使用向上或向下箭头。显示所需的温度后，请按下温度按钮，存储新的设置。请参见图 8。

图 7

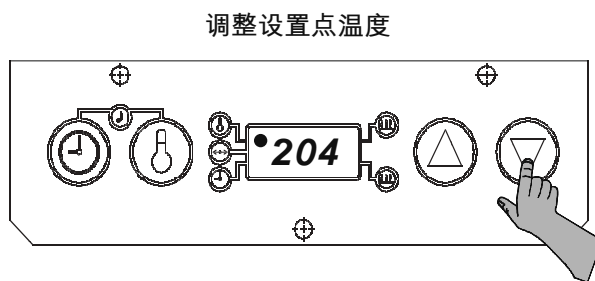

### 存储设置点温度

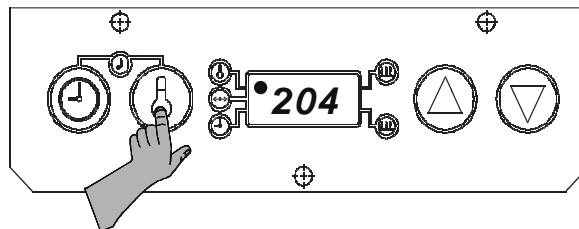

- 要随时取消设置点温度编程模式，请按下然后释放时间按钮。显示屏将显示实际的滚筒温度。请参见图 9。

图 9

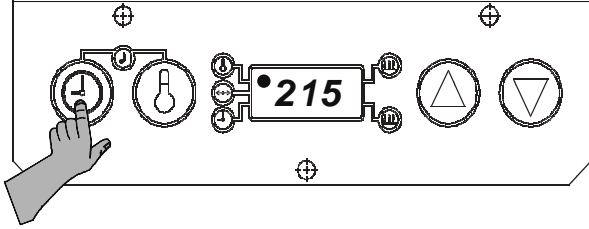

### 烘烤时间编程

- 按下并按住时间按钮 6 秒钟。此时烤箱将发出“嘟”的一声，并且时间指示灯将闪烁。释放时间按钮，以显示当前烘烤时间。请参见图 10。

图 10

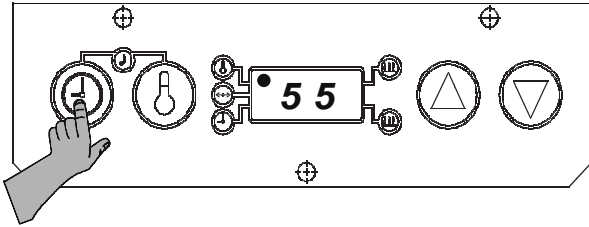

- 使用向上和向下箭头按钮设置所需的烘烤时间。时间范围从 20 秒到 1 分 30 秒。到达所需时间后，请按下然后释放时间按钮，以存储新的时间。请参见图 11。

图 11

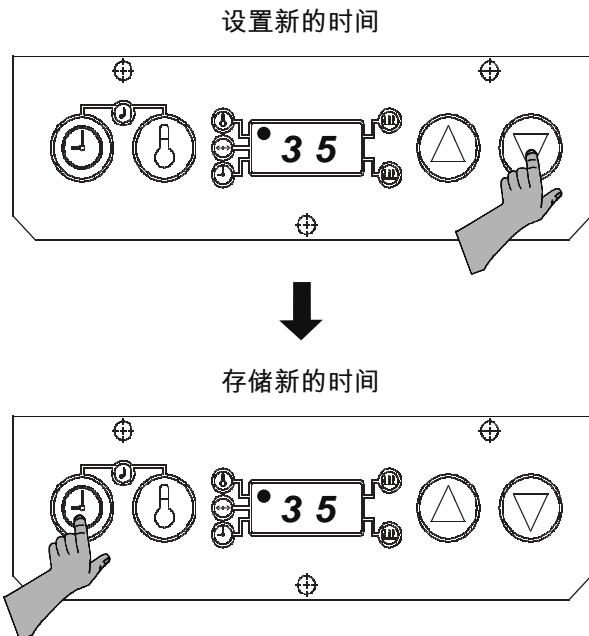

- 要随时取消时间设置功能，请按下然后释放温度按钮。时间指示灯将关闭，并且显示屏将显示实际的滚筒温度。请参见图 12。

图 12

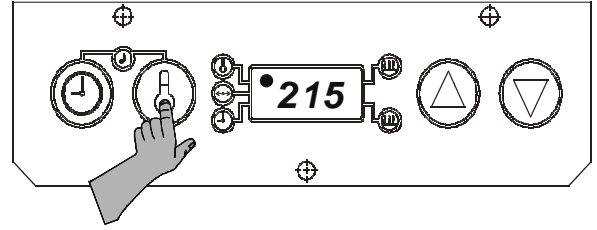

### 节能模式

为在不烘烤期间节省能源，请向下拉动烤箱手柄，从而激活定时周期。如果音频警报消失，则表明烘烤时间已结束，**请不要**向上拉动手柄。允许音频警报发出声音，直到警报关闭，显示屏将交替闪烁 **Stand** 和 **By**，指示烤箱处于节能模式。烤箱滚筒将持续保持编程的操作温度，抬起烤箱的手柄会将烤箱恢复操作模式。

### 设置限位装置

限位装置可以在烘烤面包的同时进行适当的碾压。烤箱在出厂时的限位装置设置为 3。限位装置位于接近烤箱的正前方，底座的左右两侧。要增加碾压力度，请将限位装置设置为 2。要降低碾压力度，请将限位装置设置为 4。请参见图 13。

**重要说明：**限位装置的编号级别与杠杆吻合。图 13 中的示例显示限位装置设置为 1。

- 要更改限位装置设置，请向下按压正确的限位装置，然后松开锁定销。将限位装置调整至正确的设置。

图 13

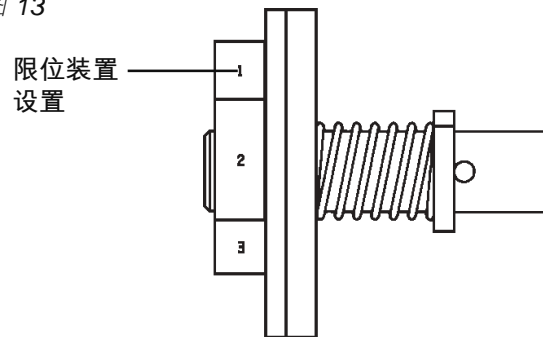

**重要说明：**限位装置的编号级别与杠杆吻合。图 13 中的示例显示限位装置设置为 1。

- 要更改限位装置设置，请向下按压正确的限位装置，然后松开锁定销。将限位装置调整至正确的设置。



## 清洁

1. 按下电源开关至“关闭”位置。
2. 拔下烤箱的电源插销。
3. 让烤箱和滚筒冷却。
4. 使用清洁、潮湿的烤箱专用抹布擦拭整个滚筒。必须利用早晨烤箱冷却的时间，完成整个烤箱的清洁工作。有关正确清洁过程，请参见计划维护卡。

**重要说明：**请不要将电线悬挂在高温烤箱面包盘或滚筒上方。这样会导致电线燃烧。

## 故障排除指南

问题	原因	解决方案
滚筒松动。	滚筒螺栓松动。	拧紧滚筒螺栓。
扬声器发出声音，但是面包烘烤完成指示灯不亮。	烘烤完成指示灯烧坏。	更换烘烤完成指示灯。
扬声器不发声，并且面包烘烤完成指示灯也不亮。	计时器开关出现故障。 配电板上的计时器连线短路。 计时器开关没有激活。	更换计时器开关。 更换配电板。 检查启动支架，确保将计时器开关完全推入到位。
面包被碾碎。	限位装置调节不正确。 面包盘变形。 面包切割不正确。	调整限位装置。 弄直或更换面包盘。 与面包店联系。
滚筒不热。	没有电。 电源开关出现故障。 配电板短路。 滚筒烧坏或短路。	检查电源。 更换电源开关。 更换配电板。 使用欧姆表检查滚筒是否显示 <b>11 欧姆</b> ，如果读数小于 <b>7 欧姆</b> 或大于 <b>14 欧姆</b> ，请更换滚筒。
无显示。	保险丝出现故障。	使用欧姆表检查保险丝，读数应为 <b>1-2 欧姆</b> 。

