

OPERATING INSTRUCTIONS

PRINCE CASTLE INC. 

Slim-Line Vertical Bun Toaster Model No. 197-FCE, 297-FGB, 297-FCE & 297-FGB

Excalibur 



NSF CE

Prince Castle's 197/297 Series Slim-Line Bun Toaster provides perfect contact toasting. With adjustable bun thickness controls and an adjustable thermostat, the model 197 toasts up to 720 buns per hour and the model 297 toasts up to 1400 buns per hour.

PRODUCT SPECIFICATIONS

Electrical:

Volts	Hz	Watts	KW	Amps
230	50	1700	1.7	6.5

TABLE OF CONTENTS

PAGE

Installation	2
Operation	2
Adjustments and Cleaning	3-4
Translations (French, German, Spanish, Italian)	5-12
Troubleshooting	13
Parts List	13-16
Wiring Diagram	16

LIMITED WARRANTY

This product is warranted to be free from defects in material and/or workmanship for a period of two (2) years from date of original installation, not to exceed 30 months from date of shipment from our factory. Any part or component which proves to be faulty in material and/or workmanship within the warranty period will be replaced or repaired (at the option of Prince Castle, Inc.) without cost to the customer for parts or labor

This warranty is subject to the following exceptions/conditions:

- Service must be performed by an authorized Prince Castle Service Center.
- Any use of non-genuine Prince Castle spare parts voids this warranty.
- This equipment is portable. Charges for on location service (e.g. trip charges, mileage) are only included in the provisions of this warranty for a failure which occurs within 30 days of installation.
- All labor shall be performed during regular working hours. Overtime premium will not be covered.
- Damage caused by carelessness, neglect, and/or abuse (e.g., using wrong current, dropping, tampering with or altering electrical components, or improper cleaning) is not covered by the terms of this warranty. Equipment damaged in shipment, by fire, flood or an act of God is not covered.
- Normal adjustments as outlined in this manual are not covered under warranty.

PRINCE CASTLE INC. 

355 East Kehoe Blvd. • Carol Stream, IL 60188

Tel: (630) 462-8800 • Fax: (630) 462-1460

Toll Free: 1-800-PCASTLE

INSTALLATION

- After you have removed the toaster from the carton, inspect the unit for signs of damage. If there is damage to the unit:
 - Notify carrier within 24 hours after delivery.
 - Save carton and packing material for inspection purposes.
 - Contact the Prince Castle Customer Sales Department at 1-800-722-7853 to arrange for a replacement to be sent.
- Verify that all parts have been received.
 - Slim-Line Bun Toaster and conveyor assembly.
 - Line Cord—packed separately from the toaster and is located at the bottom of the box.
 - Release Sheets—located in a 14" box.
 - Crumb Tray—taped to the front of the conveyor.
- Place toaster on flat surface.
- Lift conveyor off conveyor guide rails and set aside. Remove all packing materials (nylon tape, foam block and black rubber packaging spacers) from conveyor and conveyor guides. See figure 1.

figure 1

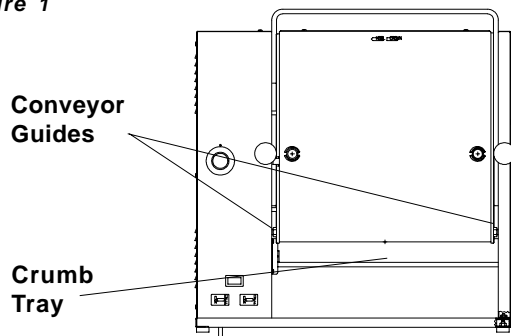

- Attach conveyor to the toaster by sliding the four pins (conveyor slides) on the conveyor housing into the four conveyor guides. Lower the conveyor housing until it is securely in place. See figure 2.

figure 2

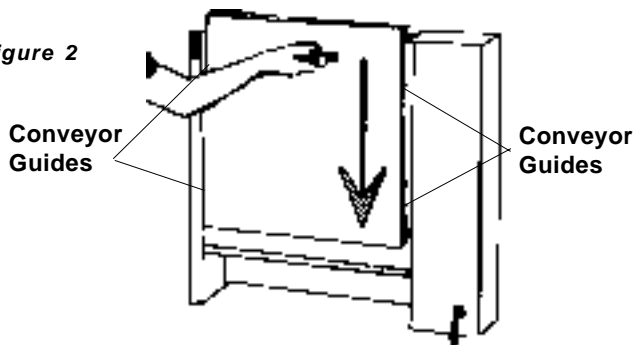

- Connect line cord and plug unit into a 230 volt grounded receptacle.

OPERATION

- Place the release sheet over the top of the platen housing, making sure to have three inches of overhang. See figure 3.

figure 3

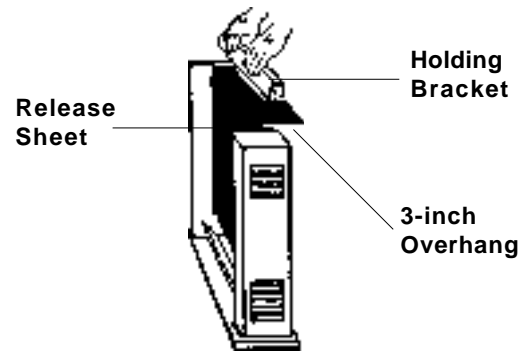

- Slide the release sheet holding bracket onto the top of the platen housing to securely hold the release sheet in place. Match the **FRONT** of the labeled bracket with the front of the platen. See figure 3.
- Hook back end of crumb tray onto the bar located below the conveyor assembly.
- Attach conveyor to the toaster. See figure 2.
- Turn the heater switch to the "On" position. The orange indicator light will illuminate. Allow 30 minutes for platen to reach operating temperature. See figure 4.

figure 4

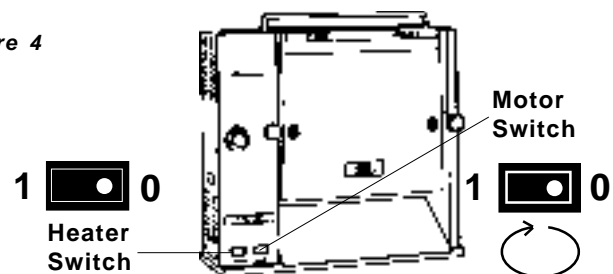

- Turn the motor switch to the "On" position. The orange indicator light will illuminate. See figure 4. Conveyor chain will begin to rotate.

IMPORTANT: To conserve energy when toaster is not in use, turn the motor switch "Off".

- Place a sample run of the product being toasted into the top of the conveyor housing. The side to be toasted should face the platen. See figure 5.

figure 5

- The toasted product will be dispensed automatically from the bottom of the conveyor assembly. The toasting cycle is 30-35 seconds on model 197 and 15-18 seconds on model 297.

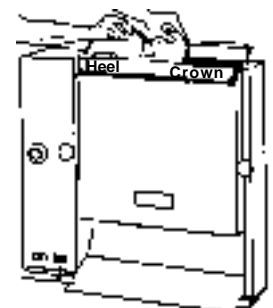

ADJUSTMENTS

Bun Compression:

The toaster platen can be adjusted to provide the necessary compression needed on various products.

- Turn the two platen adjustment knobs clockwise to compensate for use on thicker bread products. Turn the two platen adjustment knobs counter clockwise for thinner products. See figure 6.

figure 6

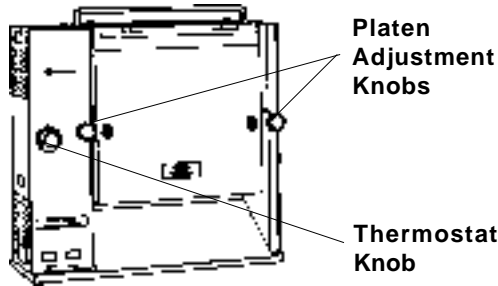

Platen Temperature:

The temperature of the platen can be adjusted to compensate for darker or lighter toasting requirements.

- Turn the thermostat adjustment knob clockwise for darker toasting. Turn the thermostat adjustment knob counter clockwise for lighter toasting. See figure 6.

IMPORTANT: Allow 15 minutes for toaster to stabilize after adjusting the thermostat.

Factory Thermostat Settings:

The 197 Series Toaster thermostat is set at # 7.
The 297 Series Toaster thermostat is set at # 9.

Conveyor and Motor Gears:

The top of the conveyor housing must be even with the tops of the end housings. There must be a 1/64" clearance between the conveyor and motor gear when aligned properly.

- To raise the conveyor housing, turn adjustment screws clockwise using a 3/32 Allen wrench. The adjustment screws are located on the bottom of both sides of the conveyor guide. To lower conveyor housing, turn adjustment screws counter clockwise. See figures 7 and 8.

figure 7

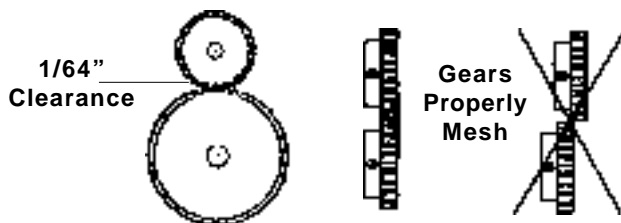
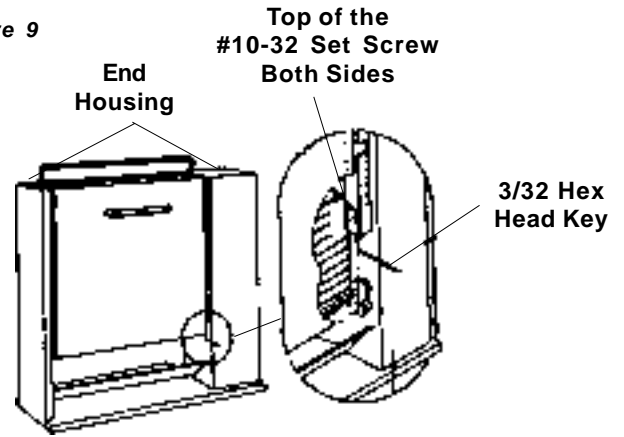

figure 9



CLEANING



CAUTION: This is not jet-water approved, and should not be cleaned with a water hose or jet spray.



CAUTION: Do not immerse in water.

1. Turn off both the heater and motor switches and unplug the toaster.
2. Allow platen to cool for 60 minutes before cleaning.
3. Remove the conveyor assembly.
4. Wipe the conveyor with a damp cloth. For the chain use a soft bristle brush.
5. Remove the release sheet and lay it on a flat surface. Thoroughly clean both sides with a damp cloth making sure all carbon build up is removed. Allow to air dry.

IMPORTANT: Rotate two sheets daily for longer life. Sheets last 4-6 months based on care and volume of product toasted.

6. Use a damp cloth to remove any carbon build up on the platen surface.

IMPORTANT: Do not use sharp objects, scotch brite pads, scouring pads, or abrasive cleaners on the platen, or teflon release sheets as it will cause irreparable damage.

PREVENTIVE MAINTENANCE (MOTOR)

To extend the life of your replacement motor, have an authorized factory service technician add 2-3 drops of 3 in 1 oil on a monthly basis.

Note: See the drawing for oil wick hole location.

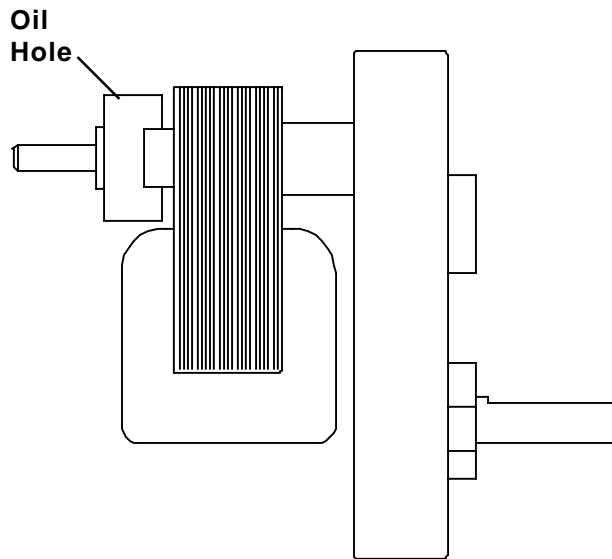

TROUBLE SHOOTING

PROBLEM	CAUSE	SOLUTION
Unit will not heat up. Power rocker switch light off.	No power to unit. Inoperable power cord. Loose connection on power switch. Inoperable power switch.	Ensure power cord is connected to proper Receptacle and the power inlet. Replace power cord. Tighten power switch connections. Replace power switch.
Unit will not heat up. Power rocker switch light on.	Inoperable thermostat. Inoperable platen.	Replace thermostat. Replace platen.
Unit heats up, but the conveyor does not run.	Loose motor switch connection. Inoperable motor. Stripped drive gear. Loose chain sprockets Gears not meshing. Inoperable motor switch.	Tighten motor switch connection. Replace motor. Replace drive gear. Adjust and tighten sprockets. Adjust conveyor set screws (See Conveyor Adjustments on page 3). Replace switch.
Unit under and over heats (does not respond to thermostat adjustments).	Inoperable thermostat.	Replace thermostat.
Buns under or over done.	Check platen adjustment. (See Platen Adjustments on page 3).	Adjust platen for proper compression
	Check platen temperature. (See Thermostat Adjustment on page 3).	Adjust thermostat for proper temperature.

FRONT VIEW

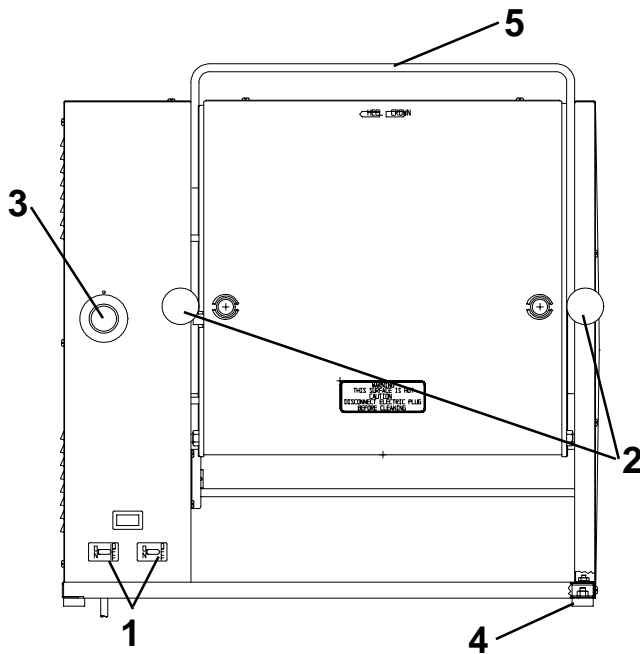

PARTS LIST

ITEM	PART NUMBER	DESCRIPTION
1	78-184S	Power and Motor Lighted Rocker Switch
2	197-185S	Platen Adjustment Knob (Pkg of 2)
3	70-012	Thermostat Knob
4	197-232	Foot
5	197-124	Conveyor Guide

CONVEYOR ASSEMBLY

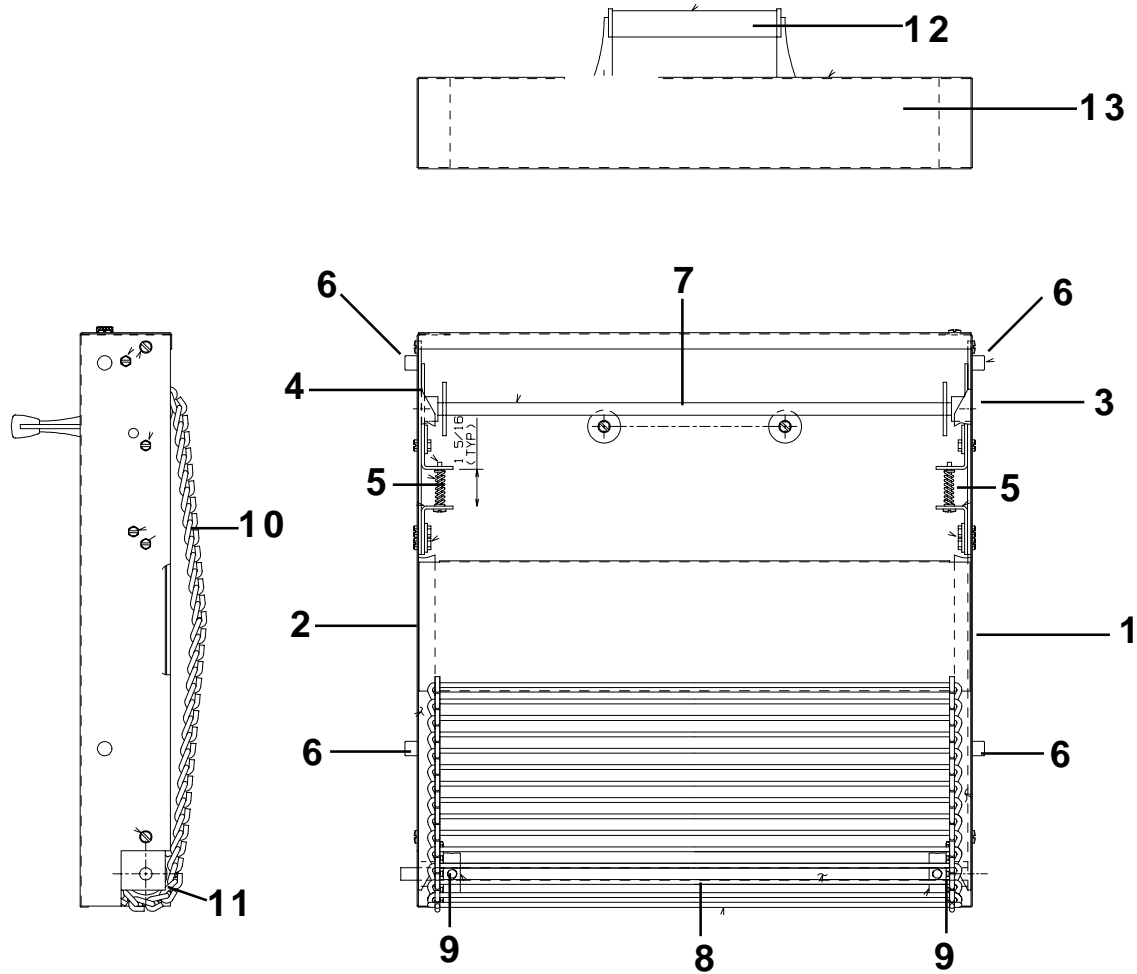

PARTS LIST

ITEM	PART NUMBER	DESCRIPTION
1	197-461	Right Side Shaft Carrier Assy.
2	197-463	Left Side Shaft Carrier Assy.
3	197-459	Right Side Shaft Carrier Adjustment Assy.
4	197-457	Left Side Shaft Carrier Adjustment Assy.
5	81-015	Compression Spring
6	197-467	Conveyor Slide
7	197-280	Shaft Assy.
8	197-465	Driven Shaft
9	197-302	Sprocket Kit (Pkg of 2)
10	89-684	Complete Chain Assy.
11	89-590	Single Conveyor Chain Link
12	197-7S	Black Handle With Screw
13	197-455S	Complete Conveyor Assy.

REAR VIEW

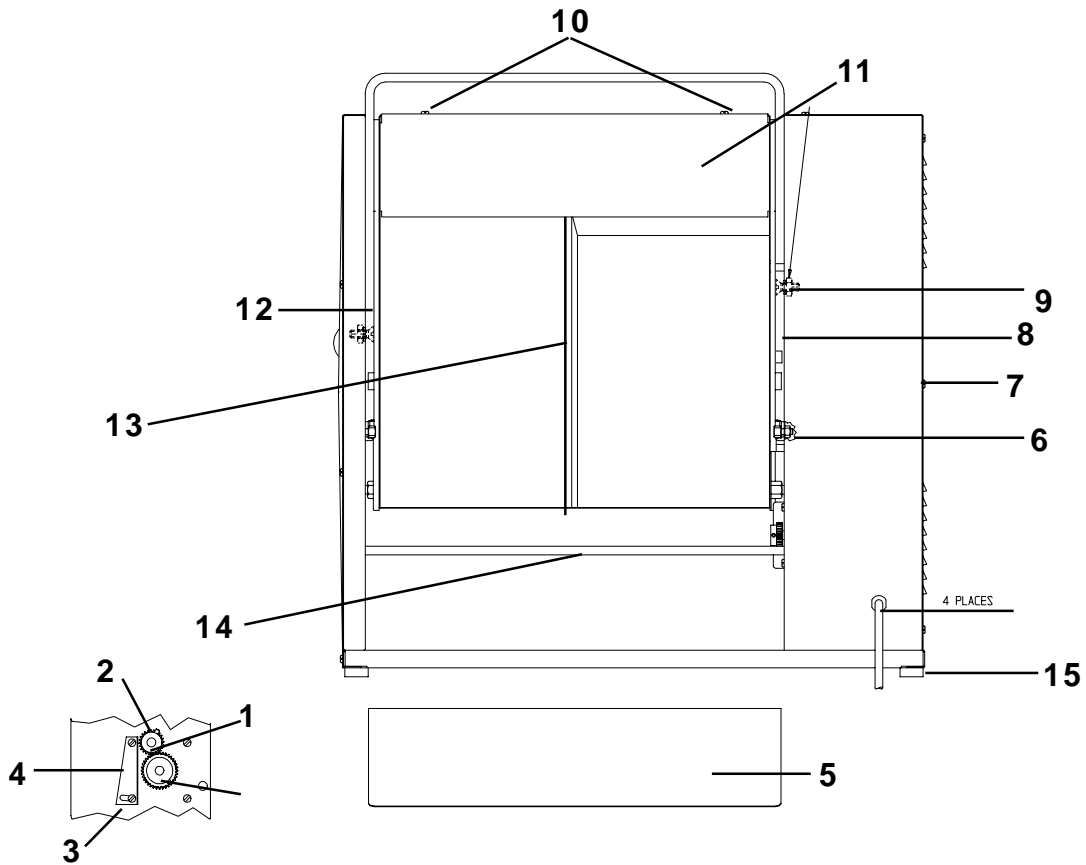

PARTS LIST

ITEM	PART NUMBER	DESCRIPTION
1	197-436S	Gear Kit
2	197-279	Pin
3	76-225	Slotted Pan Head Screw
4	197-131	Guard
5	197-33	Crumb Tray
6	73-007	Hex Nut
	197-16	Conveyor Stop
	76-165	Set Screw
7	76-640	Screw
8	197-96	Left Side Bun Fence
9	73-008	Self Locking Hex Nut
	73-030	Hex Nut
	79-016	Flat Washer
	76-033	Slotted Flat Head Screw
10	76-640	Screw
11	197-13	Lead Pan Weldment
12	197-97	Right Bun Fence
13	196-231	Platen
14	197-95	Tray Support
15	197-438CES	Line Cord (CE Version)
	197-438GBS	Line Cord (GB Version)

INTERNAL COMPONENTS

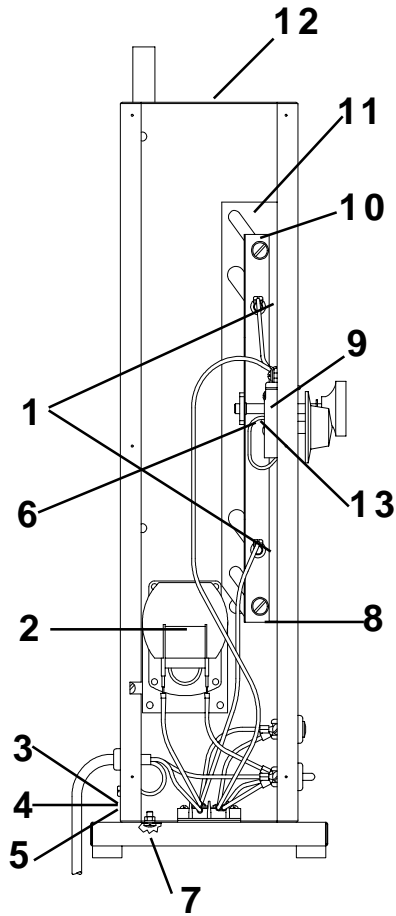

PARTS LIST

ITEM	PART NUMBER	DESCRIPTION
1	76-300	Slotted Pan Head Screw
2	87-028S	Motor
3	73-031	Hex Nut
4	79-033	Washer
5	76-051	Slotted Binder Head Screw
6	79-055	Flat Washer
7	76-040	Slotted Binder Head Screw
	79-017	Split Lock Washer
	73-030	Hex Nut
8	76-150	Slotted Pan Head Screw
	79-094	Flat Washer
9	79-016	Flat Washer
	76-095	Slotted Binder Head Screw
10	197-90	L. H. Side Plate Weldement W/ Adjustment Screw
	197-89	R.H. Slide Plate Bracket W/Adjustment Screw
11	197-87	Baffle
12	197-371	Housing
13	197-140	Thermostat With Knob

WIRING DIAGRAM

