

OPERATING INSTRUCTIONS

Slim-Line Horizontal Contact Toaster 296 & 297 Series



Prince Castle's 296H Series Slim-Line Bun Toaster provides perfect contact toasting. With adjustable bun thickness controls and an adjustable thermostat, the model 296H toasts up to 1400 buns per hour.

PRODUCT SPECIFICATIONS

Electrical:

Volts	Hz	Watts	KW	Amps
115	60	1500	1.5	12.5
220	50/60	1700	1.7	7.73

TABLE OF CONTENTS

PAGE

Installation	2
Operation	2
Adjustments	2
Cleaning	3
Parts List & Explode View	4-6
Troubleshooting & Wiring Diagram	7

LIMITED WARRANTY

This product is warranted to be free from defects in material and/or workmanship for a period of two (2) years from date of original installation, not to exceed 30 months from date of shipment from our factory. Any part or component which proves to be faulty in material and/or workmanship within the warranty period will be replaced or repaired (at the option of Prince Castle, Inc.) without cost to the customer for parts or labor.

This warranty is subject to the following exceptions/conditions:

- Service must be performed by an authorized Prince Castle Service Center.
- Any use of non-genuine Prince Castle spare parts voids this warranty.
- On site service is covered for one year from date of installation.
- All labor shall be performed during regular working hours. Overtime premium will not be covered.
- Damage caused by carelessness, neglect, and/or abuse (e.g., using wrong current, dropping, tampering with or altering electrical components, or improper cleaning) is not covered by the terms of this warranty. Equipment damaged in shipment, by fire, flood or an act of God is not covered.
- Normal adjustments as outlined in this manual are not covered under warranty.

INSTALLATION

1. After you have removed the toaster from the carton, inspect the unit for signs of damage. If there is damage to the unit:
 - Notify carrier within 24 hours after delivery.
 - Save carton and packing material for inspection purposes.
 - Contact your Prince Castle Dealer for replacement or the the Prince Castle Customer Sales Department at 1-630-462-8800, if purchased directly.
2. Verify that all parts have been received.
 - Horizontal Toaster and conveyor assembly.
 - Release Sheets—located in a 14" box.
 - Return Chute
3. Place toaster on flat surface. Remove protective coating.
4. Remove conveyor from guide rails, pulling the two plungers and sliding the conveyor forward. Remove all packing materials (nylon tape, foam block and black rubber packaging spacers) from conveyor and conveyor guides.
5. Re-insert conveyor, making sure the plunger pins butt up against the rear of the conveyor bracket cut outs. Loosen the two screws on the plunger bracket if bracket needs to be adjusted.

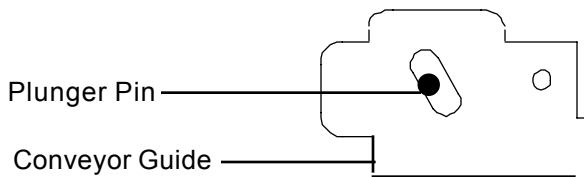

6. Feed the Teflon sheet through the toasting chamber, leaving enough sheet to fold over the top. Snap Teflon sheet holder into position.



7. Install return chute by placing the tabs into the slots at the rear of the toaster.
8. Plug unit into a grounded receptacle.

OPERATION

1. Turn the heater switch to the "on" position, the orange indicator light will illuminate. Allow 30 minutes for the platen to reach operating temperature.

2. Place a sample run of product into the front of the toasting chamber, the side to be toasted is facing up.
3. The toasted product should appear . Inspect for quality and make any adjustments as necessary.

ADJUSTMENTS

Bun Compression:

The toaster platen can be adjusted to provide the necessary compression needed on various products.

- Turn the two platen adjustment knobs on the bottom of the toaster clockwise to compensate for use on thicker bread products. Turn the two platen adjustment knobs counter clockwise for thinner products. The compression indicators on the front will show "1" for the thinnest products, "4" for the thickest.

Platen Temperature:

The temperature of the platen can be adjusted to compensate for darker or lighter toasting requirements.

- Turn the thermostat adjustment knob clockwise for darker toasting. Turn the thermostat adjustment knob counter clockwise for lighter toasting. See figure 6.

IMPORTANT: Allow 15 minutes for toaster to stabilize after adjusting the thermostat.

Conveyor and Motor Gears:

The correct motor and conveyor gear ratio will be set at the factory. Adjustments may be necessary due to shipment shocks or when replacing either gear or the motor. To adjust, place toaster on its back, loosen both set screws at the rear of the conveyor guides until they do not touch the conveyor slides. Retighten the left side screw until it touches the conveyor slide. Retighten the right side screw until it touches the conveyor slide then tighten an additional 1/3 turn. Put locktite in the set screws to hold them in place.

CLEANING



CAUTION: This is not jet-water approved, and should not be cleaned with a water hose or jet spray.



CAUTION: Do not immerse in water.

Daily: Teflon sheets, conveyor chain and housing

Monthly: Platen

1. Turn off both the heater and motor switches and unplug the toaster.
2. Allow platen to cool for 60 minutes before cleaning.
3. Remove the conveyor assembly by pulling plungers inward and pulling conveyor out.

4. Lay the conveyor on a flat surface with the chain facing up. Rotate chain until open link is showing. Pull up on the chain until the locking pins can be engaged. Push in both locking pins. This will allow the chain to be removed at the open link.

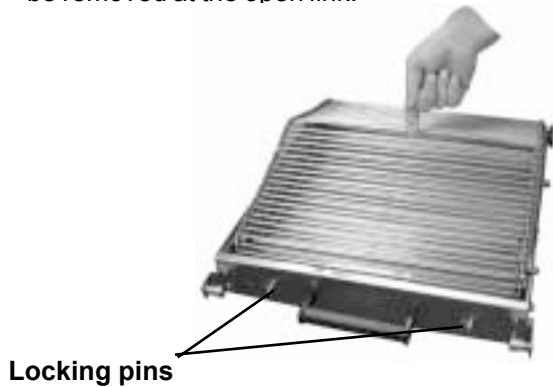

5. Wipe the conveyor with a damp cloth. For the chain, use a soft bristle brush and soap water.
- 6.. Remove the release sheet and lay it on a flat surface. Thoroughly clean both sides with a damp cloth making sure all carbon build up is removed. Allow to air dry.

IMPORTANT: Rotate two sheets daily for longer life. Sheets last 4-6 months based on care and volume of product toasted.

7. Use a damp cloth to remove any carbon build up on the platen surface.

IMPORTANT: Do not use sharp objects, scotch brite pads, scouring pads, or abrasive cleaners on the platen, or teflon release sheets as it will cause irreparable damage.

PREVENTIVE MAINTENANCE (MOTOR)

To extend the life of your motor, have a factory authorized service technician add 2-3 drops of 3 in 1 oil on a monthly basis.

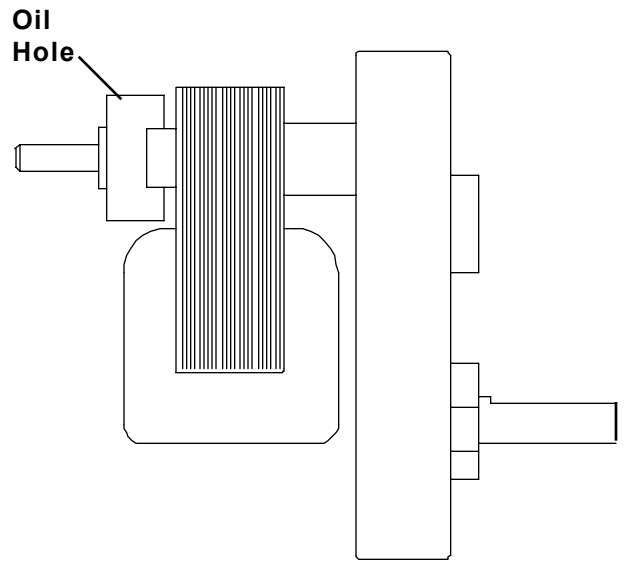

Exploded View

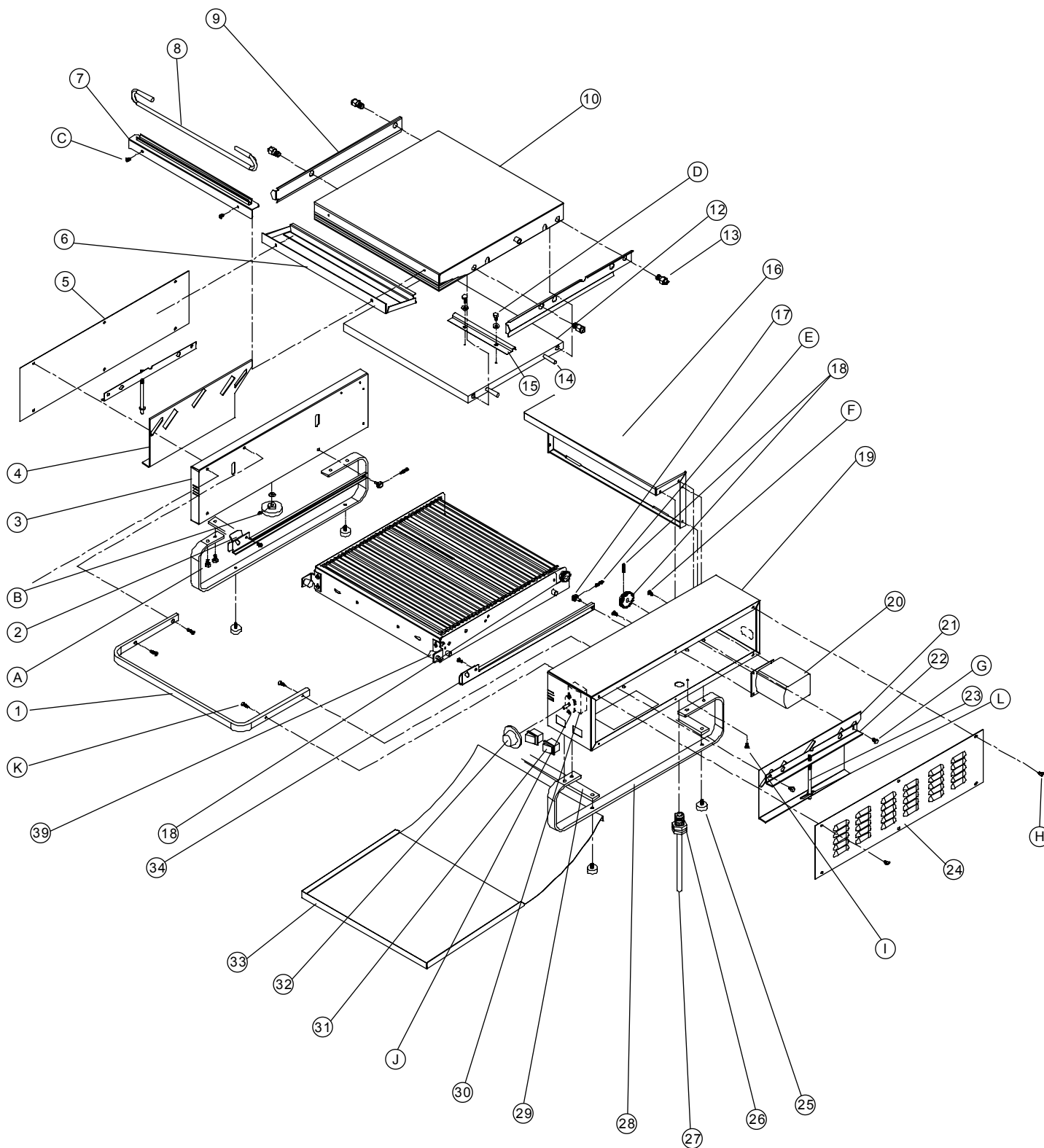

PARTS LIST

ITEM	PART NUMBER	DESCRIPTION
1	297-042	Upper Support
2	297-066	Left Conveyor Guide
3	297-043	Left Upright
4	297-054	Left Side Bracket
5	297-020	Left Upright Cover
6	197-13	Lead Pan
7	297-079	Release Sheet Bracket
8	297-080	Release Sheet Clamping Bar
9	297-059	Left Bun Fence
10	197-401	Heater Housing
11	297-058	Right Bun Fence
12	196-023S	Platen (196,296)
	197-430S	Platen (197,297)
	197-431S	Platen 220V (297)
13	197-41	Shoulder Spacer
14	197-424	Platen Insulator
15	197-29	Retainer
16	297-014	Rear Brace
17	197-16	Conveyor Stop
	73-007	Hex Nit
18	197-436S	Gear Kit
19	297-043	Motor Upright
20	87-026S	Motor with Bracket
	87-028S	Motor 220V
21	297-053	Right Side Bracket
22	297-056	Platen Adjustment Bracket
23	297-052	Platen Adjustment Shaft
24	297-018	Motor Upright Cover
25	197-232	Foot
26	66-045	Strain Relief
27	197-438S	Power Cord (Kit#)
28	297-038	Leg
29	297-044	Cross Brace
30	297-010S	Thermostat with Knob
31	78-184S	Power Switch
32	70-012	Thermosat Knob only
33	297-045	Return Chute
34	297-065	Right Conveyor Guide
35	297-052	Platen Adjustment Shaft
36	297-073	Conveyor Bracket
37	86-241	Spring Loaded Plunger
38	197-1855	Adjustment Knobs (Package of 2)
39	297-073S	Conveyor Bracket with Plunger
	86-241	Plunger
A	76-051	Screw
	79-033	Washer
B	76-095	Screw
	79-016	Washer
C	76-640	Screw
D	76-178	Screw
	79-039	Washer
E	76-165	Screw
F	76-225	Screw
G	76-150	Screw
	79-094	Washer
H	76-640	Screw
I	73-031	Nut
	76-051	Screw
J	76-095	Screw
	79-016	Washer
K	76-600	Screw
	73-030	Nut
L	79-055	Washer

CONVEYOR ASSEMBLY

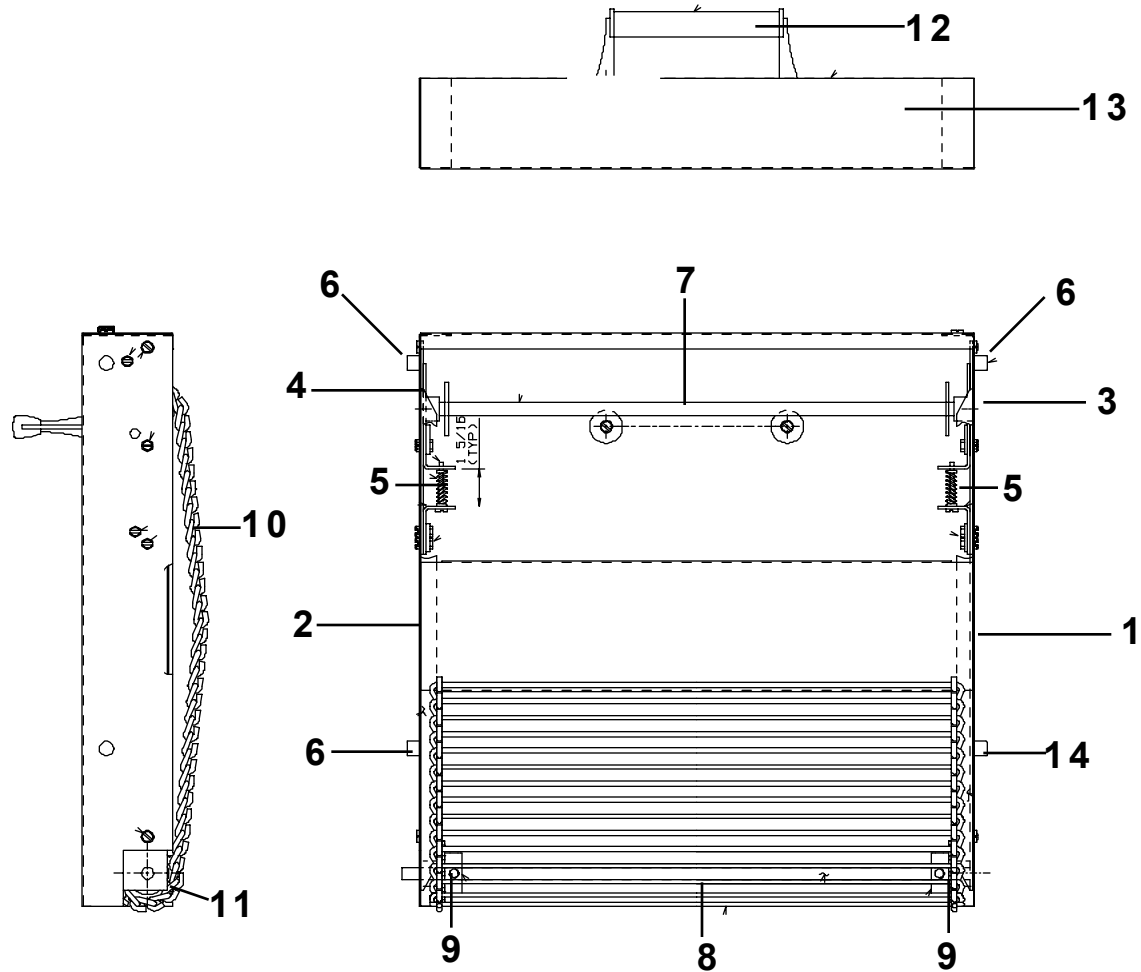

PARTS LIST

ITEM	PART NUMBER	DESCRIPTION
1	297-068	Right Side Shaft Carrier Assy.
2	297-067	Left Side Shaft Carrier Assy.
3	297-069	Right Side Carrier W/Detent
4	297-070	Left Side Carrier W/Detent.
5	81-015	Compression Spring
6	197-94	Left Hand Conveyor Slide
7	197-280	Shaft Assy.
8	197-37	Driven Shaft
9	197-302	Sprocket Kit (Pkg of 2)
10	297-084	Complete Chain Assy.
11	89-590	Single Conveyor Chain Link
12	197-7S	Black Handle With Screw
13	297-064S	Complete Conveyor Assy.
14	197-386	Right Hand Conveyor Slide

TROUBLE SHOOTING

PROBLEM	CAUSE	SOLUTION
Unit will not heat up. Power rocker switch light off.	No power to unit. Inoperable power cord. Loose connection on power switch. Inoperable power switch.	Ensure power cord is connected to proper Receptacle and the power inlet. Replace power cord. Tighten power switch connections. Replace power switch.
Unit will not heat up. Power rocker switch light on.	Inoperable thermostat. Inoperable platen.	Replace thermostat. Replace platen.
Unit heats up, but the conveyor does not run.	Loose motor switch connection. Inoperable motor. Stripped drive gear. Loose chain sprockets Gears not meshing. Inoperable motor switch.	Tighten motor switch connection. Replace motor. Replace drive gear. Adjust and tighten sprockets. Adjust conveyor set screws (See Conveyor Adjustments on page 3). Replace switch.
Unit under and over heats (does not respond to thermostat adjustments).	Inoperable thermostat.	Replace thermostat.
Buns under or over done.	Check platen adjustment. (See Platen Adjustments on page 3).	Adjust platen for proper compression

WIRING DIAGRAM

