

# OPERATING INSTRUCTIONS



## Merlin II

### Slow Cook/Hold Timers

### Model No. 740-T44N & 740-T66N

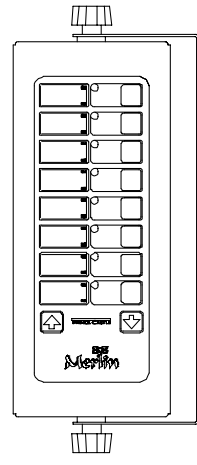

Model	Description
740-T44N	Four Channel
740-T66N	Six Channel

## ELECTRICAL

**740-T Series**  
120 Volts  
50-60 Hz

TABLE OF CONTENTS	PAGE
Installation .....	2
Programming .....	2
Operation .....	3
Cleaning .....	4
Parts List.....	4
Exploded View .....	5
Troubleshooting .....	5
Wiring Diagrams .....	6

### LIMITED WARRANTY

This product is warranted to be free from defects in material and/or workmanship for a period of 1 year from date of original installation, not to exceed 18 months from the date of manufacture.

Any component which proves to be faulty in material and/or workmanship will be replaced or repaired (at the option of Prince Castle, Inc.) without cost to the customer for parts and labor. This equipment is portable; charges for on-location service (e.g., trip charges, mileage) are not included in the provisions of this warranty.

This warranty is subject to the following exceptions/conditions:

- Use of any non-genuine Prince Castle parts voids this warranty.
- All labor to be performed during regular work hours. Overtime premium (the incremental amount) will be charged to the customer.
- Damage caused by carelessness, neglect and/or abuse (e.g., dropping, tampering or altering parts, equipment damaged in shipment, by fire, flood or an act of God) is not covered under this warranty.
- All problems due to operation at voltages other than that specified on equipment nameplates are not covered by this warranty. Conversion to correct voltage is the customer's responsibility.
- This equipment must be serviced by Prince Castle Authorized Service Agency or a Prince Castle Service Technician during the warranty period.

## INSTALLATION

- After you have removed the timer from the carton, inspect the unit for signs of damage. If there is damage to the unit:
  - Notify carrier within 24 hours after delivery.
  - Save carton and packing materials for inspection purposes.
  - Contact your local dealer or, if purchased directly, the Prince Castle Customer Sales Department at 1-800-722-7853 to arrange for a replacement to be sent.
- Verify that all parts have been received. Mounting Brackets and hardware provided.
- To mount the timer, place mounting brackets in desired location. Scribe location of mounting holes, center punch, and drill holes. Attach timer to mounting brackets placing star washer between bracket and timer.

**PRINCE CASTLE Logo** Activates Program Mode and used to adjust the alarm sound level.

The timer currently supports 3 program stages or functions. Each program stage is independently programmed. The stages run in succession beginning with stage #1 and ending with stage #3. After each stage, the timer sounds an alarm and flashes "End". Each stage has a time and LED color. The factory-default times, stage color, and alarm modes are described in Table 2.

**Note:** Some stage modes are not available (N/A) for all stages and the alarm beat and pitch is not programmable.

Below Are The Pre-Set Stages Per Nathan's specifications

Stage	Time	Color	Alarm Pitch	Alarm Beat
1	3:00	Green	Low	Slow
2	0	Yellow	High	Slow
3	3:00	Red	High	Fast

## DISPLAYS AND INDICATORS

**TIME Display** Shows the time for the selected channel number.

**H:M** Indicates the time value is in **H**ours and **M**inutes.

**M:S** Indicates that the time value is in **M**inutes and **S**econds.

**LED Indicators** Located above each channel timer button, these lights change color depending on the stage of the countdown. Green = Stage 1, Yellow = Stage 2 Red = Stage 3.

## CONTROLS

**Channel (Button)** Activates countdown sequence in the run mode.



**SCAN/UP ARROW**

In the program mode, it increases time values for each channel. In the Run Mode, it is used in conjunction with logo button to increase the volume.



**SCAN/DOWN ARROW**

In the program mode, it decreases time values for each channel. In the run mode, it is used in conjunction with logo button to decrease the volume.

## PROGRAMMING

- Press and hold the **PRINCE CASTLE** logo for six seconds. The **TIME** displays will change from "----" to "**Prog**" and a beep will sound.

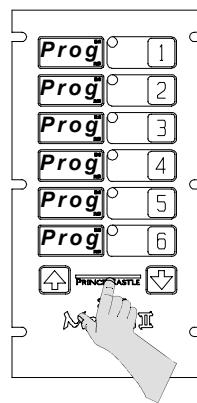

**IMPORTANT:** If a channel is not pressed within 30 seconds the display will change back to "-- : --" and the timer will automatically go back to the run mode.

**NOTE:** While all displays are showing "**Prog**", pressing the **UP** or **DOWN ARROW** Button will increase or decrease, respectively, the display intensity level.

- Press the channel button for the particular timer channel you wish to program. The time window for the selected channel will show the current time for stage #1 and the LED indicator will change to green. This is the stage #1 program mode.

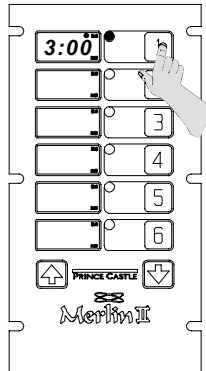

- Press the **SCAN/UP Arrow** or the **SCAN/DOWN Arrow** button to change the program time for the selected channel.

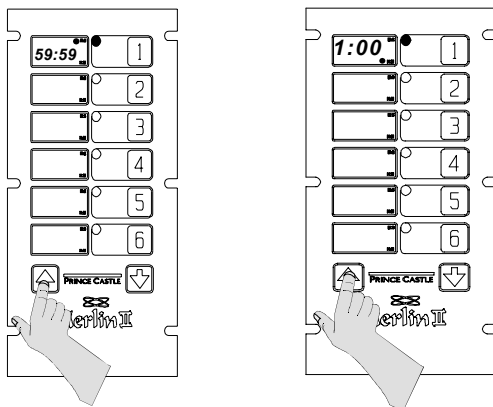

**IMPORTANT:** To change from Minutes and Seconds **M:S** to Hours and Minutes **H:M**. Press and hold the **SCAN/UP** Button. When the display reaches 59:59 it will automatically change to 1:00 Hour and the LED will switch from M:S to H:M. The program value for the **H:M** indicator is from 1:00 hour to 17 hours: 59 minutes.

- Press the selected channel button again. The time will show the current time for stage #2 and the LED indicator will change to yellow. This is the stage #2 program mode. Change the time using the **UP** and **DOWN ARROW** Buttons.
- Press the selected channel button again. The time window will show the current time for stage #3 and the LED indicator will change to red. This is the stage #3 program mode. Change the time using **UP** and **DOWN ARROW** Buttons.

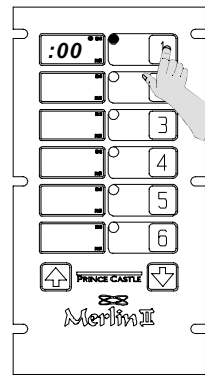

**STAGE 2**

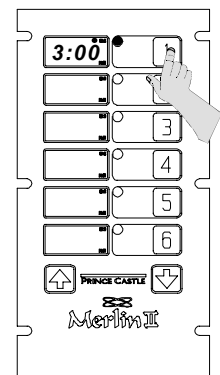

**STAGE 3**

- You may back up to a particular stage by pressing the channel button until the LED indicator cycles through stage #3 (red) and rolls-over to stage #1 (green). Continue pressing the channel button until the desired program stage mode is selected.
- When finished programming each desired channel, momentarily press the **PRINCE CASTLE** logo to end the Program Mode. This saves the program changes you have made for all channels.
- You can change the sound level of the alarm in **RUN MODE**. Press and hold the **PRINCE CASTLE** logo; then, within six seconds, press either the **SCAN UP** Arrow button or the **SCAN DOWN** Arrow button. The **SCAN UP** Arrow button adjusts the sound level to the louder alarm, the **SCAN DOWN** Arrow button adjusts the sound level to the lower alarm.

## OPERATION

- To activate a programmed channel, press the corresponding channel number. The LED indicator associated with the timer channel will light up and the color will be determined by the first active (non-zero) stage (typically green). The time window will start to countdown. When the time reaches the end of the first stage (typically equal to the stage #1 time) the display will flash "End" and an alarm will sound. To cancel the alarm, press the timer channel button. The LED color will change to the next active stage LED color (typically red). The time window will start to countdown. When the time reaches the end of the stage (typically equal to the stage #3 time) the display will flash "End" and an alarm will sound. To cancel the alarm, press the timer channel button.

**Important:** To cancel a channel after it is activated, press the channel number three times quickly. This will cancel the countdown sequence.

**Important:** Do not use any utensils (spatula, tongs, etc.) to start or stop the timing cycle. This will damage the overlay and switch panel. It also voids the warranty.

---

## CLEANING

1. Do not allow grease to build up on the timer, wipe it down daily with clean damp cloth.

**IMPORTANT:** Do not use abrasive or chemical cleaners on your timer, this may cause damage to the overlay.

---

## PART LIST

ITEM	PART NUMBER	DESCRIPTION
1	69-079S	Plastic Rivet (Pkg. Of 2)
2	740-034	Rear Cover
3	740-237S 740-238S	Main P.C. Board (T44N) Main P.C. Board (T66N)
5	88-653-2-4S	Speaker Assy.
6	541-135	Speaker Shim
7	740-027S 740-028S	Switch Panel Assy. (T66N) Switch Panel Assy. (T44N)
8	740-036	Front Cover
9	70-048S	Knob W/Hardware
10	72-292S	Power Supply (110 Volt)

## EXPLODED VIEW

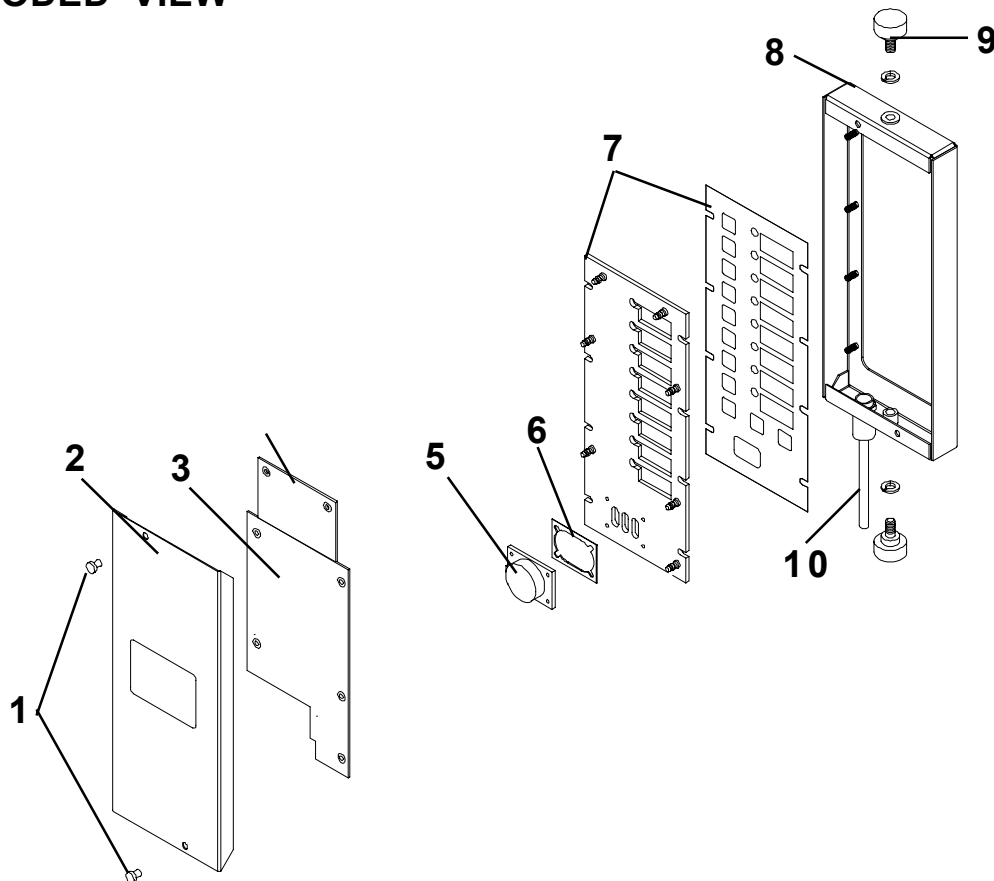

## TROUBLESHOOTING GUIDE

PROBLEM	CAUSE	SOLUTION
A. No displays or indicators lit.	Unit unplugged. Store's circuit breaker blown. Defective transformer. Circuit inoperable.	Plug unit in. Reset breaker. Replace Main Circuit Board. Replace Main Circuit Board.
B. Absence of Audio Alarm.	Speaker inoperable. Circuit inoperable.	Replace Speaker. Replace Main Circuit Board.
C. Unit will not enter program mode. Display does not show <b>"Prog"</b> .	All channels are still counting. Logo Switch inoperable.	Wait until channels are in stop mode. Replace Switch Panel.
D. Unit enters program mode. Display shows <b>"Prog"</b> , but cannot change times.	The channel is still counting. Arrow Switch inoperable. Circuit inoperable.	Wait until channel is in stop mode. Replace Switch Panel. Replace Main Circuit Board.
E. Unable to start, stop, or store timer presets in program mode. Missing or abnormal characters in displays.	Circuit inoperable.	Replace Switch Panel. If problem persists, replace Main Circuit Board.

# WIRING DIAGRAM 740-T44,T66 & T88

