

# OPERATING INSTRUCTIONS

## Wedge Witch® Model No. 908-A



Save natural juices and flavor by cleanly sectioning fruits and vegetables with Prince Castle's Wedge Witch®. Simply place your lemons, limes or other fruits and vegetables into the Wedge Witch®, and with one firm, quick stroke, the Wedge Witch® instantly delivers perfect wedges every time. The solid, cast-aluminum construction and nonskid rubber feet provide stability and long-lasting performance. The safety head prevents misalignment, blade damage, and protects the hands of the operator. Select any of the easy-to-clean four, six, eight, ten or twelve section models.

### TABLE OF CONTENTS

### PAGE

Installation .....	2
Operating .....	2
Cleaning .....	3
Maintenance/Replacing Blades .....	3
Parts List .....	3

### LIMITED WARRANTY

This product is warranted to be free from defects in workmanship for a period of 1 year from date of original installation, not to exceed 18 months from the date of manufacture with the exception of the blade cartridge/ blades. Blades cartridge/ blades are warranted to be free from defects at time of delivery only. Any component which proves to be faulty during the warranty period will be replaced without cost to the customer for parts only.

This warranty is subject to the following conditions:

- This unit is considered carry in; charges for on-location service (e.g., trip charges, mileage and labor) are not included under the provisions of this warranty.
- Damage caused by carelessness, neglect, and/or abuse (e.g., dropping, tampering with or altering parts) voids this warranty.
- Blades are warranted to be free from defects in material and/or workmanship at the time of delivery only.

### PRODUCT SPECIFICATIONS

#### 908-A Series

	Dimensions
Width	10" (25.4 cm)
Depth	9" (22.9 cm)
Height	21" (53.3 cm)
Shipping Weight	6 lbs. (2.7 kg.)

#### Model No.

#### No. of Wedges

908-A4	4
908-A6	6
908-A8	8
908-A10	10
908-A12	12

PRINCE CASTLE INC.  WORLDWIDE

355 East Kehoe Blvd. • Carol Stream, IL 60188

Tel: (630) 462-8800 • Fax: (630) 462-1460

Toll Free: 1-800-PCASTLE

---

## INSTALLATION

1. After you have removed the Wedge Witch® from the carton, inspect the unit for signs of damage. If there is damage to the unit:
  - Notify carrier within 24 hours after delivery.
  - Save carton and packing materials for inspection purposes.
  - Contact the Prince Castle Customer Sales Department at 1-630-462-8800 to arrange for a replacement to be sent.
2. Verify that all parts have been received.



**CAUTION: Blades are extremely sharp.**

3. Wash and core tomatoes with Prince Castle Model No. 953 Tomato Core-It®. See figure 1.

*figure 1*



4. To keep lemons and limes from hanging up in the blades cut off ends. See figure 2.

*figure 2*



5. To obtain smaller sections, slice product in half before wedging. See figure 3.

*figure 3*



6. Place Wedge Witch® on a clean sanitized prep table (a sink area should not be used).
7. Lubricate guide rods before wedging the first product of the day.
8. Ensure blade assembly is securely in place and thumbscrews holding the blade assembly in place are tight.

---

## OPERATION

1. Grasp handle and pull all the way to the end of the guide rods.
2. Center product to be wedged on centering pin located on blade assembly. See figure 4.

*figure 4*



**CAUTION: Blades are extremely sharp. Handle with care.**

3. Push handle down with a quick firm stroke until the pusher head stops. The product should be completely wedged. See figure 5.

*figure 5*



## PREVENTATIVE MAINTENANCE

1. Lubricate guide rods daily, before use.
2. Be sure to tighten the thumbscrews (Item 2 on exploded view) on the blade assembly daily.

## REPLACING BLADES

1. Loosen (2) thumbscrews holding blade assembly to blade frame plate.
2. Remove old blade assembly carefully. Do not remove blade frame plate.

**CAUTION:** Blades are very sharp. Handle with care.

3. Install new blade assembly in blade frame plate and tighten down with the (2) thumbscrews.

## CLEANING

**CAUTION:** Blades are very sharp. Handle with care.

1. Spray blade assembly and pusher head with hot water to remove residue.
2. Brush the blade assembly and pusher head with a brush and hot soapy water (order Prince Castle Model No. 912-107 Cleaning Brush).
3. Rinse by spraying with hot water.

## EXPLODED VIEW

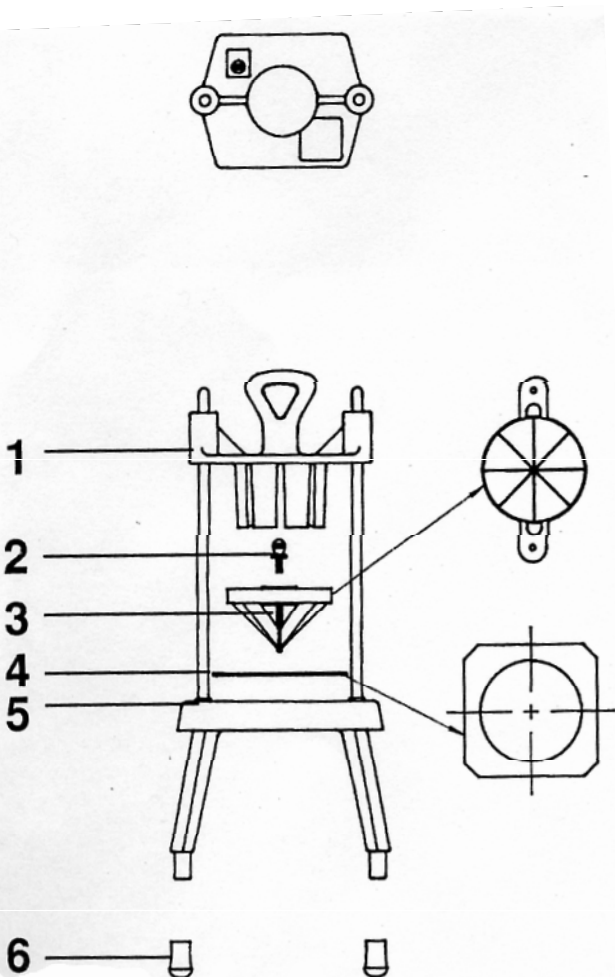

## PARTS LIST

ITEM	PART NO.	DESCRIPTION
1	908-75S 908-76S 908-77S	Pusher Head 4 & 8 Section Pusher Head 10 Section Pusher Head 6 & 12 Section
2	76-582S	Thumbscrew (Package of 2)
3	908-69 908-70 908-71 908-72 908-73	Blade Assy 4 Section Blade Assy 6 Section Blade Assy 8 Section Blade Assy 10 Section Blade Assy 12 Section
4	908-79	Mounting Plate
5	910-8	Guide Rod Cushions (Package of 2)
6	89-959S	Rubber Feet (Package of 4)