

OPERATING INSTRUCTIONS

Onion Witch® Model No. 911 Series

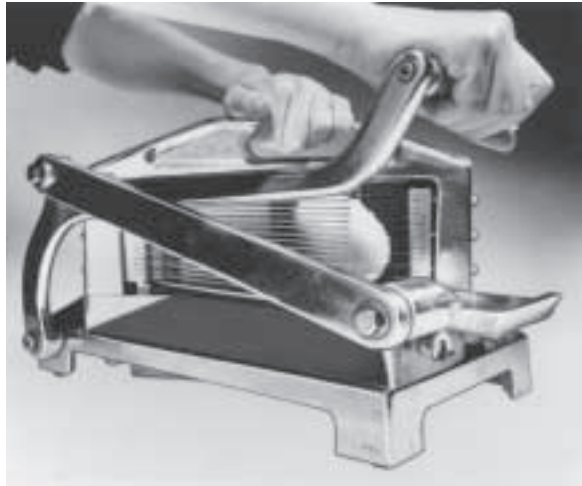

Speed and quality construction make the Prince Castle Onion Witch® a "must have" slicer for any food service operation. This commercial-quality slicer is perfect for onions and all hard vegetables and requires no pre-scoring. Superior leverage provides fast, effortless operation and optimum performance. Slice all the onion or vegetables you need in just minutes. This slicer is available in three different thicknesses: $\frac{3}{16}$ " (.48 cm), $\frac{1}{4}$ " (.64 cm) or $\frac{3}{8}$ " (.95 cm).

PRODUCT SPECIFICATIONS

911 Series	Dimensions	Model No.	Slice Thickness
Length	19" (48.3 cm)	911-A	$\frac{3}{16}$ " (0.48 cm)
Width	11" (27.9 cm)	911-B	$\frac{1}{4}$ " (0.64 cm)
Height	10" (25.4 cm)	911-C	$\frac{3}{8}$ " (0.95 cm)
Shipping Weight	17lbs. (7.7 kg.)		

TABLE OF CONTENTS	PAGE
Installation	2
Operating	2
Preventive Maintenance/Cleaning	2
Replacing Blades	3
Parts List.....	4
Exploded View	4

LIMITED WARRANTY

This product is warranted to be free from defects in material and/or workmanship for a period of 1 year from date of original installation, not to exceed 18 months from the date of manufacture.

Any component which proves to be faulty in material and/or workmanship will be replaced or repaired (at the option of Prince Castle, Inc.) without cost to the customer for parts and labor. This equipment is portable; charges for on-location service (e.g., trip charges, mileage) are not included in the provisions of this warranty.

This warranty is subject to the following exceptions/conditions:

- Use of any non-genuine Prince Castle parts voids this warranty.
- All labor to be performed during regular work hours. Overtime premium (the incremental amount) will be charged to the customer.
- Damage caused by carelessness, neglect and/or abuse (e.g., dropping, tampering or altering parts, equipment damaged in shipment, by fire, flood or an act of God) is not covered under this warranty.
- All problems due to operation at voltages other than that specified on equipment nameplates are not covered by this warranty. Conversion to correct voltage is the customer's responsibility.
- This equipment must be serviced by Prince Castle Authorized Service Agency or a Prince Castle Service Technician during the warranty period.

INSTALLATION

1. After you have removed the Onion Witch® from the carton, inspect the unit for signs of damage. If there is damage to the unit:
 - Notify carrier within 24 hours after delivery.
 - Save carton and packing materials for inspection purposes.
 - Contact the your Prince Castle Dealer or th Prince Castle Customer Sales Department at 1-800-722-7853 if ordered directly
2. Verify that all parts have been received.



CAUTION: Blades are extremely sharp.

OPERATION

Before slicing onions makes sure blades are tight, remove all dry skin, and cut off both ends. Refer to page 3 for proper tightening procedures.

1. This machine slices onions up to 3-3/4" (9.5 cm) in diameter.



CAUTION: Blades are extremely sharp. Handle with care. Make sure blades are tight prior to use.

2. Hold onion between thumb and fore finger. With onion slicer in loading position, place onion on carrier plate in pusher head recess. See figure 1.

figure 1

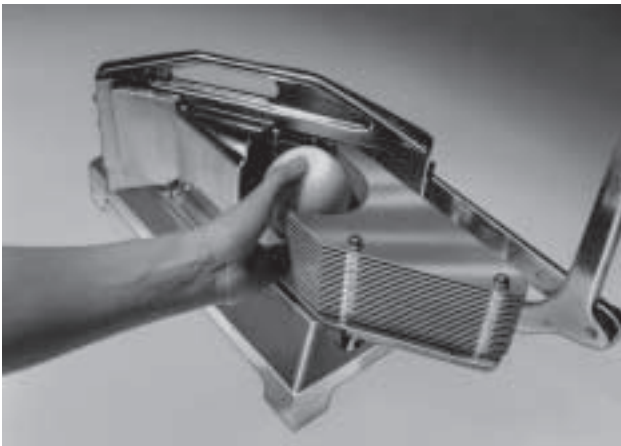

To assist in producing consistent slices and also to reduce blade damage do not force onions onto carrier plate. If onion touches blades at this point, slices will vary and blades will be damaged.

3. With left hand on bridge handle and right hand on pusher handle, push handle all the way over in a firm, quick continuous movement. Remove sliced onion from carrier plate before reversing pusher handle.

PREVENTATIVE MAINTENANCE

- | Lubricate guide rods with Petrogel or vegetable oil daily, before use.
- | After each washing, add vegetable oil to bearing studs. See exploded view for locations.
- | Check guide block retaining screws for tightness.
- | Bent, nicked, and dull blades must be replaced immediately. Always change complete sets of blades. Do not mix used blades with new blades.

CLEANING



CAUTION: Blades are very sharp. Handle with care. Always clean the machine immediately after use before juices dry on blades.

1. Spray blade assembly and pusher head with hot water to remove residue.
2. Brush the blade assembly and pusher head with a brush and hot soapy water.
3. Rinse by spraying with hot water.

REPLACING BLADES

911 Series Onion Witch DUAL BLADE SLICER

INSTALLATION

For proper installation the blade assembly with the lesser number of blades must be installed in front of the bridge casting. The blade assembly with the greater number of blades is located directly behind the blade assembly with the lesser number of blades. See figure 2.

1. Center both blade assemblies, as described above, in the bridge casting.
2. Loosely install all 12 socket-head screws, then slightly tighten the four center socket-head screws at both ends of the bridge casting.
3. With the blade assembly centered, tighten all 12 screws a little at a time so all screws are tightened the same amount.

IMPORTANT: Blades must be fully tightened for proper operation. Frequently check blades for tightness.

Before using the machine, check to see that blades are tight. Always check blades from the rear of the blade assembly. Use the small screwdriver or Allen wrench provided. Blades should produce a musical “ping” when strummed, indicating they are tight.



CAUTION: Loose blades will bow during use, causing the pusher head to damage blades.

figure 2

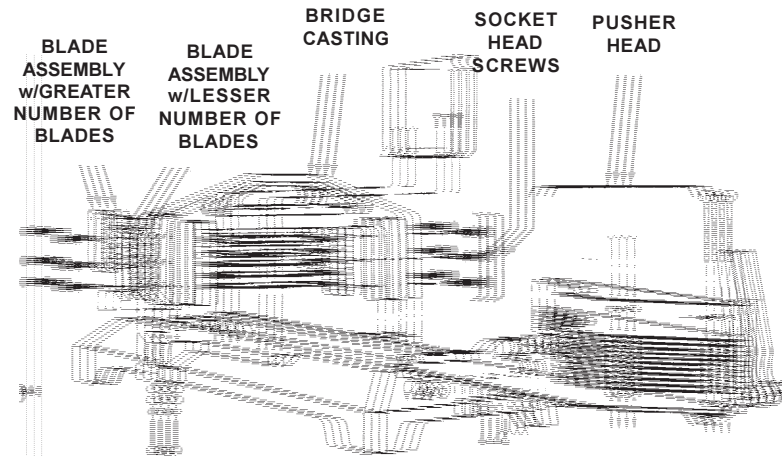

REPLACEMENT BLADES

Replacement blades are available from your local Prince Castle Service Center. Order by part number listed in Parts List.

EXPLODED VIEW

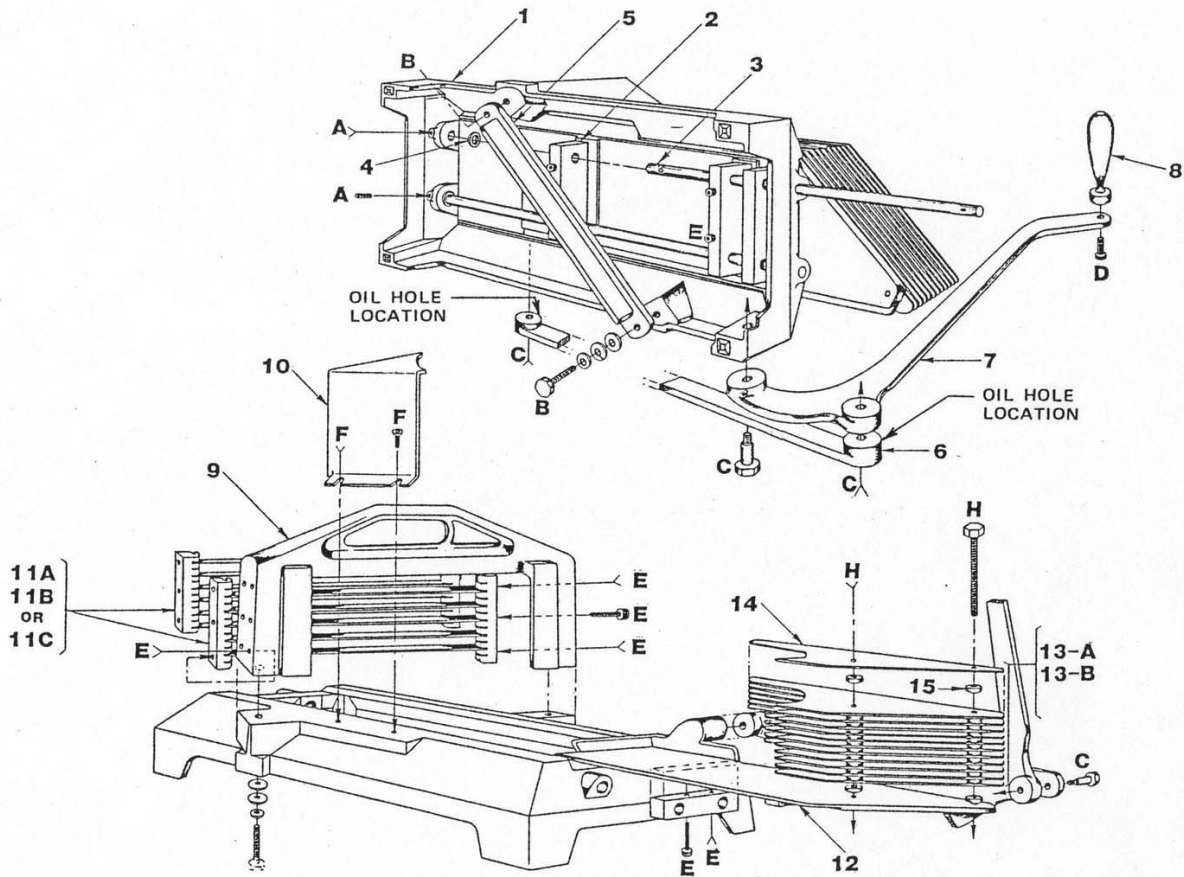

PARTS LIST

ITEM	PART NO.	DESCRIPTION	ITEM	PART NO.	DESCRIPTION
1	911-63	Base w/Feet	13-A	911-12	Pusher Head Assembly 3/16" & 3/8"
2	919-121S	Bearing Block w/Retaining Screws	13-B	911-13	Pusher Head Assembly 1/4"
3	919-14	Guide Rod w/2 Cushions & 2 Set Screws	14	911-18	Pusher Head Plate w/Spacers 1/4", 3/16" & 3/8"
4	919-17S	Cushion, Guide Rod	15	919-128S	Spacer 1/4" (Included w/Items 13-B & 14)
5	911-11	Lower Cross Brace		919-126S	Spacer 3/16" & 3/8" (Included w/Items 13-A & 14)
6	911-6	Pusher Bar	16	919-18	Foot (Pkg of 4)
7	911-7	Pusher Handle	A	76-492	Set Screw, Socket Head Cap Point 1/4-20 x 1/4" Long
8	919-114	Handle w/Retaining Screw	B	76-492	Bolt, Hex Head 3/8-16x3"
9	911-24	Bridge	79-027		Washer, Split Lock 3/8 Norm. I. D.
10	911-10	Safety Guard w/Retaining Screws	C	911-62	Bearing Stud
11-A	911-A1	Replacement Blade Assembly 3/16" for Dual Blade Set Units (Pkg of 2)	D	76-476	Screw, Socket Head Cap 1/4"-20 x 3/4" (Included w/Item 8)
11-B	911-B1	Replacement Blade Assembly 1/4" for Dual Blade Set Units (Pkg of 2)	E	911-15	Screw, Socket Head Cap 1/4"-20 x 1-1/4" Long (Pkg of 12)
11-C	911-C1	Replacement Blade Assembly 3/8" (Pkg of 1) (All 3/8" units are single blade set)	F	76-238	Screw, Phillips Head Cap 10-32 x 1/4" Long
12	911-58	Carrier Plate	H	919-19	Screw, Hex Head 1/4-20 x 3-1/4" (Included w/Item 13-A)
				76-534	Screw, Hex Head 1/4-20 x 3-1/2" (Included w/Item 13-B)