

OPERATING INSTRUCTIONS

Dunkin Donuts Holding Bin DHB-DDB



Prince Castle Food Holding Bins provide the capacity required for large foodservice operations while performing at peak energy efficiency. Each unit features two individually controlled holding chambers. New Reli-A-Temp™ infrared heater technology holds product temperatures more consistent within the designated holding time than other types of heating systems. This exclusive heater design spreads the heat evenly over the entire food holding area, eliminating edge drop off. Food is kept at the desired serving temperature.

ELECTRICAL SPECIFICATIONS

Voltage	120
Watts	1550
Hertz	50/60
Amps	12.9

TABLE OF CONTENTS

	PAGE
Installation	2
Controller Identification	2
Operation	3
Programming	3
Calibration & Cleaning	4
Troubleshooting Guide	5
Exploded View & Parts List	6
Wiring Diagram	8

LIMITED WARRANTY

This product is warranted to be free from defects in material and/or workmanship for a period of two (2) years from date of original installation not to exceed 30 months from date of shipment from our factory. P.C. Boards and Heaters are warranted for three (3) years from date of installation, not to exceed 42 months from date of shipment from our factory. This warranty covers on-location service (i.e., trip charges and/or mileage). Travel mileage is limited to 100 miles round trip (one trip per warranty) from an authorized service agency or its sub-service agency.

Any component which proves to be faulty in material and/or workmanship will be replaced or repaired (at the option of Prince Castle, Inc.) without cost to the customer for parts or labor.

This warranty is subject to the following exceptions/conditions:

- Any use of non-genuine Prince Castle spare parts voids this warranty.
- All labor shall be performed by an authorized Prince Castle Service Agent during regular working hours. Overtime premium will not be covered.
- Damage caused by carelessness, neglect, and/or abuse (e.g., dropping, tampering or altering parts), equipment damaged in shipment, by fire, flood or an act of God is not covered under this warranty.

INSTALLATION

1. After you have removed the bin from the carton, inspect the unit for signs of damage. If there is damage to the unit:
 - Notify carrier within 24 hours after delivery.
 - Save carton and packaging materials for inspection purposes.
 - Contact your local dealer, or if purchased directly, the Prince Castle Customer Sales Department at 1-800-722-7853 to arrange for a replacement to be sent.
2. Verify that all parts have been received. A rack kit should be received with bin.
3. Remove all packaging and the white protective covering from the bin.
3. Insert the racks into the appropriate heater compartment.
4. Plug unit into an appropriate 120 Volt outlet (NEMA L5-15P).

NOTE: When installing this bin, it should be confirmed that the ambient temperatures at the mounting site do not exceed 110 F.

CONTROL PANEL IDENTIFICATION

The **DHB-DDA** Dedicated Holding Bin has two different modes of operation, the **Time Mode** and the **Temperature Mode**. The individual buttons on the control panel will have different functions dependant upon which mode the unit is in. The unit will be in the Temperature Mode when initially switched on.

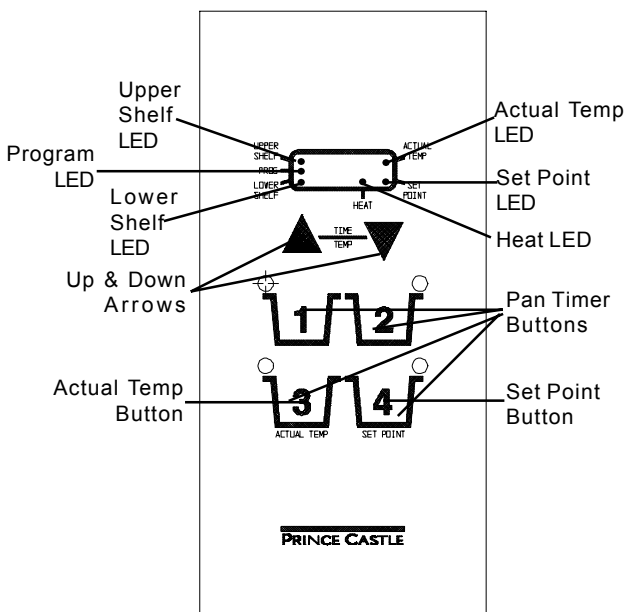

TEMPERATURE MODE FUNCTIONS

UPPER SHELF LED: When lit, indicates that the temperature displayed is for one of the upper shelf heaters, a **U** will appear in the display for the upper heater, a **L** for the lower heater.

LOWER SHELF LED: When lit, indicates that the temperature displayed is for one of the lower shelf heaters, a **U** will appear in the display for the upper heater, a **L** for the lower heater. **ACTUAL TEMP LED:** When lit, indicates that the actual temperature for the selected heater is displayed.

SET POINT LED: When lit, indicates that the Set Point Temperature for the selected heater is displayed.

PROG LED: When lit, indicates the controller is in the Program Mode.

HEAT LED: When lit, indicates that the selected heater is cycling on.

UP ARROW or DOWN ARROW: Pressing either button will allow the operator to select another heater assembly for display or programming purposes.

ACTUAL TEMP BUTTON: When pressed, the actual temperature for the selected heater will appear in the display.

SET POINT BUTTON: When pressed, the set point temperature for the selected heater will appear in the display.

SET POINT BUTTON and DOWN ARROW: When pressed simultaneously, will enter the program mode for changing the set point temperature for the selected heater assembly.

UP ARROW and DOWN ARROW: When pressed & held simultaneously, will switch controller from Temperature Mode to Time Mode or Time Mode to Temperature Mode.

OPERATION

1. Turn on power switch.
2. Allow heater assemblies to reach operating temperatures. The four heater assemblies are factory preset at 160 F.
3. Press and hold both the **UP ARROW** and **DOWN ARROW** to change the controller to the Time Mode. "----" will appear in the display.

4. Place a pan of product into the appropriate rack location.
5. Press the appropriate Pan Timer Button. The red LED for the Pan Timer Button will flash and the programmed holding time for that product will begin to countdown. **Note:** All four Pan Timer Buttons are preset for 30 minutes. The countdown time will be displayed in hours and minutes, until the time reaches 10 minutes. At that point, the display will change to minutes and seconds.
6. If more than one Pan Timer Button is activated, the active pan timer with the least amount of countdown time remaining will flash its LED indicator and the time remaining will appear in the display. The other active pan timers will have a solid red LED.
7. Remove product from the pan as necessary.
8. At the end of the countdown sequence, an audio alarm will sound and the display will flash "**END**". Press the Pan Timer Button with the flashing LED to cancel the audio alarm.
9. Remove that pan and discard the remaining product in it.

Note: Pan Timers can only be activated or deactivated when the controller is in the Time Mode.

To Cancel An Active Pan Timer When Pan Is Empty:

Press the Pan Timer Button three times. The Pan Timer LED will shut off and the display will revert back to show the Pan Timer with the least amount of countdown time remaining.

To View The Remaining Countdown Time For An Active Pan Timer:

The countdown time for the pan timer with the least amount of time remaining will appear in the display. To view the time remaining for another active pan timer, press the pan timer button. The remaining countdown time for that pan timer will appear in the display. When the button is released the display will revert back to the least remaining countdown time.

To View the Actual Or Set Point Temperature For A Selected Heater:

1. When in the Time Mode, press and hold both the **DOWN ARROW** and the **UP ARROW** for 5 seconds to change the controller to the Temperature Mode. The display will change to show the actual temperature for the currently selected heater.

2. Press either the **UP ARROW** or the **DOWN ARROW** to select the proper heater assembly.
3. Press either the **ACTUAL TEMP** or **SET POINT BUTTON** to display the desired temperature.
4. Press and hold both the **UP ARROW** and **DOWN ARROW** for 5 seconds to return to the Time Mode.

PROGRAMMING

To Program A Set Point Temperature Change:

1. Change the controller to the Temperature Mode, if it is not already in it, by pressing and holding both the **UP ARROW** and **DOWN ARROW** for 5 seconds. The display will change to show the currently selected heater assembly, indicated by the LED being lit next to either the **UPPER SHELF** or **LOWER SHELF** and a **U** or **L** appearing in the display.
2. Press either the **UP ARROW** or **DOWN ARROW** until the appropriate heater assembly is selected.
3. Press and hold the **SET POINT** Button and then the **DOWN ARROW** for 5 seconds. The **PROG LED** will light up, indicating the controller is in the program mode.
4. Press either the **UP ARROW** or **DOWN ARROW** until the desired temperature is reached.
5. Press the **SET POINT** button to store the change and return to the Temperature mode.
6. Follow the same steps to change any other Set Point Temperatures.

Note: Each heater assembly can be programmed to be off or from 150 F to 275 F.

To Program A Pan Timer Change:

NOTE: To program pan timer changes, the controller must be in the Timer Mode. If the controller is in the Temperature Mode, press and hold the **UP ARROW** and **DOWN ARROW** for 5 seconds. (Times can be programmed From "0" to 9:59 Hours.)

PAN TIMER #1

1. Press and hold **Pan Timer Button #1** and then the **UP ARROW** for approximately 6 seconds. The program LED will light up and the display will show the current countdown time for the channel.

2. Press either the **UP ARROW** or **DOWN ARROW** to adjust the time.
3. When the correct time is displayed, press **Pan Timer Button #1** to store the new time and return to the timer mode.

PAN TIMER #2

1. Press and hold **Pan Timer Button #2** and then the **DOWN ARROW** for approximately 6 seconds. The program LED will light up and the display will show the current countdown time for the channel.
2. Press either the **UP ARROW** or **DOWN ARROW** to adjust the time.
3. When the correct time is displayed, press **Pan Timer Button #2** to store the new time and return to the timer mode.

PAN TIMER #3

1. Press and hold **Pan Timer Button #3** and then the **UP ARROW** for approximately 6 seconds. The program LED will light up and the display will show the current countdown time for the channel.
2. Press either the **UP ARROW** or **DOWN ARROW** to adjust the time.
3. When the correct time is displayed, press **Pan Timer Button #3** to store the new time and return to the timer mode.

PAN TIMER #4

1. Press and hold **Pan Timer Button #4** and then the **DOWN ARROW** for approximately 6 seconds. The program LED will light up and the display will show the current countdown time for the channel.
2. Press either the **UP ARROW** or **DOWN ARROW** to adjust the time.
3. When the correct time is displayed, press **Pan Timer Button #4** to store the new time and return to the timer mode.

Calibration Mode

The calibration mode offers a method to compensate between what temperature the controller senses and the temperature that a independent surface probe reads. Calibration should be done on a monthly basis.

Note: Allow the heaters sufficient time to temperature stabilize before starting the Calibration Mode. The controller must be in the Temperature Mode to do heater calibrations.

1. Press the **UP ARROW** or the **DOWN ARROW** to select the heater assembly to be calibrated.
2. Take a surface temperature reading near the center of the heater assembly. **CAUTION:** The surface temperatures are **HOT**, caution must be used when taking temperature readings.
3. Press and hold the **ACTUAL TEMP** Button and the **UP ARROW** for 6 seconds. The program mode LED will light up and the actual temperature sensed by the controller will appear in the display.
4. Press the **UP ARROW** or **DOWN ARROW** to adjust the display temperature until it matches the surface probe temperature.
5. Press the **ACTUAL TEMP** Button to store the calibrated temperature and return to the Temperature Mode.

NOTE: To clear the offset value for a heater, press the **SET POINT** Button while in the calibration mode. The action will reset the offset value back to zero.

CLEANING

- 1) Turn off power switch.
- 2) Unplug power cord from receptacle.
- 3) Allow heaters to cool (approximately 15 minutes).
- 4) Wipe down with a damp cloth. **DO NOT USE AN ABRASIVE PAD, UNAPPROVED CLEANING SOLUTIONS, ICE OR WATER.**

CAUTION: This appliance is not water tight. Do not clean with a Water Jet/Jet Spray. Do not immerse in water.

TROUBLESHOOTING

The controller incorporates some diagnostic hardware and software to aid in troubleshooting problems. The display will flash the problem if detected when the heater in question is selected.

Problem	Cause	Solution
A. Display flashes "Opn" & "rEL"	Open relay. Circuit inoperable	Replace Power Circuit Board
B. Display flashes "SHr" & "rEL"	Shorted relay. Circuit inoperable. Open heater. Unplugged ribbon cable between Power and Main Circuit Boards.	Replace Power Circuit Board. Test heater resistance. 150.2 OHMS. Verify ribbon cable connection.
<p>C. Display shows "LLL"</p> <p>Display shows "LLL" for an extended period of time.</p> <p>Display shows "LLL" and then changes to "Opn" & "rel" and heater surface temperature is cool.</p> <p>Display shows "LLL" and then changes to "SHr" & "rEL" and heater surface temperature is cool.</p>	<p>Temperature is below 75° F (normal operation)</p> <p>Heater inoperable. Probe inoperable.</p> <p>Circuit inoperable. (see A).</p> <p>Circuit inoperable. (see B)</p>	<p>N/A</p> <p>Test heater resistance. 150.2 OHMS. Check for open thermocouple wires from probe. Replace heater/probe assembly.</p> <p>See A above.</p> <p>See B above.</p>
<p>D. Display shows "HHH" for an extended period of time and heater surface temperature is hot.</p> <p>Display shows "HHH" for an extended period of time and heater surface temperature is cool.</p>	<p>Temperature is above 400° F (abnormal operation)</p> <p>Probe is inoperable</p>	<p>Diagnostic circuit inoperable. Replace Power Circuit Board. See B above.</p> <p>Check for pinched thermocouple wires from probe. Replace heater/probe assembly.</p>

EXPLODED VIEW

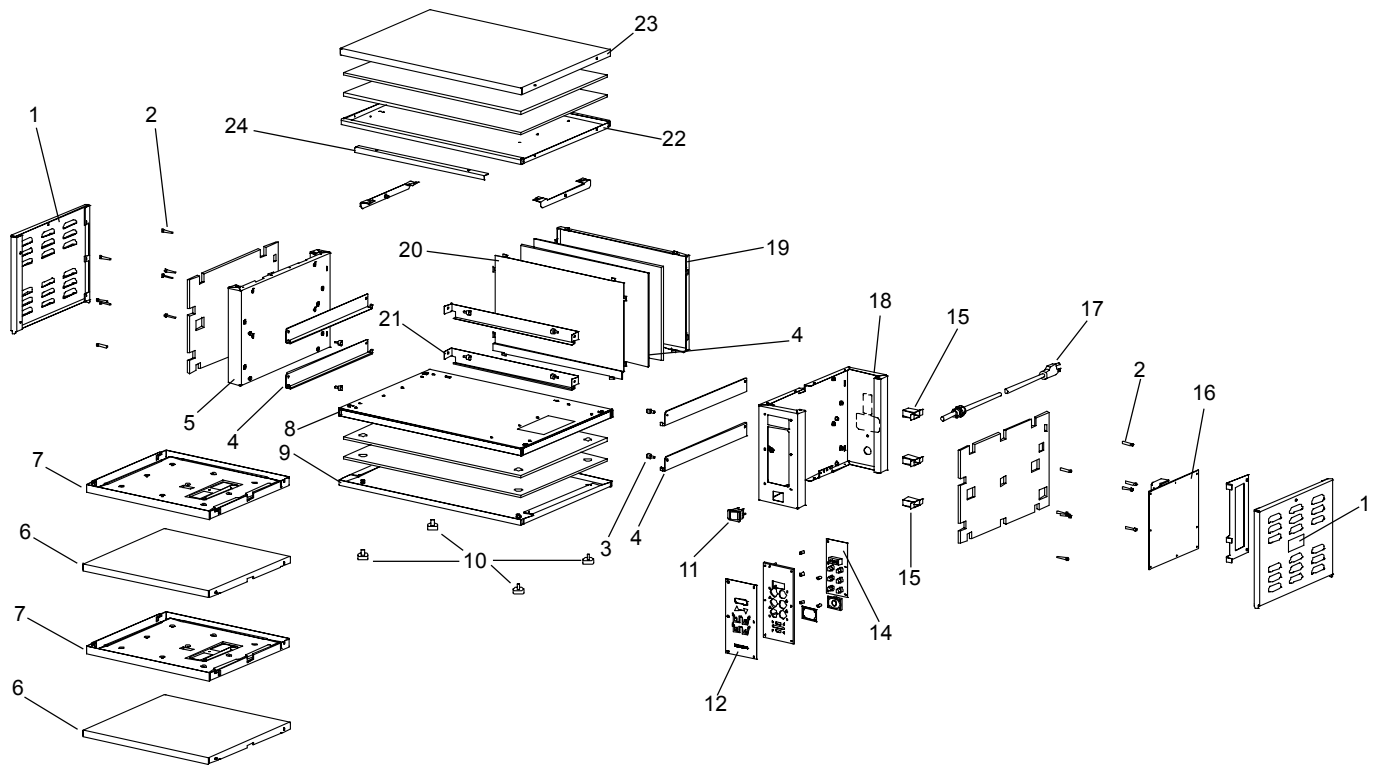

PARTS LIST

1	542-112	Cover, Side
2	76-719	Pin, Heater
3	542-114	Retainer, Shelf
4	542-113	Bracket, Shelf
5	542-108	Chassis, Left
6	542-059S	Lower Heater Assembly
7	542-121S	Upper Heater Assembly
8	542-072	Base
9	542-073	Cover, Bottom
10	197-232	Rubber Foot
11	78-166S	Power Switch
12	542-020S	Overlay with Bracket (542-082)
13	88-653S	Speaker Assembly
14	542-010S	Display P.C. Board
15	542-085	Wire Tunnel
16	542-011S	Main P.C. Board (120V)
17	72-322S	Power Cord
18	542-106	Chassis, Right
19	542-078	Panel, Outer Rear
20	542-077	Panel, Inner Rear
21	542-118	Bracket, Rear Shelf
22	542-074	Header
23	542-075	Cover, Top
24	542-097	Trim, Top Heater

WIRING DIAGRAM

