

# OPERATING INSTRUCTIONS

PRINCE CASTLE INC.   
A MEMBER OF

## Excalibur®



### Model No.424-G Dual Chamber Toaster

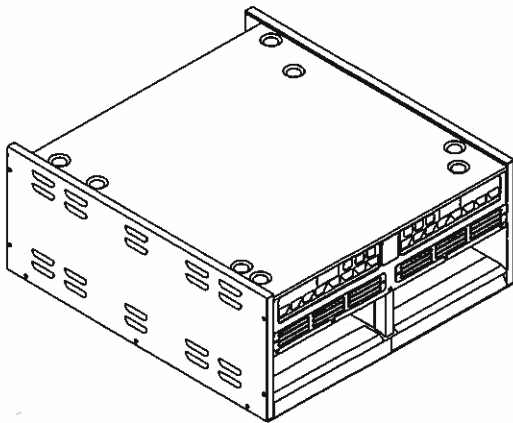

### SPECIFICATIONS

#### DIMENSIONS:

WIDTH: 21"

LENGTH: 23"

HEIGHT: 11"

#### ELECTRICAL:

208 VAC 60HZ 4500 Watts Single Phase

#### TABLE OF CONTENTS

#### PAGE

Installation .....	2
Operation .....	2
Programming .....	3
Cleaning .....	3
Troubleshooting .....	4
Parts List .....	5
Exploded View .....	6
Wiring Diagrams .....	7

### LIMITED WARRANTY

This toaster is warranted to be free from defects in material and/or workmanship for a period of (1) Year from date of original installation or (18) months from date of shipment from factory. Any part or component which proves to be faulty will be replaced or repaired without cost to the customer for parts or labor. (At the option of Prince Castle Inc.)

This warranty is subject to the following exceptions/conditions:

Any use of **Non-Genuine Prince Castle Parts** voids this warranty.

This toaster is **portable**; charges for on location service (e.g., trip charges, mileage) are only included in the first 30 days of this warranty.

All labor shall be performed during regular work hours. Overtime premium may be charged to the buyer.

Damage caused by carelessness, neglect, and/or abuse (e.g., using wrong current, dropping, tampering with or altering electrical components, or improper cleaning) voids this warranty.

All problems due to operation at voltages other than specified on toaster nameplates.

Equipment damaged in shipment, by fire, flood or an act of God.

This product must be serviced by a Prince Castle Authorized Service Center or a Prince Castle Factory Service Technician. Failure to do so can void this warranty.

PRINCE CASTLE INC.   
WORLDWIDE

355 East Kehoe Blvd. • Carol Stream, IL 60188  
Tel: (630) 462-8800 • Fax: (630) 462-1460  
Toll Free: 1-800-PCASTLE

# INSTALLATION

**IMPORTANT:** A SPECIAL PACKING FOAM IS PROVIDED BETWEEN THE HEATING ELEMENTS AND THE PROTECTIVE WIRE. BE SURE TO REMOVE THIS FOAM PRIOR TO OPERATING TOASTER.

1. Position the Bun Toaster in a well ventilated area.
2. Unwrap crumb tray and bun spatula. Install crumb tray on toaster by sliding it into the brackets located on both sides of the heating compartments.

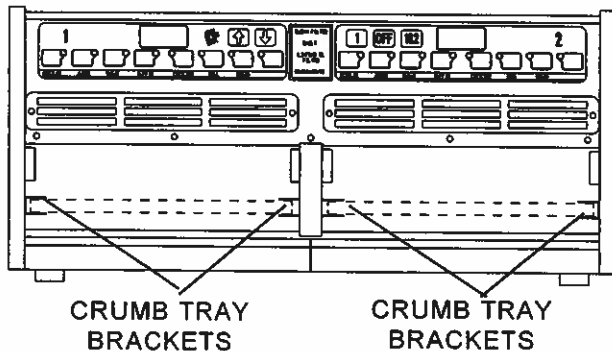

3. Wash, rinse, and sanitize spatula prior to use.  
**NOTE:** When using spatula to toast products, slide it in above the crumb tray. When not toasting, slide underneath the crumb tray.

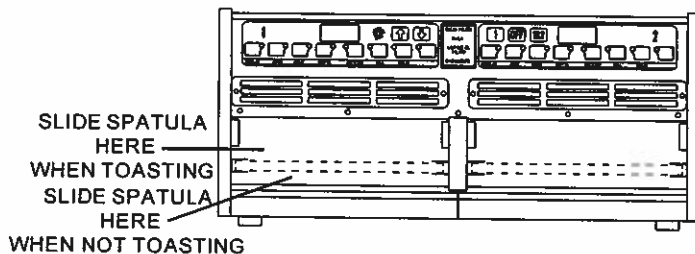

**IMPORTANT:** Clean air filters daily and DO NOT block air filter at FRONT of cabinet, as this may cause toaster to overheat and damage components voiding the warranty.

4. Insert the 3 pin Power Cord plug into a 208 VAC 60HZ 5850 Watts Single Phase circuit. Once inserted twist plug to the right, lock into position.

5. To Turn the Power "ON". Press 1 & 2 if you want to use both sides of the toaster. Press 1 if you want to use one side only. The left display will read CLN & the right display will read FLT. This stands for **clean filter** to remind you to keep your filters clean.



6. Toaster requires approximately 2 minutes warm up and the displays will read RDY indicating the toaster is ready for use.



# OPERATION

The following toasting times were pre - set at the factory prior to shipment. Adjustments may be necessary due to variable cut or moisture content of the product, see PROGRAMMING section if necessary.

**NOTE:** Display is in minutes and seconds.



PRODUCT	TIME
Regular	00:27
Jumbo	00:27
Wheat	00:30
Muffin	00:45
Crescent	00:20
Roll	01:00
Bread	00:00

1. Place product, cut side up, onto spatula.
2. Load spatula into the toasting chamber.
3. To start a toasting cycle press the button. The display will light up and begin counting down.

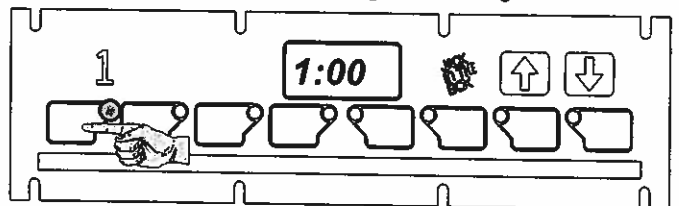

**Note:** To cancel an activated channel, press that channel once and it will stop counting down.

- When the countdown sequence has finished an audio alarm will sound and the display will read **END**. The audio alarm will automatically stop after 5 seconds or you can manually cancel by pressing the product button.

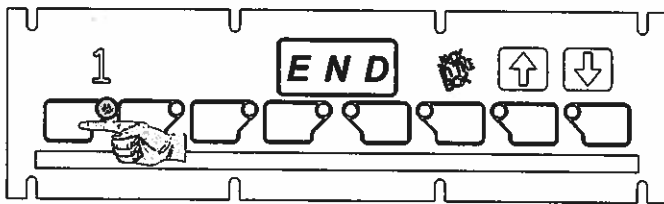

- When you have set the desired toast time press the **PRODUCT BUTTON** again. The display will go blank for a second, then it will display **888** and then **RDY**. To adjust the time on the other product buttons repeat steps 1-3.

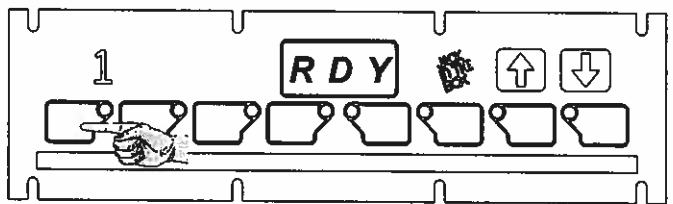

## PROGRAMMING

- Press and hold the **LOCK BOX** and the **PRODUCT BUTTON** that you want to change for 6 seconds, the display will read **P--D** and the **PRODUCT BUTTON LED** will light up.

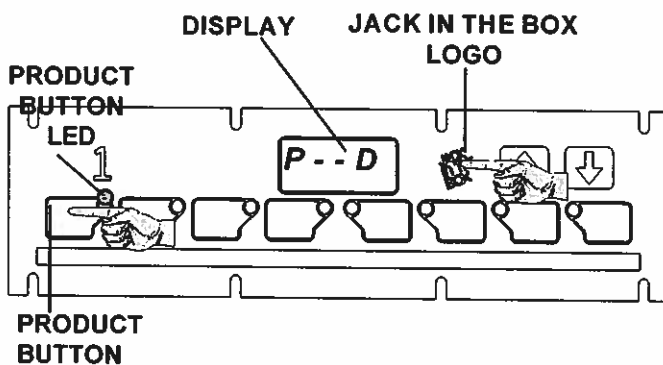

- The left digit will flash. Press the **UP** to change the flashing digit to a higher number. Press **DOWN** to change to a lower number.

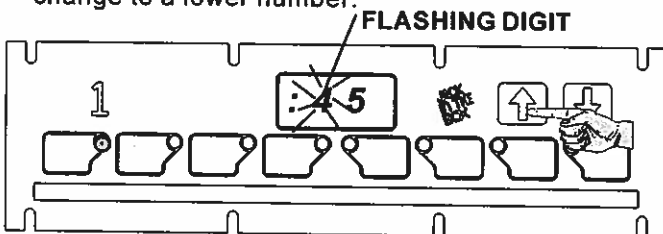

- Press the **LOCK BOX** to move to the next digit. Repeat step 2 to change the other digits.

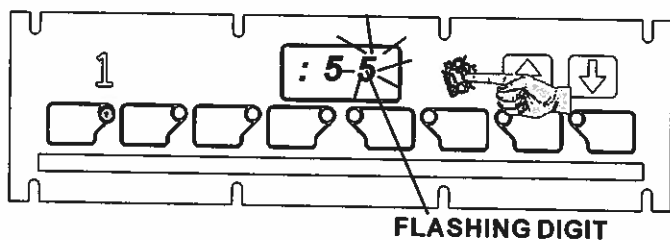

## VOLUME ADJUSTMENT

The audio alarm can be adjusted to two settings "HIGH" and "LOW".

- To choose the "HIGH" setting press & hold **LOCK BOX** **UP**
- To choose the "LOW" setting press & hold **LOCK BOX** **DOWN**

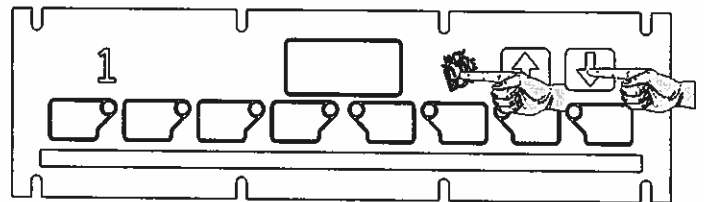

## CLEANING

- Before cleaning the toaster press the "OFF" button on the right display to turn the toaster off. **NOTE: After turning the power off the fans will continue to run for about (7) minutes to help cool down the heaters. Unplug from the outlet and allow 20 minutes to cool down.**

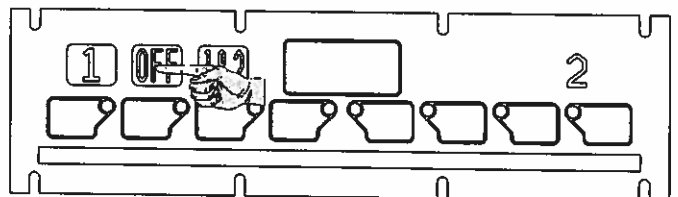

- Wipe toaster with a clean damp cloth. **DO NOT** use any chemical cleaners on the front overlays.

**IMPORTANT:** Do not get water on the **HEATERS**. This could cause serious electrical damage to the toaster.

**IMPORTANT:** Clean air filter daily by soaking them in warm soapy water, rinse and let air dry.

# TROUBLESHOOTING

## Diagnostic Error Codes



**OPN / PRB = Open Probe**



**Too / Hot = Control Box Too Hot**



**SHR / PRB = Shorted Probe**



**LLL = Low Heat**



**OPN / RLY = Open Relay**



**HHH = Toasting Chamber Too High**



**SHR / RLY = Shorted Relay**

**IF THERE IS A FAILURE ON THE RIGHT SIDE HEATER THE TOASTER CAN STILL BE OPERATED ON THE LEFT SIDE ONLY. IF THERE IS A FAILURE ON THE LEFT SIDE HEATER THE TOASTER CANNOT BE USED.**

PROBLEM	CAUSE	SOLUTION
1. Display reads SHR / REL OPN / REL SHR / PRB OPN / PRB	1. Shorted Relay. 2. Open Relay. 3. Shorted Probe. 4. Open Probe.	1. Turn toaster off and call your authorized Prince Castle Service Agent to arrange repair.
2. Display Reads HHH or Too Hot.	1. Dirty Air Filter. 2. Heater Temperature or control box temperature too high	1. Clean Air Filter. 2. Turn toaster off and call your authorized Prince Castle Service Agent to arrange repair.
3. Product too light or too dark	1. Toast Time Incorrect.	1. Adjust toast times .
4. Product button does not activate countdown sequence.	1. Inoperable operate switch.	1. Turn toaster off and call your authorized Prince Castle Service Agent to arrange repair.
5. Toaster will not turn on.	1. Unit Unplugged. 2. Circuit Breaker off. 3. Inoperable Power Switch. 4. Open Power Cord 5. Open Ribbon Cable	1. Plug Unit In. 2. Switch Circuit Breaker On. 3. Contact your Authorized Prince Castle Service Agent To Arrange Repair

Ribbon cable  
424-75\$

# PARTS LIST

ITEM NUMBER	PART NUMBER	DESCRIPTION
1	424-38	FACEPLATE
2	424-94S	LEFT SIDE OVERLAY PANEL
3	424-93S	RIGHT SIDE OVERLAY PANEL
4	86-074	SPACER
5	424-14S	LEFT SIDE DISPLAY P.C.BOARD
6	424-74S	SPEAKER
7	424-87S	HEATER
8	<del>65-035S</del> 058\$	RELAY
9	89-705S	FAN
10	307-76	TRANSFORMER
11	424-98	GASKET
12	424-101	GASKET RETAINERS
13	424-56S	PROBES
14	424-170	HIGH LIMIT SWITCHES
15	424-12S	MAIN P.C.BOARD
16	76-095	SCREW
17	72-190S	POWER CORD
18	66-034	STRAIN RELIEF
19	77-052	TERMINAL BLOCK
20	197-232	FEET
21	79-148	FLAT WASHER
22	<del>424-79</del> 454-073	SPATULA
23	424-6	CRUMB TRAY
24	424-13S	RIGHT SIDE DISPLAY P.C.BOARD
25	424-27	LEFT SIDE MENU STRIP
26	424-29	RIGHT SIDE MENU STRIP
27	73-015	HEX NUT
28	76-064	SCREW
29	79-031	LOCK WASHER
30	73-021	HEX NUT
31	424-41S	FILTERS (PACK OF 4)
32	79-002	WASHERS
33	89-924	STANDOFFS
34	424-121	EXHAUST PANEL
35	424-129	LEFT SIDE FILTER CARTRIDGE
36	424-130	RIGHT SIDE FILTER CARTRIDGE

